

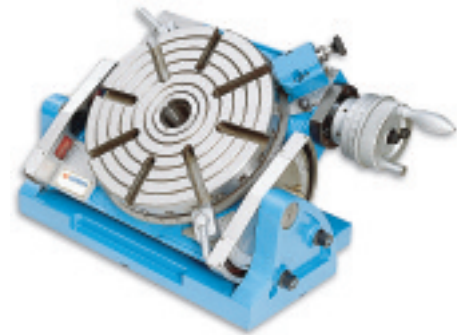

UNIVERSAL TILTING ROTARY TABLE

Model VU-100, VU-150, VU-300

- Tilting range 90° from horizontal to vertical position, 1 rotation of handle equals 3 degrees, 5 minutes tilting reading.
- 10 Second vernier scale
- Table Dial 1 minute graduations
- Fast degrees: Dividing notch pin & 24 holes in 15° around, insures rapid accurate spacing
- Minimum set-up time
- Rugged construction



UNIVERSAL TILTING ROTARY TABLES			
Size (inch)	4	6	12"
Size (mm)	100	150	300
Model No.	VU-100	VU-150	VU-300
Sowa Code No.	326-560	326-562	326-175
Price \$	883.00	1,011.00	4,145.60
Table Diameter	100mm	150mm	300mm
Table Height	117mm	140mm	185mm
Table Overall Height (Vertical)	177mm	216mm	370mm
Centre Hole			MT 5
Centre Height (Vertical)	80mm	90mm	208mm
Direct Indexing	24-div.	24-div.	24-div.
Gear Ratio	90:1	90:1	90:1
Weight (approx)	13.5 kg	21 kg	125 kg

PRECISION CROSS SLIDE TABLE

Model VCT-830

Model VCT-514

- A heavy, rugged slide in all kinds of positioning, milling, drilling, microscopic viewing and staging
- Adjustable bases for heavy loads, small jig boring, precision cut-off

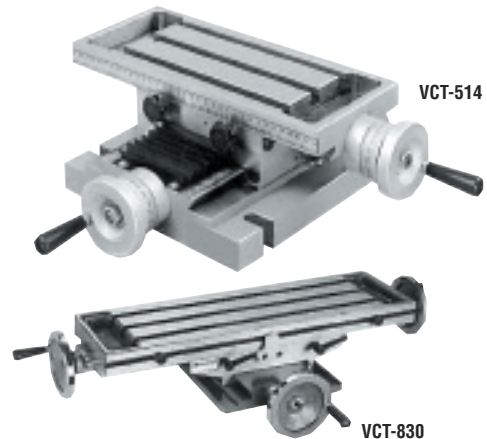

PRECISION CROSS SLIDE TABLE								
Model No.	Table (mm)	Height (mm)	Travel (mm)	Base (mm)	Dial Grad. (mm)	Net Weight (kg)	Code No.	Price \$
VCT-514	350 x 150	130	175 x 150	300 x 220	0.02	38	230-950	1,650.00
VCT-830	210 x 730	150	350 x 165	360 x 285	0.02	80	230-955	1,830.10

CROSS TABLE

Model VCT-512

Applied in general machines such as compounding machine, drilling machine, etc., or large objects of special shape which cannot be clamped by common vises.

- Lateral moving travel on surface: 11"
- Longitude moving travel on surface: 6"



CROSS TABLE								
Model No.	Table	Height	Travel	Base	Dial Grad.	Net Weight	Code No.	Price \$
VCT-512	300 x 140	115	200 x 125	225 x 200	0.03	16.6	230-965	597.20