



Alumi Mill Face Mill



- High rake angle ensures excellent finish and reduces cutting resistance
- For shouldering, curved surface, and slanted shouldering
- Buffed mirror finish of inserts allows outstanding chip control and prevents edge build up

Kits Also Available

➤ P. E180

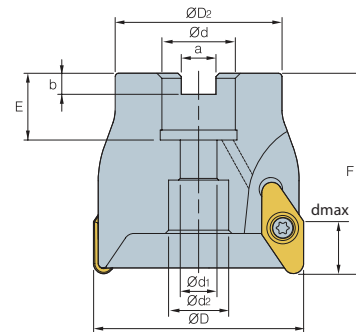

(inch)

Designation	Code No.	Price \$	ØD	Ød	ØD ₂	a	b	E	F	dmax	No. of Inserts
AMFM 4150R	147833	687.25	1.500	0.500	1.417	0.252	0.169	0.630	2.165	0.59	3
4200R	147424	698.15	2.000	0.750	1.772	0.321	0.220	0.787	2.165	0.59	3
4250R	147834	857.21	2.500	0.750	1.970	0.321	0.220	0.787	2.362	0.59	4
4300R	147470	901.91	3.000	1.000	2.205	0.384	0.248	0.866	2.362	0.59	4
4400R	147471	1,005.18	4.000	1.250	2.874	0.510	0.319	1.260	2.362	0.59	5

Inserts / Parts

Designation		Available Insert	Screw		Wrench	
AMFM	4150 4200 - 4400	VCKT 43.57.5N-MA	*FTNC04509 146752	\$ 8.72	FTNC04511 146424	\$ 8.76
		➤ P. E104	* For 4150R			

Recommended Cutting Condition

Workpiece	Cutting Condition		Grade
	V(sfm)	f(ip)	
P			
M			
K	Aluminum 750~2000	0.002~0.010	Uncoated (KTM10U)