

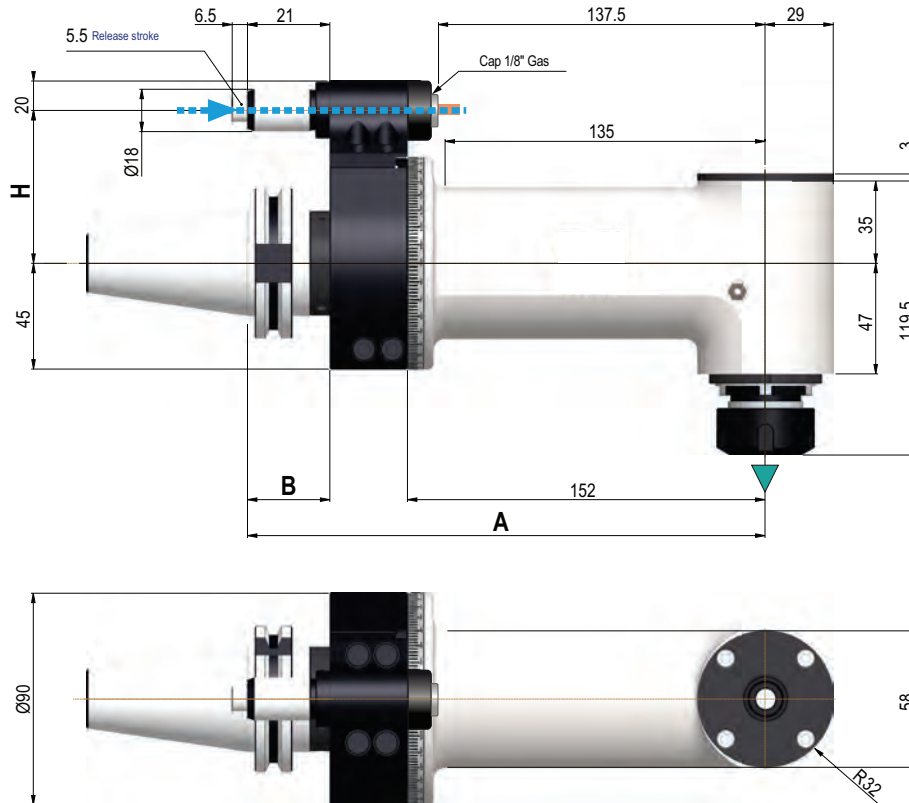

ANGLE HEADS

ATC Series

GFX16L



GFX16L ER25 Long Fixed 90° Right Angle Heads

Direction of rotation is the same as the machine spindle



Taper	Model	Collet System	A (mm)	B (mm)	H (mm)	End Mill & Drill Cap. (mm)	Tap Size Capacity	Max RPM	Weight (Kg.)	Code No.	Price \$
CAT40	GFX16L	ER25	220	35	65	16	M12	8,000	6.7	381400S	8,226.96
CAT50	GFX16L	ER25	220	35	80	16	M12	8,000	6.7	381402S	8,226.96
BT40	GFX16L	ER25	220	35	65	16	M12	8,000	6.7	381404S	8,226.96
BT50	GFX16L	ER25	226	41	80	16	M12	8,000	6.7	381406S	8,226.96
HSK63	GFX16L	ER25	227	42	65	16	M12	8,000	6.7	381408S	8,595.23
HSK100	GFX16L	ER25	230	45	80	16	M12	8,000	6.7	381410S	8,672.96

Other tapers available, please inquire.

* For Haas machines please contact Customer Service

Technical Data		GFX16L
Ratio		1:1
RPM Max		8,000
Max axial load	N	510
Torque	Nm	24
Weight	Kg.	6.7
Collet	mm	ER25 2mm-16mm

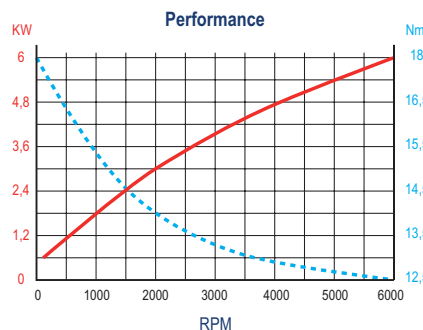

Standard Features & Equipment Included:

- Internal coolant from positioning pin
- Internal air pressure
- Retaining block
- Wrenches
- Grease tube
- Instruction book and Inspection report

