

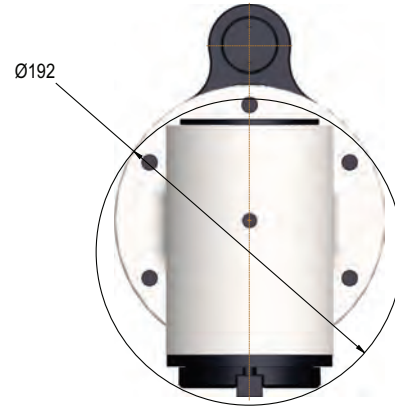

ANGLE HEADS

ATC Series

GFXS40

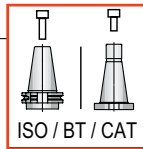
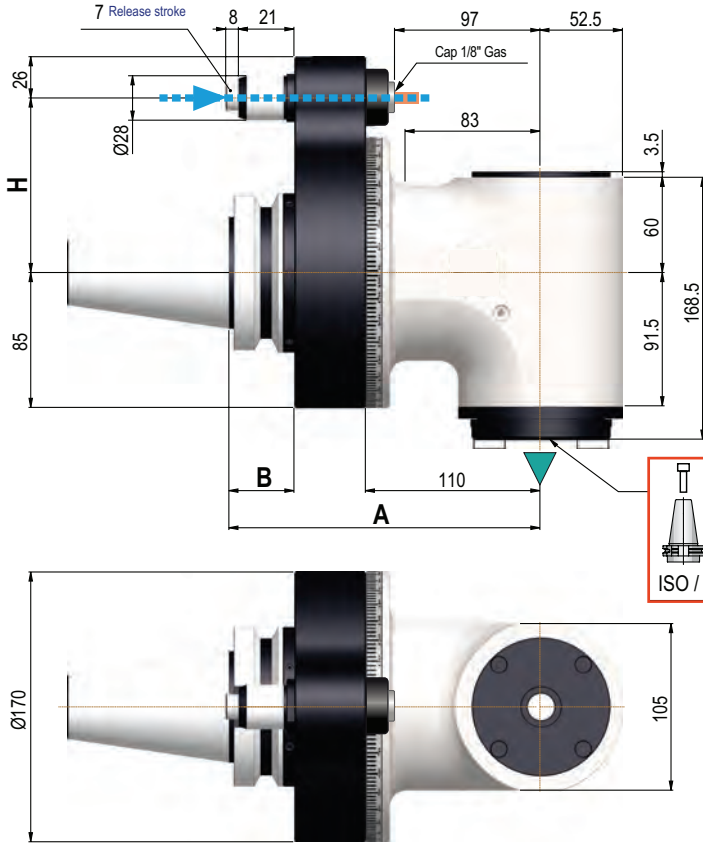

Note: Accepts CAT40, BT40, SK40 and NMTB 40 Taper Tooling

GFX S40 Fixed 90° Right Angle Heads

Direction of rotation is the same as the machine spindle



Taper	Model	A (mm)	B (mm)	H (mm)	End Mill & Drill Cap. (mm)	Tap Size Capacity	Max RPM	Weight (Kg.)	Code No.	Price \$
CAT50	GFX S40	190	35	110	26	M20	4,000	22	381121S	8,414.94
BT50	GFX S40	196	41	110	26	M20	4,000	22	381123S	10,939.42
HSK100	GFX S40	200	45	110	26	M20	4,000	22	381125S	11,610.17

Other tapers available, please inquire.
* For Haas machines please contact Customer Service

Technical Data		GFX S40
Ratio		1:1
RPM Max		4,000
Max axial load	N	1800
Torque	Nm	140
Weight	Kg.	22
Drill / Tap	mm	26mm/M20

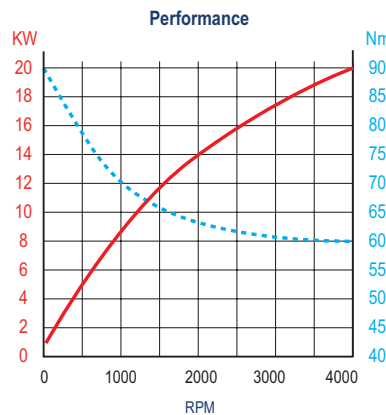

Standard Features & Equipment Included:

- Internal coolant from positioning pin
- Internal air pressure
- Retaining block
- Wrenches
- Grease tube
- Instruction book and Inspection report

