

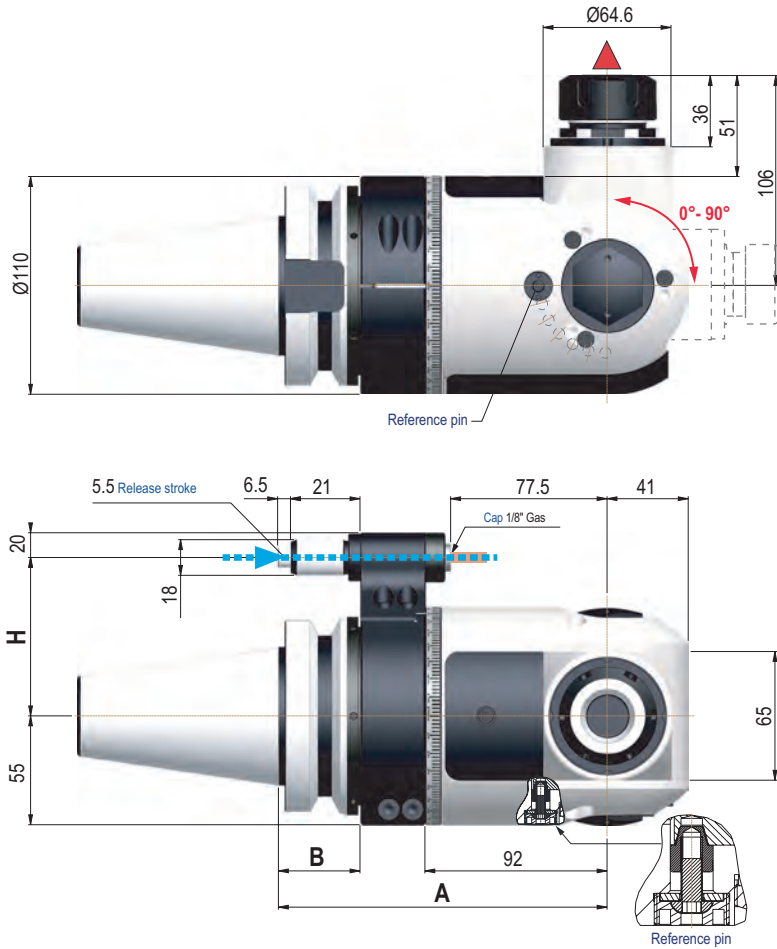

ANGLE HEADS

ATC Series

GPV20



GPV20 ER32 Pivoting Angle Heads

▼ Direction of rotation is opposite to the machine spindle



Taper	Model	Collet System	A (mm)	B (mm)	H (mm)	End Mill & Drill Cap. (mm)	Tap Size Capacity	Max RPM	Weight (Kg.)	Code No.	Price \$
CAT50	GPV20	ER32	160	35	80	20	M16	4,000	13	381150S	8,670.21
BT50	GPV20	ER32	166	41	80	20	M16	4,000	13	381154S	8,670.21
HSK100	GPV20	ER32	170	45	80	20	M16	4,000	13	381158S	9,133.29

Other tapers available, please inquire.

* For Haas machines please contact Customer Service

Technical Data		GPV20
Ratio		1:1
RPM Max		4,000
Max axial load	N	715
Torque	Nm	32
Weight	Kg.	13
Collet	mm	ER32 3mm-20mm

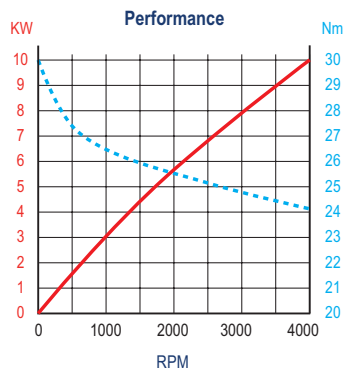

Standard Features & Equipment Included:

- Internal coolant from positioning pin
- Internal air pressure
- Retaining block
- Wrenches
- Grease tube
- Instruction book and Inspection report

