



Turret Type Quick Change Tool Post

Production of a lathe machine, even of high capacity, is conditioned to the speed and time required for changing tools. Fast tool changing and simplicity increase machine production. Our turrets are designed and constructed to achieve these essential requirements.

Our Turrets offer these advantages:

- 1 - No chatter or vibrations
- 2 - Save long set-up work for centering tool to centre of rotation axle
- 3 - No tool breakages, caused by poor or irregular setting of the tool on the shims

Price of Set Includes:

- 3 Tool-holders of flat section
- 1 Tool-holder with V-seat for round tools
- 2 Standard spanners

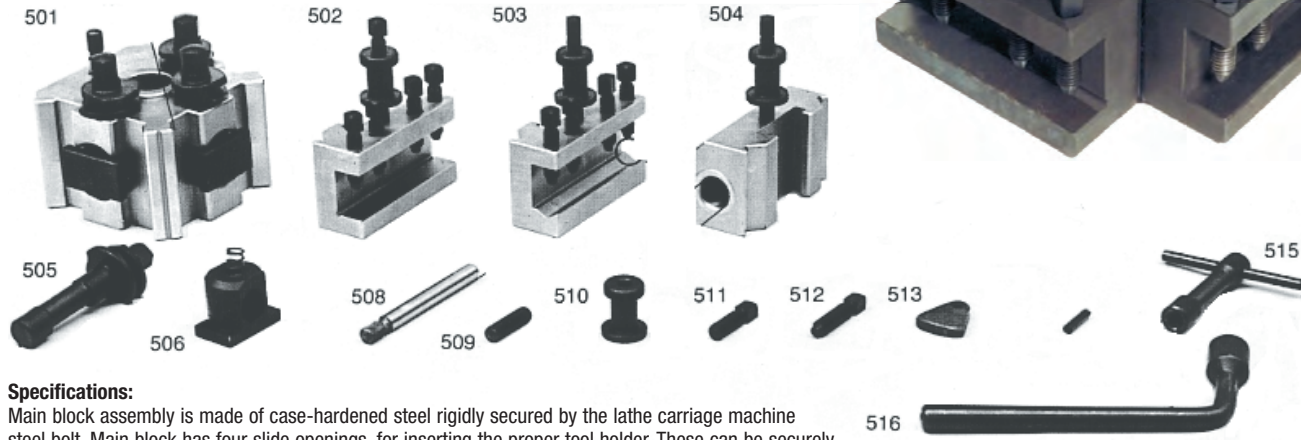
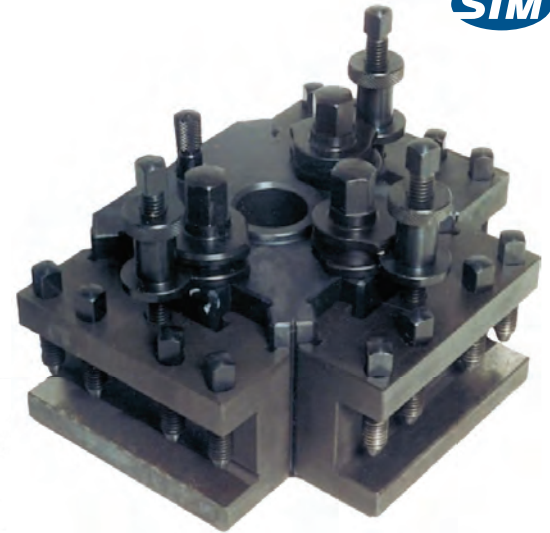

Specifications:

Main block assembly is made of case-hardened steel rigidly secured by the lathe carriage machine steel bolt. Main block has four side openings, for inserting the proper tool holder. These can be securely fastened by a simple and safe eccentric device, which also adjusts individual tool holder height. Tool shank is held securely by four hardened screws.

Quick Change Tool Posts & Holders



Size	Dimensions For Lathes with Swing (in.)	Max Height of Turret Body (in.)	Max. Square and Rect. Tools (in.)	Diameter Round Tool (in.)	Taper Shank	Max Adjust. Tool Holder (in.)	Sets Code No.	Price \$
M	7 - 10	2-3/4 x 2-3/4 x 1-3/4	5/8	1/2	1	1/2	385105	1,181.25
A	10 - 14	3-7/8 x 3-7/8 x 2-3/8	3/4	5/8	2	9/16	385110	1,268.92
B	14 - 18	4-5 x 5 x 3-3/8	1-1/8	13/16	3	15/16	385115	1,631.37
C	18 - 24	5-5/8 x 5-5/8 x 3-3/4	1-1/4	15/16	4	1	385120	2,084.86
D	over	6-7/8 x 6-7/8 x 4-3/4	1-1/2	1-1/4	4	1-1/2	385125	5,267.54

Fig.	Size Description	M Code No.	Price \$	A Code No.	Price \$	B Code No.	Price \$	C Code No.	Price \$	D Code No.	Price \$
STANDARD HOLDERS											
502	Flat tool holder	385205	116.34	385210	129.41	385215	169.67	385220	219.17	385225	790.53
503	V tool holder			385310	138.43	385315	192.57	385320	230.60		

Fig.	Size Description	M Code No.	Price \$	A Code No.	Price \$	B Code No.	Price \$	C Code No.	Price \$	D Code No.	Price \$
501	Master blocks					386103	1,111.01	386104	1,407.08	386105	2,853.28
505	Eccentric clamp pivot	386111	70.86	386112	85.80	386113	116.42	386114	123.29		
506	Clamping block			386122	68.79	386123	87.68	386124	101.25		
508	Dowel pin							386144	63.85	386145	111.24
509	Tool holder height adjusting screw			386152	3.27	386153	7.26	386154	7.26	386155	12.52
510	Bobbin for height adjusting screw	386161	20.79	386162	23.63	386163	28.46	386164	34.69	386165	60.21
511	Set screw for tool holder height adjust.			386172	3.93	386173	6.15	386174	6.15	386175	8.17
512	Set screw/tool holder	386181	4.61	386182	3.82	386183	6.75	386184	6.75	386185	10.08
513	Drift for drill holder			386192	34.69	386193	42.72	386194	42.72	386195	75.18
515	T-key for set screws			386212	50.17	386213	59.12	386214	73.68	386215	128.51
516	Hex. wrench for tool			386222	47.31	386223	50.17	386224	82.61	386225	143.85