

# Workholding, Clamping & Fixturing

## Soft Top Jaws — Metric Tongue & Groove

- For SMW/Autoblok, Berg, Forkardt, Rohm, Schunk

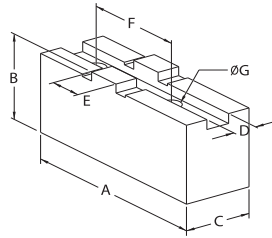

Model No.	Chuck Dia.	A (mm)	B (mm)	C (mm)	D (mm)	E (mm)	F (mm)	G (mm)	Weight kg.	Code No.	Individual Price \$
232200/F	160	85	40	20	8	18	32	9	0.38	491095	56.78
232201/F	200	105	50	25	10	20	40	9	0.62	491102	62.54
232202/F	250	125	50	30	12	20	40	13	1.12	491105	79.98
232203/F	315	145	60	35	12	26	54	13	1.93	491115	110.14
232204/F	400	180	80	50	18	30	60	17	4.56	491125	198.36

## Soft Top Jaws — American Tongue & Groove

- For Rohm Models ZG, ZS, ZGU, ZSU

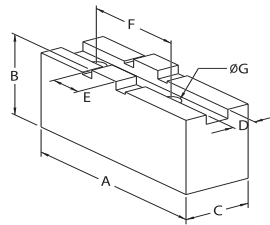

Model No.	Chuck Dia.	A (mm)	B (mm)	C (mm)	D (mm)	E (mm)	F (mm)	G (mm)	Weight kg.	Code No.	Individual Price \$
262200/R	100	53	30	25	7.96	9.49	24	7	0.24	491151	55.13
262201/R	125	62	40	25	7.96	12.67	32	9	0.36	491155	58.90
262202/R	160	74	45	30	7.96	12.67	38.1	9	0.61	491160	68.21
262203/R	200	87	45	30	7.96	12.67	44.45	9	0.76	491165	72.56
262204/R	250	103	50	35	12.72	19.02	53.95	13	1.1	491170	79.16
262205/R	315	120	60	40	12.72	19.02	63.50	13	1.87	491180	98.94
262205/R	315	140	60	40	12.72	19.02	63.50	13	2.2	491181	166.32
262206/R	350-400	140	70	50	12.72	19.02	76.20	17	3.0	491190	189.88
262207/R	450-800	160	80	50	12.72	19.02	76.20	21	3.5	491195	249.60

## Soft Jaw Forming Ring

The forming ring is used for cutting soft jaws by clamping and extending the through hole to increase the accuracy of clamping the workpiece.

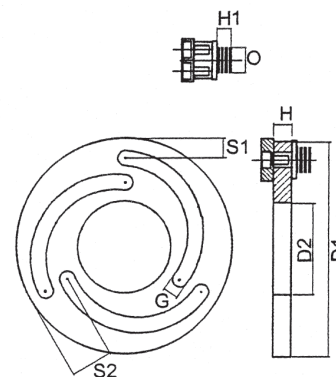

Model No.	For Chuck Dia.	H (mm)	D1 (mm)	D2 (mm)	S1 (mm)	S2 (mm)	G (mm)	H1 (mm)	O (mm)	Weight kg.	Code No.	Price \$
VFR-05	5"	12	140	60	12	28	10	9	13.5	1	326250	511.72
VFR-06	6"	12	168	80	12	32	10	9	16.5	1.5	326255	716.79
VFR-08	8"	12	218	115	17	36	10	9	18.5	2.4	326260	825.17
VFR-10	10"	12	258	150	15	40	10	9	18.5	3.2	326265	869.00
VFR-12	12"	15	316	118	21	50	10	9	21.5	5	326270	1,303.14