

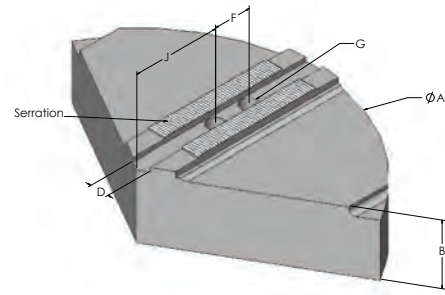

Pie Jaws 1.5mm x 60° Serrations

- Made with 6061 billet aluminum



Chuck Dia.	Aluminum Model No.	A Diameter	B Height	D Slot	F Hole Spacing	G Bolt Size	J Dim	Weight lbs.	Set of 3 Code No.	Set of 3 Price \$
6	KTT6P	6	2	0.472	0.787	10mm	1-21/32	5.7	658236	168.29
6	KTT6P1	6	4	0.472	0.787	10mm	1-21/32	10.8	658238	280.49
6	KTT8-6P	8	2	0.472	0.787	10mm	1-21/32	10.2	658240	224.39
8	KTT8P	8	2	0.551	0.984	12mm	2"	10.2	658242	224.39
8	KTT8P1	8	4	0.551	0.984	12mm	2"	19.8	658244	364.63
8	KTT10-8P	10	2	0.551	0.984	12mm	2"	16.2	658246	364.63
8	KTT12-8P	12	2	0.551	0.984	12mm	2"	23.4	658248	476.83
10	KTT10P	10	2	0.630	1.181	12mm	2-1/2	16.2	658250	364.63
10	KTT10P1	10	4	0.630	1.181	12mm	2-1/2	31.5	658252	532.92
10	KTT12-10P	12	2	0.630	1.181	12mm	2-1/2	23.4	658254	476.83
10	KTT15-10P	15	3	0.630	1.181	12mm	2-1/2	53.7	658256	1,178.04
12	KTT12P	12	2	0.709	1.181	14mm	3-1/2	23.4	658258	476.83
12	KTT12P1	12	4	0.709	1.181	14mm	3-1/2	45.3	658260	757.31
12	KTT15-12P	15	3	0.709	1.181	14mm	3-1/2	53.7	658262	1,178.04
12	KTTB212P	12	2	0.827	1.181	14mm	3-1/2	23.4	658264	476.83
12	KTTB212P1	12	4	0.827	1.181	14mm	3-1/2	45.3	658266	757.31
15	KTT15P	15	3	0.866	1.693	20mm	4-5/16	36.6	658268	1,178.04
15	KTT15P1	15	4	0.866	1.693	20mm	4-5/16	53.7	658270	1,458.52

Pie Jaws American Standard Tongue & Groove

- Made with 6061 billet aluminum

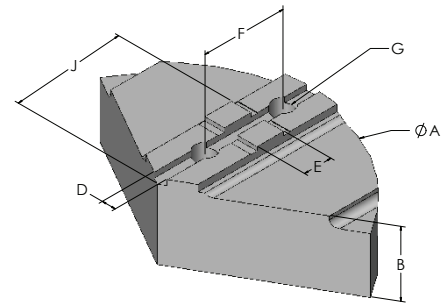

Chuck Dia.	Aluminum Model No.	A Dia.	B Height	D Slot	E Tongue	F Hole Spacing	G Bolt Size	J Dim.	Weight lbs.	Set of 3 Code No.	Set of 3 Price \$
6	TG6MDP	6	2	0.313	0.500	1.500	3/8	2"	5.7	658272	185.12
6	TG6MDP1	6	4	0.313	0.500	1.500	3/8	2"	10.8	658274	308.54
6	TG8-6MDP	8	2	0.313	0.500	1.500	3/8	2"	10.2	658276	252.43
8	TG8MDP	8	2	0.313	0.500	1.750	3/8	2-3/4	10.2	658278	252.43
8	TG8MDP1	8	4	0.313	0.500	1.750	3/8	2-3/4	19.8	658280	392.68
8	TG10-8MDP	10	2	0.313	0.500	1.750	3/8	2-3/4	16.2	658282	392.68
10	TG10MDP	10	2	0.500	0.750	2.125	1/2	3-1/2	16.2	658284	392.68
10	TG10MDP1	10	4	0.500	0.750	2.125	1/2	3-1/2	31.5	658286	560.97
10	TG12-10MDP	12	2	0.500	0.750	2.125	1/2	3-1/2	23.4	658288	504.88
10	TG15-10MDP	15	3	0.500	0.750	2.125	1/2	3-1/2	45.3	658290	1,206.09
12	TG12MDP	12	2	0.500	0.750	2.500	1/2	4-1/4	23.4	658292	504.88
12	TG12MDP1	12	4	0.500	0.750	2.500	1/2	4-1/4	45.3	658294	785.35
12	TG15-12MDP	15	3	0.500	0.750	2.500	1/2	4-1/4	53.7	658296	1,206.09
15	TG15MDP	15	3	0.500	0.750	3.000	5/8	5-1/4	53.7	658298	1,206.09
15	TG15MDP1	15	4	0.500	0.750	3.000	5/8	5-1/4	70.8	658300	1,486.57
15	TG15HDP	15	3	0.500	0.750	3.000	3/4	5-1/4	53.7	658302	1,206.09
15	TGHDP1	15	4	0.500	0.750	3.000	3/4	5-1/4	70.8	658304	1,486.57

