

## BT30 Shrink Fit Holders With Coolant Ports

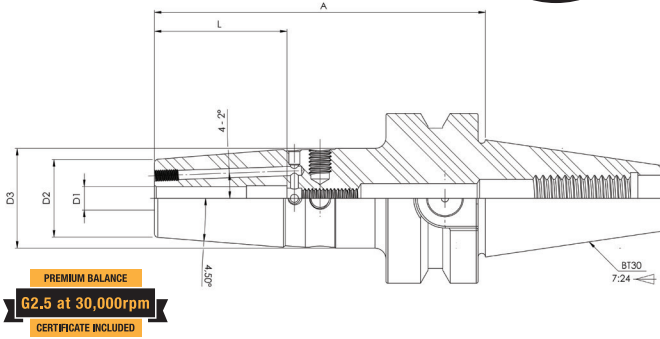

- Holders are balanceable with a balancing machine
- Balanced G2.5 at 30,000rpm
- 4 Coolant ports in the nose
- For maximum gripping power with exceptional concentricity
- TIR of  $\leq 0.0001'' / 0.003\text{mm}$  with tool shrunk in holder
- AT2 Taper Accuracy
- Tool is gripped 360° along the entire length of bore resulting in an evenly distributed clamping force
- Material: H13 Tool Steel
- The hot hardness (hot strength) of H13 resists thermal fatigue cracking which occurs as a result of cyclic heating and cooling cycles
- RFID chip hole



Taper	Hole Dia. (D1)	Gage Length (A)	D2	D3	L	Code No.	Price \$
<b>Inch</b>							
BT30	1/8"	3.15"	0.39"		0.35"	542414	<b>276.45</b>
BT30	3/16"	3.15"	0.39"		0.47"	542416	<b>276.45</b>
BT30	1/4"	3.15"	0.83"	1.06"	1.42"	542418	<b>202.35</b>
BT30	3/8"	3.15"	0.94"	1.26"	1.65"	542422	<b>202.35</b>
BT30	1/2"	3.15"	0.94"	1.26"	1.65"	542424	<b>202.35</b>
<b>Metric</b>							
BT30	4mm	80mm	10mm		12mm	542402	<b>276.45</b>

## Coolant Port Screws



Description	Code No.	Price \$
4pcs per Package	541801	<b>3.94</b>

## BT40 Shrink Fit Holders With Coolant Ports



- Holders are balanceable with a balancing machine
- Balanced G2.5 at 30,000rpm
- 4 Coolant ports in the nose
- For maximum gripping power with exceptional concentricity
- TIR of  $\leq 0.0001'' / 0.003\text{mm}$  with tool shrunk in holder
- AT2 Taper Accuracy
- Tool is gripped 360° along the entire length of bore resulting in an evenly distributed clamping force
- Material: H13 Tool Steel
- The hot hardness (hot strength) of H13 resists thermal fatigue cracking which occurs as a result of cyclic heating and cooling cycles
- RFID chip hole

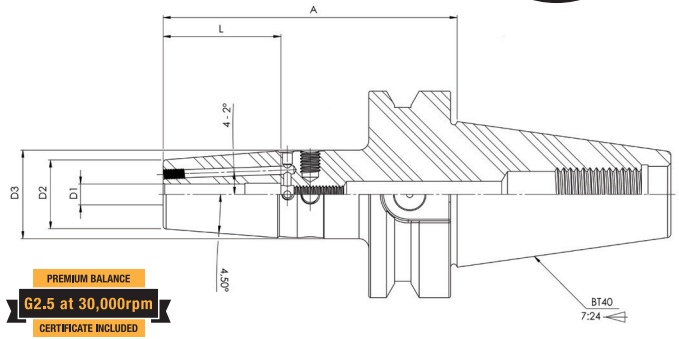

Taper	Hole Dia. (D1)	Gage Length (A)	D2	D3	L	Code No.	Price \$
<b>Inch</b>							
BT40	3/16"	3.54"	0.39"		0.47"	542466	<b>258.02</b>
BT40	1/4"	3.54"	0.83"	1.06"	1.42"	542468	<b>206.15</b>
BT40	1/4"	6.30"	0.83"	1.06"	1.42"	542470	<b>287.95</b>
BT40	3/8"	3.54"	0.94"	1.26"	1.65"	542476	<b>206.15</b>
BT40	1/2"	3.54"	1.06"	1.34"	1.65"	542480	<b>206.15</b>
BT40	1/2"	6.30"	1.06"	1.34"	1.65"	542482	<b>287.95</b>
BT40	3/4"	3.54"	1.30"	1.65"	2.05"	542488	<b>206.15</b>
BT40	3/4"	6.30"	1.30"	1.65"	2.05"	542490	<b>287.95</b>
BT40	1"	3.94"	1.73"	2.09"	2.28"	542492	<b>206.15</b>
BT40	1-1/4"	3.94"	1.73"	2.09"	2.28"	542496	<b>213.47</b>
<b>Metric</b>							
BT40	6mm	90mm	21mm	27mm	36mm	542432	<b>206.15</b>
BT40	8mm	90mm	21mm	27mm	36mm	542436	<b>206.15</b>

Prices in this catalogue are subject to change without notice. If there is a discrepancy between a product price listed in this catalogue and that listed on [www.sowatool.com](http://www.sowatool.com), the price on our website will take precedence.

Images are representational only and may not reflect actual product.