

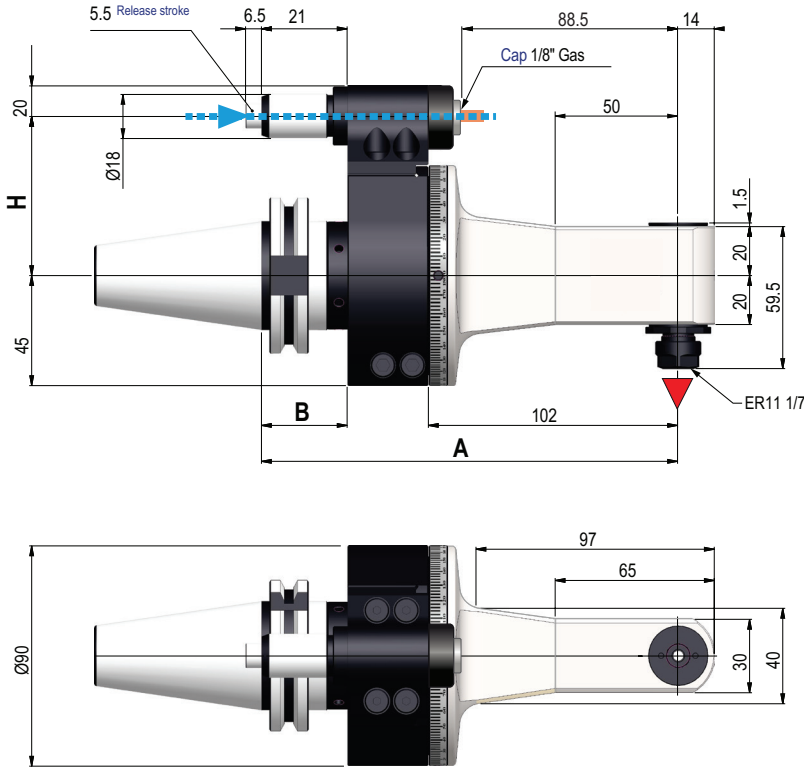

ANGLE HEADS

ATC Series

GFX07



GFX07 ER11 Fixed 90° Right Angle Heads

▼ Direction of rotation is opposite to the machine spindle



Taper	Model	Collet System	A (mm)	B (mm)	H (mm)	End Mill & Drill Cap. (mm)	Tap Size Capacity	Max RPM	Weight (Kg.)	Code No.	Price \$
CAT40	GFX07	ER11	170	35	65	7	M6	10,000	4	381002S	5,266.67
CAT50	GFX07	ER11	170	35	80	7	M6	10,000	4	381004S	5,266.63
BT40	GFX07	ER11	170	35	65	7	M6	10,000	4	381006S	5,115.03
BT50	GFX07	ER11	176	41	80	7	M6	10,000	4	381008S	5,115.03
HSK63	GFX07	ER11	177	42	65	7	M6	10,000	4	381010S	5,398.15
HSK100	GFX07	ER11	180	45	80	7	M6	10,000	4	381012S	5,454.62

Other tapers available, please inquire.
* For Haas machines please contact Customer Service

Technical Data		GFX 7
Ratio		1:1
RPM Max		10,000
Max axial load	N	120
Torque	Nm	5
Weight	Kg.	4
Collet	mm	ER11 1mm-7mm

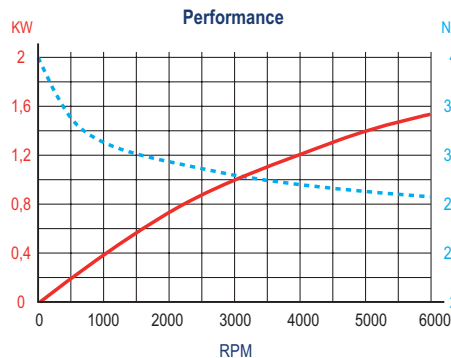

Standard Features & Equipment Included:

- Internal coolant from positioning pin
- Internal air pressure
- Retaining block
- Wrenches
- Grease tube
- Instruction book and Inspection report

