

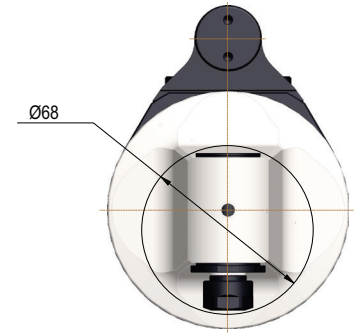

ANGLE HEADS

ATC Series

GFX07L

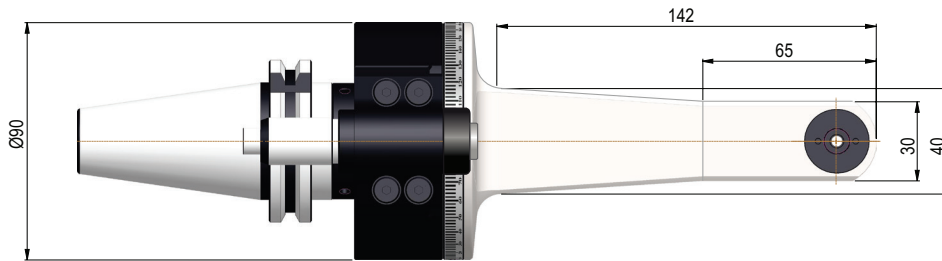
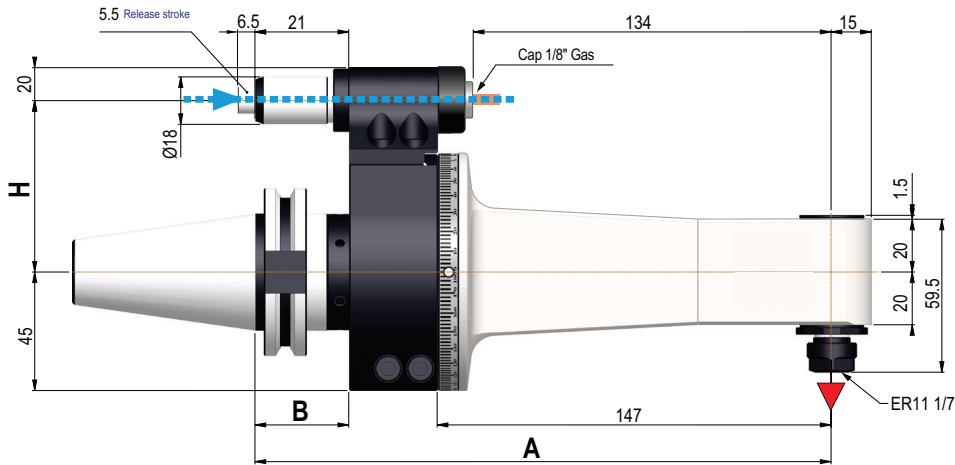

GFX07L ER11 Long Fixed 90° Right Angle Heads

▼ Direction of rotation is opposite to the machine spindle



Taper	Model	Collet System	A (mm)	B (mm)	H (mm)	End Mill & Drill Cap. (mm)	Tap Size Capacity	Max RPM	Weight (Kg.)	Code No.	Price \$
CAT40	GFX07L	ER11	215	35	65	7	M6	10,000	4.3	381302S	4,951.11
CAT50	GFX07L	ER11	215	35	80	7	M6	10,000	4.3	381304S	4,951.11
BT40	GFX07L	ER11	215	35	65	7	M6	10,000	4.3	381306S	4,951.11
BT50	GFX07L	ER11	221	41	80	7	M6	10,000	4.3	381308S	4,951.11
HSK63	GFX07L	ER11	222	42	65	7	M6	10,000	4.3	381310S	5,231.59
HSK100	GFX07L	ER11	225	45	80	7	M6	10,000	4.3	381312S	5,291.19

Other tapers available, please inquire.

* For Haas machines please contact Customer Service

Technical Data		GFX 7L
Ratio		1:1
RPM Max		10,000
Max axial load	N	120
Torque	Nm	5
Weight	Kg.	4.3
Collet	mm	ER11 1mm-7mm

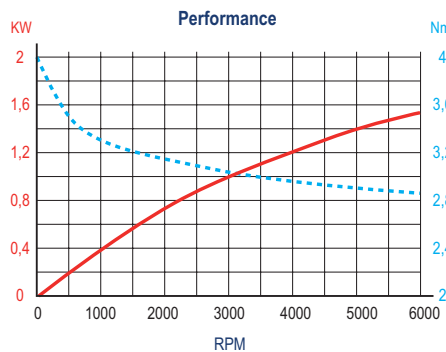

Standard Features & Equipment Included:

- Internal coolant from positioning pin
- Internal air pressure
- Retaining block
- Wrenches
- Grease tube
- Instruction book and Inspection report

