

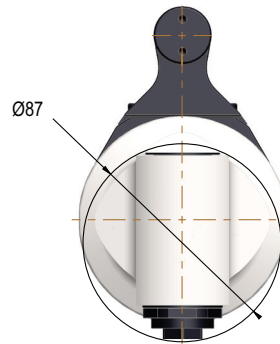

## ANGLE HEADS

# ATC Series

### GFX10

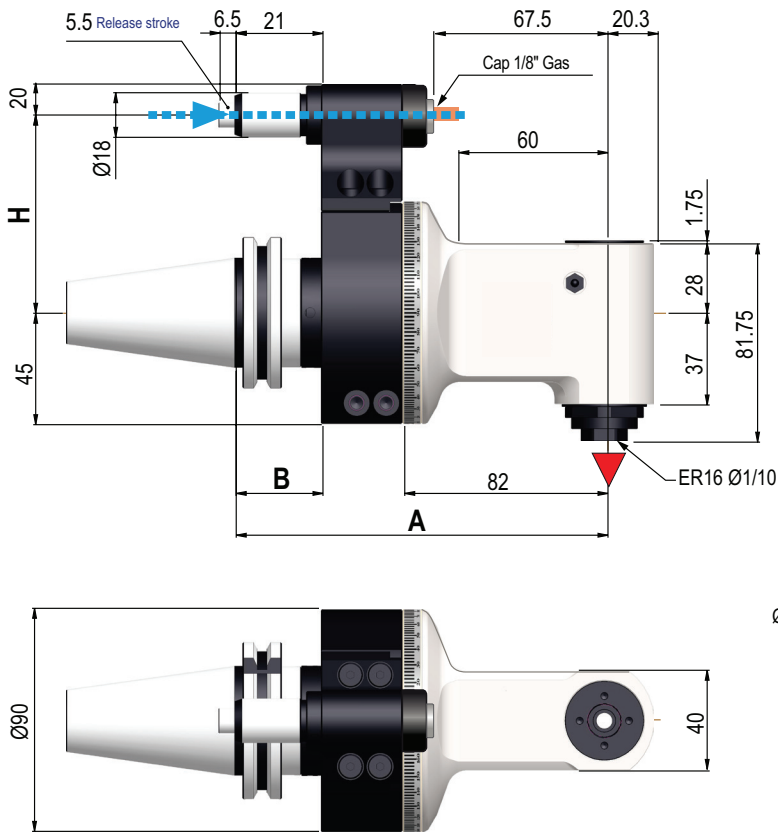

### GFX10 ER16 Fixed 90° Right Angle Heads

▼ Direction of rotation is opposite to the machine spindle



Taper	Model	Collet System	A (mm)	B (mm)	H (mm)	End Mill & Drill Cap. (mm)	Tap Size Capacity	Max RPM	Weight (Kg.)	Code No.	Price \$
CAT40	GFX10	ER16	150	35	65	10	M8	10,000	4.3	381020S	4,202.45
CAT50	GFX10	ER16	150	35	80	10	M8	10,000	4.3	381022S	4,202.45
BT40	GFX10	ER16	150	35	65	10	M8	10,000	4.3	381024S	4,202.45
BT50	GFX10	ER16	156	41	80	10	M8	10,000	4.3	381026S	4,202.45
HSK63	GFX10	ER16	157	42	65	10	M8	10,000	4.3	381028S	4,485.64
HSK100	GFX10	ER16	160	45	80	10	M8	10,000	4.3	381030S	4,546.31

Other tapers available, please inquire.  
\* For Haas machines please contact Customer Service

Technical Data		GFX10L
Ratio		1:1
RPM Max		10,000
Max axial load	N	250
Torque	Nm	10
Weight	Kg.	4.3
Collet	mm	ER16 1mm-10mm

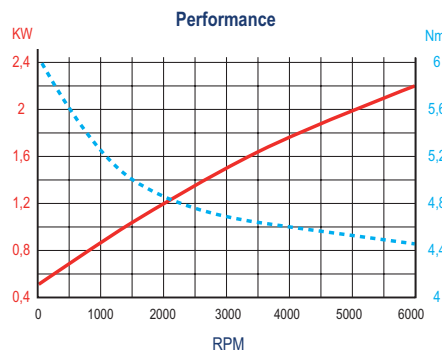

#### Standard Features & Equipment Included:

- Internal coolant from positioning pin
- Internal air pressure
- Retaining block
- Wrenches
- Grease tube
- Instruction book and Inspection report

