

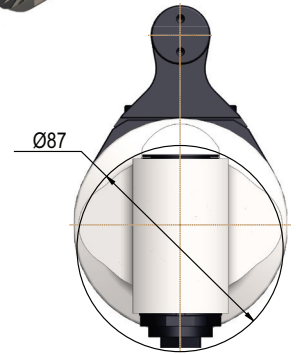

ANGLE HEADS

ATC Series

GFX10L

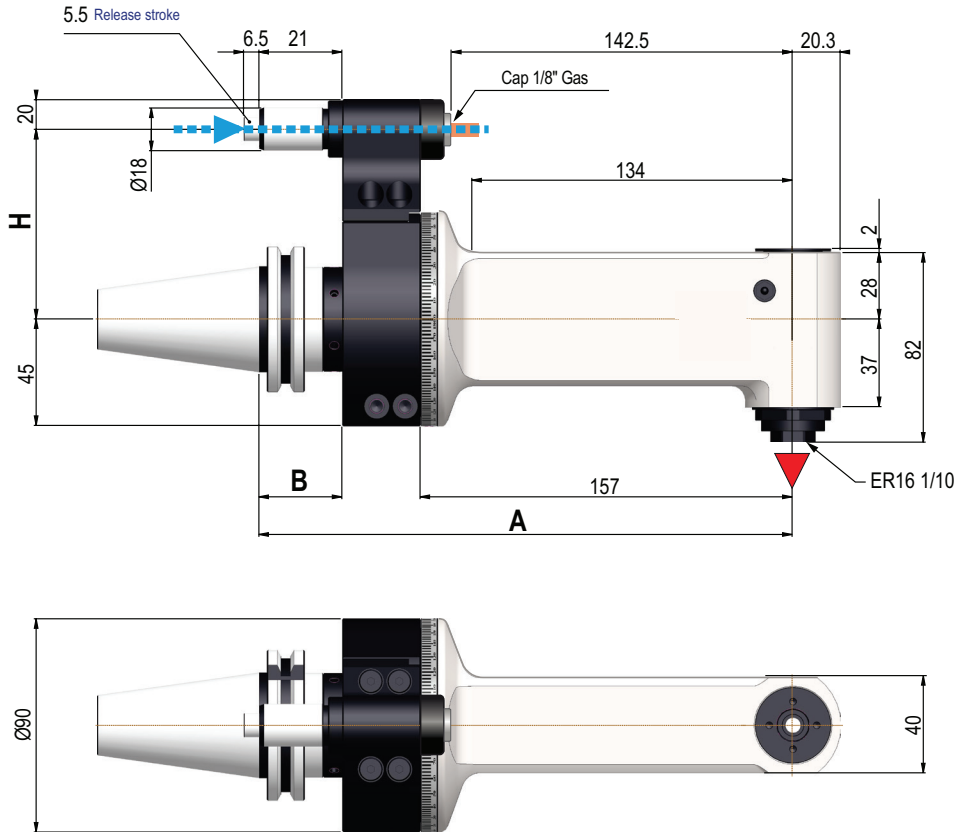

GFX10L ER 16 Long Fixed 90° Right Angle Heads

▼ Direction of rotation is opposite to the machine spindle



Taper	Model	Collet System	A (mm)	B (mm)	H (mm)	End Mill & Drill Cap. (mm)	Tap Size Capacity	Max RPM	Weight (Kg.)	Code No.	Price \$
CAT40	GFX10L	ER16	225	35	65	10	M8	10,000	5.2	381320S	5,026.22
CAT50	GFX10L	ER16	225	35	80	10	M8	10,000	5.2	381322S	5,026.22
BT40	GFX10L	ER16	225	35	65	10	M8	10,000	5.2	381324S	5,026.22
BT50	GFX10L	ER16	231	41	80	10	M8	10,000	5.2	381326S	5,026.22
HSK63	GFX10L	ER16	232	42	65	10	M8	10,000	5.2	381328S	5,298.23
HSK100	GFX10L	ER16	235	45	80	10	M8	10,000	5.2	381330S	5,353.67

Other tapers available, please inquire.

* For Haas machines please contact Customer Service

Technical Data		GFX10L
Ratio		1:1
RPM Max		10,000
Max axial load	N	250
Torque	Nm	10
Weight	Kg.	5.2
Collet	mm	ER16 1mm-10mm

Performance

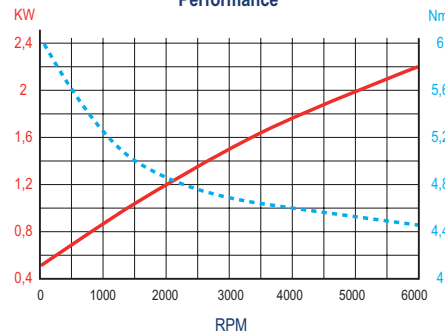

Standard Features & Equipment Included:

- Internal coolant from positioning pin
- Internal air pressure
- Retaining block
- Wrenches
- Grease tube
- Instruction book and Inspection report

