

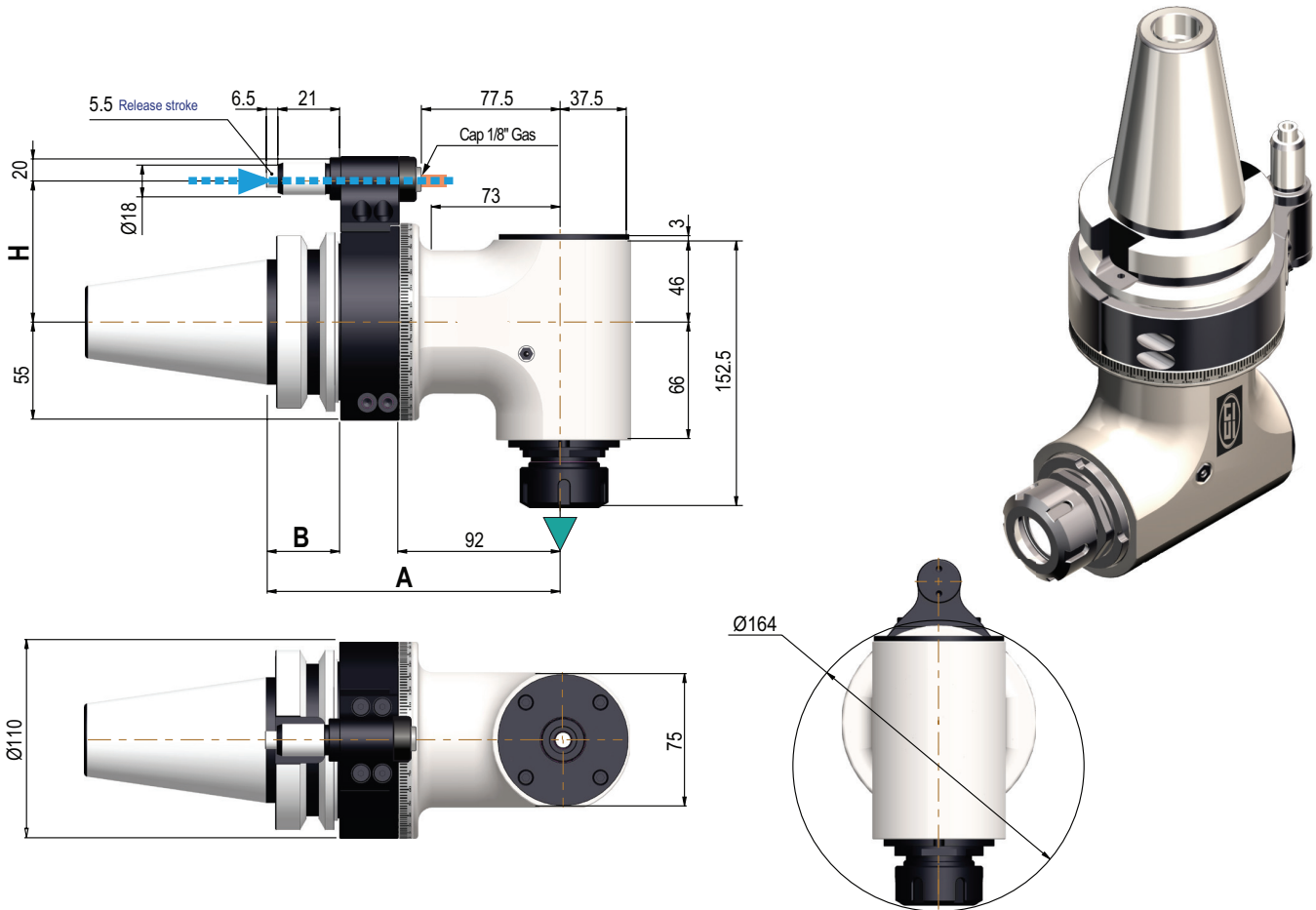

ANGLE HEADS

ATC Series

GFX20



GFX20 ER32 Fixed 90° Right Angle Head

▼ Direction of rotation is the same as the machine spindle



Taper	Model	Collet System	A (mm)	B (mm)	H (mm)	End Mill & Drill Cap. (mm)	Tap Size Capacity	Max RPM	Weight (Kg.)	Code No.	Price \$
CAT50	GFX20	ER32	160	35	80	20	M16	4,000	11	381148S	5,417.97

Other tapers available, please inquire.
* For Haas machines please contact Customer Service

Technical Data		GFX20
Ratio		1:1
RPM Max		4,000
Max axial load	N	1250
Torque	Nm	40
Weight	Kg.	11
Collet	mm	ER32 2.5mm-20mm

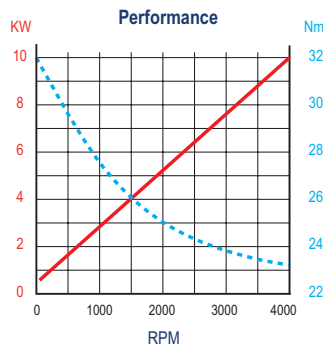

Standard Features & Equipment Included:

- Internal coolant from positioning pin
- Internal air pressure
- Retaining block
- Wrenches
- Grease tube
- Instruction book and Inspection report

