

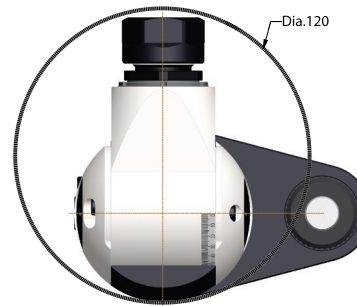

# ANGLE HEADS

# ATC Series

## GPV13

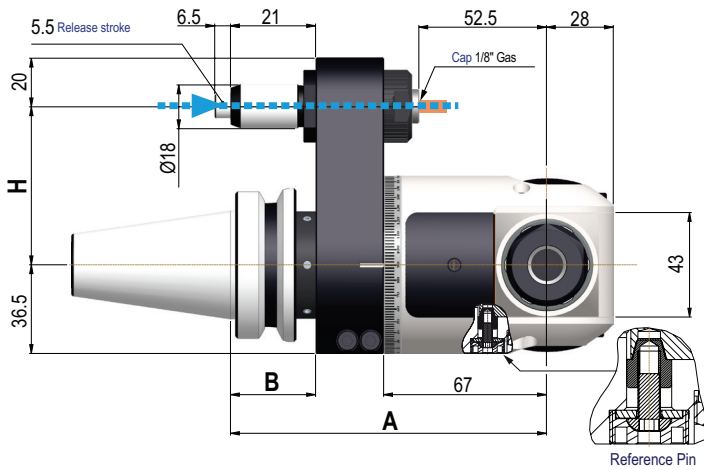
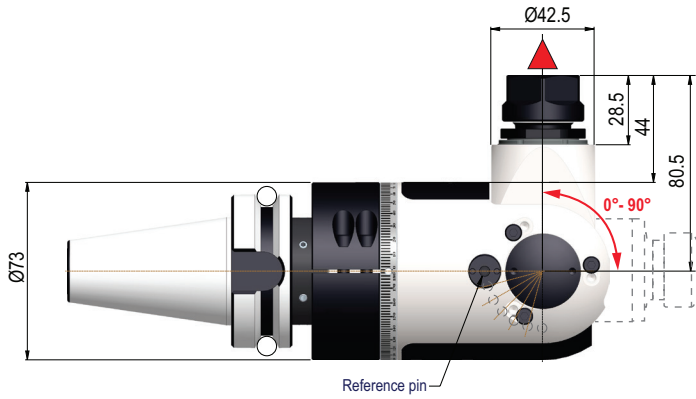

### GPV13 ER 20 Pivoting Angle Heads

▼ Direction of rotation is opposite to the machine spindle



Taper	Model	Collet System	A (mm)	B (mm)	H (mm)	End Mill & Drill Cap. (mm)	Tap Size Capacity	Max RPM	Weight (Kg.)	Code No.	Price \$
CAT40	GPV13	ER20	130	35	65	13	M10	4,000	4.2	381198S	5,871.74
CAT50	GPV13	ER20	130	35	80	13	M10	4,000	4.2	381200S	5,871.74
BT40	GPV13	ER20	130	35	65	13	M10	4,000	4.2	381202S	5,871.74
BT50	GPV13	ER20	136	41	80	13	M10	4,000	4.2	381204S	5,871.74
HSK63	GPV13	ER20	137	42	65	13	M10	4,000	4.2	381206S	4,745.65
HSK100	GPV13	ER20	140	45	80	13	M10	4,000	4.2	381208S	6,228.94

Other tapers available, please inquire.

\* For Haas machines please contact Customer Service

Technical Data	GPV13
Ratio	1:1
RPM Max	4,000
Max axial load	N 450
Torque	Nm 6
Weight	Kg. 4.2
Collet	mm ER20 1mm-13mm

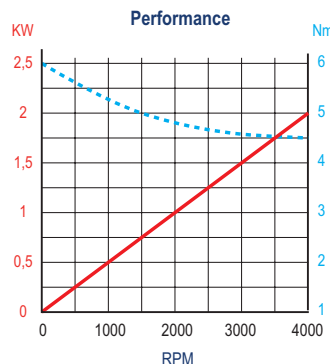

#### Standard Features & Equipment Included:

- Internal coolant from positioning pin
- Internal air pressure
- Retaining block
- Wrenches
- Grease tube
- Instruction book and Inspection report

