

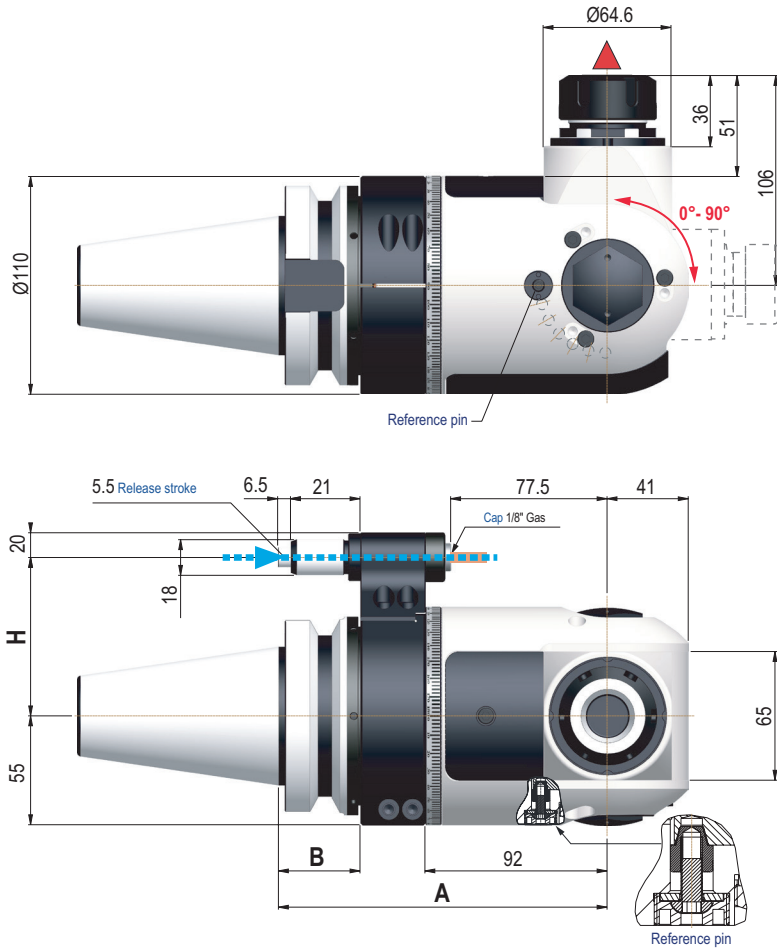

# ANGLE HEADS

# ATC Series

## GPV20



### GPV20 ER32 Pivoting Angle Heads

▼ Direction of rotation is opposite to the machine spindle



| Taper  | Model | Collet System | A (mm) | B (mm) | H (mm) | End Mill & Drill Cap. (mm) | Tap Size Capacity | Max RPM | Weight (Kg.) | Code No. | Price \$ |
|--------|-------|---------------|--------|--------|--------|----------------------------|-------------------|---------|--------------|----------|----------|
| CAT50  | GPV20 | ER32          | 160    | 35     | 80     | 20                         | M16               | 4,000   | 13           | 381150S  | 6,367.02 |
| BT50   | GPV20 | ER32          | 166    | 41     | 80     | 20                         | M16               | 4,000   | 13           | 381154S  | 6,367.02 |
| HSK100 | GPV20 | ER32          | 170    | 45     | 80     | 20                         | M16               | 4,000   | 13           | 381158S  | 6,707.89 |

Other tapers available, please inquire.

\* For Haas machines please contact Customer Service

| Technical Data |     | GPV20         |
|----------------|-----|---------------|
| Ratio          |     | 1:1           |
| RPM Max        |     | 4,000         |
| Max axial load | N   | 715           |
| Torque         | Nm  | 32            |
| Weight         | Kg. | 13            |
| Collet         | mm  | ER32 3mm-20mm |

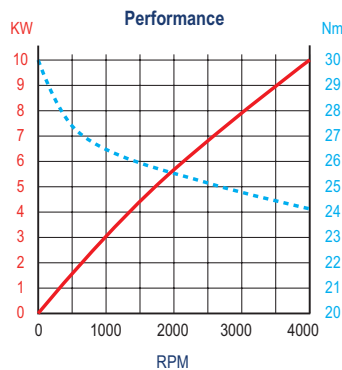

#### Standard Features & Equipment Included:

- Internal coolant from positioning pin
- Internal air pressure
- Retaining block
- Wrenches
- Grease tube
- Instruction book and Inspection report

