

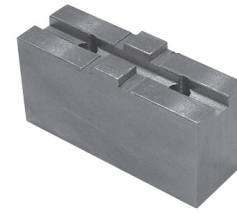

Soft Top Jaws — Metric Tongue & Groove

- For SMW/Autoblok, Berg, Forkardt, Rohm, Schunk

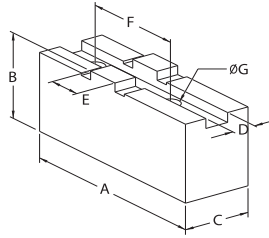

Model No.	Chuck Dia.	A (mm)	B (mm)	C (mm)	D (mm)	E (mm)	F (mm)	G (mm)	Weight kg.	Code No.	Individual Price \$
232200/F	160	85	40	20	8	18	32	9	0.38	491095	39.85
232201/F	200	105	50	25	10	20	40	9	0.62	491102	44.08
232202/F	250	125	50	30	12	20	40	13	1.12	491105	56.30
232203/F	315	145	60	35	12	26	54	13	1.93	491115	77.54
232204/F	400	180	80	50	18	30	60	17	4.56	491125	139.77

Soft Top Jaws — American Tongue & Groove

- For Rohm Models ZG, ZS, ZGU, ZSU

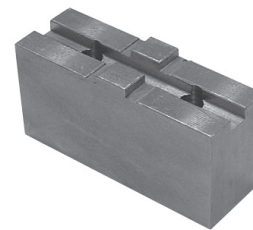
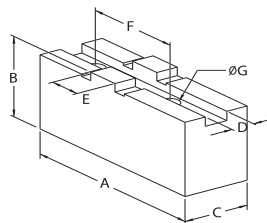

Model No.	Chuck Dia.	A (mm)	B (mm)	C (mm)	D (mm)	E (mm)	F (mm)	G (mm)	Weight kg.	Code No.	Individual Price \$
262200/R	100	53	30	25	7.96	9.49	24	7	0.24	491151	38.71
262201/R	125	62	40	25	7.96	12.67	32	9	0.36	491155	41.34
262202/R	160	74	45	30	7.96	12.67	38.1	9	0.61	491160	47.97
262203/R	200	87	45	30	7.96	12.67	44.45	9	0.76	491165	51.04
262204/R	250	103	50	35	12.72	19.02	53.95	13	1.1	491170	55.73
262205/R	315	120	60	40	12.72	19.02	63.50	13	1.87	491180	69.55
262205/R	315	140	60	40	12.72	19.02	63.50	13	2.2	491181	117.05
262206/R	350-400	140	70	50	12.72	19.02	76.20	17	3.0	491190	133.72
262207/R	450-800	160	80	50	12.72	19.02	76.20	21	3.5	491195	175.86

Soft Jaw Forming Ring

The forming ring is used for cutting soft jaws by clamping and extending the through hole to increase the accuracy of clamping the workpiece.

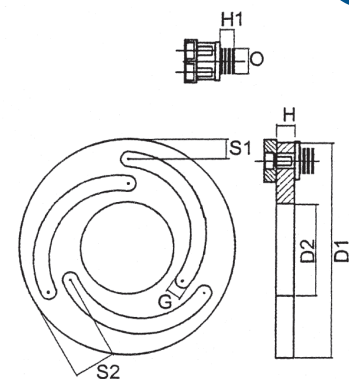
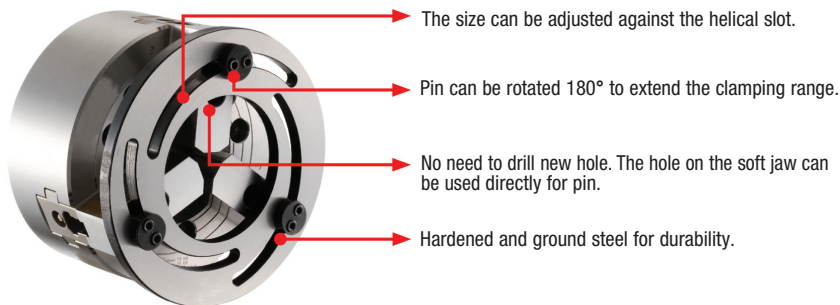

Model No.	For Chuck Dia.	H (mm)	D1 (mm)	D2 (mm)	S1 (mm)	S2 (mm)	G (mm)	H1 (mm)	O (mm)	Weight kg.	Code No.	Price \$
VFR-05	5"	12	140	60	12	28	10	9	13.5	1	326250	300.43
VFR-06	6"	12	168	80	12	32	10	9	16.5	1.5	326255	408.49
VFR-08	8"	12	218	115	17	36	10	9	18.5	2.4	326260	470.37
VFR-10	10"	12	258	150	15	40	10	9	18.5	3.2	326265	495.32
VFR-12	12"	15	316	118	21	50	10	9	21.5	5	326270	742.69