

80° Bull Nose Live Centres — Standard Point

Features

- Accuracy guaranteed to 0.003mm TIR (0.0001")
- Excellent for heavy duty lathe applications
- Heat treated point to 60±2HRC
- For pipe work, tube work, and part with extra-large centre holes
- Triple Bearing System: a taper roller bearing, thrust bearing, and a high-precision radial ball bearing combine to provide excellent rigidity and superior performance
- The design prevents ingress of coolant and chips
- Shaft borehole for easy, efficient dismounting
- Drop forged shaft (50±2HRC)

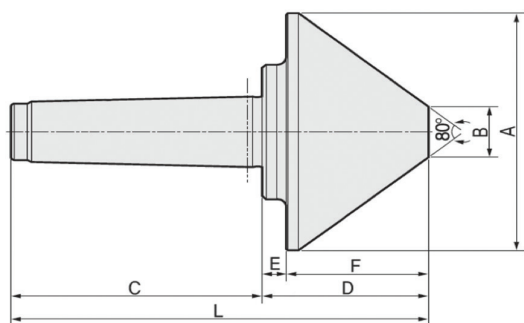

- MT4
- MT5

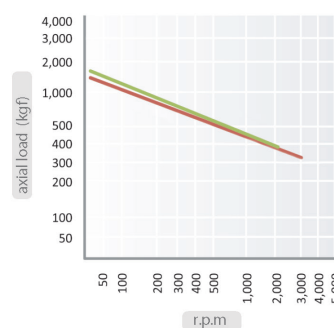
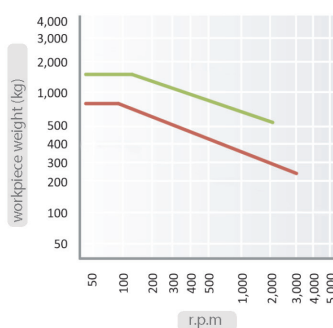

Dimensions

MT	A (mm)	B (mm)	C (mm)	D (mm)	E (mm)	F (mm)	L (mm)	Workpiece Weight	Max RPM	Weight	Max Runout	Code No.	Price \$
4	125	29	108	77	13	64	185	800 kg	3,000	3.9 kg	0.003mm	311036	884.56
5	150	32	136	90	13	77	226	1,600 kg	2,000	6.9 kg	0.003mm	311035	1,414.91



Indexable External Turning Toolholders

Requires fewer tool changes than solid tools in high level metalworking.

See Pages E44-E59

