

## GS Multi-Tasking Modular Vises for 5-Axis Machining Centers

The MULTI-TASKING range of vises has been specially designed for 5-axis machines. Working on 5 sides of the workpiece, it allows the best optimization of the machining cycle. Thanks to the compact design this kind of vise can be installed on all machining centres. The use of GRIP jaws is strongly recommended with multitasking vises.

- Self-centering or eccentric
- Eccentric jaw adjustment in steps of 2mm
- Highest accuracy in positioning and alignment ( $\pm 0.02\text{mm}$ ) due to ground rack teeth on both the base and the fixed jaws
- Minimum deflection
- Solid, rigid construction and maximum clamping ratio to the total length
- Positioning through ground holes or keyways
- All case hardened to 60HRC for durability



Type 1 & 2



Type 3

Vise shown with riser

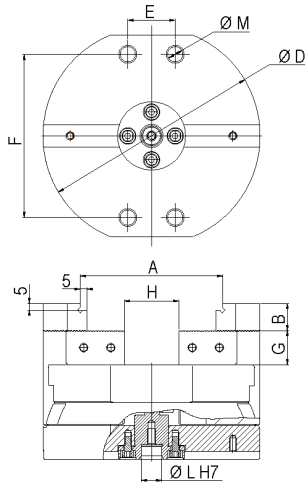

Type 1 & 2

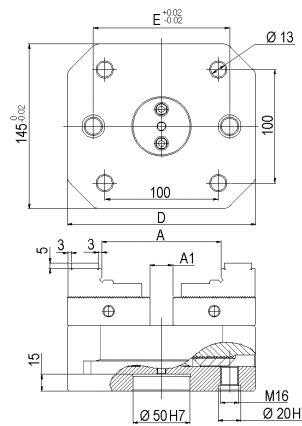
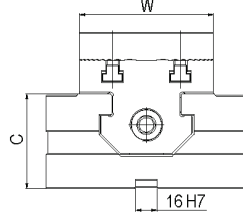

Type 3

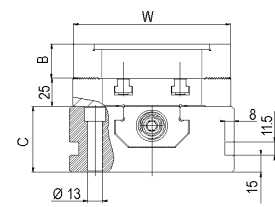

	Type 1	Type 2	Type 3x166	Type 3x266
<b>Code No.</b>	<b>382520</b>	<b>382522</b>	<b>382524</b>	<b>382526</b>
<b>Price \$</b>	<b>2,244.08</b>	<b>2,991.86</b>	<b>3,440.75</b>	<b>3,590.37</b>
A	74	104	108	208
A1	-	-	20	60
W	74	99	138	138
B	15	20	30	30
C	50	70	58	58
ØD/D	120	160	166	266
E	5	35	120	200
F	92	120	-	-
G	20	25	-	-
H	20	40	-	-
ØL H7	20	20	-	-
M	9	11	-	-
kg	4.9	11	13	20
kN	16	20	30	30



Also available:

Smooth, Soft, Serrated, Step,  
Prismatic, and Grip Jaws

Call for more information

