



WELDING & METALWORKING



Abrasives	912 - 938
Brushes	939 - 947
Cutting Tools	948 - 991
Parts Cleaners.....	992 - 995
Lubricating Equipment.....	996 - 1001
Chemicals	1002 - 1037
Paint & Painting Supplies.....	1038 - 1054
Sandblasting & Fume Extractors	1055 - 1061
Gas Equipment & Accessories	1062 - 1075
Reels & Welding Accessories.....	1076 - 1079
Soldering Tools & Accessories	1080 - 1083
Arc Tools & Accessories	1084 - 1089
Welding Machines	1090 - 1093
MIG Guns & Accessories	1094 - 1099
TIG Torches & Accessories.....	1100 - 1114
Pipe Layout Measuring Tools	1115 - 1117
Welding Screens & Blankets	1118 - 1119
Welding Helmets & Lenses	1120 - 1128
Welding Clothing & Gloves.....	1129 - 1134
Alloys & Fluxes.....	1135 - 1141
Metal Working Fluids & Equipment.....	1142 - 1153





REINFORCED CUT-OFF WHEELS

Typical Applications

- Cutting sheet metal
- Cutting pipe
- Foundry/forge shops – gate/riser removal, cutting forgings
- Metal plate dimensioning
- Ship building – metal fabrication
- Tool room – cutting drill bits, steel bar, tubing, metallurgical sectioning
- Construction – concrete/masonry work

To be used with:

- Portable grinder small diameter (2" - 4")
- Right angle grinder (4" - 9")
- Circular saw (6" - 8")
- High-speed gas/electric saw (12" - 16")
- Stationary machine large diameter (10" - 30")
- Chop saw (10" - 16")

PORTABLE SMALL DIAMETER REINFORCED CUT-OFF WHEELS



NORZON PLUS TYPE 01

- Patented Norton SG (ceramic alumina)/NorZon (zirconia alumina) grain combination
- Highly advanced bond system
- State-of-the-art manufacturing
- NorZon Plus: Up to 3x life versus aluminum oxide wheels on carbon steel, stainless and cast iron, 40% faster cut rate versus standard aluminum oxide wheels
- Superior wheel balance



Model No.	Mfg. No.	D" x T" x A"	Max RPM	Price /Each
NS138	C0303514NZZ	3 x 1/32 x 1/4	25 465	5.90
NS139	C0303538NZZ	3 x 1/32 x 3/8	25 465	5.90
NS140	C0311614NZZ	3 x 1/16 x 1/4	25 465	5.90
NS142	C0311638NZZ	3 x 1/16 x 3/8	25 465	5.90
NS145	C031838NZZ	3 x 1/8 x 3/8	25 465	7.23
NR003	C0403538NZZ	4 x 1/32 x 3/8	19 100	8.11
NR004	C0411614NZZ	4 x 1/16 x 1/4	19 100	8.11
NR005	C0411638NZZ	4 x 1/16 x 3/8	19 100	8.11
NR006	C041838NZZ	4 x 1/8 x 3/8	19 100	10.80

GEMINI TYPE 01

- Advanced formulation
- Free cutting
- Maximizes the performance of conventional aluminum oxide abrasive
- Engineered to cut hard materials



Model No.	Mfg. No.	D" x T" x A"	Max RPM	Price /Each
NS172	C0303514GFC	3 x 1/32 x 1/4	25 465	2.12
NS174	C0303538GFC	3 x 1/32 x 3/8	25 465	2.12
NS176	C0311614GFC	3 x 1/16 x 1/4	25 465	2.12
NS178	C0311638GFC	3 x 1/16 x 3/8	25 465	2.12
NS180	C031814GFC	3 x 1/8 x 1/4	25 465	3.30
NS182	C031838GFC	3 x 1/8 x 3/8	25 465	3.39
NS184	C0403514GFC	4 x 1/32 x 1/4	19 100	2.91
NS186	C0403538GFC	4 x 1/32 x 3/8	19 100	2.91
NS188	C0411614GFC	4 x 1/16 x 1/4	19 100	2.91
NS189	C0411638GFC	4 x 1/16 x 3/8	19 100	2.91
NS191	C041814GFC	4 x 1/8 x 1/4	19 100	4.09
NS192	C041838GFC	4 x 1/8 x 3/8	19 100	3.97

D x T x A: Diameter x Thickness x Arbor Size

BASIC 2 IN 1

- Basic fast-cut
- Used in various applications
- For use on steel & stainless steel



Model No.	Mfg. No.	D" x T" x A"	Max RPM	Price /Each
TYPE 01				
NU421	222899	4 1/2 x 1/16 x 7/8	13 300	2.42
NU422	222900	5 x 1/16 x 7/8	12 250	2.54
TYPE 27				
NU419	222858	4 1/2 x 1/4 x 7/8	13 300	3.05
NU420	222860	5 x 1/4 x 7/8	12 250	3.30

PREMIUM 2 IN 1 THINCUT

- Superior comfort and performance
- Offers a fast, cool and burr free cut
- Free cutting reduces workload and increases productivity
- Highly reinforced cutting wheel
- For use on steel & stainless steel



Model No.	Mfg. No.	D" x T" x A"	Max RPM	Price /Each
TYPE 01				
NU404	384142	4 1/2 x 3/64 x 7/8	13 300	3.26
NU405	384143	5 x 3/64 x 7/8	12 250	3.32
NU406	401205	6 x 3/64 x 7/8	10 200	4.27
TYPE 27				
NU554	34042238	4 1/2 x 3/64 x 7/8	13 300	3.26
NU397	34042239	5 x 3/64 x 7/8	12 250	3.32
NU408	34042240	6 x 3/64 x 7/8	10 200	4.27

CUBITRON™ II CUT-OFF WHEELS

- Designed to provide high cut rates and long life on all types of ferrous metals, stainless steels, alloy steels and cast iron
- Cool cutting for a higher quality and faster cut
- Fast cool cutting helps extend the life of the tool



Model No.	Mfg. No.	D" x T" x A"	Max RPM	Price /Each
TYPE 01				
NU222	051115-66518	4 x 0.035 x 3/8	19 100	5.65
NU224	051115-66520	4 x 0.06 x 3/8	19 100	6.28
NU225	051115-66521	4 x 0.09 x 5/8	15 300	5.93
NU226	051115-66522	4 x 0.045 x 5/8	15 300	6.27
NU228	051115-66524	4 x 0.125 x 3/8	19 100	8.18
NU229	051115-66525	4 1/2 x 0.045 x 7/8	13 300	4.45
NU230	051115-66526	5 x 0.045 x 7/8	12 250	5.05
NU231	051115-66527	6 x 0.045 x 7/8	10 200	5.35
NU232	051115-66528	7 x 0.045 x 7/8	8 500	7.28
TYPE 27				
NU233	051115-66529	4 x 0.045 x 5/8	15 300	6.28
NU362	051115-66531	4 1/2 x 0.045 x 7/8	13 300	4.70
NU236	051115-66535	4 1/2 x 0.125 x 7/8	13 300	7.77
NU237	051115-66537	5 x 0.045 x 7/8	12 250	5.52
NU238	051115-66539	5 x 0.09 x 7/8	12 250	5.85
NU363	051115-66541	6 x 0.045 x 7/8	10 200	5.97
NU240	051115-66543	7 x 0.09 x 7/8	8 500	10.80

RIGHTCUT EVO

- Quality aluminum oxide grain
- Consistent performance at a competitive price
- Ideal for small jobs on a variety of metal applications from carbon to stainless steels
- Unique reinforcement design
- Provides safety, strength and straight cuts
- Extra thin
- Quick cutting action and low kerf loss



NORTON

Model No.	Mfg. No.	Size			Max RPM	Price /Each
		D" x	T" x	A"		
TYPE 01						
NS003	RC5G	5 x	3/64 x	7/8	12225	4.32
NS211	RC7G	7 x	1/16 x	7/8	8730	6.03
TYPE 27						
NS093	RC45G27	4 1/2 x	3/64 x	7/8	13580	2.87
NS094	RC5G27	5 x	3/64 x	7/8	12225	3.39
NS096	RC7G27	7 x	1/16 x	7/8	8730	4.62

BLUEFIRE RIGHT ANGLE GRINDERS

- Upgraded zirconia alumina grain chemistry and shape, blended with premium aluminum oxide grain provides 2-3 times the life of aluminum oxide wheels
- Broad utility: from light- to heavy-pressure applications, on a wide range of materials: stainless steel, carbon steel, and alloys, to grey iron



NORTON

Model No.	Mfg. No.	Size			Max RPM	Price /Each
		D" x	T" x	A"		
TYPE 01						
NR991	66252843208	4 1/2 x	0.045 x	7/8	13580	3.60
N0015	66252843209	5 x	0.045 x	7/8	12225	3.95
TYPE 27						
NR994	66252843219	4 1/2 x	0.045 x	7/8	13580	3.83
N0018	66252843220	5 x	0.045 x	7/8	12225	4.59

NORZON PLUS RIGHTCUT

- High performance, proprietary ceramic and zirconia alumina abrasives blend
- Far fewer wheel changes required so job is completed faster
- Ideal for applications on steel and stainless steel
- Extra thin, quick cutting action; minimal low kerf loss



NORTON

Model No.	Mfg. No.	Size			Max RPM	Price /Each
		D" x	T" x	A"		
TYPE 01						
NS194	66252830730	4 1/2 x	0.045 x	7/8	13580	5.55
NS195	66252830731	5 x	0.045 x	7/8	12225	6.30
NS196	66252842008	6 x	0.045 x	7/8	10185	6.82
TYPE 27						
NS197	66252843320	4 1/2 x	0.045 x	7/8	13580	6.47
NS198	66252843329	5 x	0.045 x	7/8	12225	7.01
NS199	66252842009	6 x	0.045 x	7/8	10185	7.23

HIGH SPEED REINFORCED CUT-OFF WHEELS

- **Universal arbor:** 1"/20-mm knock out arbor fits all gas and electric high speed saws, 20-mm bushing is pre-mounted into the 1" hole use as is for a 20-mm arbor or remove bushing for a 1" arbor (once bushing is removed, cannot be replaced)
- **Asphalt:** Special blend of extra coarse silicon carbide ideal for cutting asphalt, green concrete, wide range of aggregates and abrasive materials
- **Concrete:** Coarse grit silicon carbide for cutting brick, block, concrete and other masonry products
- **Ductile:** Special blend of silicon carbide and aluminum oxide ideal for cutting ductile, cast iron pipe, concrete lined water pipes, sewer construction and heavy-duty PVC
- **Metalworking:** High performance aluminum oxide ideal for general purpose cutting of steel and stainless steel parts (rebar, steel pipe, structural steel, sheet metal, etc)



NORTON

Model No.	Mfg. No.	Size			Max RPM	Price /Each
		D" x	T" x	A"		
FOR ASPHALT						
NR146	70184670243	12 x	1/8 x	1 1/2" 20 mm	6360	9.35
NR147	70184672877	14 x	1/8 x	1 1/2" 20 mm	5400	13.50
FOR CONCRETE						
NR865	66252837839	12 x	1/8 x	1 1/2" 20 mm	6360	7.07
NR868	66252837842	14 x	1/8 x	1 1/2" 20 mm	5400	10.70
NS234	70184623029	16 x	1/8 x	1 1/2" 20 mm	4800	19.60
FOR DUCTILE						
NR866	66252837840	12 x	1/8 x	1 1/2" 20 mm	6360	7.53
NR869	66252837843	14 x	1/8 x	1 1/2" 20 mm	5400	11.40
FOR METALWORKING						
NR864	66252837838	12 x	1/8 x	1 1/2" 20 mm	6360	7.07
NR867	66252837841	14 x	1/8 x	1 1/2" 20 mm	5400	10.70

LARGE DIAMETER REINFORCED CUT-OFF WHEELS FOR STATIONARY SAWS



GEMINI LARGE DIAMETER TYPE 01

- Quality aluminum; sets the aluminum oxide industry standard for cutting all oxide abrasive material in metal fabrication applications



NORTON

Model No.	Mfg. No.	Size			Max RPM	Price /Each
		D" x	T" x	A"		
GEMINI FREE CUT						
NS242	C01418GFC	14 x	1/8 x	1	4365	23.40
NS244	C016532GFC	16 x	5/32 x	1	3820	32.00
NS246	C018532G	18 x	5/32 x	1	3015	54.20
NS247	C020532GFC	20 x	5/32 x	1	2710	53.40
NS249	C020316GFC	20 x	3/16 x	1	2710	58.80
GEMINI LONG LIFE						
NS241	C01218GLL	12 x	1/8 x	1	5095	15.60
NS243	C01418GLL	14 x	1/8 x	1	4365	23.40
NS245	C016532GLL	16 x	5/32 x	1	3820	32.00
NS248	C020532GLL	20 x	5/32 x	1	2710	53.40
NS250	C020316GLL	20 x	3/16 x	1	2710	58.80

D x T x A: Diameter x Thickness x Arbor Size

OFFICE PRODUCTS

INSTRUMENTS, SCALES & ELECTRICAL

SHIPPING & PACKAGING

TOOLS & EQUIPMENT

WELDING & METALWORKING

SAFETY EQUIPMENT & SUPPLIES

JANITORIAL & MAINTENANCE

MATERIAL HANDLING & STORAGE

CIRCULAR SAW REINFORCED CUT-OFF WHEELS



MASONRY & METAL TYPE 01

- Versatile, ideal for slotting and cutting when initial cost is a main consideration
- Gemini all purpose:** Quality aluminum oxide abrasive, sets the aluminum oxide general purpose industry standard for cutting rough sides all material in metal fabrication applications
- Norton masonry:** Sharp, silicon carbide grain, engineered for all masonry materials such as concrete, brick and asphalt
- Norton metal:** Quality aluminum oxide abrasive, designed for cutting alloys, steels and ferrous metals



NORTON

Model No.	Mfg. No.	D" x T" x A"	Description	Max RPM	Price /Each
NS216	C0716G	7 x 1/16 x 5/8	Metal	8730	5.42
NS217	C0718M	7 x 1/8 x DM*	Metal	8730	3.41
NS218	C0718MA	7 x 1/8 x DM*	Masonry	8730	3.58
NS220	C0816G	8 x 1/16 x 5/8	Metal	7640	6.42
NS221	C0818M	8 x 1/8 x DM*	Metal	7640	4.10
NS222	C0818MA	8 x 1/8 x DM*	Masonry	7640	4.62

* DM: denotes diamond mount; 5/8" hole bushing included

CHOP SAW REINFORCED CUT-OFF WHEELS



BLUEFIRE CHOP SAW WHEELS

- Upgraded zirconia alumina grain chemistry and shape, blended with premium aluminum oxide grain provides 2-3 times the life of aluminum oxide wheel.
- Broad utility: from light to heavy pressure applications, on a wide range of materials: stainless steel, carbon steel and alloys, to gray iron
- Excellent performance-to-price ratio lowers total grinding costs
- Long Life:** Side reinforced; ideal for small cross-section work pieces, resist breakage and provide straight cuts
- Rapid Cut:** Centrally reinforced, non-binding, free-cutting, rough sides, burr- and burr-free cuts



NORTON

Model No.	Mfg. No.	Additional Description	Size D" x T" x A"	Max RPM	Price /Each
NR0021	66252843250		12 x 3/32 x 1	5095	15.70
NR996	66252843253	Long Life	14 x 3/32 x 1	4365	20.90
NR0010	66252843254	Rapid Cut	14 x 3/32 x 1	4365	20.90
NR987	66252843257	Long Life	16 x 3/32 x 1	3820	30.60

14" ABRASIVE CHOP SAWS

- Powerful 15 Amp, 4.0 max. HP motor: Delivers maximum cutting performance in a wide variety of materials
- Large cutting capacity: Provides versatility for a wide range of cutting applications, up to 5" pipe
- 45° miter capacity with adjustable fence
- Quick adjust vise clamp: Allows clamp to be adjusted quickly when cutting different material sizes
- All ball bearing construction: Delivers maximum durability
- Includes:** Chop saw, vise, abrasive wheel, hex wrench

Model No. TLV202
Mfg. No. 6177-20
Price/Each \$276.00

SPECIFICATIONS

Amperage:	15.0
Motor Horsepower:	4.0
No Load RPM:	3900
Blade Diameter:	14"
Tool Weight:	40.0 lbs.



Milwaukee

PERFORMANCE PLUS 14" CHOP SAWS

- Ball bearing induction motor
- Spark deflector for safe operation
- Quick release vise for holding workpiece, which allows cuts up to a 45° angle

Model No. WK772
Mfg. No. 8342
Price/Each \$195.00

SPECIFICATIONS

Amperage:	15.0
No Load RPM:	3750
Blade Diameter:	14"
Max. Depth of Cut:	4"
Max. Width of Cut:	7 1/4"
Tool Weight:	45.0 lbs.



KING
SAWS

GEMINI TYPE 01

- Free Cut:** side reinforced; engineered for larger cross-sections and/or hard-to-cut materials, resist breakage and provide straight cuts
- Long Life:** side reinforced; ideal for small cross-section work pieces, resist breakage and provide straight cuts
- Rapid Cut:** centrally reinforced; free cutting, non-binding; burr- and burn-free cuts rough sides
- Aluminum:** specially formulated bond for aluminum and other soft, nonferrous metals, no wax or rubber fillers; free cutting, resists loading, no surface contamination



NORTON

Model No.	Mfg. No.	Size D" x T" x A"	Max RPM	Price /Each
GEMINI LONG LIFE				
NS255	C010764G	10 x 3/32 x 1	6110	10.70
NS256	C012764G	12 x 3/32 x 1	5095	8.58
NS259	C014764GLL	14 x 3/32 x 1	4365	10.70
NS261	C016764G	16 x 3/32 x 1	3820	18.70
GEMINI RAPID CUT				
NS257	C012764GRC	12 x 3/32 x 1	5095	7.53
NS260	C014764GRC	14 x 3/32 x 1	4365	9.46
GEMINI ALUMINUM				
NS258	C014764GALU	14 x 3/32 x 1	4365	13.70

FAST-CUT TYPE 01

- All purpose, thin or heavy gauge cutting
- Fast cutting
- Non glazing on thin or heavy gauges
- For use on steel & stainless steel



TYROLIT

Model No.	Mfg. No.	Size D" x T" x A"	Max RPM	Price /Each
NU402	20041210	14 x 3/32 x 1	4400	8.77

D x T x A: Diameter x Thickness x Arbor Size

DEPRESSED CENTRE GRINDING WHEELS

Typical Applications

- Metal fabrication
- Petrochemical maintenance
- All-weld grinding
- Shipbuilding
- Foundry – notching and removing gates and risers
- Pipeline – root pass grinding, pipe bevelling and repair
- Construction – masonry/concrete fabrication



NORZON PLUS TYPE 27

- Premium, combination of Norton SG (ceramic aluminum oxide) and NorZon (zirconia alumina)
- Up to 10 times the performance of aluminum oxide wheels
- Advanced bond system providing the fastest cutting zirconia wheel on the market; easy on the operator and equipment



Model No.	Mfg. No.	Size D" x T" x A"	Max RPM	Price /Each
FOR STEEL CUTTING/NOTCHING & LIGHT GRINDING				
NS053	DC4518NZP	4 1/2 x 1/8 x 7/8	13 580	10.10
NS054	DC518NZP	5 x 1/8 x 7/8	12 225	11.40
NS055	DC718NZP	7 x 1/8 x 7/8	8600	14.80
NS056	DC918NZP	9 x 1/8 x 7/8	6600	19.10
FOR STEEL GRINDING				
NS044	DC4514NZP	4 1/2 x 1/4 x 7/8	13 580	10.90
NS039	DC514NZP	5 x 1/4 x 7/8	12 225	12.60
NS059	DC614NZP	6 x 1/4 x 7/8	10 185	15.40
NS036	DC714NZP	7 x 1/4 x 7/8	8600	16.20
NS032	DC914NZP	9 x 1/4 x 7/8	6600	21.90

BLUEFIRE TYPE 27

- Upgraded zirconia alumina grain chemistry and shape, blended with premium aluminum oxide grain provide 2-3 times the life of aluminum oxide wheels
- Broad utility: from light- to heavy-pressure applications, on a wide range of materials: stainless steel, carbon steel, and alloys, to gray iron
- Excellent performance-to-price ratio lowers total grinding costs
- Contaminate-free INOX wheels contain <0.1% iron, sulfur, or chlorine for rust-free and corrosion-free results; will not contaminate stainless steel
- Foundry wheels have zirconia alumina/silicon carbide abrasive and an exceptionally strong reinforcement structure



Model No.	Mfg. No.	Size D" x T" x A"	Max RPM	Price /Each
FOR STEEL CUTTING/NOTCHING & LIGHT GRINDING				
NR992	66252843212	4 1/2 x 1/8 x 7/8	13580	5.55
NO016	66252843216	5 x 1/8 x 7/8	12225	6.30
NO014	66252843202	6 x 1/8 x 7/8	10185	8.46
NO031	66252843234	7 x 1/8 x 7/8	8600	9.25
NO020	66252843245	9 x 1/8 x 7/8	6600	14.30
FOR STEEL GRINDING				
NR981	66252843214	4 1/2 x 1/4 x 7/8	13580	5.92
NO017	66252843218	5 x 1/4 x 7/8	12225	6.74
NO005	66252843203	6 x 1/4 x 7/8	10185	8.61
NO032	66252843236	7 x 1/4 x 7/8	8600	9.98
NR985	66252843247	9 x 1/4 x 7/8	6600	15.80

NORTON METAL TYPE 27

- Quality aluminum oxide abrasive, ideal for grinding alloys, metals, steels and ferrous metals
- Ideal for on site and small unit job
- Type 27



NORTON METAL GRINDING WHEELS

Model No.	Mfg. No.	Size D" x T" x A"	Max RPM	Price /Each
FOR STEEL CUTTING/NOTCHING & LIGHT DEBURRING				
NR881	DC4518M	4 1/2 x 1/8 x 7/8	13 580	1.95
NR882	DC518M	5 x 1/8 x 7/8	12 225	3.04
NR883	DC718M	7 x 1/8 x 7/8	8600	4.62
FOR GRINDING				
NS130	DC4514M	4 1/2 x 1/4 x 7/8	13 580	2.10
NS132	DC514M	5 x 1/4 x 7/8	12 225	2.91
NS134	DC714M	7 x 1/4 x 7/8	8600	4.34

BLUEFIRE DEPRESSED CENTER WHEELS

- Upgraded zirconia alumina grain chemistry and shape, blended with premium aluminum oxide grain provides 2-3 times the life of aluminum oxide wheel.
- Broad utility: from light to heavy pressure applications, on a wide range of materials: stainless steel, carbon steel and alloys, to grey iron
- Excellent performance-to-price ratio lowers total grinding costs
- Will not contaminate stainless steel



Model No.	Mfg. No.	Size D" x T" x A"	Max RPM	Price /Each
FOR CUTTING/NOTCHING & LIGHT GRINDING				
NR989	66252843190	4 1/2 x 1/8 x 7/8	13580	5.16
NO027	66252843194	5 x 1/8 x 7/8	12225	5.74
NO030	66252843198	6 x 1/8 x 7/8	10185	7.26
NO025	66252843182	7 x 1/8 x 7/8	8600	8.56
FOR GRINDING				
NR978	66252843192	4 1/2 x 1/4 x 7/8	13580	5.42
NO028	66252843196	5 x 1/4 x 7/8	12225	5.86
NR990	66252843200	6 x 1/4 x 7/8	10185	7.59
NO026	66252843184	7 x 1/4 x 7/8	8600	9.23
NO004	66252843188	9 x 1/4 x 7/8	6600	13.70

CUBITRON™ II TYPE 27

- Produces very high cut rates on a wide variety of metals
- Used for heavy weld removal and many other grinding applications
- 3M precision-shaped grain for ultra fast cut and long life
- Specially formulated for use on stainless and mild steel
- Cool cutting for higher quality and faster cut



Model No.	Mfg. No.	Size D" x T" x A"	Max RPM	Price /Each
NU206	051115-66598	4 x 1/4 x 3/8	15300	8.67
NU207	051115-66597	4 x 1/4 x 5/8	15300	8.67
NU208	051115-66587	4 1/2 x 1/4 x 7/8	13300	8.98
NU205	051115-66588	5 x 1/4 x 7/8	12250	10.37
NU209	051115-66589	6 x 1/4 x 7/8	10000	12.70
NU210	051115-66590	7 x 1/4 x 7/8	8500	13.30
NU211	051115-66591	9 x 1/4 x 7/8	6650	18.00

D x T x A: Diameter x Thickness x Arbor Size

OFFICE PRODUCTS

INSTRUMENTS, SCALES & ELECTRICAL

SHIPPING & PACKAGING

TOOLS & EQUIPMENT

WELDING & METALWORKING

SAFETY EQUIPMENT & SUPPLIES

JANITORIAL & MAINTENANCE

MATERIAL HANDLING & STORAGE

ABRASIVES

GEMINI ALUMINUM OXIDE TYPE 27

- Quality aluminum oxide
- Consistent, maximum performance of aluminum oxide wheels at a competitive price
- Ideal for small job shops on a variety of metalworking applications
- **Gemini Aluminum:** Contains no wax or rubber fillers for grinding aluminum and soft metals without loading



NORTON

Model No.	Mfg. No.	D" x T" x A"	Size	Max RPM	Price /Each
FOR STEEL CUTTING, NOTCHING & LIGHT GRINDING					
NS106	DC4518G	4 1/2 x 1/8 x 7/8		13 580	2.54
NS040	DC518G	5 x 1/8 x 7/8		12 225	4.16
NS107	DC618G	6 x 1/8 x 7/8		10 185	5.57
NS108	DC718G	7 x 1/8 x 7/8		8 600	5.51
NS109	DC918G	9 x 1/8 x 7/8		6 600	7.52
FOR METAL & STEEL GRINDING					
NS042	DC4514G	4 1/2 x 1/4 x 7/8		13 580	2.62
NS037	DC514G	5 x 1/4 x 7/8		12 225	4.41
NS114	DC614G	6 x 1/4 x 7/8		10 185	5.53
NS116	DC714GFC	7 x 1/4 x 7/8		8 600	5.92
NS033	DC914GFC	9 x 1/4 x 7/8		6 600	8.79
GEMINI ALUMINUM					
NS121	DC4514GALU	4 1/2 x 1/4 x 7/8		13 580	7.57
NS122	DC514GALU	5 x 1/4 x 7/8		12 225	8.02
NS123	DC714GALU24	7 x 1/4 x 7/8		8 600	10.60

CUBITRON™ II CUT AND GRIND WHEEL TYPE 27

- 3M precision-shaped grain for ultra fast cut and long life
- Versatile – use as both a grinding wheel and cut-off wheel
- Specially formulated for use on stainless and mild steel
- Cool cutting for a higher quality and faster cut



3M

Model No.	Mfg. No.	D" x T" x A"	Size	Max RPM	Price /Each
NU358	82279	4 1/2 x 1/8 x 7/8		13 300	9.27
NU357	82278	5 x 1/8 x 7/8		12 250	10.68
NU355	28758	6 x 1/8 x 7/8		10 200	13.03
NU356	28760	7 x 1/8 x 7/8		8 500	13.67
NU361	28761	9 x 1/8 x 7/8		6 650	18.48

PREMIUM 2 IN 1 TYPE 27

- Offers comfort, high stock removal and long life
- Fast removal & operator comfort
- Used in various applications
- Exclusive blend of bonding & grain system
- For use on steel & stainless steel



TYROLIT

Model No.	Mfg. No.	D" x T" x A"	Size	Max RPM	Price /Each
NU410	5293	4 1/2 x 9/32 x 7/8		13 300	4.21
NU411	5313	5 x 9/32 x 7/8		12 250	4.60
NU412	5330	6 x 9/32 x 7/8		10 200	5.80

D x T x A: Diameter x Thickness x Arbor Size

916

MATERIAL HANDLIN & STORAGE

JANITORIAL & MAINTENANCE

SAFETY EQUIPMENT & SUPPLIES

WELDING & METALWORKING

TOOLS & EQUIPMENT

SHIPPING & PACKAGING

INSTRUMENTS, SCALES & ELECTRICAL

OFFICE PRODUCTS

LARGE ANGLE GRINDERS TRIGGER GRIP W/LOCK-ON OR NON LOCK-ON

- Debris baffles protect internal components by deflecting damaging debris out of the airflow at the intake vents
- External brush doors reduce service time by providing easy access to brushes
- Soft-grip main handle provides better control and comfort
- **Includes:** Side handle, 7" and 9" type 27 guard and spanner wrench

Model No. TLZ819
Mfg. No. 6088-30
Price/Each \$254.00



SPECIFICATIONS

Wheel Diameter: 7" to 9"
Voltage: 120 V
Amperage: 15 Amp
No Load RPM: 6000
Spindle Size: 5/8"
Tool Weight: 13.7 lbs.
Trigger, Non Lock-On
Model No.: TLZ820

ROTO™ LARGE ANGLE GRINDERS TRIGGER GRIP W/LOCK-ON OR NON LOCK-ON

- 9-position rotating handle allows the user to adjust the main handle for better control
- Debris baffles protect internal components by deflecting damaging debris out of the airflow at the intake vents
- External brush doors - reduces service time by providing easy access to brushes
- **Includes:** Side handle, 7" and 9" type 27 guard and spanner wrench

Model No. TLZ821
Mfg. No. 6089-30
Price/Each \$314.00



SPECIFICATIONS

Wheel Diameter: 7" to 9"
Voltage: 120 V
Amperage: 15 Amp
No Load RPM: 6000
Spindle Size: 5/8"
Tool Weight: 13.7 lbs.
Trigger, Non Lock-On
Model No.: TLZ82

ANGLE GRINDERS

- Rear handle design for greater control
- Trigger lock
- Light weight for high production work with less fatigue
- **Includes:** 5" grinding wheel 24 grit and side handle

Model No. TF719
Mfg. No. 9005B
Price/Each \$156.00



SPECIFICATIONS

Wheel Diameter: 5"
Voltage: 120 V
Amperage: 10 Amp
No Load RPM: 10000
Spindle Size: 5/8"
Tool Weight: 6.6 lbs.

BENCH GRINDING WHEELS

Typical Applications

- Offhand deburring and sharpening of parts and tools



GEMINI

- Quality, grey aluminum oxide for metal general purpose applications and sharp, green silicon carbide for nonferrous applications
- Each wheel contains nested bushings, accommodates a wide variety of standard arbor sizes
- Economical prices; ideal for small job shops and numerous applications
- All wheels supplied with bushings



NORTON

Model No.	Mfg. No.	Size			Grade	Max RPM	Price /Each
		D"	x	T"	x	A"	
ALUMINUM OXIDE WHEELS FOR STEEL APPLICATION							
NS320	36132	6	x	1/2	x	1	Coarse 4140 24.20
NS321	36131	6	x	1/2	x	1	Medium 4140 24.20
NS322	36133	6	x	1/2	x	1	Fine 4140 24.20
NS323	88245	6	x	3/4	x	1	Coarse 4140 28.20
NS324	88240	6	x	3/4	x	1	Medium 4140 28.20
NS325	88235	6	x	3/4	x	1	Fine 4140 28.20
NS326	88260	6	x	1	x	1	Coarse 3600 32.60
NS327	88255	6	x	1	x	1	Medium 3600 32.60
NS328	88250	6	x	1	x	1	Fine 3600 32.60
NS329	88275	7	x	1	x	1	Coarse 3600 39.90
NS330	88270	7	x	1	x	1	Medium 3600 39.90
NS331	88265	7	x	1	x	1	Fine 3600 39.90
NS332	88278	8	x	3/4	x	1	Coarse 3600 41.50
NS333	88277	8	x	3/4	x	1	Medium 3600 41.50
NS334	42317	8	x	3/4	x	1	Fine 3600 41.50
NS335	44454	8	x	1	x	1	Very coarse 3600 48.90
NS336	88286	8	x	1	x	1	Coarse 3600 48.90
NS337	88285	8	x	1	x	1	Medium 3600 48.90
NS338	88280	8	x	1	x	1	Fine 3600 48.90
NS339	60788	10	x	1	x	1	Very coarse 2485 74.50
NS340	88295	10	x	1	x	1	Coarse 2485 74.50
NS341	88290	10	x	1	x	1	Medium 2485 74.50
NS342	60350	10	x	1	x	1	Fine 2485 74.50
NS343	61250	10	x	1 1/4	x	1 1/4	Coarse 2485 88.50
NS344	61251	10	x	1 1/4	x	1 1/4	Medium 2485 88.50
NS345	61393	10	x	1 1/2	x	1 1/4	Coarse 2485 102.00
NS346	61395	10	x	1 1/2	x	1 1/4	Medium 2485 102.00
NS347	63052	12	x	1 1/2	x	1 1/2	Coarse 2070 141.00
NS348	63053	12	x	1 1/2	x	1 1/2	Medium 2070 141.00
NS349	63054	12	x	2	x	1 1/2	Very coarse 2070 181.00
NS350	63055	12	x	2	x	1 1/2	Coarse 2070 181.00
NS351	63056	12	x	2	x	1 1/2	Medium 2070 181.00

Model No.	Mfg. No.	Size			Grade	Max RPM	Price /Each
		D"	x	T"	x	A"	
SILICON CARBIDE WHEELS FOR NON-STEEL APPLICATIONS							
NS352	36571	6	x	1/2	x	1	Medium 4140 40.50
NS353	36572	6	x	1/2	x	1	Fine 4140 40.50
NS354	36573	6	x	1/2	x	1	Extra-fine 4140 40.50
NS355	37190	6	x	3/4	x	1	Medium 4140 48.20
NS356	37191	6	x	3/4	x	1	Fine 4140 48.20
NS357	37192	6	x	3/4	x	1	Extra-fine 4140 48.20
NS358	37187	6	x	1	x	1	Medium 3600 55.80
NS359	37193	6	x	1	x	1	Fine 3600 55.80
NS360	37194	6	x	1	x	1	Extra-fine 3600 55.80
NS361	42300	7	x	1	x	1	Medium 3600 71.70
NS362	42301	7	x	1	x	1	Fine 3600 71.70
NS363	42302	7	x	1	x	1	Extra-fine 3600 71.70
NS364	44087	8	x	1	x	1	Medium 3600 83.40
NS365	44534	8	x	1	x	1	Fine 3600 83.40
NS366	44535	8	x	1	x	1	Extra-fine 3600 83.40
NS367	44536	10	x	1	x	1 1/4	Medium 2485 133.00
NS368	60366	10	x	1	x	1 1/4	Fine 2485 133.00
NS369	63359	12	x	2	x	1 1/4	Medium 2070 321.00
NS370	63360	12	x	2	x	1 1/4	Fine 2070 321.00

Arbor bushings

These size bushings shipped free of charge with your Gemini wheel order

Wheel Diameter	Wheel Centre Hole	1/2"	5/8"	3/4"	7/8"	1"	1 1/4"
6", 7"	1"	•	•	•	•		
8"	1"		•	•	•		
10"	1 1/4"			•	•	•	
12" x 1"	1 1/4"			•	•	•	
12" x 2"	1 1/4"					•	
12"	1 1/2"						•

10" BENCH GRINDERS

- 14 A, 110 V, single phase
- Wheel diameter: 10"
- 1720 RPM
- Weight: 80 lbs.
- Includes: Removable wheel covers, plastic eye shields and medium and coarse grinding wheels

Model No. TZ815
Mfg. No. KC-1090
Price/Each \$376.00



See page 386 - 406 for Eye Protection Section



D x T x A: Diameter x Thickness x Arbor Size

OFFICE PRODUCTS

INSTRUMENTS, SCALES & ELECTRICAL

SHIPPING & PACKAGING

TOOLS & EQUIPMENT

WELDING & METALWORKING

SAFETY EQUIPMENT & SUPPLIES

JANITORIAL & MAINTENANCE

MATERIAL HANDLING & STORAGE

FLAP DISCS

Typical Applications

- Stock removal
- Deburring
- Blending welds
- Edge chamfering
- Rust removal
- Cleaning and finishing

NEON R766 ALUMINUM OXIDE

- Great for difficult-to-grind material such as aluminum, brass, bronze, stainless, carbon steel and titanium
- Good-performing, economically priced, general purpose discs
- Longer life and faster cut rate
- High-strength, lightweight & absorbs vibration
- Plastic wears away as disc grinds, allowing for full use of flap
- **Type 27 flat face:** High flap density, flexible plastic back discs
- **Type 29 conical shape:** Standard flap density



Model No.	Mfg. No.	D"	Size x A"	Grit	Price /Each
TYPE 27					
N0083	66623399062	4 1/2	x 7/8	36	6.73
N0084	66623399063	4 1/2	x 7/8	40	6.73
N0085	66623399064	4 1/2	x 7/8	60	6.73
N0086	66623399212	5	x 7/8	40	6.78
N0087	66623399213	5	x 7/8	60	6.78
N0088	66623399214	5	x 7/8	80	6.78
N0089	66623399071	7	x 7/8	40	14.30
N0090	66623399072	7	x 7/8	60	14.30
N0091	66623399073	7	x 7/8	80	14.30
TYPE 29					
N0092	66623399032	4 1/2	x 7/8	36	5.61
N0093	66623399033	4 1/2	x 7/8	40	5.61
N0094	66623399034	4 1/2	x 7/8	60	5.61
N0095	66623399035	4 1/2	x 7/8	80	5.61
N0096	66623399175	4 1/2	x 7/8	120	5.61
N0097	66623399036	5	x 7/8	36	5.65
N0098	66623399037	5	x 7/8	40	5.65
N0099	66623399038	5	x 7/8	60	5.65
N0100	66623399039	5	x 7/8	80	5.65
N0101	66623399181	5	x 7/8	120	5.65
N0102	66623399187	7	x 7/8	36	11.90
N0103	66623399046	7	x 7/8	40	11.90
N0104	66623399047	7	x 7/8	60	11.90
N0105	66623399048	7	x 7/8	80	11.90
N0106	66623399188	7	x 7/8	120	11.90

747D (CERAMIC ALUMINUM OXIDE - TYPE 27)

- Premium ceramic mineral provides exceptional cut and life on the hardest metals



Model No.	Mfg. No.	D"	Size x A"	Grit	Max RPM	Price /Each
BZ778	49613	4 1/2	x 7/8	36	13 300	5.73
BZ779	49614	4 1/2	x 7/8	50	13 300	5.73
BZ780	49615	4 1/2	x 7/8	60	13 300	5.73
BZ781	49616	4 1/2	x 7/8	80	13 300	5.73
BZ782	49617	4 1/2	x 7/8	120	13 300	5.73

D x A: Diameter x Arbor Size

QUICK TRIM SG BLAZE R980P - TYPE 27

- Latest-generation ceramic alumina abrasive grain and improved supersize grinding aid
- New orange, plastic back plate material
- Easily trimmable, the plastic wears away as the flap discs grind
- Durable Y-wt polyester flaps significantly improve life, grain retention, and fray resistance
- 1-step grinding and finishing
- Ideal for: Stock removal, edge chamfering, weld blending, deburring/deflashing, cleaning/finishing
- Best/highest productivity on stainless steel, titanium, and super alloys



Model No.	Mfg. No.	D"	Size x A"	Grit	Max RPM	Price /Each
NR954	66254400253	4 1/2	x 7/8	40	13 300	8.46
NR955	66254400254	4 1/2	x 7/8	60	13 300	8.46
NR956	66254400255	4 1/2	x 7/8	80	13 300	8.46
NR957	66254400256	4 1/2	x 7/8	120	13 300	8.46
NR958	66254400262	5	x 7/8	40	12 000	10.60
NR959	66254400264	5	x 7/8	60	12 000	10.60
NR960	66254400265	5	x 7/8	80	12 000	10.60
NR961	66254400519	5	x 7/8	120	12 000	10.60
NR966	66254461059	7	x 7/8	40	8600	16.30
NR967	66254461060	7	x 7/8	60	8600	16.30
NR968	66254461061	7	x 7/8	80	8600	16.30
NR969	66254461063	7	x 7/8	120	8600	16.30
NR950	66254400257	4 1/2	x 5/8-11	40	13 300	10.50
NR951	66254400258	4 1/2	x 5/8-11	60	13 300	10.50
NR952	66254400259	4 1/2	x 5/8-11	80	13 300	10.50
NR953	66254400261	4 1/2	x 5/8-11	120	13 300	10.50
NR962	66254461066	7	x 5/8-11	40	8600	20.40
NR963	66254461067	7	x 5/8-11	60	8600	20.40
NR964	66254461068	7	x 5/8-11	80	8600	20.40
NR965	66254461069	7	x 5/8-11	120	8600	20.40

CUBITRON™ II 967A

- Ideal for a wide range of low to medium-high pressure applications
- Used for paint prep and stainless steel fabrication where finish and gouge resistance are important
- Safe on stainless steel, carbon steel, aluminum and non-ferrous metals
- Grinding aid helps keep product cool on heat-sensitive metals
- All discs have Y-weight poly-cotton backing



Model No.	Mfg. No.	D"	Size x A"	Grit	Max RPM	Price /Each
TYPE 27						
NU325	051141-55605	4 1/2	x 7/8	40+	13 300	6.33
NU326	051141-55606	4 1/2	x 7/8	60+	13 300	6.33
NU327	051141-55607	4 1/2	x 7/8	80+	13 300	6.33
NU345	051125-86715	5	x 7/8	40+	12 000	6.97
NU348	051125-86718	5	x 7/8	60+	12 000	6.97
NU349	051125-86719	5	x 7/8	80+	12 000	6.97
NU328	051141-55611	7	x 7/8	40+	8600	10.80
NU329	051141-55612	7	x 7/8	60+	8600	10.80
NU330	051141-55613	7	x 7/8	80+	8600	10.80
TYPE 29						
NU331	051141-55623	4 1/2	x 7/8	40+	13 300	6.33
NU332	051141-55624	4 1/2	x 7/8	60+	13 300	6.33
NU333	051141-55625	4 1/2	x 7/8	80+	13 300	6.33
NU346	051125-86716	5	x 7/8	40+	12 000	6.97
NU347	051125-86717	5	x 7/8	60+	12 000	6.97
NU350	051125-86720	5	x 7/8	80+	12 000	6.97
NU334	051141-55629	7	x 7/8	40+	8600	10.80
NU335	051141-55630	7	x 7/8	60+	8600	10.80
NU336	051141-55631	7	x 7/8	80+	8600	10.80

NORTON METAL R828

- Quality zirconia alumina abrasive
- Strong engineered blend of X-wt cotton and Y-weight dark blue polyester flaps offers higher cut rate, longer life, and greater wear resistance
- Durable, fibreglass back offers strength, lightweight and absorbs vibration
- Available in both Type 29 conical for hard-to-grind materials and Type 27 flat for softer materials

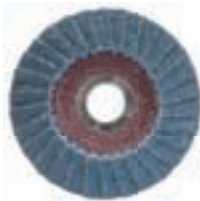

PREMIUM 2 IN 1 – TYPE 29

- Grinding & finishing in just 1 step
- Offers high removal and an aggressive angle
- Superior combination of life & removal with a trimmable backing
- Lowers your blending & finishing costs
- For use on steel & stainless steel
- Material: Zirconium



Model No.	Mfg. No.	D"	Size x A"	Grit	Max RPM	Price /Each
NU413	34043471	4 1/2	x 7/8	40	13 300	6.32
NU414	34043472	4 1/2	x 7/8	60	13 300	6.32
NU415	34043473	4 1/2	x 7/8	80	13 300	6.32
NU416	34043475	5	x 7/8	40	12 250	7.91
NU417	34043476	5	x 7/8	60	12 250	7.91
NU418	34043477	5	x 7/8	80	12 250	7.91

STANDARD 2 IN 1 – TYPE 29

- Standard aggressive fiber backed Zirconium
- High removal rate
- For use on steel & stainless steel
- Material: Zirconium



Model No.	Mfg. No.	D"	Size x A"	Grit	Max RPM	Price /Each
NU423	572473	4 1/2	x 7/8	40	13 300	3.96
NU424	454393	4 1/2	x 7/8	60	13 300	3.96
NU425	455312	4 1/2	x 7/8	80	13 300	3.96
NU426	824385	5	x 7/8	40	12 250	4.65
NU427	455303	5	x 7/8	60	12 250	4.65
NU428	458587	5	x 7/8	80	12 250	4.65



Model No.	Mfg. No.	D"	Size x A"	Grit	Max RPM	Price /Each
NORTON METAL TYPE 27 - FIBREGLASS PLATE						
NR884	66254472653	4 1/2	x 7/8	36	13 300	4.53
NR885	66254437004	4 1/2	x 7/8	40	13 300	4.53
NR886	66254448989	4 1/2	x 7/8	60	13 300	4.53
NR887	66254448990	4 1/2	x 7/8	80	13 300	4.53
NR888	66254472659	5	x 7/8	36	12 000	4.59
NR889	66254472660	5	x 7/8	40	12 000	4.59
NR890	66254472661	5	x 7/8	60	12 000	4.59
NR891	66254472662	5	x 7/8	80	12 000	4.59
NR892	66254472664	7	x 7/8	36	8600	9.69
NR893	66254472665	7	x 7/8	40	8600	9.69
NR894	66254472666	7	x 7/8	60	8600	9.69
NR895	66254472667	7	x 7/8	80	8600	9.69

Model No.	Mfg. No.	D"	Size x A"	Grit	Max RPM	Price /Each
NORTON METAL TYPE 29 - FIBREGLASS PLATE						
NR148	66254419963	4 1/2	x 7/8	36	13 300	4.53
NR149	66254419978	4 1/2	x 7/8	40	13 300	4.53
NR150	66254419984	4 1/2	x 7/8	60	13 300	4.53
NR151	66254419987	4 1/2	x 7/8	80	13 300	4.53
NR152	66254419998	5	x 7/8	36	12 000	4.66
NR153	66254420001	5	x 7/8	40	12 000	4.66
NR154	66254420002	5	x 7/8	60	12 000	4.66
NR155	66254420003	5	x 7/8	80	12 000	4.66
NR156	66254420004	7	x 7/8	36	8600	9.79
NR157	66254420006	7	x 7/8	40	8600	9.79
NR158	66254420007	7	x 7/8	60	8600	9.79
NR159	66254420008	7	x 7/8	80	8600	11.70

FLAP WHEELS

Typical Applications

- Metal fabrication
- Blending welds
- Deburring
- Cleaning and finishing

Conformable to most shapes

Designed to deliver a consistent finish with a uniform rate of cut, Norton flap wheels wear away, continually exposing fresh abrasive. Conformable to most shapes, they are available in coarse to fine grit.

244E FLAP WHEELS

ALUMINUM OXIDE - XE WT. CLOTH

- General purpose flap wheel delivers consistent finish and uniform cut
- Can be shaped to fit any desired contour



BENCH MOUNTED FLAP WHEELS

- General purpose flap wheel delivers consistent finish and uniform cut
- Can be shaped to fit any desired contour



244E/241E FLAP WHEELS

Model No.	Size			Grit	Max RPM	Price /Each
	D"	T"	A"			
BP595	6	1	1	50	6100	28.20
BP596	6	1	1	60	6100	31.90
BP597	6	1	1	80	6100	34.00
BP592	6	1	1	120	6100	33.40
BP594	6	1	1	220	6100	39.30
BP600	6	2	1	60	5200	48.38
BP599	6	2	1	150	5200	58.50



Model No.	Size			Grit	Max RPM	Price /Each
	D"	T"	A"			
BP577	1	1	1/4	60	25 000	6.23
BP578	1	1	1/4	80	25 000	6.23
BP576	1	1	1/4	120	25 000	6.23
BP580	2	1	1/4	60	20 000	8.78
BP581	2	1	1/4	80	20 000	8.30

D x A: Diameter x Arbor Size

OFFICE PRODUCTS

INSTRUMENTS, SCALES & ELECTRICAL

SHIPPING & PACKAGING

TOOLS & EQUIPMENT

WELDING & METALWORKING

SAFETY EQUIPMENT & SUPPLIES

JANITORIAL & MAINTENANCE

MATERIAL HANDLING & STORAGE

ABRASIVES



MANDREL MOUNTED FLAP WHEELS

- Mandrel mounted high performance
- Designed with the 1/4" mandrel as a integral part of the wheel
- More aggressive and works great in heavy stock removal operations
- A very durable, long lasting mini flap wheel

MERIT

Model No.	Size D" x T" x S"	Grit	Max RPM	Price /Each
BQ700	1 x 5/8 x 1/4	40	30000	5.20
BQ696	1 x 5/8 x 1/4	60	30000	5.20
BQ697	1 x 5/8 x 1/4	80	30000	5.20
BQ698	1 x 5/8 x 1/4	120	30000	5.20
BQ571	1 x 5/8 x 1/4	180	30000	5.20
BQ699	1 x 5/8 x 1/4	240	30000	5.20
BQ747	1 x 5/8 x 1/4	320	30000	5.20
BQ567	1 x 1 x 1/4	40	30000	5.51
NP722	1 x 1 x 1/4	50	30000	5.51
BQ730	1 x 1 x 1/4	60	30000	5.51
BQ731	1 x 1 x 1/4	80	30000	5.51
BQ732	1 x 1 x 1/4	120	30000	5.51
BQ733	1 x 1 x 1/4	180	30000	5.51
BQ701	1 x 1 x 1/4	240	30000	5.51
BQ734	1 x 1 x 1/4	320	30000	5.51
BQ736	1 3/8 x 5/8 x 1/4	60	30000	5.20
BQ737	1 3/8 x 5/8 x 1/4	80	30000	5.20
BQ738	1 3/8 x 5/8 x 1/4	120	30000	5.20
BQ739	1 3/8 x 5/8 x 1/4	180	30000	5.20
BQ740	1 3/8 x 5/8 x 1/4	240	30000	5.20
BQ677	1 1/2 x 1 x 1/4	40	25000	6.96
BQ741	1 1/2 x 1 x 1/4	60	25000	6.96
BQ707	1 1/2 x 1 x 1/4	80	25000	6.96
BQ708	1 1/2 x 1 x 1/4	120	25000	6.96
BQ742	1 1/2 x 1 x 1/4	180	25000	6.96
BQ613	1 1/2 x 1 x 1/4	240	25000	6.96
BQ709	1 1/2 x 1 x 1/4	320	25000	6.96

D x T x S: Diameter x Thickness x Shank

BENCH MOUNTED FLAP WHEELS

- Mounted on bench grinder applies light scratch pattern to stainless steel

MERIT

Model No.	Size D" x T" x A"	Grit	Max RPM	Price /Each
BQ268	5 x 1 1/2 x 5/8	40	12000	31.10
BQ269	5 x 1 1/2 x 5/8	50	12000	31.10
BQ270	5 x 1 1/2 x 5/8	60	12000	31.90
BQ271	5 x 1 1/2 x 5/8	80	12000	34.00
BQ272	5 x 1 1/2 x 5/8	120	12000	36.90
BQ274	5 x 1 1/2 x 5/8	180	12000	40.30
BQ275	5 x 1 1/2 x 5/8	240	12000	40.30
BQ276	5 x 1 1/2 x 5/8	320	12000	40.30
BQ302	6 x 1/2 x 1	40	6000	28.30
BQ303	6 x 1/2 x 1	60	6000	29.00
BQ304	6 x 1/2 x 1	80	6000	31.00
BQ305	6 x 1/2 x 1	120	6000	33.60
BQ280	6 x 1/2 x 1	150	6000	35.80
BQ306	6 x 1/2 x 1	180	6000	36.70
BQ307	6 x 1/2 x 1	240	6000	36.70
BQ279	6 x 1/2 x 1	320	6000	36.70
BQ308	6 x 1 x 1	40	6000	34.50
BQ309	6 x 1 x 1	50	6000	34.50
BQ310	6 x 1 x 1	60	6000	35.40
BQ311	6 x 1 x 1	80	6000	37.80
BQ312	6 x 1 x 1	120	6000	41.00
BQ313	6 x 1 x 1	150	6000	43.60
BQ314	6 x 1 x 1	180	6000	44.80
BQ315	6 x 1 x 1	240	6000	44.80
BQ316	6 x 1 x 1	320	6000	44.80

D x T x A: Diameter x Thickness x Arbor Size



Model No.	Size D" x T" x S"	Grit	Max RPM	Price /Each
BQ710	2 x 3/4 x 1/4	40	25000	7.82
BQ711	2 x 3/4 x 1/4	60	25000	7.82
BQ712	2 x 3/4 x 1/4	80	25000	7.82
BQ713	2 x 3/4 x 1/4	120	25000	7.82
BQ714	2 x 3/4 x 1/4	180	25000	7.82
BQ754	2 x 1 x 1/4	40	25000	8.83
NP723	2 x 1 x 1/4	50	25000	8.83
BQ748	2 x 1 x 1/4	60	25000	8.83
BQ749	2 x 1 x 1/4	80	25000	8.83
BQ750	2 x 1 x 1/4	120	25000	8.83
BQ751	2 x 1 x 1/4	180	25000	8.83
BQ752	2 x 1 x 1/4	240	25000	8.83
BQ753	2 x 1 x 1/4	320	25000	8.83
BQ716	2 x 1 1/2 x 1/4	40	25000	10.10
BQ755	2 x 1 1/2 x 1/4	60	25000	10.10
BQ756	2 x 1 1/2 x 1/4	80	25000	10.10
BQ757	2 x 1 1/2 x 1/4	120	25000	10.10
BQ759	2 x 1 1/2 x 1/4	240	25000	10.10
BQ760	2 1/2 x 1 x 1/4	40	20000	9.96
BQ761	2 1/2 x 1 x 1/4	60	20000	9.96
BQ762	2 1/2 x 1 x 1/4	80	20000	9.96
BQ763	2 1/2 x 1 x 1/4	120	20000	9.96
BQ764	2 1/2 x 1 x 1/4	180	20000	9.96
BQ847	2 1/2 x 1 x 1/4	240	20000	9.96
BQ765	2 1/2 x 1 x 1/4	320	20000	9.96

Model No.	Size D" x T" x S"	Grit	Max RPM	Price /Each
BQ766	2 1/2 x 1 1/2 x 1/4	60	20000	11.40
BQ767	2 1/2 x 1 1/2 x 1/4	80	20000	11.40
BQ768	2 1/2 x 1 1/2 x 1/4	120	20000	11.40
BQ770	3 x 3/4 x 1/4	60	20000	9.96
BQ771	3 x 3/4 x 1/4	80	20000	9.96
BQ775	3 x 1 x 1/4	40	20000	10.90
BQ773	3 x 1 x 1/4	60	20000	10.90
BQ774	3 x 1 x 1/4	80	20000	10.90
BQ722	3 x 1 x 1/4	120	20000	10.90
BQ723	3 x 1 x 1/4	180	20000	10.90
BQ685	3 x 1 x 1/4	240	20000	10.90
BQ686	3 x 1 x 1/4	320	20000	10.90
BQ776	3 x 2 x 1/4	40	12000	18.90
BQ724	3 x 2 x 1/4	60	12000	18.90
BQ725	3 x 2 x 1/4	80	12000	18.90
BQ726	3 x 2 x 1/4	120	12000	18.90
BQ727	3 x 2 x 1/4	180	12000	18.90



Model No.	Size D" x T" x A"	Grit	Max RPM	Price /Each
BQ317	6 x 1 1/2 x 1	40	6000	38.80
BQ318	6 x 1 1/2 x 1	50	6000	38.80
BQ319	6 x 1 1/2 x 1	60	6000	39.80
BQ320	6 x 1 1/2 x 1	80	6000	42.50
BQ321	6 x 1 1/2 x 1	120	6000	46.00
BQ322	6 x 1 1/2 x 1	150	6000	49.00
BQ323	6 x 1 1/2 x 1	180	6000	50.40
BQ324	6 x 1 1/2 x 1	240	6000	50.40
BQ325	6 x 1 1/2 x 1	320	6000	50.40
BQ328	6 x 2 x 1	60	6000	59.30
BQ329	6 x 2 x 1	80	6000	62.90
BQ330	6 x 2 x 1	120	6000	68.80
BQ332	6 x 2 x 1	180	6000	75.10
BQ333	6 x 2 x 1	240	6000	75.10
BQ334	6 x 2 x 1	320	6000	75.10
BQ335	6 x 3 x 1	40	6000	83.50
BQ336	6 x 3 x 1	50	6000	83.50
BQ337	6 x 3 x 1	60	6000	86.10
BQ338	6 x 3 x 1	80	6000	91.50
BQ339	6 x 3 x 1	120	6000	100.00
BQ299	6 x 3 x 1	150	6000	110.00
BQ340	6 x 3 x 1	180	6000	115.00
BQ341	6 x 3 x 1	240	6000	115.00
BQ294	6 x 3 x 1	320	6000	115.00

Model No.	Size D" x T" x A"	Grit	Max RPM	Price /Each
BQ342	8 x 1 x 1	40	4500	62.60
BQ343	8 x 1 x 1	50	4500	62.60
BQ344	8 x 1 x 1	60	4500	64.10
BQ345	8 x 1 x 1	80	4500	69.00
BQ346	8 x 1 x 1	120	4500	75.50
BQ347	8 x 1 x 1	180	4500	81.40
BQ348	8 x 1 x 1	240	4500	81.40
BQ349	8 x 1 x 1	320	4500	81.40
BQ350	8 x 2 x 1	40	4500	95.00
BQ351	8 x 2 x 1	50	4500	95.00
BQ353	8 x 2 x 1	80	4500	102.00
BQ355	8 x 2 x 1	180	4500	127.00
BQ356	8 x 2 x 1	240	4500	130.00
BQ357	8 x 2 x 1	320	4500	130.00
BQ281	10 x 1 x 1 3/4	40	4000	95.20
BQ360	10 x 1 x 1 3/4	80	4000	107.00
BQ361	10 x 1 x 1 3/4	120	4000	119.00
BQ362	10 x 1 x 1 3/4	150	4000	130.00
BQ363	10 x 1 x 1 3/4	180	4000	133.00
BQ364	10 x 1 x 1 3/4	320	4000	133.00

BRISTLE DISCS

Bristle discs are ideal for safely cleaning and stripping a wide variety of substances off of metal. The discs will easily cut through hardened enamel, paint, thick dried adhesives, and layers of corrosion, without destroying the underlying material or compromising safety with dangerous flying wires.

In addition, bristle discs do not clog up with substances being removed, and give consistent finishes throughout the life of the discs.

All bristle discs are colour coded by grade and are made of nylon embedded with abrasive to create an abrasive action. Each disc is flexible and easily conforms to contours and tight corners and angles.

ROLOC™ BRISTLE DISCS

- Uniform concentration of mineral throughout the flexible abrasive filled bristles
- Fast cut rate and long performance life for removal of rust, coatings, and flashing
- Roloc™ attachment method for quick and easy disc changes
- All discs feature a 5/8" trim length and are embedded with Regalite™ abrasive mineral



Model No.	Size"	Trim Type	Grit	Colour	Max. RPM	Price /Each
BP106	1	Straight	50	Green	30 000	5.08
BP107	1	Straight	80	Yellow	30 000	5.08
BP105	1	Straight	120	White	30 000	5.08
BP109	2	Tapered	50	Green	25 000	8.18
BP110	2	Tapered	80	Yellow	25 000	8.18
BP108	2	Tapered	120	White	25 000	8.18
BP112	3	Tapered	50	Green	18 000	12.10
BP113	3	Tapered	80	Yellow	18 000	12.10
BP111	3	Tapered	120	White	18 000	12.10

ROLOC™ RADIAL BRISTLE DISCS

- Same characteristics as the Roloc™ bristle discs, but in a radial format
- Roloc™ radial bristle discs come in 3" diameters and have a maximum operating RPM of 25 000



Model No.	Grit	Colour	Price /Each
BP103	50	Green	8.83
BP104	80	Yellow	8.83
BP102	120	White	8.83

ROLOC™ DISC HOLDERS

- Rubber Roloc™ back-up pads are offered in different sizes and degrees of hardness for varying grinding applications
- All Roloc™ disc holders are threaded and require model BP013 1/4", threaded shaft



Model No.	Size"	Density	Max. RPM	Price /Each
BP007	1	Medium	30 000	16.20
BP011	2	Soft	20 000	19.50
BP008	2	Medium	25 000	21.30
BP005	2	Hard	25 000	19.50
BP003	2	Extra hard	25 000	23.60
BP012	3	Soft	15 000	23.80
BP009	3	Medium	18 000	23.80
BP006	3	Hard	20 000	23.80
BP004	3	Extra hard	20 000	26.20
BP010	4	Medium	12 000	26.20

ROLOC™ THREADED SHAFT

Model No. BP013 Price/Each \$3.77

RADIAL BRISTLE DISCS

- All discs are very flexible for deburring, cleaning, or finishing intricate or tiny areas
- Ideal for hi-tech housings and components, medical products, cleaning marks off of precision parts and creating satin, and higher, finishes on hard and soft metals



Priced per Package

Model No.	Size"	Shank"	Grit	Colour	Max. RPM	Qty /Pkg.	Price /Each
BP096	9/16	1/16	120X	White	30 000	48	54.40
BP097	9/16	1/16	P220X	Red	30 000	48	54.40
BP098	9/16	1/16	P400X	Blue	30 000	48	51.70
BP101	9/16	1/16	Pumice	Pink	30 000	192	207.00
BP100	9/16	1/16	Polish II	Peach	30 000	48	54.40
BP099	9/16	1/16	Polish I	Light Green	30 000	48	51.70
BP091	3/4	1/16	80X	Yellow	30 000	48	59.20
BP089	3/4	1/16	P220X	Red	30 000	48	59.20
BP090	3/4	1/16	P400X	Blue	30 000	192	237.00
BP092	3/4	1/16	Pumice	Pink	30 000	48	59.20
BP083	1	1/8	36X	Dark Brown	30 000	24	33.60
BP084	1	1/8	50X	Green	30 000	24	33.80
BP085	1	1/8	80X	Yellow	30 000	24	33.60
BP082	1	1/8	120X	White	30 000	24	33.60
BP087	3	3/8	50	Green	25 000	10	88.30
BP088	3	3/8	80	Yellow	25 000	10	88.30

RADIAL BRISTLE BRUSHES FOR BENCH GRINDERS

- Radial bristle brushes have the same characteristics as the other 3M bristle brushes, but come in a convenient 6" size bench grinders
- Each brush comes with its own adapter
- Radial bristle brushes take the place of conventional wire wheels, on bench grinders, for general maintenance and production work
- Nylon bristles eliminate dangerous flying wires

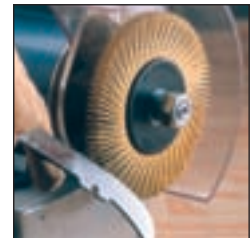

Model No.	Size"	Grit	Colour	Max. RPM	Price /Each
BP093	6	36X	Dark brown	10 000	49.30
BP094	6	50X	Green	10 000	49.30
BP095	6	80X	Yellow	10 000	49.30

RADIAL BRISTLE DISCS FOR RIGHT ANGLE GRINDERS

- 4 1/2" bristle discs with 5/8"-11 threaded hub
- Same safety and efficiency benefits as other bristle discs but in a right angle grinder configuration
- Ideal for cleaning, delaminating, removing rust and oxidation, and deburring a variety of hard and soft metals and plastics
- All discs have a maximum operating speed of 12 000 RPM



Model No.	Size"	Grit	Colour	Price /Each
VV392	4 1/2	36	Brown	31.30
BP079	4 1/2	50	Green	31.30
BP080	4 1/2	80	Yellow	31.30
BP078	4 1/2	120	White	31.30

ABRASIVES



FIBRE DISCS

Typical Applications

- Material removal
- Weld grinding and blending
- Light deburring and finishing

ZIRCONIA ALUMINA FIBRE DISCS

- Durable zirconia alumina abrasive with a heavy fibre backing
- Superior product for heavy weld and metal grinding
- Cool grinding action that reduces glazing and loading
- Excellent for stainless steel applications



MERIT CERAMIC DISCS

- High performance ceramic alumina abrasive on heavy fibre backing
- Economical choice for heavy stock removal



MERIT

Model No.	Mfg. No.	Size		Grit	Price /Each
		D"	A"		
BZ560	66623353315	4 1/2	7/8	24	1.64
BZ561	66623353316	4 1/2	7/8	36	1.56
BZ562	66623353318	4 1/2	7/8	50	1.52
BZ563	66623353319	4 1/2	7/8	60	1.39
BZ564	66623353320	4 1/2	7/8	80	1.27
BZ577	66623357290	5	7/8	24	1.98
BZ579	66623357292	5	7/8	50	1.64
BZ580	66623357293	5	7/8	60	1.52
BZ581	66623357294	5	7/8	80	1.45
BZ582	66623357295	7	7/8	24	2.85
BZ583	66623357296	7	7/8	36	2.85
BZ584	66623357297	7	7/8	50	2.64
BZ585	66623357298	7	7/8	60	2.83
BZ586	66623357299	7	7/8	80	2.76

MERIT

Model No.	Mfg. No.	Size		Grit	Price /Each
		D"	A"		
BZ573	66623355601	4 1/2	7/8	24	2.18
BZ574	66623355602	4 1/2	7/8	36	2.10
BZ575	66623355603	4 1/2	7/8	50	2.00
BZ576	66623355604	4 1/2	7/8	60	1.79
NS489	66623365598	4 1/2	7/8	80	1.54
BZ569	66623355597	5	7/8	24	2.58
BZ570	66623355598	5	7/8	36	2.37
BZ571	66623355599	5	7/8	50	2.18
BZ572	66623355600	5	7/8	60	1.93
NS494	66623366015	5	7/8	80	1.77
BZ565	66623355578	7	7/8	24	4.09
BZ566	66623355594	7	7/8	36	3.97
BZ567	66623355595	7	7/8	50	3.80
BZ568	66623355596	7	7/8	60	3.70
NS499	66623365600	7	7/8	80	3.20

NORTON METAL F240 DISCS

- Quality aluminum oxide grain on heavy fibre backing
- Good for small job around the shop and general purpose applications



NORTON

Model No.	Mfg. No.	Size		Grit	Price /Each
		D"	A"		
BQ035	66623353309	4 1/2	7/8	24	1.00
BQ036	66623353306	4 1/2	7/8	36	0.94
BQ037	66623353310	4 1/2	7/8	50	0.81
BQ038	66623353311	4 1/2	7/8	60	0.75
BQ039	66623353312	4 1/2	7/8	80	0.69
BQ040	66623353313	4 1/2	7/8	100	0.66
BQ041	66623353314	4 1/2	7/8	120	0.66
BQ042	66623357276	5	7/8	24	1.12
BQ043	66623357277	5	7/8	36	1.02
BQ044	66623357278	5	7/8	50	0.98
BQ045	66623357279	5	7/8	60	0.87
BQ046	66623357280	5	7/8	80	0.83
BQ047	66623357281	5	7/8	100	0.83
BQ048	66623357282	5	7/8	120	0.81
BQ049	66623357283	7	7/8	24	1.60
BQ050	66623357284	7	7/8	36	1.54
BQ051	66623357285	7	7/8	50	1.45
BQ052	66623357286	7	7/8	60	1.35
BQ053	66623357287	7	7/8	80	1.31
BQ054	66623357288	7	7/8	100	1.25
BQ055	66623357289	7	7/8	120	1.23

AIR COOLED RUBBER BACK UP PADS

- Designed for medium to heavy grinding applications
- Slotted aluminum hub design draws cool air behind the disc
- Curved ribs on the rubber face force heat away from the disc and back-up pad
- Cooler cutting action reduces disc loading and increases grinding life
- All pads have 5/8"-11 threaded female hub for mounting



Model No.	Mfg. No.	Description	Max RPM	Price /Each
BZ056	08834195006	4 1/2" back up pad	11 000	37.30
BZ053	08834195002	5" back up pad	10 000	38.30
BZ054	08834195003	7" back up pad	8500	57.70
BZ052	08834195000	Disc pad nut 5/8"-11	-	8.06
BY731	08834192776	Spanner wrench fits 5/8" and 3/8"	-	20.90

See pages
446 - 453 for
Particulate
Respirators



D x A: Diameter x Arbor Size

785C REGALITE™ POLYCUT™ FIBRE DISCS

- 3M Cubitron™ abrasive grain disc constructed on a fibre backing
- Resin bonded for heat resistance
- Features grinding aid for cooler grinding
- Used primarily for stainless steel grinding and blending



381C ALUMINUM OXIDE FIBRE DISCS

- General purpose disc for weld removal, grinding and blending
- Aluminum oxide
- Resin bonded for heat resistance



Model No.	Size			Grit	Price /Each
	D"	x	A"		
BP290	4 1/2	x	7/8	36	3.07
BP294	4 1/2	x	7/8	50	2.87
BP298	4 1/2	x	7/8	60	2.87
BP302	4 1/2	x	7/8	80	2.57
BP281	4 1/2	x	7/8	100	2.57
BP285	4 1/2	x	7/8	120	2.57
BP291	5	x	7/8	36	3.13
BP295	5	x	7/8	50	2.93
BP299	5	x	7/8	60	2.93
BB425	5	x	7/8	80	2.62
BP282	5	x	7/8	100	2.62
BP286	5	x	7/8	120	2.62
BP292	7	x	7/8	36	3.97
BP296	7	x	7/8	50	3.70
BP300	7	x	7/8	60	3.52
BP283	7	x	7/8	100	3.32
BP287	7	x	7/8	120	3.14

Model No.	Size			Grit	Price /Each
	D"	x	A"		
BP228	4 1/2	x	7/8	24	2.65
BP232	4 1/2	x	7/8	36	2.65
BP240	4 1/2	x	7/8	60	2.47
BP244	4 1/2	x	7/8	80	2.22
BP230	5	x	7/8	24	2.70
BP234	5	x	7/8	36	2.70
BP242	5	x	7/8	60	2.53
BP246	5	x	7/8	80	2.25
BP231	7	x	7/8	24	3.42
BP243	7	x	7/8	60	3.18
BP247	7	x	7/8	80	3.18

ACCESSORIES

- **Disc Pad Hubs:** Plastic hubs with 5/8"-11 metal insert; use with 3M disc pad face plates
- **Disc Retainer Nuts:** For use with all 3M disc pad face plates, disc pads and 3M disc pad hubs; nuts have 5/8"-11 threaded arbor hole in three depths to accommodate grinder shaft lengths
- **Disc Pad Face Plates:** Backup plates for fibre discs 3M disc pad face plates are colour coded by density; ribbed plates result in cooler running discs; use harder face plates for heavier stock removal applications



Model No.	Size"	Price/Each
DISC PAD HUBS		
BP212	2 1/2	53.20
BP213	4 1/2	53.70
DISC RETAINER NUTS		
BP219	5/8	21.90
BP217	1/2	21.90
BP218	3/8	21.90



DISC PAD FACE PLATES

Model No.	Size"	Max. RPM	Hardness - Colour	Price /Each
NS715	4 1/2	13 300	Medium - Grey	24.50
NS716	4 1/2	13 300	Hard - Black	24.70
BP188	5	12 000	Medium - Grey	32.80
BP187	5	12 000	Hard - Black	32.80
BP190	5	12 000	Extra Hard - Red	32.80
BP192	7	8 600	Medium - Grey	47.50
BP191	7	8 600	Hard - Black	47.50
BP194	7	8 600	Extra Hard - Red	47.50

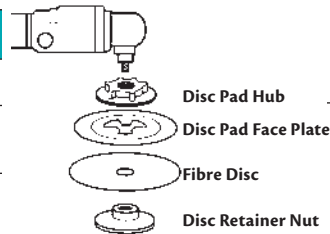

501C ALUMINA ZIRCONIA FIBRE DISCS

- Premium mineral for fast, cool grinding on all metals



Model No.	Size			Grit	Price /Each
	D"	x	A"		
BP419	4 1/2	x	7/8	24	1.28
BP422	4 1/2	x	7/8	36	1.28
BP425	4 1/2	x	7/8	50	1.28
BP428	4 1/2	x	7/8	60	1.15
BP431	4 1/2	x	7/8	80	1.15
BP306	4 1/2	x	7/8	100	1.15
BP307	4 1/2	x	7/8	120	1.28
BP420	5	x	7/8	24	1.28
BP423	5	x	7/8	36	1.28
BP426	5	x	7/8	50	1.28
BP429	5	x	7/8	60	1.28
BP432	5	x	7/8	80	1.28
BP415	5	x	7/8	100	1.28
BP417	5	x	7/8	120	1.20
BP421	7	x	7/8	24	3.22
BP424	7	x	7/8	36	3.17
BP427	7	x	7/8	50	2.97
BP430	7	x	7/8	60	2.47
BP433	7	x	7/8	80	2.60
BP418	7	x	7/8	120	2.60

D x A: Diameter x Arbor Size

OFFICE
PRODUCTS

INSTRUMENTS,
SCALES &
ELECTRICAL

SHIPPING &
PACKAGING

TOOLS &
EQUIPMENT

WELDING &
METALWORKING

SAFETY
EQUIPMENT
& SUPPLIES

JANITORIAL &
MAINTENANCE

MATERIAL
HANDLING &
STORAGE

ABRASIVES



SPEED-LOK TS & TR DISCS

Typical Applications

- Light to medium pressure grinding
- Blending, levelling and finishing applications
- For use on contours or flat surfaces

Features & benefits

Speed-Lok fastener, allows quick, tool-free disc changes allow for more grinding time
Twist on and twist off in 2 1/2 turns, disc locks securely to back-up pad, but is easily removed

NORTON SG BLAZE R980P CLOTH DISCS

- SG ceramic grain, provides coolest cut and significantly faster cut rates
- Improved resin bond system and durable backing offers greater durability and longest life on tough applications and stainless steel, and edge-fray resistance
- Polyester Y-wt backing, 3-ply laminate discs (yellow backing) more aggressive; ideal when durability and long life are required



NORTON

Size"	Grit	TS (Type II) Discs			TR (Type III) Discs		
		Model No.	Mfg. No.	Price /Each	Model No.	Mfg. No.	Price /Each
1 1/2	36	NS547	66261162307	1.31	NS559	66261162308	1.31
1 1/2	50	NS548	66261162309	1.21	NS560	66261162310	1.21
1 1/2	60	NS549	66261162311	1.18	NS561	66261162312	1.18
1 1/2	80	NS550	66261162313	1.18	NS562	66261162314	1.18
2	36	NS551	66261162317	1.87	NS563	66261162318	1.87
2	50	NS552	66261162319	1.83	NS564	66261162320	1.83
2	60	NS553	66261162321	1.72	NS565	66261162322	1.72
2	80	NS554	66261162323	1.72	NS566	66261162324	1.72
3	36	NS555	66261162327	2.51	NS567	66261162328	2.51
3	50	NS556	66261162329	2.33	NS568	66261162330	2.33
3	60	NS557	66261162331	2.24	NS569	66261162332	2.24
3	80	NS558	66261162333	2.24	NS570	66261162334	2.24

MERIT ZIRC PLUS R801 CLOTH DISCS

- Self-sharpening, zirconia alumina abrasive, cooler cut, longer life
- Heavy Y-wt backing, two-ply construction, extended durability and reduced edge-wear
- For grinding and deburring stainless steel



MERIT

Size"	Grit	TS (Type II) Discs			TR (Type III) Discs		
		Model No.	Mfg. No.	Price /Each	Model No.	Mfg. No.	Price /Each
1 1/2	36	BR815	08834167058	0.94	-	-	-
1 1/2	50	BR817	08834167060	0.87	-	-	-
1 1/2	60	BR818	08834167061	0.87	BR842	08834167103	0.87
1 1/2	80	BR819	08834167062	0.87	BR843	08834167104	0.87
2	36	BQ023	08834167065	1.45	BR845	08834167107	1.45
2	50	BQ025	08834165583	1.35	BR847	08834167109	1.35
2	60	BQ026	08834167068	1.25	BR848	08834167110	1.25
2	80	BQ027	08834167069	1.25	BR849	08834167111	1.25
3	36	BQ029	08834167072	1.97	BR851	08834167114	1.97
3	50	BQ031	08834167074	1.89	BR853	08834167116	1.89
3	60	BQ032	08834167075	1.79	BR854	08834167117	1.79
3	80	BQ033	08834167076	1.73	BR855	08834167118	1.73

MERIT ALO RESIN BOND CLOTH DISCS

- Premium aluminum oxide abrasive
- Long life
- Heavy-weight cloth construction
- Excellent durability
- X-wt cotton backing
- Ideal for aggressive stock removal applications
- Resistant to heat



MERIT

Size"	Grit	TS (Type II) Discs			TR (Type III) Discs		
		Model No.	Mfg. No.	Price /Each	Model No.	Mfg. No.	Price /Each
1-1/2	36	N0045	69957399626	0.54	-	-	-
1-1/2	40	N0046	69957399627	0.54	N0066	69957399695	0.54
1-1/2	50	N0047	69957399628	0.54	-	-	-
1-1/2	60	N0048	69957399629	0.54	-	-	-
1-1/2	80	N0049	69957399630	0.54	N0067	69957399698	0.54
1-1/2	100	N0050	69957399631	0.54	-	-	-
1-1/2	120	N0051	69957399632	0.54	N0068	69957399700	0.54
2	36	N0052	69957399638	0.81	N0069	69957399706	0.81
2	40	N0053	69957399639	0.81	N0070	69957399707	0.81
2	50	N0054	69957399640	0.81	N0071	69957399708	0.81
2	60	N0055	69957399641	0.81	N0072	69957399709	0.81
2	80	N0056	69957399642	0.81	N0073	69957399710	0.81
2	100	N0057	69957399643	0.81	N0074	69957399711	0.81
2	120	N0058	69957399644	0.81	N0075	69957399712	0.81
3	36	N0059	69957399650	1.16	N0076	69957399718	1.16
3	40	N0060	69957399651	1.16	N0077	69957399719	1.16
3	50	N0061	69957399652	1.16	N0078	69957399720	1.16
3	60	N0062	69957399653	1.16	N0079	69957399721	1.16
3	80	N0063	69957399654	1.16	N0080	69957399722	1.16
3	100	N0064	69957399655	1.16	N0081	69957399723	1.16
3	120	N0065	69957399656	1.16	N0082	69957399724	1.16



BACK UP PADS

Description	Max RPM	TS (Type II)		Price /Each	TR (Type III)		Price /Each
		Model No.	Mfg. No.		Model No.	Mfg. No.	
1 1/2" Medium	30 000	BR283	08834164146	16.40	BR104	08834161174	16.40
1 1/2" Hard	30 000	BR434	08834164622	16.40	BR437	08834164640	16.40
2" Medium	30 000	BR284	08834164198	18.10	BR469	08834164922	18.10
2" Hard	30 000	BR435	08834164624	18.10	BR439	08834164643	18.10
3" Medium	20 000	BR281	08834164113	20.00	BR475	08834164949	20.00
3" Hard	20 000	BR164	08834161626	20.00	BR272	08834164036	20.00

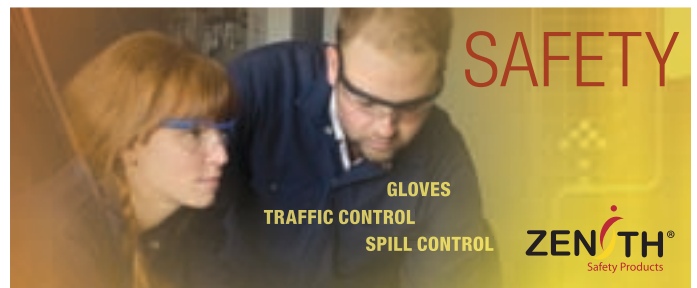

963G ROLOC™ DISCS

- Premium Cubitron™ abrasive grain
- Water resistant polyester cloth backing
- Resin bonded for heat resistance and it can be run wet or dry
- Used primarily for metal working and woodworking



REGAL™ RESIN BOND CLOTH

Model No.	Size"	Grit	Price /Each
AC435	2	24	1.38
AC436	2	36	1.28
AC437	2	50	1.18
AC438	2	60	1.15
AC439	2	80	1.10
AC440	2	100	1.10
AC441	2	120	1.10

Model No.	Size"	Grit	Price /Each
AC442	3	24	1.78
AC443	3	36	1.65
AC444	3	50	1.52
AC446	3	80	1.43
AC447	3	100	1.36
AC448	3	120	1.43

361F DISCS

- General purpose grinding, blending and deburring on all metals
- Heavy-duty cloth backing



ROLOC™

Model No.	Size"	Grit	Price /Each
BP336	2	24	0.95
BP338	2	36	0.88
BP340	2	50	0.83
BP342	2	60	0.78
BP344	2	80	0.77
BP346	2	P100	0.77
BP348	2	P120	0.77
BP350	2	P150	0.77
BP352	2	P180	0.77
BP353	2	P240	0.77
BP337	3	24	1.22
BP339	3	36	1.13
BP341	3	50	1.05
BP343	3	60	1.02
BP345	3	80	1.00
BP347	3	P100	1.00
BP349	3	P120	1.00
BP351	3	P150	1.00
BP354	3	P240	1.00

ROLOC™ TSM

Model No.	Size"	Grit	Price /Each
BP326	2	36	1.15
BP328	2	60	1.02
BP332	2	P100	0.98
BP329	3	60	1.35
BP331	3	80	1.28
BP333	3	P100	1.42
BP335	3	P120	1.28



ROLOC™ DISC PADS

Rubber back-up pads are available in different diameters and degrees of hardness for varying grinding applications. Pads are internally threaded to receive any standard 1/4"-20 thread shaft.



Model No.	Size"	Hardness	Max. RPM	Price /Each
BP008	2	Medium	25 000	21.30
BP005	2	Hard	25 000	19.50
BP009	3	Medium	18 000	23.80
BP006	3	Hard	20 000	23.80

ROLOC™ TSM DISC PADS

For use with Roloc™ TSM grinding discs and screw on abrasive discs.



Model No.	Size"	Hardness	Max. RPM	Price /Each
BP517	2	Medium	25 000	27.50
BP516	2	Hard	25 000	28.80
BP518	3	Hard	20 000	33.90

1/4" THREADED SHAFTS

Needed with all Roloc™ disc pads.

Model No.	Size"	Hardness	Price /Each
BP013	1/4 x 1/4	Thread	3.77

ALUMINUM OXIDE 2 PLY DISCS

- Best disc for general purpose grinding, deburring and blending on ferrous metals

Features

- Variety of Quick Change fastening systems
- Multiple layers of backing

Benefits

- Instant disc changes
- Disc is centered
- Smooth running
- Works well on flat or contour surfaces
- Aggressive stock removal
- Greater productivity

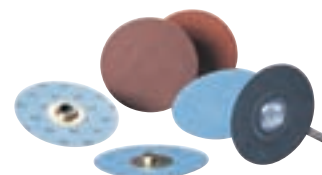

SOCATT™ DISCS

Model No.	Size"	Grit	Price /Each
VU392	2	24	0.92
VU393	2	36	0.90
VU394	2	40	0.95
VU395	2	50	0.88
VU396	2	60	0.89
VU397	2	80	0.88
VU398	2	100	0.86
VU399	2	120	0.87
VU400	2	150	0.78
VU401	2	180	0.78
VU402	2	240	0.86

Model No.	Size"	Grit	Price /Each
VU403	2	320	0.82
VU405	3	36	1.25
VU406	3	40	1.21
VU407	3	50	1.07
VU408	3	60	1.14
VU409	3	80	1.12
VU410	3	100	1.09
VU411	3	120	1.09
VU413	3	180	1.20
VU414	3	240	1.09
VU415	3	320	1.21

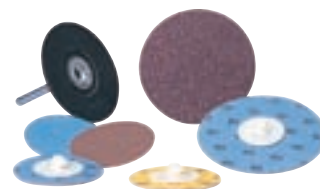

LOCKIT™ DISCS

Model No.	Size"	Grit	Price /Each
VU429	2	36	1.00
VU430	2	40	0.95
VU431	2	50	0.92
VU432	2	60	0.85
VU433	2	80	0.88
VU434	2	100	0.86
VU435	2	120	0.86
VU436	2	150	0.75
VU437	2	180	0.86
VU438	2	240	0.86
VU439	2	320	0.85

Model No.	Size"	Grit	Price /Each
VU442	3	40	1.21
VU443	3	50	1.02
VU444	3	60	0.99
VU445	3	80	1.12
VU446	3	100	1.12
VU447	3	120	1.12

HOLDER PADS

- With mandrel



Model No.	Dia."	Density	Price /Each
FOR SMALL DIAMETER SOCATT™ DISCS			
VU601	2	Soft	17.68
VU602	2	Medium	16.97
VU603	2	Firm	20.20
VU604	3	Soft	21.53
VU605	3	Medium	19.62
VU606	3	Firm	23.37
FOR SMALL DIAMETER LOCKIT™ DISCS			
VU611	2	Medium	16.97
VU612	2	Firm	20.20
VU613	3	Soft	21.53
VU614	3	Medium	19.62

PSA & HOOK AND LOOP PAPER DISCS

Typical Applications

- Preparing primed and painted surfaces for finishing
- Stripping primer and paint
- Sanding of plastic and fibreglass
- Light weld blending and deburring
- Bare wood sanding
- Finishing metal of all types

NO-FIL ADALOX A275 DISCS

- Premium P-graded, heat-treated aluminum oxide abrasive, superior life fast cut rate, consistent finish
- Unique fibre-reinforced, B-wt latex-saturated backing, 50-60% improvement in tears strength and can be used wet
- Water-based stearate, non-pigmented, No-Fil coating, provides maximum load resistance and extended life; no colour transfer to work
- The PSA adhesive is protected from air-borne contaminants
- Hook and loop are reusable discs that reduce waste



PB273 PAPER DISCS

- P-graded aluminum oxide abrasive
- Fast cutting action and extended life with consistent finish
- Flexible latex B-wt backing, with a full resin bond and open coat
- Improved resistance to delamination; no delamination to back-up pad
- Can be used moist or wet
- Water-based stearate, non-pigmented No-Fil coating provides improved load resistance and no color transfer to work



Model No.	Mfg. No.	Size"	Grit	Price /Each
-----------	----------	-------	------	-------------

HOOK AND LOOP PAPER DISCS

NZ005	66261131549	5	P80	0.82
NZ006	66261131548	5	P100	0.75
NZ007	66261131547	5	P120	0.75
NZ008	66261131546	5	P150	0.75
NZ009	66261131545	5	P180	0.75
NZ010	66261131544	5	P220	0.75
NZ011	66261131543	5	P240	0.75
NZ012	66261131542	5	P280	0.75
NZ013	66261131541	5	P320	0.75
NZ014	66261131539	5	P400	0.75
NZ015	66261131538	5	P500	0.75
NZ016	66261131537	5	P600	0.86
NZ017	66261131536	5	P800	0.86
NZ021	6626113566	6	P80	1.20
NZ022	6626113565	6	P100	1.06
NZ023	6626113564	6	P120	1.06
NZ024	6626113563	6	P150	1.06
NZ025	6626113562	6	P180	1.06
NZ026	6626113561	6	P220	1.06
NZ027	6626113560	6	P240	1.06
NZ028	6626113559	6	P280	1.06
NZ029	6626113558	6	P320	1.06
NZ030	6626113556	6	P400	1.06
NZ031	6626113555	6	P500	1.06
NZ032	6626113554	6	P600	1.06
NZ033	6626113553	6	P800	1.06

STICK AND SAND PAPER DISCS

NS025	66261131464	5	P80	64.60
NS675	66261131463	5	P100	59.50
NS030	66261131462	5	P120	59.50
NS029	66261131461	5	P150	59.50
NS028	66261131460	5	P180	59.50
NS027	66261131459	5	P220	59.50
NS026	66261131458	5	P240	59.50
NS676	66261131457	5	P280	59.50
NS677	66261131456	5	P320	59.50
NS678	66261131454	5	P400	59.50
NS679	66261131453	5	P500	59.50
NS680	66261131452	5	P600	59.50
NS681	66261131451	5	P800	59.50
NS018	66261131481	6	P80	91.20
NS019	66261131480	6	P100	84.30
NS020	66261131479	6	P120	84.30
NS682	66261131478	6	P150	84.30
NS021	66261131477	6	P180	84.30
NS022	66261131476	6	P220	84.30
NS023	66261131475	6	P240	84.30
NS683	66261131474	6	P280	84.30
NS024	66261131473	6	P320	84.30
NZ001	66261131471	6	P400	84.30
NZ002	66261131470	6	P500	84.30
NZ003	66261131469	6	P600	84.30
NZ004	66261131468	6	P800	84.30

Model No.	Mfg. No.	Size"	Grit	Price /Each
-----------	----------	-------	------	-------------

HOOK AND LOOP DISCS

NR896	66623362950	5	P80-B	0.57
NR897	66623365788	5	P100-B	0.50
NR898	66623362949	5	P120-B	0.50
NR899	66623362948	5	P150-B	0.50
NR900	66623362947	5	P180-B	0.50
NR901	66623362946	5	P220-B	0.50
NR902	66623362945	5	P240-B	0.50
NR903	66623362944	5	P320-B	0.50
NR904	66623362943	5	P400-B	0.50
NR906	66623362942	5	P600-B	0.50
NR907	66623362941	5	P800-B	0.50
NR908	66623362960	6	P80-B	0.60
NR909	66623365789	6	P100-B	0.53
NR910	66623362959	6	P120-B	0.53
NR911	66623362958	6	P150-B	0.53
NR912	66623362957	6	P180-B	0.53
NR913	66623362956	6	P220-B	0.53
NR914	66623362955	6	P240-B	0.53
NR915	66623362954	6	P320-B	0.53
NR916	66623362953	6	P400-B	0.53
NR917	66623362952	6	P600-B	0.53
NR918	66623362951	6	P800-B	0.53

PSA DISCS

NR919	66623362930	5	P80-B	43.50
NR921	66623362929	5	P120-B	37.90
NR922	66623362928	5	P150-B	37.90
NR923	66623362927	5	P180-B	37.90
NR924	66623362926	5	P220-B	37.90
NR925	66623362925	5	P240-B	37.90
NR926	66623362924	5	P320-B	37.90
NR927	66623362923	5	P400-B	37.90
NR928	66623362922	5	P600-B	37.90
NR929	66623362921	5	P800-B	37.90
NR930	66623362940	6	P80-B	59.60
NR931	66623362939	6	P120-B	51.80
NR932	66623362938	6	P150-B	51.80
NR933	66623362937	6	P180-B	51.80
NR934	66623362936	6	P220-B	51.80
NR935	66623362935	6	P240-B	51.80
NR936	66623362934	6	P320-B	51.80
NR937	66623362933	6	P400-B	51.80
NR938	66623362932	6	P600-B	51.80
NR939	66623362931	6	P800-B	51.80

NX PSA WHITE GOLD DISC ROLL

- With paper backing
- Excellent for sanding on whitewood, primer, paint sealers and topcoats
- Primary uses are for woodworking and metalworking
- Clear, non-staining stearate coating resists loading
- 100 discs per roll



Model No.	Mfg. No.	Size"	Grade	Price /Each
BP632	051141-31181	5	80A	29.70
BP631	051141-31182	5	P100	29.70
BP633	051141-31183	5	P120	29.70
BP635	051141-31184	5	P150A	29.70
BP637	051141-31185	5	P180A	29.70
BP639	051141-31186	5	P220A	29.70
BP642	051141-27676	5	P400A	28.27
NX244	051141-31189	6	80	39.00
NX237	051141-31190	6	P100	39.00
NX238	051141-31191	6	P120	39.00
NX239	051141-31192	6	P150	39.00
NX240	051141-31193	6	P180	39.00
NX241	051141-31194	6	P220	39.00
NX242	051141-27675	6	P320	39.00

236U STIKIT™ DISC ROLLS

- Aluminum oxide C-wt paper
- Strong paper backing provides durability and increase cut rate
- Open coat minimizes loading
- Discs for paint, primer, wood, metal, plastic and fiberglass
- 100 discs per roll, no holes



Model No.	Mfg. No.	Size"	Grade	Price /Each
NX291	AB86488	5	P80	36.20
NX282	AB86489	5	P100	36.20
NX283	AB88700	5	P120	36.20
NX284	AB86490	5	P150	36.20
NX285	AB86492	5	P180	36.20
NX286	AB86493	5	P220	36.20
NX287	AB86494	5	P240	36.20
NX289	AB86496	5	P400	36.20
NX290	AB86497	5	P500	36.20
NX301	AB86468	6	P80	48.00
NX292	AB86469	6	P100	48.00
NX293	AB86470	6	P120	48.00
NX294	AB86471	6	P150	48.00
NX295	AB86472	6	P180	48.00
NX296	AB86473	6	P220	48.00
NX297	AB86474	6	P240	48.00
NX298	AB86475	6	P320	48.00
NX299	AB86476	6	P400	48.00
NX300	AB86477	6	P500	48.00

BACK UP PADS FOR PSA & HOOK AND LOOP PAPER DISCS

- Available with PSA or hook and loop faces, both are shock resistant and have a fiberglass backing plate with a riveted 5/16"-24 threaded shank for added strength and increased heat resistance
- Low profile pads, soft density utilizes 1/2" thick foam for fine finish sanding and offer moderate conformability and medium density has 1/2" thick urethane foam for intermediate and finish sanding



NORTON

Model No.	Mfg No.	Description	Max RPM	Price /Each
NR940	63642506126	5" PSA Soft Low Profile	15 000	39.50
NR941	63642506131	5" PSA Medium Low Profile	15 000	24.10
NR943	63642506129	5" NorGrip Soft Low Profile	15 000	42.30
NZ049	63642506135	5" NorGrip Medium Low Profile	15 000	26.30
NR945	63642506127	6" PSA Soft Low Profile	15 000	42.10
NR946	63642506133	6" PSA Medium Low Profile	15 000	42.10
NR948	63642506130	6" NorGrip Soft Low Profile	15 000	52.50
NR947	63642506137	6" NorGrip Medium Low Profile	15 000	52.50

STIKIT™ DISC PADS

- Provides excellent disc adhesion yet allows quick, easy removal
- Has medium density foam and a 45° tapered edge for flexibility
- Lightweight and shock-resistant with blue vinyl face
- Use with dual action and random orbital sanders; maximum RPM of 10 000



Model No.	Dimensions	For use with	Price /Each
BP215	5" x 3/4" x 5/16-24 Ext	5" Stikit™ Discs	22.20
BP216	6" x 3/4" x 5/16-24 Ext	6" Stikit™ Discs	43.50

LARGE DIAMETER CLOTH PSA DISCS

Typical Applications

- Used on stationary disc machines
- For dimensioning
- For finishing metal workpieces
- Pressure sensitive adhesive offers fast, convenient mounting
- Made without centre holes for full-face usage

NORZON PLUS R821P DISCS

- Self-sharpening, zirconia alumina abrasive, offers cooler cut and extended life
- Heavy Y-wt backing, is durable, reduced edge wear
- Ideal for grinding and deburring stainless steel



NORTON

Model No.	Mfg. No.	Size"	Grit	Price /Each
NZ057	66261138318	12	24	18.60
NZ058	66261138319	12	36	17.60
NZ059	66261138320	12	40	16.40
NZ060	66261138321	12	50	15.40
NZ061	66261138322	12	60	14.50
NZ062	66261138323	12	80	13.40

METALITE R228 DISCS

- Premium aluminum oxide abrasive
- Long life
- Heavy, X-wt cotton backing
- Durable
- Ideal for aggressive stock removal applications
- Resistant to heat



NORTON

Model No.	Mfg. No.	Size"	Grit	Price /Each
NZ077	66261136635	12	36	10.60
NZ078	66261136630	12	40	10.00
NZ079	66261136625	12	50	9.50
NZ080	66261136620	12	60	8.94
NZ081	66261136615	12	80	8.40
NZ082	66261136614	12	100	7.96
NZ083	66261136613	12	120	7.96

ABRASIVES

FILE BELTS

Typical Applications

- Light weld removal and blending
- Shape and contour sanding
- Surface preparation prior to coating and plating
- Removing cutting tool marks from moulds and dies
- General clean-up and finishing



NORTON SG BLAZE R980P BELTS

- SG ceramic abrasive grain lasts 50% to 200% longer on mild and carbon steel, stainless, cobalt, chrome, inconel and titanium
- Cuts 20% faster than the current generation of grinding belts, longer belt life, better metal integrity
- Improved Y-wt polyester waterproof cloth backing, significantly improved belt life due to better grain adhesion
- Improved resin bond system, improved grain-retention, cooler cutting during the life of the belt

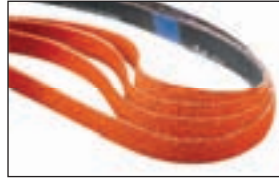

NORTON

Model No.	Mfg. No.	Size			Grit	Price /Each
		W"	x	L"		
NR091	69957398018	1/2	x	12	40	2.37
NR092	69957698019	1/2	x	12	60	2.29
NR093	69957398020	1/2	x	12	80	2.22
NR094	69957398021	1/2	x	18	40	2.54
NR095	69957398022	1/2	x	18	60	2.41
NR096	69957398023	1/2	x	18	80	2.33
NR097	69957398024	1/2	x	24	40	2.81
NR098	69957398025	1/2	x	24	60	2.60
NR099	69957398026	1/2	x	24	80	2.41
NR100	69957398027	3/4	x	18	40	2.85
NR101	69957398028	3/4	x	18	60	2.68
NR102	69957398029	3/4	x	18	80	2.51

NORZON PLUS R823P BELTS

- Premium, self-sharpening zirconia alumina abrasive
- Aggressive, rapid cut rate, strong grain adhesion, longer life
- Waterproof for use on a broad range of materials
- Strong X-wt polyester backing, for moderate to heavy pressure applications
- Ideal on stainless steel



NORTON

Model No.	Mfg. No.	Size			Grit	Price /Each
		W"	x	L"		
NZ178	78072728745	1/2	x	12	60	1.35
NZ179	78072728744	1/2	x	12	80	1.16
NZ180	78072728742	1/2	x	12	120	0.96
NZ181	78072728569	1/2	x	18	60	1.39
NZ182	78072728568	1/2	x	18	80	1.35
NZ183	78072728567	1/2	x	18	120	1.06
NZ184	78072728564	1/2	x	24	60	1.45
NZ185	78072728566	1/2	x	24	80	1.39
NZ187	78072728565	1/2	x	24	120	1.27
NZ188	78072709590	3/4	x	18	60	1.62
NZ189	78072758953	3/4	x	18	80	1.52
NZ194	78072728583	1	x	30	60	2.89
NZ195	78072728582	1	x	30	80	2.66

METALITE R228 BELTS

- Aluminum oxide abrasive
- Aggressive cutting; resistant to heat
- Strong X-wt rayon backing
- For metal and wood



NORTON

Model No.	Mfg. No.	Size			Grit	Price /Each
		W"	x	L"		
NZ410	78072727557	1/2	x	12	40	0.92
NZ411	78072727555	1/2	x	12	60	0.92
NZ412	78072727554	1/2	x	12	80	0.83
NZ414	78072727552	1/2	x	12	120	0.75
NZ415	78072727561	1/2	x	18	40	0.96
NZ416	78072727560	1/2	x	18	60	0.94
NZ417	78072727559	1/2	x	18	80	0.92
NZ418	78072727558	1/2	x	18	120	0.83
NZ419	78072727568	1/2	x	24	40	0.98
NZ421	78072727566	1/2	x	24	60	0.98
NZ422	78072727565	1/2	x	24	80	0.94
NZ423	78072727564	1/2	x	24	120	0.98
NZ429	78072727579	1	x	30	80	1.83
NZ430	78072727577	1	x	30	120	2.02

PORTABLE BELTS

Typical Applications

- Grinding and finishing of all metals
- Blending of welds
- Sanding and finishing of wood
- Glass seaming and polishing



METALITE R228 BELTS

- Aluminum oxide abrasive
- Aggressive cutting; resistant to heat
- Strong X-wt cotton backing
- For metal and wood

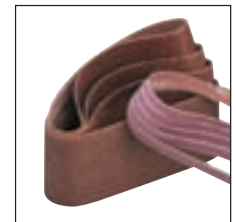

NORTON

Model No.	Mfg. No.	Size			Grit	Price /Each
		W"	x	L"		
NZ283	78072727927	3	x	21	40	2.77
NZ284	78072727926	3	x	21	50	2.68
NZ285	78072727925	3	x	21	60	2.60
NZ286	78072727924	3	x	21	80	2.49
NZ287	78072727923	3	x	21	100	2.39
NZ288	78072727922	3	x	21	120	2.39
NZ289	78072781847	3	x	24	36	3.18
NZ290	78072727937	3	x	24	40	2.99
NZ291	78072727936	3	x	24	50	2.83
NZ292	78072727935	3	x	24	60	2.77
NZ293	78072727934	3	x	24	80	2.66
NZ294	78072727933	3	x	24	100	2.54
NZ295	78072727932	3	x	24	120	2.54
NZ302	78072780438	4	x	24	36	5.36
NZ303	78072727947	4	x	24	40	4.82
NZ304	78072727946	4	x	24	50	4.64
NZ305	78072727945	4	x	24	60	4.49
NZ306	78072727944	4	x	24	80	4.26
NZ307	78072727943	4	x	24	100	4.09
NZ308	78072727942	4	x	24	120	4.09

Ask us about volume prices!

In many cases you will benefit from quantity prices.



STATIONARY BELTS

Typical Applications

- Benchstand and backstand belts
- Grinding and deburring of all metals
- Heavy stock removal
- Blending, dimensioning and shaping
- Polishing

NORZON PLUS R823P BELTS

- Premium self-sharpening zirconia alumina abrasive, aggressive, rapid cut rate
- Strong X-wt polyester backing; waterproof, greater flexibility, ideal for heavy pressure applications



NORTON

Model No.	Mfg. No.	Size			Grit	Price /Each
		W"	x	L"		
NZ196	78072728596	1	x	42	60	2.91
NZ197	78072728594	1	x	42	80	2.76
NZ198	78072728592	1	x	42	100	2.60
NZ199	78072728590	1	x	42	120	2.60
NZ200	78072728586	1	x	42	180	2.60
NZ215	78072728827	4	x	36	60	7.75
NZ216	78072728825	4	x	36	80	7.11
NZ217	78072728821	4	x	36	120	6.80
NZ218	78072728937	6	x	48	60	13.00
NZ219	78072728935	6	x	48	80	11.80
NZ220	78072728933	6	x	48	100	11.40
NZ221	78072728931	6	x	48	120	11.40

SPIRAL BANDS

Typical Applications

- Deburring
- Polishing
- Surface preparation

Features & benefits

- Spiral construction avoids shadow marks and provides smooth cutting action
- Achieve close tolerances when finishing curved or contoured areas

SPIRAL BANDS

- Aluminum oxide resin bond



NORTON

Model No.	Mfg. No.	Size"			Grit	Price /Each
		W"	x	L"		
BZ251	08834196068	1/2	x	1/2	60	88.60
BZ288	08834196179	1/2	x	1/2	80	88.60
BZ252	08834196069	1/2	x	1/2	120	88.60
BZ307	08834196212	1/2	x	1	60	92.50
BZ309	08834196215	1/2	x	1	80	92.50
BZ305	08834196210	1/2	x	1	120	92.50
BZ401	08834196554	3/4	x	1	60	112.00
BZ328	08834196249	3/4	x	1	80	112.00
BZ244	08834196057	3/4	x	1	120	110.00
BZ257	08834196074	1	x	1	80	104.00
BZ278	08834196167	1	x	1	100	98.30
BZ286	08834196177	1	x	1	120	98.30
BZ247	08834196060	1	x	1 1/2	60	121.00
BZ274	08834196162	1	x	1 1/2	80	118.00
BZ443	08834196677	1	x	1 1/2	120	116.00
BZ289	08834196181	2	x	2	80	183.00
BZ298	08834196193	2	x	2	100	177.00
BZ412	08834196585	2	x	2	120	177.00
BZ296	08834196188	3	x	3	60	330.00
BZ272	08834196159	3	x	3	80	320.00
BZ407	08834196572	3	x	3	120	312.00

METALITE R228 BELTS

- Aluminum oxide abrasive
- For a wide range of metalworking applications
- Strong X-wt cotton backing, aggressive cutting/resistant to heat



NORTON

Model No.	Mfg. No.	Size			Grit	Price /Each
		W"	x	L"		
NZ309	78072720910	1	x	42	40	2.52
NZ310	78072720905	1	x	42	50	2.49
NZ311	78072720900	1	x	42	60	2.43
NZ312	78072720895	1	x	42	80	2.33
NZ313	78072720890	1	x	42	100	2.29
NZ314	78072720885	1	x	42	120	2.29
NZ315	78072720880	1	x	42	150	2.29
NZ316	78072720875	1	x	42	180	2.29
NZ317	78072720871	1	x	42	220	2.29
NZ318	78072720870	1	x	42	240	2.29
NZ319	78072720865	1	x	42	320	2.29
NZ354	78072722110	4	x	36	36	6.74
NZ355	78072722105	4	x	36	40	8.88
NZ356	78072722100	4	x	36	50	8.56
NZ357	78072722095	4	x	36	60	8.27
NZ358	78072722090	4	x	36	80	7.86
NZ359	78072722085	4	x	36	100	7.65
NZ360	78072722080	4	x	36	120	7.65
NZ361	78072722079	4	x	36	150	5.57
NZ362	78072722075	4	x	36	180	5.57
NZ363	78072722071	4	x	36	320	5.57
NZ371	78072722590	6	x	48	36	16.60
NZ372	78072722585	6	x	48	40	15.90
NZ373	78072722580	6	x	48	50	15.20
NZ374	78072722575	6	x	48	60	14.50
NZ375	78072722570	6	x	48	80	10.60
NZ376	78072722565	6	x	48	100	13.50
NZ377	78072722560	6	x	48	120	13.50
NZ378	78072722555	6	x	48	150	10.20
NZ379	78072722550	6	x	48	180	10.20
NZ380	78072722546	6	x	48	220	10.20
NZ381	78072722545	6	x	48	240	10.20
NZ382	78072722543	6	x	48	320	10.20

CARTRIDGE ROLLS

MERIT

Typical Applications

- Flash removal
- Polishing
- Removing machine tool marks and edge breaking

Features & benefits

- Can reach into corners where larger diameter tools cannot

CARTRIDGE ROLLS TEST KIT CR

- Includes 120 of the most popular sizes, grit and shape with their appropriate mandrels

Model No. BS529
Price/Each \$93.40



ABRASIVES

SHOP CLOTH ROLLS

Typical Applications

- Polishing lathe turnings, rolls and cylinders
- Light deburring
- Blending machine tool marks
- Removing rust and scale
- Fine sanding and polishing

METALITE K225 CLOTH SHOP ROLLS

- For general purpose metalworking applications
- Premium P-graded aluminum oxide abrasive produces greater cut rate
- Flexible J-wt cotton backing offers superior conformability to complex surfaces and better finishes
- Advanced full resin bond system offers exceptional grain adhesion for longer life



NORTON

Model No.	Mfg. No.	Grit	Price /Each
1" X 50 YARD			
NS204	66261058716	40	41.10
NS205	66261127728	50	40.90
NS206	66261127729	60	40.20
NS212	66261126276	80	42.10
NS213	66261126275	100	40.70
NS214	66261126274	120	40.70
NS215	66261126273	150	40.70
NZ846	66261126270	240	40.70
NZ847	66261126268	320	40.70
NZ887	66261126267	400	40.70
1 1/2" X 50 YARD			
NZ888	66261058715	40	58.40
NZ890	66261127731	60	56.20
NZ891	66261126288	80	58.90
NZ892	66261126287	100	57.00
NZ893	66261126286	120	57.00

Model No.	Mfg. No.	Grit	Price /Each
1 1/2" X 50 YARD			
NZ894	66261126285	150	57.00
NZ951	66261126284	180	57.00
NZ953	66261126282	240	57.00
NZ955	66261126280	320	57.00
NZ957	66261126279	400	57.00
2" X 50 YARD			
NZ959	66261058714	40	75.80
NZ995	66261127732	50	75.10
NZ996	66261127733	60	73.70
NS048	66261126299	80	74.90
NZ997	66261126298	100	72.50
NS049	66261126297	120	72.50
NS050	66261126296	150	72.50
NS051	66261126295	180	72.50
NZ998	66261126293	240	72.50
NZ999	66261126291	320	72.50
NR001	66261126290	400	72.50

METALITE K227 CLOTH SHOP ROLLS

- The choice for quality metal finishing
- P-graded aluminum oxide abrasive grain produces fast cut rate and consistent finish
- Flexible J-wt cotton backing offers superior conformity to complex surfaces and better finishes
- Resin bond system for longer life



NORTON

Model No.	Mfg. No.	Grit	Price /Each
1 1/2" X 50 YDS			
NR132	66261109255	P80-J	49.20
NR133	66261058719	P100-J	47.40
NR134	66261109245	P120-J	47.40
NR135	66261058717	P150-J	47.40
NR136	66261109235	P180-J	47.40
NR137	66261109225	P280-J	47.40
NR138	66261109215	P320-J	47.40

Model No.	Mfg. No.	Grit	Price /Each
2" X 50 YDS			
NR139	66261109335	P80-J	63.00
NR140	66261109330	P100-J	60.70
NR141	66261109325	P120-J	60.70
NR142	66261109320	P150-J	60.70
NR143	66261109315	P180-J	60.70
NR144	66261109305	P280-J	60.70
NR145	66261109295	P320-J	60.70

314D PROFESSIONAL CLOTH SHEETS

- Cleaning metal prior to soldering or welding
- Repairing and blending metal finishes and removing stamping marks
- Fine sanding and polishing
- Removing rust, scale and other contaminants
- Hand or machine deburring



3M

9" X 11" SHEETS

Model No.	Mfg. No.	Grit	Price /Each
BP672	60333	50X	1.00
BP673	60334	60X	0.95
BP671	60342	80J	0.83
BP664	60343	100J	0.80
BP665	60344	120J	0.80
BP666	60345	150J	0.80
BP667	60346	180J	0.80
BP668	60347	220J	0.80
BP669	60348	240J	0.80
BP670	60349	280J	0.80

ROLLS

Model No.	Mfg. No.	Grit	Price /Each
1" X 50 YARD			
BP660	60326	50X	19.60
BP662	60325	60X	18.50
BP657	60686	80J	16.20
BP643	60687	100J	15.30
BP645	60688	120J	15.30
BP647	60689	150J	15.30
BP649	60690	180J	15.30
BP651	60691	220J	15.30
BP653	60692	240J	15.30
BP655	60693	280J	15.30

ROLLS

Model No.	Mfg. No.	Grit	Price /Each
1 1/2" X 50 YARD ROLLS			
BP624	60327	50X	29.40
BP625	60328	60X	27.70
BP623	60697	80J	24.30
BP616	60698	100J	22.80
BP617	60699	120J	22.80
BP618	60700	150J	22.80
BP619	60701	180J	22.80
BP620	60702	220J	22.80
BP621	60703	240J	22.80
BP622	60704	280J	22.80
2" X 50 YARD ROLLS			
BP659	60329	40X	42.10
BP661	60330	50X	39.10
BP663	60331	60X	36.90
BP658	60708	80J	32.40
BP644	60709	100J	30.40
BP646	60710	120J	30.40
BP648	60711	150J	30.40
BP650	60712	180J	30.40
BP652	60713	220J	30.40
BP654	60714	240J	30.40
BP656	60715	280J	30.40

See pages
1356 - 1359
for Scissors
and Snips



SANDPAPER, CLOTH SHEETS

Typical Applications

- Scouring and light deburring
- Scale and rust removal
- Blending machine tool marks
- Fine sanding and polishing

METALITE K225 9" X 11" SHEETS

- Premium P-graded aluminum oxide abrasive
- Advanced full resin bond system offers exceptional grain adhesion for longer life
- Flexible J-wt cotton backing, for superior conformability to complex surfaces and better finishes



NORTON

Model No.	Mfg. No.	Grit	Price /Each
NR103	66261058713	40	2.12
NR104	66261101862	50	1.93
NR105	66261101861	60	1.81
NZ455	66261126340	80	1.56
NZ456	66261126339	100	1.46
NZ457	66261126338	120	1.46
NZ458	66261126337	150	1.46
NZ459	66261126336	180	1.46
NZ460	66261126335	220	1.46
NZ461	66261126334	240	1.46
NZ462	66261126333	280	1.46
NZ463	66261126332	320	1.46
NZ464	66261126331	400	1.46
NZ465	66261126330	600	1.46

SANDPAPER, PAPER SHEETS

Typical Applications

- Light duty, metal sanding
- Primer sanding, defect removal from painted surfaces
- Filler sanding
- Sanding and finishing of composites and fiberglass
- Bare wood sanding
- Sanding between sealer coats

NO-FIL ADALOX A275 9" X 11" SHEETS

- Premium P-graded, heat-treated aluminum oxide abrasive
- Unique fibre-reinforced, B-wt latex-saturated backing, can be used wet
- Water-based serrated, non-pigmented, No-Fil coating, provides maximum load resistance and extended life; no colour transfer to work



NORTON

Model No.	Mfg. No.	Grit	Price /Each
NZ431	66261131634	80	1.12
NZ432	66261131633	100	1.04
NZ433	66261131632	120	1.04
NZ434	66261131631	150	1.04
NZ435	66261131630	180	1.04
NZ436	66261131629	220	1.04
NZ437	66261131628	240	1.04
NZ438	66261131627	280	1.04
NZ439	66261131626	320	1.04
NZ440	66261131624	400	1.04
NZ441	66261131623	500	1.04
NZ442	66261131622	600	1.04
NZ443	66261131621	800	1.04

BLUE-BAK T414 WATERPROOF 9" X 11" SHEETS

- Sharp silicon carbide abrasive, exceptional finishes in wet applications
- Strong resin bond, longer life in wet applications
- High strength B-wt waterproof paper backing, extremely flexible
- Environmentally stable; resists humidity-caused curling

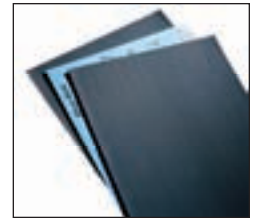

NORTON

Model No.	Mfg. No.	Grit	Price /Each
NZ447	66261139367	220	1.21
NZ448	66261139366	240	1.21
NZ449	66261139365	280	1.21
NZ450	66261139364	320	1.21
NZ451	66261139363	360	1.21
NZ452	66261139362	400	1.21
NZ453	66261139361	500	1.21
NZ454	66261139360	600	1.21

NO-FILL DURITE A475 9" X 11" SHEETS

- P-graded silicone carbide abrasive offers easy penetration of the hardest surfaces
- Water-based stearate, non-pigmented, no-fill coating resists loading for longer usable product life, no color transfer to work
- Fibre-reinforced latex paper backing provides flexibility and resistance to tearing
- Ideal choice for gel coats, hard composite substrates, abrasion-resistant coatings and woodworking application

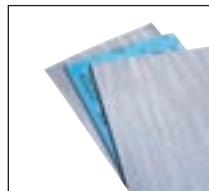

NORTON

Model No.	Mfg. No.	Grit	Price /Each
NR856	66254487393	P80-B	0.96
NR857	66254487394	P100-B	0.83
NR858	66254487395	P120-B	0.83
NR859	66254487396	P150-B	0.83
NR860	66254487397	P180-B	0.83
NR861	66254487398	P220-B	0.83
NR862	66254487399	P240-B	0.83
NR863	66254487400	P320-B	0.83

GARNET A511 9" X 11" SHEETS

- Natural garnet grain
- Excellent for soft woods, consistent finishes, A-weight paper
- Designed for heavy-duty to light-duty hand and machine sanding



NORTON

Model No.	Mfg. No.	Grit	Price /Each
NR114	66261101505	80	0.79
NR115	66261101500	100	0.67
NR116	66261101495	120	0.67
NR117	66261101490	150	0.67
NR118	66261101489	180	0.67
NR119	66261101488	220	0.67

ABRASIVES

GARNET ABRASIVE PAPER

140N - (D weight paper)

- Open coat for non-loading
- Choice of cabinet makers and woodworkers

110N - (A weight paper)

- Open coat for non-loading
- Traditional choice for woodworkers for producing fine finishes



Model No.	Size"	Grit	Price /Each
140N			
BP539	9 x 11	50	0.88
BP540	9 x 11	60	0.88
BP541	9 x 11	80	0.68
110N			
BP531	9 x 11	100	0.45
BP532	9 x 11	120	0.45
BP533	9 x 11	150	0.45
BP534	9 x 11	180	0.45
BP535	9 x 11	220	0.45

TRI-M-ITE FRE-CUT ABRASIVE PAPER

415U/415N (A weight paper - open coat)

- Silicon carbide mineral cuts fast and smooth
- Ideal for sanding between coats of varnish, paint and other finishes
- Especially suited to wood and sealer sanding



Model No.	Size"	Grit	Price /Each
BP548	9 x 11	100	0.77
BP549	9 x 11	120	0.77
BP550	9 x 11	150	0.77
BP552	9 x 11	180	0.77
BP554	9 x 11	220	0.77
BP555	9 x 11	240	0.77
BP556	9 x 11	280	0.77
BP557	9 x 11	320	0.77

WETORDRY™ ABRASIVE PAPER

- Reduces clogging, eliminates dust, extends abrasive life and improves finish

431Q - (Silicon carbide - C weight paper)

- Heavyweight paper backing for increased durability

413Q - (Silicon carbide - A weight paper)

- Excellent conformability

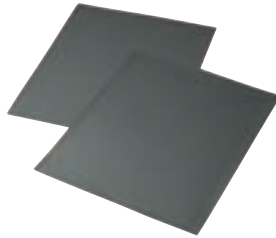

Model No.	Size"	Grit	Price /Each
431Q			
BP572	9 x 11	80	1.80
BP565	9 x 11	100	1.57
BP566	9 x 11	120	1.35
BP567	9 x 11	150	1.28
BP568	9 x 11	180	1.20
413Q			
BP559	9 x 11	220	1.15
BP560	9 x 11	240	1.15
BP561	9 x 11	280	2.30
BP562	9 x 11	320	1.15
BP563	9 x 11	360	1.07
BP564	9 x 11	400	1.16

For Sheet Sanders
see page 1180



HAND PADS

Typical Applications

- Light to heavy duty cleaning
- Deburring
- Blending
- Polishing
- Finishing

Features & benefits

- Made of a nonwoven nylon web impregnated with abrasive grain and resin
- A variety of abrasives, grit sizes and backing materials provides an extensive and superior product offering
- Can be used instead of steel wool
- Non-loading, non-rusting, waterproof and solvent resistant

SCOTCH-BRITE™ HAND PADS

- Excellent products for hand finishing, polishing, cleaning, blending, deburring of wood, metals and composites
- Ideal for wood finishing, paint preparation and general cleaning
- 6" x 9" sheets (model BP493 is 4" x 6")
- Can be used dry or with water or solvents



Model No.	Type of Pad	Colour	Finish	Price /Each
BP486	Heavy-duty	Tan	Coarse	3.43
BP482	Blending	Grey	Medium	2.30
BP484	General purpose	Maroon	Very Fine	1.11
BP492	Ultra fine	Light Grey	Ultra fine	1.11
BP488	Cleaning	White	Cleaning	1.50
NC871	General purpose #96	Green	Scouring	1.06

SANDING SPONGES

- Sponges form perfectly to corners, contours and flat surfaces
- Can be used on all surfaces, from wood, metal and plastic, to coated or painted surfaces
- Sponges are all 4 1/2" x 5 1/2" in size and have a soft sponge in the centre

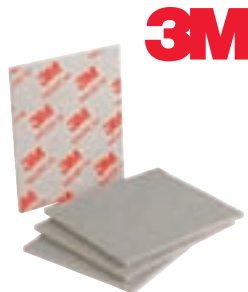

Model No.	Grit	Price /Each
BP629	Medium	3.35
BP628	Fine	3.35
BP630	Super Fine	3.35

BEAR-TEX HAND PADS

- Flexible, gentle action and resilient construction
- Conform to work surface and easily remove flashing or burrs without affecting dimension of work piece
- Non-loading, non-rusting, constant supply of new cutting edges, no workpiece contamination



Model No.	Colour	Description	Abrasive	Grit	Qty /Pkg.	Price /Each
NZ811	White	Light-Duty Cleaning Pad	Non-Abrasive	-	60	1.62
NZ812	Grey	Clean and Finish Pad	Silicon Carbide	Ultra Fine	60	1.46
NZ813	Light Green	Food Pro Pad	Aluminum Oxide	Very Fine	60	0.60
NS046	Dark Tan	Heavy-Duty Pad	Aluminum Oxide	Medium	40	3.76
NZ814	Grey	Metal Blend Pad	Silicon Carbide	Medium	40	2.43
NS045	Maroon	General Purpose Pad	Aluminum Oxide	Very Fine	60	1.46
NZ815	Grey	Final Shine Pad	Silicon Carbide	Micro Fine	60	1.46
NZ816	Maroon	Long Life Pad	Aluminum Oxide	Very Fine	60	1.46
NZ817	Green	Scouring Pad	Aluminum Oxide	Very Fine	60	1.46
NZ818	Maroon	General Purpose Perforated Pad	Aluminum Oxide	Very Fine	60	1.50
NZ819	Grey	General Purpose Pad	Silicon Carbide	Very Fine	40	2.25
NZ820	-	Hand Pad Holder	-	-	10	6.92

SCOTCH-BRITE™ SHEET ROLLS

- Tough, highly flexible, sharp cutting abrasive
- High flexibility makes for easy cleaning and finishing surfaces by hand
- 8" x 4" sheets come packaged in rolls of 60 sheets
- Purple colour sheets provide a Very Fine finish, and grey sheets provide an Ultra Fine finish

Model No. BP001	Model No. BP002
Very Fine Roll	Ultra Fine Roll
Price/Each \$54.00	Price/Each \$54.00



SCOTCH-BRITE™ PRODUCTION HAND PADS

- Higher rate of cut, longer life and better finish
- Use on aluminum, stainless steel, plastics, wood and fibreglass
- Ideal for paint preparations, surface blending and scuffing
- Comes in 6" x 9" pads which tear easily into 4 1/2" x 6" sheets

Model No. BP490
Price/Each \$1.31



HAND PAD HOLDERS

- Used with Scotch-Brite™ hand pads and roll material cut to 4" x 6" size

Model No. BP500
Price/Each \$8.68



AURORA HAND PADS

- Non-woven, synthetic fibres, bonded together with specially formulated resins and impregnated throughout the web with mineral grain creating an open, three dimensional structure
- Designed for light duty cleaning, polishing, scuffing, finishing and for heavy duty paint, rust and corrosion removal
- Can be used for dry scuffing and finishing or may be used with water or chemical solvents
- Flexible and strong
- 6" x 9"

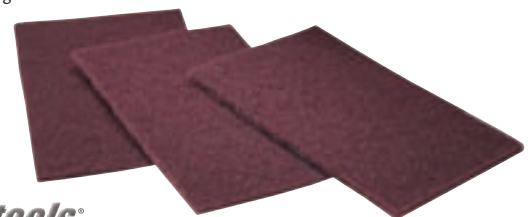

Model No.	Description	Finish	Price /Each
NU022	Tan heavy duty	Coarse	1.86
NU023	Green industrial	Scouring	0.83
NU024	Maroon GP	Medium	0.83
NU025	Grey ultra fine	Ultra-fine	0.96
NU026	White non-abrasive	Non-abrasive	1.15

ROLLS

Typical Applications

- Light deburring
- Cleaning
- Finishing
- Applying decorative finishes

Features & benefits

- Rolls may be cut for use in jitterbug sanding or on hand sanding applications
- Rolls have the durability for indexing machine applications

CLEAN & STRIP

Typical Applications

- Removal of paint and epoxy coating, surface rust and residue, corrosion, light weld splatter, dirt, mill scale and other similar surface contaminants
- Surface prep before coatings are applied
- Surface prep before welding; cleaning and conditioning afterwards
- Applying fine finishes

Features & benefits

- A web of strong synthetic fibres and quality abrasive, bonded together by a smear-resistant adhesive for cleaning, conditioning, and finishing a multitude of materials, quickly and easily with little loading

SCOTCH-BRITE™ CLEAN & FINISH ROLLS

- Used for final hand cleaning, blending and finishing
- Can be cut to desired length for oscillating sanders

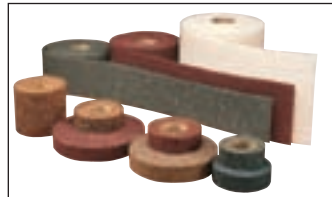

Model No.	Mfg. No.	Size	Colour	Finish	Price /Each
BP604	00264	4" x 30'	Maroon	Medium	104.00
BP612	00274	6" x 30'	Maroon	Medium	154.00
BP603	00265	4" x 30'	Maroon	Fine	78.70
BP611	00275	6" x 30'	Maroon	Fine	113.00
BP605	00266	4" x 30'	Maroon	Very fine	65.10
BP609	00270	4" x 30'	Grey	Very fine	65.10
BP613	00276	6" x 30'	Maroon	Very fine	96.10
BP608	69006	4" x 30'	Grey	Ultra fine	65.10
BP607	69009	4" x 30'	Grey	Super fine	65.10
BP606	69010	4" x 30'	White	Cleaning	65.10

MINI-MANDRELS

- Use with 1" x 1 1/2" Scotch-Brite™ material to fit tight areas
- Mandrel is 2 7/8" long with a 1/4" shank

Model No. BP504
Price/Each \$18.50



CUT 'N POLISH ROLLS

- Outlast and outperform emery cloth and utility rolls around angles, corners, odd shapes, and inside/outside diameters
- Used for general cleaning, deburring odd shapes and stropping pipe prior to soldering or welding
- Tan colour and medium finish

Model No. BP614 1" x 30' Roll
Price/Each \$41.20

Model No. BP615 2" x 30' Roll
Price/Each \$79.00



BEAR-TEX FAST CUT ROLLS

- Premium aluminum oxide grain provides clean cutting and long lasting
- Fast initial cut, less pressure needed
- Improved base adhesion, improved cut rate



Model No.	Colour	Grit	Size	Price /Each
NZ821	Tan	Medium	4" x 30'	168.00
NZ822	Maroon	Very Fine	4" x 30'	67.70
NZ823	Grey	Very Fine	4" x 30'	64.50

BEAR-TEX

Rapid strip discs and depressed center wheels

- Open web constructions provides fast cutting action with very little loading
- Follow difficult part profiles, easy cleaning of uneven surfaces
- Thick, strong, synthetic fibres and extra coarse grit
- Quick cleaning and conditioning of surfaces
- Silicon carbide abrasive, extra coarse
- Ideal for surface preparation, conditioning and cleaning, removal of rust, paint, weld spatter, etc.



Model No.	Size"	Max RPM	Qty /Pkg.	Price /Each
TYPE 1 - BEAR-TEX RAPID STRIP WHEELS				
NZ842	4 x 1/4	8000	25	15.10
NZ843	4 x 1/2	8000	25	15.10
NZ844	6 x 1/2	5500	15	24.40
TYPE 27 - BEAR-TEX RAPID STRIP CLEANING DISCS				
NS047	4 1/2 x 7/8	11000	10	17.30
NS136	7 x 7/8	8000	10	27.60

SCOTCH-BRITE™ CLEAN & STRIP DISCS (SILICON CARBIDE - EXTRA COARSE)

- Tough open web ideal for weld cleaning, paint and coatings removal
- Faster and safer than wire brushes



Model No.	Dia."	Max. RPM	Price /Each
BP252	4 x 1/2	6000	10.00
BP254	6 x 1/2	4000	16.50
BP255	8 x 1/2	3000	25.10

MANDRELS

- Furnished complete with washers to fit available disc sizes

Model No.	Mfg. No.	Size"	Price /Each
BP502	933	2	8.43
BP503	934	3 1/16	28.10



SURFACE BLENDING

Typical Applications

- Removing surface defects
- Removing light edge burrs, parting lines or flashing
- Removing rust, oxides, corrosion, paints and scale
- Cleaning molds
- Blending mill marks, tool marks, uneven edges and coated abrasive finish

Features & benefits

- Discs and belts perform well under a wide range of applications: from removing engine gaskets, and deburring of aluminum and steel, to finishing nickel alloy turbine blades

SCOTCH-BRITE™ COATING REMOVAL DISCS

Made for right angle tools from aggressive clean and strip web. Non-loading design ideal for removing rust and coatings.

- Hook and loop backing easily attaches to 3M disc pad holder
- Silicon carbide - extra coarse



Model No.	Dia."	Grit	Max. RPM	Price /Each
BP272	4 1/2	Extra coarse	12000	13.30
BP274	5	Extra coarse	10000	14.60
BP275	7	Extra coarse	6000	24.60

HOOK & LOOP SCOTCH-BRITE™ SURFACE CONDITIONING DISCS

Scotch-Brite™ surface conditioning discs are best for finishing, cleaning and light deburring on flat metal surfaces. Attach and remove easily to 3M hook & loop back up pads.

Used with the following hand tools:

- Right angle
- Random orbital
- Dual action



Model No.	Dia."	Grit	Colour	Max. RPM	Price /Each
BP357	2	Coarse	Brown	23 000	1.52
BP359	2	Medium	Maroon	23 000	1.32
BP362	2	Very Fine	Blue	23 000	1.32
BP363	3	Coarse	Brown	20 000	2.70
BP365	3	Medium	Maroon	20 000	2.98
BP367	3	Very Fine	Blue	20 000	2.70
BP376	4	Coarse	Brown	13 000	3.45
BP380	4	Very Fine	Blue	13 000	3.37
BP369	4 1/2	Coarse	Brown	13 000	4.08
BP371	4 1/2	Medium	Maroon	13 000	3.65
BP381	5	Coarse	Brown	10 000	4.72
BP383	5	Medium	Maroon	10 000	3.92
BP386	5	Very Fine	Blue	10 000	3.92
BP388	7	Coarse	Brown	6000	8.13
BP390	7	Medium	Maroon	6000	5.95
BP392	7	Very Fine	Blue	6000	6.62

HOOK & LOOP DISC PAD HOLDERS

For use with 3M Scotch-Brite™ surface conditioning and coating removal discs.

Model No.	Size"	Shank	Max. RPM	Price /Each
SHANK MOUNTED DISC PAD HOLDERS				
BP207	2	1/4"	23 000	9.13
BP208	3	1/4"	20 000	11.60
BP209	4	1/4"	13 000	12.90
BP206	5	5/16"-24	10 000	37.30
HUB MOUNTED DISC PAD HOLDERS				
BP199	4	5/8"-11	13 000	36.50
BP201	4 1/2	5/8"-11	13 000	36.50
BP202	5	5/8"-11	10 000	36.50
BP204	7	5/8"-11	6000	36.50



BP206



BP199

SCOTCH-BRITE™ DISCS

Premium Scotch-Brite™ surface conditioning non-woven web provides a burr-free decorative finish.

Removes grind marks, rust and coatings.



Model No.	Dia."	Grit	Colour	Price /Each
ROLOCTM				
BP396	2	Coarse	Brown	1.23
BP397	2	Medium	Maroon	1.23
BP398	2	Very Fine	Blue	1.23
BP400	3	Coarse	Brown	2.48
BP401	3	Medium	Maroon	2.48
BP403	3	Very Fine	Blue	2.48
ROLOCTM TSM				
BP404	2	Coarse	Brown	1.53
BP405	2	Medium	Maroon	1.53
BP406	2	Very Fine	Blue	1.53
BP407	3	Coarse	Brown	3.07
BP408	3	Medium	Maroon	3.07
BP409	3	Very Fine	Blue	3.07

ROLOCTM DISC PADS

Rubber back-up pads are available in different diameters and degrees of hardness for varying grinding applications. Pads are internally threaded to receive any standard 1/4"-20 thread shaft.



Model No.	Size"	Max. RPM	Hardness	Price /Each
BP008	2	25 000	Medium	21.30
BP005	2	25 000	Hard	19.50
BP009	3	18 000	Medium	23.80
BP006	3	20 000	Hard	23.80

ROLOCTM TSM DISC PADS

For use with Roloc™ TSM grinding discs and screw on abrasive discs.



Model No.	Size"	Max. RPM	Hardness	Price /Each
BP517	2	25 000	Medium	27.50
BP516	2	25 000	Hard	28.80
BP518	3	20 000	Hard	33.90

1/4" THREADED SHAFTS

- Needed with all Roloc™ disc pads

Model No. BP013 Price/Each \$3.77

ABRASIVES

BUFF & BLEND® PRODUCTS

These products are made from an open structure of non-woven fibres impregnated with abrasive particles held together by resin to form a loose webbing. Buff & Blend® products are designed for light duty removal of rust, oxidation and coatings (including paint), without affecting the base material. They are not intended for use on sharp edges or burrs.

GP MATERIAL

- Flexible and conformable
- GP provides a high rate of cut

SOCATT® DISCS

Model No.	Size"	Grit	Price /Each
VU676	2	Medium	1.43
VU677	2	Fine	1.34
VU678	2	Very Fine	1.34
VU679	3	Medium	2.32
VU680	3	Fine	2.09
VU681	3	Very Fine	2.09

HP MATERIAL

- Durable and aggressive
- Recommended starting point for deburring applications

Model No.	Size"	Grit	Price /Each
VU697	6 x 1/2	Very Fine	3.68
VU705	8 x 1/2	Very Fine	6.10

SCOTCH-BRITE EXL™ ROLOC™ UNITIZED WHEELS

- Strong, efficient products for edge deburring and finishing
- Used with 3M Roloc+ holder pads on a straight shaft or right angle tool

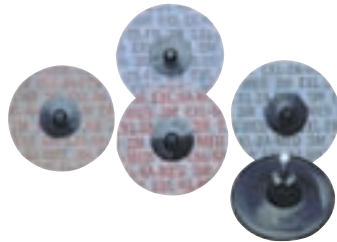

Model No.	Grit	Finish	Size"	Max. RPM	Price /Each
NW069	6A	Medium	2	22100	5.18
NW070	2A	Medium	2	22100	4.32
NW071	2S	Fine	2	22100	4.32
NW072	6A	Medium	3	15100	9.13
NW073	2A	Medium	3	15100	7.60
NW074	2S	Fine	3	15100	7.62



SURFACE CONDITIONING DISCS

These products provide a more compact structure of non-woven fibres than Buff & Blend® products. Surface conditioning products have a woven fabric (Scrim) imbedded in the nylon structure to provide additional strength and durability for edge work, deburring and efficient blending of all metal types.

FE MATERIAL

- High initial and extended rate of cut
- Very flexible with high edge durability
- Effective on both flat and contoured surfaces



SOCATT® DISCS

Model No.	Size"	Grit	Price /Each
NP136	2	Coarse	1.45
NW105	2	Medium	1.45
NP137	2	Very Fine	1.45
NW104	3	Coarse	2.73
NP131	3	Medium	2.73
NP132	3	Very Fine	1.43



LOCKIT® DISCS

Model No.	Size"	Grit	Price /Each
NP138	2	Coarse	1.45
NP139	2	Medium	1.45
NP140	2	Very Fine	1.45
NP133	3	Coarse	2.73
NP134	3	Medium	2.73
NP135	3	Very Fine	2.73

HOLDER PADS

- With mandrel



FOR SMALL DIAMETER SOCATT® DISCS

Model No.	Dia."	Density	Price /Each
VU601	2	Soft	17.68
VU602	2	Medium	16.97
VU603	2	Firm	20.20
VU604	3	Soft	21.53
VU605	3	Medium	19.62
VU606	3	Firm	23.37

FOR SMALL DIAMETER LOCKIT® DISCS

Model No.	Dia."	Density	Price /Each
NU294	2	Soft	19.50
VU611	2	Medium	16.97
VU612	2	Firm	20.20
VU613	3	Soft	21.53
VU614	3	Medium	19.62

THE INDESTRUCTIBLE!

Model TYB497
See page 1365

- ✓ Will not break, bend or split even after repeated overstrikes
- ✓ Ergonomic rubber grip absorbs impact, reducing user fatigue

3 YEAR LIMITED WARRANTY
 3 YEAR LIMITED WARRANTY

SCOTCH-BRITE™ SURFACE CONDITIONING FILE BELTS

Premium Scotch-Brite™ surface conditioning non-woven web.

Designed for:

- Cleaning
- Finishing
- Light deburring

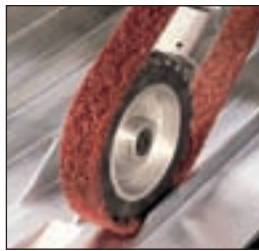

Recommended Operating Speeds:

Generally, low speeds are recommended for generating very uniform satin finishes, finishing aluminum alloys without lubricants, and woodworking applications. Higher speeds are recommended when removing imperfections prior to buffing. High belt speed will result in faster cut along with finer finishes.

Application	Recommended SFPM*
Decorative finishing	500-3000
Wood sanding	1200-2700
Deburring	5000-6500

Application	Recommended SFPM*
Cleaning and conditioning	2000-5000
Oxide removal	4500-6500

*Surface feet per minute

Model No.	Size"	Colour	Finish	Price /Each
BP069	1/4 x 24	Blue	Very fine	4.93
BP068	1/4 x 24	Maroon	Medium	4.93
BP067	1/4 x 24	Brown	Coarse	4.93
BP063	1/2 x 18	Blue	Very fine	7.22
BP062	1/2 x 18	Maroon	Medium	7.22
BP061	1/2 x 18	Brown	Coarse	7.22
BP066	1/2 x 24	Blue	Very fine	7.62
BP065	1/2 x 24	Maroon	Medium	7.62
BP064	1/2 x 24	Brown	Coarse	7.62
BP076	3/4 x 18	Blue	Very fine	10.00
BP075	3/4 x 18	Maroon	Medium	10.00
BP074	3/4 x 18	Brown	Coarse	10.00
BP060	1 x 48	Blue	Very fine	17.00
BP073	3 x 24	Maroon	Medium	27.90
BP071	3 1/2 x 15	Maroon	Medium	31.50
BP070	3 1/2 x 15	Brown	Coarse	31.50

BUFFING WHEELS

#60 Soft Cotton Wheels: 100% cotton 60/60 threads per square inch unbleached. For finishing stainless steel, brass, aluminum, gold, silver, chrome and wood.

#80 Cotton Buffing Wheels: 100% unbleached cotton 86/80 threads per square inch. For finishing brass, stainless steel, aluminum, bronze and cast iron.

Sisal Buffing Wheels: Made of sisal cloth #64 and cotton. 6 ply sisal/4 ply cotton. For aggressive buffing and polishing of steel, cast aluminum, iron, brass and bronze. Also excellent for deburring, breaking sharp edges in casting and removing stains, abrasive belt lines and light die marks.



Model No.	Dia."	Arbor"	Ply	Stitching	Price/Each
#60 SOFT COTTON WHEELS					
TD164	6	1/2	20	1/4" Spiral Sewn	34.80
TD167	6	1/2	25	Loose Style	20.90
TT161	6	1/2	36	1/2" Square Sewn	35.60
TD165	8	5/8	20	1/4" Spiral Sewn	36.20
TD168	8	5/8	25	Loose Style	20.20
TT150	10	5/8	20	1/4" Spiral Sewn	40.80
TT151	10	5/8	25	Loose Style	28.40
#80 COTTON BUFFING WHEELS					
TT152	6	1/2	20	1/4" Spiral Sewn	29.70
TT153	6	1/2	25	Loose Style	19.80
TT154	8	5/8	20	1/4" Spiral Sewn	35.20
TT155	8	5/8	25	Loose Style	25.60
TT156	10	5/8	20	1/4" Spiral Sewn	41.20
SISAL BUFFING WHEELS					
TT158	6	1/2	6 Sisal/4 Cotton	1/4" Spiral Sewn	38.70
TT159	8	5/8	6 Sisal/4 Cotton	1/4" Spiral Sewn	50.20
TT160	10	5/8	6 Sisal/4 Cotton	1/4" Spiral Sewn	52.90

SCOTCH-BRITE™ FLAP BRUSHES



- Heavy duty brush excellent for removing handling marks and surface imperfections
- Available on 1/4" shaft (CPFB-S) or Roloc+ attachment system (CPFB-R)

CPFB-R & CPFB-S

Model No.	Size"	Max. RPM	Grit	Price /Each
NW061	2 x 1 x 1/4	12000	Medium	18.20
BP446	3 x 1 3/4 x 1/4	8500	Medium	32.80

CFFB-R & CFFB-S

- Ideal for decorative finishes and light deburring applications
- Available on 1/4" shaft (CFFB-S) or Roloc+ attachment system (CFFB-R)

Model No.	Size"	Max. RPM	Grit	Price /Each
NS702	3 x 1 3/8	8000	Coarse	30.70
BP442	3 x 1 3/4 x 1/4	8500	Coarse	33.70
NS701	3 x 1 3/4 x 1/4	8500	Fine	33.70

COMBI WHEELS

- Made of alternating flaps of coated abrasive and Scotch-Brite™ web
- Aggressive cuts and fine finishes



Model No.	Grit	Size"	Max. RPM	Price /Each
NW066	80	3 x 1 3/4 x 1/4	8000	35.10
NW067	P120	3 x 1 3/4 x 1/4	8000	35.10
NW068	P180	3 x 1 3/4 x 1/4	8500	35.10

POLISHING & BUFFING WHEEL COMPOUNDS

For use with buffing wheels. All bars are: 2" x 2" x 10" except jewelers rouge: 1 1/4" x 1 1/4" x 6".



Model No.	Bar Type	Description	Price /Each
TT143	Black	Coarse, fast cutting bar for removal of rust and scale from iron and steel	24.80
TT144	Brown Tripoli	General purpose bar for buffing brass and aluminum	13.00
TT149	Green	For fine stainless steel and other metals, general purpose	30.20
TT218	White Rouge	Provides a bright luster to stainless steel, aluminum, iron, chrome and nickel surfaces	24.80
TT219	Red Jewelers Rouge	Enhances luster of buffed precious metals, gold, sterling, silver, platinum etc.	22.90
TT220	General Purpose	All round general purpose buffing compound	18.40

DEBURRING & MULTI-FINISHING WHEELS

Typical Applications

- Burr and flashing removal
- Surface roughness reduction
- Blending weld areas on stainless steel
- Blending scratch patterns
- Weld polishing
- Removing rust and oxides
- Applying decorative finishes including antique patterns

Features & benefits

- Formed by wrapping and bonding web material impregnated with abrasive grain and resin around a center core
- Offers a wide range of uses from heavy burr removal to cleaning rust and oxides

SCOTCH-BRITE™ MULTI-FINISHING WHEELS

Produces uniform grain finishes on stainless steel and other metals.

- Highly conformable
- Tough enough to finish edges and welds



Model No.	Grit	Finish	Size"	Max. RPM	Price /Each
BP715	2S	Coarse	6 x 1 x 1	6000	60.50
BP717	2S	Medium	6 x 1 x 1	6000	60.50
BP718	2S	Coarse	6 x 2 x 1	6000	94.20
BP720	2S	Medium	6 x 2 x 1	6000	94.20
BP721	2S	Coarse	8 x 1 x 3	4500	85.90
BP723	2S	Medium	8 x 1 x 3	4500	85.90

SCOTCH-BRITE™ EXL DEBURRING WHEELS

Use to clean, finish, blend, deburr or polish all types of metals, composites and glass.



Model No.	Grit	Finish	Size"	Max. RPM	Price /Each
BP694	8A	Medium	6 x 1/2 x 1	6000	65.27
BP695	8S	Fine	6 x 1/2 x 1	6000	65.30
BP696	9S	Fine	6 x 1/2 x 1	6000	65.30
BP690	8A	Medium	6 x 1 x 1	6000	86.60
BP692	8S	Fine	6 x 1 x 1	6000	86.60
BP693	9S	Fine	6 x 1 x 1	6000	86.60
BP697	8A	Medium	8 x 1 x 3	4500	111.00
BP698	8S	Fine	8 x 1 x 3	4500	111.00
BP700	9S	Fine	8 x 1 x 3	4500	111.00
BP704	8A	Medium	8 x 2 x 3	4500	188.00
BP705	8S	Fine	8 x 2 x 3	4500	188.00
BP706	9S	Fine	8 x 2 x 3	4500	188.00

SCOTCH-BRITE™ EXL UNITIZED DEBURRING WHEELS



Excellent for deburring and polishing a wide range of metals, plastics and composites.

- Cool running allows more pressure to be applied
- Cleaner than buffs and compounds
- Eliminate danger of loose-flying wires

Model No.	Grit	Finish	Size"	Max RPM	Price /Each
BP737	2A	Medium	1 x 1 x 3/16	25 100	4.58
BP738	2S	Fine	1 x 1 x 3/16	30 100	4.58
BP739	6A	Medium	1 x 1 x 3/16	35 100	4.78
BP740	6S	Fine	1 x 1 x 3/16	35 100	4.79
BP741	8A	Coarse	1 x 1 x 3/16	35 100	5.50
BP742	8A	Medium	1 x 1 x 3/16	35 100	5.50
BP743	2A	Medium	3 x 1/4 x 3/8	12 100	8.12
BP744	2S	Fine	3 x 1/4 x 3/8	12 100	7.37
BP745	4A	Fine	3 x 1/4 x 3/8	18 100	7.98
BP746	6A	Medium	3 x 1/4 x 3/8	18 100	8.82
BP747	6S	Fine	3 x 1/4 x 3/8	18 100	8.82
BP748	8A	Coarse	3 x 1/4 x 3/8	18 100	9.72
BP749	8A	Medium	3 x 1/4 x 3/8	18 100	9.72

SCOTCH-BRITE™ HIGH STRENGTH DISCS (ALUMINUM OXIDE)

- Very conformable discs
- Ideal for light deburring, cleaning and finishing



Model No.	Dia."	Grade	Max. RPM	Price /Each
NW051	6 x 1/4	Very Fine	4000	3.08
NW052	6 x 1/2	Medium	4000	6.10
NW053	6 x 1/2	Very Fine	4000	3.12
NW054	8 x 1/2	Medium	3000	8.92
NW055	8 x 1/2	Very Fine	3000	4.85

SCOTCH-BRITE™ CUT & POLISH WHEELS

Heavy-duty wheels for aggressive blending and finishing.

- Produce uniform results quickly and easily
- Replace rubber bonded wheels, set-up wheels and lap wheels

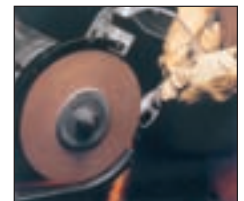

Model No.	Grit	Finish	Size"	Max. RPM	Price /Each
BP680	7A	Coarse	6 x 1 x 1	6000	135.00
BP682	7A	Medium	6 x 1 x 1	6000	135.00
BP681	7A	Fine	6 x 1 x 1	6000	135.00

WHEEL ACCESSORIES

Flange Adaptor No. 5: For use with 6" wheels. Telescoping wheel adaptors 1" and 1/2" wide to reduce 1" wheel cores to fit 5/8". Must be used with side flanges.



Model No.	Size"	Price /Each
FLANGE ADAPTOR NO. 5		
NW080	1 x 1/2 x 1/2	8.43
NW081	1 x 1 x 1/2	2.20

MANDRELS

Designed for use with Scotch-Brite™ unitized wheels.

Model No.	Size"	Max RPM	Price /Each
BP505	2 1/16 x 1/4 x 3/4	22200	8.88
NW076	1 3/4 x 1/4 x 1/2	35200	9.30
BP508	1 3/4 x 1/4	18200	17.90



ECONOMY BRUSHES

- An economic alternative to the high-value Osborn® brand
- Geared toward light industrial and DIY users
- Selected from the fastest movers in the Osborn® line to provide a complete selection of quick-turning products
- Standard arbor sizes or shanks
- Power brushes with plain arbor holes come packaged with adapters for common drive sizes
- High-speed thread adapters are included in the Osborn® economy line to fit most threaded drives
- All power brushes are display packaged



CRIMPED WIRE WHEEL BRUSHES - NARROW FACE
INCLUDES 1/2" AND 5/8" ADAPTERS

Model No.	Mfg. No.	Brush Dia."	Arbor Hole"	Fill Dia."	Type	Face Width"	Max. RPM	Price /Each
NU096	99009	6	2	0.014	Steel	5/8	6000	13.20
NU097	99010	8	2	0.014	Steel	5/8	4500	19.70



CRIMPED WIRE WHEEL BRUSHES - WIDE FACE
INCLUDES 1/2" AND 5/8" ADAPTERS

Model No.	Mfg. No.	Brush Dia."	Arbor Hole"	Fill Dia."	Type	Face Width"	Max. RPM	Price /Each
NU103	99022	6	2	0.014	Steel	1 1/4	6000	28.50
NU104	99023	8	2	0.014	Steel	1 1/2	4500	47.80



CRIMPED WIRE WHEEL BRUSHES - MEDIUM FACE
INCLUDES 1/2" AND 5/8" ADAPTERS

Model No.	Mfg. No.	Brush Dia."	Arbor Hole"	Fill Dia."	Type	Face Width"	Max. RPM	Price /Each
NU098	99012	6	2	0.008	Steel	3/4	6000	25.20
NU099	99015	6	2	0.014	Steel	3/4	6000	19.90
NU100	99016	7	2	0.014	Steel	3/4	6000	26.60
NU101	99013	8	2	0.008	Steel	3/4	6000	36.10
NU102	99017	8	2	0.014	Steel	3/4	4500	32.90



HIGH SPEED STRINGER BEAD KNOT WIRE WHEEL BRUSH

Model No.	Mfg. No.	Brush Dia."	Arbor Hole"	Fill Dia."	Type	Face Width"	Max. RPM	Price /Each
NU105	99083	5	5/8-11	0.02	Steel	3/16	12000	18.10
NU106	99089	6	5/8-11	0.02	Stainless	1/4	12000	43.30
NU107	99084	6	5/8-11	0.02	Steel	1/4	12000	16.30
NU108	99086	6 1/2"	5/8-11	0.02	Steel	3/16	12000	16.70



KNOT WIRE END BRUSH

Model No.	Mfg. No.	Brush Dia."	Fill Dia."	Stem Dia."	Type	Max. RPM	Price /Each
NU109	99098	3/4	0.014	1/4	Steel	20000	9.22
NU110	99099	3/4	0.02	1/4	Steel	20000	6.70
NU111	99100	1	0.012	1/4	Steel	20000	10.60
NU112	99101	1	0.014	1/4	Steel	20000	8.63
NU113	99102	1	0.02	1/4	Steel	20000	8.26
NU114	99103	1	0.014	1/4	Stainless	20000	17.40

ATB™ NYLON ABRASIVE COMPOSITE FLEXIBLE WHEEL BRUSHES

- Brushes with long trim and moderate density offer long brush life, less filament breakage and uniform distribution of filaments
- Maximum RPM: 3600
- Ideal for applications requiring a high degree of conformability
- **Applications:** Turbine blades, indexable cutting tool inserts, cam shafts, machined parts, and edge radiusing



Brush Dia."	Grit	Filament Diameter (mm)	Arbor Hole"	Face Width"	Trim Length"	Model No.	Price /Each
6	80	0.04	2	1	1 1/4	NT733	86.40
6	80	1.14 x 2.28	2	1	1 1/4	NT734	118.00
6	120	0.028	2	1	1 1/4	NT735	86.40
6	120	0.04	2	1	1 1/4	NT736	86.40
6	180	0.035	2	1	1 1/4	NT737	89.90
6	320	0.022	2	1	1 1/4	NT738	89.90
8	80	1.14 x 2.28	1 1/4	1	2 1/4	NT739	173.00
8	80	0.04	1 1/4	1	2 1/4	NT740	128.00
8	120	0.04	1 1/4	1	2 1/4	NT741	128.00
8	180	0.035	1 1/4	1	2 1/4	NT742	128.00
8	320	0.022	1 1/4	1	2 1/4	NT743	128.00

BRUSHES



END BRUSHES

Especially suited for use on portable air and electric tools, CNC and robotic equipment, the end brush is designed for work where space limitations are a factor. In most applications, higher speeds (up to 25 000 RPM) are required for effective brushing action. Osborn® end brush fill materials include carbon and stainless steels, brass, natural fibre, abrasive nylon, and TY® elastomer encapsulated wire.

OD - OUTSIDE DIAMETER

Standard Osborn® end brushes are made with outside diameters from 3/16" through 3". For larger surfaces or "surround" applications, multiple brushes may be clustered. As a guide, add 1/8" to brush O.D. to get overall O.D.

T - TRIM LENGTH

Shorter brush section provides stiffness and faster cutting. Longer filaments have more flexibility for irregular surfaces.

OAL - OVERALL LENGTH

Distance from end of brush part to end of shank.

S - SHANK DIAMETER

All standard end brushes have 1/4" diameter shank. Miniature end brushes have 1/8" diameter shank.



CRIMPED WIRE END BRUSHES

- Engineered to operate at high speeds
- **Applications:** Rubber and Plastic Mold Cleaning/Cleaning Pipe I.D./Removing Rust, Weld Scale and Spatter/Cleaning Castings/Burr Removal/Rubber Flash Removal/Carbon Removal/Spot Facing/Cleaning and Finishing Recessed Areas



JACKSONLEA

WITH 1/4" SHANK

Brush Dia."	O.A. Length"	Wire Gauge"	Trim Length"	Max RPM	Model No.	Price /Each
STEEL						
1/2	2 3/4	0.0104	1	25 000	BX374	7.92
1/2	2 3/4	0.02	1	25 000	BX375	7.62
3/4	2 3/4	0.02	1	20 000	BX378	11.60
STAINLESS						
1/2	2 3/4	0.0104	1	25 000	BX359	13.10
1/2	2 3/4	0.014	1	25 000	BX360	11.80

CRIMPED WIRE END BRUSHES

- Ideal for flash, scale, rust, corrosion and paint removal
- Softer impact and more flexible than knotted brushes
- Great tool for polishing, edge blending and surface preparation
- Efficient, light cleaning of small hard-to-reach surface areas



Brush Dia."	Fill Dia."	Shank Size"	Fill Length"	Max RPM	Model No.	Price /Each
STEEL						
1/2	0.005	1/4	1	20 000	NU447	9.45
1/2	0.014	1/4	1	20 000	TT316	9.30
3/4	0.005	1/4	1	20 000	NU449	10.30
1	0.005	1/4	1	20 000	NU451	13.70
1	0.014	1/4	1	20 000	TT317	9.94
STAINLESS						
1/2	0.005	1/4	1	20 000	NU448	15.60
3/4	0.014	1/4	1	20 000	TC135	10.00
3/4	0.006	1/4	1	20 000	NU450	20.20
1	0.005	1/4	1	20 000	NU452	25.20

KNOT WIRE END BRUSHES

- Ideal for flash, scale, rust, corrosion and paint removal
- Great tool to reach into holes and hard to reach areas
- More aggressive brushing action than crimped brushes
- Low flexibility knotted wire for high impact brushing



Brush Dia."	Fill Dia."	Shank Size"	Fill Length"	Max RPM	Model No.	Price /Each
STEEL						
1/2	0.014	1/4	1	22 000	NU456	20.50
3/4	0.014	1/4	1	22 000	NU457	14.40
1	0.012	1/4	1	25 000	MLP989	16.50
1	0.014	1/4	1	25 000	TT300	15.00
1	0.020	1/4	1	25 000	TC134	14.50
STAINLESS						
1	0.012	1/4	1	25 000	NU453	25.70
1	0.014	1/4	1	25 000	NU454	28.30
1	0.020	1/4	1	25 000	NU455	28.10

KNOT WIRE END BRUSHES

Rugged brushing tools designed with the finest wire to offer efficient usage for a wide variety of tough cleaning and maintenance applications; can be used on CNC equipment. Available with steel, stainless steel and brass wire. Certain styles are available in clamshell packaging.

- **Applications:** Spot Cleaning or Facing/Removal of Slag, Rust or Scale/Cleaning Pipe I.D./Deburring or Flash Removal/Cleaning of Dies, Moulds and Tooling/Pipeline Cleaning



JACKSONLEA

WITH 1/4" SHANK

Brush Dia."	O.A. Length"	Wire Gauge"	Trim Length"	Max RPM	Model No.	Price /Each
STEEL						
1/2	2 3/4	0.014	1 1/8	22 000	BX350	17.60
3/4	2 3/4	0.014	1 1/8	20 000	BX353	17.40
1	2 3/4	0.014	1	20 000	BX357	19.50
STAINLESS						
1/2	2 3/4	0.014	1 1/8	22 000	BX481	17.60
3/4	2 3/4	0.014	1 1/8	20 000	BX484	19.60
1	2 3/4	0.014	1	20 000	BX487	23.80

SCUF-GUARD COATED BRUSHES

- Made with a durable elastomer layer on the cup to help prevent accidental scratches or markings on the work surface during operation
- Stainless steel wire



JACKSONLEA

Dia."	Brush Length"	O.A. Length"	Fill Dia."	Trim Length"	Max RPM	Model No.	Price /Each
1/2	1 1/8	2 3/4	0.006	1 1/8	22 000	BX364	31.00
1/2	1 1/8	2 3/4	0.014	1 1/8	22 000	BX366	25.30
3/4	1 1/8	2 3/4	0.006	1 1/8	20 000	BX367	35.10
3/4	1 1/8	2 3/4	0.014	1 1/8	20 000	BX369	26.30
1	1	2 3/4	0.006	1 1/8	20 000	BX370	43.30
1	1	2 3/4	0.014	1	20 000	BX372	34.80

AH - ARBOR HOLE

Osborn® brushes are made with a variety of standard sizes which can easily be adapted to fit any standard spindle.

OD - OUTSIDE DIAMETER

Standard Osborn® wheel brushes are made with outside diameters from about one inch to almost two feet. Generally, the largest diameter that suits your work space and machine speed will be most efficient.

ID - INSIDE DIAMETER

Assuming a fixed O.D., increasing the I.D. produces a stiffer, less flexible brush.

T - TRIM LENGTH

Shorter trim makes a stiff, fast cutting brush. Longer trim makes a more flexible brush for irregular surfaces.

F - FACE WIDTH

Standard face widths range from extremely narrow to several inches wide. Many styles can be mounted in multiple.

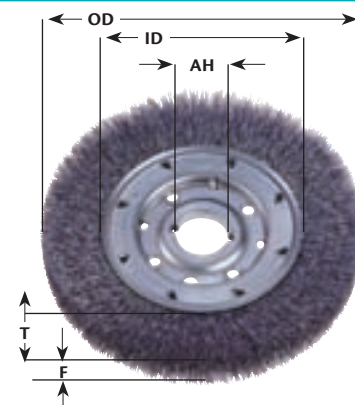

CRIMPED WIRE WHEEL BRUSHES

- Can be mounted horizontally or vertically
- Highly flexible, ideal for light to medium duty surface preparation on irregular surface
- Offered a variety of style from aggressive material removal to surface conditioning and polishing

NARROW FACE

- More flexible than the wide and medium style
- Can be mounted in multiples
- To be used with a straight grinder, a bench/pedestal grinder or a right angle grinder
- **Application:** Deburring and cleaning narrow areas, producing antique finishes, rust and paint removal



Brush Dia."	Arbor Hole"	Wire Gauge"	Trim Length"	Face Width"	Max RPM	Model No.	Price /Each
STEEL							
6	1 1/4	0.014	1 1/8	5/8	6000	BW882	23.40
8	1 1/4	0.014	1 1/2	5/8	4500	BW886	39.10
10	1 1/4	0.014	2 1/2	5/8	3600	BW888	51.20
STAINLESS							
6	1 1/4	0.014	1 1/8	5/8	6000	BW899	58.20
8	1 1/4	0.014	3/4	1/2	4500	BW900	70.10

WIDE FACE

- Maximum wire density and aggression, providing fast, efficient brushing on production work and general maintenance job
- To be used with a bench/pedestal grinder
- **Application:** Deburring, rust removal, surface finishing and cleaning



Brush Dia."	Arbor Hole"	Wire Gauge"	Trim Length"	Face Width"	Max RPM	Model No.	Price /Each
STEEL							
4 1/4	2	0.0118	3/4	1	6000	BW964	65.30
6	2	0.0118	1	1 1/4	6000	BW968	89.90
8	2	0.0118	1 1/2	1 1/2	4500	BW980	119.00
10	2	0.0118	2 1/8	2	3600	BW983	219.00
STAINLESS							
8	2	0.0118	1 1/2	1 1/2	4500	BX017	196.00

CRIMPED WIRE WHEEL BRUSH WITH 1/4" SHANK

- Uniform dense fill
- Can be used of hand or on a drill press for internal and external cleaning and deburring
- **Application:** Rust, scale, paint, dirt and weld spatter removal



Brush Dia."	Shank Dia."	Wire Gauge"	Trim Length"	Max RPM	Model No.	Price /Each
STEEL						
1 1/2	1/4	0.008	0.281	25 000	BW737	12.10
2	1/4	0.014	0.438	25 000	BW743	13.80
3	1/4	0.014	0.75	25 000	BW753	13.80
STAINLESS						
1 1/2	1/4	0.012	0.281	25 000	BW741	15.60
2	1/4	0.014	0.438	25 000	BW746	21.90
3	1/4	0.014	0.75	25 000	BW756	26.40

MEDIUM FACE

- Greater fill density and more aggressive brushing action
- Can be adaptable to multiple mounting for brushing wider areas
- To be used with a bench/pedestal grinder
- **Application:** Edge blending, deburring, rust removal, surface finishing and cleaning



Brush Dia."	Arbor Hole"	Wire Gauge"	Trim Length"	Face Width"	Max RPM	Model No.	Price /Each
STEEL							
6	2	0.0118	1	7/8	6000	BW996	45.70
8	2	0.0118	1 1/2	5/8	4500	BX006	64.70
10	2	0.0118	2	1 1/4	3600	BX022	107.00
STAINLESS							
6	2	0.0118	1	7/8	6000	BX040	78.80
8	2	0.0118	1 1/2	5/8	4500	BX038	105.00

CENTERING BUSHINGS

- Use only one
- For use with Osborn® brushes only



Model No.	Fits AH"	Reduces to"	Price /Each
BY231	1/2	1/4	0.63
BY232	1/2	3/8	0.63
BY235	5/8	1/4	0.63
BY234	5/8	3/8	0.63
BY233	5/8	1/2	0.63

SMALL DIAMETER CRIMPED WIRE WHEEL BRUSH

- Specially designed for effective brushing operations on internal surfaces and other hard to reach areas
- Can be mounted singly or in multiples, directly onto the shaft of a portable tool
- To be used with: straight grinder, right angle air die grinder, die grinder, drill.
- **Applications:** Deburring, ID cleaning, rust, scale, carbon and corrosion removal



Brush Dia."	Arbor Hole"	Wire Gauge"	Trim Length"	Face Width"	Max RPM	Model No.	Price /Each
STEEL							
1 1/2	3/8	0.014	3/8	7/32	20 000	BB458	6.83
2	1/2	0.014	1/2	1/4	20 000	BB470	8.25
3	1/2	0.014	1	1/4	20 000	BW680	10.50
STAINLESS							
1 1/2	3/8	0.014	3/8	7/32	20 000	BB437	9.31
2	1/2	0.014	1/2	1/4	20 000	BB440	11.10
3	1/2	0.014	1	1/4	20 000	BW700	16.20



BRUSHES

MAJOR WIRE WHEEL BRUSHES

- Top grade wire for long service life and reduced wire breakage
- Efficient, light cleaning of off-hand work pieces
- Good for edge blending and surface preparation

FELTON BRUSHES



Brush Dia."	Fill Dia."	Arbor Size"	Face Width"	Max RPM	Model No.	Price /Each
STEEL						
4	0.014	1 1/8	7/8	6000	NU474	30.80
6	0.012	2	7/8	6000	NU475	32.70
6	0.014	2	1	6000	NU477	45.40
6	0.020	2	1	6000	NU478	45.40
8	0.005	2	7/8	4500	NU479	55.30
8	0.012	2	7/8	4500	NU480	45.40
8	0.012	2	1 1/4	4500	NU482	65.20
8	0.014	2	1 1/4	4500	NU483	63.20
6	0.014	2	7/8	6000	QM346	34.60
8	0.014	2	7/8	4500	QM404	43.30

COPPER CENTRE CRIMPED WIRE WHEELS

- Filled with high quality steel wire
- Used for deburring, stripping wire, removing rust, scale and corrosion or blending tool marks
- Can be used in singles or in multiples

FELTON BRUSHES



Brush Dia."	Fill Dia."	Arbor Size"	Face Width"	Max RPM	Model No.	Price /Each
STEEL						
1 1/2	0.005	3/8	1/4	20 000	NU486	12.90
2	0.005	3/8	3/8	20 000	NU487	11.50
2	0.012	3/8	3/8	20 000	NU488	11.40
2	0.014	1/2	3/8	20 000	NU489	10.90
2 1/2	0.012	1/2	1/2	20 000	NU490	8.86
3	0.014	3/8	5/8	20 000	NU491	10.70
3	0.012	1/2	5/8	20 000	NU492	9.98
3	0.014	1/2	5/8	20 000	NU493	11.50
3	0.020	1/2	5/8	20 000	NU494	13.60
4	0.012	1/2	5/8	20 000	NU495	16.60

CIRCULAR CRIMPED WIRE END BRUSHES

- Ideal for burr, weld scale, corrosion and paint removal
- Softer impact and more flexible than knotted brushes
- Efficient, light cleaning of small surfaces areas
- Great for cleaning pipes and grooves

FELTON BRUSHES



Brush Dia."	Fill Dia."	Shank Size"	Face Width"	Max RPM	Model No.	Price /Each
STEEL						
1 1/2	0.005	1/4	1/4	20 000	NU458	14.90
1 1/2	0.014	1/4	-	20 000	QM452	11.00
2	0.012	1/4	3/8	20 000	NU460	13.00
2	0.014	1/4	3/8	20 000	NU461	10.10
3	0.014	1/4	-	20 000	QM458	14.70
STAINLESS						
1 1/2	0.014	1/4	1/4	20 000	NU459	16.00
3	0.006	1/4	5/8	20 000	NU462	21.60
3	0.014	1/4	5/8	20 000	NU463	17.50
4	0.008	1/4	5/8	20 000	NU464	16.90

CIRCULAR KNOTTED WIRE END BRUSHES

- Ideal for burr, weld scale, corrosion and paint removal
- More aggressive brushing action than crimped brushes
- Reaches into corners and inside edges

FELTON BRUSHES



Brush Dia."	Fill Dia."	Shank Size"	Max RPM	Model No.	Price /Each
STEEL					
3 1/2	0.014	1/4	25 000	NU467	23.90
STAINLESS					
3 1/2	0.014	1/4	25 000	NU468	53.80

CRIMPED WIRE CONCAVE END BRUSHES

- Crimped wire wheel has a concave face to reach into corners
- Acts as an off-hand sweeping tool
- For use on drill presses for internal or external cleaning

FELTON BRUSHES



Brush Dia."	Fill Dia."	Shank Size"	Max RPM	Application Type	Model No.	Price /Each
1 1/2	0.012	1/4	20 000	Steel	NU469	10.40

METAL ADAPTOR FOR 1 1/4" & 2" ARBOR HOLE

- Slip fit adaptor
- Comes in pair



OSBORN

JACKSONLEA

Fits Arbor Hole"	Reduces to Arbor Hole"	Model No.	Price /Each
1 1/4	1/2	BY224	4.05
1 1/4	5/8	BY225	4.02
1 1/4	3/4	BY226	4.05
2	1/2	BY204	4.05
2	5/8	BY205	4.02
2	3/4	BY206	4.05
2	7/8	BY207	4.05
2	1	BY208	4.05
2	1 1/4	BY210	4.05
2	1 1/2	BY211	4.05

BRUSH DRIVE ARBOR

- For brushes up to 3" in diameter
- Design for use with a single brush only
- Not for use with non-brush perishable tool

OSBORN

JACKSONLEA



Diameter"	Overall Length"	Shank Dia."	Model No.	Price /Each
1/4	1 1/2	3/16	BY198	9.06
3/8	1 3/4	1/4	BY199	8.80
1/2	1 3/4	1/4	BY200	9.45
5/8	1 3/4	1/4	BY201	9.45

KNOT WIRE WHEEL BRUSHES

- The individual knot wire tufts of a knot wheel provide minimal flexibility for more aggressive brushing action
- Rugged knot-type construction provides high brush flexibility, more uniform results, maximum safety and efficient operation at high speeds
- Brushes larger than 6" should be mounted on stationary tables; those 6" and smaller can be mounted to stationary installations or attached to portable tools

STANDARD TWIST KNOT

- Aggressive, high impact action for severe application,
- To be used with straight grinders, bench and pedestal grinder or right angle grinder



STRINGER BEAD

- Tighter knot, fit into more recessed area
- To be used with straight grinders or right angle grinder



There are other wheel sizes,
wire sizes & arbor sizes
available for all brush types.

Different materials
are also available.

STRINGER BEAD

- Small width allows this brush to be used in recessed area such as welding junctions
- **Application:** Cleaning stringer bead welds



Brush Dia."	Arbor Hole"	Wire Gauge"	Trim Length"	Face Width"	Max RPM	Model No.	Price /Each
STEEL							
4 7/8	5/8-11NC	0.02	1	3/16	12 000	BX338	24.60
6 1/2	5/8-11NC	0.02	1 1/4	3/16	12 000	BX161	38.20
STAINLESS							
4 7/8	5/8-11NC	0.02	1	3/16	12 000	BX270	45.40
6 1/2	5/8-11NC	0.02	1 1/4	3/16	12 000	BX273	58.40

HIGH SPEED STEEL SMALL GRINDER, STRINGER BEAD

- Works aggressively, smoothly and efficiently on air or portable power tools
- **Application:** Bead scale removal



Brush Dia."	Arbor Hole"	Colour	Wire Gauge"	Trim Length"	Max RPM	Model No.	Price /Each
STEEL							
4	5/8-11NC	Steel	0.02	7/8	20 000	BX288	22.30
4	M-14 x 2.0	Red	0.02	7/8	20 000	BX284	24.20
STAINLESS STEEL							
4	5/8-11NC	Steel	0.02	7/8	20 000	BX311	38.10
4	M-14 x 2.0	Red	0.02	7/8	20 000	BX307	40.20

STANDARD TWIST KNOT WITH 1/4" SHANK

- Designed to operate at high speeds
- **Applications:** Maintenance and metal surface cleaning



Brush Dia."	Wire Gauge"	Trim Length"	Max RPM	Model No.	Price /Each
STEEL					
3	0.014	5/8	25 000	BX193	26.80
4	0.014	7/8	20 000	BX196	28.40
STAINLESS					
3	0.014	5/8	25 000	BX195	47.60
4	0.014	7/8	20 000	BX198	49.90

STANDARD TWIST KNOT

- **Application:** Removal of rubber flash, paint slag, scale, rust, surface contamination, weld cleaning, blending, finishing, deburring, descaling, pipeline cleaning and general cleaning



Brush Dia."	Arbor Hole"	Wire Gauge"	Trim Length"	Face Width"	Max RPM	Model No.	Price /Each
STEEL							
4	3/8	0.014	7/8	5/16	20 000	BX125	33.80
6	5/8-11NC	0.025	1 1/2	1/2	9 000	BX137	32.40
8	5/8	0.025	1 11/16	5/8	8 500	BX144	63.90
STAINLESS							
4	3/8	0.014	7/8	5/16	20 000	BX202	49.90
6	5/8-11NC	0.025	1 1/2	1/2	9 000	BX272	58.80

STANDARD TWIST KNOT HIGH SPEED STEEL SMALL GRINDER

- Works aggressively, smoothly and efficiently on air or portable power tools
- **Applications:** Cleans grooves, T-connections, weld beads and surface prep



Brush Dia."	Arbor Hole"	Colour	Wire Gauge"	Trim Length"	Max RPM	Model No.	Price /Each
STEEL							
4	5/8-11NC	Steel	0.02	7/8	20 000	BX305	26.60
4	M-14 x 2.0	Red	0.02	7/8	20 000	BX301	27.70
5	5/8-11NC	Steel	0.02	1	12 000	BX206	30.70
STAINLESS							
4	5/8-11NC	Steel	0.02	7/8	20 000	BX299	46.00
4	M-14 x 2.0	Red	0.02	7/8	20 000	BX295	43.20
5	5/8-11NC	Steel	0.02	1	12 000	BX207	75.90

WIRE WHEEL BRUSHES

- Narrow face for confined and hard to reach contact areas
- Low flex high impact aggressive brush action
- Perfect for expansion joints and filler welds
- For root and hot pass weld cleaning
- Customization available



Brush Dia."	Face Width"	Fill Dia."	Arbor Size"	Knot Type	No. of Knots	RPM	Model No.	Price /Each
STEEL								
4	3/16	0.020	5/8-11	Stringer	32	20 000	TT265	17.70
4-7/8	3/16	0.020	5/8-11	Stringer	48	12 500	TT271	22.20
5-7/8	3/16	0.020	5/8-11	Stringer	48	12 500	TC019	27.40
4	1/4	0.020	5/8-11	Cable	20	20 000	NU432	20.30
5	3/8	0.020	5/8-11	Cable	24	20 000	NU434	29.00
6	3/8	0.014	5/8-11	Cable	28	9 000	NU436	43.10
4	1/2	0.020	5/8-11	Standard	20	20 000	NU438	20.00
6	1/2	0.014	5/8-11	Standard	28	9 000	NU440	34.30
8	5/8	0.014	5/8-11	Standard	40	6 000	NU442	42.30
STAINLESS								
4	3/16	0.020	5/8-11	Stringer	32	20 000	TT270	28.20
4-7/8	3/16	0.020	5/8-11	Stringer	48	12 500	TT272	34.90
5-7/8	3/16	0.020	5/8-11	Stringer	48	12 500	TT273	42.00
4	1/4	0.020	5/8-11	Cable	20	20 000	NU433	36.20
5	3/8	0.020	5/8-11	Cable	24	20 000	NU435	30.80
6	3/8	0.014	5/8-11	Cable	28	9 000	NU437	51.80
4	1/2	0.020	5/8-11	Standard	20	20 000	NU439	34.30
6	1/2	0.014	5/8-11	Standard	28	9 000	NU441	54.60
8	5/8	0.014	5/8-11	Standard	40	6 000	NU443	71.50

BRUSHES

KNOTTED WIRE WHEEL SAUCER BRUSHES

- More aggressive brushing action than crimped brushes
- Ideal for burr, weld scale, corrosion and paint removal
- Reaches into corners and inside edges for a more effective clean



Brush Dia.™	Face Width™	Fill Dia.™	Arbor Size™	RPM	Model No.	Price /Each
STEEL						
4	1/2	0.020	5/8-11	20000	NU470	19.60
5	7/8	0.020	5/8-11	15000	NU472	34.30
STAINLESS						
S4	1/2	0.020	5/8-11	20000	NU471	30.30
S5	7/8	0.020	5/8-11	15000	NU473	46.60

AH - ARBOR HOLE

Most cup brushes are available with either plain or 5/8-11NC threaded arbor holes, while a few styles feature a hexagonal opening, and smaller sizes are fitted with a 1/4" shank.

OD - OUTSIDE DIAMETER

Standard Osborn® cup brushes are made in a range of outside diameters from 2" to 9". Generally, the largest diameter that suits your work space and machine speed will be most efficient.

T - TRIM LENGTH

The length of the fill material that extends beyond the metal cup or bridle. A short trim length provides a stiff, fast-cutting brush, while a longer trim length offers flexibility for dressing irregular surfaces.

R - ROW COUNT & ALIGNMENT

Cup brushes are available with one, two, or three rows of filaments or knots. Unless otherwise identified as "Stagger Row," multiple rows are parallel. Stagger row brushes provide more aggressive action.



CRIMPED WIRE CUP BRUSHES

Designed for light and medium-duty applications on a variety of high speed air and electric tools. Offers smooth, responsive cutting action at all speeds on a variety of jobs.

WITH 1/4" SHANK - LIGHT DUTY

- Offers light duty cleaning action on air tools or electric high-speed portable tools
- All brushes have a 1/4" shank



HIGH SPEED SMALL GRINDER

- Flat brushing
- Surface prep
- Medium duty cleaning of flat surfaces and edges
- Removal of burrs
- Cleaning flat or curved surfaces
- Cleaning edges or angles
- Welding cleanup



Brush Dia.™	Arbor Hole™	Trim Length™	Max RPM	Model No.	Price /Each
STEEL					
1 3/4	0.0118	1/2	13000	BX593	12.00
2 1/2	0.0104	5/8	4500	BX530	37.80
STAINLESS					
1 3/4	0.0118	1/2	13000	BX595	21.50
2 1/2	0.0104	5/8	4500	BX572	48.20

Brush Dia.™	Arbor Hole™	Wire Gauge™	Trim Length™	Max RPM	Model No.	Price /Each
STEEL						
2 3/4	5/8-11NC	0.014	1	14000	BX547	20.80
2 3/4	M-10 x 1.25	0.014	1	14000	BX544	21.60
2 3/4	M-14 x 2.0	0.014	1	14000	BX543	21.60
STAINLESS						
2 3/4	5/8-11NC	0.014	1	14000	BX574	34.40

3" BRIDLED CUP BRUSHES

- Aggressive tools for fast, heavy-duty cleaning and brushing of metal surfaces
- Removes carbon build up, paint, rust, scale and other contaminants
- Knot twisted with safety control bridle, removable bridle keep the knot oriented and extends brush life



CRIMPED WIRE CUP END BRUSHES

- Removes rust, paint and scale in hard-to-reach areas
- Crimped wire for light to medium-duty applications



Brush Dia.™	Fill Dia.™	Shank Size™	Max RPM	Model No.	Price /Each
STEEL					
1 3/4	0.012	1/4	25000	NU465	9.96
2 3/4	0.014	1/4	25000	NU466	14.60



Brush Dia.™	Arbor Hole™	Wire Gauge™	Trim Length™	Max RPM	Model No.	Price /Each
STEEL						
3	5/8-11NC	0.020	5/8	12000	NT969	15.30
STAINLESS						
3	5/8-11NC	0.020	5/8	12000	NT970	29.80

KNOT WIRE CUP BRUSHES

Osborn® knot wire cup brushes are rugged, efficient tools for fast, heavy-duty cleaning of large metal surfaces. They are specially designed for use on portable tools and are filled with special analysis Osborn® steel wire. Knot type brushes are recommended for extremely rigorous jobs.

- Removal of weld scale, rust, old paint and corrosion
- Cleaning and surface prep of metals



OSBORN
JACKSONLEA

STEEL

Brush Dia."	Arbor Hole"	Wire Gauge"	Row Wide	Trim Length"	Max RPM	Model No.	Price /Each
4	5/8-11NC	0.02	2	1	6000	BX635	47.90
6	5/8-11NC	0.035	2	1 3/4	6000	BX622	124.00

HIGH SPEED SMALL GRINDER

- Use on portable power tools operating at high speeds, or where uniform cleaning is desired
- Designed for high productivity and long life
- Knot style offers aggressive action
- Available in crimped, knotted and heavy-duty knotted styles
- Designed for 4 1/2" and 5" grinders



OSBORN
JACKSONLEA

Brush Dia."	Arbor Hole"	Colour	Wire Gauge"	Trim Length"	Max RPM	Model No.	Price /Each
STEEL							
2 3/4	1/2-13NC	Black	0.014	7/8	14 000	BX652	26.30
2 3/4	5/8-11NC	Steel	0.014	7/8	14 000	BX653	19.90
2 3/4	M-10 x 1.25	Gold	0.014	7/8	14 000	BX650	26.40
2 3/4	M-10 x 1.5	Silver	0.014	7/8	14 000	BX651	26.40
STAINLESS							
2 3/4	1/2-13NC	Black	0.014	7/8	14 000	BX658	41.70
2 3/4	5/8-11NC	Steel	0.014	7/8	14 000	BX659	31.70
2 3/4	M-10 x 1.25	Gold	0.014	7/8	14 000	BX656	41.60
2 3/4	M-10 x 1.5	Silver	0.014	7/8	14 000	BX657	41.60

TUBE/CRANKSHAFT BRUSHES

- For cleaning out small tubes, drill holes or any other small spaces

FELTON BRUSHES

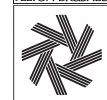

Brush Dia."	Brush Length"	O.A. Length"	Fill Dia."	Model No.	Price /Each
STEEL					
1/4	1 1/2	7	0.003	NU511	5.58
3/8	2	8	0.005	NU512	5.25
1/2	2	8	0.005	NU513	5.07
3/4	2 1/2	9	0.005	NU514	6.13
1	3	10	0.008	NU515	5.51
STAINLESS					
1/4	1 1/2	7	0.003	NU516	4.45
3/8	2	8	0.005	NU517	4.45
1/2	2	8	0.005	NU518	6.54
3/4	2 1/2	9	0.005	NU519	5.40
1	3	10	0.008	NU520	6.32
BRASS					
1/4	1 1/2	7	0.003	NU521	5.75
3/8	2	8	0.005	NU522	2.65
1/2	2	8	0.005	NU523	7.32
3/4	2 1/2	9	0.005	NU524	3.22
1	3	10	0.008	NU525	7.65
NYLON					
1/4	4 1/2	12	0.010	NU526	4.38
3/8	4 1/2	12	0.014	NU527	2.65
1/2	4 1/2	12	0.014	NU528	5.58
3/4	4 1/2	12	0.012	NU529	6.02
1	4 1/2	12	0.014	NU530	6.10
HAIR					
1/4	3 1/4	12	0.003	NU531	6.10
3/8	3 1/4	12	0.003	NU532	5.55
1/2	3 1/4	12	0.003	NU533	6.10
3/4	3 1/4	12	0.003	NU534	6.43
1	3 1/4	12	0.003	NU535	6.61

KNOTTED WIRE WHEEL CUP BRUSHES

- Strong and effective for heavy duty cleaning
- Top-quality USA steel
- Removes weld scale, rust, old paint and corrosion
- Designed for the most rugged jobs

FELTON BRUSHES

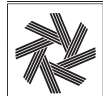

Brush Dia."	Fill Length"	Fill Dia."	Arbor Size"	Flared Dia.	RPM	Model No.	Price /Each
STEEL							
2 3/4	1	0.014	5/8-11	3	14 000	TC030	17.40
2 3/4	1	0.020	5/8-11	3	14 000	NU445	16.80
3 1/2	1	0.020	5/8-11	3 3/4	12 500	TT306	22.80
4	1 1/4	0.014	5/8-11	4 1/4	9 000	TT286	25.90
4	1 1/4	0.020	5/8-11	4 1/4	9 000	TT287	24.90
4	1 1/4	0.035	5/8-11	4 1/4	9 000	TT288	31.60
5	1 3/8	0.020	5/8-11	5 1/4	7 000	NU446	53.30
STAINLESS							
2 3/4	1	0.014	5/8-11	3	14 000	NU444	27.40
2 3/4	1	0.020	5/8-11	3	14 000	TT279	27.90
4	1 1/4	0.020	5/8-11	4 1/4	9 000	TT290	36.10

FLUE BRUSHES

- Mainly used for pipe, boiler tube and flue cleaning
- Filled with round carbon steel wires
- Comes with a 1/4" NPT fitting

FELTON BRUSHES

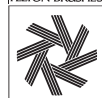

Brush Dia."	Brush Length"	O.A. Length"	Flue Dia."	Fill Dia."	Model No.	Price /Each
1/2	4	7 1/2	3/4	0.012	NU496	13.20
5/8	4	7 1/2	7/8	0.012	NU497	16.30
3/4	4	7 1/2	1	0.012	NU498	12.30
7/8	4	7 1/2	1 1/8	0.012	NU499	12.60
1	4	7 1/2	1 1/4	0.012	NU500	12.20
1 1/4	4	7 1/2	1 1/2	0.012	NU501	12.40
1 1/2	4	7 1/2	1 3/4	0.012	NU502	11.10
1 3/4	4	7 1/2	2 1/4	0.012	NU503	13.40
2	4	7 1/2	2 1/4	0.012	NU393	13.10
2 1/4	4	7 1/2	2 1/2	0.012	NU504	13.00
2 1/2	4	7 1/2	2 3/4	0.012	NU505	12.10
2 3/4	4	7 1/2	3	0.012	NU506	13.90
3	4	7 1/2	3 1/4	0.012	NU507	15.20
3 1/4	4	7 1/2	3 1/2	0.012	NU508	15.00
3 1/2	4	7 1/2	3 3/4	0.012	NU509	13.40
3 3/4	4	7 1/2	4	0.012	NU510	20.60

ABRASIVES

STEEL WOOL

UTILITY PADS

- 16 large pads of steel wool per package



Model No.	Grit	Price /Each
VS118	0000 (finest)	12.50
VS119	000 (extra fine)	10.90
VS120	00 (very fine)	8.61
VS121	0 (fine)	7.03
VS122	1 (medium)	7.03
VS123	2 (coarse)	7.03
VS124	3 (very coarse)	7.03

UTILITY ROLLS

- 6 large rolls per package

Model No.	Grit	Price /Each
VS133	0 (fine)	1.89
VS134	1 (medium)	1.89
VS135	2 (coarse)	1.89



ONE POUND TUBES

- One pound of continuous ribbon per package

Model No.	Grit	Price /Each
VS127	00 (very fine)	8.61
VS128	0 (fine)	7.03
VS129	1 (medium)	7.03



ABRASIVE CORDS & TAPE

- Debur, grind and polish hard-to-reach areas which are inaccessible to most standard tools
- Ideal for narrow slots, grooves, small holes, and curved surfaces
- Impregnated on both sides with aluminum oxide, silicon carbide or crocus, suitable for use on metal, plastic, and wood
- Cords and tapes are supplied on an adhesive tape-like spool in 50 foot lengths



Dia."	Grain	Alum. oxide Model No.	Price /Each	Crocus Model No.	Price /Each	S. Carbide Model No.	Price /Each
0.150	120	-	-	-	-	VS101	158.00
0.125	120	-	-	-	-	VS102	152.00
0.093	150	VS078	74.30	-	-	-	-
0.082	120	VS079	45.40	VS090	51.50	VS103	60.60
0.070	180	VS080	41.40	VS091	48.70	VS104	59.60
0.055	120	VS081	34.00	-	-	VS105	48.80
0.055	150	VS082	34.00	VS092	39.30	VS106	48.80
0.040	180	VS083	34.00	VS093	39.30	VS107	48.80
0.030	200	VS084	34.00	VS094	39.30	VS108	52.70
0.025	200	-	-	VS095	43.70	VS109	35.20
0.018	200	-	-	VS096	43.70	VS110	35.20
0.015	200	-	-	VS097	43.70	VS111	36.80
0.012	280	-	-	VS098	70.90	VS112	70.30
1/16	180	VS085*	39.40	-	-	VS113	52.90
3/32	180	VS086*	34.90	VS099*	39.90	VS114*	49.10
1/8	180	VS087*	36.50	-	-	VS115*	49.90
6/32	150	VS088*	39.90	-	-	VS116*	53.20
1/4	150	VS089*	44.20	VS100*	53.80	VS117*	58.10

*Tapes

PRO COUNTER DUSTERS

- Sturdy, light-weight brushing tools
- Recommended for dusting and chip removal
- Can be used wet or dry, will not load



Model No.	Length of brush"	Description	Trim Length"	Price /Each
BZ986	8	Black Tampico	2 1/2	8.41
NP243	8	Light Blue Polypro	2 1/2	8.02

V-GROOVE LONG HANDLE SCRATCH BRUSHES

- Designed for use in hard-to-reach areas that require a narrow face



Model No.	Description	Wire Rows	Trim Length"	Price /Each
BZ985	Stainless Steel	3 x 14	1 1/2	11.00
NP245	Steel	3 x 14	1 1/2	7.01

STRAIGHT HANDLE SCRATCH BRUSHES W/SCRAPER



Model No.	Length of brush"	O.A. Length"	Wire Rows	Trim Length"	Price /Each
BZ979	5 1/2	11 3/8	4 x 11	1 5/8	10.80

SMALL CLEANING SCRATCH BRUSHES

- Fill Diameter: 0.006"
- Brush Width: 3/4"



Model No.	Brush Length"	O.A. Length"	Fill Material	Wire Rows	Trim Length"	Price /Each
WOOD						
TC070	1 1/2	7 3/4	Stainless Steel	3 x 7	1/2	2.80
TC073	1 1/2	7 3/4	Brass	3 x 7	1/2	2.98
NU537	1 1/2	7 3/4	Nylon	3 x 7	1/2	2.82
PLASTIC						
NU538	1 1/2	7 3/4	Stainless Steel	3 x 7	1/2	2.82
NU539	1 1/2	7 3/4	Brass	3 x 7	1/2	2.91
NT947	1 1/2	7 3/4	Nylon	3 x 7	1/2	3.20
ANGLED BACK						
NP247	17/16	7 3/4	Brass	3 x 7	7/16	5.43
NP250	17/16	7 3/4	Polypro	3 x 7	7/16	4.66
BZ976	17/16	7 3/4	Stainless Steel	3 x 7	7/16	4.78
NP249	17/16	7 3/4	Steel	3 x 7	7/16	5.07
CURVED BACK						
NP255	2 1/2	8 5/8	Brass	2 x 9	5/8	3.61
NP256	2 1/2	8 5/8	Stainless	2 x 9	5/8	3.62

V-TRIM SMALL HANDLE SCRATCH BRUSHES



Model No.	Description	Length of brush"	O.A. Length"	Wire Rows	Trim Length"	Price /Each
NP246	Steel	1 1/2	7 7/8	3 x 7	1/2	6.83
NP244	Stainless Steel	1 1/2	7 7/8	3 x 7	1/2	7.62
BZ982	Brass	1 1/2	7 7/8	3 x 7	1/2	7.00

CURVED HANDLE SCRATCH BRUSHES



BZ606

Model No.	Length of brush"	O.A. Length"	Description	Wire Rows	Trim Length"	Price /Each
BZ970	6	13 11/16	Stainless Steel	3 x 19	1 1/8	10.90
BZ606	6	13 11/16	Steel	3 x 19	1 1/8	5.04
NP248*	6	13 11/16	Steel	3 x 19	1 1/8	6.55
BZ607**	6	13 11/16	Steel	4 x 19	1 1/8	6.10

*With scraper ** Heavy-duty

CURVED-HANDLE SCRATCH BRUSHES

- Durable hardwood handles that have a smooth finish for extra comfort



TC065



Model No.	Brush Width"	Brush Length"	O.A. Length"	Fill Material	Wire Rows	Trim Length"	Price /Each
TC065	15/16	6	14	Steel	3 x 19	1 1/8	2.84
TC068	15/16	6	14	Stainless Steel	3 x 19	1 1/8	6.85
TT167	15/16	6	14	Brass	3 x 19	1 1/8	6.41
TC066	1 1/8	6	14	Steel	4 x 19	1 1/8	4.21
TT170	1 1/8	6	14	Stainless Steel	4 x 19	1 1/8	7.80
TT169	1 1/8	6	14	Brass	4 x 19	1 1/8	8.07

SHOE HANDLE SCRATCH BRUSHES

- Durable hardwood handles that have a smooth finish for extra comfort
- Brush Width: 1 1/16"



TC067



Model No.	Brush Length"	O.A. Length"	Fill Material	Wire Rows	Trim Length"	Price /Each
TC067	5 1/4	10	Steel	5 x 13	1 1/8	3.33
TC074	5 1/4	10	Stainless Steel	5 x 13	1 1/8	7.93
TT168	5 1/4	10	Brass	5 x 13	1 1/8	7.29

SCRATCH BRUSHES WITH SCRAPER

- Durable hardwood handles that have a smooth finish for extra comfort
- Hang-up hole for easy storage



NU540



Model No.	Brush Width"	Brush Length"	O.A. Length"	Fill Material	Wire Rows	Trim Length"	Price /Each
STRAIGHT HANDLE							
TT171	1 1/2	5 1/2	11 3/8	Steel	5 x 13	1 1/8	7.71
CURVED HANDLE							
NU540	15/16	5 3/4	13	Steel	3 x 19	1	2.65
NU541	2	4	20	Steel	3 x 10	1	16.10
NU542	2	4	20	Stainless Steel	3 x 10	1	20.10

FLAT WIRE BUTCHER BLOCK BRUSHES

- Flat wire butcher block that offers a more aggressive scrub than round wire counterparts
- Durable hardwood block



NU548



Model No.	Brush Width"	Brush Length"	O.A. Length"	Fill Material	Wire Rows	Trim Length"	Price /Each
NU545	4	8 1/2	9	Flat Steel Wire	8 x 12	1 1/8	14.00
NU547**	4	8 1/2	9	Flat Steel Wire	8 x 12	1 1/8	18.50
NU546**	4	8 1/2	9	Flat Steel Wire	8 x 12	1 1/8	16.90
NU548	2 5/8	7	7 5/8	Flat Steel Wire	5 x 10	1	17.10
NU549	2 5/8	7	7 5/8	Flat Steel Wire	5 x 10	1 1/4	9.21
NU550	2 5/8	7	7 5/8	Flat Steel Wire	5 x 10	1 1/2	18.10

* Comes with a plastic handle

** Comes with a wood handle

ROUND WIRE BUTCHER BLOCK BRUSHES

- Round wire butcher block that offers a gentler scrub than flat wire counterparts
- Durable hardwood block
- Brush Width: 2 1/2"



NW102



Model No.	Brush Length"	O.A. Length"	Fill Material	Wire Rows	Trim Length"	Price /Each
NW102	7	7 1/4	Steel	6 x 19	1 1/8	6.35
NU543	7	7 1/4	Stainless Steel	6 x 19	1 1/8	7.74
NU544	7	7 1/4	Brass	6 x 19	1 1/8	6.35

INDUSTRIAL-DUTY SCRATCH BRUSHES

- Wood handle
- Choice of carbon or stainless steel bristles



NT607

NT609

NT615



Model No.	Length of Brush"	O.A. Length"	Wire Bristles	Rows	Trim Length"	Price /Each
LONG HANDLE BRUSHES						
NT607	5 3/4	13 3/4	Carbon Steel	3 x 19	1	2.50
NT608	5 3/4	13 3/4	Carbon Steel	4 x 19	1	3.15
NT611	5 3/4	13 3/4	Stainless Steel	3 x 19	1	3.85
NT612	6	10 1/4	Stainless Steel	4 x 19	1	4.75
SHOE HANDLE BRUSHES						
NT609	5 1/4	10 1/2	Carbon Steel	3 x 16	1	2.60
NT610	5 1/4	10 1/2	Carbon Steel	4 x 16	1	2.70
NT613	5	10 1/2	Stainless Steel	3 x 16	1	4.85
NT614	5	10 1/4	Stainless Steel	4 x 16	1	5.15
"TOOTHBRUSH" CLEANING BRUSH						
NT615	1 1/2"	7 3/4	Stainless Steel	3 x 7	1/2	1.20

CUTTING TOOLS

JOBBER DRILLS 118°

A012 SERIES

- Low thrust design with self centering split point makes for easier penetration
- TiN coated tip increases surface hardness and improves tool life
- Material: High Speed Steel
- Point Angle: 118°
- Manufacturing Standards: ANSI
- Finish: TiN Tip and Bright Body
- Cutting Direction: Right Hand

A012 SERIES - FRACTIONAL SIZE

Fractional Size	Decimal Size	L2	L1	Model No.	Price /Each
1/64"	0.0156"	3/16"	3/4"	TC0714*	3.29
1/32"	0.0313"	1/2"	1-3/8"	TC0726*	2.29
3/64"	0.0469"	3/4"	1-3/4"	TC0739*	2.29
1/16"	0.0625"	7/8"	1-7/8"	TC0743*	2.00
5/64"	0.0781"	1"	2"	TC0749*	2.00
3/32"	0.0938"	1-1/4"	2-1/4"	TC0756	2.11
7/64"	0.1094"	1-1/2"	2-5/8"	TC0763	2.26
1/8"	0.125"	1-5/8"	2-3/4"	TC0769	2.26
9/64"	0.1406"	1-3/4"	2-7/8"	TC0773	2.46
5/32"	0.1563"	2"	3-1/8"	TC0779	2.49
11/64"	0.1719"	2-1/8"	3-1/4"	TC0785	2.62
3/16"	0.1875"	2-5/16"	3-1/2"	TC0791	3.00
13/64"	0.2031"	2-7/16"	3-5/8"	TC0798	3.35
7/32"	0.2188"	2-1/2"	3-3/4"	TC0803	3.71
15/64"	0.2344"	2-5/8"	3-7/8"	TC0807	4.00
1/4"	0.25"	2-3/4"	4"	TC0811	4.27
17/64"	0.2656"	2-7/8"	4-1/8"	TC0815	5.13
9/32"	0.2813"	2-15/16"	4-1/4"	TC0820	5.33
19/64"	0.2968"	3-1/16"	4-3/8"	TC0823	6.15
5/16"	0.3125"	3-3/16"	4-1/2"	TC0825	6.82
21/64"	0.3281"	3-5/16"	4-5/8"	TC0828	7.55
11/32"	0.3437"	3-7/16"	4-3/4"	TC0831	8.40
23/64"	0.3594"	3-1/2"	4-7/8"	TC0834	9.51

*No split point or TiN tip

A012 SERIES - WIRE GAUGE SIZE

Wire Gauge Size	Decimal Size	L2	L1	Model No.	Price /Each
#80	0.0135"	1/8"	3/4"	TC0712*	4.24
#79	0.0145"	1/8"	3/4"	TC0713*	4.24
#78	0.016"	3/16"	7/8"	TC0715*	4.24
#77	0.018"	3/16"	7/8"	TC0716*	3.06
#76	0.02"	3/16"	7/8"	TC0717*	3.06
#75	0.021"	1/4"	1"	TC0718*	3.06
#74	0.0225"	1/4"	1"	TC0719*	3.06
#73	0.024"	5/16"	1-1/8"	TC0720*	3.06
#72	0.025"	5/16"	1-1/8"	TC0721*	3.06
#71	0.026"	3/8"	1-1/4"	TC0722*	3.06
#70	0.028"	3/8"	1-1/4"	TC0723*	2.56
#69	0.0292"	1/2"	1-3/8"	TC0724*	2.56
#68	0.031"	1/2"	1-3/8"	TC0725*	2.33
#67	0.032"	1/2"	1-3/8"	TC0727*	2.33
#66	0.033"	1/2"	1-3/8"	TC0728*	2.33
#65	0.035"	5/8"	1-1/2"	TC0729*	2.33
#64	0.036"	5/8"	1-1/2"	TC0730*	2.33
#63	0.037"	5/8"	1-1/2"	TC0731*	2.33
#62	0.038"	5/8"	1-1/2"	TC0732*	2.33
#61	0.039"	11/16"	1-5/8"	TC0733*	2.33
#60	0.04"	11/16"	1-5/8"	TC0734*	2.29
#59	0.041"	11/16"	1-5/8"	TC0735*	2.29
#58	0.042"	11/16"	1-5/8"	TC0736*	2.29
#57	0.043"	3/4"	1-3/4"	TC0737*	2.29
#56	0.0465"	3/4"	1-3/4"	TC0738*	2.29
#55	0.052"	7/8"	1-7/8"	TC0740*	2.29
#54	0.055"	7/8"	1-7/8"	TC0741*	2.29
#53	0.0595"	7/8"	1-7/8"	TC0742*	2.29
#52	0.0635"	7/8"	1-7/8"	TC0744*	2.06
#51	0.0669"	1"	2"	TC0745*	2.06
#50	0.07"	1"	2"	TC0746*	2.06
#49	0.073"	1"	2"	TC0747*	2.06
#48	0.076"	1"	2"	TC0748*	2.06
#47	0.0785"	1"	2"	TC0750*	2.06
#46	0.081"	1-1/8"	2-1/8"	TC0751	2.11
#45	0.082"	1-1/8"	2-1/8"	TC0752	2.11
#44	0.086"	1-1/8"	2-1/8"	TC0753	2.11
#43	0.089"	1-1/4"	2-1/4"	TC0754	2.11
#42	0.0935"	1-1/4"	2-1/4"	TC0755	2.11
#41	0.096"	1-3/8"	2-3/8"	TC0757	2.11

*No split point or TiN tip

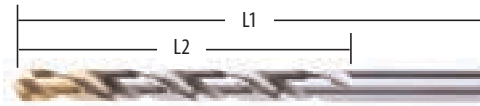

Fractional Size	Decimal Size	L2	L1	Model No.	Price /Each
3/8"	0.375"	3-5/8"	5"	TC0836	9.77
25/64"	0.3906"	3-3/4"	5-1/8"	TC0839	11.10
13/32"	0.4063"	3-7/8"	5-1/4"	TC0842	11.40
27/64"	0.4219"	3-15/16"	5-3/8"	TC0844	12.70
7/16"	0.4375"	4-1/16"	5-1/2"	TC0845	13.20
29/64"	0.4531"	4-3/16"	5-5/8"	TC0846	14.70
15/32"	0.4687"	4-5/16"	5-3/4"	TC0847	15.70
31/64"	0.4844"	4-3/8"	5-7/8"	TC0848	16.40
1/2"	0.5"	4-1/2"	6"	TC0849	16.60
33/64"	0.5156"	4-13/16"	6-5/8"	TC0850	30.70
17/32"	0.5313"	4-13/16"	6-5/8"	TC0851	32.20
35/64"	0.5469"	4-13/16"	6-5/8"	TC0852	34.80
9/16"	0.5625"	4-13/16"	6-5/8"	TC0853	36.50
37/64"	0.5781"	4-13/16"	6-5/8"	TC0854	36.70
19/32"	0.5937"	5-3/16"	7-1/8"	TC0855	37.50
39/64"	0.6094"	5-3/16"	7-1/8"	TC0856	41.10
5/8"	0.625"	5-3/16"	7-1/8"	TC0857	40.30
21/32"	0.6563"	5-3/16"	7-1/8"	TC0858	42.70
11/16"	0.6875"	5-5/8"	7-5/8"	TC0859	48.70
45/64"	0.7031"	5-5/8"	7-5/8"	TC0860	69.40
23/32"	0.7188"	5-5/8"	7-5/8"	TC0861	73.20
47/64"	0.7344"	6"	8"	TC0862	77.70
3/4"	0.75"	6"	8"	TC0863	82.10

JOBBER DRILLS (CONT'D)

A012 SERIES - LETTER SIZE

Letter Size	Decimal Size	L2	L1	Model No.	Price /Each
A	0.234"	2-5/8"	3-7/8"	TC0806	4.98
B	0.238"	2-3/4"	4"	TC0808	4.98
C	0.242"	2-3/4"	4"	TC0809	4.98
D	0.246"	2-3/4"	4"	TC0810	4.98
E	0.25"	2-3/4"	4"	TC0812	4.27
F	0.257"	2-7/8"	4-1/8"	TC0813	5.35
G	0.261"	2-7/8"	4-1/8"	TC0814	5.98
H	0.266"	2-7/8"	4-1/8"	TC0816	5.98
I	0.272"	2-7/8"	4-1/8"	TC0817	5.98
J	0.277"	2-7/8"	4-1/8"	TC0818	6.44
K	0.281"	2-15/16"	4-1/4"	TC0819	7.08
L	0.29"	2-15/16"	4-1/4"	TC0821	7.08
M	0.295"	3-1/16"	4-3/8"	TC0822	7.51

Letter Size	Decimal Size	L2	L1	Model No.	Price /Each
N	0.302"	3-1/16"	4-3/8"	TC0824	7.64
O	0.316"	3-3/16"	4-1/2"	TC0826	7.64
P	0.323"	3-5/16"	4-5/8"	TC0827	8.60
Q	0.332"	3-7/16"	4-3/4"	TC0829	8.60
R	0.339"	3-7/16"	4-3/4"	TC0830	9.17
S	0.348"	3-1/2"	4-7/8"	TC0832	9.75
T	0.358"	3-1/2"	4-7/8"	TC0833	11.10
U	0.368"	3-5/8"	5"	TC0835	11.10
V	0.377"	3-5/8"	5"	TC0837	11.40
W	0.386"	4-1/8"	5-1/8"	TC0838	11.80
X	0.397"	3-3/4"	5-1/8"	TC0840	14.20
Y	0.404"	3-7/8"	5-1/4"	TC0841	16.10
Z	0.413"	3-7/8"	5-1/4"	TC0843	17.10

JOBBER DRILLS 118°

- Material: High Speed Steel
- Point Angle: 118°
- Manufacturing Standards: ANSI
- Cutting Direction: Right Hand



R10 SERIES - FRACTIONAL SIZE

- Steam oxide finish reduces wear and chip welding in harder ferrous materials for increased wear resistance and lubricity

Fractional Size	Decimal Size	L2	L1	Model No.	Price /Each
1/64"	0.0156"	3/16"	3/4"	TC0864	2.66
1/32"	0.0313"	1/2"	1-3/8"	TC0865	1.62
3/64"	0.0469"	3/4"	1-3/4"	TC0866	1.62
1/16"	0.0625"	7/8"	1-7/8"	TC0867	1.49
5/64"	0.0781"	1"	2"	TC0868	1.51
3/32"	0.0938"	1-1/4"	2-1/4"	TC0869	1.51
7/64"	0.1094"	1-1/2"	2-5/8"	TC0870	1.58
1/8"	0.125"	1-5/8"	2-3/4"	TC0871	1.53
9/64"	0.1406"	1-3/4"	2-7/8"	TC0872	1.69
5/32"	0.1563"	2"	3-1/8"	TC0873	1.73
11/64"	0.1719"	2-1/8"	3-1/4"	TC0874	1.87
3/16"	0.1875"	2-5/16"	3-1/2"	TC0875	2.09
13/64"	0.2031"	2-7/16"	3-5/8"	TC0876	2.31
7/32"	0.2188"	2-1/2"	3-3/4"	TC0877	2.56
15/64"	0.2344"	2-5/8"	3-7/8"	TC0878	2.78
1/4"	0.25"	2-3/4"	4"	TC0879	2.91
17/64"	0.2656"	2-7/8"	4-1/8"	TC0880	3.55
9/32"	0.2813"	2-15/16"	4-1/4"	TC0881	3.66
19/64"	0.2969"	3-1/16"	4-3/8"	TC0882	4.24
5/16"	0.3125"	3-3/16"	4-1/2"	TC0883	4.69
21/64"	0.3281"	3-5/16"	4-5/8"	TC0884	5.18
11/32"	0.3437"	3-7/16"	4-3/4"	TC0885	5.80

Fractional Size	Decimal Size	L1	L2	Model No.	Price /Each
23/64"	0.3594"	3-1/2"	4-7/8"	TC0886	6.53
3/8"	0.375"	3-5/8"	5"	TC0887	6.60
25/64"	0.3906"	3-3/4"	5-1/8"	TC0888	7.62
13/32"	0.4063"	3-7/8"	5-1/4"	TC0889	7.80
27/64"	0.4219"	3-15/16"	5-3/8"	TC0890	8.71
7/16"	0.4375"	4-1/16"	5-1/2"	TC0891	9.06
29/64"	0.4531"	4-3/16"	5-5/8"	TC0892	10.10
15/32"	0.4687"	4-5/16"	5-3/4"	TC0893	10.80
31/64"	0.4844"	4-3/8"	5-7/8"	TC0894	11.30
1/2"	0.5"	4-1/2"	6"	TC0895	11.30
33/64"	0.5156"	4-13/16"	6-5/8"	TC0896	20.40
17/32"	0.5313"	4-13/16"	6-5/8"	TC0897	21.10
35/64"	0.5469"	4-13/16"	6-5/8"	TC0898	23.20
9/16"	0.5625"	4-13/16"	6-5/8"	TC0899	23.80
37/64"	0.5781"	4-13/16"	6-5/8"	TC0900	25.00
19/32"	0.5937"	5-3/16"	7-1/8"	TC0901	25.00
39/64"	0.6094"	5-3/16"	7-1/8"	TC0902	26.80
5/8"	0.625"	5-3/16"	7-1/8"	TC0903	26.30
41/64"	0.6406"	5-3/16"	7-1/8"	TC0904	29.60
21/32"	0.6563"	5-3/16"	7-1/8"	TC0905	31.10
43/64"	0.6719"	5-5/8"	7-5/8"	TC0906	33.60
11/16"	0.6875"	5-5/8"	7-5/8"	TC0907	33.60

R10P SERIES - FRACTIONAL SIZE

- Bright finish improves chip flow in soft or non-ferrous materials

Fractional Size	Decimal Size	L2	L1	Model No.	Price /Each
1/64"	0.0156"	3/16"	3/4"	TC0908	3.71
1/32"	0.0313"	1/2"	1-3/8"	TC0909	2.26
3/64"	0.0469"	3/4"	1-3/4"	TC0910	2.26
1/16"	0.0625"	7/8"	1-7/8"	TC0911	2.07
5/64"	0.0781"	1"	2"	TC0912	2.11
3/32"	0.0938"	1-1/4"	2-1/4"	TC0913	2.11
7/64"	0.1094"	1-1/2"	2-5/8"	TC0914	2.20
1/8"	0.125"	1-5/8"	2-3/4"	TC0915	2.13
9/64"	0.1406"	1-3/4"	2-7/8"	TC0916	2.38
5/32"	0.1563"	2"	3-1/8"	TC0917	2.42
11/64"	0.1719"	2-1/8"	3-1/4"	TC0918	2.64
3/16"	0.1875"	2-5/16"	3-1/2"	TC0919	2.91
13/64"	0.2031"	2-7/16"	3-5/8"	TC0920	3.22
7/32"	0.2188"	2-1/2"	3-3/4"	TC0921	3.58
15/64"	0.2344"	2-5/8"	3-7/8"	TC0922	3.89
1/4"	0.25"	2-3/4"	4"	TC0923	4.06
17/64"	0.2656"	2-7/8"	4-1/8"	TC0924	4.95
9/32"	0.2813"	2-15/16"	4-1/4"	TC0925	5.11
19/64"	0.2969"	3-1/16"	4-3/8"	TC0926	5.93
5/16"	0.3125"	3-3/16"	4-1/2"	TC0927	6.57
21/64"	0.3281"	3-5/16"	4-5/8"	TC0928	7.26
11/32"	0.3437"	3-7/16"	4-3/4"	TC0929	8.11

Fraction Size	Decimal Size	L2	L1	Model No.	Price /Each
23/64"	0.3594"	3-1/2"	4-7/8"	TC0930	9.13
3/8"	0.375"	3-5/8"	5"	TC0931	9.24
25/64"	0.3906"	3-3/4"	5-1/8"	TC0932	10.70
13/32"	0.4063"	3-7/8"	5-1/4"	TC0933	10.90
27/64"	0.4219"	3-15/16"	5-3/8"	TC0934	12.20
7/16"	0.4375"	4-1/16"	5-1/2"	TC0935	12.70
29/64"	0.4531"	4-3/16"	5-5/8"	TC0936	14.10
15/32"	0.4687"	4-5/16"	5-3/4"	TC0937	15.10
31/64"	0.4844"	4-3/8"	5-7/8"	TC0938	15.80
1/2"	0.5"	4-1/2"	6"	TC0939	15.80
33/64"	0.5156"	4-13/16"	6-5/8"	TC0940	28.60
17/32"	0.5313"	4-13/16"	6-5/8"	TC0941	29.50
35/64"	0.5469"	4-13/16"	6-5/8"	TC0942	32.50
9/16"	0.5625"	4-13/16"	6-5/8"	TC0943	33.40
37/64"	0.5781"	4-13/16"	6-5/8"	TC0944	34.10
19/32"	0.5937"	5-3/16"	7-1/8"	TC0945	35.00
39/64"	0.6094"	5-3/16"	7-1/8"	TC0946	37.60
5/8"	0.625"	5-3/16"	7-1/8"	TC0947	36.90
41/64"	0.6406"	5-3/16"	7-1/8"	TC0948	41.50
21/32"	0.6563"	5-3/16"	7-1/8"	TC0949	43.50
43/64"	0.6719"	5-5/8"	7-5/8"	TC0950	47.00
11/16"	0.6875"	5-5/8"	7-5/8"	TC0951	47.00

CUTTING TOOLS

JOBBER DRILLS 118° (CONT.)

R18 SERIES - WIRE GAUGE SIZE

- Steam oxide finish reduces wear and chip welding in harder ferrous materials for increased wear resistance and lubricity

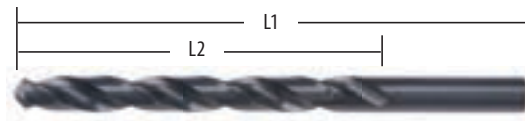

Wire Gauge Size	Decimal Size	L2	L1	Model No.	Price /Each
#80	0.0135"	1/8"	3/4"	TCP004	2.67
#79	0.0145"	1/8"	3/4"	TCP005	2.67
#78	0.016"	3/16"	7/8"	TCP006	2.22
#77	0.018"	3/16"	7/8"	TCP007	2.22
#76	0.02"	3/16"	7/8"	TCP008	2.22
#75	0.021"	1/4"	1"	TCP009	2.22
#74	0.0225"	1/4"	1"	TCP010	2.22
#73	0.024"	5/16"	1-1/8"	TCP011	2.22
#72	0.025"	5/16"	1-1/8"	TCP012	2.22
#71	0.026"	3/8"	1-1/4"	TCP013	2.22
#70	0.028"	3/8"	1-1/4"	TCP014	1.78
#69	0.0292"	1/2"	1-3/8"	TCP015	1.78
#68	0.031"	1/2"	1-3/8"	TCP016	1.64
#67	0.032"	1/2"	1-3/8"	TCP017	1.64
#66	0.033"	1/2"	1-3/8"	TCP018	1.64
#65	0.035"	5/8"	1-1/2"	TCP019	1.64
#64	0.036"	5/8"	1-1/2"	TCP020	1.64
#63	0.037"	5/8"	1-1/2"	TCP021	1.64
#62	0.038"	5/8"	1-1/2"	TCP022	1.64
#61	0.039"	11/16"	1-5/8"	TCP023	1.64
#60	0.04"	11/16"	1-5/8"	TCP024	1.58
#59	0.041"	11/16"	1-5/8"	TCP025	1.58
#58	0.042"	11/16"	1-5/8"	TCP026	1.58
#57	0.043"	3/4"	1-3/4"	TCP027	1.58
#56	0.0465"	3/4"	1-3/4"	TCP028	1.58
#55	0.052"	7/8"	1-7/8"	TCP029	1.58
#54	0.055"	7/8"	1-7/8"	TCP030	1.58
#53	0.0595"	7/8"	1-7/8"	TCP031	1.58
#52	0.0635"	7/8"	1-7/8"	TCP032	1.51
#51	0.067"	1"	2"	TCP033	1.51
#50	0.07"	1"	2"	TCP034	1.51
#49	0.073"	1"	2"	TCP035	1.51
#48	0.076"	1"	2"	TCP036	1.51
#47	0.0785"	1"	2"	TCP037	1.51
#46	0.081"	1-1/8"	2-1/8"	TCP038	1.51
#45	0.082"	1-1/8"	2-1/8"	TCP039	1.51
#44	0.086"	1-1/8"	2-1/8"	TCP040	1.51
#43	0.089"	1-1/4"	2-1/4"	TCP041	1.51
#42	0.0935"	1-1/4"	2-1/4"	TCP042	1.51
#41	0.096"	1-3/8"	2-3/8"	TCP043	1.49

Wire Gauge Size	Decimal Size	L2	L1	Model No.	Price /Each
#40	0.098"	1-3/8"	2-3/8"	TCP044	1.49
#39	0.0995"	1-3/8"	2-3/8"	TCP045	1.51
#38	0.1015"	1-7/16"	2-1/2"	TCP046	1.51
#37	0.104"	1-7/16"	2-1/2"	TCP047	1.51
#36	0.1065"	1-7/16"	2-1/2"	TCP048	1.49
#35	0.11"	1-1/2"	2-5/8"	TCP049	1.51
#34	0.111"	1-1/2"	2-5/8"	TCP050	1.51
#33	0.113"	1-1/2"	2-5/8"	TCP051	1.51
#32	0.116"	1-5/8"	2-3/4"	TCP052	1.51
#31	0.12"	1-5/8"	2-3/4"	TCP053	1.51
#30	0.1285"	1-5/8"	2-3/4"	TCP054	1.51
#29	0.136"	1-3/4"	2-7/8"	TCP055	1.51
#28	0.1405"	1-3/4"	2-7/8"	TCP056	1.55
#27	0.144"	1-7/8"	3"	TCP057	1.66
#26	0.147"	1-7/8"	3"	TCP058	1.66
#25	0.1495"	1-7/8"	3"	TCP059	1.66
#24	0.152"	2"	3-1/8"	TCP060	1.75
#23	0.154"	2"	3-1/8"	TCP061	1.75
#22	0.157"	2"	3-1/8"	TCP062	1.75
#21	0.159"	2-1/8"	3-1/4"	TCP063	1.73
#20	0.161"	2-1/8"	3-1/4"	TCP064	1.87
#19	0.166"	2-1/8"	3-1/4"	TCP065	1.87
#18	0.1695"	2-1/8"	3-1/4"	TCP066	1.89
#17	0.173"	2-3/16"	3-3/8"	TCP067	2.27
#16	0.177"	2-3/16"	3-3/8"	TCP068	2.27
#15	0.18"	2-3/16"	3-3/8"	TCP069	2.27
#14	0.182"	2-3/16"	3-3/8"	TCP070	2.27
#13	0.185"	2-5/16"	3-1/2"	TCP071	2.27
#12	0.189"	2-5/16"	3-1/2"	TCP072	2.33
#11	0.191"	2-5/16"	3-1/2"	TCP073	2.31
#10	0.1935"	2-7/16"	3-5/8"	TCP074	2.49
#9	0.196"	2-7/16"	3-5/8"	TCP075	2.51
#8	0.199"	2-7/16"	3-5/8"	TCP076	2.51
#7	0.201"	2-7/16"	3-5/8"	TCP077	2.46
#6	0.204"	2-1/2"	3-3/4"	TCP078	2.84
#5	0.2055"	2-1/2"	3-3/4"	TCP079	2.84
#4	0.209"	2-1/2"	3-3/4"	TCP080	2.84
#3	0.213"	2-1/2"	3-3/4"	TCP081	2.82
#2	0.221"	2-5/8"	3-7/8"	TCP082	3.13
#1	0.228"	2-5/8"	3-7/8"	TCP083	3.11



R18P SERIES - WIRE GAUGE SIZE

- Bright finish improves chip flow in soft or non-ferrous materials

Wire Gauge Size	Decimal Size	L2	L1	Model No.	Price /Each
#97	0.0059"	1/16"	3/4"	TCP084	19.40
#96	0.0063"	1/16"	3/4"	TCP085	19.40
#95	0.0067"	1/16"	3/4"	TCP086	17.60
#94	0.0071"	1/16"	3/4"	TCP087	17.60
#93	0.0075"	1/16"	3/4"	TCP088	12.20
#92	0.0079"	1/16"	3/4"	TCP089	12.20
#91	0.0083"	5/64"	3/4"	TCP090	12.20
#90	0.0087"	5/64"	3/4"	TCP091	12.20
#89	0.0091"	5/64"	3/4"	TCP092	12.20
#88	0.0095"	5/64"	3/4"	TCP093	12.20
#87	0.01"	5/64"	3/4"	TCP094	9.68
#86	0.0105"	3/32"	3/4"	TCP095	9.68
#85	0.011"	3/32"	3/4"	TCP096	8.73
#84	0.0115"	3/32"	3/4"	TCP097	8.73
#83	0.012"	3/32"	3/4"	TCP098	8.73
#82	0.0125"	3/32"	3/4"	TCP099	7.58
#81	0.013"	3/32"	3/4"	TCP100	7.58
#80	0.0135"	1/8"	3/4"	TCP101	3.75
#79	0.0145"	1/8"	3/4"	TCP102	3.75
#78	0.016"	3/16"	7/8"	TCP103	3.11
#77	0.018"	3/16"	7/8"	TCP104	3.11
#76	0.02"	3/16"	7/8"	TCP105	3.11
#75	0.021"	1/4"	1"	TCP106	3.11
#74	0.0225"	1/4"	1"	TCP107	3.11
#73	0.024"	5/16"	1-1/8"	TCP108	3.11
#72	0.025"	5/16"	1-1/8"	TCP109	3.11
#71	0.026"	3/8"	1-1/4"	TCP110	3.11
#70	0.028"	3/8"	1-1/4"	TCP111	2.51

Wire Gauge Size	Decimal Size	L2	L1	Model No.	Price /Each
#69	0.0292"	1/2"	1-3/8"	TCP112	2.51
#68	0.031"	1/2"	1-3/8"	TCP113	2.29
#67	0.032"	1/2"	1-3/8"	TCP114	2.29
#66	0.033"	1/2"	1-3/8"	TCP115	2.29
#65	0.035"	5/8"	1-1/2"	TCP116	2.29
#64	0.036"	5/8"	1-1/2"	TCP117	2.29
#63	0.037"	5/8"	1-1/2"	TCP118	2.29
#62	0.038"	5/8"	1-1/2"	TCP119	2.29
#61	0.039"	11/16"	1-5/8"	TCP120	2.29
#60	0.04"	11/16"	1-5/8"	TCP121	2.15
#59	0.041"	11/16"	1-5/8"	TCP122	2.15
#58	0.042"	11/16"	1-5/8"	TCP123	2.15
#57	0.043"	3/4"	1-3/4"	TCP124	2.11
#56	0.0465"	3/4"	1-3/4"	TCP125	2.11
#55	0.052"	7/8"	1-7/8"	TCP126	2.11
#54	0.055"	7/8"	1-7/8"	TCP127	2.11
#53	0.0595"	7/8"	1-7/8"	TCP128	2.11
#52	0.0635"	7/8"	1-7/8"	TCP129	2.11
#51	0.067"	1"	2"	TCP130	2.11
#50	0.07"	1"	2"	TCP131	2.11
#49	0.073"	1"	2"	TCP132	2.11
#48	0.076"	1"	2"	TCP133	2.11
#47	0.0785"	1"	2"	TCP134	2.11
#46	0.081"	1-1/8"	2-1/8"	TCP135	2.11
#45	0.082"	1-1/8"	2-1/8"	TCP136	2.11
#44	0.086"	1-1/8"	2-1/8"	TCP137	2.07
#43	0.089"	1-1/4"	2-1/4"	TCP138	2.07
#42	0.0935"	1-1/4"	2-1/4"	TCP139	2.11

R18P SERIES - WIRE GAUGE SIZE (CONT.)

Wire Gauge Size	Decimal Size	L2	L1	Model No.	Price /Each
#41	0.096"	1-3/8"	2-3/8"	TCP140	2.11
#40	0.098"	1-3/8"	2-3/8"	TCP141	2.07
#39	0.0995"	1-3/8"	2-3/8"	TCP142	2.11
#38	0.1015"	1-7/16"	2-1/2"	TCP143	2.11
#37	0.104"	1-7/16"	2-1/2"	TCP144	2.11
#36	0.1065"	1-7/16"	2-1/2"	TCP145	2.07
#35	0.11"	1-1/2"	2-5/8"	TCP146	2.11
#34	0.111"	1-1/2"	2-5/8"	TCP147	2.11
#33	0.113"	1-1/2"	2-5/8"	TCP148	2.11
#32	0.116"	1-5/8"	2-3/4"	TCP149	2.11
#31	0.12"	1-5/8"	2-3/4"	TCP150	2.11
#30	0.1285"	1-5/8"	2-3/4"	TCP151	2.11
#29	0.136"	1-3/4"	2-7/8"	TCP152	2.11
#28	0.1405"	1-3/4"	2-7/8"	TCP153	2.15
#27	0.144"	1-7/8"	3"	TCP154	2.31
#26	0.147"	1-7/8"	3"	TCP155	2.33
#25	0.1495"	1-7/8"	3"	TCP156	2.31
#24	0.152"	2"	3-1/8"	TCP157	2.44
#23	0.154"	2"	3-1/8"	TCP158	2.44
#22	0.157"	2"	3-1/8"	TCP159	2.44
#21	0.159"	2-1/8"	3-1/4"	TCP160	2.42

R15 SERIES - LETTER SIZE

- Steam oxide finish reduces wear and chip welding in harder ferrous materials for increased wear resistance and lubricity

Letter Size	Decimal Size	L2	L1	Model No.	Price /Each
A	0.234"	2-5/8"	3-7/8"	TCO952	3.53
B	0.2374"	2-3/4"	4"	TCO953	3.53
C	0.2421"	2-3/4"	4"	TCO954	3.53
D	0.2461"	2-3/4"	4"	TCO955	3.53
E	0.25"	2-3/4"	4"	TCO956	3.27
F	0.2571"	2-7/8"	4-1/8"	TCO957	3.77
G	0.261"	2-7/8"	4-1/8"	TCO958	4.22
H	0.2661"	2-7/8"	4-1/8"	TCO959	4.22
I	0.272"	2-7/8"	4-1/8"	TCO960	4.22
J	0.2772"	2-7/8"	4-1/8"	TCO961	4.53
K	0.2811"	2-15/16"	4-1/4"	TCO962	4.98
L	0.2902"	2-15/16"	4-1/4"	TCO963	4.98
M	0.2949"	3-1/16"	4-3/8"	TCO964	5.27
N	0.302"	3-1/16"	4-3/8"	TCO965	5.27
O	0.3161"	3-3/16"	4-1/2"	TCO966	5.35
P	0.3228"	3-5/16"	4-5/8"	TCO967	6.06
Q	0.3319"	3-7/16"	4-3/4"	TCO968	6.06
R	0.339"	3-7/16"	4-3/4"	TCO969	6.44
S	0.348"	3-1/2"	4-7/8"	TCO970	6.84
T	0.358"	3-1/2"	4-7/8"	TCO971	7.78
U	0.368"	3-5/8"	5"	TCO972	7.78
V	0.3772"	3-5/8"	5"	TCO973	7.98
W	0.3858"	3-3/4"	5-1/8"	TCO974	8.26
X	0.3969"	3-3/4"	5-1/8"	TCO975	10.00
Y	0.4039"	3-7/8"	5-1/4"	TCO976	11.20
Z	0.413"	3-7/8"	5-1/4"	TCO977	12.00

JOBBER DRILLS 135°

- Low thrust design and self-centering split point makes for easier penetration
- Unique surface treatment for improved wear resistance in hard ferrous alloys
- Material: High Speed Steel • Point Angle: 135°
- Manufacturing Standards: ANSI
- Finish: Purple and Bronze • Cutting Direction: Right Hand

HX10 SERIES - FRACTIONAL SIZE

Fractional Size	Decimal Size	L2	L1	Model No.	Price /Each
1/16"	0.0625"	7/8"	1-7/8"	TCP182	2.18
5/64"	0.0781"	1"	2"	TCP183	2.18
3/32"	0.0938"	1-1/4"	2-1/4"	TCP184	2.18
7/64"	0.1094"	1-1/2"	2-5/8"	TCP185	2.31
1/8"	0.125"	1-5/8"	2-3/4"	TCP186	2.31
9/64"	0.1406"	1-3/4"	2-7/8"	TCP187	2.51
5/32"	0.1563"	2"	3-1/8"	TCP188	2.55
11/64"	0.1719"	2-1/8"	3.25"	TCP189	2.78
3/16"	0.1875"	2-5/16"	3-1/2"	TCP190	3.09
13/64"	0.2031"	2-7/16"	3-5/8"	TCP191	3.38
7/32"	0.2188"	2-1/2"	3-3/4"	TCP192	3.77
15/64"	0.2344"	2-5/8"	3-7/8"	TCP193	4.09
1/4"	0.25"	2-3/4"	4"	TCP194	4.35
17/64"	0.2656"	2-7/8"	4-1/8"	TCP195	5.22
9/32"	0.2813"	2-15/16"	4-1/4"	TCP196	5.37

Wire Gauge Size	Decimal Size	L2	L1	Model No.	Price /Each
#20	0.161"	2-1/8"	3-1/4"	TCP161	2.62
#19	0.166"	2-1/8"	3-1/4"	TCP162	2.62
#18	0.1695"	2-1/8"	3-1/4"	TCP163	2.66
#17	0.173"	2-3/16"	3-3/8"	TCP164	3.18
#16	0.177"	2-3/16"	3-3/8"	TCP165	3.18
#15	0.18"	2-3/16"	3-3/8"	TCP166	3.18
#14	0.182"	2-3/16"	3-3/8"	TCP167	3.18
#13	0.185"	2-5/16"	3-1/2"	TCP168	3.18
#12	0.189"	2-5/16"	3-1/2"	TCP169	3.26
#11	0.191"	2-5/16"	3-1/2"	TCP170	3.22
#10	0.1935"	2-7/16"	3-5/8"	TCP171	3.46
#9	0.196"	2-7/16"	3-5/8"	TCP172	3.51
#8	0.199"	2-7/16"	3-5/8"	TCP173	3.51
#7	0.201"	2-7/16"	3-5/8"	TCP174	3.44
#6	0.204"	2-1/2"	3-3/4"	TCP175	3.98
#5	0.2055"	2-1/2"	3-3/4"	TCP176	3.98
#4	0.209"	2-1/2"	3-3/4"	TCP177	3.98
#3	0.213"	2-1/2"	3-3/4"	TCP178	3.93
#2	0.221"	2-5/8"	3-7/8"	TCP179	4.37
#1	0.228"	2-5/8"	3-7/8"	TCP180	4.35

R15P SERIES - LETTER SIZE

- Bright finish improves chip flow in soft or non-ferrous materials

Letter Size	Decimal Size	L2	L1	Model No.	Price /Each
A	0.234"	2-5/8"	3-7/8"	TCO978	4.93
B	0.2374"	2-3/4"	4"	TCO979	4.93
C	0.2421"	2-3/4"	4"	TCO980	4.93
D	0.2461"	2-3/4"	4"	TCO981	4.93
E	0.25"	2-3/4"	4"	TCO982	4.58
F	0.2571"	2-7/8"	4-1/8"	TCO983	5.26
G	0.261"	2-7/8"	4-1/8"	TCO984	5.91
H	0.2661"	2-7/8"	4-1/8"	TCO985	5.91
I	0.272"	2-7/8"	4-1/8"	TCO986	5.91
J	0.2772"	2-7/8"	4-1/8"	TCO987	6.33
K	0.2811"	2-15/16"	4-1/4"	TCO988	6.97
L	0.2902"	2-15/16"	4-1/4"	TCO989	6.97
M	0.2949"	3-1/16"	4-3/8"	TCO990	7.38
N	0.302"	3-1/16"	4-3/8"	TCO991	7.38
O	0.3161"	3-3/16"	4-1/2"	TCO992	7.48
P	0.3228"	3-5/16"	4-5/8"	TCO993	8.48
Q	0.3319"	3-7/16"	4-3/4"	TCO994	8.48
R	0.339"	3-7/16"	4-3/4"	TCO995	9.00
S	0.348"	3-1/2"	4-7/8"	TCO996	9.59
T	0.358"	3-1/2"	4-7/8"	TCO997	10.90
U	0.368"	3-5/8"	5"	TCO998	10.90
V	0.3772"	3-5/8"	5"	TCO999	11.20
W	0.3858"	3-3/4"	5-1/8"	TCP000	11.50
X	0.3969"	3-3/4"	5-1/8"	TCP001	14.00
Y	0.4039"	3-7/8"	5-1/4"	TCP002	15.70
Z	0.413"	3-7/8"	5-1/4"	TCP003	16.80

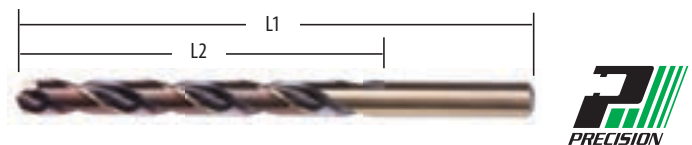

Fractional Size	Decimal Size	L2	L1	Model No.	Price /Each
19/64"	0.2969"	3-1/16"	4-3/8"	TCP197	6.22
5/16"	0.3125"	3-3/16"	4-1/2"	TCP198	6.88
21/64"	0.3281"	3-5/16"	4-5/8"	TCP199	7.64
11/32"	0.3437"	3-7/16"	4-3/4"	TCP200	8.53
23/64"	0.3594"	3-1/2"	4-7/8"	TCP201	9.62
3/8"	0.375"	3-5/8"	5"	TCP202	9.80
25/64"	0.3906"	3-3/4"	5-1/8"	TCP203	11.20
13/32"	0.4063"	3-7/8"	5-1/4"	TCP204	11.50
27/64"	0.4219"	3-15/16"	5-3/8"	TCP205	12.80
7/16"	0.4375"	4-1/16"	5-1/2"	TCP206	13.30
29/64"	0.4531"	4-3/16"	5-5/8"	TCP207	14.90
15/32"	0.4687"	4-5/16"	5-3/4"	TCP208	15.80
31/64"	0.4844"	4-3/8"	5-7/8"	TCP209	16.60
1/2"	0.5"	4-1/2"	6"	TCP210	16.70

CUTTING TOOLS

JOBBER DRILLS 135° (CONT.)

HX18 SERIES - WIRE GAUGE SIZE

Wire Gauge Size	Decimal Size	L2	L1	Model No.	Price /Each
#52	0.0635"	7/8"	1-7/8"	TCP237	2.20
#51	0.067"	1"	2"	TCP238	2.20
#50	0.07"	1"	2"	TCP239	2.20
#49	0.073"	1"	2"	TCP240	2.20
#48	0.076"	1"	2"	TCP241	2.20
#47	0.0785"	1"	2"	TCP242	2.20
#46	0.081"	1-1/8"	2-1/8"	TCP243	2.20
#45	0.082"	1-1/8"	2-1/8"	TCP244	2.20
#44	0.086"	1-1/8"	2-1/8"	TCP245	2.18
#43	0.089"	1-1/4"	2-1/4"	TCP246	2.18
#42	0.0935"	1-1/4"	2-1/4"	TCP247	2.20
#41	0.096"	1-3/8"	2-3/8"	TCP248	2.18
#40	0.098"	1-3/8"	2-3/8"	TCP249	2.20
#39	0.0995"	1-3/8"	2-3/8"	TCP250	2.20
#38	0.1015"	1-7/16"	2-1/2"	TCP251	2.20
#37	0.104"	1-7/16"	2-1/2"	TCP252	2.20
#36	0.1065"	1-7/16"	2-1/2"	TCP253	2.18
#35	0.11"	1-1/2"	2-5/8"	TCP254	2.20
#34	0.111"	1-1/2"	2-5/8"	TCP255	2.20
#33	0.113"	1-1/2"	2-5/8"	TCP256	2.20
#32	0.116"	1-5/8"	2-3/4"	TCP257	2.20
#31	0.12"	1-5/8"	2-3/4"	TCP258	2.20
#30	0.1285"	1-5/8"	2-3/4"	TCP259	2.22
#29	0.136"	1-3/4"	2-7/8"	TCP260	2.22
#28	0.1405"	1-3/4"	2-7/8"	TCP261	2.24
#27	0.144"	1-7/8"	3"	TCP262	2.42

HX15 SERIES - LETTER SIZE

Letter Size	Decimal Size	L2	L1	Model No.	Price /Each
A	0.234"	2-5/8"	3-7/8"	TCP211	5.24
B	0.2374"	2-3/4"	4"	TCP212	5.24
C	0.2421"	2-3/4"	4"	TCP213	5.24
D	0.2461"	2-3/4"	4"	TCP214	5.24
E	0.25"	2-3/4"	4"	TCP215	4.84
F	0.2571"	2-7/8"	4-1/8"	TCP216	5.55
G	0.261"	2-7/8"	4-1/8"	TCP217	6.26
H	0.2661"	2-7/8"	4-1/8"	TCP218	6.26
I	0.272"	2-7/8"	4-1/8"	TCP219	6.26
J	0.2772"	2-7/8"	4-1/8"	TCP220	6.71
K	0.2811"	2-15/16"	4-1/4"	TCP221	7.42
L	0.2902"	2-15/16"	4-1/4"	TCP222	7.42
M	0.2949"	3-1/16"	4-3/8"	TCP223	7.84

JOBBER DRILL SETS

A097 SERIES

- TiN coated tip that increases surface hardness and improves tool life
- Low thrust design with self centering split point that makes for easier penetration
- Material: High Speed Steel
- Manufacturing Standards: ANSI
- Point Angle: 118°
- Cutting Direction: Right Hand
- Case Included

Note: Sizes 47 to 60 and 1/16" to 5/64" have no split point or TiN tip



TCP405



No. of Pieces	Sizes	Model No.	Price /Each
29	1/16" to 1/2" by 1/64"	TCP405	222.00
15	1/16" to 1/2" by 1/32"	TCP406	127.00
13	1/16" to 1/4" by 1/64"	TCP407	46.20
60	1 to 60	TCP408	171.00
26	A to Z	TCP409	241.00
115	A to Z, 1 to 60, 1/16" to 1/2" by 1/64"	TCP410	683.00

Wire Gauge Size	Decimal Size	L2	L1	Model No.	Price /Each
#26	0.147"	1-7/8"	3"	TCP263	2.46
#25	0.1495"	1-7/8"	3"	TCP264	2.42
#24	0.152"	2"	3-1/8"	TCP265	2.51
#23	0.154"	2"	3-1/8"	TCP266	2.51
#22	0.157"	2"	3-1/8"	TCP267	2.56
#21	0.159"	2-1/8"	3-1/4"	TCP268	2.53
#20	0.161"	2-1/8"	3-1/4"	TCP269	2.75
#19	0.166"	2-1/8"	3-1/4"	TCP270	2.75
#18	0.1695"	2-1/8"	3-1/4"	TCP271	2.78
#17	0.173"	2-3/16"	3-3/8"	TCP272	3.35
#16	0.177"	2-3/16"	3-3/8"	TCP273	3.35
#15	0.18"	2-3/16"	3-3/8"	TCP274	3.35
#14	0.182"	2-3/16"	3-3/8"	TCP275	3.35
#13	0.185"	2-5/16"	3-1/2"	TCP276	3.35
#12	0.189"	2-5/16"	3-1/2"	TCP277	3.44
#11	0.191"	2-5/16"	3-1/2"	TCP278	3.42
#10	0.1935"	2-7/16"	3-5/8"	TCP279	3.69
#9	0.196"	2-7/16"	3-5/8"	TCP280	3.71
#8	0.199"	2-7/16"	3-5/8"	TCP281	3.71
#7	0.201"	2-7/16"	3-5/8"	TCP282	3.69
#6	0.204"	2-1/2"	3-3/4"	TCP283	4.22
#5	0.2055"	2-1/2"	3-3/4"	TCP284	4.22
#4	0.209"	2-1/2"	3-3/4"	TCP285	4.22
#3	0.213"	2-1/2"	3-3/4"	TCP286	4.17
#2	0.221"	2-5/8"	3-7/8"	TCP287	4.64
#1	0.228"	2-5/8"	3-7/8"	TCP288	4.58

Letter Size	Decimal Size	L2	L1	Model No.	Price /Each
N	0.302"	3-1/16"	4-3/8"	TCP224	7.84
O	0.3161"	3-3/16"	4-1/2"	TCP225	7.93
P	0.3228"	3-5/16"	4-5/8"	TCP226	8.95
Q	0.3319"	3-7/16"	4-3/4"	TCP227	8.95
R	0.339"	3-7/16"	4-3/4"	TCP228	9.59
S	0.348"	3-1/2"	4-7/8"	TCP229	10.10
T	0.358"	3-1/2"	4-7/8"	TCP230	11.50
U	0.368"	3-5/8"	5"	TCP231	11.50
V	0.3772"	3-5/8"	5"	TCP232	11.90
W	0.3858"	3-3/4"	5-1/8"	TCP233	12.20
X	0.3969"	3-3/4"	5-1/8"	TCP234	14.90
Y	0.4039"	3-7/8"	5-1/4"	TCP235	16.70
Z	0.413"	3-7/8"	5-1/4"	TCP236	17.80

JOBBER DRILL SETS

C29HX10 SERIES

- Unique surface treatment for improved wear resistance in hard ferrous alloys
- Low thrust design and self-centering split point makes for easier penetration
- Material: High Speed Steel
- Manufacturing Standards: ANSI
- Point Angle: 135°
- Finish: Purple and Gold
- Cutting Direction: Right Hand
- Case Included



No. of Pieces	Sizes	Model No.	Price /Each
29	1/16" to 1/2" by 1/64"	TCP404	233.00

JOBBER DRILL SETS

- Material: High Speed Steel
- Manufacturing Standards: ANSI
- Point Angle: 118°
- Cutting Direction: Right Hand
- Case Included

STEAM OXIDE FINISH

- Steam oxide finish reduces wear and chip welding in harder ferrous materials for increased wear resistance and lubricity

BRIGHT FINISH

- Bright finish improves chip flow in soft or non-ferrous materials



TCP412



TCP918

No of Pieces	Sizes	Manufacturer Series	Finish	Model No.	Price /Each
15	1/16" to 1/2" by 1/32"	C15R10	Steam Oxide	TCP411	115.00
29	1/16" to 1/2" by 1/64"	C29R10	Steam Oxide	TCP413	211.00
15	1/16" to 1/2" by 1/32"	C15R10P	Bright	TCP412	113.00
29	1/16" to 1/2" by 1/64"	C29R10P	Bright	TCP414	211.00

No. of Pieces	Sizes	Manufacturer Series	Model No.	Price /Each
13	1/16" to 1/4" by 1/64"	C13R10CO	TCP915	79.30
15	1/16" to 1/2" by 1/32"	C15R10CO	TCP916	226.00
21	1/16" to 3/8" by 1/64"	C21R10CO	TCP917	207.00
29	1/16" to 1/2" by 1/64"	C29R10CO	TCP918	431.00
26	A to Z	C26R15CO	TCP919	437.00
60	#1 to #60	C60R18CO	TCP920	323.00

SCREW MACHINE DRILLS 135°

- Steam oxide finish for increased wear resistance and lubricity
- Low thrust design and self-centering split point makes for easier penetration
- Material: High Speed Steel
- Point Angle: 135°
- Manufacturing Standards: ANSI
- Cutting Direction: Right Hand



R40C SERIES - FRACTIONAL SIZE

Fractional Size	Decimal Size	L2	L1	Model No.	Price /Each
1/16"	0.0625"	5/8"	1-5/8"	TCP289	2.66
5/64"	0.0781"	11/16"	1-11/16"	TCP290	2.69
3/32"	0.0938"	3/4"	1-3/4"	TCP291	2.64
7/64"	0.1094"	13/16"	1-13/16"	TCP292	2.69
1/8"	0.125"	7/8"	1-7/8"	TCP293	2.58
9/64"	0.1406"	15/16"	1-15/16"	TCP294	2.75
5/32"	0.1563"	1"	2-1/16"	TCP295	2.96
11/64"	0.1719"	1-1/16"	2-1/8"	TCP296	3.13
3/16"	0.1875"	1-1/8"	2-3/16"	TCP297	3.38
13/64"	0.2031"	1-3/16"	2-1/4"	TCP298	3.58
7/32"	0.2188"	1-1/4"	2-3/8"	TCP299	4.29
15/64"	0.2344"	1-5/16"	2-7/16"	TCP300	4.38
1/4"	0.25"	1-3/8"	2-1/2"	TCP301	4.84
17/64"	0.2656"	1-7/16"	2-5/8"	TCP302	5.57
9/32"	0.2813"	1-1/2"	2-11/16"	TCP303	5.95

Fractional Size	Decimal Size	L2	L1	Model No.	Price /Each
19/64"	0.2969"	1-9/16"	2-3/4"	TCP304	6.58
5/16"	0.3125"	1-5/8"	2-13/16"	TCP305	7.04
21/64"	0.3281"	1-11/16"	2-15/16"	TCP306	7.82
11/32"	0.3437"	1-11/16"	3"	TCP307	8.77
23/64"	0.3594"	1-3/4"	3-1/16"	TCP308	10.10
3/8"	0.375"	1-13/16"	3-1/8"	TCP309	10.50
25/64"	0.3906"	1-7/8"	3-1/4"	TCP310	12.00
13/32"	0.4063"	1-15/16"	3-5/16"	TCP311	12.30
27/64"	0.4219"	2"	3-3/8"	TCP312	13.70
7/16"	0.4375"	2-1/16"	3-7/16"	TCP313	13.80
29/64"	0.4531"	2-1/8"	3-9/16"	TCP314	16.50
15/32"	0.4687"	2-1/8"	3-5/8"	TCP315	17.60
31/64"	0.4844"	2-3/16"	3-11/16"	TCP316	18.00
1/2"	0.5"	2-1/4"	3-3/4"	TCP317	17.60

R41C SERIES - WIRE GAUGE SIZE

Wire Gauge Size	Decimal Size	L2	L1	Model No.	Price /Each
#60	0.04"	1/2"	1-3/8"	TCP318*	2.60
#59	0.041"	1/2"	1-3/8"	TCP319*	2.60
#58	0.042"	1/2"	1-3/8"	TCP320*	2.60
#57	0.043"	1/2"	1-3/8"	TCP321*	2.60
#56	0.0465"	1/2"	1-3/8"	TCP322*	2.60
#55	0.052"	5/8"	1-5/8"	TCP323*	2.60
#54	0.055"	5/8"	1-5/8"	TCP324*	2.60
#53	0.0595"	5/8"	1-5/8"	TCP325*	2.60
#52	0.0635"	11/16"	1-11/16"	TCP326	2.60
#51	0.067"	11/16"	1-11/16"	TCP327	2.60
#50	0.07"	11/16"	1-11/16"	TCP328	2.60
#49	0.073"	11/16"	1-11/16"	TCP329	2.60
#48	0.076"	11/16"	1-11/16"	TCP330	2.60
#47	0.0785"	11/16"	1-11/16"	TCP331	2.60
#46	0.081"	3/4"	1-3/4"	TCP332	2.60

Wire Gauge Size	Decimal Size	L2	L1	Model No.	Price /Each
#45	0.082"	3/4"	1-3/4"	TCP333	2.60
#44	0.086"	3/4"	1-3/4"	TCP334	2.60
#43	0.089"	3/4"	1-3/4"	TCP335	2.60
#42	0.0935"	3/4"	1-3/4"	TCP336	2.60
#41	0.096"	13/16"	1-13/16"	TCP337	2.60
#40	0.098"	13/16"	1-13/16"	TCP338	2.60
#39	0.0995"	13/16"	1-13/16"	TCP339	2.60
#38	0.1015"	13/16"	1-13/16"	TCP340	2.60
#37	0.104"	13/16"	1-13/16"	TCP341	2.60
#36	0.1065"	13/16"	1-13/16"	TCP342	2.60
#35	0.11"	7/8"	1-7/8"	TCP343	2.60
#34	0.111"	7/8"	1-7/8"	TCP344	2.60
#33	0.113"	7/8"	1-7/8"	TCP345	2.60
#32	0.116"	7/8"	1-7/8"	TCP346	2.60
#31	0.12"	7/8"	1-7/8"	TCP347	2.60

*No split point

CUTTING TOOLS

R41C SERIES - WIRE GAUGE SIZE (CONT.)

Wire Gauge Size	Decimal Size	L2	L1	Model No.	Price /Each
#30	0.1285"	15/16"	1-15/16"	TCP348	2.60
#29	0.136"	15/16"	1-15/16"	TCP349	2.60
#28	0.1405"	15/16"	1-15/16"	TCP350	2.60
#27	0.144"	1"	2-1/16"	TCP351	2.87
#26	0.147"	1"	2-1/16"	TCP352	2.87
#25	0.1495"	1"	2-1/16"	TCP353	2.87
#24	0.152"	1"	2-1/16"	TCP354	2.93
#23	0.154"	1"	2-1/16"	TCP355	2.93
#22	0.157"	1-1/16"	2-1/8"	TCP356	2.93
#21	0.159"	1-1/16"	2-1/8"	TCP357	2.93
#20	0.161"	1-1/16"	2-1/8"	TCP358	3.04
#19	0.166"	1-1/16"	2-1/8"	TCP359	3.04
#18	0.1695"	1-1/16"	2-1/8"	TCP360	3.04
#17	0.173"	1-1/8"	2-3/16"	TCP361	3.62
#16	0.177"	1-1/8"	2-3/16"	TCP362	3.62

Wire Gauge Size	Decimal Size	L2	L1	Model No.	Price /Each
#15	0.18"	1-1/8"	2-3/16"	TCP363	3.62
#14	0.182"	1-1/8"	2-3/16"	TCP364	3.62
#13	0.185"	1-1/8"	2-3/16"	TCP365	3.62
#12	0.189"	1-3/16"	2-1/4"	TCP366	3.62
#11	0.191"	1-3/16"	2-1/4"	TCP367	3.62
#10	0.1935"	1-3/16"	2-1/4"	TCP368	3.62
#9	0.196"	1-3/16"	2-1/4"	TCP369	3.62
#8	0.199"	1-3/16"	2-1/4"	TCP370	3.62
#7	0.201"	1-3/16"	2-1/4"	TCP371	3.62
#6	0.204"	1-1/4"	2-3/8"	TCP372	4.33
#5	0.2055"	1-1/4"	2-3/8"	TCP373	4.33
#4	0.209"	1-1/4"	2-3/8"	TCP374	4.33
#3	0.213"	1-1/4"	2-3/8"	TCP375	4.33
#2	0.221"	1-5/16"	2-7/16"	TCP376	4.64
#1	0.228"	1-5/16"	2-7/16"	TCP377	4.64

R42C SERIES - LETTER SIZE

Letter Size	Decimal Size	L2	L1	Model No.	Price /Each
A	0.234"	1-5/16"	2-7/16"	TCP378	5.47
B	0.2374"	1-3/8"	2-1/2"	TCP379	5.47
C	0.2421"	1-3/8"	2-1/2"	TCP380	5.47
D	0.2461"	1-3/8"	2-1/2"	TCP381	5.47
E	0.25"	1-3/8"	2-1/2"	TCP382	5.84
F	0.2571"	1-7/16"	2-5/8"	TCP383	6.06
G	0.261"	1-7/16"	2-5/8"	TCP384	6.42
H	0.2661"	1-1/2"	2-11/16"	TCP385	6.42
I	0.272"	1-1/2"	2-11/16"	TCP386	6.42
J	0.2772"	1-1/2"	2-11/16"	TCP387	6.88
K	0.2811"	1-1/2"	2-11/16"	TCP388	7.42
L	0.2992"	1-9/16"	2-3/4"	TCP389	7.42
M	0.2949"	1-9/16"	2-3/4"	TCP390	8.08

Letter Size	Decimal Size	L2	L1	Model No.	Price /Each
N	0.302"	1-5/8"	2-13/16"	TCP391	8.08
O	0.3161"	1-11/16"	2-15/16"	TCP392	8.15
P	0.3228"	1-11/16"	2-15/16"	TCP393	9.13
Q	0.3319"	1-11/16"	3"	TCP394	9.13
R	0.339"	1-11/16"	3"	TCP395	9.28
S	0.348"	1-3/4"	3-1/16"	TCP396	10.50
T	0.358"	1-3/4"	3-1/16"	TCP397	12.20
U	0.368"	1-13/16"	3-1/8"	TCP398	12.20
V	0.3772"	1-7/8"	3-1/4"	TCP399	13.00
W	0.3858"	1-7/8"	3-1/4"	TCP400	13.70
X	0.3969"	1-15/16"	3-5/16"	TCP401	15.90
Y	0.4039"	1-15/16"	3-5/16"	TCP402	18.80
Z	0.413"	2"	3-3/8"	TCP403	18.80

SILVER & DEMING DRILLS 118°

R56 SERIES

- Steam oxide finish for increased wear resistance and lubricity
- Material: High Speed Steel
- Point Angle: 118°
- Manufacturing Standards: ANSI
- Shank Size: 1/2"
- Cutting Direction: Right Hand

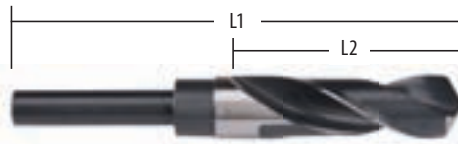

Fractional Size	Decimal Size	L2	L1	Model No.	Price /Each
33/64"	0.5156"	3"	6"	TCQ496	38.40
17/32"	0.5313"	3"	6"	TCQ497	37.40
35/64"	0.5469"	3"	6"	TCQ498	40.90
9/16"	0.5625"	3"	6"	TCQ499	39.80
37/64"	0.5781"	3"	6"	TCQ500	43.90
19/32"	0.5937"	3"	6"	TCQ501	42.80
5/8"	0.625"	3"	6"	TCQ502	44.80
41/64"	0.6406"	3"	6"	TCQ503	49.20
21/32"	0.6563"	3"	6"	TCQ504	47.80
43/64"	0.6719"	3"	6"	TCQ505	51.10
11/16"	0.6875"	3"	6"	TCQ506	49.70
45/64"	0.7031"	3"	6"	TCQ507	51.70
23/32"	0.7188"	3"	6"	TCQ508	50.40
47/64"	0.7344"	3"	6"	TCQ509	56.40
3/4"	0.75"	3"	6"	TCQ510	54.80
49/64"	0.7656"	3"	6"	TCQ511	60.10
25/32"	0.7813"	3"	6"	TCQ512	58.50
51/64"	0.7969"	3"	6"	TCQ513	70.00
13/16"	0.8125"	3"	6"	TCQ514	61.50
53/64"	0.8281"	3"	6"	TCQ515	72.60
27/32"	0.8438"	3"	6"	TCQ516	63.60
55/64"	0.8594"	3"	6"	TCQ517	75.10
7/8"	0.875"	3"	6"	TCQ518	66.20
57/64"	0.8906"	3"	6"	TCQ519	78.90
29/32"	0.9063"	3"	6"	TCQ520	68.80
59/64"	0.9219"	3"	6"	TCQ521	84.70
15/16"	0.9375"	3"	6"	TCQ522	73.20
61/64"	0.9531"	3"	6"	TCQ523	89.10

Fractional Size	Decimal Size	L2	L1	Model No.	Price /Each
31/32"	0.9688"	3"	6"	TCQ524	77.70
63/64"	0.9844"	3"	6"	TCQ525	99.90
1"	1"	3"	6"	TCQ526	86.60
1-1/64"	1.0156"	3"	6"	TCQ527	120.00
1-1/32"	1.0312"	3"	6"	TCQ528	106.00
1-3/64"	1.0469"	3"	6"	TCQ529	109.00
1-1/16"	1.0625"	3"	6"	TCQ530	102.00
1-5/64"	1.0781"	3"	6"	TCQ531	112.00
1-3/32"	1.0937"	3"	6"	TCQ532	113.00
1-7/64"	1.1094"	3"	6"	TCQ533	121.00
1-1/8"	1.125"	3"	6"	TCQ534	115.00
1-9/64"	1.1406"	3"	6"	TCQ535	124.00
1-5/32"	1.1563"	3"	6"	TCQ536	120.00
1-11/64"	1.1719"	3"	6"	TCQ537	132.00
1-3/16"	1.1875"	3"	6"	TCQ538	127.00
1-13/64"	1.2031"	3"	6"	TCQ539	142.00
1-7/32"	1.2187"	3"	6"	TCQ540	141.00
1-15/64"	1.2344"	3"	6"	TCQ541	146.00
1-1/4"	1.25"	3"	6"	TCQ542	140.00
1-9/32"	1.2813"	3"	6"	TCQ543	164.00
1-5/16"	1.3125"	3"	6"	TCQ544	174.00
1-11/32"	1.3437"	3"	6"	TCQ545	190.00
1-3/8"	1.375"	3"	6"	TCQ546	200.00
1-13/32"	1.4063"	3"	6"	TCQ547	234.00
1-7/16"	1.4375"	3"	6"	TCQ548	220.00
1-15/32"	1.4687"	3"	6"	TCQ549	257.00
1-1/2"	1.5"	3"	6"	TCQ550	243.00

TAPER SHANK DRILL 118°

209 SERIES

- Steam oxide finish increases tool life and lubricity
- Material: High Speed Steel
- Point Angle: 118°
- Manufacturing Standards: ANSI
- Cutting Direction: Right Hand



Fractional Size	Decimal Size	L2	L1	Morse Taper Shank No.	Model No.	Price /Each
1/8"	0.125"	1-7/8"	5-1/8"	#1	TCP415	20.60
9/64"	0.1406"	2-1/8"	5-3/8"	#1	TCP416	21.60
5/32"	0.1562"	2-1/8"	5-3/8"	#1	TCP417	20.80
11/64"	0.1718"	2-1/2"	5-3/4"	#1	TCP418	21.60
3/16"	0.1875"	2-1/2"	5-3/4"	#1	TCP419	14.60
13/64"	0.2031"	2-3/4"	6"	#1	TCP420	16.40
7/32"	0.2187"	2-3/4"	6"	#1	TCP421	15.80
15/64"	0.2343"	2-7/8"	6-1/8"	#1	TCP422	18.80
1/4"	0.25"	2-7/8"	6-1/8"	#1	TCP423	16.30
17/64"	0.2656"	3"	6-1/4"	#1	TCP424	18.20
9/32"	0.2812"	3"	6-1/4"	#1	TCP425	17.40
19/64"	0.2968"	3-1/8"	6-3/8"	#1	TCP426	22.50
5/16"	0.3125"	3-1/8"	6-3/8"	#1	TCP427	17.40
21/64"	0.3281"	3-1/4"	6-1/2"	#1	TCP428	24.10
11/32"	0.3437"	3-1/4"	6-1/2"	#1	TCP429	25.20
23/64"	0.3593"	3-1/2"	6-3/4"	#1	TCP430	27.90
3/8"	0.375"	3-1/2"	6-3/4"	#1	TCP431	26.60
25/64"	0.3906"	3-5/8"	7"	#1	TCP432	28.90
13/32"	0.4062"	3-5/8"	7"	#1	TCP433	26.90
27/64"	0.4218"	3-7/8"	7-1/4"	#1	TCP434	30.90
7/16"	0.4375"	3-7/8"	7-1/4"	#1	TCP435	29.70
29/64"	0.4531"	4-1/8"	7-1/2"	#1	TCP436	33.90
15/32"	0.4687"	4-1/8"	7-1/2"	#1	TCP437	34.10
31/64"	0.4843"	4-3/8"	8-1/4"	#2	TCP438	38.40
1/2"	0.5"	4-3/8"	8-1/4"	#2	TCP439	33.90
33/64"	0.5156"	4-5/8"	8-1/2"	#2	TCP440	40.60
17/32"	0.5312"	4-5/8"	8-1/2"	#2	TCP441	37.90
35/64"	0.5468"	4-7/8"	8-3/4"	#2	TCP442	44.20
9/16"	0.5625"	4-7/8"	8-3/4"	#2	TCP443	41.40
37/64"	0.5781"	4-7/8"	8-3/4"	#2	TCP444	47.00
19/32"	0.5937"	4-7/8"	8-3/4"	#2	TCP445	44.50
39/64"	0.6093"	4-7/8"	8-3/4"	#2	TCP446	49.10
5/8"	0.625"	4-7/8"	8-3/4"	#2	TCP447	45.20
41/64"	0.6406"	5-1/8"	9"	#2	TCP448	54.20
21/32"	0.6562"	5-1/8"	9"	#2	TCP449	50.40
43/64"	0.6718"	5-3/8"	9-1/4"	#2	TCP450	57.80
11/16"	0.6875"	5-3/8"	9-1/4"	#2	TCP451	52.50
45/64"	0.7031"	5-5/8"	9-1/2"	#2	TCP452	60.00
23/32"	0.7187"	5-5/8"	9-1/2"	#2	TCP453	56.20
47/64"	0.7343"	5-7/8"	9-3/4"	#2	TCP454	63.80
3/4"	0.75"	5-7/8"	9-3/4"	#2	TCP455	61.10
49/64"	0.7656"	6"	9-7/8"	#2	TCP456	76.90
25/32"	0.7812"	6"	9-7/8"	#2	TCP457	74.20
51/64"	0.7968"	6-1/8"	10-3/4"	#3	TCP458	84.60
13/16"	0.8125"	6-1/8"	10-3/4"	#3	TCP459	75.80
53/64"	0.8281"	6-1/8"	10-3/4"	#3	TCP460	88.40
27/32"	0.8437"	6-1/8"	10-3/4"	#3	TCP461	81.80
55/64"	0.8593"	6-1/8"	10-3/4"	#3	TCP462	91.70
7/8"	0.875"	6-1/8"	10-3/4"	#3	TCP463	84.00
57/64"	0.8906"	6-1/8"	10-3/4"	#3	TCP464	93.30
29/32"	0.9062"	6-1/8"	10-3/4"	#3	TCP465	90.00
59/64"	0.9218"	6-1/8"	10-3/4"	#3	TCP466	94.40
15/16"	0.9375"	6-1/8"	10-3/4"	#3	TCP467	84.60

Fractional Size	Decimal Size	L2	L1	Morse Taper Shank No.	Model No.	Price /Each
61/64"	0.9531"	6-3/8"	11"	#3	TCP468	97.10
31/32"	0.9687"	6-3/8"	11"	#3	TCP469	92.80
63/64"	0.9843"	6-3/8"	11"	#3	TCP470	103.00
1"	1"	6-3/8"	11"	#3	TCP471	94.40
1-1/64"	1.0156"	6-1/2"	11-1/8"	#3	TCP472	117.00
1-1/32"	1.0312"	6-1/2"	11-1/8"	#3	TCP473	104.00
1-3/64"	1.0468"	6-5/8"	11-1/4"	#3	TCP474	123.00
1-1/16"	1.0625"	6-5/8"	11-1/4"	#3	TCP475	109.00
1-5/64"	1.0781"	6-7/8"	12-1/2"	#4	TCP476	142.00
1-3/32"	1.0937"	6-7/8"	12-1/2"	#4	TCP477	128.00
1-7/64"	1.1093"	7-1/8"	12-3/4"	#4	TCP478	148.00
1-1/8"	1.125"	7-1/8"	12-3/4"	#4	TCP479	133.00
1-9/64"	1.1406"	7-1/4"	12-7/8"	#4	TCP480	156.00
1-5/32"	1.1562"	7-1/4"	12-7/8"	#4	TCP481	139.00
1-11/64"	1.1718"	7-3/8"	13"	#4	TCP482	158.00
1-3/16"	1.1875"	7-3/8"	13"	#4	TCP483	145.00
1-13/64"	1.2031"	7-1/2"	13-1/8"	#4	TCP484	170.00
1-7/32"	1.2187"	7-1/2"	13-1/8"	#4	TCP485	156.00
1-15/64"	1.2343"	7-7/8"	13-1/2"	#4	TCP486	184.00
1-1/4"	1.25"	7-7/8"	13-1/2"	#4	TCP487	164.00
1-17/64"	1.2656"	8-1/2"	14-1/8"	#4	TCP488	213.00
1-9/32"	1.2812"	8-1/2"	14-1/8"	#4	TCP489	204.00
1-19/64"	1.2968"	8-5/8"	14-1/4"	#4	TCP490	227.00
1-5/16"	1.3125"	8-5/8"	14-1/4"	#4	TCP491	205.00
1-21/64"	1.3281"	8-3/4"	14-3/8"	#4	TCP492	234.00
1-11/32"	1.3437"	8-3/4"	14-3/8"	#4	TCP493	219.00
1-23/64"	1.3593"	8-7/8"	14-1/2"	#4	TCP494	240.00
1-3/8"	0.375"	8-7/8"	14-1/2"	#4	TCP495	220.00
1-25/64"	1.3906"	9"	14-5/8"	#4	TCP496	247.00
1-13/32"	1.4062"	9"	14-5/8"	#4	TCP497	237.00
1-27/64"	1.4218"	9-1/8"	14-3/4"	#4	TCP498	255.00
1-7/16"	1.4375"	9-1/8"	14-3/4"	#4	TCP499	237.00
1-29/64"	1.4531"	9-1/4"	14-7/8"	#4	TCP500	265.00
1-15/32"	1.4687"	9-1/4"	14-7/8"	#4	TCP501	256.00
1-31/64"	1.4843"	9-3/8"	15"	#4	TCP502	276.00
1-1/2"	1.5"	9-3/8"	15"	#4	TCP503	253.00
1-17/32"	1.5312"	9-3/8"	16-3/8"	#5	TCP504	295.00
1-9/16"	1.5625"	9-5/8"	16-5/8"	#5	TCP505	306.00
1-19/32"	1.5937"	9-7/8"	16-7/8"	#5	TCP506	334.00
1-5/8"	1.625"	10"	17"	#5	TCP507	330.00
1-11/16"	1.6875"	10-1/8"	17-1/8"	#5	TCP509	364.00
1-23/32"	1.7187"	10-1/8"	17-1/8"	#5	TCP510	385.00
1-3/4"	1.75"	10-1/8"	17-1/8"	#5	TCP511	390.00
1-25/32"	1.7812"	10-1/8"	17-1/8"	#5	TCP512	409.00
1-13/16"	1.8125"	10-1/8"	17-1/8"	#5	TCP513	415.00
1-27/32"	1.8437"	10-1/8"	17-1/8"	#5	TCP514	438.00
1-7/8"	1.875"	10-3/8"	17-3/8"	#5	TCP515	435.00
1-29/32"	1.9062"	10-3/8"	17-3/8"	#5	TCP516	458.00
1-15/16"	1.9375"	10-3/8"	17-3/8"	#5	TCP517	468.00
1-31/32"	1.9687"	10-3/8"	17-3/8"	#5	TCP518	483.00
2"	2"	10-3/8"	17-3/8"	#5	TCP519	486.00

See pages 1148 & 1149
for Cutting Fluids



CUTTING TOOLS

HAND TAPS

- Versatile tap that can be used for both hand or machine tapping in a wide variety of materials
- Bright finish improves chip flow in soft or non-ferrous materials
- Material: High Speed Steel
- Manufacturing Standards: ANSI
- Cutting Direction: Right Hand
- **1500-1500S series:** Fractional sizes
- **1528-1528S series:** Machine screw sizes

Note: Sizes 0-80 through 3/8"-24 have a male centre on the thread end
 Sizes 7/16"-14 through 1-1/2"-12 have a female centre/flat end

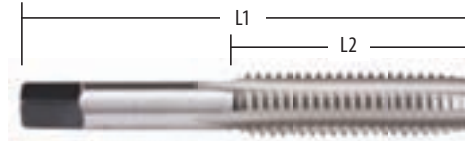

UNION BUTTERFIELD®

Thread Size	Thread Form	No. of Flutes	L2	L1	Limits	Taper Model No.	Plug Model No.	Bottoming Model No.	Price /Each	Sets	Price /Each
0-80	Unified Fine	2	5/16"	1-5/8"	H1	TCQ219	TCQ277	TCQ361	21.40	TCQ441	64.40
0-80	Unified Fine	2	5/16"	1-5/8"	H2	-	TCQ278	TCQ362	21.40	-	-
1-64	Unified Coarse	2	3/8"	1-11/16"	H1	TCQ220	TCQ279	TCQ363	20.00	TCQ442	60.10
1-72	Unified Fine	2	3/8"	1-11/16"	H1	TCQ221	TCQ280	TCQ364	20.00	TCQ443	60.10
2-56	Unified Coarse	2	7/16"	1-3/4"	H2	-	TCQ281	TCQ365	18.70	-	-
2-56	Unified Coarse	3	7/16"	1-3/4"	H1	TCQ222	TCQ282	TCQ366	18.70	-	-
2-56	Unified Coarse	3	7/16"	1-3/4"	H2	TCQ223	TCQ283	TCQ367	17.60	TCQ444	52.70
2-64	Unified Fine	3	7/16"	1-3/4"	H2	-	-	-	-	TCQ445	56.10
3-48	Unified Coarse	2	1/2"	1-13/16"	H2	-	TCQ284	-	14.80	-	-
3-48	Unified Coarse	3	1/2"	1-13/16"	H2	TCQ224	TCQ285	TCQ368	13.20	TCQ446	39.60
3-56	Unified Fine	3	1/2"	1-13/16"	H2	TCQ225	TCQ286	TCQ369	14.80	TCQ447	44.50
4-40	Unified Coarse	2	9/16"	1-7/8"	H2	-	TCQ287	TCQ370	11.70	-	-
4-40	Unified Coarse	3	9/16"	1-7/8"	H1	TCQ226	TCQ288	TCQ371	11.70	-	-
4-40	Unified Coarse	3	9/16"	1-7/8"	H2	TCQ227	TCQ289	TCQ372	11.00	TCQ448	32.90
4-48	Unified Fine	3	9/16"	1-7/8"	H2	TCQ228	TCQ290	TCQ373	11.70	TCQ449	35.20
4-36	Unified Special	3	9/16"	1-7/8"	H2	-	-	-	-	TCQ450	35.20
5-40	Unified Coarse	3	5/8"	1-15/16"	H2	TCQ229	TCQ291	TCQ374	11.00	TCQ451	32.90
5-44	Unified Fine	3	5/8"	1-15/16"	H2	TCQ230	TCQ292	TCQ375	11.70	TCQ452	35.20
6-32	Unified Coarse	2	11/16"	2"	H2	-	TCQ293	TCQ376	10.30	-	-
6-32	Unified Coarse	2	11/16"	2"	H3	-	TCQ294	TCQ377	8.80	-	-
6-32	Unified Coarse	3	11/16"	2"	H1	TCQ231	TCQ295	TCQ378	10.30	-	-
6-32	Unified Coarse	3	11/16"	2"	H2	TCQ232	TCQ296	TCQ379	8.80	TCQ453	26.40
6-32	Unified Coarse	3	11/16"	2"	H3	TCQ233	TCQ297	TCQ380	8.37	TCQ454	25.10
6-40	Unified Fine	3	11/16"	2"	H2	TCQ234	TCQ298	TCQ381	8.80	TCQ455	26.40
8-32	Unified Coarse	2	3/4"	2-1/8"	H2	-	TCQ299	TCQ382	10.30	-	-
8-32	Unified Coarse	2	3/4"	2-1/8"	H3	-	TCQ300	TCQ383	8.80	-	-
8-32	Unified Coarse	3	3/4"	2-1/8"	H2	-	TCQ301	TCQ384	10.30	-	-
8-32	Unified Coarse	3	3/4"	2-1/8"	H3	-	TCQ302	TCQ385	8.80	-	-
8-32	Unified Coarse	4	3/4"	2-1/8"	H1	-	TCQ303	-	10.30	-	-
8-32	Unified Coarse	4	3/4"	2-1/8"	H2	TCQ235	TCQ304	TCQ386	8.80	TCQ456	26.40
8-32	Unified Coarse	4	3/4"	2-1/8"	H3	TCQ236	TCQ305	TCQ387	8.55	TCQ457	25.70
8-36	Unified Fine	4	3/4"	2-1/8"	H2	TCQ237	TCQ306	TCQ388	8.80	TCQ458	26.40
10-24	Unified Coarse	2	7/8"	2-3/8"	H2	-	TCQ307	TCQ389	10.30	-	-
10-24	Unified Coarse	2	7/8"	2-3/8"	H3	-	TCQ308	TCQ390	9.06	-	-
10-24	Unified Coarse	3	7/8"	2-3/8"	H2	-	TCQ309	-	10.30	-	-
10-24	Unified Coarse	3	7/8"	2-3/8"	H3	-	TCQ310	TCQ391	9.06	-	-
10-24	Unified Coarse	4	7/8"	2-3/8"	H1	-	TCQ311	-	9.06	-	-
10-24	Unified Coarse	4	7/8"	2-3/8"	H2	TCQ238	TCQ312	TCQ392	9.06	TCQ459	27.20
10-24	Unified Coarse	4	7/8"	2-3/8"	H3	TCQ239	TCQ313	TCQ393	9.06	TCQ460	27.20
10-32	Unified Fine	2	7/8"	2-3/8"	H2	-	TCQ314	TCQ394	10.30	-	-
10-32	Unified Fine	2	7/8"	2-3/8"	H3	-	TCQ315	TCQ395	9.06	-	-
10-32	Unified Fine	3	7/8"	2-3/8"	H2	-	TCQ316	TCQ396	10.30	-	-
10-32	Unified Fine	3	7/8"	2-3/8"	H3	-	TCQ317	TCQ397	9.06	-	-
10-32	Unified Fine	4	7/8"	2-3/8"	H2	TCQ240	TCQ318	TCQ398	9.06	TCQ461	27.20
10-32	Unified Fine	4	7/8"	2-3/8"	H3	TCQ241	TCQ319	TCQ399	9.06	TCQ462	27.20
12-24	Unified Coarse	4	15/16"	2-3/8"	H3	TCQ242	TCQ320	TCQ400	9.31	TCQ463	27.90
12-28	Unified Fine	4	15/16"	2-3/8"	H3	TCQ243	TCQ321	TCQ401	10.30	TCQ464	30.80
1/4"-20	Unified Coarse	4	1"	2-1/2"	H1	TCQ244	TCQ322	TCQ402	11.90	-	-
1/4"-20	Unified Coarse	4	1"	2-1/2"	H2	TCQ245	TCQ323	TCQ403	11.30	-	-
1/4"-20	Unified Coarse	4	1"	2-1/2"	H3	TCQ246	TCQ324	TCQ404	9.57	TCQ465	28.60
1/4"-20	Unified Coarse	4	1"	2-1/2"	H5	-	TCQ325	TCQ405	11.30	-	-
1/4"-28	Unified Fine	4	1"	2-1/2"	H2	-	TCQ326	TCQ406	11.90	-	-
1/4"-28	Unified Fine	4	1"	2-1/2"	H3	TCQ247	TCQ327	TCQ407	9.57	TCQ466	28.60
1/4"-28	Unified Fine	4	1"	2-1/2"	H5	-	TCQ328	TCQ408	11.90	-	-
5/16"-18	Unified Coarse	4	1-1/8"	2-23/32"	H2	TCQ248	TCQ329	TCQ409	13.10	-	-
5/16"-18	Unified Coarse	4	1-1/8"	2-23/32"	H3	TCQ249	TCQ330	TCQ410	11.50	TCQ467	34.60
5/16"-24	Unified Fine	4	1-1/8"	2-23/32"	H3	TCQ250	TCQ331	TCQ411	11.50	TCQ468	34.60
3/8"-16	Unified Coarse	4	1-1/4"	2-15/16"	H2	TCQ251	TCQ332	TCQ412	14.80	-	-
3/8"-16	Unified Coarse	4	1-1/4"	2-15/16"	H3	TCQ252	TCQ333	TCQ413	13.10	TCQ469	39.30
3/8"-16	Unified Coarse	4	1-1/4"	2-15/16"	H5	-	TCQ334	TCQ414	14.80	-	-
3/8"-24	Unified Fine	4	1-1/4"	2-15/16"	H3	TCQ253	TCQ335	TCQ415	13.10	TCQ470	39.30
7/16"-14	Unified Coarse	4	1-7/16"	3-5/32"	H3	TCQ254	TCQ336	TCQ416	22.60	TCQ471	67.70
7/16"-20	Unified Fine	4	1-7/16"	3-5/32"	H3	TCQ255	TCQ337	TCQ417	22.60	TCQ472	67.70
1/2"-13	Unified Coarse	4	1-21/32"	3-3/8"	H2	-	TCQ338	TCQ418	29.20	-	-
1/2"-13	Unified Coarse	4	1-21/32"	3-3/8"	H3	TCQ256	TCQ339	TCQ419	23.60	TCQ473	70.60
1/2"-13	Unified Coarse	4	1-21/32"	3-3/8"	H5	-	TCQ340	TCQ420	29.20	-	-
1/2"-20	Unified Fine	4	1-21/32"	3-3/8"	H3	TCQ257	TCQ341	TCQ421	27.00	TCQ474	80.80
9/16"-12	Unified Coarse	4	1-21/32"	3-19/32"	H3	TCQ258	TCQ342	TCQ422	39.70	TCQ475	119.00

HAND TAPS (CONT.)

Thread Size	Thread Form	No. of Flutes	L2	L1	Limits	Taper Model No.	Plug Model No.	Bottoming Model No.	Price /Each	Sets	Price /Each
9/16"-18	Unified Fine	4	1-21/32"	3-19/32"	H3	TCQ259	TCQ343	TCQ423	39.70	TCQ476	119.00
5/8"-11	Unified Coarse	4	1-13/16"	3-13/16"	H3	TCQ260	TCQ344	TCQ424	47.90	TCQ477	144.00
5/8"-18	Unified Fine	4	1-13/16"	3-13/16"	H3	TCQ261	TCQ345	TCQ425	47.90	TCQ478	144.00
11/16"-11	Unified Special	4	1-13/16"	4-1/32"	H3	-	-	-	-	TCQ479	179.00
11/16"-16	Unified Special	4	1-13/16"	4-1/32"	H3	-	-	-	-	TCQ480	179.00
3/4"-10	Unified Coarse	4	2"	4-1/4"	H3	TCQ262	TCQ346	TCQ426	67.70	TCQ481	203.00
3/4"-16	Unified Fine	4	2"	4-1/4"	H3	TCQ263	TCQ347	TCQ427	67.70	TCQ482	203.00
7/8"-9	Unified Coarse	4	2-7/32"	4-11/16"	H4	TCQ264	TCQ348	TCQ428	93.10	TCQ483	279.00
7/8"-14	Unified Fine	4	2-7/32"	4-11/16"	H4	TCQ265	TCQ349	TCQ429	93.10	TCQ484	279.00
1"-8	Unified Coarse	4	2-1/2"	5-1/8"	H4	TCQ266	TCQ350	TCQ430	124.00	TCQ485	372.00
1"-12	Unified Fine	4	2-1/2"	5-1/8"	H4	TCQ267	TCQ351	TCQ431	126.00	TCQ486	377.00
1"-14	Unified Special	4	2-1/2"	5-1/8"	H4	TCQ268	TCQ352	TCQ432	124.00	TCQ487	372.00
1-1/8"-7	Unified Coarse	4	2-9/16"	5-7/16"	H4	TCQ269	TCQ353	TCQ433	199.00	TCQ488	597.00
1-1/8"-12	Unified Fine	4	2-9/16"	5-7/16"	H4	TCQ270	TCQ354	TCQ434	215.00	TCQ489	645.00
1-1/4"-7	Unified Coarse	4	2-9/16"	5-3/4"	H4	TCQ271	TCQ355	TCQ435	263.00	TCQ490	787.00
1-1/4"-12	Unified Fine	6	2-9/16"	5-3/4"	H4	TCQ272	TCQ356	TCQ436	267.00	TCQ491	800.00
1-3/8"-6	Unified Coarse	4	3"	6-1/16"	H4	TCQ273	TCQ357	TCQ437	331.00	TCQ492	990.00
1-3/8"-12	Unified Fine	6	3"	6-1/16"	H4	TCQ274	TCQ358	TCQ438	335.00	TCQ493	1003.00
1-1/2"-6	Unified Coarse	4	3"	6-3/8"	H4	TCQ275	TCQ359	TCQ439	382.00	TCQ494	1146.00
1-1/2"-12	Unified Fine	6	3"	6-3/8"	H4	TCQ276	TCQ360	TCQ440	389.00	TCQ495	1169.00

HAND TAPS

E500 SERIES

- Versatile tap that can be used for both hand or machine tapping in a wide variety of materials
- Bright finish improves chip flow in soft or non-ferrous materials
- Material: High Speed Steel
- Manufacturing Standards: ISO 529
- Tolerance: 6H
- Cutting Direction: Right Hand

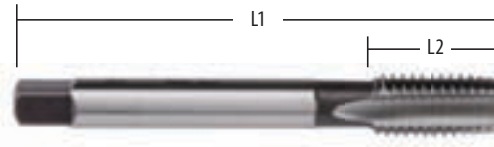

Note: ISO shank and square dimensions require metric holders

Thread Size	Thread Form	No. of Flutes	L2	L1	Taper Model No.	Plug Model No.	Bottoming Model No.	Price /Each	Sets	Price /Each
M1x0.25	Metric Coarse	2	4.5 mm	38 mm	TCQ069	TCQ111	TCQ153	85.50	-	-
M1.2x0.25	Metric Coarse	2	4.5 mm	38 mm	TCQ070	TCQ112	TCQ154	74.00	-	-
M1.4x0.3	Metric Coarse	2	6 mm	40 mm	TCQ071	TCQ113	TCQ155	57.90	-	-
M1.6x0.35	Metric Coarse	2	8 mm	41 mm	TCQ072	TCQ114	TCQ156	33.20	TCQ197	98.90
M1.7x0.35	Metric Coarse	2	8 mm	41 mm	TCQ073	TCQ115	TCQ157	39.40	TCQ198	118.00
M1.8x0.35	Metric Coarse	2	8 mm	41 mm	TCQ074	TCQ116	TCQ158	39.00	-	-
M2x0.4	Metric Coarse	3	8 mm	41 mm	TCQ078	TCQ120	TCQ162	25.40	TCQ202	76.00
M2x0.45	Metric Coarse	3	8 mm	41 mm	TCQ079	TCQ121	TCQ163	67.10	-	-
M2.2x0.45	Metric Coarse	3	9.5 mm	44.5 mm	TCQ080	TCQ122	TCQ164	32.70	-	-
M2.3x0.45	Metric Coarse	3	9.5 mm	44.5 mm	TCQ081	TCQ123	TCQ165	30.50	-	-
M2.5x0.45	Metric Coarse	3	9.5 mm	44.5 mm	TCQ082	TCQ124	TCQ166	24.60	TCQ203	73.40
M2.6x0.45	Metric Coarse	3	9.5 mm	44.5 mm	TCQ083	TCQ125	TCQ167	32.30	-	-
M3x0.5	Metric Coarse	3	12.5 mm	48 mm	TCQ084	TCQ126	TCQ168	11.90	TCQ204	35.60
M3x0.6	Metric Coarse	3	12.5 mm	48 mm	TCQ085	TCQ127	TCQ169	22.60	-	-
M3.5x0.6	Metric Coarse	3	14 mm	50 mm	TCQ086	TCQ128	TCQ170	10.80	TCQ205	32.30
M4x0.7	Metric Coarse	3	14 mm	53 mm	TCQ087	TCQ129	TCQ171	10.80	TCQ206	32.30
M4x0.75	Metric Coarse	3	14 mm	53 mm	TCQ088	TCQ130	TCQ172	22.10	-	-
M4.5x0.75	Metric Coarse	3	9.5 mm	53 mm	TCQ089	TCQ131	TCQ173	10.80	TCQ207	32.30
M5x0.8	Metric Coarse	3	11 mm	58 mm	TCQ090	TCQ132	TCQ174	10.80	TCQ208	32.30
M5x0.9	Metric Coarse	3	11 mm	58 mm	TCQ091	TCQ133	TCQ175	23.70	-	-
M5.5x0.9	Metric Coarse	3	12 mm	62 mm	TCQ092	TCQ134	TCQ176	11.60	-	-
M6x1	Metric Coarse	3	13 mm	66 mm	TCQ093	TCQ135	TCQ177	11.40	TCQ209	34.20
M7x1	Metric Coarse	3	13 mm	66 mm	TCQ094	TCQ136	TCQ178	12.40	TCQ210	37.10
M8x1.25	Metric Coarse	3	16 mm	72 mm	TCQ095	TCQ137	TCQ179	12.40	TCQ211	37.10
M9x1.25	Metric Coarse	3	16 mm	72 mm	TCQ096	TCQ138	TCQ180	16.10	TCQ212	48.40
M10x1.5	Metric Coarse	3	18 mm	80 mm	TCQ075	TCQ117	TCQ159	23.30	TCQ199	70.00
M11x1.5	Metric Coarse	3	19 mm	85 mm	TCQ076	TCQ118	TCQ160	23.30	TCQ200	70.00
M12x1.75	Metric Coarse	3	22 mm	89 mm	TCQ077	TCQ119	TCQ161	27.50	TCQ201	82.10
M14x2	Metric Coarse	4	24 mm	95 mm	TCQ097	TCQ139	TCQ181	40.90	TCQ213	122.00
M16x2	Metric Coarse	4	24 mm	102 mm	TCQ098	TCQ140	TCQ182	50.10	TCQ214	150.00
M18x2.5	Metric Coarse	4	29 mm	112 mm	TCQ099	TCQ141	TCQ183	67.30	TCQ215	203.00
M20x2.5	Metric Coarse	4	29 mm	112 mm	TCQ100	TCQ142	TCQ184	91.50	TCQ216	275.00
M22x2.5	Metric Coarse	4	29 mm	118 mm	TCQ101	TCQ143	TCQ185	100.00	TCQ217	301.00
M24x3	Metric Coarse	4	35 mm	130 mm	TCQ102	TCQ144	TCQ186	122.00	TCQ218	367.00
M27x3	Metric Coarse	4	35 mm	135 mm	TCQ103	TCQ145	TCQ187	216.00	-	-
M30x3.5	Metric Coarse	4	41 mm	138 mm	TCQ104	TCQ146	TCQ188	284.00	-	-
M33x3.5	Metric Coarse	4	41 mm	151 mm	TCQ105	TCQ147	TCQ189	371.00	-	-
M36x4	Metric Coarse	4	47 mm	162 mm	TCQ106	TCQ148	TCQ190	415.00	-	-
M39x4	Metric Coarse	4	47 mm	170 mm	TCQ107	TCQ149	TCQ191	457.00	-	-
M42x4.5	Metric Coarse	6	53 mm	170 mm	TCQ108	TCQ150	TCQ192	581.00	-	-
M45x4.5	Metric Coarse	6	54 mm	187 mm	TCQ109	TCQ151	TCQ193	795.00	-	-
M48x5	Metric Coarse	6	60 mm	187 mm	TCQ110	TCQ152	TCQ194	848.00	-	-
M52x5	Metric Coarse	6	60 mm	200 mm	-	-	TCQ195	967.00	-	-
M56x5.5	Metric Coarse	6	60 mm	200 mm	-	-	TCQ196	1059.00	-	-

CUTTING TOOLS



SPIRAL POINT TAPS

- Material: High Speed Cobalt
- Manufacturing Standards: ANSI
- Cutting Direction: Right Hand
- Chamfer Type: Plug
- Tolerance: 3B

EO25 & EO35 SERIES - BRIGHT FLUTE & BRONZE BODY FINISH

- Premium substrate for through hole tapping in tough or abrasive materials
- Bronze oxide body and shank reduces rust and corrosion
- Bright finish flutes improve chip flow in soft or non-ferrous materials

Note: Reinforced shanks: Sizes 6-32 to 3/8"-24
Reduced shanks: Sizes 7/16"-14 to 1"-14

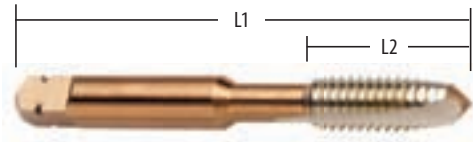

Thread Size	Thread Form	No. of Flutes	L2	L1	Limits	Model No.	Price /Each
6-32	Unified Coarse	2	0.2610"	2"	H2	TCP825	13.40
6-40	Unified Fine	2	0.261"	2"	H2	TCP868	15.10
8-32	Unified Coarse	2	0.2484"	2-1/8"	H2	TCP826	13.40
8-36	Unified Fine	2	0.2484"	2-1/8"	H2	TCP869	15.10
10-24	Unified Coarse	2	0.4303"	2-3/8"	H3	TCP827	13.40
10-32	Unified Fine	3	0.4303"	2-3/8"	H2	TCP870	13.40
12-24	Unified Coarse	3	0.4173"	2-3/8"	H3	TCP828	15.10
1/4"-20	Unified Coarse	2	0.5075"	2-1/2"	H3	TCP829	13.40
1/4"-20	Unified Coarse	3	0.5075"	2-1/2"	H3	TCP830	13.40
1/4"-28	Unified Fine	2	0.5075"	2-1/2"	H3	TCP871	13.40
1/4"-28	Unified Fine	3	0.5075"	2-1/2"	H3	TCP872	13.40
5/16"-18	Unified Coarse	2	0.5939"	2-23/32"	H3	TCP831	14.60
5/16"-18	Unified Coarse	3	0.5939"	2-23/32"	H3	TCP832	14.60
5/16"-24	Unified Fine	2	0.5939"	2-23/32"	H3	TCP873	14.60
5/16"-24	Unified Fine	3	0.5939"	2-23/32"	H3	TCP874	14.60
3/8"-16	Unified Coarse	2	0.602"	2-15/16"	H3	TCP833	17.30
3/8"-16	Unified Coarse	3	0.602"	2-15/16"	H3	TCP834	17.30
3/8"-24	Unified Fine	3	0.602"	2-15/16"	H3	TCP875	17.30

Thread Size	Thread Form	No. of Flutes	L2	L1	Limits	Model No.	Price /Each
3/8"-24	Unified Fine	2	0.602"	2-15/16"	H3	TCP876	17.30
7/16"-14	Unified Coarse	3	0.9055"	3-5/32"	H3	TCP835	29.10
7/16"-20	Unified Fine	3	0.9055"	3-5/32"	H3	TCP877	29.10
1/2"-13	Unified Coarse	3	0.9055"	3-3/8"	H3	TCP836	29.80
1/2"-13	Unified Coarse	3	0.9055"	3-3/8"	H3	TCP837	29.80
1/2"-20	Unified Fine	3	0.9055"	3-3/8"	H3	TCP878	34.20
1/2"-20	Unified Fine	3	0.9055"	3-3/8"	H3	TCP879	34.20
9/16"-12	Unified Coarse	3	0.9843"	3-19/32"	H3	TCP838	58.40
9/16"-18	Unified Fine	3	0.9843"	3-19/32"	H3	TCP880	58.40
5/8"-11	Unified Coarse	3	0.9843"	3-13/16"	H3	TCP839	66.00
5/8"-18	Unified Fine	3	0.9843"	3-13/16"	H3	TCP881	70.30
3/4"-10	Unified Coarse	3	1.1614"	4-1/4"	H4	TCP840	93.90
3/4"-16	Unified Fine	3	1.1614"	4-1/4"	H3	TCP882	98.20
7/8"-9	Unified Coarse	2	1.1614"	4-11/16"	H4	TCP841	129.00
7/8"-14	Unified Fine	3	1.1614"	4-11/16"	H4	TCP883	129.00
1"-8	Unified Coarse	2	1.3976"	5-1/8"	H4	TCP842	159.00
1"-14	Unified Fine	2	1.3976"	5-1/8"	H4	TCP884	164.00

EO26 & EO36 SERIES - STEAM OXIDE FINISH

- Premium substrate with steam oxide surface treatment reduces wear and prevents chip welding in abrasive or harder ferrous materials

Note: Reinforced Shanks: Sizes 2-56 to 3/8"-24
Reduced Shanks: Sizes 7/16"-14 to 1"-14

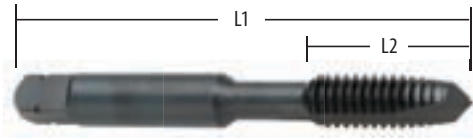

Thread Size	Thread Form	No. of Flutes	L2	L1	Limits	Model No.	Price /Each
2-56	Unified Coarse	2	0.314"	1-3/4"	H2	TCP843	26.30
4-40	Unified Coarse	2	0.6091"	1-7/8"	H2	TCP844	16.40
5-40	Unified Coarse	2	0.7404"	1-15/16"	H2	TCP845	16.40
6-32	Unified Coarse	2	0.261"	2"	H2	TCP846	13.40
8-32	Unified Coarse	2	0.2484"	2-1/8"	H2	TCP847	13.40
10-24	Unified Coarse	2	0.4303"	2-3/8"	H3	TCP848	13.40
10-32	Unified Fine	2	0.4303"	2-3/8"	H2	TCP885	13.40
12-24	Unified Coarse	3	0.4173"	2-3/8"	H3	TCP849	15.10
12-28	Unified Fine	2	0.4173"	2-3/8"	H3	TCP886	14.50
1/4"-20	Unified Coarse	3	0.5075"	2-1/2"	H3	TCP850	13.40
1/4"-20	Unified Coarse	2	0.5075"	2-1/2"	H11	TCP851*	13.40
1/4"-20	Unified Coarse	3	0.5075"	2-1/2"	H3	TCP852	13.40
1/4"-28	Unified Fine	2	0.5075"	2-1/2"	H3	TCP887	13.40
1/4"-28	Unified Fine	3	0.5075"	2-1/2"	H3	TCP888	13.40
5/16"-18	Unified Coarse	3	0.5939"	2-23/32"	H3	TCP853	14.60
5/16"-18	Unified Coarse	2	0.5939"	2-23/32"	H11	TCP854*	14.60
5/16"-18	Unified Coarse	3	0.5939"	2-23/32"	H3	TCP855	14.60
5/16"-24	Unified Fine	2	0.5939"	2-23/32"	H3	TCP889	14.00
5/16"-24	Unified Fine	3	0.5939"	2-23/32"	H3	TCP890	14.00
3/8"-16	Unified Coarse	3	0.602"	2-15/16"	H3	TCP856	17.30
3/8"-16	Unified Coarse	3	0.602"	2-15/16"	H11	TCP857*	17.30

* Tolerance: Oversize +0.005", not 3B

Thread Size	Thread Form	No. of Flutes	L2	L1	Limits	Model No.	Price /Each
3/8"-16	Unified Coarse	2	0.602"	2-15/16"	H3	TCP858	17.30
3/8"-24	Unified Fine	2	0.602"	2-15/16"	H3	TCP891	17.30
7/16"-14	Unified Coarse	3	0.9055"	3-5/32"	H3	TCP859	29.10
7/16"-20	Unified Fine	3	0.9055"	3-5/32"	H3	TCP892	29.10
1/2"-13	Unified Coarse	3	0.9055"	3-3/8"	H3	TCP860	29.80
1/2"-13	Unified Coarse	3	0.9055"	3-3/8"	H11	TCP861*	29.80
1/2"-13	Unified Coarse	3	0.9055"	3-3/8"	H3	TCP862	29.80
1/2"-20	Unified Fine	3	0.9055"	3-3/8"	H3	TCP893	34.20
1/2"-20	Unified Fine	2	0.9055"	3-3/8"	H3	TCP894	34.20
9/16"-12	Unified Coarse	3	0.9843"	3-19/32"	H3	TCP863	58.40
9/16"-18	Unified Fine	3	0.9843"	3-19/32"	H3	TCP895	58.40
5/8"-11	Unified Coarse	3	0.9843"	3-13/16"	H11	TCP864*	66.00
5/8"-11	Unified Coarse	3	0.9843"	3-13/16"	H3	TCP865	66.00
5/8"-18	Unified Fine	3	0.9843"	3-13/16"	H3	TCP896	70.30
3/4"-10	Unified Coarse	2	1.1614"	4-1/4"	H4	TCP866	93.90
3/4"-16	Unified Fine	3	1.1614"	4-1/4"	H3	TCP897	98.20
7/8"-9	Unified Coarse	2	1.1614"	4-11/16"	H4	TCP867	129.00
7/8"-14	Unified Fine	3	1.1614"	4-11/16"	H4	TCP898	129.00
1"-12	Unified Fine	3	1.3976"	5-1/8"	H4	TCP899	159.00
1"-14	Unified Fine	3	1.3976"	5-1/8"	H4	TCP900	164.00



SPIRAL FLUTE TAPS 45°

- Material: High Speed Cobalt
- Manufacturing Standards: ANSI
- Chamfer Type: Semi-Bottoming
- Tolerance: 3B
- Cutting Direction: Right Hand

EO27 & EO37 SERIES - BRIGHT FLUTES & BRONZE OXIDE BODY FINISH

- Premium substrate for blind hole tapping in tough or abrasive materials
- Bronze oxide body and shank reduces rust and corrosion
- Bright finish flutes improve chip flow in soft and non-ferrous materials

Thread Size	Thread Form	No. of Flutes	L2	L1	Limits	Model No.	Price /Each
6-32	Unified Coarse	3	0.261"	2"	H2	TCQ017	25.20
8-32	Unified Coarse	3	0.2484"	2-1/8"	H2	TCQ018	25.20
10-24	Unified Coarse	3	0.265"	2-3/8"	H3	TCQ019	25.20
10-32	Unified Fine	3	0.265"	2-3/8"	H2	TCQ047	25.20
12-24	Unified Coarse	3	0.252"	2-3/8"	H3	TCQ020	27.40
1/4"-20	Unified Coarse	3	0.3937"	2-1/2"	H3	TCQ021	28.70
1/4"-28	Unified Fine	3	0.3937"	2-1/2"	H3	TCQ048	28.70
5/16"-18	Unified Coarse	3	0.4567"	2-23/32"	H3	TCQ022	35.40
5/16"-24	Unified Fine	3	0.4567"	2-23/32"	H3	TCQ049	35.40
3/8"-16	Unified Coarse	3	0.5315"	2-15/16"	H3	TCQ023	40.90
3/8"-24	Unified Fine	3	0.5315"	2-15/16"	H3	TCQ050	40.90
7/16"-14	Unified Coarse	3	0.6299"	3-5/32"	H3	TCQ024	60.70
7/16"-20	Unified Fine	3	0.6299"	3-5/32"	H3	TCQ051	60.70

EO28 & EO38 SERIES - STEAM OXIDE FINISH

- Premium substrate with steam oxide surface treatment reduces wear and prevents chip welding in abrasive or harder ferrous materials

Note: Reinforced shanks: Sizes 4-40 to 3/8"-24
Reduced shanks: Sizes 7/16"-14 to 1"-14

Thread Size	Thread Form	No. of Flutes	L2	L1	Limits	Model No.	Price /Each
4-40	Unified Coarse	3	0.6091"	1-7/8"	H2	TCQ031	26.90
5-40	Unified Coarse	3	0.7404"	1-15/16"	H2	TCQ032	26.90
6-32	Unified Coarse	3	0.261"	2"	H2	TCQ033	25.20
8-32	Unified Coarse	3	0.2484"	2-1/8"	H2	TCQ034	25.20
10-24	Unified Coarse	3	0.265"	2-3/8"	H3	TCQ035	25.20
10-32	Unified Fine	3	0.265"	2-3/8"	H2	TCQ058	25.20
12-24	Unified Coarse	3	0.252"	2-3/8"	H3	TCQ036	27.40
1/4"-20	Unified Coarse	3	0.3937"	2-1/2"	H3	TCQ037	28.70
1/4"-28	Unified Fine	3	0.3937"	2-1/2"	H3	TCQ059	28.70
5/16"-18	Unified Coarse	3	0.4567"	2-23/32"	H3	TCQ038	35.40
5/16"-24	Unified Fine	3	0.4567"	2-23/32"	H3	TCQ060	35.40
3/8"-16	Unified Coarse	3	0.5315"	2-15/16"	H3	TCQ039	40.90
3/8"-24	Unified Fine	3	0.5315"	2-15/16"	H3	TCQ061	40.90
7/16"-14	Unified Coarse	3	0.6299"	3-5/32"	H3	TCQ040	60.70

SPIRAL FLUTE TAP 45°

- Material: High Speed Cobalt
- Manufacturing Standards: ISO 529
- Helix Angle: 45°
- Cutting Direction: Right Hand
- Chamfer Type: Semi-Bottoming
- Tolerance: 6H

Note: ISO shank and square dimensions require metric holders

EO02 SERIES - BRIGHT FLUTE & BRONZE OXIDE BODY FINISH

- Premium substrate for blind hole tapping in tough or abrasive materials
- Bronze oxide body and shank reduces rust and corrosion
- Bright finish flutes improve chip flow in soft and non-ferrous materials

Note: Reinforced shanks: Sizes M2x0.4 to M10x1.5
Reduced shanks: Sizes M12x1.75 to M24x3

Thread Size	Thread Form	No. of Flutes	L2	L1	Limits	Model No.	Price /Each
M2x0.4	Metric Coarse	2	8 mm	41 mm	D3	TCP968	48.00
M2.5x0.45	Metric Coarse	2	9.5 mm	44.5 mm	D3	TCP969	32.40
M3x0.5	Metric Coarse	3	6 mm	48 mm	D3	TCP970	21.50
M4x0.7	Metric Coarse	3	7 mm	53 mm	D4	TCP971	19.00
M5x0.8	Metric Coarse	3	8 mm	58 mm	D4	TCP972	21.10
M6x1	Metric Coarse	3	10 mm	66 mm	D5	TCP973	21.40
M8x1.25	Metric Coarse	3	12 mm	72 mm	D5	TCP974	23.80
M10x1.5	Metric Coarse	3	15 mm	80 mm	D6	TCP975	29.40

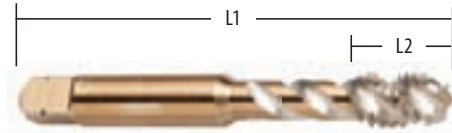

Thread Size	Thread Form	No. of Flutes	L2	L1	Limits	Model No.	Price /Each
1/2"-13	Unified Coarse	3	0.689"	3-3/8"	H3	TCQ025	72.80
1/2"-20	Unified Fine	3	0.689"	3-3/8"	H3	TCQ052	72.80
9/16"-12	Unified Coarse	3	0.7087"	3-19/32"	H3	TCQ026	121.00
9/16"-18	Unified Fine	3	0.7087"	3-19/32"	H3	TCQ053	121.00
5/8"-11	Unified Coarse	3	0.7087"	3-13/16"	H3	TCQ027	121.00
5/8"-18	Unified Fine	3	0.7087"	3-13/16"	H3	TCQ054	121.00
3/4"-10	Unified Coarse	3	0.8858"	4-1/4"	H4	TCQ028	165.00
3/4"-16	Unified Fine	3	0.8858"	4-1/4"	H3	TCQ055	165.00
7/8"-9	Unified Coarse	3	0.9843"	4-11/16"	H4	TCQ029	208.00
7/8"-14	Unified Fine	3	0.9843"	4-11/16"	H4	TCQ056	208.00
1"-8	Unified Coarse	3	1.1811"	5-1/8"	H4	TCQ030	274.00
1"-14	Unified Fine	3	1.1811"	5-1/8"	H4	TCQ057	274.00



Thread Size	Thread Form	No. of Flutes	L2	L1	Limits	Model No.	Price /Each
7/16"-20	Unified Fine	3	0.6299"	3-5/32"	H3	TCQ062	60.70
1/2"-13	Unified Coarse	3	0.689"	3-3/8"	H3	TCQ041	72.80
1/2"-20	Unified Fine	3	0.689"	3-3/8"	H3	TCQ063	72.80
9/16"-12	Unified Coarse	3	0.7087"	3-19/32"	H3	TCQ042	121.00
9/16"-18	Unified Fine	3	0.7087"	3-19/32"	H3	TCQ064	121.00
5/8"-11	Unified Coarse	3	0.7087"	3-13/16"	H3	TCQ043	121.00
5/8"-18	Unified Fine	3	0.7087"	3-13/16"	H3	TCQ065	121.00
3/4"-10	Unified Coarse	3	0.8858"	4-1/4"	H4	TCQ044	165.00
3/4"-16	Unified Fine	3	0.8858"	4-1/4"	H3	TCQ066	165.00
7/8"-9	Unified Coarse	3	0.9843"	4-11/16"	H4	TCQ045	208.00
7/8"-14	Unified Fine	3	0.9843"	4-11/16"	H4	TCQ067	208.00
1"-8	Unified Coarse	3	1.1811"	5-1/8"	H4	TCQ046	274.00
1"-14	Unified Fine	3	1.1811"	5-1/8"	H4	TCQ068	274.00

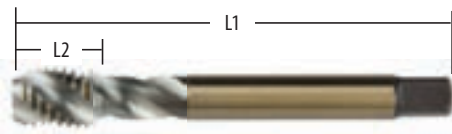

Thread Size	Thread Form	No. of Flutes	L2	L1	Limits	Model No.	Price /Each
M12x1.75	Metric Coarse	3	16 mm	89 mm	D6	TCP976	42.20
M14x2	Metric Coarse	3	18 mm	95 mm	D7	TCP977	65.40
M16x2	Metric Coarse	4	18 mm	102 mm	D7	TCP978	64.80
M18x2.5	Metric Coarse	4	29 mm	112 mm	D7	TCP979	104.00
M20x2.5	Metric Coarse	4	29 mm	112 mm	D7	TCP980	114.00
M22x2.5	Metric Coarse	4	29 mm	118 mm	D8	TCP981	134.00
M24x3	Metric Coarse	4	35 mm	130 mm	D8	TCP982	155.00

CUTTING TOOLS

SPIRAL FLUTE TAP 45° (CONT.)

E003 & EO13 SERIES - STEAM OXIDE FINISH

- Premium substrate with steam oxide surface treatment reduces wear and prevents chip welding in abrasive or harder ferrous materials

Note: Reinforced shanks: sizes M2x0.4 to M10X1.25
Reduced shanks: sizes M12X1 to M24x3

Thread Size	Thread Form	No. of Flutes	L2	L1	Limits	Model No.	Price /Each
M2x0.4	Metric Coarse	2	8 mm	41 mm	D3	TCP983	48.00
M2.5x0.45	Metric Coarse	2	9.5 mm	44.5 mm	D3	TCP984	32.40
M3x0.5	Metric Coarse	3	6 mm	48 mm	D3	TCP985	21.50
M4X0.5	Metric Fine	3	7 mm	53 mm	D4	TCP998	44.60
M4x0.7	Metric Coarse	3	7 mm	53 mm	D4	TCP986	19.00
M5X0.5	Metric Fine	3	8 mm	58 mm	D4	TCP999	39.30
M5x0.8	Metric Coarse	3	8 mm	58 mm	D4	TCP987	21.10
M6X0.5	Metric Fine	3	10 mm	66 mm	D5	TQ000	49.10
M6X0.75	Metric Fine	3	10 mm	66 mm	D5	TQ001	49.10
M6x1	Metric Coarse	3	10 mm	66 mm	D5	TCP988	21.40
M8X0.75	Metric Fine	3	12 mm	72 mm	D5	TQ002	57.00
M8X1	Metric Fine	3	12 mm	72 mm	D5	TQ003	57.00
M8x1.25	Metric Coarse	3	12 mm	72 mm	D5	TCP989	23.80
M10X1	Metric Fine	3	15 mm	80 mm	D6	TQ004	66.90
M10X1.25	Metric Fine	3	15 mm	80 mm	D6	TQ005	66.90
M10x1.5	Metric Coarse	3	15 mm	80 mm	D6	TCP990	29.40

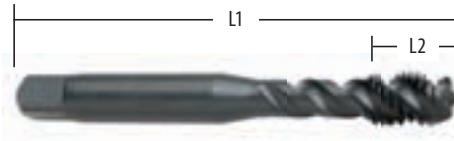

Thread Size	Thread Form	No. of Flutes	L2	L1	Limits	Model No.	Price /Each
M12X1	Metric Fine	3	16 mm	89 mm	D6	TCQ006	90.90
M12X1.25	Metric Fine	3	16 mm	89 mm	D6	TCQ007	90.90
M12X1.5	Metric Fine	3	16 mm	89 mm	D6	TCQ008	90.90
M12x1.75	Metric Coarse	3	16 mm	89 mm	D6	TCP991	42.20
M14X1.5	Metric Fine	3	18 mm	95 mm	D7	TCQ009	120.00
M14x2	Metric Coarse	3	18 mm	95 mm	D7	TCP992	65.40
M16X1	Metric Fine	4	18 mm	102 mm	D7	TCQ010	138.00
M16X1.5	Metric Fine	4	18 mm	102 mm	D7	TCQ011	138.00
M16x2	Metric Coarse	4	18 mm	102 mm	D7	TCP993	64.80
M18X1.5	Metric Fine	4	29 mm	112 mm	D7	TCQ012	199.00
M18x2.5	Metric Coarse	4	29 mm	112 mm	D7	TCP994	104.00
M20X1.5	Metric Fine	4	29 mm	112 mm	D7	TCQ013	218.00
M20x2.5	Metric Coarse	4	29 mm	112 mm	D7	TCP995	114.00
M22X1.5	Metric Fine	4	29 mm	112 mm	D8	TCQ014	256.00
M22x2.5	Metric Coarse	4	29 mm	118 mm	D8	TCP996	134.00
M24x3	Metric Coarse	4	35 mm	130 mm	D8	TCP997	155.00

MEDIUM HOOK PIPE TAPS

E710 SERIES

- Generally used for pipe fittings and couplings in most ferrous and non-ferrous materials
- Medium hook for multi-material tapping
- Straight flute
- Material: High Speed Steel
- Thread Form: National Taper Pipe
- Manufacturing Standards: ANSI B94.9
- Finish: Bright
- Cutting Direction: Right Hand

Note: NPT threads require the use of a sealant such as teflon tape or pipe compound to ensure a tight joint

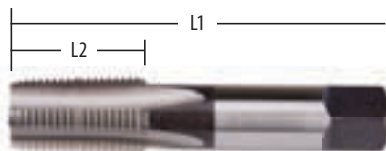

Pipe Size	No. of Flutes	L2	L1	Model No.	Price /Each
1/16"-27	4	17 mm	65 mm	TCP958	36.90
1/8"-27	4	19 mm	70 mm	TCP959	36.90
1/4"-18	4	27 mm	75 mm	TCP960	40.00
3/8"-18	4	27 mm	80 mm	TCP961	52.70
1/2"-14	4	35 mm	100 mm	TCP962	82.90
3/4"-14	5	35 mm	105 mm	TCP963	119.00
1"-11.5	5	43 mm	115 mm	TCP964	178.00
1-1/4"-11.5	5	43 mm	125 mm	TCP965	253.00
1-1/2"-11.5	7	43 mm	135 mm	TCP966	347.00
2"-11.5	7	43 mm	145 mm	TCP967	466.00

SCREW EXTRACTORS

- Left hand rotation screw extractors
- Material: Chromium Steel



1800 SERIES

Extractor Size	For Screw/Bolt Sizes	For Pipe Sizes	Overall Length	Small End Diameter	Shank Size	Model No.	Price /Each
#1	3/16" - 1/4"	-	2"	0.054"	5/32"	TCP901	7.17
#2	1/4" - 5/16"	-	2-3/8"	0.086"	3/16"	TCP902	7.55
#3	5/16" - 7/16"	-	2-3/4"	1/8"	1/4"	TCP903	9.29
#4	7/16" - 9/16"	-	3"	11/64"	5/16"	TCP904	9.69
#5	9/16" - 3/4"	1/8" - 1/4"	3-3/8"	1/4"	7/16"	TCP905	12.50
#6	3/4" - 1"	3/8"	3-3/4"	3/8"	5/8"	TCP906	26.70
#7	1" - 1-3/8"	1/2"	4-1/8"	31/64"	3/4"	TCP907	43.40
#8	1-3/8" - 1-3/4"	3/4"	4-3/8"	47/64"	1"	TCP908	58.70
#9	1-3/4" - 2-1/8"	1"	4-5/8"	31/32"	1-1/4"	TCP909	101.00
#10	2-1/8" - 2-1/2"	1-1/4"	5"	1-7/32"	1-17/32"	TCP910	142.00
#11	2-1/2" - 3"	1-1/2"	5-5/8"	1-15/32"	1-27/32"	TCP911	210.00
#12	3" - 3-1/2"	2"	6-1/4"	1-27/32"	2-9/32"	TCP912	339.00

1815 & 1816 SERIES

Extractor Size	For Screw/Bolt Sizes	For Pipe Sizes	Model No.	Price /Each
#1 to #5	3/16" - 3/4"	1/8" - 1/4"	TCP913	56.00
#1 to #6	3/16" - 1"	1/8" - 3/8"	TCP914	83.50

STRAIGHT HANDLE TAP WRENCHES

3850 SERIES

- Ideal for hand tapping
- Hardened steel jaws are opened and closed by simply twisting one hand which is knurled for side gripping



UNION BUTTERFIELD®

Imperial Hand Tap Capacity	Metric Hand Tap Capacity	Hand Reamer Capacity	Size	Model No.	Price /Each
1/16" - 5/16"	M1 - M8	1/8" - 5/16"	#8	TCP921	202.00
3/16" - 1/2"	M4 - M12	3/16" - 3/8"	#9	TCP922	247.00
1/4" - 3/4"	M3 - M18	1/4" - 9/16"	#10	TCP923	294.00
3/8" - 1"	M10 - M25	3/8" - 3/4"	#11	TCP924	390.00
3/8" - 1-1/8"	M10 - M27	3/8" - 7/8"	#12	TCP925	458.00
7/8" - 1-7/8"	M22 - M42	5/8" - 1-1/2"	#14	TCP926	685.00

UNION BUTTERFIELD®

COMBINED DRILLS & COUNTERSINKS 60°

76HA SERIES

- Bright finish improves chip flow in soft or non-ferrous materials
- 60° countersink
- Material: High Speed Steel
- Manufacturing Standards: ANSI
- Cutting Direction: Right Hand



No. Size	Size	Decimal Size	Body Diameter	Overall Length	Model No.	Price /Each
#000	0.02"	0.02"	1/8"	1-1/4"	TCQ551	25.90
#00	0.025"	0.025"	1/8"	1-1/8"	TCQ552	9.75
#0	1/32"	0.0312"	1/8"	1-1/8"	TCQ553	9.75
#1	3/64"	0.0468"	1/8"	1-1/4"	TCQ554	7.93
#2	5/64"	0.0781"	3/16"	1-7/8"	TCQ555	8.08
#3	7/64"	0.1093"	1/4"	2"	TCQ556	8.55
#4	1/8"	0.125"	5/16"	2-1/8"	TCQ557	8.66
#5	3/16"	0.1875"	7/16"	2-3/4"	TCQ558	14.10
#6	7/32"	0.2187"	1/2"	3"	TCQ559	22.30
#7	1/4"	0.25"	5/8"	3-1/4"	TCQ560	30.30
#8	5/16"	0.3125"	3/4"	3-1/2"	TCQ561	42.30

COMBINED DRILLS & COUNTERSINKS 82°

A217 SERIES

- Bright finish improves chip flow in soft or non-ferrous materials
- 82° countersink
- Material: High Speed Steel
- Manufacturing Standards: ANSI
- Cutting Direction: Right Hand



No. Size	Size	Decimal Size	Body Diameter	Overall Length	Model No.	Price /Each
#1	3/64"	0.0469"	1/8"	1-1/4"	TCQ617	9.20
#2	5/64"	0.0781"	3/16"	1-7/8"	TCQ618	9.39
#3	7/64"	0.1094"	1/4"	2"	TCQ619	9.93
#4	1/8"	0.125"	5/16"	2-1/8"	TCQ620	10.10
#5	3/16"	0.1875"	7/16"	2-3/4"	TCQ621	16.30
#6	7/32"	0.2188"	1/2"	3"	TCQ622	26.20
#7	1/4"	0.25"	5/8"	3-1/4"	TCQ623	35.80
#8	5/16"	0.3125"	3/4"	3-1/2"	TCQ624	49.80

COMBINED DRILL & COUNTERSINK 60°

A225 SERIES

- Bright finish improves chip flow in soft or non-ferrous materials
- 60° countersink
- Material: High Speed Steel
- Manufacturing Standards: BS 328
- Cutting Direction: Right Hand



No. Size	Size	Decimal Size	Body Diameter	Overall Length	Model No.	Price /Each
BS1	3/64"	0.0469"	1/8"	1-1/2"	TCQ626	6.80
BS2	1/16"	0.0625"	3/16"	1-3/4"	TCQ627	7.49
BS3	3/32"	0.0938"	1/4"	2"	TCQ628	9.31
BS4	1/8"	0.125"	5/16"	2-1/4"	TCQ629	12.00
BS5	3/16"	0.1875"	7/16"	2-1/2"	TCQ630	17.40
BS5A	7/32"	0.2188"	1/2"	2-3/4"	TCQ631	31.10
BS6	1/4"	0.25"	5/8"	3"	TCQ632	52.80
BS7	5/16"	0.3125"	3/4"	3-1/2"	TCQ633	76.40

COMBINED DRILL & COUNTERSINK SETS

A217SET SERIES

- Bright finish improves chip flow in soft or non-ferrous materials
- 82° countersink
- 5-Piece set
- Material: High Speed Steel
- Manufacturing Standards: ANSI
- Cutting Direction: Right Hand



Wire Gauge	Size	Model No.	Price /Each
#1 to #5	3/64" to 3/16"	TCQ625	78.60

**Afraid of Heights...
We've Got You Covered!**



**Canada's Leading
Material Handling Supplier**



CUTTING TOOLS

3-FLUTE STRAIGHT SHANK COUNTERSINKS

G154 SERIES

- Bright finish improves chip flow in soft ferrous or non-ferrous materials
- Material: High Speed Steel
- Countersink Angle: 82°
- Number Of Flutes: 3
- Manufacturing Standards: DIN 335C
- Cutting Direction: Right Hand

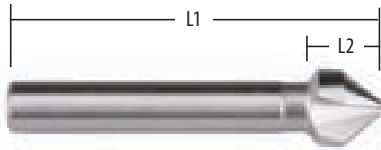

DORMER

Head Dia.	L2	L1	Shank Dia.	Min. Head Dia.	Model No.	Price /Each
6.3 mm	5.5 mm	45 mm	5 mm	1.5 mm	TCP951	24.00
8.3 mm	6.5 mm	50 mm	6 mm	2 mm	TCP952	24.10
10.4 mm	7.6 mm	50 mm	6 mm	2.5 mm	TCP953	27.00
12.4 mm	8.5 mm	56 mm	8 mm	2.8 mm	TCP954	39.60
16.5 mm	10.5 mm	60 mm	10 mm	3.2 mm	TCP955	53.40
20.5 mm	13 mm	63 mm	10 mm	3.5 mm	TCP956	71.30
25 mm	15.5 mm	67 mm	10 mm	3.8 mm	TCP957	129.00

3-FLUTE STRAIGHT SHANK COUNTERSINKS

4608 SERIES

- Widely used to countersink screw and rivet heads and to countersink holes for lathe centers
- The odd number of flutes eliminates chatter in most applications while providing better accuracy than a single-flute countersink
- Material: High Speed Steel
- Manufacturing Standards: ANSI
- Finish: Bright
- Cutting Direction: Right Hand
- No. of Flutes: 3

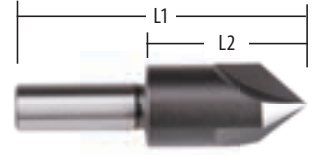

UNION BUTTERFIELD®

Head Dia.	Countersink Angle	L2	L1	Model No.	Price /Each
1/4"	60°	3/4"	1-1/2"	TCP927	17.30
1/4"	82°	3/4"	1-1/2"	TCP932	17.30
1/4"	90°	3/4"	1-1/2"	TCP937	17.30
1/4"	100°	3/4"	1-1/2"	TCP942	17.30
3/8"	60°	7/8"	1-3/4"	TCP928	20.40
3/8"	82°	7/8"	1-3/4"	TCP933	20.40
3/8"	90°	7/8"	1-3/4"	TCP938	20.40
3/8"	100°	7/8"	1-3/4"	TCP943	20.40
1/2"	60°	1"	2"	TCP929	26.40
1/2"	82°	1"	2"	TCP934	26.40
1/2"	90°	1"	2"	TCP939	26.40
1/2"	100°	1"	2"	TCP944	26.40
5/8"	60°	1"	2-1/4"	TCP930	38.10
5/8"	82°	1"	2-1/4"	TCP935	38.10
5/8"	90°	1"	2-1/4"	TCP940	38.10
5/8"	100°	1"	2-1/4"	TCP945	38.10
3/4"	60°	1-1/4"	2-5/8"	TCP931	50.40
3/4"	82°	1-1/4"	2-5/8"	TCP936	50.40
3/4"	90°	1-1/4"	2-5/8"	TCP941	50.40
3/4"	100°	1-1/4"	2-5/8"	TCP946	50.40
1"	60°	1"	3"	TCP947	94.90
1"	82°	1"	3"	TCP948	94.90
1"	90°	1"	3"	TCP949	94.90
1"	100°	1"	3"	TCP950	94.90

Can't find what you're looking for?



Call us today!

EYEWEAR
 SPILL CONTROL
 TRAFFIC CONTROL
SAFETY
 GLOVES

ZENITH®
 Safety Products

JOBBER LENGTH" HIGH SPEED STEEL SETS



WJ188

BLACK & GOLD MULTI APPLICATION

- Industrial duty
- Right hand 135° split point eliminates walking
- General purpose used on steels, cast iron and most non-ferrous metals
- Machine and portable drilling applications
- Two-tone black oxide and bronze finish provides ideal chip flow and resistance to abrasion
- Steel case

FRACTIONAL SETS

Model No.	Description	Sizes	Price/Each
QR040	13-piece set	1/16" to 1/4" by 64ths	39.50
BG060	15-piece set	1/16" to 1/2" by 32nds	115.00
BG063	21-piece set	1/16 to 3/8" by 64ths	102.00
WJ188	29-piece set	1/16" to 1/2" by 64ths	197.00

METRIC SETS

Model No.	Description	Sizes	Price/Each
BG057	13-piece set	1.5 mm to 6.5 mm by 0.5 mm	51.00
BG061	19-piece set	1.0 mm to 10.0 mm by 0.5 mm	99.50
BG064	25-piece set	1.0 mm to 13.0 mm by 0.5 mm	145.00
BG058	50-piece set	1.0 mm to 5.9 mm by 0.1 mm	93.10
BG059	41-piece set	6.0 mm to 10.0 mm by 0.1 mm	252.00

WIRE GAUGE & LETTER SETS

Model No.	Description	Sizes	Price/Each
BG066	60-piece set	#1 to #60	164.00
BG062	20-piece set	#61 to #80	73.50
BG065	26-piece set	Letter A to Z	223.00

CLARKSON OSBORN

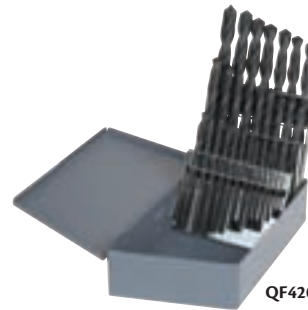

QF420

HYPER

- Maintenance duty
- Right hand, 118° point
- General purpose used on steels, cast iron and most non-ferrous metals
- Machine and portable drilling applications
- Black oxide finish
- Steel case

FRACTIONAL SETS

Model No.	Description	Sizes	Price/Each
BM889	13-piece set	1/16" to 1/4" by 64ths	28.50
BM890	15-piece set	1/16" to 1/2" by 32nds	60.90
BM891	21-piece set	1/16 to 3/8" by 64ths	50.80
QF420	29-piece set	1/16" to 1/2" by 64ths	89.50

WIRE GAUGE & LETTER SETS

Model No.	Description	Sizes	Price/Each
BM897	60-piece set	#1 to #60	87.50
BM892	26-piece set	Letter A to Z	123.00

JOBBER LENGTH" – COBALT

- M42 cobalt provides wear and heat resistance
- Straight shank, 2 flute design
- Right hand cutting direction
- 135° split point, self-centring eliminates walking
- Bright finish

Applications

For general purpose drilling to heavy-duty operations in high tensile strength steel and alloys, stainless steels and other ferrous metals

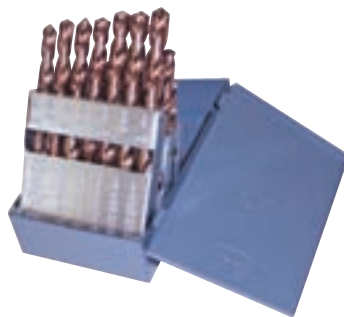

CLARKSON OSBORN

FRACTIONAL SETS

Model No.	Description	Sizes	Price/Each
BG067	15-piece set	1/16" to 1/2" by 32nds	195.00
BG069	21-piece set	1/16" to 3/8" by 64ths	183.00
BG071	29-piece set	1/16" to 1/2" by 64ths	374.00

METRIC SETS

Model No.	Description	Sizes	Price/Each
BG068	19-piece set	1.0 mm to 10.0 mm by 0.5 mm	254.00
BG070	25-piece set	1.0 mm to 13.0 mm by 0.5 mm	559.00

DRILL DOCTOR®



Designed for durability and flexibility required to sharpen the largest range and most popular sizes of dull or broken bits-including split points and masonry bits.

- Sharpens 118° to 135° drill point angles
- For all standard twist drills
- Sharpens high speed steel, cobalt, tin-coated and carbide tipped masonry drills
- Includes diamond sharpening wheel and moulded plastic case
- 110 V power supply

Model No.	Description	Price/Each
TZ961	Sharpens 3/32" to 1/2"	217.00

Model No.	Description	Price/Each
BC896	Sharpens 3/32" to 3/4"	258.00

CUTTING TOOLS

JOBBER LENGTH – HIGH SPEED STEEL

HYPER

- Hyper series - maintenance duty
- Straight shank, 2 flute design
- Right hand cutting direction
- 118° point
- Black oxide finish

Applications:

General purpose machine and hand drilling in a variety of steels, alloys and other non-ferrous materials.

CLARKSON OSBORN



Fractional Size"	Decimal"	L2"	L1"	Model No.	Price /Each
3/64	0.0469	7/8	1 7/8	QR954	1.22
1/16	0.0625	7/8	1 7/8	QR955	0.82
5/64	0.0781	1	2	QR927	0.82
3/32	0.0938	1 1/4	2 1/4	QR925	0.82
7/64	0.1094	1 1/2	2 5/8	QR919	0.82
1/8	0.1250	1 5/8	2 3/4	QR953	0.96
9/64	0.1406	1 3/4	2 7/8	QR920	1.06
5/32	0.1562	2	3 1/8	QR921	1.16
11/64	0.1719	2 1/8	3 1/4	QR922	1.30
3/16	0.1875	2 5/16	3 1/2	QR923	1.50
13/64	0.2031	2 7/16	3 5/8	QR924	1.62
7/32	0.2188	2 1/2	3 3/4	QR936	1.92
15/64	0.2344	2 5/8	3 7/8	QR926	2.06
1/4	0.2500	2 3/4	4	QR917	2.18
17/64	0.2656	2 7/8	4 1/8	QR928	2.68

Letter Size	Decimal"	L2"	L1"	Model No.	Price /Each
A	0.2340	2 5/8	3 7/8	BM802	2.34
B	0.2380	2 3/4	4	BM803	2.34
C	0.2420	2 3/4	4	BM804	2.34
D	0.2460	2 3/4	4	BM805	2.34
E	0.2500	2 3/4	4	BM806	2.34
F	0.2570	2 7/8	4 1/8	BM807	3.14
G	0.2610	2 7/8	4 1/8	BM808	3.14
H	0.2660	2 7/8	4 1/8	BM809	3.14
I	0.2720	2 7/8	4 1/8	BM810	3.14
J	0.2770	2 7/8	4 1/8	BM811	3.14
K	0.2810	2 15/16	4 1/4	BM812	3.42
L	0.2900	2 15/16	4 1/4	BM813	3.42
M	0.2950	3 1/16	4 3/8	BM814	3.84

Wire Ga. Size	Decimal"	L2"	L1"	Model No.	Price /Each
60	0.0400	11/16	1 5/8	BM887	1.22
59	0.0410	11/16	1 5/8	BM886	1.22
58	0.0420	11/16	1 5/8	BM885	1.22
57	0.0430	3/4	1 3/4	BM884	1.22
56	0.0465	3/4	1 3/4	BM883	1.22
55	0.0520	7/8	1 7/8	BM882	0.82
54	0.0550	7/8	1 7/8	BM881	0.82
53	0.0595	7/8	1 7/8	BM880	0.82
52	0.0635	7/8	1 7/8	BM879	0.82
51	0.0670	1	2	BM878	0.82
50	0.0700	1	2	BM877	0.82
49	0.0730	1	2	BM876	0.82
48	0.0760	1	2	BM875	0.82
47	0.0785	1	2	BM874	0.82
46	0.0810	1 1/8	2 1/8	BM873	0.82
45	0.0820	1 1/8	2 1/8	BM872	0.82
44	0.0860	1 1/8	2 1/8	BM871	0.82
43	0.0890	1 1/4	2 1/4	BM870	0.82
42	0.0935	1 1/4	2 1/4	BM869	0.82
41	0.0960	1 3/8	2 3/8	BM868	0.82
40	0.0980	1 3/8	2 3/8	BM867	0.94
39	0.0995	1 3/8	2 3/8	BM866	0.94
38	0.1015	1 7/16	2 1/2	BM865	0.94
37	0.1040	1 7/16	2 1/2	BM864	0.94
36	0.1065	1 7/16	2 1/2	BM863	0.94
35	0.1100	1 1/2	2 5/8	BM862	1.22
34	0.1110	1 1/2	2 5/8	BM861	1.22
33	0.1130	1 1/2	2 5/8	BM860	1.22
32	0.1160	1 5/8	2 3/4	BM859	1.22
31	0.1200	1 5/8	2 3/4	BM858	1.22

Fractional Size"	Decimal"	L2"	L1"	Model No.	Price /Each
9/32	0.2812	2 15/16	4 1/4	QR929	2.86
19/64	0.2969	3 1/16	4 3/8	QR930	3.28
5/16	0.3125	3 3/16	4 1/2	QR948	3.44
21/64	0.3281	3 5/16	4 5/8	QR083	3.84
11/32	0.3438	3 7/16	4 3/4	QR082	4.32
23/64	0.3594	3 1/2	4 7/8	QR071	5.16
3/8	0.3750	3 5/8	5	QR080	5.16
25/64	0.3906	3 3/4	5 1/8	QR090	5.76
13/32	0.4062	3 7/8	5 1/4	QR078	6.74
27/64	0.4219	3 15/16	5 3/8	QR077	6.92
7/16	0.4375	4 1/16	5 1/2	QR076	8.24
29/64	0.4531	4 3/16	5 5/8	QR104	8.40
15/32	0.4688	4 5/16	5 3/4	QR074	9.02
31/64	0.4844	4 3/8	5 7/8	QR084	9.78
1/2	0.5000	4 1/2	6	QR099	10.00

Letter Size	Decimal"	L2"	L1"	Model No.	Price /Each
N	0.3020	3 1/16	4 3/8	BM815	3.84
O	0.3160	3 3/16	4 1/2	BM816	4.18
P	0.3230	3 5/16	4 5/8	BM817	4.48
Q	0.3320	3 7/16	4 3/4	BM818	5.10
R	0.3390	3 7/16	4 3/4	BM819	5.10
S	0.3480	3 1/2	4 7/8	BM820	6.26
T	0.3580	3 1/2	4 7/8	BM821	6.26
U	0.3680	3 5/8	5	BM822	6.26
V	0.3770	3 5/8	5	BM823	6.26
W	0.3860	3 3/4	5 1/8	BM824	7.04
X	0.3970	3 3/4	5 1/8	BM825	7.04
Y	0.4040	3 7/8	5 1/4	BM826	7.04
Z	0.4130	3 7/8	5 1/4	BM827	7.04

Wire Ga. Size	Decimal"	L2"	L1"	Model No.	Price /Each
30	0.1285	1 5/8	2 3/4	BM857	1.22
29	0.1360	1 3/4	2 7/8	BM856	1.22
28	0.1405	1 3/4	2 7/8	BM855	1.22
27	0.1440	1 7/8	3	BM854	1.34
26	0.1470	1 7/8	3	BM853	1.34
25	0.1495	1 7/8	3	BM852	1.34
24	0.1520	2	3 1/8	BM851	1.34
23	0.1540	2	3 1/8	BM850	1.34
22	0.1570	2	3 1/8	BM849	1.34
21	0.1590	2 1/8	3 1/4	BM848	1.50
20	0.1610	2 1/8	3 1/4	BM847	1.50
19	0.1660	2 1/8	3 1/4	BM846	1.50
18	0.1695	2 1/8	3 1/4	BM845	1.50
17	0.1730	2 3/16	3 3/8	BM844	1.72
16	0.1770	2 3/16	3 3/8	BM843	1.72
15	0.1800	2 3/16	3 3/8	BM842	1.72
14	0.1820	2 3/16	3 3/8	BM841	1.72
13	0.1850	2 5/16	3 1/2	BM840	1.72
12	0.1890	2 5/16	3 1/2	BM839	1.92
11	0.1910	2 5/16	3 1/2	BM838	1.92
10	0.1935	2 7/16	3 5/8	BM837	1.92
9	0.1960	2 7/16	3 5/8	BM836	1.92
8	0.1990	2 7/16	3 5/8	BM835	1.92
7	0.2010	2 7/16	3 5/8	BM834	1.92
6	0.2040	2 1/2	3 3/4	BM833	2.12
5	0.2055	2 1/2	3 3/4	BM832	2.12
4	0.2090	2 1/2	3 3/4	BM831	2.12
3	0.2130	2 1/2	3 3/4	BM830	2.12
2	0.2210	2 5/8	3 7/8	BM829	2.34
1	0.2280	2 5/8	3 7/8	BM828	2.34

JOBBER LENGTH – HIGH SPEED STEEL

BLACK & GOLD

- Industrial-duty
- Straight shank, 2-flute design
- Right hand cutting direction
- 135° split point, self-centering eliminates walking
- Two-tone treatment increases resistance to abrasion and chip flow

Applications:

General purpose and heavy drilling operations. Ideal for ferrous metals: steel, cast iron, ferrous metals and alloys, non-metallic material.

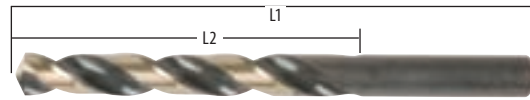

Fractional Sizes"	Decimal"	L2"	L1"	Model No.	Price /Each
1/64	0.0156	3/16	13/16	QD657	2.98
1/32	0.0312	13/32	1 3/16	QD658	1.89
3/64	0.0469	7/8	1 7/8	QD659	1.85
1/16	0.0625	7/8	1 7/8	QD660	1.85
5/64	0.0781	1	2	QD661	1.85
3/32	0.0938	1 1/4	2 1/4	QD662	1.85
7/64	0.1094	1 1/2	2 5/8	QD663	2.04
1/8	0.1250	1 5/8	2 3/4	QD664	2.36
9/64	0.1406	1 3/4	2 7/8	QD665	2.36
5/32	0.1562	2	3 1/8	QD666	2.51
11/64	0.1719	2 1/8	3 1/4	QD667	2.70
3/16	0.1875	2 5/16	3 1/2	QD668	3.02
13/64	0.2031	2 7/16	3 5/8	QD669	3.51
7/32	0.2188	2 1/2	3 3/4	QD670	3.91
15/64	0.2344	2 5/8	3 7/8	QD671	4.11
1/4	0.2500	2 3/4	4	QD672	4.57
17/64	0.2656	2 7/8	4 1/8	QD673	5.34
9/32	0.2812	2 15/16	4 1/4	QD674	5.45
19/64	0.2969	3 1/16	4 3/8	QD675	6.28
5/16	0.3125	2 3/16	4 1/2	QD676	6.89
21/64	0.3281	3 5/16	4 5/8	QD677	7.62
11/32	0.3438	3 7/16	4 3/4	QD678	8.57
23/64	0.3594	3 1/2	4 7/8	QD679	9.53

Wire Ga. Size	Decimal"	L2"	L1"	Model No.	Price /Each
80	0.0135	5/32	3/4	BF675	3.60
79	0.0145	5/32	3/4	BF674	3.60
78	0.0160	3/16	13/16	BF673	3.02
77	0.0180	3/16	13/16	BF672	3.02
76	0.0200	1/4	7/8	BF671	3.02
75	0.0210	9/32	15/16	BF670	3.02
74	0.0225	9/32	15/16	BF669	3.02
73	0.0240	5/16	1	BF668	3.02
72	0.0250	5/16	1	BF667	3.02
71	0.0260	5/16	1	BF666	3.02
70	0.0280	11/32	1 1/8	BF665	2.70
69	0.0292	11/32	1 1/8	BF664	2.70
68	0.0310	13/32	1 3/16	BF663	2.32
67	0.0320	13/32	1 3/16	BF662	2.32
66	0.0330	13/32	1 3/16	BF661	2.32
65	0.0350	7/16	1 1/4	QD721	2.32
64	0.0360	7/16	1 1/4	BF660	2.32
63	0.0370	7/16	1 1/4	BF659	2.32
62	0.0380	15/32	1 5/16	BF658	2.32
61	0.0390	15/32	1 5/16	BF657	2.32
60	0.0400	11/16	1 5/8	BF656	2.32
59	0.0410	11/16	1 5/8	BF655	2.32
58	0.0420	11/16	1 5/8	BF654	2.32
57	0.0430	3/4	1 3/4	BF653	2.32
56	0.0465	3/4	1 3/4	BF652	2.23
55	0.0520	7/8	1 7/8	BF651	2.23
54	0.0550	7/8	1 7/8	BF650	2.23
53	0.0595	7/8	1 7/8	BF649	2.11
52	0.0635	7/8	1 7/8	BF648	2.11
51	0.0670	1	2	QD720	2.11
50	0.0700	1	2	BF647	2.11
49	0.0730	1	2	QD719	2.11
48	0.0760	1	2	BF646	2.11
47	0.0785	1	2	QD718	2.11
46	0.0810	1 1/8	2 1/8	BF645	2.11
45	0.0820	1 1/8	2 1/8	BF644	2.11
44	0.0860	1 1/8	2 1/8	BF643	2.11
43	0.0890	1 1/4	2 1/4	QD717	2.11
42	0.0935	1 1/4	2 1/4	QD716	2.11
41	0.0960	1 3/8	2 3/8	BF642	2.23

Letter Size	Decimal"	L2"	L1"	Model No.	Price /Each
A	0.2340	2 5/8	3 7/8	BF603	4.45
B	0.2380	2 3/4	4	BF604	4.74
C	0.2420	2 3/4	4	BF605	4.74
D	0.2460	2 3/4	4	BF606	4.74
E	0.2500	2 3/4	4	-	-
F	0.2570	2 7/8	4 1/8	BF608	5.40
G	0.2610	2 7/8	4 1/8	BF609	5.74
H	0.2660	2 7/8	4 1/8	BF610	5.74
I	0.2720	2 7/8	4 1/8	BF611	5.74
J	0.2770	2 7/8	4 1/8	BF612	6.00
K	0.2810	2 15/16	4 1/4	BF613	6.28
L	0.2900	2 15/16	4 1/4	BF614	6.77
M	0.2950	3 1/16	4 3/8	BF615	7.15

Fractional Size"	Decimal"	L2"	L1"	Model No.	Price /Each
3/8	0.3750	3 5/8	5	QD680	9.72
25/64	0.3906	3 3/4	5 1/8	QD681	11.10
13/32	0.4062	3 7/8	5 1/4	QD682	11.50
27/64	0.4219	3 15/16	5 3/8	QD683	12.70
7/16	0.4375	4 1/16	5 1/2	QD684	13.20
29/64	0.4531	4 3/16	5 5/8	QD685	15.40
15/32	0.4688	4 5/16	5 3/4	QD686	15.90
31/64	0.4844	4 3/8	5 7/8	QD687	16.70
1/2	0.5000	4 1/2	6	QD688	16.80
33/64	0.5156	4 13/16	6 5/8	BF590	24.50
17/32	0.5313	4 13/16	6 5/8	BF591	23.90
35/64	0.5469	4 13/16	6 5/8	BF592	25.70
9/16	0.5625	4 13/16	6 5/8	BF593	26.70
37/64	0.5781	4 13/16	6 5/8	BF594	28.10
19/32	0.5938	5 3/16	7 1/8	BF595	28.30
39/64	0.6094	5 3/16	7 1/8	BF596	30.00
5/8	0.6250	5 3/16	7 1/8	BF597	30.40
41/64	0.6406	5 3/16	7 1/8	BF598	39.30
21/32	0.6563	5 3/16	7 1/8	BF599	53.60
43/64	0.6719	5 5/8	7 5/8	BF600	55.00
11/16	0.6875	5 5/8	7 5/8	BF601	57.40
3/4	0.7500	5 1/2	8 1/16	BF602	53.00

Wire Ga. Size	Decimal"	L2"	L1"	Model No.	Price /Each
40	0.0980	1 3/8	2 3/8	BF641	2.23
39	0.0995	1 3/8	2 3/8	QD715	2.23
38	0.1015	1 7/16	2 1/2	BF640	2.15
37	0.1040	1 7/16	2 1/2	BF639	2.15
36	0.1065	1 7/16	2 1/2	QD714	2.23
35	0.1100	1 1/2	2 5/8	QD713	2.23
34	0.1110	1 1/2	2 5/8	BF638	2.23
33	0.1130	1 1/2	2 5/8	BF637	2.23
32	0.1160	1 5/8	2 3/4	QD712	2.23
31	0.1200	1 5/8	2 3/4	QD711	2.23
29	0.1360	1 3/4	2 7/8	QD709	2.15
28	0.1405	1 3/4	2 7/8	BF636	2.15
27	0.1440	1 7/8	3	BF635	2.36
26	0.1470	1 7/8	3	QD708	2.36
25	0.1495	1 7/8	3	QD707	2.43
24	0.1520	2	3 1/8	QD706	2.57
23	0.1540	2	3 1/8	QD705	2.57
22	0.1570	2	3 1/8	QD704	2.57
21	0.1590	2 1/8	3 1/4	QD703	2.64
20	0.1610	2 1/8	3 1/4	QD702	2.77
19	0.1660	2 1/8	3 1/4	BF634	2.77
18	0.1695	2 1/8	3 1/4	QD701	2.77
17	0.1730	2 3/16	3 3/8	BF633	3.11
16	0.1770	2 3/16	3 3/8	QD700	3.11
15	0.1800	2 3/16	3 3/8	QD699	3.17
14	0.1820	2 3/16	3 3/8	QD698	3.17
13	0.1850	2 5/16	3 1/2	QD697	3.17
12	0.1890	2 5/16	3 1/2	QD696	3.51
11	0.1910	2 5/16	3 1/2	QD695	3.51
10	0.1935	2 7/16	3 5/8	QD694	3.51
9	0.1960	2 7/16	3 5/8	BF632	3.51
8	0.1990	2 7/16	3 5/8	BF631	3.51
7	0.2010	2 7/16	3 5/8	QD693	3.51
6	0.2040	2 1/2	3 3/4	BF630	3.91
5	0.2055	2 1/2	3 3/4	BF629	3.91
4	0.2090	2 1/2	3 3/4	QD692	3.91
3	0.2130	2 1/2	3 3/4	QD691	3.91
2	0.2210	2 5/8	3 7/8	BF628	4.38
1	0.2280	2 5/8	3 7/8	BF627	4.38

Letter Size	Decimal"	L2"	L1"	Model No.	Price /Each
N	0.3020	3 1/16	4 3/8	QD689	7.34
O	0.3160	3 3/16	4 1/2	BF616	7.49
P	0.3230	3 5/16	4 5/8	BF617	8.11
Q	0.3320	3 7/16	4 3/4	BF618	8.51
R	0.3390	3 7/16	4 3/4	BF619	8.83
S	0.3480	3 1/2	4 7/8	QD690	9.72
T	0.3580	3 1/2	4 7/8	BF620	9.91
U	0.3680	3 5/8	5	BF621	10.90
V	0.3770	3 5/8	5	BF622	11.10
W	0.3860	3 3/4	5 1/8	BF623	11.70
X	0.3970	3 3/4	5 1/8	BF624	13.20
Y	0.4040	3 7/8	5 1/4	BF625	14.60
Z	0.4130	3 7/8	5 1/4	BF626	15.30

CUTTING TOOLS

JOBBER LENGTH – COBALT

- M42 cobalt provides wear and heat resistance
- Straight shank, 2 flute design
- Right hand cutting direction
- 135° split point, self-centring eliminates walking
- Bright finish

Applications

For general purpose drilling to heavy-duty operations in high tensile strength steel and alloys, stainless steels and other ferrous metals.

CLARKSON OSBORN

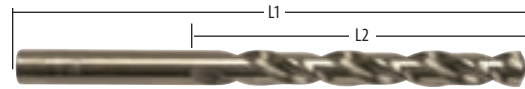

Fractional Size"	Decimal"	L2"	L1"	Model No.	Price /Each
1/64	0.0156	3/16	13/16	BG098	6.72
1/32	0.0312	13/32	1 3/16	BG099	5.32
3/64	0.0469	5/8	1 1/2	BG100	4.17
1/16	0.0625	25/32	1 11/16	BG101	4.00
5/64	0.0781	15/16	1 15/16	BG102	5.49
3/32	0.0938	13/16	2 1/4	BG103	3.55
7/64	0.1094	1 5/16	2 13/32	BG104	3.68
1/8	0.1250	1 7/16	2 9/16	BG105	3.81
9/64	0.1406	1 17/32	2 3/4	QD740	4.83
5/32	0.1562	1 11/16	2 15/16	BG106	4.83
11/64	0.1719	1 27/32	3 5/32	BG107	5.60
3/16	0.1875	2 1/16	3 3/8	BG108	6.02
13/64	0.2031	2 1/16	3 3/8	BG109	6.34
7/32	0.2188	2 1/4	3 21/32	BG110	6.57
15/64	0.2344	2 1/4	3 21/32	BG111	7.36
1/4	0.2500	2 1/2	3 31/32	BG112	8.17

Fractional Size"	Decimal"	L2"	L1"	Model No.	Price /Each
17/64	0.2656	2 23/32	4 9/32	BG113	9.40
9/32	0.2812	2 23/32	4 9/32	BG114	10.70
19/64	0.2969	2 15/16	4 19/32	BG115	12.00
5/16	0.3125	2 15/16	4 19/32	BG116	13.30
21/64	0.3281	2 15/16	4 19/32	BG117	14.80
11/32	0.3438	3 3/16	4 29/32	QD741	16.40
23/64	0.3594	3 3/16	4 29/32	BG118	17.90
3/8	0.3750	3 7/16	5 1/4	BG119	19.40
25/64	0.3906	3 7/16	5 1/4	BG120	20.30
13/32	0.4062	3 7/16	5 1/4	BG121	21.10
27/64	0.4219	3 11/16	5 9/32	BG122	22.90
7/16	0.4375	3 11/16	5 9/32	QD742	24.70
29/64	0.4531	3 11/16	5 9/32	BG123	35.30
15/32	0.4688	3 31/32	5 15/16	BG124	28.70
31/64	0.4844	3 31/32	5 15/16	BG125	30.70
1/2	0.5000	3 31/32	5 15/16	BG126	32.70

Letter Size	Decimal"	L2"	L1"	Model No.	Price /Each
A	0.2340	2 5/8	3 7/8	BG127	9.47
B	0.2380	2 3/4	4	BG128	10.90
C	0.2420	2 3/4	4	BG129	10.90
D	0.2460	2 3/4	4	BG130	12.20
E	0.2500	2 1/2	3 31/32	BG112	8.17
F	0.2570	2 7/8	4 1/8	BG131	10.90
G	0.2610	2 7/8	4 1/8	BG132	10.90
H	0.2660	2 7/8	4 1/8	BG133	12.20
I	0.2720	2 7/8	4 1/8	BG134	11.50
J	0.2770	2 7/8	4 1/8	BG135	12.20
K	0.2810	2 15/16	4 1/4	BG136	12.20
L	0.2900	2 15/16	4 1/4	BG137	13.90
M	0.2950	3 1/16	4 3/8	BG138	14.70

Letter Size	Decimal"	L2"	L1"	Model No.	Price /Each
N	0.3020	3 1/16	4 3/8	BG139	14.70
O	0.3160	3 3/16	4 1/2	BG140	16.20
P	0.3230	3 5/16	4 5/8	BG141	17.30
Q	0.3320	3 7/16	4 3/4	BG142	18.00
R	0.3390	3 7/16	4 3/4	BG143	18.00
S	0.3480	3 1/2	4 7/8	BG144	21.90
T	0.3580	3 1/2	4 7/8	BG145	21.90
U	0.3680	3 5/8	5	BG146	21.90
V	0.3770	3 5/8	5	BG147	24.10
W	0.3860	3 3/4	5 1/8	BG148	24.10
X	0.3970	3 3/4	5 1/8	BG149	24.10
Y	0.4040	3 7/8	5 1/4	BG150	25.70
Z	0.4130	3 7/8	5 1/4	BG151	27.90

Wire Gauge Size	Decimal"	L2"	L1"	Model No.	Price /Each
60	0.0400	15/32	1 5/16	BG211	4.53
59	0.0410	15/32	1 5/16	BG210	4.53
58	0.0420	9/16	1 7/16	BG209	4.53
57	0.0430	9/16	1 7/16	BG208	4.53
56	0.0465	5/8	1 1/2	BG207	4.53
55	0.0520	5/8	1 1/2	BG206	3.98
54	0.0550	11/16	1 9/16	BG205	3.98
53	0.0595	25/32	1 11/16	BG204	3.98
52	0.0635	25/32	1 11/16	BG203	3.66
51	0.0670	7/8	1 13/16	BG202	3.66
50	0.0700	7/8	1 13/16	BG201	3.66
49	0.0730	7/8	1 13/16	BG200	3.66
48	0.0760	15/16	1 15/16	BG199	3.66
47	0.0785	15/16	1 15/16	BG198	3.66
46	0.0810	15/16	1 15/16	BG197	3.66
45	0.0820	15/16	1 15/16	BG196	3.66
44	0.0860	1 1/16	2 3/32	BG195	3.66
43	0.0890	1 1/16	2 3/32	BG194	3.66
42	0.0935	1 3/16	2 1/4	BG193	3.66
41	0.0960	1 3/16	2 1/4	BG192	3.77
40	0.0980	1 3/16	2 1/4	BG191	3.77
39	0.0995	1 3/16	2 1/4	BG190	3.77
38	0.1015	1 3/16	2 1/4	BG189	3.77
37	0.1040	1 3/16	2 1/4	BG188	4.09
36	0.1065	1 5/16	2 13/32	BG187	4.09
35	0.1100	1 5/16	2 13/32	BG186	4.09
34	0.1110	1 5/16	2 13/32	BG185	4.09
33	0.1130	1 5/16	2 13/32	BG184	4.09
32	0.1160	1 5/16	2 13/32	BG183	4.32
31	0.1200	1 7/16	2 9/16	BG182	4.32

Wire Gauge Size	Decimal"	L2"	L1"	Model No.	Price /Each
30	0.1285	1 7/16	2 9/16	BG181	4.43
29	0.1360	1 17/32	2 3/4	BG180	4.62
28	0.1405	1 17/32	2 3/4	BG179	4.85
27	0.1440	1 17/32	2 3/4	BG178	5.19
26	0.1470	1 17/32	2 3/4	BG177	5.19
25	0.1495	1 11/16	2 15/16	BG176	5.19
24	0.1520	1 11/16	2 15/16	BG175	5.74
23	0.1540	1 11/16	2 15/16	BG174	5.74
22	0.1570	1 11/16	2 15/16	BG173	5.74
21	0.1590	1 11/16	2 15/16	BG172	5.74
20	0.1610	1 11/16	2 15/16	BG171	5.74
19	0.1660	1 11/16	2 15/16	BG170	5.74
18	0.1695	1 27/32	3 5/32	BG169	5.85
17	0.1730	1 27/32	3 5/32	BG168	6.40
16	0.1770	1 27/32	3 5/32	BG167	6.60
15	0.1800	1 27/32	3 5/32	BG166	7.06
14	0.1820	1 27/32	3 5/32	BG165	7.06
13	0.1850	1 27/32	3 5/32	BG164	7.06
12	0.1890	2 1/16	3 3/8	BG163	7.43
11	0.1910	2 1/16	3 3/8	BG162	7.43
10	0.1935	2 1/16	3 3/8	BG161	7.43
9	0.1960	2 1/16	3 3/8	BG160	7.43
8	0.1990	2 1/16	3 3/8	BG159	7.43
7	0.2010	2 1/16	3 3/8	BG158	7.43
6	0.2040	2 1/16	3 3/8	BG157	9.47
5	0.2055	2 1/16	3 3/8	BG156	9.47
4	0.2090	2 1/4	3 21/32	BG155	9.47
3	0.2130	2 1/4	3 21/32	BG154	9.47
2	0.2210	2 1/4	3 21/32	BG153	10.10
1	0.2280	2 1/4	3 21/32	BG152	10.10

JOBBER LENGTH – COBALT (CONT'D)

Size mm	DEC	L2mm	L1mm	Model No.	Price /Each
1.00	0.0394	12.0	34.0	BI021	7.11
1.50	0.0591	18.0	40.0	BI022	5.45
1.60	0.0630	20.0	43.0	BI023	7.85
1.70	0.0669	20.0	43.0	BI024	7.64
1.80	0.0709	22.0	46.0	BI025	7.45
1.90	0.0748	22.0	46.0	BI026	7.32
2.00	0.0787	24.0	49.0	BI027	4.81
2.10	0.0827	24.0	49.0	BI028	7.17
2.20	0.0866	27.0	53.0	BI029	7.11
2.25	0.0886	27.0	53.0	BI030	7.11
2.30	0.0906	27.0	53.0	BI031	7.11
2.40	0.0945	30.0	57.0	BI032	7.02
2.50	0.0984	30.0	57.0	BI033	4.72
2.60	0.1024	30.0	57.0	BI034	7.13
2.70	0.1063	33.0	61.0	BI035	7.17
2.80	0.1102	33.0	61.0	BI036	7.17
2.90	0.1142	33.0	61.0	BI037	7.28
3.00	0.1181	33.0	61.0	BI038	4.94
3.10	0.1220	36.0	65.0	BI039	7.53
3.20	0.1260	36.0	65.0	BI040	7.64
3.30	0.1299	36.0	65.0	BI041	5.19
3.40	0.1339	39.0	70.0	BI042	7.89
3.50	0.1378	39.0	70.0	BI043	5.38
3.60	0.1417	39.0	70.0	BI044	8.28
3.70	0.1457	39.0	70.0	BI045	8.43
3.75	0.1476	39.0	70.0	BI046	10.20
3.80	0.1496	43.0	75.0	BI047	8.57
3.90	0.1535	43.0	75.0	BI048	8.83
4.00	0.1575	43.0	75.0	BI049	6.00
4.10	0.1614	43.0	75.0	BI050	9.23
4.20	0.1654	43.0	75.0	BI051	9.45
4.25	0.1673	43.0	75.0	BI052	9.77
4.30	0.1693	47.0	80.0	BI053	9.64
4.40	0.1732	47.0	80.0	BI054	9.96
4.50	0.1772	47.0	80.0	BI055	6.77
4.60	0.1811	47.0	80.0	BI056	10.40
4.70	0.1850	47.0	80.0	BI057	10.70
4.80	0.1890	52.0	86.0	BI058	11.00
4.90	0.1929	52.0	86.0	BI059	11.30
5.00	0.1969	52.0	86.0	BI060	7.68

Size mm	DEC	L2mm	L1mm	Model No.	Price /Each
5.10	0.2008	52.0	86.0	BI061	11.90
5.20	0.2047	52.0	86.0	BI062	12.30
5.30	0.2087	52.0	86.0	BI063	12.60
5.40	0.2126	57.0	93.0	BI064	12.90
5.50	0.2165	57.0	93.0	BI065	8.89
5.60	0.2205	57.0	93.0	BI066	13.60
5.70	0.2244	57.0	93.0	BI067	14.00
5.80	0.2283	57.0	93.0	TBL002	14.50
5.90	0.2323	57.0	93.0	TBL003	14.70
6.00	0.2362	57.0	93.0	BI068	10.10
6.10	0.2402	63.0	101.0	BI069	15.60
6.20	0.2441	63.0	101.0	BI070	16.10
6.30	0.2480	63.0	101.0	BI071	16.70
6.40	0.2520	63.0	101.0	BI072	17.00
6.50	0.2559	63.0	101.0	BI073	11.60
6.60	0.2598	63.0	101.0	BI074	17.90
6.70	0.2638	63.0	101.0	TBL004	18.10
6.80	0.2677	69.0	109.0	BI075	18.70
6.90	0.2717	69.0	109.0	BI076	19.00
7.00	0.2756	69.0	109.0	BI077	13.10
7.10	0.2795	69.0	109.0	TBL005	20.40
7.20	0.2835	69.0	109.0	BI078	21.00
7.30	0.2874	69.0	109.0	BI079	21.60
7.40	0.2913	69.0	109.0	BI080	22.10
7.50	0.2953	69.0	109.0	BI081	15.00
7.60	0.2992	75.0	117.0	BI082	23.00
7.70	0.3031	75.0	117.0	BI083	23.60
7.80	0.3071	75.0	117.0	BI084	24.10
7.90	0.3110	75.0	117.0	BI085	24.90
8.00	0.3150	75.0	117.0	BI086	17.00
8.10	0.3189	75.0	117.0	BI087	26.10
8.20	0.3228	75.0	117.0	BI088	26.90
8.30	0.3268	75.0	117.0	BI089	27.50
8.40	0.3307	75.0	117.0	BI090	28.10
8.50	0.3346	75.0	117.0	BI091	19.00
8.60	0.3386	81.0	125.0	BI092	29.50
8.70	0.3425	81.0	125.0	BI093	30.30
8.80	0.3465	81.0	125.0	BI094	30.90
8.90	0.3504	81.0	125.0	BI095	31.40
9.00	0.3543	81.0	125.0	BI096	21.90

Size mm	DEC	L2mm	L1mm	Model No.	Price /Each
9.10	0.3583	81.0	125.0	BI097	33.20
9.20	0.3622	81.0	125.0	BI098	34.00
9.30	0.3661	81.0	125.0	BI099	34.90
9.40	0.3701	81.0	125.0	BI100	35.50
9.50	0.3740	81.0	125.0	BI101	24.10
9.60	0.3780	87.0	133.0	TBL006	37.10
9.70	0.3819	87.0	133.0	BI102	37.70
9.80	0.3858	87.0	133.0	BI103	39.10
9.90	0.3898	87.0	133.0	BI104	40.00
10.00	0.3937	87.0	133.0	BI105	27.20
10.10	0.3976	87.0	133.0	BI106	44.80
10.20	0.4016	87.0	133.0	BI107	42.80
10.30	0.4055	87.0	133.0	BI108	44.80
10.40	0.4094	87.0	133.0	BI109	46.80
10.50	0.4134	87.0	133.0	BI110	45.70
10.60	0.4173	87.0	133.0	BI111	53.00
10.70	0.4213	94.0	142.0	BI112	55.30
10.80	0.4252	94.0	142.0	BI113	57.30
10.90	0.4291	94.0	142.0	BI114	59.50
11.00	0.4331	94.0	142.0	BI115	33.40
11.10	0.4370	94.0	142.0	BI116	60.40
11.20	0.4409	94.0	142.0	BI117	62.10
11.30	0.4449	94.0	142.0	BI118	62.90
11.40	0.4488	94.0	142.0	BI119	63.50
11.50	0.4528	94.0	142.0	BI120	56.10
11.60	0.4567	94.0	142.0	BI121	64.90
11.70	0.4606	94.0	142.0	BI122	65.80
11.80	0.4646	94.0	142.0	BI123	65.80
11.90	0.4685	101.0	151.0	BI124	66.30
12.00	0.4724	101.0	151.0	BI125	41.10
12.10	0.4764	101.0	151.0	BI126	70.00
12.20	0.4803	101.0	151.0	BI127	81.10
12.30	0.4843	101.0	151.0	BI128	82.20
12.40	0.4882	101.0	151.0	BI129	84.20
12.50	0.4921	101.0	151.0	BI130	68.60
13.00	0.5118	101.0	151.0	BI131	66.10
13.50	0.5315	101.0	151.0	BI132	83.10
14.00	0.5512	101.0	151.0	BI133	90.70
14.50	0.5709	114.0	169.0	BI134	94.10

Can't find what
you're looking for?
Call us today!



CUTTING TOOLS

AIRCRAFT EXTENSION DRILLS

- NAS907B (National Aerospace Standard)
- M7 high speed steel
- Right hand cutting direction, standard spiral
- 135° split point, self-centring eliminates walking
- Black oxide finish

Application

Portable or machine drilling in hard steels, stainless steel and other hard materials.

CLARKSON OSBORN



FRACTIONAL SIZES

Fractional Size"	L2"	6" Model No.	Price /Each	12" Model No.	Price /Each
3/64	3/4	BH521	12.00	TBL179	22.70
1/16	7/8	BH522	5.26	BH584	17.10
5/64	1	BH523	5.26	BH585	17.10
3/32	1 1/4	BH524	4.32	BH586	17.10
7/64	1 1/2	BH525	4.36	BH587	13.60
1/8	1 5/8	BH526	4.36	BH588	13.60
9/64	1 3/4	BH527	5.60	TBL180	13.60
5/32	2	BH528	5.60	BH589	13.60
11/64	2 1/8	BH529	6.15	BH590	15.20
3/16	2 5/16	BH530	6.15	BH591	15.20
13/64	2 7/16	BH531	7.53	TBL181	19.50
7/32	2 1/2	BH532	7.53	BH592	17.50
15/64	2 5/8	BH533	7.62	TBL182	18.80
1/4	2 3/4	BH534	7.62	BH593	18.80
17/64	2 7/8	BH535	18.10	TBL183	22.40

Fractional Size"	L2"	6" Model No.	Price /Each	12" Model No.	Price /Each
9/32	2 15/16	BH536	19.40	BH594	23.70
19/64	3 1/16	BH537	22.00	TBL184	26.80
5/16	3 3/16	BH538	24.70	BH595	30.20
21/64	3 5/16	TBL160	25.80	TBL185	31.50
11/32	3 7/16	BH539	25.80	BH596	31.70
23/64	3 1/2	TBL161	28.40	TBL186	35.00
3/8	3 5/8	BH540	30.00	BH597	37.00
25/64	3 3/4	TBL162	32.20	BH598	39.10
13/32	3 7/8	TBL163	32.20	BH599	39.10
27/64	3 15/16	BH541	34.40	TBL187	42.00
7/16	4 1/16	TBL164	36.10	BH600	44.10
29/64	4 3/16	TBL165	38.40	BH601	46.60
15/32	4 5/16	TBL166	41.30	BH602	50.00
31/64	4 3/8	TBL167	41.30	BH603	50.00
1/2	4 1/2	TBL168	43.00	BH604	52.70

NUMBER GAUGE SIZES

Number Size	L2"	6" Model No.	Price /Each	12" Model No.	Price /Each
#1	2 5/8	BH549	8.74	TBL188	20.50
#2	2 5/8	BH550	8.74	TBL189	20.50
#3	2 1/2	BH551	7.81	BH631	19.20
#4	2 1/2	TBL169	7.81	BH632	19.40
#5	2 1/2	BH552	7.81	BH633	19.20
#6	2 1/2	TBL170	7.81	BH634	19.20
#7	2 7/16	BH553	7.81	BH635	19.20
#8	2 7/16	BH554	7.66	BH636	19.20
#9	2 7/16	BH555	7.53	BH637	17.10
#10	2 7/16	BH556	7.09	BH638	17.10
#11	2 5/16	BH557	6.51	BH639	17.10
#12	2 5/16	BH558	6.51	BH640	17.10
#13	2 5/16	BH559	6.51	BH641	17.10
#14	2 3/16	BH560	6.51	BH642	17.10
#15	2 3/16	TBL171	6.51	BH643	17.10
#16	2 3/16	TBL172	6.51	BH644	17.10
#17	2 3/16	TBL173	6.51	BH645	17.10
#18	2 1/8	BH561	6.51	BH646	17.10
#19	2 1/8	TBL174	6.51	BH647	17.10
#20	2 1/8	BH562	5.91	BH648	15.60
#21	2 1/8	BH563	5.91	BH649	15.60
#22	2	BH565	5.91	BH650	15.60
#23	2	TBL175	5.91	BH651	15.60
#24	2	TBL176	5.91	BH652	15.60
#25	1 7/8	BH566	5.91	BH653	15.60
#26	1 7/8	TBL177	5.91	BH654	15.60
#27	1 7/8	BH567	5.91	BH655	15.60
#28	1 3/4	TBL178	5.91	BH656	15.60
#29	1 3/4	BH568	5.91	BH657	15.60
#30	1 5/8	BH569	4.89	BH658	15.60

Number Size	L2"	6" Model No.	Price /Each	12" Model No.	Price /Each
#31	1 5/8	BH570	4.89	BH659	15.60
#32	1 5/8	TBL190	4.89	BH660	15.60
#33	1 1/2	TBL191	4.89	BH661	16.10
#34	1 1/2	TBL192	4.89	BH662	16.10
#35	1 1/2	TBL193	4.89	BH663	16.10
#36	1 7/16	BH571	5.00	BH664	16.10
#37	1 7/16	TBL194	5.00	BH665	16.10
#38	1 7/16	TBL195	5.00	BH666	16.10
#39	1 3/8	BH572	5.17	BH667	16.10
#40	1 3/8	BH573	4.43	BH668	15.40
#41	1 3/8	TBL196	4.43	TBL225	15.40
#42	1 1/4	BH574	4.43	TBL226	15.40
#43	1 1/4	BH575	5.62	TBL227	19.60
#44	1 1/8	TBL197	5.62	TBL228	19.60
#45	1 1/8	TBL198	5.62	TBL229	19.60
#46	1 1/8	BH576	5.62	TBL230	19.60
#47	1	BH577	5.62	TBL231	19.60
#48	1	TBL199	5.62	TBL232	19.60
#49	1	TBL200	5.62	BH669	19.60
#50	1	TBL201	5.62	TBL233	19.60
#51	1	BH578	5.62	TBL234	20.90
#52	7/8	BH579	5.62	BH670	20.90
#53	7/8	BH580	11.10	TBL235	20.10
#54	7/8	BH581	11.10	TBL236	20.10
#55	7/8	BH582	11.10	TBL237	20.10
#56	3/4	TBL202	11.10	TBL238	20.10
#57	3/4	TBL203	13.40	TBL239	20.10
#58	11/16	BH583	13.40	BH671	22.60
#59	11/16	TBL204	13.40	TBL240	22.60
#60	11/16	TBL205	13.40	TBL241	22.60

LETTER GAUGE SIZES

Letter Size	L2"	6" Model No.	Price /Each	12" Model No.	Price /Each
A	2 5/8	TBL206	11.50	BH605	22.40
B	2 3/4	BH542	11.50	BH606	22.40
C	2 3/4	TBL207	11.50	BH607	22.40
D	2 3/4	BH543	11.50	BH608	22.40
E	2 3/4	BH534	7.62	BH593	18.80
F	2 7/8	BH544	12.70	BH610	26.60
G	2 7/8	TBL209	19.90	BH611	26.60
H	2 7/8	BH545	20.90	BH612	26.60
I	2 7/8	TBL210	20.90	BH613	26.60
J	2 7/8	TBL211	20.90	BH614	26.60
K	2 15/16	TBL212	20.90	BH615	26.60
L	2 15/16	TBL213	24.20	BH616	28.10
M	3 1/16	TBL214	24.20	BH617	28.10

Letter Size	L2"	6" Model No.	Price /Each	12" Model No.	Price /Each
N	3 1/16	BH546	27.20	BH618	30.70
O	3 3/16	BH547	28.40	BH619	32.90
P	3 5/16	TBL215	28.40	BH620	32.90
Q	3 7/16	TBL216	28.40	BH621	34.40
R	3 7/16	TBL217	28.40	BH622	35.90
S	3 1/2	TBL218	31.70	BH623	37.60
T	3 1/2	TBL219	31.70	BH624	37.60
U	3 5/8	BH548	33.40	BH625	37.60
V	3 5/8	TBL220	35.20	BH626	39.90
W	3 3/4	TBL221	35.20	BH627	39.90
X	3 3/4	TBL222	35.20	BH628	42.20
Y	3 7/8	TBL223	35.20	BH629	42.20
Z	3 7/8	TBL224	37.50	BH630	44.50

TAPER LENGTH DRILLS

- High speed steel
- 118° angle point
- 2-flute design
- Black oxide finish

Applications

Taper length drills are general purpose drills with increased cutting length. They are manufactured with straight shanks of the same diameter as that of the flute diameter.



Fractional Size"	Decimal" Equiv	L2"	L1"	Model No.	Price /Each
1/16	0.0625	1 3/4	3	BG665	4.98
3/32	0.0938	2 1/4	4 1/4	BG667	6.60
7/64	0.1094	2 1/2	4 5/8	BG668	8.30
1/8	0.1250	2 3/4	5 1/8	BG669	8.64
9/64	0.1406	3	5 3/8	BG670	10.90
5/32	0.1562	3	5 3/8	BG671	10.30
11/64	0.1719	3 3/8	5 3/4	BG672	12.10
3/16	0.1875	3 3/8	5 3/4	BG673	10.50
13/64	0.2031	3 5/8	6	BG674	13.60
7/32	0.2188	3 5/8	6	BG675	14.40
15/64	0.2344	3 3/4	6 1/8	BG676	14.40
1/4	0.2500	3 3/4	6 1/8	BG677	12.20
17/64	0.2656	3 7/8	6 1/4	BG678	15.20
9/32	0.2812	3 7/8	6 1/4	BG679	14.90
19/64	0.2969	4	6 3/8	BG680	16.50
5/16	0.3125	4	6 3/8	BG681	15.10

Fractional Size"	Decimal" Equiv	Flute Length"	Overall Length"	Model No.	Price /Each
21/64	0.3281	4 1/8	6 1/2	BG682	17.60
11/32	0.3438	4 1/8	6 1/2	BG683	16.70
23/64	0.3594	4 1/4	6 3/4	BG684	19.40
3/8	0.3750	4 1/4	6 3/4	BG685	19.40
25/64	0.3906	4 3/8	7	BG686	21.00
13/32	0.4062	4 3/8	7	BG687	20.70
27/64	0.4219	4 5/8	7 1/4	BG688	22.30
7/16	0.4375	4 5/8	7 1/4	BG689	22.80
29/64	0.4531	4 3/4	7 1/2	BG690	25.30
15/32	0.4688	4 3/4	7 1/2	BG691	26.40
31/64	0.4844	4 3/4	7 3/4	BG692	28.70
1/2	0.5000	4 3/4	7 3/4	BG693	27.50
33/64	0.5156	4 3/4	8	BG694	33.80
17/32	0.5312	4 3/4	8	BG695	33.10
35/64	0.5469	4 7/8	8 1/4	BG696	37.80
9/16	0.5625	4 7/8	8 1/4	BG697	35.10
37/64	0.5781	4 7/8	8 3/4	BG698	41.60
19/32	0.5938	4 7/8	8 3/4	BG699	41.60
39/64	0.6094	4 7/8	8 3/4	BG700	43.60
5/8	0.6250	4 7/8	8 3/4	BG701	42.60

REDUCED SHANK DRILL BITS – HIGH SPEED STEEL

- Hyper series - maintenance duty
- 1/2" shank
- Right hand cutting direction
- 118° point, 2-flute design
- Black oxide finish

Applications:

General purpose machine drilling of larger diameter holes in steels, cast iron, alloys and other ferrous and non-ferrous materials.

Model No. BN052 5 pc set; 9/16, 5/8, 3/4, 7/8, 1

Model No. BN053 8 pc set; 9/16, 5/8, 11/16, 3/4, 13/16, 7/8, 15/16, 1



Fractional Size"	L2"	L1"	Model No.	Price /Each
33/64	3	6	BN029	21.70
17/32	3	6	QR069	21.70
35/64	3	6	BN030	25.40
9/16	3	6	QR189	25.40
37/64	3	6	BN031	27.50
19/32	3	6	QR062	27.50
39/64	3	6	BN032	29.90
5/8	3	6	QR041	29.90
41/64	3	6	BN033	30.10
21/32	3	6	QR039	30.50
43/64	3	6	BN034	30.60
11/16	3	6	QR059	31.00
45/64	3	6	BN035	31.30
23/32	3	6	QR063	31.50
47/64	3	6	BN036	31.80
3/4	3	6	QR033	31.90
49/64	3	6	BN037	32.00
25/32	3	6	QR037	32.70
51/64	3	6	BN038	32.70
13/16	3	6	QR034	32.70



Fractional Size"	L2"	L1"	Model No.	Price /Each
53/64	3	6	BN045	34.30
27/32	3	6	BN039	33.60
55/64	3	6	BN046	35.60
7/8	3	6	QR035	34.90
57/64	3	6	BN047	37.20
29/32	3	6	BN040	35.50
59/64	3	6	BN048	39.70
15/16	3	6	QR065	38.10
61/64	3	6	BN049	41.90
31/32	3	6	BN041	42.40
63/64	3	6	BN050	46.40
1	3	6	QR036	46.90
11/16	3	6	QR053	56.80
1 1/8	3	6	QR067	62.50
1 3/16	3	6	QR068	73.10
1 1/4	3	6	QR056	81.60
1 5/16	3	6	BN051	86.00
1 3/8	3	6	BN042	99.10
1 7/16	3	6	BN043	106.00
1 1/2	3	6	BN044	116.00

CUTTING TOOLS

REDUCED SHANK DRILL BITS – HIGH SPEED STEEL

- Industrial duty
- 1/2" shank
- Right hand cutting direction
- 118° point, 2-flute design
- Black oxide & bright finish

Applications:

General purpose machine drilling of larger diameter holes in steels, cast iron, alloys and other ferrous and non-ferrous materials.

FRACTIONAL SIZES

Fractional Size"	Decimal" Equiv	L2	L1	Model No.	Price /Each
17/32	0.5313	3"	6"	BH387	33.80
9/16	0.5625	3"	6"	BH388	35.60
19/32	0.5938	3"	6"	BH389	38.60
5/8	0.6250	3"	6"	BH390	40.20
21/32	0.6563	3"	6"	BH391	42.90
11/16	0.6875	3"	6"	BH392	44.80
23/32	0.7188	3"	6"	BH393	47.60
3/4	0.7500	3"	6"	BH394	49.50
25/32	0.7813	3"	6"	BH395	51.70
13/16	0.8125	3"	6"	BH396	53.70
27/32	0.8438	3"	6"	BH397	57.20
7/8	0.8750	3"	6"	BH398	58.70
29/32	0.9063	3"	6"	BH399	61.40

METRIC SIZES

Metric mm	Decimal" Equiv	L2	L1	Model No.	Price /Each
13.00	0.5118	75.0mm	150.0mm	BH413	39.50
13.50	0.5315	75.0mm	150.0mm	BH414	62.40
14.00	0.5512	75.0mm	150.0mm	BH415	43.90
14.50	0.5709	75.0mm	150.0mm	BH416	69.30
15.00	0.5906	75.0mm	150.0mm	BH417	48.30
15.50	0.6102	75.0mm	150.0mm	BH418	76.40
16.00	0.6299	75.0mm	150.0mm	BH419	53.60
16.50	0.6496	75.0mm	150.0mm	BH420	84.50
17.00	0.6693	75.0mm	150.0mm	BH421	58.80
17.50	0.6890	75.0mm	150.0mm	BH422	92.80

REDUCED SHANK DRILL BITS – COBALT

- M42 cobalt
- 1/2" shank
- Right hand cutting direction
- 118° point, 2-flute design
- Bright finish

Applications:

General purpose to heavy –duty operations in high tensile strength steels and alloys, stainless steels and other ferrous and non-ferrous materials.

Fractional Size"	Decimal" Equiv	L2	L1	Model No.	Price /Each
33/64	0.5156	3"	6"	BH435	42.80
17/32	0.5313	3"	6"	BH436	44.40
35/64	0.5469	3"	6"	BH437	46.00
9/16	0.5625	3"	6"	BH438	42.50
37/64	0.5781	3"	6"	BH439	54.20
19/32	0.5938	3"	6"	BH440	50.10
39/64	0.6094	3"	6"	BH441	51.90
5/8	0.6250	3"	6"	BH442	48.00
41/64	0.6406	3"	6"	BH443	60.90
21/32	0.6563	3"	6"	BH444	58.30
43/64	0.6719	3"	6"	BH445	60.90
11/16	0.6875	3"	6"	BH446	56.30
45/64	0.7031	3"	6"	BH447	66.70
23/32	0.7188	3"	6"	BH448	61.70
47/64	0.7344	3"	6"	BH449	70.10
3/4	0.7500	3"	6"	BH450	64.90
49/64	0.7656	3"	6"	BH451	71.20
25/32	0.7813	3"	6"	BH452	65.90

CLARKSON OSBORN

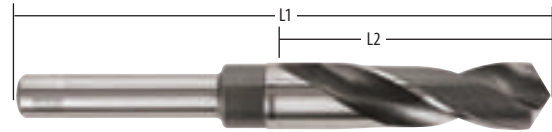

Fractional Size"	Decimal" Equiv	L2	L1	Model No.	Price /Each
15/16	0.9375	3"	6"	BH400	65.50
31/32	0.9688	3"	6"	BH401	70.20
1	1.0000	3"	6"	BH402	77.60
1 1/32	1.0313	3"	6"	BH403	93.80
1 1/16	1.0625	3"	6"	BH404	97.50
1 3/32	1.0938	3"	6"	BH405	102.00
1 1/8	1.1250	3"	6"	BH406	109.00
1 5/32	1.1563	3"	6"	BH407	109.00
1 3/16	1.1875	3"	6"	BH408	121.00
1 1/4	1.2500	3"	6"	BH409	133.00
1 3/8	1.3750	3"	6"	BH411	182.00
1 1/2	1.5000	3"	6"	BH412	219.00

Metric mm	Decimal" Equiv	L2	L1	Model No.	Price /Each
18.00	0.7087	75.0 mm	150.0 mm	BH423	64.60
18.50	0.7283	75.0 mm	150.0 mm	BH424	102.00
19.00	0.7480	75.0 mm	150.0 mm	BH425	71.00
19.50	0.7677	75.0 mm	150.0 mm	BH426	112.00
20.00	0.7874	75.0 mm	150.0 mm	BH427	77.60
21.00	0.8268	75.0 mm	150.0 mm	BH428	85.00
22.00	0.8661	75.0 mm	150.0 mm	BH429	92.50
23.00	0.9055	75.0 mm	150.0 mm	BH430	101.00
24.00	0.9449	75.0 mm	150.0 mm	BH431	109.00
25.00	0.9843	75.0 mm	150.0 mm	BH432	118.00

CLARKSON OSBORN

Fractional Size"	Decimal" Equiv	L2	L1	Model No.	Price /Each
51/64	0.7969	3"	6"	BH453	72.30
13/16	0.8125	3"	6"	BH454	66.90
53/64	0.8281	3"	6"	BH455	73.30
27/32	0.8438	3"	6"	BH456	67.80
55/64	0.8594	3"	6"	BH457	86.80
7/8	0.8750	3"	6"	BH458	80.30
57/64	0.8906	3"	6"	BH459	90.70
29/32	0.9063	3"	6"	BH460	83.90
59/64	0.9219	3"	6"	BH461	96.40
15/16	0.9375	3"	6"	BH462	89.20
61/64	0.9531	3"	6"	BH463	102.00
31/32	0.9688	3"	6"	BH464	94.70
63/64	0.9844	3"	6"	BH465	110.00
1	1.0000	3"	6"	BH466	94.70
1 5/32	1.1563	3"	6"	BH471	217.00
1 1/4	1.2500	3"	6"	BH473	251.00
1 5/16	1.3125	3"	6"	BH474	354.00

MORSE TAPER SHANK DRILLS

- High Speed Steel
- 2-flute design
- Right hand cutting direction
- 118° point
- Black finish

Applications

Used with either portable or stationary machines with a taper socket spindle. General purpose drills for steels, cast iron and other ferrous and non-ferrous metals and alloys.



Fractional Size"	Morse Taper	Decimal" Equiv	L2mm	L1mm	Model No.	Price /Each
1/8	#1	0.1250	36.0	117.0	BG786	14.30
9/64	#1	0.1406	39.0	120.0	BG787	15.90
5/32	#1	0.1563	43.0	123.0	BG788	15.20
11/64	#1	0.1719	47.0	128.0	BG789	17.80
3/16	#1	0.1875	53.0	133.0	BG790	16.10
13/64	#1	0.2031	53.0	133.0	BG791	18.00
7/32	#1	0.2188	57.0	138.0	BG792	18.00
15/64	#1	0.2344	57.0	138.0	BG793	19.50
1/4	#1	0.2500	63.0	144.0	BG794	17.60
17/64	#1	0.2656	69.0	150.0	BG795	17.80
9/32	#1	0.2813	69.0	150.0	BG796	17.80
19/64	#1	0.2969	75.0	156.0	BG797	20.90
5/16	#1	0.3125	75.0	156.0	BG798	18.50
21/64	#1	0.3281	75.0	156.0	BG799	24.00
11/32	#1	0.3438	81.0	162.0	BG800	25.00
23/64	#1	0.3594	81.0	162.0	BG801	28.50
3/8	#1	0.3750	87.0	168.0	BG802	29.00
25/64	#1	0.3906	87.0	168.0	BG803	29.50
13/32	#1	0.4063	87.0	168.0	BG804	29.30
27/64	#1	0.4219	94.0	175.0	BG805	30.30
7/16	#1	0.4375	94.0	175.0	BG806	31.30
29/64	#1	0.4531	94.0	175.0	BG807	33.40
15/32	#1	0.4688	101.0	182.0	BG808	34.70
31/64	#2	0.4844	4 3/8"	8 1/4"	BG809	39.60
1/2	#2	0.5000	4 3/8"	8 1/4"	BG810	38.70
33/64	#2	0.5156	4 5/8"	8 1/2"	BG811	42.90
17/32	#2	0.5313	4 5/8"	8 1/2"	BG812	42.30
35/64	#2	0.5469	4 7/8"	8 3/4"	BG813	46.60
9/16	#2	0.5625	4 7/8"	8 3/4"	BG814	46.10
37/64	#2	0.5781	4 7/8"	8 3/4"	BG815	49.50
19/32	#2	0.5938	4 7/8"	8 3/4"	BG816	48.30
39/64	#2	0.6094	4 7/8"	8 3/4"	BG817	52.50
5/8	#2	0.6250	4 7/8"	8 3/4"	BG818	50.70
41/64	#2	0.6406	5 1/8"	9"	BG819	58.20
21/32	#2	0.6563	5 1/8"	9"	BG820	57.20
43/64	#2	0.6719	5 3/8"	9 1/4"	BG821	62.80
11/16	#2	0.6875	5 3/8"	9 1/4"	BG822	61.00
45/64	#2	0.7031	5 5/8"	9 1/2"	BG823	66.90
23/32	#2	0.7188	5 5/8"	9 1/2"	BG824	65.30
47/64	#2	0.7344	5 7/8"	9 3/4"	BG825	71.60
3/4	#2	0.7500	5 7/8"	9 3/4"	BG826	71.60
49/64	#2	0.7656	6"	9 7/8"	BG827	81.80
25/32	#2	0.7813	6"	9 7/8"	BG828	81.60
51/64	#3	0.7969	6 1/8"	10 3/4"	BG829	89.10
13/16	#3	0.8125	6 1/8"	10 3/4"	BG830	87.10
53/64	#3	0.8281	6 1/8"	10 3/4"	BG831	92.90
27/32	#3	0.8438	6 1/8"	10 3/4"	BG832	90.10
55/64	#3	0.8594	6 1/8"	10 3/4"	BG833	96.10
7/8	#3	0.8750	6 1/8"	10 3/4"	BG834	92.90
57/64	#3	0.8906	6 1/8"	10 3/4"	BG835	98.30
29/32	#3	0.9063	6 1/8"	10 3/4"	BG836	98.30
59/64	#3	0.9219	6 1/8"	10 3/4"	BG837	104.00
15/16	#3	0.9375	6 1/8"	10 3/4"	BG838	97.60
61/64	#3	0.9531	6 3/8"	11"	BG839	107.00
31/32	#3	0.9688	6 3/8"	11"	BG840	107.00
63/64	#3	0.9844	6 3/8"	11"	BG841	111.00
1	#3	1.0000	6 3/8"	11"	BG842	107.00
1 1/64	#3	1.0156	6 1/2"	11 1/8"	BG843	123.00
1 1/32	#3	1.0313	6 1/2"	11 1/8"	BG844	118.00
1 3/64	#3	1.0469	6 5/8"	11 1/4"	BG845	130.00
1 1/16	#3	1.0625	6 5/8"	11 1/4"	BG846	123.00
1 5/64	#4	1.0781	6 7/8"	12 1/2"	BG847	149.00

Fractional Size"	Morse Taper	Decimal" Equiv	L2	L1	Model No.	Price /Each
1 3/32	#4	1.0938	6 7/8"	12 1/2"	BG848	144.00
1 7/64	#4	1.1094	7 1/8"	12 3/4"	BG849	154.00
1 1/8	#4	1.1250	7 1/8"	12 3/4"	BG850	151.00
1 9/64	#4	1.1406	7 1/4"	12 7/8"	BG851	165.00
1 5/32	#4	1.1563	7 1/4"	12 7/8"	BG852	156.00
1 11/64	#4	1.1719	7 3/8"	13"	BG853	168.00
1 3/16	#4	1.1875	7 3/8"	13"	BG854	165.00
1 13/64	#4	1.2031	7 1/2"	13 1/8"	BG855	178.00
1 7/32	#4	1.2188	7 1/2"	13 1/8"	BG856	175.00
1 15/64	#4	1.2344	7 7/8"	13 1/2"	BG857	194.00
1 19/64	#4	1.2500	7 7/8"	13 1/2"	BG858	185.00
1 17/64	#4	1.2656	8 1/2"	14 1/8"	BG859	225.00
1 9/32	#4	1.2813	8 1/2"	14 1/8"	BG860	222.00
1 19/64	#4	1.2969	8 5/8"	14 1/4"	BG861	238.00
1 5/16	#4	1.3125	8 5/8"	14 1/4"	BG862	226.00
1 21/64	#4	1.3281	8 3/4"	14 3/8"	BG863	247.00
1 11/32	#4	1.3438	8 3/4"	14 3/8"	BG864	238.00
1 23/64	#4	1.3594	8 7/8"	14 1/2"	BG865	252.00
1 3/8	#4	1.3750	8 7/8"	14 1/2"	BG866	242.00
1 25/64	#4	1.3906	9"	14 5/8"	BG867	259.00
1 13/32	#4	1.4063	9"	14 5/8"	BG868	259.00
1 27/64	#4	1.4219	9 1/8"	14 1/4"	BG869	269.00
1 7/16	#4	1.4375	9 1/8"	14 1/4"	BG870	262.00
1 29/64	#4	1.4531	9 1/4"	14 7/8"	BG871	279.00
1 15/32	#4	1.4688	9 1/4"	14 7/8"	BG872	276.00
1 31/64	#4	1.4844	9 3/8"	15"	BG873	286.00
1 1/2	#4	1.5000	9 3/8"	15"	BG874	277.00
1 33/64	#5	1.5156	9 3/8"	16 3/8"	BG875	358.00
1 17/32	#5	1.5313	9 3/8"	16 3/8"	BG876	326.00
1 35/64	#5	1.5469	9 5/8"	16 5/8"	BG877	383.00
1 9/16	#5	1.5625	9 5/8"	16 5/8"	BG878	341.00
1 19/32	#5	1.5938	9 7/8"	16 7/8"	BG879	370.00
1 5/8	#5	1.6250	10"	17"	BG880	378.00
1 21/32	#5	1.6563	10 1/8"	17 1/8"	BG881	397.00
1 11/16	#5	1.6875	10 1/8"	17 1/8"	BG882	408.00
1 23/32	#5	1.7188	10 1/8"	17 1/8"	BG883	425.00
1 3/4	#5	1.7500	10 1/8"	17 1/8"	BG884	436.00
1 25/32	#5	1.7813	10 1/8"	17 1/8"	BG885	453.00
1 13/16	#5	1.8125	10 1/8"	17 1/8"	BG886	465.00
1 7/8	#5	1.8750	10 3/8"	17 3/8"	BG887	472.00
1 15/16	#5	1.9375	10 3/8"	17 3/8"	BG888	509.00
1 31/32	#5	1.9688	10 3/8"	17 3/8"	BG889	520.00
2	#5	2.0000	10 3/8"	17 3/8"	BG890	525.00
2 1/16	#5	2.0625	10 1/4"	17 3/8"	BG891	560.00
2 1/8	#5	2.1250	10 1/4"	17 3/8"	BG892	619.00
2 3/16	#5	2.1875	10 1/4"	17 3/8"	BG893	649.00
2 1/4	#5	2.2500	10 1/4"	17 3/8"	BG894	673.00
2 5/16	#5	2.3125	10 1/4"	17 3/8"	BG895	749.00
2 3/8	#5	2.3750	10 1/4"	17 3/8"	BG896	746.00
2 7/16	#5	2.4375	11 1/4"	18 3/4"	BG897	945.00
2 1/2	#5	2.5000	11 1/4"	18 3/4"	BG898	983.00
2 9/16	#5	2.5625	11 7/8"	19 1/2"	BG899	1066.00
2 5/8	#5	2.6250	11 7/8"	19 1/2"	BG900	1186.00
2 11/16	#5	2.6875	12 3/4"	20 3/8"	BG901	1225.00
2 3/4	#5	2.7500	12 3/4"	20 3/8"	BG902	1265.00
2 13/16	#5	2.8125	13 3/8"	21 1/8"	BG903	1437.00
2 7/8	#5	2.8750	13 3/8"	21 1/8"	BG904	1513.00
2 15/16	#5	2.9375	14"	21 3/4"	BG905	1597.00
3	#5	3.0000	14"	21 3/4"	BG906	1605.00

Note: Metric sizes available

MORSE TAPER REDUCING SLEEVES

Applications:

Used to adapt Morse Taper Shank tools to larger or smaller holders



OIL TOUGHENED

Inside Hole	Outside Taper	Model No.	Price /Each
0 MTS	1 MTS	BH495	29.40
1 MTS	2 MTS	BH496	15.60
1 MTS	3 MTS	BH497	22.70
1 MTS	4 MTS	BH498	30.00
2 MTS	3 MTS	BH499	22.70
2 MTS	4 MTS	BH500	30.00
3 MTS	4 MTS	BH501	30.00
4 MTS	5 MTS	BH503	78.80

HARDENED & GROUND*

Outside Taper	Inside Hole	Model No.	Price /Each
1 MTS	2 MTS	BH504	32.20
1 MTS	3 MTS	BH505	44.10
2 MTS	3 MTS	BH506	44.10
3 MTS	4 MTS	BH507	79.30
4 MTS	5 MTS	BH508	110.00

*Internally & externally

CUTTING TOOLS

ANNULAR CUTTERS

- M2 quality high speed steel
- Right-hand cutting direction
- 3/4" Weldon shank

Applications:

- For general purpose cutting of steel plate, structural steel, steel pipe, etc
- 3 to 5 X faster cutting than conventional drills
- Produces quality burr-free hole in a single pass
- Ideal for magnetic base drill, drill presses and milling machines

CLARKSON  OSBORN



1" DEPTH OF CUT

2" DEPTH OF CUT

3" DEPTH OF CUT

Fractional Size"	Model No.	Price /Each	Fractional Size"	Model No.	Price /Each	Fractional Size"	Model No.	Price /Each
1/2	TFX101	42.40	1/2	TFX129	68.90	3/4	TFX156	185.00
9/16	TFX102	47.30	9/16	TFX130	75.00	13/16	TFX157	195.00
5/8	TFX103	49.20	5/8	TFX131	81.10	7/8	TFX158	204.00
11/16	TFX104	52.90	11/16	TFX132	89.80	15/16	TFX159	211.00
3/4	TFX105	54.00	3/4	TFX133	93.50	1	TFX160	223.00
13/16	TFX106	60.20	13/16	TFX134	103.00	1 1/16	TFX161	241.00
7/8	TFX107	62.70	7/8	TFX135	106.00	1 1/8	TFX162	255.00
15/16	TFX108	67.60	15/16	TFX136	112.00	1 3/16	TFX163	274.00
1	TFX109	70.10	1	TFX137	114.00	1 1/4	TFX164	301.00
1 1/16	TFX110	73.20	1 1/16	TFX138	123.00	1 5/16	TFX165	332.00
1 1/8	TFX111	80.00	1 1/8	TFX139	135.00	1 3/8	TFX166	362.00
1 3/16	TFX112	82.30	1 3/16	TFX140	140.00	1 7/16	TFX167	369.00
1 1/4	TFX113	111.00	1 1/4	TFX141	160.00	1 1/2	TFX168	383.00
1 5/16	TFX114	116.00	1 5/16	TFX142	165.00	1 9/16	TFX169	403.00
1 3/8	TFX115	150.00	1 3/8	TFX143	186.00	1 5/8	TFX170	436.00
1 7/16	TFX116	165.00	1 7/16	TFX144	196.00	1 11/16	TFX171	445.00
1 1/2	TFX117	167.00	1 1/2	TFX145	199.00	1 3/4	TFX172	464.00
1 9/16	TFX118	180.00	1 9/16	TFX146	214.00	1 13/16	TFX173	501.00
1 5/8	TFX119	184.00	1 5/8	TFX147	224.00	1 7/8	TFX174	538.00
1 11/16	TFX120	199.00	1 11/16	TFX148	236.00	1 15/16	TFX175	547.00
1 3/4	TFX121	211.00	1 3/4	TFX149	246.00	2	TFX176	566.00
1 13/16	TFX122	234.00	1 13/16	TFX150	266.00	2 1/16	TFX177	640.00
1 7/8	TFX123	246.00	1 7/8	TFX151	285.00	-	-	-
1 15/16	TFX124	256.00	1 15/16	TFX152	290.00	-	-	-
2	TFX125	271.00	2	TFX153	300.00	-	-	-
2 1/16	TFX126	290.00	2 1/16	TFX154	330.00	-	-	-
2 1/4	TFX127	374.00	2 1/4	TFX155	389.00	-	-	-

Cut pin required TFX178
Price /Each \$8.34

Cut pin required TFX179
Price /Each \$9.72

Cut pin required TFX180
Price /Each \$17.40

COMBINED DRILLS & COUNTERSINKS

- Solid carbide 10% cobalt
- Right-hand cut
- Each drill has 2 hole diameters
- 118° angle point
- 60° countersink angle
- Bright finish

CLARKSON  OSBORN



Applications:

Designed to produce accurate centre holes in components which require machining between centres.

Size No.	Small Dia."	Large Dia."	Overall Length"	Model No.	Price /Each
00	1/32	1/8	1 1/2	BK813	22.80
0	0.025	1/8	1 1/2	BK820	25.30
1	3/64	1/8	1 1/2	BK814	21.40
2	5/64	3/16	1 7/8	BK815	32.70
3	7/64	1/4	2	BK816	37.20
4	1/8	5/16	2 1/8	BK817	50.70
5	3/16	7/16	2 3/4	BK818	75.70
6	7/32	1/2	3"	BK819	109.00

STEP DRILLS

- High speed steel
- Bright finish

Applications:

Stepped cone design provides better control of hole sizes in materials up to 1/8" thick. One step drill does job of up to 13 different size drills. Holes are automatically deburred by cutting edge of next larger size. Ideal for sheet metal and hole-enlarging work.

CLARKSON  OSBORN



Size No.	# of holes	Range from - to	Increments	Model No.	Price /Each
#1	13	1/8 to 1/2	1/32	TJZ795	25.50
#2	6	3/16 to 1/2	1/16	TJZ796	23.90
#3	9	1/4 to 3/4	1/16	TJZ797	42.60
#4	12	3/16 to 7/8	1/16	TJZ798	29.20
#5	10	1/4 to 1 3/8	1/8	TJZ799	50.10

Step drill 3-piece set – contains #1, #2 and #3 step drills in plastic case

Model No. TJZ800 Price/Each \$92.00

STEP DRILLS

- Multiple steps eliminate the need for a tool box of drill bits
- Holds firmly in place with 3 flat sided shank
- SpeedPoint™ tip eliminates skidding and need for centre-punching
- Industrial grade high speed steel
- Easily resharpenable

IRWIN  Industrial Tools



Size	Number of holes	Cutting Ø"	Increments"	Shank Ø	Model No.	Price /Each
#1	13	1/8 to 1/2	1/32	1/4	TQ651	35.10
#2	6	3/16 to 1/2	1/16	1/4	TH080	35.10
#3	9	1/4 to 3/4	1/16	3/8	TH094	63.30
#4	12	3/16 to 7/8	1/16	3/8	TH113	74.80

For Magnetic Base Drills see page 1189



TAP & DRILL SETS

18 PC BLUE WIZARD

- Premium high speed steel
- Metal case

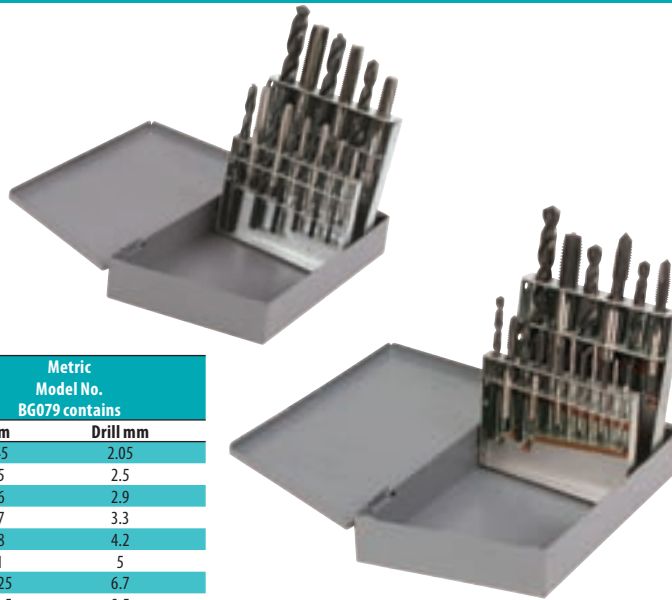

CLARKSON OSBORN

NC (National Coarse) Model No. BG080 contains		NF (National Fine) Model No. BG078 contains		Metric Model No. BG079 contains	
Tap	Drill	Tap	Drill	Tap mm	Drill mm
#6-32	#36	#6-40	#33	2.5 x .45	2.05
#8-32	#29	#8-36	#29	3.0 x .5	2.5
#10-32	#21	#10-32	#21	3.5 x .6	2.9
#12-24	#16	#12-28	#15	4.0 x .7	3.3
1/4-20	#7	1/4-28	#3	5.0 x .8	4.2
5/16-18	F	5/16-24	#1	6.0 x 1	5
3/8-16	5/16	3/8"-24	Q	8.0 x 1.25	6.7
7/16-14	U	7/16	25/64	10.0 x 1.5	8.5
1/2-13	27/64	1/2-20	29/64	12 x 1.75	10
Price/Each \$192.00		Price/Each \$192.00		Price/Each \$222.00	

PIPE TAPS

- High speed steel, ground threads
- Square drive shank
- Right hand cutting direction



CLARKSON OSBORN

WARWICK NPT (NATIONAL PIPE THREAD) TAPS

Applications:

For tapping tapered pipe threads. This is the most common of all pipe tap styles. The tapered thread form creates a pressure-tight joint when used with a sealant.

NPT Size	L2 "	L1 "	L3 "	A "	Flutes	Model No.	Price /Each
1/16-27	11/16	2 1/8	3/8	0.234	3	BD944	26.10
1/8-27	3/4	2 1/8	3/8	0.328	3	QD610	26.10
1/4-18	1 1/16	2 7/16	7/16	0.421	5	QD611	31.90
3/8-18	1 1/16	2 9/16	1/2	0.531	5	QD612	40.60
1/2-14	1 3/8	3 1/8	5/8	0.515	5	BD946	60.90
3/4-14	1 3/8	3 1/4	11/16	0.679	5	BD947	89.90
1-11.5	1 3/4	3 3/4	13/16	0.843	5	BD948	135.00
1 1/4-11.5	1 3/4	4	15/16	0.984	7	BD949	213.00
1 1/2-11.5	1 3/4	4 1/4	1	1.125	7	BD950	255.00
2-11.5	1 3/4	4 1/2	1 1/8	1.406	7	BD951	319.00

WARWICK NPTF (DRYSEAL NATIONAL PIPE THREAD) TAPS

HSS taper pipe taps are designed for tapping ferrous and non-ferrous fittings used to connect pipes carrying fluids or gases and other places where very tight fits are needed. NPTF taper thread pipe taps do not require sealants. Dryseal is attained by metal to metal contact.

NPTF Size	L2 "	L1 "	L3 "	A "	Flutes	Model No.	Price /Each
1/16-27	11/16	2 1/8	3/8	0.234	3	BD961	63.70
1/8-27	3/4	2 1/8	3/8	0.328	3	BD962	63.00
1/4-18	1 1/16	2 7/16	7/16	0.421	5	BD963	67.30
3/8-18	1 1/16	2 9/16	1/2	0.531	5	BD964	99.40
1/2-14	1 3/8	3 1/8	5/8	0.515	5	BD965	116.00
3/4-14	1 3/8	3 1/4	11/16	0.679	5	BD966	146.00
1-11.5	1 3/4	3 3/4	13/16	0.843	5	BD967	255.00
1 1/4-11.5	1 3/4	4	15/16	0.984	7	BD968	400.00

WARWICK NPTI (INTERRUPTED NATIONAL PIPE THREAD) TAPS

Application:

HSS interrupted thread pipe taps are designed for tapping soft or tough stringy metals that tend to load threads with chips. Interrupted thread pipe taps start with a few full threads and then have every other thread removed along the thread helix to provide more chip space, better lubrication, and to reduce drag.

NPTI Size	L2 "	L1 "	L3 "	A "	Flutes	Model No.	Price /Each
1/8-27	3/4	2 1/8	3/8	0.328	3	BD952	58.00
1/4-18	1 1/16	2 7/16	7/16	0.421	5	BD953	63.80
3/8-18	1 1/16	2 9/16	1/2	0.531	5	BD954	81.20
1/2-14	1 3/8	3 1/8	5/8	0.515	5	BD955	129.00
3/4-14	1 3/8	3 1/4	11/16	0.679	5	BD956	142.00
1-11.5	1 3/4	3 3/4	13/16	0.843	5	BD957	281.00
1 1/4-11.5	1 3/4	4	15/16	0.984	7	BD958	377.00
1 1/2-11.5	1 3/4	4 1/4	1	1.125	7	BD959	464.00
2-11.5	1 3/4	4 1/2	1 1/8	1.406	7	BD960	667.00

WARWICK NPTS (STRAIGHT NATIONAL PIPE THREAD) TAPS

Application:

HSS straight thread pipe taps (NPTS) are designed for tapping holes or couplings for low pressure work that will adjust at assembly to the taper of external threads. A sealant must be used to secure a pressure-tight joint.

NPTS Size	L2 "	L1 "	L3 "	A "	Flutes	Model No.	Price /Each
1/8-27	3/4	2 1/8	3/8	0.328	4	BD969	41.30
1/4-18	1 1/16	2 7/16	7/16	0.421	4	BD970	57.20
3/8-18	1 1/16	2 9/16	1/2	0.531	4	BD971	87.40
1/2-14	1 3/8	3 1/8	5/8	0.515	4	BD972	120.00
3/4-14	1 3/8	3 1/4	11/16	0.679	4	BD973	167.00
1-11.5	1 3/4	3 3/4	13/16	0.843	6	BD974	315.00

CUTTING TOOLS



CLARKSON  **OSBORN**

HAND TAPS

- High speed steel ground thread
- Square drive shank
- Right hand cutting direction, straight flute
- Available in taper, plug, bottoming and sets
- Bright finish

Applications:

Taps cut a thread on the inside surface of a hole, creating a female surface which functions like a nut. Well suited for a variety of ferrous & non-ferrous materials.



Taper

Used in through-holes and for starting threads.

Used in through-holes and in blind holes with space at the bottom for chip accumulation.

Used in blind holes where threads must come as close to the hole's bottom as possible

Plug

Bottoming

MACHINE SCREW SIZES - NC NATIONAL COARSE NF NATIONAL FINE

Fractional Size	Taper Model No.	Plug Model No.	Bottoming Model No.	Price /Each	L2 "	L1 "	L3 "	A"	Flutes	Set of 3 taps		
										Model No.	Price /Each	
0-80	NF	BL964	BL965	BL966	22.90	3/8	1 5/8	3/16	0.110	3	BL963	68.60
1-64	NC	BL968	BL969	BL970	22.20	7/16	1 11/16	3/16	0.110	2	BL967	66.50
1-72	NF	BM005	BM006	BM007	22.20	7/16	1 11/16	3/16	0.110	3	BM004	66.50
2-56	NC	BL972	BL973	BL974	18.80	1/2	1 3/4	3/16	0.110	3	BL971	56.60
2-64	NF	BM009	BM010	BM011	18.80	1/2	1 3/4	3/16	0.110	3	BM008	56.60
3-48	NC	BL976	BL977	BL978	13.90	9/16	1 13/16	3/16	0.110	3	BL975	41.70
3-56	NF	BM013	BM014	BM015	13.90	9/16	1 13/16	3/16	0.110	3	BM012	41.70
4-40	NC	BL980	BL981	BL982	11.50	5/8	1 7/8	3/16	0.110	3	BL979	34.40
4-48	NF	BM017	BM018	BM019	11.50	5/8	1 7/8	3/16	0.110	3	BM016	34.40
5-40	NC	BL984	BL985	BL986	11.50	11/16	1 15/16	3/16	0.110	3	BL983	34.40
5-44	NF	BM021	BM022	BM023	11.50	11/16	1 15/16	3/16	0.110	3	BM020	34.40
6-32	NC	BL988	BL989	BL990	8.72	11/16	2	3/16	0.110	3	BL987	26.10
6-40	NF	BM025	BM026	BM027	8.72	11/16	2	3/16	0.110	3	BM024	26.10
8-32	NC	BL992	BL993	BL994	8.72	3/4	2 1/8	1/4	0.131	4	BL991	26.10
8-36	NF	BM029	BM030	BM031	8.72	3/4	2 1/8	1/4	0.131	4	BM028	26.10
10-24	NC	BL996	BL997	BL998	9.44	7/8	2 3/8	1/4	0.152	4	BL995	28.30
10-32	NF	BM033	BM034	BM035	9.44	7/8	2 3/8	1/4	0.152	4	BM032	28.30
12-24	NC	BM001	BM002	BM003	9.74	15/16	2 3/8	9/32	0.165	4	BL999	29.20
12-28	NF	BM037	BM038	BM039	9.74	15/16	2 3/8	9/32	0.165	4	BM036	29.20

FRACTIONAL SIZES - NC NATIONAL COARSE NF NATIONAL FINE

Fractional Size	Taper Model No.	Plug Model No.	Bottoming Model No.	Price /Each	L2 "	L1 "	L3 "	A"	Flutes	Set of all 3 taps		
										Model No.	Price /Each	
1/4-20	NC	BL843	BL844	BL845	9.28	1	2 1/2	5/16	0.191	4	BL842	27.80
1/4-28	NF	BL905	BL906	BL907	9.28	1	2 1/2	5/16	0.191	4	BL904	27.80
5/1-18	NC	BL847	BL848	BL849	11.50	1 1/8	2 23/32	3/8	0.238	4	QE252	34.60
5/16-24	NF	BL909	BL910	BL911	11.50	1 1/8	2 23/32	3/8	0.238	4	BL908	34.60
3/8-16	NC	BL851	BL852	BL853	13.00	1 1/4	2 15/16	7/16	0.286	4	BL850	39.10
3/8-24	NF	BL912	BL913	BL914	13.00	1 1/4	2 15/16	7/16	0.286	4	VE890	39.10
7/16-14	NC	BL855	BL856	BL857	22.50	1 7/16	3 5/32	13/32	0.242	4	BL854	67.50
7/16-20	NF	BL916	BL917	BL918	22.50	1 7/16	3 5/32	13/32	0.242	4	BL915	67.50
1/2-13	NC	BL859	BL860	BL861	23.20	1 21/32	3 3/8	7/16	0.275	4	BL858	69.60
1/2-20	NF	BL920	BL921	BL922	23.20	1 21/32	3 3/8	7/16	0.275	4	BL919	69.60
9/16-12	NC	BL863	BL864	BL865	38.80	1 21/32	3 19/32	1/2	0.322	4	BL862	117.00
9/16-18	NF	BL924	BL925	BL926	38.80	1 21/32	3 19/32	1/2	0.322	4	BL923	117.00
5/8-11	NC	QE253	BL867	BL868	47.10	1 13/16	3 13/16	9/16	0.360	4	BL866	141.00
5/8-18	NF	BL928	BL929	BL930	47.10	1 13/16	3 13/16	9/16	0.360	4	BL927	141.00
3/4-10	NC	VE860	BL870	BL871	65.30	2	4 1/4	11/16	0.442	4	BL869	196.00
3/4-16	NF	BL932	BL933	BL934	65.30	2	4 1/4	11/16	0.442	4	BL931	196.00
7/8-9	NC	BL873	BL874	BL875	90.70	2 7/32	4 11/16	3/4	0.523	4	BL872	272.00
7/8-14	NF	BL936	BL937	BL938	90.70	2 7/32	4 11/16	3/4	0.523	4	BL935	272.00
1-8	NC	BL877	BL878	BL879	121.00	2 1/2	5 1/8	13/16	0.6000	4	BL876	363.00
1-12	NF	BL940	BL941	BL942	121.00	2 1/2	5 1/8	13/16	0.6000	4	BL939	363.00
1-14	NS	BL960	BL961	BL962	121.00	2 1/2	5 1/8	13/16	0.6000	4	BL959	363.00
1 1/8-7	NC	QE254	BL882	BL883	157.00	2 9/16	5 7/16	7/8	0.6720	4	BL880	472.00
1 1/8-12	NF	BL944	BL945	BL946	157.00	2 9/16	5 7/16	7/8	0.6720	4	BL943	472.00
1 1/4-7	NC	BL885	BL886	BL887	209.00	2 9/16	5 3/4	1	0.7660	4	BL884	626.00
1 1/4-12	NF	BL948	BL949	BL950	209.00	2 9/16	5 3/4	1	0.7660	4	BL947	626.00
1 3/8-6	NC	BL889	BL890	BL891	263.00	3	6 1/16	1 1/16	0.8310	4	BL888	787.00
1 3/8-12	NF	BL952	BL953	BL954	263.00	3	6 1/16	1 1/16	0.8310	4	BL951	787.00
1 1/2-6	NC	BL893	BL894	BL895	303.00	3	6 3/8	1 1/8	0.9250	4	BL892	909.00
1 1/2-12	NE	BL956	BL957	BL958	303.00	3	6 3/8	1 1/8	0.9250	4	BL955	909.00
1 3/4-5	NC	BL897	BL898	BL899	447.00	3 3/16	7	1 1/4	1.0720	6	BL896	1340.00
2-4.5	NC	BL901	BL902	BL903	496.00	3 9/16	7 5/8	1 3/8	1.2330	6	BL900	1488.00

HAND TAPS (CONT'D)

METRIC COARSE SIZES

Size	Taper Model No.	Plug Model No.	Bottoming Model No.	Price /Each	L2 mm	L1 mm	L3 mm	A mm	Flutes	Set of 3 taps	
										Model No.	Price /Each
M1.6 X 0.35	BM175	BM176	BM177	51.40	8.0	41.0	4.0	2.00	3	BM174	154.00
M2 X 0.4	BM185	BM186	BM187	20.50	8.0	41.0	4.0	2.00	3	BM184	61.40
M2.2 X 0.45	BM182	BM183	TBM075	21.20	9.5	44.5	5.0	2.24	3	BM181	63.60
M2.5 X 0.45	BM189	BM190	BM191	14.80	9.5	44.5	5.0	2.24	3	BM188	44.40
M3 X 0.5	BM193	BM194	BM195	12.00	15.0	48.0	5.0	2.50	3	BM192	36.10
M3.5 X 0.6	BM197	BM198	BM199	9.44	17.0	50.0	5.0	2.80	3	BM196	28.30
M4 X 0.7	BM201	BM202	BM203	9.44	17.0	53.0	6.0	3.15	3	BM200	28.30
M4.5 X 0.75	BM205	BM206	BM207	9.44	17.0	53.0	6.0	3.55	3	BM204	28.30
M5 X 0.8	BM209	BM210	BM211	10.40	16.0	58.0	7.0	4.00	3	BM208	31.30
M6 X 1	BM213	BM214	BM215	10.90	19.0	66.0	8.0	5.00	3	BM212	32.70
M7 X 1	BM217	BM218	BM219	11.60	19.0	66.0	8.0	5.60	4	BM216	34.80
M8 X 1.25	BM221	BM222	BM223	11.60	22.0	72.0	9.0	6.30	4	BM220	34.80
M9 X 1.25	BM225	BM226	BM227	14.50	22.0	72.0	10.0	7.10	4	BM224	43.50
M10 X 1.5	BM229	BM230	BM231	21.80	24.0	80.0	11.0	8.00	4	BM228	65.30
M11 X 1.5	BM233	BM234	BM235	21.80	25.0	85.0	9.0	6.30	4	BM232	65.30
M12 X 1.75	BM237	BM238	BM239	24.60	19.0	89.0	10.0	7.10	4	BM236	74.00
M14 X 2	BM241	BM242	BM243	37.70	30.0	95.0	12.0	9.00	4	BM240	113.00
M16 X 2	BM245	BM246	BM247	46.40	32.0	102.0	13.0	10.00	4	BM244	139.00
M18 X 2.5	BM249	BM250	BM251	63.80	37.0	112.0	14.0	11.20	4	BM248	191.00
M20 X 2.5	BM253	BM254	BM255	87.70	37.0	112.0	14.0	11.20	4	BM252	263.00
M22 X 2.5	BM257	BM258	BM259	102.00	38.0	118.0	16.0	12.50	4	BM256	307.00
M24 X 3	BM261	BM262	BM263	117.00	45.0	130.0	18.0	14.00	4	BM260	352.00
M27 X 3	BM265	BM266	BM267	158.00	45.0	135.0	20.0	16.00	4	BM264	474.00
M30 X 3.5	BM269	BM270	BM271	170.00	48.0	138.0	20.0	16.00	4	BM268	511.00
M33 X 3.5	BM273	BM274	BM275	230.00	51.0	151.0	22.0	18.00	4	BM272	689.00
M36 X 4	BM277	BM278	BM279	256.00	57.0	162.0	24.0	20.00	4	BM276	767.00
M39 X 4	BM280	BM281	BM282	309.00	60.0	170.0	26.0	22.40	4	TBM083	927.00
M42 X 4.5	BM284	BM285	BM286	359.00	60.0	170.0	26.0	22.40	6	BM283	1077.00
M45 X 4.5	TBM067	BM287	BM288	483.00	67.0	187.0	28.0	25.00	6	TBM084	1450.00
M48 X 5	TBM068	BM289	BM290	538.00	67.0	187.0	28.0	25.00	6	TBM085	1615.00
M52 X 5	TBM069	BM291	BM292	677.00	70.0	200.0	31.0	28.00	6	TBM086	2030.00
M56 X 5.5	TBM070	BM293	BM294	918.00	70.0	200.0	31.0	28.00	6	TBM087	2755.00

METRIC FINE SIZES

Size	Taper Model No.	Plug Model No.	Bottoming Model No.	Price /Each	L2 mm	L1 mm	L3 mm	A mm	Flutes	Set of 3 taps	
										Model No.	Price/Each
MF3 X 0.35	BM296	BM297	BM298	24.90	15.0	48.0	5.0	2.50	3	BM295	74.60
MF3.5 X 0.35	BM299	BM300	BM301	25.90	17.0	50.0	5.0	2.80	3	TBM088	77.70
MF4 X 0.5	BM303	BM304	BM305	24.90	17.0	53.0	6.0	3.15	3	BM302	74.60
MF4.5 X 0.5	BM307	BM308	BM309	27.60	17.0	53.0	6.0	3.55	3	BM306	82.90
MF5 X 0.5	BM311	BM312	BM313	24.90	16.0	58.0	7.0	4.00	3	BM310	74.60
MF6 X 0.5	BM315	BM316	BM317	60.70	19.0	66.0	8.0	5.00	3	BM314	190.00
MF6 X 0.75	BM319	BM320	BM321	24.90	19.0	66.0	8.0	5.00	3	BM318	74.60
MF7 X 0.75	BM323	BM324	BM325	27.60	19.0	66.0	8.0	5.60	4	BM322	82.90
MF8 X 0.5	BM328	BM329	BM330	66.00	19.0	69.0	9.0	6.30	4	BM327	198.00
MF8 X 0.75	BM332	BM333	BM334	30.40	22.0	72.0	9.0	6.30	4	BM331	91.20
MF8 X 1	BM335	BM336	BM337	25.90	22.0	72.0	9.0	6.30	4	BM326	77.70
MF9 X 1	BM338	BM339	BM340	60.80	22.0	72.0	10.0	7.10	4	BM341	182.00
MF10 X 0.75	BM345	BM346	BM347	60.80	24.0	80.0	11.0	8.00	4	BM344	182.00
MF10 X 1	BM348	BM349	BM350	37.60	24.0	80.0	11.0	8.00	4	BM342	113.00
MF10 X 1.25	BM351	BM352	BM353	36.30	24.0	80.0	11.0	8.00	4	BM343	109.00
MF11 X 0.75	BM355	BM356	BM357	75.00	22.0	82.0	9.0	6.30	4	BM354	225.00
MF11 X 1	BM359	BM360	BM361	75.00	22.0	82.0	9.0	6.30	4	BM358	225.00
MF12 X 1	BM363	BM364	BM365	72.60	29.0	89.0	10.0	7.10	4	BM362	218.00
MF12 X 1.25	BM367	BM368	BM369	47.70	29.0	89.0	10.0	7.10	4	BM366	143.00
MF12 X 1.5	BM371	BM372	BM373	47.70	29.0	89.0	10.0	7.10	4	BM370	143.00
MF14 X 1	BM375	BM376	BM377	80.50	30.0	95.0	12.0	9.00	4	BM374	242.00
MF14 X 1.25	BM379	BM380	BM381	54.20	30.0	95.0	12.0	9.00	4	BM378	163.00
MF14 X 1.5	BM383	BM384	BM385	52.50	30.0	95.0	12.0	9.00	4	BM382	157.00
MF16 X 1	BM387	BM388	BM389	87.40	32.0	102.0	13.0	10.00	4	BM386	262.00
MF16 X 1.5	BM391	BM392	BM393	59.10	32.0	102.0	13.0	10.00	4	BM390	177.00
MF18.0 X 1	BM395	BM396	BM397	112.00	37.0	112.0	14.0	11.20	4	BM394	337.00
MF18 X 1.5	BM399	BM400	BM401	81.80	37.0	112.0	14.0	11.20	4	BM398	246.00
MF18 X 2	BM403	BM404	BM405	112.00	37.0	112.0	14.0	11.20	4	BM402	337.00
MF20 X 1	BM407	BM408	BM409	128.00	37.0	112.0	14.0	11.20	4	BM406	385.00
MF20 X 1.5	BM411	BM412	BM413	99.40	37.0	112.0	14.0	11.20	4	BM410	298.00
MF20 X 2	BM415	BM416	BM417	128.00	37.0	112.0	14.0	11.20	4	BM414	385.00
MF22 X 1.5	BM419	BM420	BM421	112.00	38.0	118.0	16.0	12.50	4	BM418	337.00
MF22 X 2	BM423	BM424	BM425	124.00	38.0	118.0	16.0	12.50	4	BM422	373.00
MF24 X 1.5	BM427	BM428	BM429	163.00	45.0	130.0	18.0	14.00	4	BM426	488.00
MF24 X 2	BM431	BM432	BM433	141.00	45.0	130.0	18.0	14.00	4	BM430	422.00
MF25 X 1.5	BM435	BM436	BM437	135.00	35.0	120.0	18.0	14.00	4	BM434	405.00
MF27 X 2	BM439	BM440	BM441	207.00	37.0	127.0	20.0	16.00	4	BM438	622.00
MF30 X 1.5	BM443	BM444	BM445	268.00	37.0	127.0	20.0	16.00	4	BM442	803.00
MF30 X 2	BM447	BM448	BM449	230.00	37.0	127.0	20.0	16.00	4	BM446	689.00
MF32 X 1.5	TBM076	BM451	TBM079	268.00	37.0	137.0	22.0	18.00	4	BM450	803.00
MF40 X 1.5	TBM077	TBM078	TBM080	425.00	39.0	149.0	26.0	22.40	4	TBM089	1274.00

CUTTING TOOLS

WIZARD SPIRAL POINT MACHINE TAPS - NC & NF

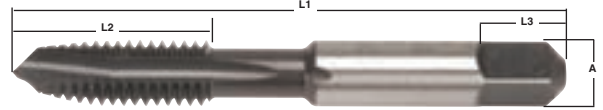

CLARKSON  OSBORN

Size	L2"	L1"	L3"	A"	Flutes	Blue Wizard Model No.	Mfg. No.	Price /Each	White Wizard Model No.	Mfg. No.	Price /Each	Gold Wizard Model No.	Mfg. No.	Price /Each	
0-80	NF	3/8	1 5/8	3/16	0.110	2	BF370	CT72100	32.40	-	-	TBM048	CT79100	43.20	
1-64	NC	7/16	1 11/16	3/16	0.110	2	BF367	CT72001	32.40	-	-	TBM049	CT79001	43.20	
1-72	NF	7/16	1 11/16	3/16	0.110	2	BF371	CT72101	32.40	-	-	TBM050	CT79101	43.20	
2-56	NC	1/2	1 3/4	3/16	0.110	2	BF368	CT72002	19.10	-	-	BF544	CT79002	29.40	
2-64	NF	1/2	1 3/4	3/16	0.110	2	BF372	CT72102	19.10	-	-	TBM051	CT79102	29.40	
3-48	NC	9/16	1 13/16	3/16	0.110	2	BF369	CT72003	19.10	-	-	TBM052	CT79003	29.40	
3-56	NF	9/16	1 13/16	3/16	0.110	2	BF373	CT72103	19.10	-	-	TBM053	CT79103	29.40	
4-40	NC	5/8	1 7/8	3/16	0.110	2	QD614	CT72004	17.20	BF390	CT73004	20.60	TBM054	CT79004	27.40
4-48	NF	5/8	1 7/8	3/16	0.110	2	BF374	CT72104	17.20	BF400	CT73104	20.60	BF550	CT79104	27.40
5-40	NC	11/16	1 15/16	3/16	0.110	2	QD615	CT72005	17.20	BF391	CT73005	20.60	BF545	CT79005	27.40
5-44	NF	11/16	1 15/16	3/16	0.110	2	BF375	CT72105	17.20	BF401	CT73105	20.60	BF551	CT79105	27.40
6-32	NC	11/16	2	3/16	0.110	2	QD616	CT72006	11.30	BF392	CT73006	13.60	BF546	CT79006	21.30
6-40	NF	11/16	2	3/16	0.110	2	BF376	CT72106	11.30	BF402	CT73106	13.60	TBM055	CT79106	21.30
8-32	NC	3/4	2 1/8	1/4	0.131	2	QD617	CT72008	11.30	BF393	CT73008	13.60	BF547	CT79008	21.30
8-36	NF	3/4	2 1/8	1/4	0.131	2	BF377	CT72108	11.30	BF403	CT73108	13.60	TBM056	CT79108	21.30
10-24	NC	11/16	2 3/8	1/4	0.152	2	QD618	CT72010	11.30	BF394	CT73010	13.60	BF548	CT79010	21.30
10-32	NF	11/16	2 3/8	1/4	0.152	2	-	-	-	BF404	CT73110	13.60	BF552	CT79110	21.30
12-24	NC	11/16	2 3/8	9/32	0.165	2	QD619	CT72012	15.00	BF395	CT73012	18.00	BF549	CT79012	25.10
12-28	NF	11/16	2 3/8	9/32	0.165	2	QD621	CT72120	15.00	BF405	CT73120	18.00	TBM057	CT79120	25.10
1/4-20	NC	13/16	2 1/2	5/16	0.191	2	QD622	CT72404	12.20	BF406	CT73404	14.60	BF553	CT79404	22.20
1/4-28	NF	13/16	2 1/2	5/16	0.191	2	QD631	CT72504	12.20	BF416	CT73504	14.60	BF561	CT79504	22.20
5/16-18	NC	7/8	2 23/32	3/8	0.238	3	QD623	CT72405	13.20	BF407	CT73405	15.80	BF554	CT79405	29.10
5/16-24	NF	7/8	2 23/32	3/8	0.238	3	QD632	CT72505	13.20	BF417	CT73505	15.80	BF562	CT79505	29.10
3/8-16	NC	1	2 15/16	7/16	0.286	3	QD624	CT72406	17.80	BF408	CT73406	21.30	BF555	CT79406	33.70
3/8-24	NF	1	2 15/16	7/16	0.286	3	QD633	CT72506	17.80	BF418	CT73506	21.30	BF563	CT79506	33.70
7/16-14	NC	1 1/16	3 5/32	13/32	0.242	3	QD625	CT72407	23.80	BF409	CT73407	28.60	BF556	CT79407	44.00
7/16-20	NF	1 1/16	3 5/32	13/32	0.242	3	QD634	CT72507	23.80	BF419	CT73507	28.60	BF564	CT79507	44.00
1/2-13	NC	1 3/16	3 3/8	7/16	0.275	3	QD626	CT72408	26.10	BF410	CT73408	31.40	BF557	CT79408	46.30
1/2-20	NF	1 3/16	3 3/8	7/16	0.275	3	QD635	CT72508	26.10	BF420	CT73508	31.40	BF565	CT79508	46.30
9/16-12	NC	1 3/16	3 19/32	1/2	0.322	3	-	-	-	BF411	CT73409	54.70	BF558	CT79409	66.80
9/16-18	NF	1 3/16	3 19/32	1/2	0.322	3	QR181	CT72509	45.60	BF421	CT73509	54.70	BF566	CT79509	66.80
5/8-11	NC	1 3/8	3 13/16	9/16	0.360	3	QD627	CT72410	45.60	BF412	CT73410	54.70	BF559	CT79410	80.60
5/8-18	NF	1 3/8	3 13/16	9/16	0.360	3	QD636	CT72510	45.60	BF422	CT73510	54.70	TBM058	CT79510	80.60
3/4-10	NC	1 7/16	4 1/4	11/16	0.442	3	QD628	CT72412	66.00	BF413	CT73412	79.30	TBM059	CT79412	114.00
3/4-16	NF	1 7/16	4 1/4	11/16	0.442	3	QD637	CT72512	66.00	BF423	CT73512	79.30	BF567	CT79512	114.00
7/8-9	NC	1 5/8	4 11/16	3/4	0.523	3	QD629	CT72414	87.40	BF414	CT73414	105.00	TBM060	CT79414	139.00
7/8-14	NF	1 5/8	4 11/16	3/4	0.523	3	QR186	CT72514	87.40	BF424	CT73514	105.00	TBM061	CT79514	139.00
1-8	NC	1 3/4	5 1/8	13/16	0.600	4	QD630	CT72416	112.00	BF415	CT73416	134.00	BF560	CT79416	164.00
1-12	NF	1 3/4	5 1/8	13/16	0.600	4	QR161	CT72516	112.00	BF425	CT73516	134.00	TBM062	CT79516	164.00

WIZARD SPIRAL POINT MACHINE TAPS - METRIC

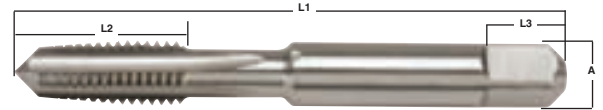

CLARKSON  OSBORN

Size	L2 mm	L1 mm	L3 mm	A mm	Flutes	Blue Wizard Model No.	Mfg. No.	Price /Each	Gold Wizard Model No.	Mfg. No.	Price /Each
M2.0 x 0.40	8.0	41.0	4.0	2.00	2	BF350	CT71020	24.90	TBM035	CT78020	35.60
M2.5 x 0.45	9.5	44.5	5.0	2.24	2	BF351	CT71025	20.60	TBM036	CT78025	31.20
M3.0 x 0.50	15.0	48.0	5.0	2.50	2	QR162	CT71030	16.10	BF535	CT78030	26.40
M3.5 x 0.60	17.0	50.0	5.0	2.80	2	QR163	CT71035	16.10	TBM037	CT78035	26.40
M4.0 x 0.70	17.0	53.0	6.0	3.15	2	QR164	CT71040	13.30	BF536	CT78040	23.50
M4.5 x 0.75	17.0	53.0	6.0	3.55	2	BF352	CT71045	17.90	TBM038	CT78045	28.30
M5.0 x 0.80	16.0	58.0	7.0	4.00	3	QR165	CT71050	14.90	BF537	CT78050	25.20
M6.0 x 1.00	19.0	66.0	8.0	5.00	3	QR166	CT71060	15.30	BF538	CT78060	25.60
M7.0 x 1.00	19.0	66.0	8.0	5.60	3	BF353	CT71070	19.80	TBM039	CT78070	36.90
M8.0 x 1.25	22.0	72.0	9.0	6.30	3	QR167	CT71080	16.70	BF539	CT78080	33.60
M10.0 x 1.50	24.0	80.0	11.0	8.00	3	QR168	CT71100	22.90	BF540	CT78100	44.00
M12.0 x 1.75	29.0	89.0	10.0	7.10	3	QR101	CT71120	36.50	BF541	CT78120	58.20
M14.0 x 2.00	30.0	95.0	12.0	9.00	3	QR172	CT71140	47.10	BF542	CT78140	70.20
M16.0 x 2.00	32.0	102.0	13.0	10.00	3	QR112	CT71160	58.70	BF543	CT78160	96.20
M18.0 x 2.50	37.0	112.0	14.0	11.20	3	BF354	CT71180	79.30	TBM040	CT78180	118.00
M20.0 x 2.50	37.0	112.0	14.0	11.20	3	QR160	CT71200	103.00	TBM041	CT78200	155.00
M22.0 x 2.50	38.0	118.0	16.0	12.50	3	BF355	CT71220	120.00	TBM042	CT78220	177.00
M24.0 x 3.00	45.0	130.0	18.0	14.00	3	QR183	CT71240	135.00	TBM043	CT78240	193.00

EXTENSION HAND TAPS

- High speed steel, ground threads
- Square drive shank
- Right hand cutting direction
- Plug style only

Application:

Designed for deep hole tapping where the work requires an undercut shank to follow through hole

MACHINE SCRW SIZES - NATIONAL COARSE NC & NATIONAL FINE NF

NF & NC Size	L2"	L1"	A"	Flutes	Model No.	Price /Each
6-32 NC	11/16	6	0.141	3	BM040	61.90
8-32 NC	3/4	6	0.168	4	BM041	61.90
10-24 NC	7/8	6	0.194	4	BM042	59.90
10-32 NF	7/8	6	0.194	4	BM051	59.90

FRACTIONAL - NATIONAL FINE NF

National Fine Size	L2"	L1"	A"	Flutes	Model No.	Price /Each
1/4-28 NF	1	6	0.255	4	BM052	52.30
5/16-24 NF	1 1/8	6	0.318	4	TBL997	58.20
3/8-24 NF	1 1/4	6	0.381	4	BM053	63.00
7/16-20 NF	1 7/16	6	0.323	4	TBM002	131.00
1/2-20 NF	1 21/32	6	0.367	4	BM054	80.40
9/16-18 NF	1 21/32	6	0.429	4	TBM004	184.00
5/8-18 NF	1 13/16	6	0.480	4	TBM005	196.00

BAR TYPE TAP & REAMER WRENCHES

- Best suited for smaller diameter hand taps & reamers
- Holds round or square drive shanks



CLARKSON OSBORN

Model No.	Sizes	Price/Each
BM610	1/16"/M2 to 1/4"/M6	44.90
BM611	1/8"/M3 to 1/2"/M12	69.70

ADJUSTABLE TAP WRENCHES

- Rugged construction
- Well balanced
- Holds round or square drive shanks



CLARKSON OSBORN

Model No.	Sizes	Price/Each
BM612	1/8"/M3 to 1/2"/M12	75.40
BM613	7/32"/M6 to 3/4"/M20	85.60
BM614	7/16"/M12 to 1"/M24	113.00
BM615	3/4"/M18 to 1 1/2"/M42	250.00
BM616	1"/M24 to 2 1/2"/M50	398.00



FRACTIONAL - NATIONAL COARSE NC

National Coarse Size	L2"	L1"	A"	Flutes	Model No.	Price /Each
1/4-20 NC	1	6	0.255	4	BM043	52.30
1/4-20 NC	1	6	0.185	4	BM062	83.20
1/4-20 NC	1	8	0.255	4	BM055	64.10
5/16-18 NC	1 1/8	6	0.318	4	BM044	55.70
5/16-18 NC	1 1/8	6	0.420	4	BM063	85.50
5/16-18 NC	1 1/8	8	0.318	4	BM056	63.90
3/8-16 NC	1 1/4	6	0.381	4	BM045	60.10
3/8-16 NC	1 1/4	8	0.381	4	BM057	78.70
3/8-16 NC	1 1/4	6	0.275	4	TBL998	93.70
3/8-16 NC	1 1/4	10	0.381	4	TBL999	173.00
7/16-14 NC	1 7/16	6	0.323	4	BM046	131.00
1/2-13 NC	1 21/32	6	0.367	4	BM047	80.40
9/16-12 NC	1 21/32	6	0.429	4	BM048	184.00
5/8-11 NC	1 13/16	6	0.480	4	BM049	196.00
5/8-11 NC	1 13/16	8	0.480	4	BM058	234.00
3/4-10 NC	2	6	0.590	4	BM050	230.00
3/4-10 NC	2	8	0.590	4	BM059	260.00
3/4-10 NC	2	10	0.590	4	TBM006	305.00
7/8-9 NC	2 7/32	8	0.697	4	BM060	268.00
1-8 NC	2 1/2	8	0.800	4	BM061	326.00
1-8 NC	2 1/2	10	0.800	4	TBM007	394.00

T-TYPE TAP WRENCHES

- Knurled cap and chuck sleeve
- Heat-treated jaws
- T-handle
- Available in 4" and 8" body lengths



4" BODY LENGTH

CLARKSON OSBORN

Model No.	Sizes	Price/Each
QR060	1/16"/M1 to 1/4"/M6	64.40
QR051	1/4"/M6 to 1/2"/M12	64.40

8" BODY LENGTH

Model No.	Sizes	Price/Each
BM617	1/16"/M1 to 1/4"/M6	71.80
BM618	1/4"/M6 to 1/2"/M12	79.90

DIE STOCKS

- For round split dies
- Knurled handle



CLARKSON OSBORN

Die Ø"	Overall Length"	Model No.	Price /Each
13/16	6 1/2	BM619	23.20
1	9	BM620	40.60
1 15/16	11	BM623	49.30
1 1/2	13 3/4	BM621	49.30
2	21 5/8	BM622	68.20
2 1/4	24	BM625	148.00
3	31	BM624	236.00

CUTTING TOOLS

PIPE DIES

- Industrial duty
- High speed steel
- Right hand cut



NATIONAL PIPE THREAD - NPT

NPT Size	∅"	Thickness"	Model No.	Price /Each
1/8-27	1	3/8	BM149	38.00
1/8-27	1 5/16	7/16	TBL912	198.00
1/8-27	1 1/2	1/2	BM150	61.20
1/4-18	1 5/16	7/16	TBL913	198.00
1/4-18	1 1/2	1/2	QE257	61.20
1/4-18	2	5/8	BM153	289.00
3/8-18	1 1/2	1/2	BM152	61.20
3/8-18	2	5/8	BM154	289.00
1/2-14	2	5/8	BM155	108.00
3/4-14	2	5/8	BM156	108.00
1-11.5	3	7/8	BM157	152.00
1 1/4-11.5	3	7/8	BM158	662.00
1 1/2-11.5	4	1	BM159	2069.00
2-11.5	4	1	BM160	2069.00

BRITISH STANDARD PIPE THREAD - BSPT

BSPT Size	∅"	Thickness"	Model No.	Price /Each
1/2-14	2	5/8	TBL914	403.00
3/4-14	2	5/8	TBL915	403.00
1-11	2 1/4	11/16	TBL916	697.00
1-11	3	7/8	TBL917	922.00
1 1/4-11	3	7/8	TBL918	922.00
1 1/2-11	4	1	TBL919	2884.00
2-11	4	1	TBL920	2884.00

CLARKSON OSBORN

BRITISH STANDARD PIPE FINE - BSPF

BSPF Size	∅"	Thickness"	Model No.	Price /Each
1/8-28	1	3/8	BM163	64.70
1/8-28	1 5/16	7/16	TBL921	97.30
1/8-28	1 1/2	1/2	BM165	150.00
1/4-19	1 5/16	7/16	BM164	97.30
1/4-19	1 1/2	1/2	BM166	116.00
1/4-19	2	5/8	TBL922	217.00
3/8-19	1 1/2	1/2	BM167	116.00
3/8-19	2	5/8	TBL923	217.00
1/2-14	2	5/8	BM168	172.00
5/8-14	2	5/8	BM169	217.00
3/4-14	2	5/8	BM170	217.00
1-11	2 1/4	11/16	TBL924	306.00
1-11	3	7/8	BM171	374.00
1 1/4-11	3	7/8	BM172	374.00

HEXAGONAL DIE NUTS

- Maintenance duty
- Carbon steel
- Right hand cut

Application:

For cutting external screw threads, either by hand, using a die stock or by machine, using a floating die holder



CLARKSON OSBORN

NATIONAL FINE - NF

NF Size	A"	Thickness"	Model No.	Price /Each
1/4-28	0.710	1/4	BM640	18.60
5/16-24	0.820	5/16	BM641	20.70
3/8-24	0.920	3/8	BM642	22.10
7/16-20	1.010	7/16	BM643	24.90
1/2-20	1.100	1/2	BM644	26.90
9/16-18	1.300	5/8	BM645	29.00
5/8-18	1.300	5/8	BM646	33.20
3/4-16	1.480	11/16	BM647	47.00
7/8-14	1.670	13/16	BM648	48.30
1-12	2.050	15/16	BM649	52.50
1 1/8-12	2.220	1 1/16	BM650	62.10
1 1/4-12	2.220	1 1/16	BM651	71.80
1 3/8-12	2.580	1 1/8	BM652	81.50
1 1/2-12	2.760	1 1/4	BM653	91.20

NATIONAL COARSE - NC

NC Size	A"	Thickness"	Model No.	Price /Each
1/4-20	0.710	1/4	BM626	18.60
5/16-18	0.820	5/16	BM627	20.70
3/8-16	0.920	3/8	BM628	22.10
7/16-14	1.010	7/16	BM629	24.90
1/2-13	1.100	1/2	BM630	26.90
9/16-12	1.300	5/8	BM631	29.00
5/8-11	1.300	5/8	BM632	33.20
3/4-10	1.480	11/16	BM633	47.00
7/8-9	1.670	13/16	BM634	48.30
1-8	2.050	15/16	BM635	52.50
1 1/8-7	2.220	1 1/16	BM636	62.10
1 1/4-7	2.220	1 1/16	BM637	71.80
1 3/8-6	2.580	1 1/8	BM638	81.50
1 1/2-6	2.760	1 1/4	BM639	91.20

The ultimate!

210-Piece Socket Set, made of chrome vanadium steel for extra strength and durability.

aurora tools®



Model TLV362
See page 1313

HEXAGONAL DIE NUTS

- Industrial duty
- High speed steel
- Right hand cut

Applications:

For cutting external screw threads, either by hand, using a die stock or by machine, using a floating die holder



NATIONAL FINE - NF

HSS-NF Size	A"	Thickness"	Model No.	Price /Each
1/4-28	0.710	1/4	BM671	42.80
5/16-24	0.820	5/16	BM672	49.90
3/8-24	0.920	3/8	BM673	57.90
7/16-20	1.010	7/16	BM674	73.40
1/2-20	1.100	1/2	BM675	73.40
9/16-18	1.300	5/8	BM676	90.50
5/8-18	1.300	5/8	BM677	90.50
3/4-16	1.480	11/16	BM678	109.00
7/8-14	1.670	13/16	BM679	125.00
1-12	2.050	15/16	BM680	182.00
1 1/8-12	2.220	1 1/16	BM681	237.00
1 1/4-12	2.220	1 1/16	BM682	330.00
1 3/8-12	2.580	1 1/8	BM683	375.00
1 1/2-12	2.760	1 1/4	BM684	420.00

NATIONAL COARSE - NC

HSS-NC Size	A"	Thickness"	Model No.	Price /Each
1/4-20	0.710	1/4	BM655	42.80
5/16-18	0.820	5/16	BM656	49.90
3/8-16	0.920	3/8	BM657	57.90
7/16-14	1.010	7/16	BM658	73.40
1/2-13	1.100	1/2	BM659	73.40
9/16-12	1.300	5/8	BM660	90.50
5/8-11	1.300	5/8	BM661	90.50
3/4-10	1.480	11/16	BM662	110.00
7/8-9	1.670	13/16	BM663	125.00
1-8	2.050	15/16	BM664	182.00
1 1/8-7	2.220	1 1/16	BM665	237.00
1 1/4-7	2.220	1 1/16	BM666	330.00
1 3/8-6	2.580	1 1/8	BM667	375.00
1 1/2-6	2.760	1 1/4	BM668	420.00
1 3/4-5	3.150	1 3/8	BM669	600.00
2-4.5	3.550	1 3/4	BM670	745.00

METRIC

Metric Size	A"	Thickness"	Model No.	Price /Each
M3 X 0.5	0.710	1/4	TBL925	43.30
M4 X 0.7	0.710	1/4	BM685	43.30
M5 X 0.8	0.710	1/4	TBL926	42.60
M6 X 1	0.710	1/4	BM686	40.50
M7 X 1	0.820	5/16	TBL927	46.00
M8 X 1.25	0.820	5/16	BM687	46.00
M9 X 1.25	0.920	3/8	BM688	53.60
M10 X 1.5	0.920	3/8	BM689	53.60
M11 X 1.5	1.010	7/16	BM690	75.60
M12 X 1.75	1.100	1/2	BM691	75.60

METRIC

Metric Size	A"	Thickness"	Model No.	Price /Each
M14 X 2	1.300	5/8	BM692	89.30
M16 X 2	1.300	5/8	BM693	89.30
M18 X 2.5	1.480	11/16	BM694	102.00
M20 X 2.5	1.480	11/16	BM695	102.00
M22 X 2.5	1.670	13/16	BM696	130.00
M24 X 3	2.050	15/16	BM697	206.00
M27 X 3	2.220	1 1/16	BM698	323.00
M30 X 3.5	2.220	1 1/16	BM699	323.00
M33 X 3.5	2.580	1 1/8	TBL928	436.00
M36 X 4	2.760	1 1/4	TBL929	436.00

METRIC FINE

Metric Fine Size	A"	Thickness"	Model No.	Price /Each
MF3 X 0.35	0.710	1/4	TBL930	457.00
MF4 X 0.50	0.710	1/4	TBL931	264.00
MF5 X 0.50	0.710	1/4	TBL932	68.70
MF6 X 0.75	0.710	1/4	TBL933	61.80
MF7 X 0.75	0.820	3/8	TBL934	220.00
MF8 X 1	0.820	3/8	TBL935	68.70
MF10 X 1	0.920	3/8	BM700	99.60
MF12 X 1.25	1.100	1/2	BM701	110.00
MF14 X 1.5	1.300	1/2	BM702	120.00
MF16 X 1.5	1.300	1/2	TBL936	120.00
MF18 X 1.5	1.480	1/2	TBL937	151.00
M20 X 1.5	1.480	5/8	BM703	151.00
MF22 X 1.5	1.670	5/8	BM704	165.00
MF24 X 2	2.050	5/8	TBL938	254.00
MF25 X 1.5	2.050	5/8	TBL939	254.00

BRITISH STANDARD WHITWORTH - BSW

BSW Size	A"	Thickness"	Model No.	Price /Each
1/8-40	0.710	1/4	TBL940	142.00
3/16-24	0.710	1/4	TBL941	114.00
1/4-20	0.710	1/4	TBL942	71.90
5/16-18	0.820	5/16	TBL943	85.70
3/8-16	0.920	3/8	TBL944	99.50
7/16-14	1.010	7/16	TBL945	137.00
1/2-12	1.100	1/2	TBL946	122.00
9/16-12	1.300	5/8	TBL947	151.00
5/8-11	1.300	5/8	TBL948	151.00
3/4-10	1.480	11/16	TBL949	185.00
7/8-9	1.670	13/16	TBL950	213.00
1-8	2.050	15/16	TBL951	310.00
1 1/8-7	2.220	1 1/16	TBL952	418.00
1 1/4-7	2.220	1 1/16	TBL953	512.00
1 1/2-6	2.760	1 1/4	TBL954	672.00
1 3/4-5	3.150	1 3/8	TBL955	828.00
2-4.5	3.550	1 3/4	TBL956	1024.00

BRITISH STANDARD FINE - BSW

BSF Size	A"	Thickness"	Model No.	Price /Each
1/4-26	0.710	1/4	TBL957	71.90
5/16-22	0.820	5/16	BM705	85.70
3/8-20	0.920	3/8	BM706	99.50
7/16-18	1.010	7/16	TBL958	137.00
1/2-16	1.100	1/2	TBL959	122.00
9/16-16	1.300	5/8	TBL960	151.00
5/8-14	1.300	5/8	TBL961	151.00
11/16-14	1.480	11/16	TBL962	232.00
3/4-12	1.480	11/16	TBL963	185.00
7/8-11	1.670	13/16	TBL964	213.00
1-10	2.050	15/16	TBL965	310.00
1 1/8-9	2.220	1 1/16	TBL966	418.00
1 1/4-9	2.220	1 1/16	TBL967	512.00
1 1/2-8	2.760	1 1/4	BM707	672.00
1 3/4-7	3.150	1 3/8	TBL968	821.00
2-7	3.550	1 3/4	TBL969	1024.00

CUTTING TOOLS

SPLIT CIRCULAR DIES

- Industrial duty
- High speed steel
- Right hand cut

Applications:

For cutting external screw threads, either by hand, using a die stock or by machine, using a floating die holder



CLARKSON  **OSBORN**

MACHINE SCREW SIZES

Machine Screw Size	Ø"	Thickness"	Model No.	Price /Each
#0-80 NF	13/16	1/4	BM084	46.40
#1-64 NC	13/16	1/4	BM075	46.40
#1-72 NF	13/16	1/4	BM085	46.40
#2-56 NC	13/16	1/4	BM076	46.40
#2-64 NF	13/16	1/4	BM086	46.40
#3-48-NC	13/16	1/4	BM077	46.40
#3-56 NF	13/16	1/4	BM087	46.40
#4-40 NC	13/16	1/4	BM078	46.40
#4-48 NF	13/16	1/4	BM088	46.40
#5-40 NC	13/16	1/4	BM079	46.40
#5-44 NF	13/16	1/4	BM089	46.40
#6-32 NC	13/16	1/4	BM080	46.40
#6-40 NF	13/16	1/4	BM090	46.40
#8-32 NC	13/16	1/4	BM081	46.40
#8-36 NF	13/16	1/4	BM091	46.40
#10-24 NC	13/16	1/4	BM082	46.40
#10-32 NF	13/16	1/4	BM092	46.40
#12-24 NC	13/16	1/4	BM083	46.40
#12-28 NF	13/16	1/4	BM093	46.40

FRACTIONAL - NATIONAL COARSE (NC)

National Coarse Size - NC	Ø"	Thickness"	Model No.	Price /Each
1/4-20	13/16	1/4	BM094	46.40
1/4-20	1	3/8	BM096	58.00
1/4-20	1 5/16	7/16	BM102	94.30
5/16-18	1	3/8	BM097	58.00
5/16-18	1 5/16	7/16	BM103	94.30
3/8-16	1	3/8	BM098	58.00
3/8-16	1 5/16	7/16	BM104	94.30
3/8-16	1 1/2	1/2	BM114	94.30
7/16-14	1 5/16	7/16	BM105	94.30
7/16-14	1 1/2	1/2	BM115	94.30
1/2-13	1 5/16	7/16	BM106	94.30
1/2-13	1 1/2	1/2	BM116	94.30
1/2-13	2	5/8	BM126	165.00
9/16-12	1 5/16	7/16	BM107	94.30
9/16-12	1 1/2	1/2	BM117	94.30
9/16-12	2	5/8	BM127	165.00
5/8-11	1 1/2	1/2	BM118	94.30
5/8-11	2	5/8	BM128	165.00
3/4-10	1 1/2	1/2	BM119	94.30
3/4-10	2	5/8	BM129	165.00
7/8-9	2	5/8	TBL975	165.00
1-8	2	5/8	BM131	165.00
1-8	3	7/8	BM139	293.00
1 1/8-7	3	7/8	BM140	293.00
1 1/4-7	3	7/8	BM141	293.00
1 3/8-6	3	7/8	BM142	293.00
1 1/2-6	3	7/8	BM143	293.00

FRACTIONAL - NATIONAL FINE (NF)

National Fine Size - NF	Ø"	Thickness"	Model No.	Price /Each
1/4-28	13/16	1/4	BM095	46.40
1/4-28	1	3/8	BM099	58.00
1/4-28	1 5/16	7/16	BM108	94.30
5/16-24	1	3/8	BM100	58.00
5/16-24	1 5/16	7/16	BM109	94.30
3/8-24	1	3/8	BM101	58.00
3/8-24	1 5/16	7/16	BM110	94.30
3/8-24	1 1/2	1/2	BM120	94.30
7/16-20	1 5/16	7/16	BM111	94.30
7/16-20	1 1/2	1/2	BM121	94.30
1/2-20	1 5/16	7/16	BM112	94.30
1/2-20	1 1/2	1/2	BM122	94.30
1/2-20	2	5/8	BM132	165.00
9/16-18	1 5/16	7/16	BM113	94.30
9/16-18	1 1/2	1/2	BM123	94.30
9/16-18	2	5/8	BM133	165.00
5/8-18	1 1/2	1/2	BM124	94.30
5/8-18	2	5/8	BM134	165.00
3/4-16	1 1/2	1/2	BM125	94.30
3/4-16	2	5/8	BM135	165.00
7/8-14	2	5/8	BM136	165.00
1-12	2	5/8	BM137	165.00
1-12	3	7/8	BM144	293.00
1 1/8-12	3	7/8	BM145	293.00
1 1/4-12	3	7/8	BM146	293.00
1 3/8-12	3	7/8	BM147	293.00
1 1/2-12	3	7/8	BM148	293.00

METRIC SIZES

Metric Size	Ø"	Thickness"	Model No.	Price /Each
M1.4X0.30	13/16	1/4	TBL976	41.30
M1.6X0.35	13/16	1/4	BM523	41.30
M1.8X0.35	13/16	1/4	BM523	41.30
M2.0X0.40	13/16	1/4	BM524	41.30
M2.2X0.45	13/16	1/4	BM525	41.30
M2.5X0.45	13/16	1/4	BM526	41.30
M3.0X0.5	13/16	1/4	BM527	41.30
M3.5X0.6	13/16	1/4	BM528	41.30
M4.0X0.7	13/16	1/4	BM529	41.30
M4.0X0.7	1	3/8	BM537	51.50
M4.5X0.75	13/16	1/4	TBL977	41.30
M5.0X0.8	13/16	1/4	BM531	41.30
M5X0.8	1	3/8	BM538	51.50
M6 X1	13/16	1/4	TBL978	41.30
M6X1	1	3/8	BM539	51.50
M6 X1	1 5/16	7/16	BM547	82.70
M7 X1	13/16	1/4	BM533	41.30
M7 X1	1	3/8	BM540	51.50
M7 X1	1 5/16	7/16	BM548	82.70
M8 X1.25	1	3/8	BM534	51.50
M8 X1.25	1 5/16	7/16	BM541	82.70
M9 X1.25	1	3/8	BM535	51.50
M9 X1.25	1 5/16	7/16	BM542	82.70
M10 X1.5	1	3/8	BM536	51.50

Metric Size	Ø"	Thickness"	Model No.	Price /Each
M10X1.5	1 5/16	7/16	BM543	82.70
M10X1.5	1 1/2	1/2	BM549	82.70
M11 X1.5	1 5/16	7/16	BM544	82.70
M11 X1.5	1 1/2	1/2	BM550	82.70
M12 X1.75	1 5/16	7/16	BM545	82.70
M12 X1.75	1 1/2	1/2	BM551	82.70
M12 X1.75	2	5/8	BM556	131.00
M14 X2	1 5/16	7/16	BM546	82.70
M14 X2	1 1/2	1/2	BM552	82.70
M14 X2	2	5/8	BM557	131.00
M16 X2	1 1/2	1/2	BM553	82.70
M16 X2	2	5/8	BM558	131.00
M18 X2.5	1 1/2	1/2	BM554	82.70
M18 X2.5	2	5/8	BM559	131.00
M20 X2.5	1 1/2	1/2	BM555	82.70
M20 X2.5	2	5/8	BM560	131.00
M22 X2.5	2	5/8	BM561	131.00
M24 X3	2	5/8	BM562	131.00
M27 X3	3	7/8	BM563	262.00
M30 X3.5	3	7/8	BM564	262.00
M33 X3.5	3	7/8	TBL979	262.00
M36 X4	3	7/8	BM565	262.00
M39 X4	3	7/8	BM566	262.00

METRIC FINE SIZES

Metric Fine Size	Ø"	Thickness"	Model No.	Price /Each
MF3 X0.35	13/16	1/4	BM567	78.40
MF4 X0.5	13/16	1/4	BM568	78.40
MF5 X0.5	13/16	1/4	BM569	78.40
MF6 X0.75	13/16	1/4	BM570	78.40
MF8 X1	1	3/8	BM580	89.30
MF10 X1	1	3/8	TBL980	89.30
MF10 X1.25	1	3/8	TBL981	89.30
MF12 X1.25	1 5/16	7/16	BM572	135.00
MF14 X1.5	1 5/16	7/16	BM573	135.00

Metric Fine Size	Ø"	Thickness"	Model No.	Price /Each
MF16 X1.5	1 1/2	1/2	BM574	166.00
MF18 X1.5	1 1/2	1/2	BM575	166.00
MF20 X1.5	2	5/8	BM576	250.00
MF22 X1.5	2	5/8	BM577	250.00
MF24 X2	2	5/8	BM578	250.00
MF25 X1.5	2	5/8	BM579	250.00
MF27 X2	3	7/8	TBL982	523.00
MF30 X2	3	7/8	TBL983	523.00
MF32 X1.5	3	7/8	TBL984	523.00

HAND REAMERS

- High speed steel
- Right hand cutting direction
- Spiral flute
- Straight shank
- Ground starting taper on cutting end for easy entry

Applications:

Hand reamers are designed for extreme accuracy and are used by hand for final sizing of drilled holes. The square shank end fits in a tap wrench.

CLARKSON OSBORN



FRACTIONAL SIZES

Fractional Size	Decimal Equiv."	L2mm	L1mm	Model No.	Price /Each
1/16	0.0625	21.0	44.0	BK453	67.00
3/32	0.0938	29.0	58.0	BK454	50.00
1/8	0.1250	33.0	66.0	BK455	37.80
9/64	0.1406	35.0	71.0	BK456	44.50
5/32	0.1562	38.0	76.0	BK457	41.10
11/64	0.1719	41.0	81.0	BK458	44.90
3/16	0.1875	44.0	87.0	BK459	41.50
13/64	0.2031	44.0	87.0	BK460	47.90
7/32	0.2188	48.0	93.0	BK461	44.10
15/64	0.2344	48.0	93.0	TBM143	48.40
1/4	0.2500	50.0	100.0	BK462	42.40
17/64	0.2656	54.0	107.0	BK463	51.70
9/32	0.2812	54.0	107.0	BK464	49.10
19/64	0.2969	58.0	115.0	BK465	55.50
5/16	0.3125	58.0	115.0	BK466	49.10
21/64	0.3281	58.0	115.0	BK467	58.00
11/32	0.3438	62.0	124.0	BK468	61.00

Fractional Size	Decimal Equiv."	L2mm	L1mm	Model No.	Price /Each
23/64	0.3594	62.0	124.0	BK469	70.40
3/8	0.3750	66.0	133.0	BK470	56.80
25/64	0.3906	66.0	133.0	BK471	71.20
13/32	0.4062	66.0	133.0	BK472	68.20
27/64	0.4219	71.0	142.0	BK473	76.70
7/16	0.4375	71.0	142.0	BK474	67.40
29/64	0.4531	71.0	142.0	BK475	84.80
15/32	0.4688	76.0	152.0	BK476	73.30
31/64	0.4844	76.0	152.0	BK477	93.30
1/2	0.5000	76.0	152.0	BK478	65.30
17/32	0.5312	81.0	163.0	BK479	87.80
9/16	0.5625	81.0	163.0	BK480	82.70
19/32	0.5938	87.0	175.0	BK481	110.00
5/8	0.6250	87.0	175.0	BK482	83.50
21/32	0.6562	87.0	175.0	BK483	125.00
11/16	0.6875	93.0	188.0	BK484	109.00
23/32	0.7188	93.0	188.0	BK485	142.00
3/4	0.7500	100.0	201.0	BK486	114.00

Fractional Size	Decimal Equiv."	L2mm	L1mm	Model No.	Price /Each
25/32	0.7813	100.0	201.0	BK487	208.00
13/16	0.8125	100.0	201.0	BK488	133.00
27/32	0.8438	107.0	215.0	BK489	220.00
7/8	0.8750	107.0	215.0	BK490	143.00
29/32	0.9062	107.0	215.0	BK491	220.00
15/16	0.9375	115.0	231.0	BK492	200.00
31/32	0.9688	115.0	231.0	BK493	265.00
1	1.0000	115.0	231.0	BK494	210.00
1 1/16	1.0625	124.0	247.0	BK495	242.00
1 1/8	1.1250	124.0	247.0	BK496	235.00
1 1/4	1.2500	133.0	265.0	BK497	286.00
1 3/8	1.3750	142.0	284.0	BK498	348.00
1 1/2	1.5000	152.0	305.0	BK499	420.00
1 5/8	1.6250	152.0	305.0	BK500	475.00
1 3/4	1.7500	163.0	326.0	BK501	615.00
1 7/8	1.8750	174.0	347.0	TBM144	734.00
2	2.0000	174.0	347.0	BK502	762.00

METRIC SIZES

Metric Size	Decimal Equiv."	L2mm	L1mm	Model No.	Price /Each
2.00	0.0787	25.0	50.0	BK503	55.50
2.50	0.0984	29.0	58.0	BK504	50.00
3.00	0.1181	31.0	62.0	BK505	43.20
3.50	0.1378	35.0	71.0	BK506	37.80
4.00	0.1575	38.0	76.0	BK507	38.20
4.50	0.1772	41.0	81.0	BK508	42.00
5.00	0.1969	44.0	87.0	BK509	40.30
5.50	0.2165	48.0	93.0	BK510	47.10
6.00	0.2362	48.0	93.0	BK511	42.40
6.50	0.2559	50.0	100.0	BK512	47.10
7.00	0.2756	54.0	107.0	BK513	44.10
7.50	0.2953	58.0	115.0	BK514	49.10
8.00	0.3150	58.0	115.0	BK515	49.10
8.50	0.3346	58.0	115.0	BK516	53.00
9.00	0.3543	62.0	124.0	BK517	57.20
9.50	0.3740	62.0	124.0	BK518	62.70

Metric Size	Decimal Equiv."	L2mm	L1mm	Model No.	Price /Each
10.00	0.3937	66.0	133.0	BK519	56.80
10.50	0.4134	66.0	133.0	BK520	66.10
11.00	0.4331	71.0	142.0	BK521	66.10
11.50	0.4528	71.0	142.0	BK522	70.80
12.00	0.4724	76.0	152.0	BK523	64.00
12.50	0.4921	76.0	152.0	BK524	72.50
13.00	0.5118	76.0	152.0	BK525	66.60
13.50	0.5315	81.0	163.0	BK526	86.00
14.00	0.5512	81.0	163.0	BK527	82.70
15.00	0.5906	81.0	163.0	BK528	90.30
16.00	0.6299	87.0	175.0	BK529	88.60
17.00	0.6693	87.0	175.0	BK530	101.00
18.00	0.7087	93.0	188.0	BK531	101.00
19.00	0.7480	93.0	188.0	BK532	114.00
20.00	0.7874	100.0	201.0	BK533	117.00
21.00	0.8268	100.0	201.0	BK534	138.00

Metric Size	Decimal Equiv."	L2mm	L1mm	Model No.	Price /Each
22.00	0.8661	107.0	215.0	BK535	148.00
23.00	0.9055	107.0	215.0	BK536	161.00
24.00	0.9449	115.0	231.0	BK537	187.00
25.00	0.9843	115.0	231.0	BK538	210.00
26.00	1.0236	115.0	231.0	BK539	220.00
27.00	1.0630	124.0	247.0	BK540	233.00
28.00	1.1024	124.0	247.0	BK541	231.00
30.00	1.1811	124.0	247.0	BK542	273.00
32.00	1.2598	133.0	265.0	BK543	295.00
33.00	1.2992	133.0	265.0	BK544	342.00
34.00	1.3386	142.0	284.0	BK545	345.00
35.00	1.3780	142.0	284.0	BK546	384.00
36.00	1.4173	142.0	284.0	BK547	377.00
38.00	1.4961	152.0	305.0	BK548	424.00
40.00	1.5748	152.0	305.0	BK549	486.00

STRAIGHT SHANK ALIGNING REAMERS

- Right hand cut
- High speed steel
- Straight shank
- Spiral flute

Applications:

Aligning Reamers are designed for aligning holes in structural steel fabrication for bridgework, ship construction, automotive maintenance, and railroad car manufacturing. Their shorter length makes for easier work in tight areas. Can be used in any 1/2" 3 jaw power tool.



FRACTIONAL SIZES

Fractional Size	Decimal Equiv."	L2mm	L1mm	Model No.	Price /Each
1/4	0.2500	2.5	4.375	TC0036	84.00
5/16	0.3125	2.75	4.625	TC0037	84.00
3/8	0.3750	2.75	4.625	TC0038	84.00
7/16	0.4375	3.5	5.375	TC0039	87.10
1/2	0.5000	4.0	5.875	TC0040	87.10
9/16	0.5625	4.0	5.875	TC0041	97.00
39/64	0.6094	4.5	6.375	TC0042	109.00
5/8	0.6250	4.5	6.375	TC0043	101.00

Fractional Size	Decimal Equiv."	L2mm	L1mm	Model No.	Price /Each
11/16	0.6875	4.5	6.375	TC0044	112.00
3/4	0.7500	5.0	6.875	TC0045	134.00
13/16	0.8125	5.0	6.875	TC0046	136.00
7/8	0.8750	5.0	6.875	TC0047	145.00
15/16	0.9375	5.0	6.875	TC0048	152.00
1	1.0	5.0	6.875	TC0049	178.00
11/16	1.0625	5.0	6.875	TC0050	208.00

CUTTING TOOLS

TAPER PIN REAMERS

- Right hand cut
- High speed steel
- Straight shank
- Straight flute

Application:

Taper Pin Reamers are manufactured with a taper of 1/4" per foot. They are used to ream holes into which standard taper pins will fit. The point of each reamer will enter hole reamed by next smaller size. Hole to be reamed should be a few thousandths smaller than the small diameter of the finished reamed hole.

Fractional Size	D1"	D2"	L2"	L1"	Model No.	Price /Each
5/64	0.0592	0.0800	1	2	TBM090	69.50
3/32	0.0690	0.0950	1 1/4	2 1/4	TBM091	57.20
7/64	0.0798	0.1110	1 1/2	2 1/2	TBM092	61.00
1/8	0.0905	0.1270	1 3/4	2 3/4	BK404	47.50
9/64	0.1039	0.1430	1 7/8	2 7/8	TBM093	60.20
5/32	0.1163	0.1580	2	3	BK405	54.50
11/64	0.1271	0.1740	2 1/4	3 1/2	BK406	58.90
3/16	0.1377	0.1950	2 3/4	4	BK407	57.40
7/32	0.1627	0.2200	2 3/4	4	BK408	61.40
1/4	0.1827	0.2530	3 3/8	4 5/8	BK409	59.70

METRIC SIZES

mm	D1mm	D2mm	L2mm	L1mm	Model No.	Price /Each
2.0	1.90	2.86	48.0	68.0	BK440	47.00
2.5	2.40	3.36	48.0	68.0	BK441	48.40
3.0	2.90	4.06	58.0	80.0	BK442	49.60
4.0	3.90	5.26	68.0	93.0	BK443	55.50
5.0	4.90	6.36	73.0	100.0	BK444	59.70
6.0	5.90	8.00	105.0	135.0	BK445	69.50
8.0	7.90	10.80	145.0	180.0	BK446	88.10

NUMBER SIZES

Number Size	D1"	D2"	L2"	L1"	Model No.	Price /Each
7/0	0.0497	0.0666	13/16	1 13/16	TBM095	38.20
6/0	0.0611	0.0806	15/16	1 15/16	BK423	38.20
5/0	0.0719	0.0966	1 3/16	2 3/16	BK422	34.90
4/0	0.0869	0.1142	1 5/16	2 5/16	BK421	34.90
3/0	0.1029	0.1302	1 5/16	2 5/16	BK420	34.90
2/0	0.1137	0.1462	1 9/16	2 9/16	BK419	31.20
0.0	0.1287	0.1638	1 11/16	2 15/16	BK424	29.90
1	0.1447	0.1798	1 11/16	2 15/16	BK425	29.10
2	0.1605	0.2008	1 15/16	3 3/16	BK426	29.10
3	0.1813	0.2294	2 5/16	3 11/16	BK427	29.10
4	0.2071	0.2604	2 9/16	4 1/16	BK428	32.40
5	0.2409	0.2994	2 13/16	4 5/16	BK429	34.90
6	0.2773	0.3540	3 11/16	5 7/16	BK430	42.10
7	0.3297	0.4220	4 7/16	6 5/16	BK431	54.20
8	0.3971	0.5050	5 3/16	7 3/16	BK432	69.30
9	0.4805	0.6066	6 1/16	8 5/16	BK433	84.90
10	0.5799	0.7216	6 13/16	9 5/16	BK434	115.00
11	0.7060	0.8780	8 1/4	11 1/4	BK435	228.00
12	0.8420	1.0500	10	13 5/8	BK436	326.00
13	1.0090	1.2590	12	16	BK437	485.00
14	1.2500	1.5420	14	18 1/4	BK438	613.00

CLARKSON OSBORN

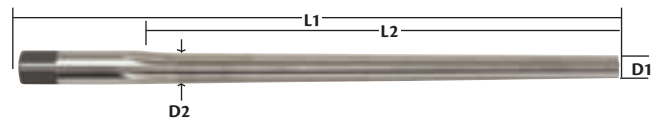

Fractional Size	D1"	D2"	L2"	L1"	Model No.	Price /Each
9/32	0.2061	0.2920	4 1/8	5 5/8	BK410	70.20
5/16	0.2301	0.3160	4 1/8	5 5/8	BK411	73.30
11/32	0.2533	0.3470	4 1/2	6	BK412	73.10
3/8	0.2768	0.3810	5	6 1/2	BK413	81.40
13/32	0.2922	0.4120	5 3/4	7 1/2	TBM094	95.80
7/16	0.3232	0.4430	5 3/4	7 1/2	BK414	99.20
1/2	0.3706	0.5060	6 1/2	8 1/4	BK415	139.00
9/16	0.4304	0.5710	6 3/4	8 1/2	BK416	210.00
5/8	0.4768	0.6330	7 1/2	9 1/4	BK417	237.00
3/4	0.5777	0.7600	8 3/4	10 3/4	BK418	280.00

mm	D1mm	D2mm	L2mm	L1mm	Model No.	Price /Each
10.0	9.90	13.40	175.0	215.0	BK447	113.00
12.0	11.80	16.00	194.0	240.0	BK448	130.00
13.0	12.86	16.74	194.0	240.0	BK449	158.00
14.0	13.86	17.76	194.0	240.0	BK450	216.00
16.0	15.80	20.40	230.0	280.0	BK451	263.00
20.0	19.80	24.80	230.0	310.0	BK452	360.00

Fractional Size	D1"	L2"	L1"	Shank Diameter	Model No.	Price /Each
1/4	0.2500	2 1/2	4 3/8	1/4	TC0036	84.00
5/16	0.3125	2 3/4	4 5/8	5/16	TC0037	84.00
3/8	0.3750	2 3/4	4 5/8	3/8	TC0038	84.00
7/16	0.4375	3 1/2	5 3/8	7/16	TC0039	87.10
1/2	0.5000	4	5 7/8	1/2	TC0040	87.10
9/16	0.5625	4	5 7/8	1/2	TC0041	97.00
39/64	0.6094	4 1/2	6 3/8	1/2	TC0042	109.00
5/8	0.6250	4 1/2	6 3/8	1/2	TC0043	101.00
11/16	0.6875	4 1/2	6 3/8	1/2	TC0044	112.00
3/4	0.7500	5	6 7/8	1/2	TC0045	134.00
13/16	0.8125	5	6 7/8	1/2	TC0046	136.00
7/8	0.8750	5	6 7/8	1/2	TC0047	145.00
15/16	0.9375	5	6 7/8	1/2	TC0048	152.00
1	1	5	6 7/8	1/2	TC0049	178.00
1 1/16	1.0625	5	6 7/8	1/2	TC0050	208.00

Fractional Size	D1"	L2"	L1"	Hex Diameter	Model No.	Price /Each
11/16	0.6875	4 1/2	6 1/2	1 1/16	TC0051	133.00
13/16	0.8125	5	7	1 1/4	TC0052	162.00
15/16	0.9375	5	7	1 7/16	TC0053	180.00
1 1/16	1.0625	5	7	1 5/8	TC0054	242.00

ZENITH
Safety Products

100% Canadian Owned Company

**Rain or shine ...
for affordable quality
safety products, ZENITH
is your ideal choice!**

CHUCKING REAMERS - HIGH SPEED STEEL

- Right hand cut
- High speed steel
- Straight shank
- Straight flute

Application:

Straight Flute Chucking Reamers are designed for general purpose reaming. Ground with 45° chamfer.

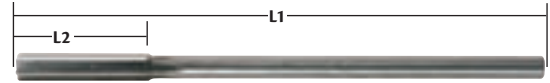

FRACTIONAL SIZES

Fractional Size	Decimal Equiv."	L2"	L1"	Model No.	Price /Each
3/64	0.0469	1/2	2 1/2	BK156	37.10
1/16	0.0625	1/2	2 1/2	BK157	33.30
5/64	0.0781	3/4	3	BK158	29.90
3/32	0.0938	3/4	3	BK159	27.40
7/64	0.1094	7/8	3 1/2	BK160	31.10
1/8	0.1250	7/8	3 1/2	BK161	14.90
9/64	0.1406	1	4	BK162	23.00
5/32	0.1562	1	4	BK163	20.90
11/64	0.1719	1 1/8	4 1/2	BK164	23.00
3/16	0.1875	1 1/8	4 1/2	BK165	20.90
13/64	0.2031	1 1/4	5	BK166	27.80
7/32	0.2188	1 1/4	5	BK167	26.90
15/64	0.2344	1 1/2	6	BK168	27.80
1/4	0.2500	1 1/2	6	BK169	24.30
17/64	0.2656	1 1/2	6	BK170	31.00
9/32	0.2812	1 1/2	6	BK171	31.00
19/64	0.2969	1 1/2	6	BK172	32.70
5/16	0.3125	1 1/2	6	BK173	28.90
21/64	0.3281	1 1/2	6	BK174	35.40
11/32	0.3438	1 1/2	6	BK175	35.40
23/64	0.3594	1 3/4	7	BK176	35.40
3/8	0.3750	1 3/4	7	BK177	31.00
25/64	0.3906	1 3/4	7	BK178	36.60
13/32	0.4062	1 3/4	7	BK179	38.00
27/64	0.4219	1 3/4	7	BK180	40.20
7/16	0.4375	1 3/4	7	BK181	36.60
29/64	0.4531	1 3/4	7	BK182	44.80

Fractional Size	Decimal Equiv."	L2"	L1"	Model No.	Price /Each
15/32	0.4688	1 3/4	7	BK183	43.50
31/64	0.4844	2	8	BK184	44.80
1/2	0.5000	2	8	BK185	40.20
17/32	0.5313	2	8	BK186	47.80
9/16	0.5625	2	8	BK187	46.80
19/32	0.5938	2	8	BK188	54.50
5/8	0.6250	2 1/4	9	BK189	54.50
21/32	0.6563	2 1/4	9	BK190	54.50
11/16	0.6875	2 1/4	9	BK191	62.00
23/32	0.7188	2 1/4	9	BK192	71.90
3/4	0.7500	2 1/2	9 1/2	BK193	69.00
25/32	0.7813	2 1/2	9 1/2	BK194	80.60
13/16	0.8125	2 1/2	9 1/2	BK195	80.60
27/32	0.8438	2 1/2	9 1/2	BK196	91.40
7/8	0.8750	2 5/8	10	BK197	89.30
29/32	0.9063	2 5/8	10	BK198	101.00
15/16	0.9375	2 5/8	10	BK199	101.00
31/32	0.9688	2 5/8	10	BK200	113.00
1	1.0000	2 3/4	10 1/2	BK201	111.00
1 1/16	1.0625	2 3/4	10 1/2	BK202	127.00
1 1/8	1.1250	2 7/8	11	BK203	136.00
1 3/16	1.1875	2 7/8	11	BK204	153.00
1 1/4	1.2500	3	11 1/2	BK205	167.00
1 5/16	1.3125	3	11 1/2	BK206	184.00
1 3/8	1.3750	3 1/4	12	BK207	202.00
1 7/16	1.4375	3 1/4	12	BK208	220.00
1 1/2	1.5000	3 1/2	12 1/2	BK209	237.00

WIRE GAUGE SIZES

Wire No.	Decimal Equiv."	L2"	L1"	Model No.	Price /Each
60	0.0400	1/2	2 1/2	BK269	30.60
59	0.0410	1/2	2 1/2	BK268	30.60
58	0.0420	1/2	2 1/2	BK267	30.60
57	0.0430	1/2	2 1/2	BK266	30.60
56	0.0465	1/2	2 1/2	BK265	30.60
55	0.0520	1/2	2 1/2	BK264	30.60
54	0.0550	1/2	2 1/2	BK263	30.60
53	0.0595	1/2	2 1/2	BK262	30.60
52	0.0635	1/2	2 1/2	BK261	28.50
51	0.0670	3/4	3	BK260	24.70
50	0.0700	3/4	3	BK259	24.70
49	0.0730	3/4	3	BK258	24.70
48	0.0760	3/4	3	BK257	24.70
47	0.0785	3/4	3	BK256	24.70
46	0.0810	3/4	3	BK255	24.70
45	0.0820	3/4	3	BK254	24.70
44	0.0860	3/4	3	BK253	24.70
43	0.0890	3/4	3	BK252	24.70
42	0.0935	3/4	3	BK251	24.70
41	0.0960	7/8	3 1/2	BK250	24.70
40	0.0980	7/8	3 1/2	BK249	23.70
39	0.0995	7/8	3 1/2	BK248	23.70
38	0.1015	7/8	3 1/2	BK247	23.70
37	0.1040	7/8	3 1/2	BK246	23.70
36	0.1065	7/8	3 1/2	BK245	23.70
35	0.1100	7/8	3 1/2	BK244	23.70
34	0.1110	7/8	3 1/2	BK243	23.70
33	0.1130	7/8	3 1/2	BK242	22.50
32	0.1160	7/8	3 1/2	BK241	22.50
31	0.1200	7/8	3 1/2	BK240	22.50

Wire No.	Decimal Equiv."	L2"	L1"	Model No.	Price /Each
30	0.1285	7/8	3 1/2	BK239	21.80
29	0.1360	1	4	BK238	21.80
28	0.1405	1	4	BK237	21.80
27	0.1440	1	4	BK236	21.80
26	0.1470	1	4	BK235	21.80
25	0.1495	1	4	BK234	21.80
24	0.1520	1	4	BK233	21.80
23	0.1540	1	4	BK232	21.80
22	0.1570	1	4	BK231	21.80
21	0.1590	1 1/8	4 1/2	BK230	21.80
20	0.1610	1 1/8	4 1/2	BK229	21.80
19	0.1660	1 1/8	4 1/2	BK228	21.80
18	0.1695	1 1/8	4 1/2	BK227	21.80
17	0.1730	1 1/8	4 1/2	BK226	23.50
16	0.1770	1 1/8	4 1/2	BK225	23.50
15	0.1800	1 1/8	4 1/2	BK224	25.70
14	0.1820	1 1/8	4 1/2	BK223	25.70
13	0.1850	1 1/8	4 1/2	BK222	25.70
12	0.1890	1 1/8	4 1/2	BK221	25.70
11	0.1910	1 1/4	5	BK220	26.80
10	0.1935	1 1/4	5	BK219	27.60
9	0.1960	1 1/4	5	BK218	27.60
8	0.1990	1 1/4	5	BK217	27.60
7	0.2010	1 1/4	5	BK216	27.60
6	0.2040	1 1/4	5	BK215	27.60
5	0.2055	1 1/4	5	BK214	27.60
4	0.2090	1 1/4	5	BK213	27.60
3	0.2130	1 1/4	5	BK212	27.60
2	0.2210	1 1/4	5	BK211	27.60
1	0.2280	1 1/4	5	BK210	27.60

CUTTING TOOLS

CHUCKING REAMERS - HIGH SPEED STEEL (CONT'D)

- Right hand cut
- High speed steel
- Morse Taper shank
- Spiral flute

Application:

Machine reamers are designed for use on a machine equipped with a Morse taper spindle.

CLARKSON  **OSBORN**



FRACTIONAL SIZES

Fractional Size"	Morse Taper Shank Size	Decimal Equiv."	L2mm	L1mm	Model No.	Price /Each
1/8	MT1	0.1250	33.0	106.0	BK550	50.50
9/64	MT1	0.1406	35.0	108.0	TBM147	64.00
5/32	MT1	0.1562	38.0	112.0	TBM148	61.00
11/64	MT1	0.1719	41.0	115.0	TBM150	70.80
3/16	MT1	0.1875	44.0	118.0	BK551	56.80
13/64	MT1	0.2031	44.0	118.0	TBM152	64.00
7/32	MT1	0.2188	48.0	125.0	BK552	62.70
15/64	MT1	0.2344	48.0	125.0	TBM154	71.20
1/4	MT1	0.2500	50.0	130.0	BK553	56.80
17/64	MT1	0.2656	54.0	134.0	TBM156	72.00
9/32	MT1	0.2813	54.0	134.0	TBM157	64.90
19/64	MT1	0.2969	58.0	138.0	TBM159	70.40
5/16	MT1	0.3125	58.0	138.0	BK554	59.70
21/64	MT1	0.3281	58.0	138.0	TBM160	72.90
11/32	MT1	0.3438	62.0	141.0	BK555	64.00
23/64	MT1	0.3594	62.0	141.0	TBM161	73.70
3/8	MT1	0.3750	67.0	146.0	BK556	59.30
25/64	MT1	0.3906	67.0	146.0	BK557	74.10
13/32	MT1	0.4063	67.0	146.0	BK558	69.50
27/64	MT1	0.4219	71.0	151.0	BK559	77.10
7/16	MT1	0.4375	71.0	151.0	BK560	63.50
29/64	MT1	0.4531	71.0	151.0	TBM163	77.60
15/32	MT1	0.4688	76.0	156.0	TBM164	70.80
31/64	MT1	0.4844	76.0	156.0	TBM165	80.10
1/2	MT1	0.5000	76.0	156.0	BK561	64.00
17/32	MT1	0.5313	81.0	160.0	BK562	75.90

Fractional Size"	Morse Taper Shank Size	Decimal Equiv."	L2mm	L1mm	Model No.	Price /Each
9/16	MT2	0.5625	81.0	181.0	BK563	79.20
19/32	MT2	0.5938	87.0	187.0	TBM166	93.70
5/8	MT2	0.6250	87.0	187.0	BK564	83.90
21/32	MT2	0.6563	87.0	187.0	TBM167	109.00
11/16	MT2	0.6875	94.0	194.0	BK565	100.00
23/32	MT2	0.7188	94.0	194.0	BK566	119.00
3/4	MT2	0.7500	100.0	200.0	BK567	113.00
25/32	MT2	0.7813	100.0	200.0	TBM168	131.00
13/16	MT2	0.8125	100.0	200.0	BK568	120.00
27/32	MT2	0.8438	106.0	206.0	TBM169	147.00
7/8	MT2	0.8750	106.0	206.0	BK569	132.00
15/16	MT3	0.9375	114.0	241.0	BK570	201.00
31/32	MT3	0.9688	114.0	241.0	TBM170	233.00
1	MT3	1.0000	114.0	241.0	BK571	214.00
1 1/16	MT3	1.0625	124.0	251.0	BK572	252.00
1 1/8	MT3	1.1250	124.0	251.0	BK573	248.00
1 1/4	MT3	1.2500	133.0	260.0	BK574	322.00
1 3/8	MT4	1.3750	142.0	303.0	BK575	381.00
1 1/2	MT4	1.5000	152.0	312.0	BK576	475.00
1 5/8	MT4	1.6250	152.0	312.0	BK577	576.00
1 3/4	MT4	1.7500	163.0	323.0	BK578	674.00
1 7/8	MT4	1.8750	175.0	334.0	BK579	856.00
2	MT4	2.0000	175.0	334.0	BK580	852.00

METRIC SIZES

Metric Size mm	Morse Taper Shank Size	Decimal Equiv."	L2mm	L1mm	Model No.	Price /Each
3.00	MT1	0.1181	31.0	104.0	TBM145	50.90
3.50	MT1	0.1378	35.0	108.0	TBM146	64.00
4.00	MT1	0.1575	38.0	112.0	TBM149	51.70
4.50	MT1	0.1772	41.0	115.0	TBM151	60.20
5.00	MT1	0.1969	44.0	118.0	BK581	54.30
5.50	MT1	0.2165	48.0	125.0	TBM153	61.40
6.00	MT1	0.2362	48.0	125.0	BK582	55.50
6.50	MT1	0.2559	50.0	130.0	TBM155	63.60
7.00	MT1	0.2756	54.0	134.0	BK583	58.00
7.50	MT1	0.2953	54.0	134.0	TBM158	65.30
8.00	MT1	0.3150	58.0	138.0	BK584	58.00
8.50	MT1	0.3346	58.0	138.0	BK585	64.00
9.00	MT1	0.3543	62.0	141.0	BK586	58.50
9.50	MT1	0.3740	62.0	141.0	TBM162	72.90
10.00	MT1	0.3937	67.0	146.0	BK587	59.30
10.50	MT1	0.4134	67.0	146.0	BK588	69.50
11.00	MT1	0.4331	71.0	151.0	BK589	61.40
11.50	MT1	0.4528	71.0	151.0	BK590	70.80
12.00	MT1	0.4724	76.0	156.0	BK591	63.50
12.50	MT1	0.4921	76.0	156.0	BK592	71.20
13.00	MT1	0.5118	76.0	156.0	BK593	64.00
14.00	MT1	0.5512	81.0	160.0	BK594	71.60
15.00	MT2	0.5906	81.0	181.0	BK595	79.20
16.00	MT2	0.6299	87.0	187.0	BK596	87.80
17.00	MT2	0.6693	87.0	187.0	BK597	96.20

Metric Size mm	Morse Taper Shank Size	Decimal Equiv."	L2mm	L1mm	Model No.	Price /Each
18.00	MT2	0.7087	94.0	194.0	BK598	100.00
19.00	MT2	0.7480	94.0	194.0	BK599	113.00
20.00	MT2	0.7874	100.0	200.0	BK600	125.00
21.00	MT2	0.8268	100.0	200.0	BK601	133.00
22.00	MT2	0.8661	106.0	206.0	BK602	140.00
23.00	MT2	0.9055	106.0	206.0	BK603	143.00
24.00	MT3	0.9449	114.0	241.0	BK604	211.00
25.00	MT3	0.9843	114.0	241.0	BK605	212.00
26.00	MT3	1.0236	114.0	241.0	BK606	220.00
27.00	MT3	1.0630	124.0	251.0	BK607	244.00
28.00	MT3	1.1024	124.0	251.0	BK608	254.00
30.00	MT3	1.1811	124.0	251.0	BK609	271.00
32.00	MT4	1.2598	133.0	294.0	BK610	367.00
33.00	MT4	1.2992	133.0	294.0	TBM171	415.00
34.00	MT4	1.3386	142.0	303.0	BK611	424.00
35.00	MT4	1.3780	142.0	303.0	TBM172	451.00
36.00	MT4	1.4173	142.0	303.0	BK612	487.00
38.00	MT4	1.4961	152.0	312.0	BK613	526.00
40.00	MT4	1.5748	152.0	312.0	BK614	576.00
42.00	MT4	1.6535	152.0	312.0	BK615	648.00
44.00	MT4	1.7323	163.0	323.0	BK616	805.00
45.00	MT4	1.7717	163.0	323.0	BK617	764.00
46.00	MT4	1.8110	163.0	323.0	TBM173	860.00
48.00	MT4	1.8898	175.0	334.0	BK618	911.00
50.00	MT4	1.9685	175.0	334.0	TBM174	888.00

CHUCKING REAMERS (CONT'D)

LETTER GAUGE SIZES

Letter Size	Decimal Equiv.,"	L2"	L1"	Model No.	Price /Each
A	0.2340	1 1/2	6	BK270	29.60
B	0.2380	1 1/2	6	BK271	29.60
C	0.2420	1 1/2	6	BK272	29.60
D	0.2460	1 1/2	6	BK273	29.60
E	0.2500	1 1/2	6	BK169	24.30
F	0.2570	1 1/2	6	BK274	29.60
G	0.2610	1 1/2	6	BK275	31.60
H	0.2660	1 1/2	6	BK276	33.30
I	0.2720	1 1/2	6	BK277	33.30
J	0.2770	1 1/2	6	BK278	33.30
K	0.2810	1 1/2	6	BK279	33.30
L	0.2900	1 1/2	6	BK280	33.30
M	0.2950	1 1/2	6	BK281	33.30

Letter Size	Decimal Equiv.,"	L2"	L1"	Model No.	Price /Each
N	0.3020	1 1/2	6	BK282	33.30
O	0.3160	1 1/2	6	BK283	34.60
P	0.3230	1 1/2	6	BK284	35.50
Q	0.3320	1 1/2	6	BK285	35.50
R	0.3390	1 1/2	6	BK286	35.50
S	0.3480	1 3/4	7	BK287	35.50
T	0.3580	1 3/4	7	BK288	35.50
U	0.3680	1 3/4	7	BK289	35.50
V	0.3770	1 3/4	7	BK290	39.40
W	0.3860	1 3/4	7	BK291	39.40
X	0.3970	1 3/4	7	BK292	39.40
Y	0.4040	1 3/4	7	BK293	40.60
Z	0.4130	1 3/4	7	BK294	40.60

CHUCKING REAMERS - COBALT

- Right hand cut
- M42 Cobalt for hard steels & alloys
- Straight shank
- Spiral flute

Applications:

Spiral flute chucking reamers are designed for reaming materials where additional shear is necessary and to improve chip removal in blind holes. Ground with 45° chamfer.

FRACTIONAL SIZES

Fractional Size	Decimal Equiv.,"	L2mm	L1mm	Model No.	Price /Each
3/32	0.0938	14.0	57.0	BK371	63.50
1/8	0.1250	16.0	65.0	BK372	52.20
5/32	0.1563	19.0	75.0	BK373	51.30
11/64	0.1719	21.0	80.0	BK374	55.10
3/16	0.1875	23.0	86.0	BK375	52.20
7/32	0.2188	26.0	93.0	BK376	56.40
1/4	0.2500	28.0	101.0	BK377	59.30
9/32	0.2813	31.0	109.0	BK378	62.70
5/16	0.3125	33.0	117.0	BK379	66.60

METRIC SIZES

Metric Size	Decimal Equiv.,"	L2mm	L1mm	Model No.	Price /Each
3.00	0.1181	15.0	61.0	BK388	52.20
3.50	0.1378	18.0	70.0	BK389	44.50
4.00	0.1575	19.0	75.0	BK390	44.90
4.50	0.1772	21.0	80.0	BK391	50.90
5.00	0.1969	23.0	86.0	BK392	47.50
6.00	0.2362	26.0	93.0	BK393	55.90
7.00	0.2756	31.0	109.0	BK394	57.00
8.00	0.3150	33.0	117.0	BK395	63.10

Fractional Size	Decimal Equiv.,"	L2mm	L1mm	Model No.	Price /Each
11/32	0.3438	36.0	125.0	BK380	64.90
3/8	0.3750	38.0	133.0	BK381	75.40
13/32	0.4063	38.0	133.0	BK382	77.60
7/16	0.4375	41.0	142.0	BK383	87.70
15/32	0.4688	44.0	151.0	BK384	82.20
1/2	0.5000	44.0	151.0	BK385	82.20
9/16	0.5625	50.0	162.0	BK386	102.00
5/8	0.6250	52.0	170.0	BK387	107.00

Metric Size	Decimal Equiv.,"	L2mm	L1mm	Model No.	Price /Each
9.00	0.3543	36.0	125.0	BK396	66.10
10.00	0.3937	38.0	133.0	BK397	68.70
11.00	0.4331	41.0	142.0	BK398	80.10
12.00	0.4724	44.0	151.0	BK399	79.70
13.00	0.5118	44.0	151.0	BK400	84.30
14.00	0.5512	47.0	160.0	BK401	101.00
15.00	0.5906	50.0	162.0	BK402	108.00
16.00	0.6299	52.0	170.0	BK403	106.00

ADJUSTABLE HAND REAMERS

- High Speed Steel
- Right hand cutting direction

Applications:

Adjustable hand reamers are designed with enough adjustment to ream almost any odd size hole encountered in reaming. The blades are made of high speed steel for long life and can be adjusted by loosening one nut while tightening the other.

COMPLETE SETS

Adjustment From	Adjustment To	No. of Blades	L2 mm	L1 mm	Model No.	Price /Each
1/4	9/32	4	34.13	82.55	BK619	199.00
9/32	5/16	4	34.13	88.90	BK620	199.00
5/16	11/32	4	38.10	111.12	BK621	190.00
11/32	3/8	4	38.10	104.78	BK622	190.00
3/8	13/32	6	38.10	120.65	BK623	193.00
13/32	7/16	6	38.10	127.00	BK624	197.00
7/16	15/32	6	41.28	133.35	BK625	198.00
15/32	17/32	6	41.28	139.70	BK626	199.00
17/32	19/32	6	46.04	146.05	BK627	205.00
19/32	21/32	6	52.39	165.10	BK628	214.00
21/32	23/32	6	55.56	171.45	BK629	217.00
23/32	25/32	6	66.50	177.80	BK630	235.00
25/32	27/32	6	66.68	187.32	BK631	243.00
27/32	15/16	6	76.20	203.20	BK632	269.00
15/16	1 1/16	6	82.55	228.60	BK633	312.00
1 1/16	1 3/16	6	85.72	254.00	BK634	365.00
1 3/16	1 11/32	6	98.42	279.40	BK635	444.00
1 11/32	1 1/2	6	107.95	304.80	BK636	514.00
1 1/2	1 13/16	6	112.71	355.60	BK637	623.00
1 13/16	2 7/32	6	123.83	406.40	BK638	904.00
2 7/32	2 3/4	6	127.00	457.20	TBM096	1527.00
2 3/4	3 11/32	6	133.35	508.00	TBM097	2080.00

CLARKSON OSBORN

REPLACEMENT PARTS

Blade Set Model No.	Price /Each	Pilot Model No.	Price /Each	Nut Model No.	Price /Each
BK639	94.40	TBM296	143.00	TBM300	15.30
BK640	94.40	TBM297	143.00	TBM301	15.30
BK641	94.40	TBM298	140.00	TBM302	15.30
BK642	94.40	TBM299	140.00	TBM303	15.30
BK643	100.00	TBM106	109.00	TBM125	16.40
BK644	108.00	TBM107	111.00	TBM126	16.40
BK645	109.00	TBM108	112.00	TBM127	17.40
TBM098	111.00	TBM109	113.00	TBM128	17.40
TBM099	115.00	TBM110	114.00	TBM129	18.20
BK646	124.00	TBM111	116.00	TBM130	21.10
TBM100	127.00	TBM112	133.00	TBM131	21.10
TBM101	145.00	TBM113	134.00	TBM132	22.10
TBM102	150.00	TBM114	139.00	TBM133	22.10
BK647	163.00	TBM115	148.00	TBM134	23.10
BK648	207.00	TBM116	149.00	TBM135	25.00
BK649	231.00	TBM117	172.00	TBM136	25.00
BK650	280.00	TBM118	178.00	TBM137	30.70
BK651	329.00	TBM119	206.00	TBM138	33.70
BK652	363.00			TBM139	43.70
TBM103	528.00	TBM121	386.00	TBM140	49.90
TBM104	749.00	TBM122	652.00	TBM141	97.40
TBM105	981.00	TBM123	809.00	TBM142	143.00

CUTTING TOOLS

WELDON SHANK END MILLS - STANDARD LENGTH - 2 FLUTE



CLARKSON  OSBORN

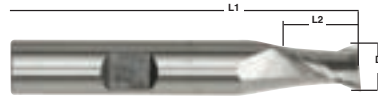

D1 Frac"	Shank Dec"	Dia. "	L2 "	L1 "	Flutes	HSS Model No.	HSS Price/Each	Cobalt Model No.	Cobalt Price/Each
1/8	0.1250	3/8	3/8	2 5/16	2	BI291	-	BI161	20.50
5/32	0.1563	3/8	7/16	2 5/16	2	BI292	11.80	BI162	24.20
3/16	0.1875	3/8	7/16	2 5/16	2	QD764	11.80	BI163	20.50
7/32	0.2188	3/8	1/2	2 5/16	2	BI293	11.80	BI164	24.20
1/4	0.2500	3/8	1/2	2 5/16	2	QD765	11.80	BI165	20.50
9/32	0.2813	3/8	9/16	2 5/16	2	QD766	11.80	-	-
5/16	0.3125	3/8	9/16	2 5/16	2	-	-	BI166	20.50
11/32	0.3438	3/8	9/16	2 5/16	2	QD768	11.80	-	-
3/8	0.3750	3/8	9/16	2 5/16	2	QD769	11.80	BI167	20.50
13/32	0.4063	3/8	13/16	2 1/2	2	BI294	18.00	-	-
7/16	0.4375	3/8	13/16	2 1/2	2	QR042	18.00	BI168	30.30
15/32	0.4688	3/8	13/16	2 1/2	2	BI295	18.00	-	-
1/2	0.5000	3/8	13/16	2 1/2	2	-	-	BI169	32.80
1/2	0.5000	1/2	1	3	2	QD771	18.00	BI170	30.10
17/32	0.5313	1/2	1 1/8	3 1/8	2	BI296	27.00	-	-
9/16	0.5625	1/2	1 1/8	3 1/8	2	QR043	27.00	BI171	41.70
19/32	0.5938	5/8	1 1/8	3 1/8	2	BI297	33.70	-	-
5/8	0.6250	1/2	1 1/8	3 1/8	2	-	-	BI172	46.00
5/8	0.6250	5/8	1 5/16	3 7/16	2	QR044	33.70	BI173	44.40
21/32	0.6563	5/8	1 5/16	3 7/16	2	BI298	39.40	-	-
11/16	0.6875	5/8	1 5/16	3 7/16	2	QR045	39.40	BI174	52.10

D1 Frac"	Shank Dec"	Dia. "	L2 "	L1 "	Flutes	HSS Model No.	HSS Price/Each	Cobalt Model No.	Cobalt Price/Each
23/32	0.7188	3/4	1 5/16	3 7/16	2	BI301	43.80	-	-
3/4	0.7500	5/8	1 5/16	3 7/16	2	-	-	BI175	54.40
3/4	0.7500	3/4	1 5/16	3 7/16	2	QR046	43.80	BI176	52.10
25/32	0.7813	5/8	1 1/2	3 5/8	2	BI299	47.80	-	-
13/16	0.8125	5/8	1 1/2	3 5/8	2	BI300	47.80	-	-
27/32	0.8438	3/4	1 1/2	3 3/4	2	BI302	50.60	-	-
7/8	0.8750	3/4	1 1/2	3 3/4	2	BI303	50.60	BI177	66.50
7/8	0.8750	7/8	1 1/2	3 3/4	2	BI306	50.60	BI179	69.00
29/32	0.9063	7/8	1 1/2	3 3/4	2	BI307	65.20	-	-
15/16	0.9375	7/8	1 1/2	3 3/4	2	BI308	65.20	-	-
31/32	0.9688	3/4	1 1/2	3 3/4	2	BI304	65.20	-	-
1	1.0000	3/4	1 1/2	3 3/4	2	BI305	65.20	BI178	82.60
1	1.0000	1	1 5/8	4 1/8	2	-	-	BI180	78.90
1 1/8	1.1250	1	1 5/8	4 1/8	2	BI310	95.20	-	-
1 1/4	1.2500	1	1 5/8	4 1/8	2	-	-	BI181	140.00
1 1/4	1.2500	1 1/4	1 5/8	4 1/8	2	BI311	103.00	BI183	133.00
1 3/8	1.3750	1 1/4	1 5/8	4 1/8	2	BI312	128.00	-	-
1 1/2	1.5000	1	1 5/8	4 1/8	2	-	-	BI182	172.00
1 1/2	1.5000	1 1/4	1 5/8	4 1/8	2	BI313	152.00	BI184	172.00
1 3/4	1.7500	1 1/4	1 5/8	4 1/8	2	BI314	196.00	-	-
2	2.0000	1 1/4	1 5/8	4 1/8	2	BI315	229.00	-	-

WELDON SHANK SLOT DRILLS - STANDARD LENGTH - 2 FLUTE

CLARKSON  OSBORN

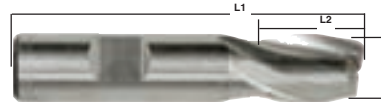

D1 mm	Shank Dec"	Dia. mm	L2 mm	L1 mm	Flutes	Cobalt Model No.	Cobalt Price/Each
1.5	0.0591	6.0	3.0	48.0	2	BJ582	38.20
2.0	0.0787	6.0	4.0	48.0	2	BJ583	29.30
2.5	0.0984	6.0	5.0	59.0	2	BJ584	35.40
3.0	0.1181	6.0	5.0	49.0	2	BJ585	29.30
3.5	0.1378	6.0	6.0	50.0	2	BJ586	35.40
4.0	0.1575	6.0	7.0	51.0	2	BJ587	29.30
4.5	0.1772	6.0	7.0	51.0	2	BJ588	35.40
5.0	0.1969	6.0	8.0	52.0	2	BJ589	31.70
5.5	0.2165	6.0	8.0	52.0	2	BJ590	35.40
6.0	0.2362	6.0	8.0	52.0	2	BJ591	31.70
6.5	0.2559	10.0	10.0	60.0	2	BJ592	47.60
7.0	0.2756	10.0	10.0	60.0	2	BJ593	33.80
7.5	0.2953	10.0	10.0	60.0	2	BJ594	47.60
8.0	0.3150	10.0	11.0	61.0	2	BJ595	33.80
8.5	0.3346	10.0	11.0	61.0	2	BJ596	49.00
9.0	0.3543	10.0	11.0	61.0	2	BJ597	39.40
9.5	0.3740	10.0	11.0	61.0	2	BJ598	49.00
10.0	0.3937	10.0	13.0	63.0	2	BJ599	33.80
10.5	0.4134	12.0	13.0	70.0	2	BJ600	56.60
11.0	0.4331	12.0	13.0	70.0	2	BJ601	46.60

D1 mm	Shank Dec"	Dia. mm	L2 mm	L1 mm	Flutes	Cobalt Model No.	Cobalt Price/Each
12.0	0.4724	12.0	16.0	73.0	2	BJ602	42.10
13.0	0.5118	12.0	16.0	73.0	2	BJ603	78.40
14.0	0.5512	12.0	16.0	73.0	2	BJ604	48.60
15.0	0.5906	12.0	16.0	73.0	2	BJ605	78.40
16.0	0.6299	16.0	19.0	79.0	2	BJ606	58.70
18.0	0.7087	16.0	19.0	79.0	2	BJ607	66.10
20.0	0.7874	20.0	22.0	88.0	2	BJ608	78.60
22.0	0.8661	20.0	22.0	88.0	2	BJ609	97.90
24.0	0.9449	25.0	26.0	102.0	2	BJ610	117.00
25.0	0.9843	25.0	26.0	102.0	2	BJ611	122.00
26.0	1.0236	25.0	26.0	102.0	2	BJ612	135.00
28.0	1.1024	25.0	26.0	102.0	2	BJ613	135.00
30.0	1.1811	25.0	26.0	102.0	2	BJ614	138.00
32.0	1.2598	32.0	32.0	112.0	2	BJ615	165.00
36.0	1.4173	32.0	32.0	112.0	2	BJ616	228.00
38.0	1.4961	32.0	38.0	120.0	2	BJ617	287.00
40.0	1.5748	32.0	38.0	120.0	2	BJ618	287.00
45.0	1.7717	32.0	38.0	120.0	2	BJ619	430.00
50.0	1.9685	32.0	45.0	137.0	2	BJ620	573.00

WELDON SHANK SLOT DRILLS

CLARKSON  OSBORN

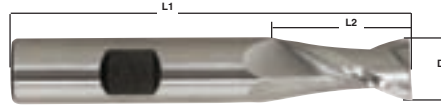

2 FLUTE - COBALT - KEYWAY TOLERANCE

D1 +0.000/-0.015"	DEC"	Shank Dia. "	L2 "	L1 "	Flutes	Model No.	Price /Each
1/8	0.1250	3/8	3/8	2.5/16	2	BI136	13.90
5/32	0.1563	3/8	7/16	2.5/16	2	BI137	13.90
3/16	0.1875	3/8	7/16	2.5/16	2	BI138	13.90
7/32	0.2188	3/8	1/2	2.5/16	2	BI139	13.90
1/4	0.2500	3/8	1/2	2.5/16	2	BI140	13.90
9/32	0.2813	3/8	9/16	2.5/16	2	BI141	13.90
5/16	0.3125	3/8	9/16	2.5/16	2	BI142	13.90
11/32	0.3438	3/8	9/16	2.5/16	2	BI143	13.90
3/8	0.3750	3/8	9/16	2.5/16	2	BI144	13.90
13/32	0.4063	3/8	13/16	2 1/2	2	BI145	21.10
7/16	0.4375	3/8	13/16	2 1/2	2	BI146	21.10
15/32	0.4688	3/8	13/16	2 1/2	2	BI147	21.10
1/2	0.5000	1/2	1	3	2	BI148	21.10

D1 +0.000/-0.015"	DEC"	Shank Dia. "	L2 "	L1 "	Flutes	Model No.	Price /Each
9/16	0.5625	1/2	1 1/8	3 1/8	2	BI149	31.50
5/8	0.6250	5/8	1 5/16	3 7/16	2	BI150	37.40
11/16	0.6875	5/8	1 5/16	3 7/16	2	BI151	43.70
3/4	0.7500	3/4	1 5/16	3 7/16	2	BI152	48.70
13/16	0.8125	5/8	1 1/2	3 5/8	2	BI153	53.10
7/8	0.8750	3/4	1 1/2	3 3/4	2	BI154	56.20
1	1.0000	1	1 5/8	4 1/8	2	BI155	56.20
1 1/8	1.1250	1	1 5/8	4 1/8	2	BI156	116.00
1 1/4	1.2500	1 1/4	1 5/8	4 1/8	2	BI157	126.00
1 1/2	1.5000	1 1/4	1 5/8	4 1/8	2	BI158	188.00
1 3/4	1.7500	1 1/4	1 5/8	4 1/8	2	BI159	240.00
2	2.0000	1 1/4	1 5/8	4 1/8	2	BI160	282.00

WELDON SHANK 3 FLUTE SUPERMILLS

CLARKSON  OSBORN



D1 mm	DEC"	Shank Dia. mm	L2 mm	L1 mm	Flutes	Cobalt Model No.	Cobalt Price/Each
3.0	0.1181	6.0	8.0	52.0	3	BJ664	37.30
3.5	0.1378	6.0	10.0	54.0	3	TBL877	38.70
4.0	0.1575	6.0	11.0	55.0	3	BJ665	37.30
4.5	0.1772	6.0	11.0	55.0	3	TBL878	38.70
5.0	0.1969	6.0	13.0	57.0	3	BJ666	37.30
5.5	0.2165	6.0	13.0	57.0	3	TBL879	38.70
6.0	0.2362	6.0	13.0	57.0	3	BJ667	37.30
8.0	0.3150	10.0	19.0	69.0	3	BJ668	42.90
10.0	0.3937	10.0	22.0	72.0	3	BJ669	57.00
12.0	0.4724	12.0	26.0	83.0	3	BJ670	57.40
14.0	0.5512	12.0	26.0	83.0	3	BJ671	72.30
16.0	0.6299	16.0	32.0	92.0	3	BJ672	89.40
18.0	0.7087	16.0	32.0	92.0	3	BJ673	114.00
20.0	0.7874	20.0	38.0	104.0	3	TBL880	121.00
22.0	0.8661	20.0	38.0	104.0	3	BJ674	163.00
24.0	0.9449	25.0	45.0	121.0	3	TBL881	198.00
25.0	0.9843	25.0	45.0	121.0	3	BJ675	194.00
26.0	1.0236	25.0	45.0	121.0	3	TBL882	239.00
28.0	1.1024	25.0	45.0	121.0	3	BJ676	250.00
30.0	1.1811	25.0	45.0	121.0	3	BJ677	284.00
32.0	1.2598	32.0	53.0	133.0	3	BJ678	325.00
40.0	1.5748	32.0	63.0	143.0	3	TBL883	574.00
50.0	1.9685	32.0	75.0	155.0	3	TBL884	798.00

LONG SERIES

D1 mm	DEC"	Shank Dia. mm	L2 mm	L1 mm	Flutes	Cobalt Model No.	Cobalt Price/Each
3.0	0.1181	6.0	12.0	56.0	3	TBL885	45.90
4.0	0.1575	6.0	19.0	63.0	3	BJ680	45.90
5.0	0.1969	6.0	24.0	68.0	3	TBL886	45.90
6.0	0.2362	6.0	24.0	68.0	3	TBL887	45.90
8.0	0.3150	10.0	38.0	88.0	3	TBL888	69.40
10.0	0.3937	10.0	45.0	95.0	3	BJ683	68.60
12.0	0.4724	12.0	53.0	110.0	3	TBL889	77.10
14.0	0.5512	12.0	53.0	110.0	3	TBL890	107.00
16.0	0.6299	16.0	63.0	123.0	3	TBL891	124.00
18.0	0.7087	16.0	63.0	123.0	3	TBL892	159.00
20.0	0.7874	20.0	75.0	135.0	3	TBL893	162.00
22.0	0.8661	20.0	75.0	147.0	3	TBL894	272.00
24.0	0.9449	25.0	90.0	166.0	3	TBL895	290.00
25.0	0.9843	25.0	90.0	166.0	3	TBL896	301.00
28.0	1.1024	25.0	90.0	166.0	3	TBL897	362.00
30.0	1.1811	25.0	90.0	166.0	3	TBL898	389.00



KLETON

Canada's Leading Material Handling Supplier



CUTTING TOOLS

ENDMILLS

SOLID CARBIDE – SQUARE END

- Solid micro-grain carbide
- Available in 2, 3 and 4-flute models
- Right-hand cutting direction
- Centre cut - designed to plunge cut or drill to depth and then mill sideways into work
- Bright finish

Applications:

For machining tough work hardening metals, stainless steel, titanium, monel, inconel, and super alloys.

CLARKSON OSBORN



Fractional Size"	Decimal Equiv"	Shank Ø	Overall L1"	Flute L2"	2-Flute Model No.	Price /Each	3-Flute Model No.	Price /Each	4-Flute Model No.	Price /Each
1/32	0.0313	1/8	5/64	1 1/2	BK909	19.50	-	-	BK966	19.50
3/64	0.0469	1/8	7/64	1 1/2	BK910	19.50	-	-	BK967	19.50
1/16	0.0625	1/8	3/16	1 1/2	BK911	15.90	BK947	15.90	BK968	15.90
5/64	0.0781	1/8	3/16	1 1/2	BK912	15.90	TBM176	15.90	BK969	15.90
3/32	0.0938	1/8	9/32	1 1/2	BK913	15.90	BK948	15.90	BK970	15.90
7/64	0.1094	1/8	3/8	1 1/2	BK914	15.90	TBM177	15.90	BK971	15.90
1/8	0.1250	1/8	1/2	1 1/2	BK915	15.90	BK949	15.90	BK972	15.90
9/64	0.1406	3/16	1/2	2	BK916	21.80	TBM178	21.80	BK973	21.80
5/32	0.1563	3/16	1/2	2	BK917	21.80	BK950	21.80	BK974	21.80
11/64	0.1719	3/16	5/8	2	BK918	22.40	BK951	22.40	BK975	22.40
3/16	0.1875	3/16	5/8	2	BK919	22.40	BK952	22.40	BK976	22.40
13/64	0.2031	1/4	5/8	2 1/2	BK920	27.50	TBM179	27.50	BK977	27.50
7/32	0.2188	1/4	5/8	2 1/2	BK921	27.50	BK953	27.50	BK978	27.50
15/64	0.2344	1/4	3/4	2 1/2	BK922	28.80	BK954	28.80	BK979	28.80
1/4	0.2500	1/4	3/4	2 1/2	BK923	28.80	BK955	28.80	BK980	28.80
17/64	0.2656	5/16	3/4	2 1/2	BK924	31.10	TBM180	31.10	BK981	31.10
9/32	0.2813	5/16	3/4	2 1/2	BK925	31.10	TBM181	31.10	BK982	31.10
19/64	0.2969	5/16	13/16	2 1/2	BK926	32.40	TBM182	32.40	BK983	32.40
5/16	0.3125	5/16	13/16	2 1/2	BK927	32.40	BK956	32.40	BK984	32.40
21/64	0.3281	3/8	1	2 1/2	BK928	41.00	-	-	BK985	41.00
11/32	0.3438	3/8	1	2 1/2	BK929	41.00	TBM184	41.00	BK986	41.00
23/64	0.3594	3/8	1	2 1/2	BK930	41.00	TBM185	41.00	BK987	41.00
3/8	0.3750	3/8	1	2 1/2	BK931	41.00	BK957	41.00	BK988	41.00
25/64	0.3906	7/16	1	2 3/4	TBM175	60.30	TBM186	60.30	TBM193	60.30
13/32	0.4063	7/16	1	2 3/4	BK932	60.30	BK958	60.30	BK989	60.30
27/64	0.4219	7/16	1	2 3/4	BK933	60.30	TBM187	60.30	TBM194	60.30
7/16	0.4375	7/16	1	2 3/4	BK934	60.30	BK959	60.30	BK990	60.30
29/64	0.4531	1/2	1	3	BK935	70.10	TBM188	70.10	TBM195	70.10
15/32	0.4688	1/2	1	3	BK936	70.10	TBM189	70.10	BK991	70.10
31/64	0.4844	1/2	1	3	BK937	70.10	TBM190	70.10	TBM196	70.10
1/2	0.5000	1/2	1	3	BK938	70.10	BK960	70.10	BK992	70.10
9/16	0.5625	9/16	1 1/8	3 1/2	BK939	119.00	TBM191	119.00	BK993	119.00
5/8	0.6250	5/8	1 1/4	3 1/2	BK940	133.00	BK961	133.00	BK994	133.00
11/16	0.6875	3/4	1 3/8	4	BK941	196.00	TBM192	196.00	BK995	196.00
3/4	0.7500	3/4	1 1/2	4	BK942	196.00	BK962	196.00	BK996	196.00
7/8	0.8750	7/8	1 1/2	4	BK943	340.00	BK963	340.00	BK997	340.00
1	1.0000	1	1 1/2	4	BK944	348.00	BK964	348.00	BK998	348.00

SOLID CARBIDE – BALL END

- Solid micro-grain carbide
- Available in 2, 3 and 4-flute models
- Right-hand cutting direction
- Centre cut - designed to plunge cut or drill to depth and then mill sideways into work
- Bright finish

Applications:

for machining tough work hardening metals, stainless steel, titanium, monel, inconel, and super alloys

CLARKSON OSBORN



Fractional Size"	Decimal Equiv"	Shank Ø	Overall L1"	Flute L2"	2-Flute Model No.	Price /Each	3-Flute Model No.	Price /Each	4-Flute Model No.	Price /Each
1/32	0.0313	1/8	5/64	1 1/2	BL001	23.40	-	-	BL044	23.40
3/64	0.0469	1/8	7/64	1 1/2	BL002	23.40	-	-	BL045	23.40
1/16	0.0625	1/8	3/16	1 1/2	BL003	19.10	BL033	19.10	BL046	19.10
5/64	0.0781	1/8	3/16	1 1/2	BL004	19.10	TBM203	19.10	BL047	19.10
3/32	0.0938	1/8	9/32	1 1/2	BL005	19.10	BL034	19.10	BL048	19.10
7/64	0.1094	1/8	3/8	1 1/2	BL006	19.10	TBM204	19.10	BL049	19.10
1/8	0.1250	1/8	1/2	1 1/2	BL007	19.10	BL035	19.10	BL050	19.10
9/64	0.1406	3/16	1/2	2	BL008	23.60	TBM205	23.60	BL051	23.60
5/32	0.1563	3/16	1/2	2	BL009	26.20	BL036	26.20	BL052	26.20
11/64	0.1719	3/16	5/8	2	BL010	27.00	TBM206	27.00	TBM223	27.00
3/16	0.1875	3/16	5/8	2	BL011	27.00	BL037	27.00	BL053	27.00
13/64	0.2031	1/4	5/8	2 1/2	BL012	32.90	TBM207	32.90	BL054	32.90
7/32	0.2188	1/4	5/8	2 1/2	BL013	32.90	TBM208	32.90	BL055	32.90
15/64	0.2344	1/4	3/4	2 1/2	BL014	34.60	TBM209	34.60	TBM224	34.60
1/4	0.2500	1/4	3/4	2 1/2	BL015	34.60	BL038	34.60	BL056	34.60
17/64	0.2656	5/16	3/4	2 1/2	BL016	36.70	TBM210	36.70	BL057	36.70
9/32	0.2813	5/16	3/4	2 1/2	BL017	36.70	TBM211	36.70	BL058	36.70
19/64	0.2969	5/16	13/16	2 1/2	BL018	38.90	TBM212	38.90	TBM225	38.90
5/16	0.3125	5/16	13/16	2 1/2	BL019	38.90	BL039	38.90	BL059	38.90
21/64	0.3281	3/8	1	2 1/2	BL020	48.90	TBM213	48.90	TBM226	48.90
11/32	0.3438	3/8	1	2 1/2	BL021	49.30	TBM214	49.30	BL060	49.30
23/64	0.3594	3/8	1	2 1/2	TBM197	49.30	TBM215	49.30	TBM227	49.30
3/8	0.3750	3/8	1	2 1/2	BL022	49.30	BL040	49.30	BL061	49.30
25/64	0.3906	7/16	1	2 3/4	TBM198	72.40	TBM216	72.40	TBM228	72.40
13/32	0.4063	7/16	1	2 3/4	BL023	72.40	TBM217	72.40	BL062	72.40
27/64	0.4219	7/16	1	2 3/4	TBM199	72.40	TBM218	72.40	TBM229	72.40
7/16	0.4375	7/16	1	2 3/4	BL024	72.40	BL041	72.40	BL063	72.40
29/64	0.4531	1/2	1	3	TBM200	84.10	TBM219	84.10	TBM230	84.10
15/32	0.4688	1/2	1	3	BL025	84.10	TBM220	84.10	TBM231	84.10
31/64	0.4844	1/2	1	3	BL026	84.10	TBM221	84.10	TBM232	84.10
1/2	0.5000	1/2	1	3	BL027	84.10	BL042	84.10	BL064	84.10
9/16	0.5625	9/16	1 1/8	3 1/2	BL028	143.00	TBM222	143.00	BL065	143.00
5/8	0.6250	5/8	1 1/4	3 1/2	BL029	160.00	-	-	BL066	160.00
11/16	0.6875	3/4	1 3/8	4	TBM201	236.00	-	-	TBM233	236.00
3/4	0.7500	3/4	1 1/2	4	BL030	236.00	-	-	BL067	236.00
7/8	0.8750	7/8	1 1/2	4	TBM202	408.00	-	-	BL068	408.00
1	1.0000	1	1 1/2	4	BL031	417.00	-	-	BL069	417.00

ENDMILLS

SOLID CARBIDE – SQUARE END

- Solid micro-grain carbide
- Available in 2 and 4-flute models
- Right-hand cutting direction
- Centre cut - designed to plunge cut or drill to depth and then mill sideways into work
- Bright finish

LONG LENGTH SERIES

Cutting Ø	Shank Ø"	L1"	L"	2-Flute Model No.	Price /Each	4-Flute Model No.	Price /Each
1/8	0.1250	3/4	2 1/4	TBM252	25.30	BL078	25.30
3/16	0.1875	3/4	2 1/4	BL070	29.00	BL079	29.00
1/4	0.2500	1 1/8	3	BL071	36.00	BL080	36.00
5/16	0.3125	1 1/8	3	BL072	56.40	BL081	56.40
3/8	0.3750	1 1/8	3	BL073	56.40	BL082	56.40
7/16	0.4375	2	4 1/2	BL074	89.60	BL083	89.60
1/2	0.5000	2	4 1/2	BL075	102.00	BL084	102.00
5/8	0.6250	2 1/4	5	BL076	191.00	BL085	191.00
3/4	0.7500	2 1/4	5	BL077	247.00	BL086	247.00
1	1.0000	2 1/4	5	TBM253	495.00	BL087	495.00

SOLID CARBIDE – BALL END

- Solid micro-grain carbide
- Available in 2 and 4-flute models
- Right-hand cutting direction
- Centre cut - designed to plunge cut or drill to depth and then mill sideways into work
- Bright finish

LONG LENGTH SERIES

Cutting Ø	Shank Ø	L1"	L"	2-Flute Model No.	Price /Each	4-Flute Model No.	Price /Each
1/8	0.1250	3/4	2 1/4	TBM265	30.40	TBM268	30.40
3/16	0.1875	3/4	2 1/2	BL088	34.80	TBM269	34.80
1/4	0.2500	1 1/8	3	BL089	43.20	BL095	43.20
5/16	0.3125	1 1/8	3	BL090	53.50	BL096	53.50
3/8	0.3750	1 1/8	3	BL091	67.80	BL097	67.80
7/16	0.4375	2	4 1/2	TBM266	107.00	BL098	107.00
1/2	0.5000	2	4 1/2	BL092	122.00	BL099	122.00
5/8	0.6250	2 1/4	5	BL093	229.00	TBM270	229.00
3/4	0.7500	2 1/4	5	BL094	296.00	TBM271	296.00
1	1.0000	2 1/4	5	TBM267	594.00	BL100	594.00

SCREW EXTRACTORS

- Left-hand cut
- High speed steel
- Punch point
- Spiral flute

Applications:

Remove broken screws, bolts, studs, pipe and lubrication fittings without damage to the threaded hole. Designed with a left-hand helical flute to firmly grip and remove any right hand threaded screw or bolt from 3/16" to 1 3/4" in size.

Size No.	Drill Size to Use"	For Screw /Bolt Sizes"	Model No.	Price /Each
#1	5/64	3/16 to 1/4	BM708	7.68
#2	7/64	1/4 to 5/16	BM709	8.44
#3	5/32	5/16 to 7/16	BM710	9.84
#4	1/4	7/16 to 9/16	BM711	10.30
#5	17/64	9/16 to 3/4	BM712	13.90
#6	13/32	3/4 to 1"	BM713	19.10
#7	17/32	1-1 3/8	BM714	30.00
#8	13/16	1 3/8 to 1 3/4	BM715	46.20

SETS

	Model No.	Price /Each
5-piece set, includes extractor #1 to #5	BM716	51.40
6-piece set, includes extractor #1 to #6	BM717	69.00
8-piece set, includes extractor #1 to #8	BM718	152.00

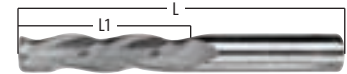

EXTRA LONG LENGTH

Cutting Ø	Shank Ø	L1"	L"	2-Flute Model No.	Price /Each	4-Flute Model No.	Price /Each
1/8	0.1250	1	3	TBM248	29.60	TBM250	29.60
3/16	0.1875	1 1/8	3	BL101	34.80	BL109	34.80
1/4	0.2500	1 1/2	4	BL102	43.20	BL110	43.20
5/16	0.3125	1 5/8	4	BL103	53.50	BL111	53.50
3/8	0.3750	1 3/4	4	BL104	73.20	BL112	73.20
7/16	0.4375	3	6	TBM249	128.00	TBM251	128.00
1/2	0.5000	3	6	BL105	169.00	BL113	169.00
5/8	0.6250	3	6	BL106	277.00	BL114	277.00
3/4	0.7500	3	6	BL107	347.00	BL115	347.00
1	1.0000	3	6	BL108	554.00	BL116	554.00



EXTRA LONG LENGTH

Cutting Ø	Shank Ø	L1"	L"	2-Flute Model No.	Price /Each	4-Flute Model No.	Price /Each
1/8	0.1250	1	3	TBM254	38.80	TBM260	38.80
3/16	0.1875	1 1/8	3	BL117	42.70	BL121	42.70
1/4	0.2500	1 1/2	4	BL118	51.80	BL122	51.80
5/16	0.3125	1 5/8	4	TBM255	63.30	BL123	63.30
3/8	0.3750	1 3/4	4	TBM256	87.90	BL124	87.90
7/16	0.4375	3	6	TBM257	154.00	TBM261	154.00
1/2	0.5000	3	6	BL119	202.00	BL125	202.00
5/8	0.6250	3	6	TBM258	333.00	TBM262	333.00
3/4	0.7500	3	6	BL120	417.00	TBM263	417.00
1	1.0000	3	6	TBM259	665.00	TBM264	665.00

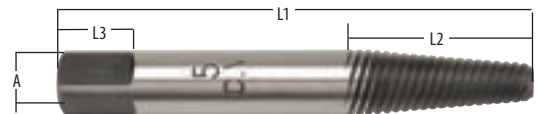

BM718

CUTTING TOOLS

SOLID CARBIDE BURRS - 1/4" SHANK

SC90 DOUBLE CUT

- 1/4" shank
- Double cut
- Ideal for extra tough materials
- Excellent control allows for clean finish



CYLINDER SHAPE

Model No.	Mfg. No.	No.	Head Dia.™	Flute Length™	Price /Each
BL240	SC90002	SA-12	1/8	5/8	18.10
BL241	SC90003	SA-13	5/32	5/8	18.10
BL242	SC90004	SA-14	3/16	5/8	18.10
BL243	SC90005	SA-1	1/4	5/8	18.10
BL244	SC90006	SA-1L	1/4	1	26.30
BL245	SC90007	SA-2	5/16	3/4	23.70
BL246	SC90008	SA-3	3/8	3/4	25.60
BL247	SC90009	SA-3L	3/8	1	30.30
BL248	SC90010	SA-3X	3/8	1 1/2	33.60
BL249	SC90011	SA-4	7/16	1	36.90
BL250	SC90012	SA-5	1/2	1	39.80
BL251	SC90013	SA-6	5/8	1	50.10
BL252	SC90014	SA-7	3/4	1	74.60
BL253	SC90015	SA-15	3/4	1/2	67.90
BL254	SC90016	SA-16	3/4	3/4	74.60
BL255	SC90017	SA-8	7/8	1	93.90
BL256	SC90018	SA-9	1	1	104.00

CYLINDER SHAPE WITH END CUT



Model No.	Mfg. No.	No.	Head Dia.™	Flute Length™	Price /Each
BL258	SC90020	SB-12	1/8	5/8	19.70
BL259	SC90021	SB-13	5/32	5/8	19.70
BL260	SC90022	SB-14	3/16	5/8	19.70
BL261	SC90023	SB-1	1/4	5/8	19.70
BL262	SC90024	SB-1L	1/4	1	29.10
BL263	SC90025	SB-2	5/16	3/4	26.10
BL264	SC90026	SB-3	3/8	3/4	28.00
BL265	SC90027	SB-3L	3/8	1	33.40
BL266	SC90028	SB-3X	3/8	1 1/2	34.90
BL267	SC90029	SB-4	7/16	1	40.80
BL268	SC90030	SB-5	1/2	1	43.80
BL269	SC90031	SB-6	5/8	1	55.00
BL270	SC90032	SB-7	3/4	1	82.10
BL271	SC90033	SB-15	3/4	1/2	74.60
BL272	SC90034	SB-16	3/4	3/4	82.10
BL273	SC90035	SB-8	7/8	1	103.00
BL274	SC90036	SE-9	1	1	115.00

SOLID CARBIDE BURRS - 1/4" X 6" LONG SHANK

SC90 DOUBLE CUT

- 6" overall length
- 1/4" shank
- Double cut
- Ideal for extra tough materials
- Excellent control allows for clean finish

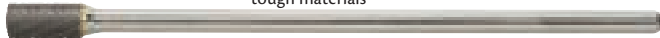

CYLINDER SHAPE

Model No.	Mfg. No.	No.	Head Dia.™	Flute Length™	Price/Each
BL422	SC90601	SA-1L6	1/4	1/2	23.70
BL423	SC90602	SA-3L6	3/8	3/4	23.70
BL424	SC90603	SA-5L6	1/2	1	28.40



CYLINDER SHAPE WITH RADIUS END

Model No.	Mfg. No.	No.	Head Dia.™	Flute Length™	Price/Each
BL425	SC90604	SC-1L6	1/4	1/2	29.50
BL426	SC90605	SC-3L6	3/8	3/4	39.70
BL427	SC90606	SC-5L6	1/2	1	62.40



BALL SHAPE

Model No.	Mfg. No.	No.	Head Dia.™	Flute Length™	Price/Each
BL428	SC90607	SD-1L6	1/4	3/16	27.20
BL429	SC90608	SD-3L6	3/8	5/16	32.70
BL430	SC90609	SD-5L6	1/2	7/16	44.00



OVAL SHAPE

Model No.	Mfg. No.	No.	Head Dia.™	Flute Length™	Price/Each
BL431	SC90610	SE-1L6	1/4	3/8	32.80
BL432	SC90611	SE-3L6	3/8	5/8	39.70
BL433	SC90612	SE-5L6	1/2	7/8	58.10

CYLINDER SHAPE WITH RADIUS END



Model No.	Mfg. No.	No.	Head Dia.™	Flute Length™	Price /Each
BL275	SC90037	SC-11	1/8	1/2	21.10
BL276	SC90038	SC-12	1/8	5/8	21.10
BL277	SC90039	SC-3	5/32	5/8	21.10
BL278	SC90040	SC-14	3/16	5/8	21.10
BL279	SC90041	SC-1	1/4	5/8	21.10
BL280	SC90042	SC-1L	1/4	1	28.80
BL281	SC90043	SC-2	5/16	3/4	25.90
BL282	SC90044	SC-3	3/8	3/4	28.40
BL283	SC90045	SC-3L	3/8	1	33.50
BL284	SC90046	SC-3X	3/8	1 1/2	36.70
BL285	SC90047	SC-4	7/16	1	40.50
BL286	SC90048	SC-5	1/2	1	44.60
BL287	SC90049	SC-6	5/8	1	56.20
BL288	SC90050	SC-7	3/4	1	80.60
TBM293	SC90051	SC-15	3/4	1/2	73.40
BL289	SC90052	SC-16	3/4	3/4	80.60
BL290	SC90053	SSC-9	1	1	122.00

CLARKSON OSBORN



BALL SHAPE

Model No.	Mfg. No.	No.	Head Dia.™	Flute Length™	Price /Each
BL291	SC90054	SD-11	1/8	3/32	19.40
BL292	SC90055	SD-14	3/16	1/8	19.40
BL293	SC90056	SD-1	1/4	3/16	19.40
BL294	SC90057	SD-2	5/16	1/4	20.90
BL295	SC90058	SD-3	3/8	5/16	23.30
BL296	SC90059	SD-4	7/16	3/8	20.20
BL297	SC90060	SD-5	1/2	7/16	31.40
BL298	SC90061	SD-6	5/8	9/16	38.90
BL299	SC90062	SD-7	3/4	11/16	53.80
BL300	SC90063	SD-9	1	15/16	92.40

CLARKSON OSBORN

TREE SHAPE - RADIUS END

Model No.	Mfg. No.	No.	Head Dia.™	Flute Length™	Price/Each
BL434	SC90613	SF-1L6	1/4	1/2	30.80
BL435	SC90614	SF-3L6	3/8	3/4	38.90
BL436	SC90615	SF-5L6	1/2	1	57.30

TREE SHAPE - POINTED END

Model No.	Mfg. No.	No.	Head Dia.™	Flute Length™	Price/Each
BL437	SC90616	SG-1L6	1/4	1/2	30.80
BL438	SC90617	SG-3L6	3/8	3/4	41.40
BL439	SC90618	SG-5L6	1/2	1	56.50

FLAME SHAPE

Model No.	Mfg. No.	No.	Head Dia.™	Flute Length™	Price/Each
BL440	SC90619	SH-2L6	5/16	3/4	40.80
BL441	SC90620	SH-5L6	1/2	1 1/4	83.10

14° DEGREE TAPER - RADIUS END

Model No.	Mfg. No.	No.	Head Dia.™	Flute Length™	Price/Each
BL442	SC90621	SL-1L6	1/4	5/8	31.50
BL443	SC90622	SL-3L6	3/8	1 1/16	49.60
BL444	SC90623	SL-4L6	1/2	1 1/8	60.70

SOLID CARBIDE BURRS - 1/4" SHANK

SC90 DOUBLE CUT

- 1/4" shank
- Double cut
- Ideal for extra tough materials
- Excellent control allows for clean finish

OVAL SHAPE



Model No.	Mfg. No.	No.	Head Dia. "	Flute Length"	Price /Each
TBM290	SC90064	SE-11	3/16	5/16	23.70
BL301	SC90065	SE-1	1/4	3/8	23.70
BL302	SC90066	SE-3	3/8	5/8	28.40
BL303	SC90067	SE-5	1/2	7/8	41.60
BL304	SC90068	SE-6	5/8	1	57.80
BL305	SC90069	SE-7	3/4	1	77.50

TREE SHAPE - WITH RADIUS END



Model No.	Mfg. No.	No.	Head Dia. "	Flute Length"	Price /Each
BL306	SC90070	SF-11	1/8	1/2	22.00
BL307	SC90071	SF-1	1/4	5/8	22.00
BL308	SC90072	SF-3	3/8	3/4	27.80
BL309	SC90073	SF-4	7/16	1	38.60
BL310	SC90074	SF-5	1/2	1	41.10
BL311	SC90075	SF-13	1/2	3/4	41.10
BL312	SC90076	SF-6	5/8	1	56.80
BL313	SC90077	SF-7	3/4	1	74.60
BL314	SC90078	SF-14	3/4	1 1/4	93.90
BL315	SC90079	SF-15	3/4	1 1/2	110.00

TREE SHAPE - POINTED END



Model No.	Mfg. No.	No.	Head Dia. "	Flute Length"	Price /Each
BL316	SC90080	SG-1	1/4	5/8	22.00
BL317	SC90081	SG-2	5/16	3/4	26.80
BL318	SC90082	SG-3	3/8	3/4	29.70
BL319	SC90083	SG-5	1/2	1	40.30
BL320	SC90084	SG-13	1/2	3/4	40.30
BL321	SC90085	SG-6	5/8	1	56.10
BL322	SC90086	SG-7	3/4	1	74.60
TBM291	SC90087	SG-15	3/4	1 1/2	110.00

FLAME SHAPE



Model No.	Mfg. No.	No.	Head Dia. "	Flute Length"	Price /Each
BL323	SC90088	SH-1	1/4	5/8	25.90
BL324	SC90089	SH-2	5/16	3/4	29.20
BL325	SC90090	SH-5	1/2	1 1/4	59.50
BL326	SC90091	SH-6	5/8	1 7/16	82.10
BL327	SC90092	SH-7	3/4	1 5/8	104.00

60° CONE SHAPE



Model No.	Mfg. No.	No.	Head Dia. "	Flute Length"	Price /Each
BL328	SC90093	SI-1	1/4	3/16	19.40
BL329	SC90094	SI-3	3/8	5/16	25.30
BL330	SC90095	SI-5	1/2	7/16	30.90
BL331	SC90096	SI-6	5/8	9/16	41.10
BL332	SC90097	SI-7	3/4	11/16	53.90
BL333	SC90098	SI-9	1	15/16	86.50

90° CONE SHAPE



Model No.	Mfg. No.	No.	Head Dia. "	Flute Length"	Price /Each
BL334	SC90099	SK-1	1/4	1/8	19.40
BL335	SC90100	SK-3	3/8	3/16	25.30
BL336	SC90101	SK-5	1/2	1/4	30.90
BL337	SC90102	SK-6	5/8	5/16	41.10
BL338	SC90103	SK-7	3/4	3/8	53.90
BL339	SC90104	SK-9	1	1/2	86.50

SOLID CARBIDE BURRS - 1/4" SHANK

SC90 DOUBLE CUT



TAPER - RADIUS END - 14°

Model No.	Mfg. No.	No.	Head Dia. "	Flute Length"	Price /Each
BL340	SC90105	SL-1	1/4	5/8	22.60
BL341	SC90106	SL-2	5/16	7/8	29.60
TBM292	SC90107	SL-3	3/8	1 1/16	35.50
BL342	SC90108	SL-4	1/2	1 1/8	43.30
BL343	SC90109	SL-5	5/8	1 3/16	77.40
BL344	SC90110	SL-6	5/8	1 5/16	85.30
BL345	SC90111	SL-7	3/4	1 1/2	113.00

CONE SHAPE



Model No.	Mfg. No.	No.	Head Dia. "	Flute Length"	Price /Each
BL346	SC90112	SM-1	1/4	1/2	21.40
BL347	SC90113	SM-2	1/4	3/4	22.60
BL348	SC90114	SM-3	1/4	1	24.10
BL349	SC90115	SM-4	3/8	5/8	35.50
BL350	SC90116	SM-5	1/2	7/8	44.60
BL351	SC90117	SM-6	5/8	1	59.50

INVERTED CONE SHAPE



Model No.	Mfg. No.	No.	Head Dia. "	Flute Length"	Price /Each
BL352	SC90118	SN-1	1/4	5/16	19.40
BL353	SC90119	SN-2	3/8	3/8	25.30
BL354	SC90120	SN-4	1/2	1/2	30.90
BL355	SC90121	SN-6	5/8	3/4	41.10
BL356	SC90122	SN-7	3/4	5/8	53.90

CLARKSON OSBORN

8 PIECE SOLID CARBIDE BURR SET - 1/4" SHANK

Model No.
BL445
Mfg. No.
SC90801
Price/Each
390.00



KIT CONTAINS:

NO.	Head Dia. "	Flute Length"
SA-5	1/2	1
SC-3	3/8	3/4
SC-5	1/2	1
SD-5	1/2	7/16
SE-3	3/8	3/4
SF-5	1/2	1
SG-3	3/8	3/4
SL-4	1/2	1 1/8

PARTS CLEANER

DIP TANKS

- Manually operated covers which stay open for convenient access
- Cover is equipped with a self-closing mechanism and fusible link which melts at 165°F to snap the cover shut in case of fire
- Constructed of 24-gauge coated steel, durable powder coat paint finish for long use
- Available with polyethylene liner for outstanding chemical resistance to harsh, corrosive chemicals

SD562



Model No.	Description	Outside Dim.			Approved Regulation	Wt. lbs/kg	Price /Each
		Dia."	x	H"			
SD561	1-gallon steel dip tank	9 3/8	x	5 1/2	FM,UL	5/2.3	105.00
SD562	2-gallon steel dip tank	9 3/8	x	10	FM,UL	6/2.7	107.00
SD563	3.5-gallon steel dip tank	11 3/8	x	11 1/4	FM,UL	8/3.6	120.00
SD564	5-gallon steel dip tank	13 3/4	x	13	FM,UL	10/4.5	137.00
WN969	5-gallon steel dip tank w/HDPE liner	13 3/4	x	13	FM	12/5.5	349.00
WN970	8-gallon steel dip tank	15 5/8	x	14 1/4	FM,UL	13/5.9	166.00

BENCH CANS

- Spring-loaded, perforated plated steel dasher plate
- Simply press down and agitate, then release to return to drain position
- Effective flame arrester
- Hinged cover minimizes evaporation losses
- Protected rim reduces the possibility of hand injury
- 24-gauge premium coated steel
- Powder coat paint finish adds durability



AB491



Model No.	Description	Dasher Dia."	Outside Dim.			Approved Regulation	Wt. lbs/kg	Price /Each
			Dia."	x	H"			
WN978	1-quart steel bench can	4 1/2	4 7/8	x	5 1/2	FM	2/0.9	61.60
AB491	2-quart steel bench can	7 1/2	9 3/8	x	3 1/4	FM	4/1.8	75.60
AB492	1-gallon steel bench can	7 1/2	9 3/8	x	4 1/2	FM	5/2.3	68.50
WN979	1-gallon steel bench can w/parts basket	7 1/2	9 3/8	x	4 1/2	FM	5/2.3	94.50
AB493	2-gallon steel bench can	9 3/4	11 1/2	x	5 3/8	FM	8/3.6	121.00
AB494	3-gallon steel bench can	12 1/8	13 1/2	x	6	FM	9/4.1	137.00
WN980	Optional 24-gauge parts basket	-	6 7/16	x	7/16	-	1/0.5	23.30

WASH TANKS

- Cover opens wide for access
- Integral parts basket facilitates washing quantities of small parts quickly
- Can and basket are made of sturdy 24-gauge coated steel
- After cleaning, the basket is positioned at the top of the tank to allow solvent to drain
- Cover is equipped with a self-closing mechanism and fusible link which melts at 165°F and snaps the cover shut in case of fire
- Available with polyethylene liner for outstanding chemical resistance to harsh, corrosive chemicals

SM432



Model No.	Description	Outside Dim.			Approved Regulation	Wt. lbs/kg	Price /Each
		Dia."	x	H"			
WN971	1-gallon steel wash tank w/basket	9 3/8	x	10	FM,UL	7/3.2	159.00
WN972	2-gallon steel wash tank w/basket	11 3/8	x	11 1/4	FM,UL	9/4.1	186.00
WN973	3.5-gallon steel wash tank w/basket	13 3/4	x	13	FM,UL	12/5.5	191.00
WN974	3.5-gallon steel wash tank w/HDPE liner and basket	13 3/4	x	13	FM	14/6.4	466.00
SM432	6-gallon steel wash tank w/basket	15 5/8	x	14 1/4	FM,UL	16/7.3	205.00

RINSE TANKS

- Large parts (up to 16" x 35") can be totally immersed
- Heavy-duty, 18-gauge coated steel construction
- Tough powder coat paint finish for superior durability and chemical resistance

FLOOR STANDING RINSE TANKS

- Supported on a sturdy stand, 33" height for convenient access whether standing or seated
- Self-closing cover is foot-treadle operated so it can be opened by a worker with both hands full
- Adjustable-rate pneumatic cylinder prevents cover from slamming shut instantly
- A 3/4" drain plug allows for easy solvent replacement

Clean larger parts with ease!

BENCH TOP RINSE TANKS

- Sit conveniently on work bench or counter for easy access
- Lift-and-latch style cover has fusible link that melts at 165°F and closes the cover in case of fire
- A 3/4" drain plug allows for easy solvent replacement

SEDIMENT SCREENS

- 26-gauge premium coated steel
- Rests at bottom of tank to catch grime as it settles and allows for easy cleaning during solvent change

PARTS BASKETS

- 26-gauge premium coated steel
- Carries numerous smaller parts to be washed in a single action

TANKS

Model No.	Description	Dimensions				Approved Regulation	Wt. lbs/kg	Price /Each
		L"	x	W"	x D"			
FLOOR STANDING & BENCH TOP RINSE TANKS								
SM434	11-gallon steel floor standing rinse tank	24	x	16	x 8 3/4	FM	60/27	647.00
SM431	11-gallon steel bench top rinse tank	24	x	16	x 8 3/4	FM	29/13	476.90
SM433	22-gallon steel floor standing rinse tank	35 1/4	x	16	x 12	FM	78/35	805.00
WN975	22-gallon steel bench top rinse tank	35 1/4	x	16	x 12	FM	48/22	761.00
TWIN CHAMBER RINSE TANKS								
WN976	2 x 4-gallon steel floor standing rinse tank	24	x	16	x 8 3/4	FM	62/28	873.00
WN977	2 x 9-gallon steel floor standing rinse tank	35 1/4	x	16	x 12	FM	80/36	1008.00

SEDIMENT SCREENS & PART BASKETS

Model No.	Description	Dimensions				Wt. lbs/kg	Price /Each
		L"	x	W"	x D"		
SM437	Sediment screen for tank models SM434 and SM431	23	x	13 3/4	x 3/4	3/1.4	51.40
SM436	Sediment screen for rinse tank models SM433 and WN975	35	x	13 3/4	x 3/4	4/1.8	73.60
SM430	Parts basket for rinse tank models SM434 and SM431	16	x	13	x 4	4/1.8	115.00
SM428	Parts basket for rinse tank models SM433 and WN975	28	x	13	x 4	6/2.7	154.00



SM433



STEEL FUNNELS WITH EXTENSION

- Galvanized steel funnel comes with a flexible extension
- 1/2" diameter hose for 1-pint model, 3/4" diameter for larger sizes

Model No.	Cap.	Top Dia."	Hose Spout Length"	Spout Dia."	Price /Each
NB027	1 pint	4 3/4	9	3/8	41.90
NB028	1 quart	5 7/8	8	1/2	30.50
NB025	1/2 gal.	7 5/8	8 1/2	1/2	36.10
NB026	1 gal.	8 7/8	10	1/2	40.80



STEEL FUNNELS WITH EXTENSION

- 8 3/4" diameter galvanized steel funnel with brass screen strainer
- 16" long flexible extension
- 15/16" spout diameter
- Capacity: 2 gallons
- Suitable for use with tractors

Model No. NB001
Price/Each \$52.50



STRAINER FUNNELS

- Tin strainer funnels have a built-in screen that prevents the flow of harmful particles into the liquid

Model No.	Cap.	Top Dia."	Body Ht."	Spout Ht."	Spout Dia."	Price /Each
NB069	1 pint	4 3/4	3 7/16	2 1/16	3/8	8.69
NB070	1 quart	5 3/4	4 5/16	2 3/8	1/2	9.21
NB067	1/2 gal.	7 1/2	5 5/8	2 11/16	5/8	10.60
NB068	1 gal.	8 3/4	6 1/2	3 1/2	3/4	13.10



UTILITY FUNNELS

- Lightweight tin and galvanized steel funnels available in capacities from 1 pint to 1 gallon

Cap.	Top Dia."	Body Ht."	Spout Ht."	Spout Dia."	Tin Model No.	Price /Each	Galv. Model No.	Price /Each
1 pint	4 3/4	3 7/16	2 1/16	3/8	NB077	5.59	NB031	11.50
1 quart	5 3/4	4 5/16	2 3/8	1/2	NB078	6.00	NB032	13.10
1/2 gal.	7 1/2	5 5/8	2 11/16	5/8	NB075	7.04	NB029	18.00
1 gal.	8 3/4	6 1/2	3 1/2	3/4	NB076	9.42	NB030	22.70



STEEL FUNNELS

- Suitable for use with tractors
- Galvanized steel funnel has 8 3/4" diameter and comes with a brass screen strainer
- Body height: 7 1/2"
- Spout height: 4 13/16"
- Spout diameter: 15/16"
- Capacity: 2 gallons

Model No. NA999
Price/Each \$24.70



LIQUID MEASURES

A. FLEXIBLE SPOUT

- Spill proof top
- Flexible spout makes it easy to reach difficult areas and hard to reach pouring angles
- Flexible spout length: 8"
- Spout diameter: 1/2"
- Available in tin, galvanized steel or stainless steel



B. OPEN TOP

- Available in tin, galvanized steel or stainless steel



NON-TILT STEEL FUNNELS

- Suitable for use with tractors
- Non-tilt feature allows funnel to remain upright when in use
- Galvanized steel funnel has 8 3/4" diameter, comes with brass screen strainer
- 15/16" spout diameter
- Capacity: 2 gallons

Model No. NB004
Price/Each \$30.50



Cap.	Tin Model No.	Dia." x H"	Price /Each	Galvanized Model No.	Dia." x H"	Price /Each	Stainless Model No.	Dia." x H"	Price /Each
A. FLEXIBLE SPOUT									
1 quart	NB082	4 1/4 x 4 3/4	49.50	NB035	4 x 5 7/16	50.30	NB056	4 x 5 7/16	63.00
1/2 gallon	NB079	4 1/4 x 8 7/8	40.50	NB033	5 x 7 1/4	54.80	NB052	4 x 7 1/4	76.10
1 gallon	NB081	6 x 9 3/4	44.00	NB034	6 x 9 3/4	60.00	NB054	6 x 9 3/4	86.90
B. OPEN TOP									
1 quart	NB087	4 1/4 x 4 3/4	31.50	NB038	4 x 5 7/16	43.90	NB061	4 x 5 7/16	57.10
1/2 gallon	NB083	4 1/4 x 8 7/8	29.60	NB036	5 x 7 1/4	40.40	NB057	4 x 7 1/4	70.60
1 gallon	NB085	6 x 9 3/4	38.60	NB037	6 x 9 3/4	55.60	NB059	6 x 9 3/4	77.20

RECIRCULATING PARTS WASHERS

- Safety lever has fusible link which shuts cover in case of fire
- Thermally protected 110 V motor and on/off switch
- Durable pump included
- 3-way filtration traps grime
- Flush hose delivers flow of solvent to rinse parts clean, quickly and easily



BV742



BV743



BV744



5 GALLONS

Capacity: 3.5 gallons
Motor: 0.25 A
Voltage: 110 V, 1 phase, 60 Hz
Dimensions: 18 1/4" x 13 1/2" x 9"
Height of stand: N/A
Weight: 15 lbs.
Model No. BV742*
Price/Each \$90.20

20 GALLONS

Capacity: 12 gallons
Motor: 0.25 A
Voltage: 110 V, 1 phase, 60 Hz
Dimensions: 30 1/2" x 21 1/4" x 10"
Height of stand: 24 1/2"
Weight: 55 lbs.
Model No. BV743*
Price/Each \$195.00

40 GALLONS

Capacity: 30 gallons
Motor: 0.25 A
Voltage: 110 V, 1 phase, 60 Hz
Dimensions: 44 1/2" x 21 1/4" x 10 1/2"
Height of stand: 24 1/2"
Weight: 92 lbs.
Model No. BV744*
Price/Each \$269.00

Call our order desk for a quote when funnels & measures are to be used in food industry.

PARTS CLEANING BRUSHES

Recommended for cleaning motors, machinery and metal parts.



BZ987



TEX274



Model No.	Brush Dia."	Overall Length"	Trim Length"	Qty /Pkg.	Price /Each
BZ987	1 1/8	11	2 3/4	12	5.17
TEX274	1 7/8	37 3/8	3 1/2	1	21.00

Brush Only: 10"

*A material safety data sheet is required for purchase

PARTS CLEANER

POLYETHYLENE FILTER FUNNELS

- Made of chemical resistant polyethylene
- Screen filter included



NC991

Model No.	Dia."	Price/Each
YC564	5	9.90
NC991	9	15.90

CLEANFUNNEL™ SYSTEM

- Prevents dirt, dust and other contaminants from collecting on the inside funnel wall and eliminates the need for cleaning before use



AA763

Model No.	Colour	Size	Length"	Spout"	Price /Each
AA763	Orange	1 pt.	13.5	0.5	6.76
AA765	Dark Blue	1.25 qt.	10.5	0.75	13.10
AA766	Dark Green	1.25 qt.	8.5	1	13.10
AA767	Black	1.3 qt.	10.5	1.5	13.10
AA768	Bright Red	1.5 qt	17 - flexible	0.5	13.10
AA769	Yellow	1.5 qt.	14.25 - flexible	0.75	13.10
AA770	Green	1.5 qt.	12.25 - flexible	1	13.10
AA771	Red	1.6 qt.	14 - flexible	1.5	13.10

FUNNELS

- Translucent high density polyethylene construction
- Wire mesh screen keeps contaminants out
- Comes complete with a polyethylene flexible spout for difficult to reach areas
- Curved funnel ends make the funnel splash and spill proof



TYB517

aurora tools®

Model No.	Diameter"	Capacity	Price /Each
TYB517	8	1.7 litres	9.90
TYB518	9 1/2	3 litres	13.40

DIECAST ALUMINUM SCOOPS

- Bowl and handle cast in one piece for extra heavy-duty use
- Ideal for powders and granulated products



NG648

Model No.	Capacity	Bowl Length"	O.A. Length"	Price /Each
NG648	3/4 quart	7 3/4	11 1/4	17.80
NG649	1 quart	9	13	24.40
NG650	1 1/2 quart	10 1/2	15	26.70

LIQUID MEASURES

- Translucent high density polyethylene construction
- Comes complete with a polyethylene flexible spout for difficult to reach areas
- Cap on flexible spout and polypropylene lid renders measure spill proof
- Spout length: 7 1/2"
- Spout diameter: 3/4"



TYB514

aurora tools®

Model No.	Capacity	Price /Each
TYB513	1 quart	7.95
TYB514	2 quart	9.70
TYB515	3 quart	13.25
TYB516	5 quart	17.55

SMARTWASHER®

SMARTWASHER uses the process of **bioremediation** - the accelerated break down of organic compounds such as grease, grime, varnish, oil, carbon and other heavy industrial soils through the use of nonpathogenic microbes. The microbes, suspended in a fluid that re-circulates through the unit, literally **eat their way through soils**, converting them into harmless water and carbon dioxide (CO₂). The solution remains clean and usable, unlike traditional solvent-based systems where the solution becomes dirty and less effective over time. Disposal becomes a non-issue, as hazardous waste streams are eliminated.

JUST SAY NO!

- NO VOC Concerns
- No Toxic Solvents
- No Flash Point Fluid
- No Service Contracts
- No Hazardous Waste Hauling
- No Health and Safety Hazards

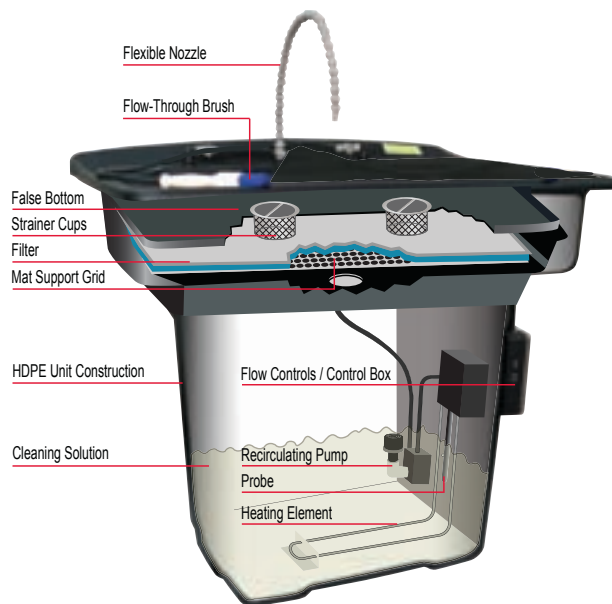



SMARTWASHER® SYSTEMS

The SMARTWASHER System consists of a sturdy, impact resistant, self-contained washing unit with a flexible nozzle and brush that directs warmed cleaning fluid for parts washing. The fluid works in conjunction with a special microbe impregnated filter to effectively clean the dirtiest parts. Each unit requires 25 gallons of SMARTWASHER fluid and one filter for start-up.

SMARTWASHER UNITS FEATURE:

- Flexible nozzle and brush
- Recirculating pump
- Low fluid indicator light/low fluid automatic shut-off
- Impact resistant construction
- Thermostat
- Energy efficient heater

SMARTWASHER® 41

- Removable sink for easy cleaning
- Sink dimensions:
20 cm H x 104 cm W x 61 cm D

Model No. AF127
Mfg. No. 14144
Price/Each \$3859.00



SMARTWASHER® 28

- Removable sink for easy cleaning
- Sink dimensions:
20 cm H x 71 cm W x 43 cm D

Model No. NH774
Mfg. No. 14145
Price/Each \$3486.00



SMARTWASHER® MOBILE UNIT

- Built-in dolly allows for easy mobility
- Sink dimensions:
20 cm H x 69 cm W x 58 cm D

Model No. AF128
Mfg. No. 14161
Price/Each \$3236.00



SMARTWASHER® CLEANING SOLUTIONS

Aqueous, pH neutral, non-corrosive, non-flammable, biodegradable and contains no VOCs. Solutions work in conjunction with filters when warmed to 105°F by the units. All cleaning solutions are certified as Clean Air Solvents by the South Coast Air Quality Management District (SCAQMD).

- **Industrial Grade Cleaning Solutions:** Removes the toughest industrial soils with minimal odour; US EPA Design for Environment (DfE recognized)
- **Automotive & Ink Grade Cleaning Solution:** Removes printers ink and automotive carbon and varnishes
- **Specialty Metals Cleaning Solution:** Maximum strength, low odour formula removes soils from both ferrous and non-ferrous metals; perfect for use on all aircraft metals.



Model No.	Mfg. No.	Description	Container Size	Units /Case	NSF	Price /Each
AF129	14148	Industrial Grade Cleaning Solution	18 L Jug	1	A1	212.00
AF130	14156	Automotive & Ink Grade Cleaning Solution	18 L Jug	1	A1	222.00
AF131	14158	Specialty Metals Cleaning Solution	18 L Jug	1	A1	237.00

SMARTWASHER® FILTERS

Removes dirt and residue particles down to 50 microns. Filters must be used for proper cleaning and operation of SMARTWASHER System.

MULTI-LAYER FILTER

- Three filters in one for heavy use applications
- Simply peel back and remove each layer as it becomes clogged to reveal fresh layer
- Extends working life of filter



Model No.	Mfg. No.	Description	Container Size	Units /Case	Price /Each
NH776	14147	Premium Filters	1 Case	6	37.20

Types of Soil	AF129 Industrial Grade	AF130 Automotive & Ink Grade	AF131 Specialty Metals
Motor Oil	Excellent	Excellent	Excellent
Bearing Grease	Excellent	Fair	Excellent
Automotive Grease	Excellent	Good	Excellent
Impacted Grease	Excellent	Fair	Excellent
Asphalt	Good	Fair	Good
Creosote	Excellent	Fair	Excellent
Resin Products	Excellent	Good	Excellent
Hydraulic/Transmission Fluid	Excellent	Excellent	Excellent
Fifth Wheel Grease	Excellent	Fair	Excellent
Crude Oil	Excellent	Excellent	Excellent
Solder & Flux	Excellent	Excellent	Excellent
Automotive Varnish	Good	Excellent	Good
Burned-On Carbon	Excellent	Excellent	Good
Cutting Oils	Good	Excellent	Good
Ink/Toner	Good	Excellent	Good
Animal Fat	Excellent	Fair	Excellent



MINI PISTOL GREASE GUNS

DELUXE

- Single-hand-operated pistol grip
- Die cast grease gun head with dual discharge ports for use with steel extension as well as flexible hose
- Develops 3500 PSI
- Capacity: 3 oz grease cartridge or bulk fill
- Textured zinc plated finish for non-slip grip
- Includes: 4" steel extension and professional 4-jaw coupler with ball check

Model No. AC477
Price/Each \$17.25

aurora tools®



AC477

PISTOL GREASE GUNS

HEAVY-DUTY

- Designed for use in general confined spaces or where access to grease nipples is restricted
- Heavy-duty die cast grease gun head
- Develops 5000 PSI
- Capacity: 14 oz (400 g) grease cartridge or suction fill
- AC475 comes complete with 4" steel extension and 4-jaw coupler with ball check
- AC476 comes complete with 18" flexible hose and 4-jaw coupler with ball check

Model No. AC475
Price/Each \$27.95

Model No. AC476
Price/Each \$35.65

aurora tools®



AC475

MINI GREASE GUNS

- Designed for use in general confined spaces, or where access to grease nipples is restricted
- Single-hand-operated push type grip
- Develops 1400 PSI
- Capacity: 3 oz. (85 g)

Model No. AD084
Price/Each \$16.25

aurora tools®



AD084

AIR-OPERATED GREASE GUNS

- Ideal for use in factory maintenance
- Single shot of grease discharge with every press of the trigger
- Air operating range: 40 - 120 PSI
- Capacity: 14 oz. (400 g) grease cartridge or bulk fill
- Comes with 6" steel extension and professional 4-jaw coupler with ball check

Model No. AC478
Price/Each \$68.35

aurora tools®



AC478

LEVER GREASE GUNS

STANDARD-DUTY

- Designed for use in general lubrication and daily maintenance work
- Capacity: 14 oz (400 g) grease cartridge or suction fill
- Complete with 6" steel extension and 4-jaw coupler with ball check
- Develops 6000 PSI

Model No. AC472
Price/Each \$20.50

aurora tools®



AC472

HEAVY-DUTY

- Designed for punishing day-in and day-out heavy industrial application
- Built-in variable stroke feature for greasing fittings with limited access
- Die cast grease gun head fitted with bulk loader and air bleeder
- Extra heavy-duty zinc plated lever handle with ergonomic rubber grip
- Develops 10 000 PSI
- Capacity: 14 oz. (400 g) grease cartridge, filler pump or suction fill
- Includes: 6" steel extension and 4-jaw coupler with ball check

Model No. AC473
Price/Each \$29.50

aurora tools®



AC473

SUCTION GUNS

- A rugged transfer gun designed for use with gear oils to get them both into and out of gear boxes, transfer cases and differentials
- Capacity: 16 oz
- Complete with 12" flexible vinyl hose

Model No. AC494
Price/Each \$17.35

aurora tools®



AC494

FLEXIBLE GREASE HOSES

- Standard grease hose is the most popular version of flexible grease hoses
- AC481 hose fitted with heavy-duty spring guard adds safety and convenience in fitment, prevents those from bending
- Threads: 1/8" NPT
- Working Pressure 3500 PSI
- For hand-operated grease guns only

aurora tools®

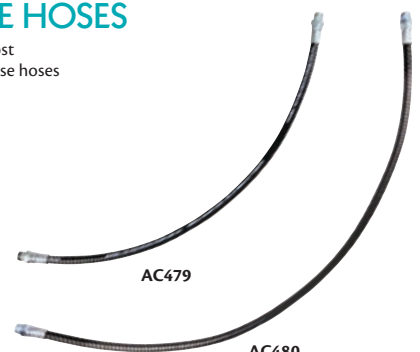

AC479

AC480

Model No.	Length" (End to End)	Price /Each
AC479	12	6.00
AC480	18	7.75
AC481	18	8.45

PISTOL GRIP GREASE GUNS

PROFESSIONAL-DUTY

Develops 5500 PSI. Three-way loading: cartridge, suction or loader pump. Features automatic variable stroke/pressure, air vent, vinyl grip and loader fitting. Delivery: 1 oz. per 33 strokes.

Model No. AA690
Includes: rigid extension and coupler
Price/Each \$72.71

Model No. AA691
Includes: 18" flexible hose and coupler
Price/Each \$75.88



PNEUMATIC GREASE GUNS

Three way loading: cartridge, suction or loader pump. Features air vent, loader fitting, rigid extension and coupler.

Model No. AB821
Price/Each \$104.54



LEVER GREASE GUNS

PROFESSIONAL-DUTY

Develops 10 000 PSI. Three-way loading: 14 oz. cartridge, suction or loader pump. Features automatic variable stroke/pressure, air vent, vinyl grip, loader fitting.

Delivery: 1 oz. per 21 strokes.

Model No. AA643
Includes: rigid extension and coupler
Price/Each \$56.03

Model No. AB827
Includes: 18" hose and coupler
Price/Each \$67.14

Model No. AB825
Includes: 24 oz. cylinder, rigid extension and coupler
Price/Each \$65.83

AA643



SUCTION GUNS

16 oz. capacity. Includes flexible vinyl hose. Suitable for all purpose draining of non-corrosive lubricants.

Model No. AB833
Price/Each \$23.56



HEAVY-DUTY/HIGH PRESSURE

Develops 10 000 PSI. Three-way loading: cartridge, suction or loader pump. Features heavy-duty lever with adjustable linkage for high pressure or high volume operation and loader fitting. Gun outlet 1/8" NPTF.

Delivery: 1 oz. per 16 strokes in high volume mode.

Delivery: 1 oz. per 25 strokes in high pressure mode.

Model No. AB817
16-oz. gun only
Price/Each \$197.98

Model No. AA692
16-oz. gun with rigid extension and coupler
Price/Each \$224.05

Model No. AB816
24-oz. gun with rigid extension and coupler
Price/Each \$232.59

AA692



12 V CORDLESS GREASE GUNS

Lightweight, powerful, professional quality. The most innovative grease gun ever designed, giving you faster more efficient lubrication:

- High-Pressure Delivery: up to 6500 PSI
- High Flow Rate: 5.25 oz. per minute @ 1000 PSI
- 3-Way Loading: 14-oz. cartridge, 16-oz. bulk or suction loaded
- Lightweight: 6.8 lbs.
- Comes with two batteries

Model No. AB812
Price/Each \$454.00



GREASE GUN EXTENSION HOSES

WARNING: For use with hand operated grease guns only.

- Economical and durable hose
- 12 000 PSI burst pressure
- 1/8" NPTF(M) ends



AA693

Model No.	Length"	Working Pressure	Hose Type	Price /Each
AA693	12	4800 PSI	Single Wire Braid	17.50
AA694	18	4800 PSI	Single Wire Braid	20.00

LUBRICATING EQUIPMENT

PROFESSIONAL COUPLERS

- Hardened spring steel jaws and hardened body withstands high pressure without deformation
- Hexagonal nut allows easy tightening
- Threads: 1/8" NPT
- 4-jaw construction, 6000 PSI
- For hand-operated grease gun only

Model No. AC482
Price/Each \$4.95

aurora tools



HEAVY-DUTY COUPLERS

- Hardened spring steel jaws & hardened body with double wall thickness withstands very high pressure without deformation
- Hexagonal nut allows easy tightening
- Threads: 1/8" NPT
- 4-jaw construction, 10 000 PSI
- For hand and air operated equipment

Model No. AC483
Price/Each \$8.95

aurora tools



HYDRAULIC COUPLERS - 360° SWIVEL

- Excellent coupler for effective lubrication of difficult and hard to reach grease fittings
- Swivels in full 360° circle and locks conveniently at any 45° position
- Spring loaded ball-check valve helps retain pressure
- Threads: 1/8" NPT
- 3-jaw construction, 7000 PSI

Model No. AC484
Price/Each \$42.50

aurora tools



HYDRAULIC COUPLERS - RIGHT ANGLED

- Fits all standard grease gun
- Designed for right angled discharge of grease, very useful for greasing fittings with limited access or in low heights
- Threads: 1/8" NPT
- 10 000 PSI

Model No. AC485
Price/Each \$10.95

aurora tools



SEAL-OFF DISPENSERS

- Used with grease gun extension or hose for lubricating grease plugs
- Threads: 1/8" NPT

Model No. AC491
Price/Each \$13.30

aurora tools



STEEL BEARING PACKERS

- For use with grease guns
- The design incorporates a grease nipple at one end which easily adapts to the grease gun coupler
- Grease bearings in cars boats, RV, etc. with a minimum inner diameter of 1/2" to a maximum outer dia of 5" and height from 1/4" to 2"

Model No. AC493
Price/Each \$31.15

aurora tools



GREASE GUN HOLDERS

- Simple snap action clamp for safe storage of grease guns and suction guns

Model No. AC486
Price/Each \$7.20

aurora tools



GREASE INJECTOR NEEDLES

- Lubricates in very tight spaces such as universal joints and sealed bearings
- Equipped with standard grease fitting without ball check and protective plastic holder
- 18-gauge needle thickness
- 1 1/2" long

Model No. AC487
Price/Each \$8.50

aurora tools



NEEDLE NOSE DISPENSERS

- Used for dispensing a fine line of grease
- Can be attached directly to steel extensions or flexible hoses
- Threads: 1/8" NPT
- AC490 has a narrow needle with a dia of 3.96 mm
- AC489 has a 5.56 mm needle dia

Model No.	Needle Length mm	Price /Each
AC489	15	7.35
AC490	38	11.75

aurora tools



NEEDLE NOSE ADAPTORS

- Used for dispensing a fine line of grease through the needle nose
- Tip diameter: 0.046" (1.168 mm)
- Needle length: 4"
- Quick connect action

Model No. AC488
Price/Each \$23.60

aurora tools



EZEE-LUBE KITS

- The Ezee-Lube kit comprises of a range of quick-connect fittings designed to meet any and every greasing application lube accessories

Model No. AC492
Price/Each \$99.95

aurora tools



aurora tools®

OIL CANS

- Oil can body is seamless drawn from heavy-gauge tin coated sheet
- Premium powder coated finish

Model No.	Capacity oz.	Spout Length"	Spout Type	Pump	Price /Each
LEVER TYPE					
AC514	6	6	Flexible	Steel	8.30
AC515	10	6	Flexible	Steel	9.10
AC589	13	7	Flexible	Steel	10.70
AC516	16	7	Flexible	Steel	10.30
AC592	16	9	Flexible	Steel	15.45
AC593	16	9	Rigid	Steel	15.00
AC590	23	8	Flexible	Steel	11.95
AC594	33	9	Flexible	Steel	20.75
AC595	33	9	Rigid	Steel	19.60
PISTOL TYPE					
AC588	4	5	Flexible	Steel	6.50
AC513	6	5	Flexible	Steel	9.95
AC597	6	6	Flexible	Steel	12.60
AC596	6	6	Rigid	Steel	9.85
AC599	16	6	Flexible	Steel	17.95
AC598	16	6	Rigid	Steel	18.90
AC600	33	6	Rigid	Steel	26.30



HYDRAULIC GREASE COUPLERS

Provides quick, positive and leakproof connection with hydraulic fittings.

AA862



Model No.	Type	Thread	Max. Pressure PSI	Price /Each
QG997	Standard	1/8" NPTF(F)	10 000	16.10
AB742*	Standard	1/8" NPTF(F)	10 000	22.86
QF621	Narrow	1/8" NPTF(F)	10 000	11.93
AA862*	Narrow	1/8" NPTF(F)	10 000	17.65

*Equipped with built-in check valve

MANUAL LUBRICATION PUMPS

VOLUME DELIVERY BUCKET PUMPS

For all oils and pressure gun lubricants. Delivery 1/3 oz. per stroke. Will develop up to 500 PSI. Equipped with 25-lb capacity (5 gallons) container. Adjustable leverage adapts pump to lubricant and operating conditions. Pump outlet: 3/8" NPTF(F).

Model No. AA699
Price/Each \$706.24



MULTI-PRESSURE BUCKET PUMPS

Variable pressure 2500 to 5000 PSI for 35-lb capacity (5 gallons). Adjustable leverage (three positions) adapts pump to all lubricant and operating conditions. Approximate delivery 1/3 oz. per stroke. Suitable for oil or grease. Hose length: 5'.

Coupler type: hydraulic (narrow). Includes hose assembly (Mfg. No. 322434)

Model No. AA698
Price/Each \$599.00



PORTA-CARTS

- Used with AA699 and AA698 series pumps
- Speeds lubrication service where machines are widely separated
- Reduces operator fatigue
- Overall width: 18"

Model No. AA702
Price/Each \$561.57

VOLUME DELIVERY LOADER PUMPS

- For grease guns with Alemite loader fitting
- Delivery: 1 lbs. per 6 strokes
- Includes loader extension and loader fitting
- For 35-lb pail
- Equipped with cover and flexible follower

Model No. AB814
Price/Each \$505.51



DUAL LEVERAGE DISPENSERS

- For fluid gear lubricants
- Attach directly onto original containers
- Delivery: 1 pint per 6 strokes
- Pump outlet: 1/2" NPTF(F).
- For 5-gallon pail
- Includes: 5 1/2' hose with curved nozzle and pail cover

Model No. AB815
Price/Each \$457.44



LUBRICATING EQUIPMENT

GREASE FILLER PUMPS

- An ideal grease filling solution to easily load bulk or combination grease guns from bulk grease pails
- Full economy in buying bulk grease
- Pail capacity: 5 gallons
- Rubber lining follower plate for use with most bucket types

Model No. AD383
Price/Each \$81.95

aurora tools



BUCKET GREASERS

- High volume, high pressure grease pump
- Uses low cost bulk grease
- Delivers 3 g/stroke or 1 oz. in less than 10 strokes at pressures up to 2000 PSI
- Comes complete with 22-lb built-in steel grease bucket

Model No. AC495
Price/Each \$252.00

aurora tools



AIR-OPERATED GREASE PUMPS

- Ideal for applications having continuous need for high pressure grease
- 50:1 ratio pump
- Recommended air pressure between 60 and 125 PSI
- Air inlet: 1/4" NPT (female)
- Grease outlet: 1/4" NPT (female)
- Fits 5-gallon and 16-gallon pails
- Comes complete with drum cover, rubber-lined follower plate, 7' of high pressure grease hose, Z swivel and grease control valve

Model No. AC496 For 25-50-lb. pails
Price/Each \$910.00

Model No. AC497 For 120-lb. pail
Price/Each \$1075.00

aurora tools



SWIVELS

- Installed between the delivery hose and grease control valve, swivels permit easy handling of control valves and prevent damage to hose caused by twisting
- 6000 PSI

aurora tools

Model No.	Thread Specifications	Price /Each
AC499	1/4" NPT (F) - 1/8" NPT (M)	82.95
AC500	1/4" NPT (F) - 1/4" NPT (M)	82.95



GREASE CONTROL VALVES

- Premium quality
- For use with power-operated equipment
- Provides continuous grease flow with trigger fully depressed
- Inlet thread specification: 1/4" NPT (female)
- Outlet thread specification: 1/8" NPT (female)
- 7500 PSI
- Comes complete with 6" steel extension and heavy-duty coupler

Model No. AC498
Price/Each \$130.00

aurora tools



EASY-OUT TOOLS

- Handy, dual-purpose tool for removing worn and broken grease fittings, as well as retapping holes for installing new grease fittings

aurora tools

Model No.	Tap Rethreads	Price /Each
AC511	1/4"-28	17.20
AC512	1/8"-27	14.80



GREASE FITTINGS

- Manufactured to the most stringent quality standards
- QS 9000 approved
- 10 fittings per package



SAE

Priced per Package

Model No.	Description	Price /Each
1/4" - 28 SAE-LT PIPE THREADS		
AC501	Short - Straight	5.20
AC502	Short - 45°	7.25
AC503	Short - 90°	9.25
1/8" - 27 PIPE THREADS		
AC504	Short - Straight	5.90
AC505	Short - 45°	8.80
AC506	Short - 90°	8.80
DRIVE FITTING		
AC507	For 3/16" Drill	5.65

METRIC

Priced per Package

Model No.	Description	Price /Each
M6 X 1 PIPE THREADS		
AD202	Straight	4.67
AD203	90°	8.24
M8 X 1 PIPE THREADS		
AD204	Straight	5.46
AD205	90°	15.12
M10 X 1 PIPE THREADS		
AD206	Straight	5.46
AD207	90°	15.12

SETS

Model No.	Description	Contains	Price /Each
AC509	80 Pcs of SAE Grease Fittings	15 Pcs of 1/4" 28 SAE LT Straight 10 Pcs of 1/4" 28 SAE LT 45° Angle 10 Pcs of 1/4" 28 SAE LT 90° Angle 25 Pcs of 1/8" 27 NPT Straight 10 Pcs of 1/8" 27 NPT 45° Angle 10 Pcs of 1/8" 27 NPT 90° Angle	43.95
AC510	80 Pcs of Metric Grease Fittings	20 Pcs of M6 x 1 Straight 10 Pcs of M6 x 1 90° Angle 15 Pcs of M8 x 1 Straight 10 Pcs of M8 x 1 90° Angle 15 Pcs of M10 x 1 Straight 10 Pcs of M10 x 1 90° Angle	43.95



aurora tools

VEHICLE FITTING ASSORTMENTS

- Box contains six types of popular fittings
- An identifying chart is included in the cover



AA720

ASSORTMENT INCLUDES:

Model No.	Type	Thread	Quantity
AA677	Str.	1/8" P.T.F.	24
AA686	45°	1/8" P.T.F.	12
AA680	90°	1/8" P.T.F.	12
AA684	Str.	1/4"-28 Taper	24
AA683	45°	1/4"-28 Taper	12
AA689	90°	1/4"-28 Taper	12

Model No. AA720 Price/Each \$144.50

METRIC FITTING ASSORTMENTS

- Box contains six types of popular metric fittings
- An identifying chart is included in the cover
- Thread conforms to German Standard DIN 71412



AB820

ASSORTMENT INCLUDES:

Model No.	Type	Thread	Quantity
AB845	Str.	6	10
AB839	45°	6	6
AB840	90°	6	6
AB844	Str.	8	6
AB841	90°	8	6
AB842	Str.	10	10

Model No. AB820 Price/Each \$114.14

POCKET PACK FITTING ASSORTMENTS

- Box contains six types of popular fittings
- An identifying chart is included in the cover



AB826

ASSORTMENT INCLUDES:

Model No.	Type	Thread	Quantity
AA677	Str.	1/8" PTF	12
AA686	45°	1/8" PTF	6
AA680	90°	1/8" PTF	6
AA684	Str.	1/4"-28 Taper	12
AA683	45°	1/4"-28 Taper	6
AA689	90°	1/4"-28 Taper	6

Model No. AB826 Price/Each \$60.80

LUBRICATION BULK FITTINGS 1/4" - 28 TAPER THREADS

- Used on most cars and trucks and on many industrial machines
- Features dirt excluding ball check
- Maximum pressure: 10 000 PSI

It is recommended that SAE-LT taper threads be assembled into 1/4" - 28 UNF, Class 3B, straight threaded holes having a modified maximum minor diameter of 0.2151" to insure 75% minimum thread height.

SAE-LT - conforms to Society of Automotive Engineers Lubrication thread specification.



1/8" PIPE THREADS

- Used on many industrial machines and heavy equipment
- Features dirt excluding ball check
- Maximum pressure: 10 000 PSI

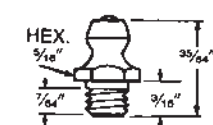

AA684

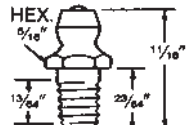

AA685

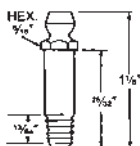

AA497

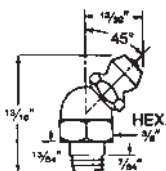

AA683

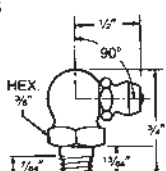

AA689

Model No.	Mfg. No.	Type	Overall Length"	Shank Length"	Hex Size"	Price /Each
AA684	1641-B	Str.	35/64	3/16	5/16	0.73
AA685	1652-B	Str.	11/16	23/64	5/16	1.53
AA497	1698-B	Str.	1 1/8	25/32	5/16	2.90
AA683	1637-B1	45°	13/16	13/64	3/8	1.59
AA689	1911-B1	90°	3/4	13/64	3/8	1.46

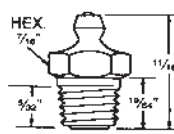

AA677

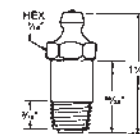

AA676

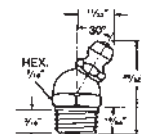

AA678

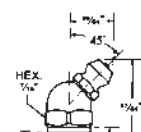

AA686

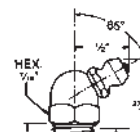

AA679

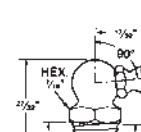

AA680

Model No.	Mfg. No.	Type	Overall Length"	Shank Length"	Hex Size"	Price /Each
AA677	1610-BL	Str.	11/16	19/64	7/16	0.86
AA676	1607-B	Str.	1 1/4	25/32	7/16	2.19
AA678	1611-B	30°	29/32	19/64	7/16	1.70
AA686	1688-B	45°	57/64	19/64	7/16	1.63
AA679	1612-B	65°	27/32	19/64	7/16	1.65
AA680	1613-B	90°	27/32	19/64	7/16	1.53

DRIVE FITTINGS

- Used extensively to avoid tapping costs in a wide variety of applications
- Alemite serrated shank grips securely and simplifies the replacement of damaged fittings in old or oversized holes
- Recommended only for low and medium pressures

IMPORTANT

Actual drill sizes cannot be shown because drilling varies with hardness of metal. Drill sizes indicated on drawings are merely a guide. Exact drill size can only be determined by sample drilling of the actual metal. When drilled to proper tolerance, the serrated edge of the fitting will provide a secure, lasting grip.

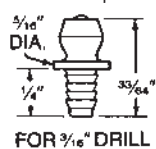

AA687

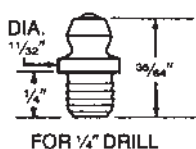

AA688

Model No.	Mfg. No.	Type	Overall Length"	Shank Length"	Drill Dia."	Price /Each
AA687	1728-B	Str.	33/64	1/4	3/16	1.18
AA688	1743-B	Str.	35/64	1/4	1/4	1.35

1/4" PIPE THREADS

- Widely used for larger bearings on farm machinery and heavy industrial equipment
- Recommended for heavy lubricants in cold weather
- Features dirt excluding ball check
- Maximum pressure: 10 000 PSI

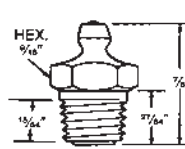

AA681

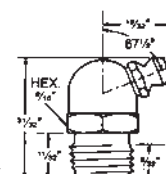

AA682

Model No.	Mfg. No.	Type	Overall Length"	Shank Length"	Hex Size"	Price /Each
AA681	1627-B	Str.	7/8	27/64	9/16	2.62
AA682	1629-B	67 1/2°	31/32	11/32	9/16	2.77



SAFETY TIP

To assure material compatibility, test product on a small inconspicuous area or similar expendable component prior to use. Do not use on energized electrical equipment or equipment in operation and allow surface to dry before restart.

INSTANT SUPER DEGREASER

- Heavy-duty performance
- Power blast spray
- Non-flammable
- Non-chlorinated
- Safe on most metals (as per MIL-T-81533A)
- NSF registered category code C1
- Accepted for use in Canadian food processing facilities



Model No.	Mfg. No.	Size	Price /Each
AD727	C00720	20 oz.	49.70

EVR® CLEAN AIR SOLVENT DEGREASER

- High solvent strength, fast evaporating, low VOC content
- Not a Hazard Air Pollutant (HAP)
- Instant cleaning action
- Ideal for cleaning metals
- No residue or ozone depleting compounds
- Inverta spray valve allows can to be sprayed at almost any angle
- NSF registered category code C1



Model No.	Mfg. No.	Size	Price /Each
AD060	C05220	14 oz.	17.30
AD061	C05201	1 gal.	70.70
AD062	C05205	5 gal.	367.00
AD063	C05255	55 gal.	2667.00

F-104° SOLVENT DEGREASER

- 104°F (40°C) flash point
- Rapid evaporation
- Low odour
- Non-conductive
- No rinsing and no residue
- Heavy-duty cleaner/degreaser
- Safe to use on most surfaces - may be harmful to some plastics



Model No.	Mfg. No.	Size	Price /Each
AA919	C04920	15 oz.	19.30
AB589	C04905	5 gal.	374.00
AB591	C04955	55 gal.	3226.00

T-91 NON-SOLVENT DEGREASER

- Zero VOC's, biodegradable
- Non-flammable, non-toxic, low odour
- Safe on metals
- Non-dilutable - Must be used straight
- Moderate foam for effective mechanical cleaning
- Ideal for traditional solvent cleaning, basin style part washers and dip tanks
- NSF registered category code A1
- Accepted for use in Canadian food processing facilities



Model No.	Mfg. No.	Size	Price /Each
AD295	C06328	28 oz.	19.50
AD183	C06301	1 gal.	65.10
AD184	C06305	5 gal.	307.00
AD185	C06355	55 gal.	2213.00

HDX HEAVY-DUTY DEGREASER

- Low odour
- Quick penetration
- No rinsing
- No residue
- Non-conductive
- Heavy-duty action removes oil, grease, wax, dirt, moisture, tar, brake fluid and other contaminants
- NSF registered category code K1



Model No.	Mfg. No.	Size	Price /Each
AA840	C01020	19 oz.	14.00
AB446	C01005	5 gal.	518.00

ZEROTRI® HEAVY-DUTY DEGREASER

- Heavy-duty penetrating degreaser instantly removes oil, grease, wax, dirt, moisture, tar, conformal coatings and other contaminants
- No ozone depleting chemicals
- Fast evaporating, no rinsing, no residue
- Does not contain chlorinated solvents
- Safe to use on most surfaces
- Inverta spray valve
- NSF registered category code C1
- Accepted for use in Canadian food processing facilities



Model No.	Mfg. No.	Size	Price /Each
AA787	C03520	15 oz.	29.30
AB607	C03528	1 gal.	189.00
AB605	C03505	5 gal.	831.00
AB606	C03555	55 gal.	5980.00

A-151 SOLVENT DEGREASER

- High flash point above 140°F (60°C)
- Low odour
- No rinsing and no residue
- Non-conductive
- Safe to use on most surfaces
- NSF registered category code C1



Model No.	Mfg. No.	Size	Price /Each
AA920	C04320	15 oz.	27.00
AB448	C04305	5 gal.	650.00
AB579	C04355	55 gal.	5957.00

PRESOLVE® ORANGE DEGREASER

- High performance cleaner
- Non-conductive
- Natural-based solvent
- No rinsing and no residue
- Fast acting, deep penetration
- Safe on all metals and most plastics
- NSF registered category code C1



Model No.	Mfg. No.	Size	Price /Each
AA786	C01420	15 oz.	24.40
AD729	C01422	20 oz. Trigger	30.30
AB604	C01428	1 gal.	129.00
AB603	C01405	5 gal.	599.00
AA868	C01455	55 gal.	5995.00

HEAVY DUTY DEGREASERS

- Base Type: Chlorinated
- No flashpoint
- Fast evaporation rate
- A versatile cleaner/degreaser that is extremely effective in most heavy duty applications
- Aggressively dissolves grease, oil and sludge for more efficient operation of mechanical equipment
- Accepted for use in Canadian food processing facilities



Model No.	Mfg. No.	Size	Price /Each
YA184	73095	539 g	13.80

G-49™ LOW VOC ORANGE DEGREASER

- Complies with CARB/OTC/LADCO (California Air Resources Board/Ozone Transport Commission/Lake Michigan Air Directors Consortium) VOC regulations
- Instant cleaning action, no residue
- High solvent strength
- Moderate evaporation
- Not a hazardous air pollutant (HAP)
- Ideal for cleaning metals
- Inverta spray valve can be sprayed at almost any angle
- NSF registered category code C1



Model No.	Mfg. No.	Size	Price /Each
AD186	C06420	15 oz.	20.80

HYDROFORCE® INDUSTRIAL STRENGTH DEGREASER

- An aqueous cleaner that removes heavy deposits of grease, oil and dirt
- Biodegradable, concentrated, non-abrasive and non-flammable
- Use caution on soft metals and painted surfaces



Model No.	Mfg. No.	Size	Price /Each
AF112	74415	32 oz.	19.90

EFX SOLVENT /DEGREASER

- Heavy-duty solvent
- Instant degreasing action, quickly removes grease and oil
- Power blast spray
- Fast evaporating, no residue, non-chlorinated
- Safe to use on most surfaces
- Ideal for cleaning metals and most plastics



Model No.	Mfg. No.	Size	Price /Each
AD833	C01820	15 oz.	14.10

INSTANT SUPER DEGREASER 2.0

- Non-flammable fast drying solvent degreaser
- Heavy-duty formula that removes oil, grease, dirt, and tar with less cleaner
- Non-brominated formula that improves worker safety and simplifies employer compliance
- No residue/no rinsing formula
- Non-conductive formula that can be used on or near energized equipment, eliminating equipment downtime



Model No.	Mfg. No.	Size	Price /Each
AF141	C07220	20 oz.	54.00

EM-CITRO EMULSION DEGREASER

- Heavy-duty, citrus-based, aerosol degreaser that quickly removes oil/grease, tar, and grime from metal parts and equipment
- High delivery spray enhances and accelerates soil removal
- Wipe dry or rinse with water soil emulsifies and is removed easily by a strong stream of fresh water
- Neutral pH with no caustics, acids, chlorinated solvents, alcohols, or ozone depleting solvents
- Low foam viscous liquid enhances contact time by clinging to the soil & surface
- Safe on most surfaces
- Meets VOC regulations under CARB and the Ozone Transport Commission
- NSF registered category code C1



Model No.	Mfg. No.	Size	Price /Each
AD001	C02820	15 oz.	21.00
AD003	C02805	5 gal.	534.00
AD004	C02855	55 gal.	4437.00

BFX ALL-PURPOSE CLEANER

- Water-based
- Butyl-free and dye-free formula
- Removes grease and oil
- Rinses clean
- Ideal for parts washers and pressure washers
- Safe on most surfaces except magnesium
- NSF registered category code C1



Model No.	Mfg. No.	Size	Price /Each
AB581	C05528	28 oz.	15.00
AB584	C05501	1 gal.	30.80
AB582	C05505	5 gal.	144.00
AB583	C05555	55 gal.	1444.00

CITRUS CLEANER /DEGREASER

- Biodegradable, heavy-duty, multi-purpose cleaner and graffiti remover
- Pleasant citrus scent
- Removes grimy dirt, grease and oil
- For surfaces such as Formica fiberglass, wood, ceramic tile and some plastics
- Cleans residue on moulds, aluminum and concrete
- Ideal for public areas subject to abuse, such as restrooms, locker rooms, schools and buildings



Model No.	Mfg. No.	Size	Price /Each
AA111	A00751	16 oz.	14.50

HYDROFORCE® ZERO VOC GENERAL PURPOSE CLEANERS

- Plastic safe: Yes
- Slow evaporation rate
- Provides maximum regulatory compliance without performance compromises
- Removes dirt, dust, and grime
- Accepted for use in Canadian food processing facilities



Model No.	Mfg. No.	Size	Price /Each
AE970	74446	946 ml	18.70

PRECISION CLEAN MULTI-PURPOSE CLEANER/ DEGREASER

- Water-based
- Removes grease, oil, sludge, soot, ink, coffee, and more
- Contains no chlorinated or petroleum solvents, bleach, ammonia, abrasives or butyl
- Contains a corrosion inhibitor
- Super industrial-strength
- Safe on all surfaces
- NSF registered category code C1



Model No.	Mfg. No.	Size	Price /Each
READY TO USE FORMULA			
AB444	C02720	18 oz.	17.10
AA789	C02728	28 oz. trigger	19.60
CONCENTRATED FORMULA			
AA788	C02701	1 gal.	59.60
AB600	C02705	5 gal.	292.00
AB601	C02755	55 gal.	2132.00

SLAP SHOT™ CLEANER/ DEGREASER

- Industrial parts cleaner/degreaser
- Removes grease and oil
- Free of chlorinated solvent
- Safe on all metals
- Prepares surfaces for painting or relubrication
- Requires no rinsing, leaves no residues



Model No.	Mfg. No.	Size	Price /Each
YC419	53-C 502	500 ml	10.15
AC306	53-C 503	500 ml, trigger	17.75
AA462	53-C 506	5 L	83.65
AA463	53-C 507	20 L	374.75
AC307	53-C 508	200 L	1606.00

CHEMICALS

FOOD GRADE CITRUS CLEANER/DEGREASER

- D-Limonene is biodegradable
- Heavy-duty, multi-purpose cleaner and graffiti remover
- Removes grimy dirt, grease and oil
- Cleans residue on moulds, aluminum and concrete
- NSF Certified



Model No.	Mfg. No.	Size	Price /Each
AB532	A020454LQ	14 oz. trigger	17.40

FOOD GRADE STAINLESS STEEL CLEANER

- Polishes, brightens, cleans and protects stainless steel and metal surfaces
- Water-based emulsion
- Invisible coating resists fingerprints, watermarks and rusting
- Resists corrosion
- Cleans and shines
- Good for aluminum, porcelain and ceramic tile
- NSF Certified



Model No.	Mfg. No.	Size	Price /Each
AB536	A020885LQ	14 oz. trigger	11.50

FOOD GRADE GENERAL PURPOSE CLEANER

- All-purpose formula that cuts through dirt with ease
- Effective and safe to use on metal, finished wood, porcelain, vinyl, leather, laminated surfaces and glass
- Cleans spots on synthetic carpets
- For office equipment, copy machines, vehicle interiors, windshields, counters, chalkboards and fixtures
- NSF Certified



Model No.	Mfg. No.	Size	Price /Each
AB535	A020880LQ	14 oz. trigger	11.00

UNO S F CLEANER

- Non-flammable
- Concentrated cleaning power
- Contains corrosion inhibitors
- Solvent, phosphate and butyl-free
- For iron, steel, and stainless steel
- Removes oil, fat, grease, soot, wax and protein
- VOC free
- Accepted for use in Canadian food processing facilities



Model No.	Mfg. No.	Description	Price /Each
AA464	53-G 023	500 ml trigger	15.00
AA465	53-G 016	5 L Jug	53.55
AA466	53-G 017	20 L Pail	182.00
NI137	53-G 018	200 L Drum	1284.80

OCX™ CITRUS DEGREASER

- High performance industrial degreaser that cleans on contact
- Fast acting on grease, oil and sludge
- Natural based
- Does not contain chlorinated solvents
- Flash point above 100°F (38°C)
- Non-conductive
- Safe on all metals and most plastics
- Inverta spray valve
- Value Performance



Model No.	Mfg. No.	Description	Price /Each
AB588	C05020	15 oz. Aerosol	18.50
AB585	C05005	5 gal. Pail	418.00

WD-40® SPECIALIST™ INDUSTRIAL DEGREASER

- Solvent-based degreaser that quickly cleans machinery, engines and equipment to look like new and run smooth
- No residue
- Flashpoint: 202°F



Model No.	Mfg. No.	Size	Price /Each
AF177	012210	425 g	9.45

STAINLESS STEEL CLEANER

- Water-based emulsion
- Effectively cleans most water and oil-based stainon stainless steel and other metal surfaces
- Resists finger-prints, water marks and rusting
- USDA compliant, NSF Certified
- For kitchen equipment, drinking fountains, elevator doors and furniture



Model No.	Mfg. No.	Size	Price /Each
AA202	A00885	17 oz.	7.57

GENERAL PURPOSE CLEANER

- All-purpose formula cuts through dirt with ease
- Safe to use on metal, finished wood, porcelain, vinyl, leather, laminated surfaces and glass
- Cleans spots on synthetic carpets
- USDA compliant, NSF Certified
- For office equipment, copy machines, vehicle interiors, windshields, counters, chalkboards and fixtures



Model No.	Mfg. No.	Size	Price /Each
AA200	A00880	19 oz.	6.11

GLASS CLEANER

- Removes soil, smoke haze, fingerprints, road film and surface smears
- Cleans any surface not normally harmed by water
- USDA compliant, NSF Certified
- Will not cloud plexiglas or other plastic materials
- Resists streaking; wipes clean
- For windows, glass, mirrors, windshields, chrome, showcases, countertops, tile, vinyl upholstery and safety glass



Model No.	Mfg. No.	Size	Price /Each
AA201	A00888	18 oz.	6.11

SUPER CITRUS™ DEGREASERS

- Base type: d-Limonene and petroleum distillate
- Flashpoint: 43°C
- Fast evaporation rate
- Removes grease, oil and lubricants with no water wash-off
- Evaporates quickly and leaves no residue
- Pleasant citrus scent



Model No.	Mfg. No.	Size	Price /Each
AE967	73170	435 g	18.10

WORKPLACE HAND CLEANER TOWELS

- Waterless hand cleaner
- Deep cleaning, non-scratching abrasives
- Leaves hands clean, conditioned and softened
- 72 towels per bucket



Model No.	Mfg. No.	Price /Each
AA841	C09200	22.90

FIGHTBACK™ GRAFFITI REMOVER

- Safe and efficient, used to remove vandal marks leaving an undamaged original surface
- Ideal for use on brick, concrete, ceramic tiles, aluminum, steel, brass, chrome, vinyl, enamels, porcelain, marble slab, laminated plastic and most plastic surfaces
- Adequate for sprayed paint on vehicles and commercial trailers
- Breaks down and dissolves fresh stained molecules
- Spray it on, wait 30 to 60 sec. and wipe or spray with water
- Removes spray paint, indelible ink, grease, crayon, lipstick, black heel marks, etc.
- Very low toxicity
- No methylene chloride
- Non-flammable



Lloyds

Model No.	Size	Price /Each
AA529	350 g aerosol	12.10

CITRUS BASE CLEANER

- Heavy-duty degreaser/cleaner
- Safe on metals, ceramic, glass, porcelain and many plastics
- Removes grease, oil, ink and most adhesives
- No harmful solvents
- Cleans without streaking
- Non-aerosol pump



Model No.	Size	Price /Each
AA528	5 oz.	22.57
QN488	18.5 oz.	30.58

TRIFREE BRAKE CLEANER

- Heavy-duty performance
- Improves brake performance
- Helps stop disc brake squeal
- Fast evaporation
- Powerful jet spray
- No rinsing and no residue



Model No.	Mfg. No.	Size	Price /Each
AA818	C03620	15 oz.	23.00

ECO-GRADE™ VANDAL MARK & GRAFFITI REMOVER

- Soy based, contains natural, biodegradable ingredients made to replace terpene or petrochemical based products
- Formulated with EPA DFE certified materials
- Quickly and easily removes paint, ink, crayon, magic marker and adhesive residue
- Sprays and clings to vertical surfaces
- Penetrates and dissolves oil based stains quickly



Model No.	Mfg. No.	Size	Price /Each
AD402	A00404000	12 oz.	14.50

ELECTRA-X 2.0 CONTACT CLEANERS

- Non-flammable fast drying electronic cleaner
- Economical and effective industrial-strength formula
- Non-brominated formula that improves worker safety and simplifies employer compliance
- No residue/no rinsing formula
- Non-conductive formula
- Inverta spray valve allows users to spray in an upright or inverted position for more convenient application



Model No.	Mfg. No.	Size	Price /Each
AF143	C07316	12 oz.	39.70

NON-CHLORINATED BRAKE & PARTS CLEANER

- Non-chlorinated and fast evaporating
- Leaves no residue
- Instantly flushes away brake fluids, grease and dirt to ensure accurate adjustments and smooth brake operations
- Also recommended as a cleaner for metal parts
- Improves brake performance, helps stop break disc squeal



Model No.	Mfg. No.	Size	Price /Each
AA649	C00705000	14 oz.	6.58

COIL CLEANER

- Water-based, foaming coil cleaner
- Foaming and penetrating action
- Non-flammable and non-corrosive
- Safe on all types of metal
- Recommended use: All refrigerator and A/C coils, coolers, freezer engines, HVAC units, motors and machinery



Model No.	Mfg. No.	Size	Price /Each
AD056	A00887	18 oz.	6.55

CHLOR-FREE™ DEGREASER

- Non-chlorinated degreasing solvent that removes oil, grease and other types of contaminants
- Ideal for use in applications requiring quick turnaround and where a low flashpoint solvent can be used



Model No.	Mfg. No.	Size	Price /Each
AF105	73185	425 g	12.30

NOFLASH® 2.0 ELECTRO CONTACT CLEANERS

- Non-flammable fast drying electronic cleaner
- Industrial-strength formula for maximum cleaning power
- Non-brominated formula that improves worker safety and simplifies employer compliance
- No residue/no rinsing formula
- Non-conductive formula
- Inverta spray valve allows users to spray in an upright or inverted position for more convenient application



Model No.	Mfg. No.	Size	Price /Each
AF142	C07416	12 oz.	50.80

CHEMICALS

CFC FREE ELECTRO CONTACT CLEANER

- Fast evaporation
- No residue
- Low odour
- Non-conductive
- Safe on plastics
- Inverta spray valve allows you to spray in an upright or inverted position
- NSF registered category code K2



Model No.	Mfg. No.	Size	Price /Each
AA784	C03116	11 oz.	27.10
AB546	C03101	1 gal.	130.00
AB544	C03105	5 gal.	541.00
AB545	C03155	55 gal.	5449.00

CFC FREE NU CONTACT CLEANER

- Reduced VOC's (Volatile Organic Compounds) content and conforms to CARB (California Air Resources Board), OTC (Ozone Transport Commission) and LADCO (Lake Michigan Air Directors Consortium) VOC regulations
- Removes dirt, flux, moisture, dust, and other contaminants from electrical equipment
- Fast evaporating, safe on plastics
- Will not leave a residue
- NSF registered category code K2



Model No.	Mfg. No.	Size	Price /Each
AD177	C05416	11 oz.	27.80

REVO 66® CONTACT CLEANER

- Ideal for removing dirt, moisture, flux or oxides from the internal components of electronic equipment
- Non-flammable precision cleaning
- Does not contain brominated solvents
- Fast evaporating
- Non-conductive
- Quick penetration
- No rinsing and no residue
- Safe to use on most surfaces
- NSF registered category code K2
- Accepted for use in Canadian food processing facilities



Model No.	Mfg. No.	Size	Price /Each
AD010	C04416	12 oz.	39.60

ELECTRO 140° CONTACT CLEANER

- Flash point above 140°F (60°C)
- Superior wetting and penetrating action
- Controlled evaporation
- No residue • Non-conductive
- Safe to use on most surfaces
- Inverta spray valve allows you to spray in an upright or inverted position



Model No.	Mfg. No.	Size	Price /Each
AA836	C00916	11 oz.	22.40

NOFLASH® NU PRECISION CONTACT CLEANER

- Does not contain chlorinated solvents
- Non-flammable precision cleaning
- No flash point
- Fast drying
- Quick penetration and evaporation
- No rinsing and no residue
- Safe to use on most surfaces
- NSF registered category code K2



Model No.	Mfg. No.	Size	Price /Each
AA860	C04015	12 oz.	47.60

MICRO-X FAST EVAPORATING CONTACT CLEANER

- Fast evaporation
- Quick penetration
- No residue
- Low odour
- Safe on plastics
- No rinsing
- Inverta spray valve allows you to spray in an upright or inverted position



Model No.	Mfg. No.	Size	Price /Each
AA837	C04516	11 oz.	17.00
AB549	C04555	55 gal.	2932.00

QB PRECISION DUSTER

- Quick blast precision duster removes contaminants, dirt, dust and other soils
- Moisture free
- No residue
- No flash point
- Odourless



Model No.	Mfg. No.	Size	Price /Each
AA918	C05710	12 oz.	20.50

ELECTRO CONTACT CLEANER

- No ozone depletion potential
- Fast penetration
- Quick evaporation
- Penetrates into minute spaces
- Cleans/degreases delicate mechanisms
- Ideal for electrical/electronic fine parts
- Removes light greases, oils, dirt and organic soils
- No rinsing and no residue
- Safe to use on most surfaces



Model No.	Mfg. No.	Size	Price /Each
AA858	C00416	14 oz.	85.50

PSC PLASTIC SAFE CLEANER

- Formulated for contact cleaning
- Fast evaporation
- No flash point
- No rinsing and no residue
- Displaces moisture
- Very low odor
- No CFC's



Model No.	Mfg. No.	Size	Price /Each
AB700	C04620	18 oz.	85.50

LECTRA CLEAN® HEAVY-DUTY ELECTRICAL PART DEGREASER

- A chlorinated based degreaser that quickly removes grease, oil and dirt from motor parts and other similar equipment



Model No.	Mfg. No.	Size	Price /Each
AF103	72018	539 g	12.30

QD™ CONTACT CLEANER

- Plastic safe: Yes
- Flashpoint: Less than -18°C
- Very fast evaporation rate
- Suitable for cleaning sensitive electronics and electrical equipment
- Use where lower flashpoint cleaners are acceptable
- Accepted for use in Canadian food processing facilities



Model No.	Mfg. No.	Size	Price /Each
MLN874	72130	312 g	21.00

FREEZE SPRAY

- Plastic Safe: Yes
- No flashpoint
- Very fast evaporation rate
- Aerosol coolant system that instantly freezes surfaces to -60°F, dissipating heat and cooling equipment
- Assists in locating thermal intermittent components, failures and shorts
- Safe to use on sensitive components and all surfaces finishes



Model No.	Mfg. No.	Size	Price /Each
AE971	74086	284 g	23.80

NON-CHLORINATED ELECTRICAL DEGREASER

- Penetrates instantly to remove dirt, oil, grease and wax
- More thorough and faster than alkaline cleaners
- Safe on all ferrous and non-ferrous metals and most plastics
- Non-flammable, non-chlorinated, non-ozone depleting, fast evaporating
- Dielectric strength: 15 000 volts
- NSF registered category code K2



Model No.	Mfg. No.	Size	Price /Each
AB533	A020847LQ	14 fl oz. trigger	39.20

FLASH FREE SAFETY SOLVENT & DEGREASER

- Meets California's consumer regulation (CONS1) for energized electrical cleaner
- Fast-acting solvent penetrates easily, evaporates quickly, leaves no residue
- Excellent cleaning properties make it ideal for removing grease, dirt, wax and oil
- Non-conductive, non-flammable, fast evaporating, chlorinated
- Dielectric strength: 37 000 volts
- NSF registered category code K2



Model No.	Mfg. No.	Size	Price /Each
AB534	A020848LQ	14 fl oz. trigger	21.50

ENVIRONMENTAL CLEANER & DEGREASER

- Meets California's consumer regulation (CONS1) for energized electrical cleaner
- Designed for fast, effective removal of dirt, oil, grease, wax and tar
- For use on non-energized equipment
- Leaves no residue
- Fast-evaporating
- NSF registered category code K2



Model No.	Mfg. No.	Size	Price /Each
AB531	A0220749LQ	14 fl oz. trigger	15.10

DUSTERS

- Non-conductive
- Non-flammable
- Removes microscopic particles of lint, dust, ferrous oxide and other contaminants
- Useful on instruments where residual entrapment could be a problem
- High-delivery trigger valve
- Safe on plastics
- Non-abrasive
- For electronics, data processing, optical and laboratory equipment, personal computers and precision mechanical parts



Model No.	Mfg. No.	Size	Price /Each
AB934	A0200700	10 oz.	15.20

ENVIRONMENTAL CONTACT CLEANERS

- Heavy-duty degreaser and quick-drying cleaner
- Ideal for sensitive equipment and precision instruments
- Fast-evaporating
- Safe on most plastics
- Leaves no residue
- For use on non-energized equipment
- For printed circuits, office machines, vacuum tube parts and computer systems



Model No.	Mfg. No.	Size	Price /Each
AA214	80230Z	11 oz.	14.90

ENVIRONMENTAL CLEANER & DEGREASER

- Designed for fast, effective removal of dirt, oil, grease, wax and tar on electrical equipment
- For use on non-energized equipment
- Leaves no residue
- Fast-evaporating
- For electric motors, radar equipment, gears, brakes, clutches, generators, air tools and moulds



Model No.	Mfg. No.	Size	Price /Each
NA613	A00749	15 oz.	12.60

FLASH FREE SAFETY SOLVENT & DEGREASER

- Fast-acting solvent penetrates easily, evaporates quickly, leaves no residue
- Ideal for removing grease, dirt, wax and metallic particles
- Non-conductive
- Non-flammable
- Dielectric strength: 37 000 volts
- Includes extension tube and high-delivery nozzle for flush-type applications
- NSF registered category code K2



Model No.	Mfg. No.	Size	Price /Each
AA216	A20848	13 oz.	12.00

ANTI-STATIC SPRAY

- Neutralizes static electricity generated by friction or atmospheric conditions
- Proven effective on plastic, paper, cellophane, cloth and thread materials
- Dries instantly, non-staining
- Can be applied to machinery or parts in process
- Will not attract contaminants



Model No.	Mfg. No.	Size	Price /Each
AC517	A00610	11.5 oz.	15.20

7629™ ELECTRICAL CONTACT CLEANERS

- Ideal for removing grease, oil and contaminants from electrical parts to prevent contact failures
- Dries residue-free in seconds
- This contact cleaner is non-conductive, non-corrosive and non-flammable



Model No.	Mfg. No.	Size	Price /Each
AF070	1174633	12 oz.	33.90

CHEMICALS

LPS 1® GREASELESS LUBRICANT

- Dry, thin lubricating film
- Resists oil, dust and dirt build-up
- Fast acting penetration
- Displaces moisture
- Loosens rusted or frozen parts
- Provides short term, light, corrosion resistant barrier
- Safe on paint and most plastics
- Inverta spray valve lets you spray in all directions
- NSF registered category code H2
- Accepted for use in Canadian food processing facilities



Model No.	Mfg. No.	Size	Price /Each
AA819	C30116	11 oz.	18.40
AB628	C00122	20 oz. trigger	24.70
AB627	C01128	1 gal.	72.70
AB625	C00105	5 gal.	324.00
AB626	C00155	55 gal.	3073.00
AE950	C30144	7" x 10" Wipe	1.48

HIGH PERFORMANCE SILICONE LUBRICANT

- 6.6% silicone formula
- Stops squeaks and sticking, eliminates friction, repels water and prevents freezing
- Does not harden or degrade from -40°F to 400°F
- Apply to wood, metal, fabric, rubber or leather
- Keeps rubber soft and flexible
- For rubber mountings, weather-strip insulation, doors, locks, trunk lids, windows, slitter knives, any sliding surface



Model No.	Mfg. No.	Size	Price /Each
AA647	A01324	10 oz.	7.21

ALL-PURPOSE SILICONE LUBRICANT

- 5% silicone formula
- Reduces friction and sticking; protects against corrosion and oxidation with an invisible film that repels water
- Compatible with most surfaces; will not attack most plastics
- Will not interfere with painting or decorating
- Effective from -50°F to 375°F
- For rubber moldings, windows, sliding wood surfaces, sewing equipment, sliding racks, dissimilar metals, springs, leather, doors, hinges, weather-stripping, plastic assemblies



Model No.	Mfg. No.	Size	Price /Each
AA108	800206	10 oz.	6.63

HEAVY-DUTY SILICONE LUBRICANT

- Silicone-rich formula
- Water-based formula
- Colourless and odourless
- Excellent lubricity
- Eliminates sticking, binding and squeaking
- Dry, non-staining
- Safe on most surfaces
- Made of FDA compliant materials
- NSF registered category code H1
- Accepted for use in Canadian food processing facilities



Model No.	Mfg. No.	Size	Price /Each
AA844	C01516	13 oz.	18.10
AB624	C01505	5 gal.	451.00

FOOD PLANT SILICONE LUBRICANT

- Flashpoint: Less than -18°C
- Fast evaporation rate
- Multi-purpose silicone spray for food processing and handling applications
- Forms a colorless, odorless, non-staining film
- Eliminates binding and sticking in most metal to non-metal applications
- Accepted for use in Canadian food processing facilities



Model No.	Mfg. No.	Size	Price /Each
YC014	73040	284 g	15.50

SUPERIOR LUBRICANT

- Penetrates inaccessible areas to displace contaminants
- Lubricates with oils, additives and PTFE to reduce friction and increase part life
- Protects against moisture and corrosion damage; displaces moisture to prevent icing; inhibits rust formation and corrosive build-up
- Rejects dirt, dust, sand and other abrasive particles
- Resists rust and corrosion, even under extreme conditions
- Effective from -60°F to 475°F
- For bearings, cables, nuts and bolts, air power tools, ball and socket joints, control cables, conveyors, cutting tools, drive chains, electric power tools, gears, glides, hinges, linkages, precision tools, rollers, taps, dies and valves
- NSF registered category code H2



Model No.	Mfg. No.	Size	Price /Each
AA427	CTF20005	6 oz.	12.00
AA428	CTF20006	12 oz.	19.60
AA429	CTF20007	18 oz.	32.20

LPS 2® HEAVY-DUTY LUBRICANT

- Added corrosion protection
- Provides a nondrying, light, oily film for use on indoor /outdoor equipment
- Reduces wear caused by friction and corrosion
- Displaces moisture
- Loosens rusted or frozen parts
- Provides up to one year of protection
- Safe on paint and most plastics
- Inverta spray valve lets you spray in all directions
- NSF registered category code H2
- Accepted for use in Canadian food processing facilities



Model No.	Mfg. No.	Size	Price /Each
AA820	C30216	11 oz.	17.90
AB632	C00222	20 oz. trigger	24.40
AB631	C02128	1 gal.	76.50
AB629	C00205	5 gal.	343.00
AB630	C00255	55 gal.	3728.00

DRY GRAPHITE LUBES

- Dry black film
- Flashpoint: Less than -18°C
- Fast evaporation rate
- Resists dirt, dust and oil build-up
- Wide effective temperature range up to 850°F constant



Model No.	Mfg. No.	Size	Price /Each
MLT431	75101	320 g	13.00

SILICONE LUBRICANT

- Lubricates cutting tools and tables
- Prevents build-up of glues, wax, inks, paints
- Fast drying, long lasting, high quality
- Eliminates squeaks and sticking
- Contains no petroleum oils to stain fabrics
- Helps preserve plastic, rubber and leather
- Rubber mould release agent
- Temperature resistance: 350°F (177°C)



Model No.	Size	Price /Each
AA613	375 g	12.90

DRY FILM GRAPHITE LUBRICANT

- Ideal where a dry lubricant is or where petroleum products must be avoided
- Adheres with minimum pre-treatment
- Effective up to 850°F constant and 1000°F intermittent
- Dries rapidly at room temperature
- For pre-assembly lubrication of moving parts, mechanisms of vending machines and parking meters, automotive and industrial gaskets, bearings, locks, springs, hinges, mating surfaces on machines, CRT's, plating non-conductors, curing ovens



Model No.	Mfg. No.	Size	Price /Each
AA107	A00204	10 oz.	10.30

DRY FILM SILICONE LUBRICANT

- Colourless, thin film
- Excellent for releasing moulded parts in high temperatures or pressures
- Low odour
- Non-staining
- Non-flammable
- Non-corrosive



Model No.	Mfg. No.	Size	Price /Each
AA902	C01616	11 oz.	18.80

QTL DRY LUBRICANT WITH PTFE

- Dry, non-oily, non-staining lubricant
- Made with DuPont® Krytox®
- Dries quickly to a white, chemically inert film
- Effective from -40°F to 572°F
- Resists most solvents
- For metal extrusions, munitions, locks and catches, window guides, synthetic fibers, machine parts, cord, twine or rope, leather drawers, hinges, paper, glass, elastomers and some plastics
- Use as release agent on conveyor belts, chutes and slides, industrial blenders, tanks, bins and spray booths



Model No.	Mfg. No.	Size	Price /Each
AA184	800708	10 oz.	11.60

SYNTHETIC DRY PROTECTANT

- Quickly loosens rust while penetrating grease and dirt
- Transparent, non-staining oil
- Light film displaces moisture and acts as a corrosion preventative
- Jet stream sprays up to two feet for safe, accurate application
- Flashpoint: 205°F
- Will not harm painted surfaces
- For releasing rusted or frozen lugs and bolts, lubricating tight-fitting parts, general overhaul, repair work, food plant equipment
- NSF registered category code H2



Model No.	Mfg. No.	Size	Price /Each
AA227	A00737	11 oz.	11.10

DRY FILM PTFE LUBRICANT

- Ideal for releasing moulded parts
- Excellent for high temperature applications up to 500°F (260°C)
- Dry, thin film won't attract dust or dirt
- Non-flammable
- No silicone or chlorinated solvents
- Safe on most surfaces



Model No.	Mfg. No.	Size	Price /Each
AA870	C02616	11 oz.	19.90

DRY MOLY LUBRICANT

- Penetrates pores of substrate and bonds to surface for long-lasting lubrication
- High-pressure, high-solids molybdenum disulfide coating
- Withstands pressures up to 50 000 PSI
- Air dries in 5-10 minutes; cures in 2 hours at room temperature
- Maintains effectiveness under high temperatures (650°F constant and 750°F intermittent)
- For assembly and run-in lubrication, automotive and industrial gaskets, sliding surfaces and gears, chutes and bins, bearings, chain drives, intricate mechanisms, vending machines, parking meters, roller chains, conveyor belts where heat is present



Model No.	Mfg. No.	Size	Price /Each
AA104	800200	11 oz.	10.30

FORCE 842® DRY MOLY LUBRICANT

- Works under high temperatures up to 842°F (450°C) and pressures up to 100 000 PSI (6890 bars)
- Prevents seizure of parts
- High adhesion
- Resists dust and dirt
- Water and chemical resistant
- Provides a quick drying, thin film
- Not recommended for friction bearings or light-duty bearings



Model No.	Mfg. No.	Size	Price /Each
AA845	C02516	11 oz.	29.00

MAGNUM PREMIUM LUBRICANT WITH PTFE

- High performance lubricant with PTFE additives
- Ultra high lubricity
- Penetrates and protects metal against rust and corrosion
- Flash point of 175°F (79°C)
- Displaces moisture
- Safe to use on most surfaces
- Inverta Spray Valve lets you spray in all directions
- NSF registered category code H2



Model No.	Mfg. No.	Size	Price /Each
AA842	C00616	11 oz.	20.80

ECO-GRADE™ HIGH PERFORMANCE LUBE WITH PTFE

- Formulated with 100% natural soy oil and fortified with PTFE to offer excellent extreme pressure lubricity, water resistance and high temperature performance
- Contains no heavy metals
- Penetrate, water-displacer, rust inhibitor
- Equipped with spray Anyway™ valve and extension tube for hard to reach areas
- Best for use in high wear areas such as chains, cable, linkage, conveyor belts, industrial machines and more
- Surface to be protected should be clean, dry and free of rust, oil and mill scale



Model No.	Mfg. No.	Size	Price /Each
AD403	A00401000	12 oz.	15.40

CHEMICALS

FOOD GRADE SILICONE LUBRICANT

- Provides excellent lubrication
- Non-staining
- Non-corrosive
- Fast evaporating
- No chlorinated solvents
- Made of FDA compliant materials
- NSF registered category code H1
- Accepted for use in Canadian food processing facilities
- Metal and x-ray detectable plastic aerosol components
- Excellent for high temperature applications up to 500°F (260°C)



Model No.	Mfg. No.	Size	Price /Each
AA917	C01716	10 oz.	13.90

WD-40® SPECIALIST™ SILICONE LUBRICANT

- Safely lubricates, waterproofs and protects metal and non-metal surfaces, including rubber, plastic and vinyl
- Dries fast and leaves a clear, non-staining film that doesn't stick or make a mess
- Effective Temperature Range: -100°F to 500°F



Model No.	Mfg. No.	Size	Price /Each
AF172	01079	311 g	9.45

SILICONE LUBRICANT

- Effective from -58°F to 450°F
- Colourless, odourless low-viscosity lubricant
- Prevents sticking without transferring to end products
- Will not attack delicate surfaces such as styrene or urethane
- For slides, guide rails, knives, slicers, saws, grinders, dough mixers, guards, conveyors, food racks, ovens, bottling machines, heat sealing equipment, all food and drug processing equipment
- Made of FDA compliant materials
- NSF registered category code H1



Model No.	Mfg. No.	Size	Price /Each
AB519	A00210LQ	14 oz.	14.10

WHITE LITHIUM LUBRICANT

- Inhibits corrosion on unpainted metal surfaces
- High-solids, non-staining white grease
- Excellent for metal-to-metal applications
- Will not drip or run on vertical surfaces
- Effective from -20°F to 275°F
- For chains, gears, drives, hinges and other vertical or overhead surfaces
- NSF registered category code H2



Model No.	Mfg. No.	Size	Price /Each
AB513	A000100LQ	14 oz.	13.40

SILICONE LUBRICANT

- 5% silicone formula
- Colourless, odourless low-viscosity lubricant
- Prevents sticking without transferring to end products
- Will not attack delicate surfaces such as styrene or urethane
- For slides, guide rails, knives, slicers, saws, grinders, dough mixers, guards, conveyors, food racks, ovens, bottling machines, heat sealing equipment, all food and drug processing equipment
- NSF registered category code H1



Model No.	Mfg. No.	Size	Price /Each
AA110	A00210	10 oz.	5.54

SYNTHETIC FOOD GRADE OIL

- Includes PTFE for added lubricity
- Does not emulsify with water
- Waterproof
- Biodegradable
- Clear, non-staining
- Kosher approved
- For pumps, gear boxes, bearings, hydraulic systems, motors, chains, conveyors, general purpose lubrication
- NSF registered category code H1



Model No.	Mfg. No.	Size	Price /Each
AA525	TF23010	16 oz.	15.00

PLASTIC AND FOOD DON'T MIX



METAL DETECTABLE PLASTIC COMPONENTS



LPS® Laboratories has revolutionized food safety for manufacturers with the release of six NSF® H1 food grade lubricants with patent-pending DETEX™ metal detectable plastic components.



FOOD GRADE MACHINE OIL

- Penetrates to loosen frozen nuts and bolts
- Displaces water
- Provides excellent lubricity
- Does not contain silicone
- Eliminates sticking, binding and squeaking
- Non-staining lubricant, safe on most surfaces
- Inverts spray valve lets you spray in an upright or inverted position
- Made of FDA compliant materials
- NSF registered category code H1
- Accepted for use in Canadian food processing facilities
- Metal and x-ray detectable plastic aerosol components



Model No.	Mfg. No.	Size	Price /Each
AB623	C01316	11 oz.	15.50

FOOD GRADE MACHINERY OIL

- Economical, general-purpose lubricant
- Penetrates and loosens rust, dirt, scale and corrosion
- Non-silicone formula is excellent for use in areas where silicone overspray might interfere with carton sealing or capping operations
- Virtually odourless, tasteless and colourless
- For bottle and carton filling machinery, valves, pistons, rollers, stainless steel pumps, chain drive belts, paste and sauce fillers, cams on rotary-type fillers, mixers, conveyors
- NSF registered category code H1



Model No.	Mfg. No.	Size	Price /Each
AA139	800700	10 oz.	10.50

CHAINMATE® CHAIN & WIRE ROPE LUBRICANT

- Effective under extreme temperature and pressure ranges
- Fortified with molybdenum disulfide
- Deep penetration to the core of wire ropes
- High adhesion
- Lubricant and corrosion protectant
- Use with guards in place to eliminate costly down time
- Increases chain and wire rope life
- Reduces wear caused by friction and corrosion



Model No.	Mfg. No.	Size	Price /Each
AA877	C02416	11 oz.	22.10

MOLY CHAIN LUBRICANT

- Foaming action penetrates close tolerances of chain drive bushings and pins
- Specially formulated for all chain drive equipment
- Reduces wear, increases chain life up to three times when applied regularly
- Moly additive assures lubrication under extreme pressure
- Effective from -20°F to 300°F
- Excellent as a protective coating for stored metal parts
- For chain drives and pins, forklift trucks, tractors, machinery, workstand rollers, conveyors, motorcycle and bicycle chains, sprockets, clippers, cutter bars, chain saws, link and roller assemblies
- NSF registered category code H2



Model No.	Mfg. No.	Size	Price /Each
AA106	800202	12 oz.	7.34

WD-40® SPECIALIST™ SPRAY & STAY

- Offers long-lasting lubrication that won't run, drip or make a mess
- Gel stays where you spray it, making it ideal for use on vertical surfaces and moving parts like chains, cables, gears, rollers and bearings
- Safe on multiple surfaces including metal, plastic and rubber
- Effective Temperature Range: -100°F to 500°F



Model No.	Mfg. No.	Size	Price /Each
AF176	01221	425 g	12.90

FOOD GRADE CHAIN LUBRICANT

- Excellent for applications involving incidental food contact on food processing equipment
- Foaming action provides extra penetration and lubrication
- Oily, wet film extends chain life
- Low flammability with high flash point
- Reduces wear caused by friction
- NSF registered category code H1
- Accepted for use in Canadian food processing facilities
- Metal and x-ray detectable plastic aerosol components



Model No.	Mfg. No.	Size	Price /Each
AD731	C06016	12 oz.	20.20

OPEN GEAR & WIRE ROPE LUBRICANT

- Penetrates to core of wire rope, minimizing internal friction
- "Travels" on metal surfaces, displacing water to provide excellent rust protection
- Withstands extreme pressure with maximum adhesion
- Works from 0°F to 250°F
- Penetrates pores of surfaces without heating
- Will not wash, weather away or rub off
- Black colour aids in determining adequate coverage
- For open or exposed gears, wire rope winches, elevator cables, metal forming presses, wire rope, gear boxes, cable, roller chains, machine tools



Model No.	Mfg. No.	Size	Price /Each
AA105	800201	12 oz.	11.10

HEAVY DUTY OPEN GEAR & WIRE ROPE LUBRICANT

- Penetrates to core of wire rope, minimizing internal friction
- "Travels" on metal surfaces, displacing water to provide excellent rust protection
- Withstands extreme pressure with maximum adhesion
- Works from 0°F to 450°F
- Penetrates pores of surfaces without heating
- Won't wash, weather away or rub off
- Black colour aids in determining adequate coverage
- For open or exposed gears, wire rope winches, elevator cables, metal forming presses, wire rope, gear boxes, cable, roller chains, machine tools
- NSF registered category code H2



Model No.	Mfg. No.	Size	Price /Each
AB515	A000201LQ	14 oz.	17.50

FOOD GRADE MOLY CHAIN & PIN BUSHING LUBRICANT

- Specially formulated for all chain drive equipment
- Reduces wear, increases chain life up to three times when applied regularly
- Moly additive assures lubrication under extreme pressure
- Effective from -20°F to 300°F
- Excellent as a protective coating for stored metal parts
- For chain drives and pins, forklift trucks, tractors, machinery, workstand rollers, conveyors, motorcycle and bicycle chains, sprockets, clippers, cutter bars, chain saws, link and roller assemblies
- NSF registered category code H2



Model No.	Mfg. No.	Size	Price /Each
AB516	A000202LQ	14 oz.	14.80

CHEMICALS

DRY FILM PTFE MOLD RELEASE WITH KRYTOX®

- Made with DuPont® Krytox® dry film
- Non-silicone mould release
- Exceptional anti-stick properties that will not transfer to finished parts allowing for multiple releases per application
- Compatible with most mouldable resins, elastomeric compounds, urethanes and styrenes
- Will not attack rubber, paints or metals
- Recommended for low and high-temperature moulds up to 575°F
- For polystyrenes, polypropylenes, nylon, rubber, foams, metals, filament windings, polyurethanes, epoxy potting and encapsulating and phenolic resins
- NSF Certified



Model No.	Mfg. No.	Size	Price /Each
AA174	A00311	12 oz.	14.10

BELT DRESSING

- Does not contain 1,1,1 or any harmful, chlorinated solvents that deteriorate drive belts
- Low odour
- Prevents belt slippage on flat, round and V-belts
- Fast evaporation
- Eliminates squeaks from slipping belts
- Resists wash-off
- Extends belt life and pulley bearing life
- Can be used in wet outdoor conditions
- Made of FDA compliant materials
- NSF registered category code H1
- Accepted for use in Canadian food processing facilities
- Metal and x-ray detectable plastic aerosol components



Model No.	Mfg. No.	Size	Price /Each
AA869	C02216	10 oz.	16.10

YELLOW 77® WIRE PULLING LUBRICANT

- Wax-based formula provides superior lubricity
- Safe to use with most cable types except low-density polyethylene and semi-conducting jackets
- Clings to cable through long pulls
- Environmentally safe - non-toxic, non-flammable, non-corrosive
- Dries to a thin, non-conductive film that won't clog conduit



Model No.	Description	Price /Each
AB488	1 qt. Squeeze Bottle	13.10
AB489	1 gal. Tub	26.50

LONG TERM INDOOR PROTECTANT & LUBRICANT

- Non-staining, medium-weight oil formulated for long-term indoor protection
- Penetrates, displaces moisture and prevents rust
- Works up to 15 months against humidity and corrosion damage
- Leaves an amber film to identify coverage
- Contains no silicone or chlorinated solvents
- Safe to use on metals, rubber, and most plastic and painted surfaces
- Protects equipment stored indoors and items waiting to be shipped



Model No.	Mfg. No.	Size	Price /Each
AA228	A00767	11 oz.	12.00

COLOR GUARD® TOUGH RUBBER COATING

- Inhibits rust and corrosion
- Seals, insulates, and identifies almost any material in minutes
- Creates a non-slip gripping surface
- Rubber coating won't crack or chip
- Acid and alkali resistant
- Lasts for years
- Use to 200°F
- For dip, spray, or brush
- For tools, metal, electrical connections, masonry, wood, conveyors, glass, rope, fabric
- Toluene-free



LOCTITE

Model No.	Mfg. No.	Size	Colour	Price /Each
AC013	34979	14.5 oz.	Black	25.20
AC014	34980	1 gal.	Black	170.00
AC016	34982	14.5 oz.	Blue	25.20
AC017	34983	1 gal.	Blue	170.00
AC011	34985	14.5 oz.	Red	25.20
AC012	34986	1 gal.	Red	170.00
AC159	34988	14.5 oz.	Yellow	25.20
AC015	34989	1 gal.	Yellow	170.00

SF 7900™ CERAMIC SHIELD FOR WELDING

- Ceramic dry film protective coating for MIG/MAG welding processes
- Protects contact tips and welding nozzles by preventing adhesion of welding spatter
- Once applied the coating dries by solvent evaporation within 5 to 10 seconds at room temperature (Thicker films will need longer drying time)
- Ceramic, silicone-free protective coating, easy to apply
- Protects contact tips, welding nozzles and jigs, eliminating cost for cleaning equipment
- Reduces running costs for consumables by up to 40%
- Prevents adhesion of welding spatter for many hours with just one application
- Colour: White



LOCTITE

Model No.	Mfg. No.	Size	Price /Each
AD492	1616692	9.5 oz.	35.70

SF7607™ RUBBERIZED UNDERCOATING

- Heavy-duty undercoating seals, protects, and insulates
- Rubberized for maximum durability



LOCTITE

Model No.	Mfg. No.	Size	Price /Each
AA635	30538	16 oz.	7.90

3-IN-ONE® PENETRANT

- Fast-acting penetrant that quickly loosens stuck parts and prevents rust



3-IN-ONE

Model No.	Mfg. No.	Size	Price /Each
AD065	01040	311 g	4.36

RUST BREAKER™ PENETRANT

- Quickly loosens rust while penetrating grease and dirt
- Transparent, non-staining oil
- Light film displaces moisture and acts as a corrosion preventative
- Jet stream sprays up to two feet for safe, accurate application
- Flashpoint: 205°F
- Will not harm painted surfaces
- For releasing rusted or frozen lugs and bolts, lubricating tight-fitting parts, general overhaul, repair work, food plant equipment



Model No.	Mfg. No.	Size	Price /Each
AA113	A00103	10 oz.	9.65

TKX ALL-PURPOSE LUBRICANT

- Non-flammable CO₂ propellant
- Displaces moisture
- High flash point of 175°F (79°C)
- Protects against corrosion
- Loosens rusted or frozen parts
- Does not contain chlorinated solvents or silicones
- Safe on most surfaces
- Inverta spray valve lets you spray in all directions
- NSF registered category code H2
- Provides non-drying long-lasting, oily film



Model No.	Mfg. No.	Description	Price /Each
AA846	C02016	11 oz. Aerosol	9.01
AD730	C02022	20 oz Trigger	19.30
AB490	C02028	1 gal. Can	54.10
AB638	C02005	5 gal. Pail	295.00
AB639	C02055	55 gal. Drum	3064.00

5-WAY PLUS™ PENETRANT

- Penetrates, lubricates, demineralizes, cleans and prevents rust
- Inhibits corrosion and pitting of moulding dies and extension screws
- Frees rusted, frozen nuts and bolts
- Excellent for precision instruments
- Ideal for stainless steel and aluminum
- Displaces moisture in electrical apparatus, generators, motors
- Undercuts grit and grime on metal surfaces leaving a protective film



Model No.	Size	Price /Each
AA505	24 oz.	22.82

LST PENETRANT

- Specially formulated with low surface tension for fast penetrating action
- Attacks rust and corrosion to free frozen parts
- Powerful foaming action provides complete surface coverage
- Displaces moisture
- Lubricates and protects metal surfaces
- Flash point of 175°F (79°C)
- Inverta spray valve lets you spray in all directions
- NSF registered category code H2



Model No.	Mfg. No.	Description	Price /Each
AA843	C01916	11 oz. Aerosol	13.40
AB635	C01928	1 gal. Can	80.00

PENETRATING OIL

- Flashpoint: 60.6°C
- Slow evaporation rate
- A no-compromise penetrant that attacks corrosion to free corroded fasteners and mechanical components
- A super-fast, powerful, concentrated penetrating solvent that loosens and cleans
- Instantly penetrates tightly fitted crevices



Model No.	Mfg. No.	Size	Price /Each
YB991	73060	312 g	9.94

KB 88 THE ULTIMATE PENETRANT

- Quickly releases rusted and corroded nuts, bolts, hinges and other frozen components
- Extremely high solvency, low surface tension
- Enhanced penetration and lubrication
- Outperforms the competition in independent lab tests
- Penetrates faster and deeper than most other similar products in the market place
- VOC regulatory guidelines
- Inverta spray valve
- NSF registered category code H2
- VOC compliant



Model No.	Mfg. No.	Description	Price /Each
AD970	C02316	13 oz. Aerosol	17.30
AD297	C02322	20 oz. Trigger	23.30
AD971	C02301	1 gal. Can	119.00
AD972	C02305	5 gal. Pail	522.00

WD-40

- Loosens rusted parts
- Displaces moisture
- Non-conductor, dries out electrical and electronic equipment
- Stops squeaks
- Lubricates and protects against moisture and corrosive
- Operating temperature: -50°F to 300°F
- Minimum flash point 110°F open cup



Model No.	Description	Price /Each
NA611	311 g Aerosol	6.98
AF165	311 g Big Blast Aerosol	7.25
AF166	325 g Smart Straw Aerosol	9.95
AF168	591 ml Trigger Pro Bottle	13.50
AF169	408 g EZ-Reach™ Aerosol	13.50
NA609	3.78 L Can	36.20
AF170	18.9 L Pail	179.00
AA744	205 L Drum	1307.00
NA608	Spray Bottle Empty	6.74

WD-40® SPECIALIST™ RUST RELEASE PENETRANT

- Penetrates deep into crevices, threads and seams to break the bonds that hold stuck parts together
- Leaves behind a protective layer and helps prevent rust and corrosion from re-forming



SPECIALIST

Model No.	Mfg. No.	Size	Price /Each
AF171	01078	311 g	9.45

LB 8040 FREEZE & RELEASE

- Penetrating oil instantly freezes seized and rusted bolts, nuts and studs down to -45°F (-43°C)
- Shock-freeze effect of this penetrating oil causes microscopic cracks in the layer of rust, allowing the lubricating ingredient to wick directly into the rust by capillary action
- The rusted bolt assembly can be easily dismantled after allowing only 1-2 minutes penetration time
- Released parts remain lubricated and protected from corrosion
- Chemistry: Synthetics



Model No.	Mfg. No.	Size	Price /Each
AD133	996456	13.53 oz. aerosol	17.50

CHEMICALS

LPS 3® HEAVY-DUTY INHIBITORS

- Protects up to two years
- Stops rust and corrosion
- Provides non-sling lubrication
- Non-flammable propellant
- Self-healing, waxy film
- Provides anti-seize coating
- Safe to use on rubber, fabric, plastics and paints
- Meets or exceeds these specs: Boeing BMS-3 23F Type II, MIL-C-0083933A, para.3.2-3.16, MIL-C-16173D Grade 2 Class I, DMS 2150, Airbus TN A. 007.10138 Type I Grade 2
- Accepted for use in Canadian food processing facilities



Model No.	Mfg. No.	Size	Price /Each
AA808	C00316	11 oz.	23.50
AB559	C00322	20-oz. trigger	30.90
AB558	C03128	1 gal.	110.00
AB556	C00305	5 gal.	461.00
AB557	C00355	55 gal.	4549.00

BRIGHT COAT COLD GALVANIZE CORROSION INHIBITORS

- Shiny zinc coating
- Prevents rust and corrosion on all metals
- Restores hot dip galvanizing
- Dries to touch in 15 to 30 minutes
- Repairs rusted, galvanized and welded surfaces
- Electrochemically protects bare metal
- Heat resistant, flexible coating
- Will not yellow, chalk, crack or peel



Model No.	Mfg. No.	Size	Price /Each
AB485	C05916	13 oz.	16.60

BIO-RUST NEUTRAL PH RUST REMOVERS

- Removes rust and other metallic particles
- VOC free, solvent free, non-flammable, pH neutral solution biodegradable
- Not controlled under WHMIS
- Non-corrosive rust remover
- High workload - can remove 1.5 kg (3.3 lbs.) of iron oxide per 20 L
- For use with iron and mild steel
- Deeply rusted parts may require longer soaking time
- After application of Bio-Rust, rinse parts in water to remove loosened contaminants
- After removing rust, dip pack into fresh bath or Bio-Rust to provide short term corrosion protection
- It is recommended to degrease part before using Bio-Rust
- Bio-Rust is designed for immersion applications only
- Immerse parts in Bio-Rust at room temperature and let react for at least 30 minutes



WALTER
Surface Technologies

Model No.	Mfg. No.	Size		Price /Each
		Litres	Gallons	
AD441	53-G 247	20	5.2	347.95
AD442	53-G248	208	55	3105.00

EVAPO-RUST™ RUST REMOVERS

- Removes rust quickly without scrubbing
- Dipping process
- Non-toxic, non-corrosive, non-flammable
- VOC free
- Water-soluble, biodegradable, safe on skin
- Contains no acids, bases or solvents
- Will not harm unruined metals



Model No.	Mfg. No.	Size	Price /Each
AD049	ER1	1 L	10.80
AD050	ER4	3.78 L	32.10
AD051	ER20	18.9 L	155.00
AD052	ER205	205 L	1355.00

ZINC MATE™ INSTANT COLD GALVANIZED COATING

- Flashpoint: -19°C
- Fast evaporation rate
- Working Temperature: 54.4°C (Continuous) and 65.6°C (Intermittent)
- High performance coating of >93% pure zinc that electrochemically bonds with ferrous metals to form a galvanic cell
- Actively fights rust and corrosion
- Use as a touch-up for damaged galvanized coatings



Model No.	Mfg. No.	Size	Price /Each
YA185	73054	369 g	16.60

COLD GALVANISED CORROSION INHIBITORS

- 95% zinc-rich galvanised coating
- Commonly used as a flash rust preventative on welded areas
- Works like a hot-dip on ferrous metals indoors and out
- Three-year protection
- Withstands water temperature up to 212°F (100°C) and continuous dry heat up to 750°F (400°C)
- Flexible coating will not yellow, chalk, crack or peel
- Electrochemically protect bare metal
- Meets or exceeds these specs: MIL-P-46105 Weld Through Primer, Passes Preece Test for Hot-Dip Galvanizing



Model No.	Mfg. No.	Size	Price /Each
AA807	C00516	14-oz.	19.60
AB552	C05128	1 gal.	410.00

MAXI-COAT RUST INHIBITOR

- Heavy-duty coating that provides long-term protection for metal parts, equipment, and machinery
- Forms a protective, waxy film which seals out moisture, air, acid, and other corrosive elements
- Great for protecting parts in storage
- Container Type: Aerosol



LOCTITE

Model No.	Mfg. No.	Size	Price /Each
AA599	51211	16 oz.	15.10

COLD GALVANIZING COMPOUND

- 93% pure zinc coating provides maximum corrosion resistance and excellent adhesion and durability on galvanized metal
- Use to touch-up/repair galvanized ducts, storage tanks, fences, gutters, etc.
- VOC Compliant
- Finish: Gloss
- Max Operating Temperature: 200°F
- Series: Industrial Choice 1600



RUST-OLEUM

Model No.	Mfg. No.	Size	Price /Each
KP448	1685830	14 oz.	9.97

EXTEND® RUST TREATMENTS

- Goes on white and converts rust to a durable, black, metal-protective coating in 10 minutes
- Wirebrush parts and apply with brush or spray
- Surface rust must be present
- Use as a primer or finish coat
- Resists temperatures to 250°F intermittent, 200°F continuous
- Approved by the American Bureau of Shipping



LOCTITE

Model No.	Mfg. No.	Size	Price /Each
AA632	30539	10.5 oz.	13.30
AA633	75430	1 qt.	46.90
AA634	75448	1 gal.	162.00
AC110	75465	5 gal.	709.00

BRAKLEEN® BRAKE PARTS CLEANER

- Premium non-chlorinated brake parts cleaner that utilizes Powerjet® technology
- The spray nozzle produces a burst of product that forcefully breaks away contaminants, while the formula cleans and degreases instantly



Model No.	Mfg. No.	Size	Price /Each
AF115	75050	397 g	6.95

BATTERY TERMINAL PROTECTOR

- Dark Red Viscous Liquid
- Plastic Safe: Yes
- Flashpoint: Less than -18°C
- Specially designed to protect battery terminals from corrosion, a leading cause of hard starting and battery failure
- Provides a lead-free soft protective coating



Model No.	Mfg. No.	Size	Price /Each
AE952	75046	213 g	14.60

BATTERY CLEANER W/ACID INDICATOR

- Yellow Foam
- Plastic Safe
- Slow evaporation rate
- Instantly detects leaks and neutralizes acid
- Removes corrosion by-products
- Just spray on and rinse off



Model No.	Mfg. No.	Size	Price /Each
MLP160	75097	312 g	8.30

GASKET KLEEN™

- Plastic Safe: No
- Flashpoint: 13°C
- Fast evaporation rate
- Used for the removal of conventional and formed in place gaskets on motors, pumps and flanges



Model No.	Mfg. No.	Size	Price /Each
MLP071	75021	340 g	10.10

BRAKLEEN® BRAKE PARTS CLEANER

- The original brake parts cleaner
- Formulated to quickly & effectively remove grease, brake dust, brake fluids, oils, and other contaminants from brake parts, lining, and pads
- Plastic Safe: No
- Flashpoint: None
- Very fast evaporation rate
- Base Type: Chlorinated



Model No.	Mfg. No.	Bottle	Price /Each
MLP234	75089	539 g Aerosol	6.40
MLN591	75090	3.79 L Bottle	50.70

RUBBERIZED SPRAY UNDERCOATINGS

- Black Viscous Material
- Plastic Safe: No
- Flashpoint: 7°C
- Provides a tough, flexible shield against moisture, salt and road debris
- Dries quickly and is exceptionally resistant to abrasion



Model No.	Mfg. No.	Size	Price /Each
MLT298	75034	454 g	17.80

CLEAN-R-CARB® CARBURETOR CLEANERS

- Plastic Safe: No
- Flashpoint: -18°C
- Fast evaporation rate
- Designed to maximize carburetor performance
- Quickly dissolves carburetor deposits such as gum, sludge and varnish to improve fuel system performance and enhance fuel economy



Model No.	Mfg. No.	Size	Price /Each
MLP103	75081	454 g	8.41

3-IN-1® MOTOR OIL

- Special blend of high-grade oils that's equivalent to SAE 20
- Engineered for 1/4 HP motors or larger



Model No.	Mfg. No.	Size	Price /Each
AF178	01045	88.7 ml	3.95

BRAKLEEN® BRAKE PARTS CLEANER

- Formulated to quickly and effectively remove grease, brake fluid, oil and other contaminants
- Non-chlorinated formula
- Flashpoint: -18°C



Model No.	Mfg. No.	Description	Price /Each
MLP159	75088	397 g Aerosol	5.67
AF139	75086	19 L Pail	149.00

DIESEL FUEL THERAPY™ - DIESEL INJECTOR CLEANER W/ANTI-GEL

- Dark Amber Liquid
- Plastic Safe: No
- Flashpoint: 57°C
- Emissions reducing formula that is rated "SUPERIOR" in Cummins L-10 Test for injector cleanliness
- Lowers pour point & CFPP, reliquifies gelled fuel, adds lubricity, increases power and MPG



Model No.	Mfg. No.	Size	Price /Each
MLN925	75212	888 ml	17.60

ICE-OFF™ WINDSHIELD SPRAY DE-ICER

- Ideal for melting ice, snow and frost on contact
- Does not harm car finish
- Thaws frozen locks



Model No.	Mfg. No.	Size	Price /Each
AF119	75346	340 g	7.25

WD-40® SPECIALIST™ MACHINE & ENGINE DEGREASER

- Water-based formula produces deep foaming penetrating action
- Removes grease, oil, dirt and grime



Model No.	Mfg. No.	Size	Price /Each
AF174	02206	283 g	8.95

CHEMICALS

MARINE GRADE ANTI-SEIZE

- Protects assemblies exposed directly or indirectly to fresh and salt water
- Works especially well in high humidity conditions
- Excellent lubricity, superior water wash-out water spray resistance
- Prevents galvanic corrosion



LOCTITE

Model No.	Mfg. No.	Size	Price /Each
AC338	34395	8 oz.	28.40
TDP003	34026	16 oz.	39.50

FOOD GRADE ANTI-SEIZE

- Prevents seizure, galling and friction in stainless steel and other metal parts up to 750°F (399°C)



LOCTITE

Model No.	Mfg. No.	Size	Price /Each
AC339	1167237	8 oz.	28.40

HEAVY-DUTY ANTI-SEIZE

- Metal-free
- Excellent lubricity
- Outstanding lubrication to all metals including stainless steel, aluminum and soft metals up to 2400°F (1315°C)



LOCTITE

Model No.	Mfg. No.	Size	Price /Each
AC208	51605	9 oz.	43.30
AC328	51606	1.2 lb.	64.60

SILVER GRADE ANTI-SEIZE

- Heavy-duty, temperature resistant, petroleum-based lubricant
- Fortified with graphite and metallic flake
- Inert, will not evaporate or harden in extreme cold or heat
- For use in assemblies up to 1600°F (871°C)



LOCTITE

Model No.	Mfg. No.	Size	Price /Each
AC347	76732	8 oz.	21.10
YA275	76759	12 oz. aerosol	22.00
YA276	76764	1 lb.	28.10

COPPER ANTI-SEIZE

- Service rating: -65°F (-54°C) to 1800°F (982°C)
- Lead free, low friction lubricant in a water-resistant grease fortified with anti-oxidants
- Protects against seizure, heat-freeze, galling, rust and corrosion
- Permits reuse of fittings, saves stud, bolt and nut replacements
- Not affected by contraction, expansion or vibration
- Will not run, drip or settle out
- Copper colour



Model No.	Mfg. No.	Size	Price /Each
AA890	C02916	12 oz.	28.10
AA925	C02908	1/2 lb.	22.70
AA874	C02910	1 lb.	35.60

C5-A® COPPER BASED ANTI-SEIZE

- Suspends copper and graphite in a high quality grease
- Protects metal parts from rust, corrosion, galling, and seizing at temperatures to 1800°F (982°C)



LOCTITE

Model No.	Mfg. No.	Size	Price /Each
AC345	51147	8 oz.	20.70
AA533	1786073	12 oz. aerosol	28.60
AB467	51007	1 lb.	30.20

NICKEL ANTI-SEIZE

- Copper-free
- Recommended for stainless steel and other metal fittings
- For preventing corrosion, seizing and galling in harsh, chemical environments
- For temperatures to 2400°F (1315°C)



LOCTITE

Model No.	Mfg. No.	Size	Price /Each
AC337	77124	8 oz.	32.40
AB486	1852753	12 oz. aerosol	39.30
AA117	77164	1 lb.	43.10

ANTI-SEIZE QUICKSTICKS™

- Used in high temperature applications, Loctite®
- Provides exceptional lubrication as well as protection against rust, corrosion, seizing and galling
- Also reduce friction and wear of critical parts that can be easily disassembled when needed
- Sticks offer less mess and portability

Typical applications:

- Use with copper, brass, cast iron, and all alloys including stainless steel, all plastics, and all non-metallic gasket materials
- Bolts, bushings, pipes, fittings, flanges, gaskets, headers, manifolds, studs, etc.
- High heat ovens, crane assemblies, turbine studs, coal crushers, casting and moulding equipment, and heat exchangers

Model No.	Mfg. No.	Format	Grade	Price /Each
AB653	37229	20 g	Copper	9.14
AB654	37230	20 g	Silver	9.14



ALL-PURPOSE ANTI-SEIZE

- Service rating: -65°F (-54°C) to 1800°F (982°C)
- Moly-fortified
- Lead free
- Protects against seizure, heat-freeze, galling, rust and corrosion
- Lowers friction and reduces wrench torque
- Not affected by contraction, expansion or vibration
- Will not harden, evaporate or settle out and requires no thinning
- Steel blue colour



Model No.	Mfg. No.	Size	Price /Each
AA924	C04108	1/2 lb.	16.50
AB475	C04110	1 lb.	24.40
AE671	C04105	5 gal. Pail	893.00

NICKEL ANTI-SEIZE

- Service rating: -65°F (-54°C) to 2600°F (1427°C)
- Contains no lead, copper, graphite, chlorides, phosphorous, silicone or halogens
- Can be used with ammonia, acetylene and vinyl monomers, which are unstable in the presence of copper
- Protects against seizure, rust and corrosion
- Safe on stainless steel when temperatures exceed 550°F (288°C)
- Prevents water wash-off
- Will not run, drip or settle out
- Silver colour



Model No.	Mfg. No.	Size	Price /Each
AA926	C03908	1/2 lb.	29.90
AB637	C03910	1 lb.	57.40

LOCTITE



PISTOL GREASE GUNS

HEAVY-DUTY

- Designed for use in general confined spaces or where access to grease nipples is restricted
- Heavy-duty die cast grease gun head
- Develops 5000 PSI
- Capacity: 14 oz (400 g) grease cartridge or suction fill
- AC475 comes complete with 4" steel extension and 4-jaw coupler with ball check
- AC476 comes complete with 18" flexible hose and 4-jaw coupler with ball check

Model No. AC475

Price/Each \$27.95

Model No. AC476

Price/Each \$35.65



FOR OUR COMPLETE LINE OF GREASE GUNS, SEE PAGES 996 - 997

aurora tools

THERMAPLEX® MULTI-PURPOSE BEARING GREASE



- Excellent load carrying properties
- Prolongs bearing life
- Ideal for lubricating all types of bearings
- Blue coloured paste
- Petroleum odour
- Temperature range: -22°F (-30°C) to 350°F (177°C)
- Dropping point: 429°F (220°C)
- NLGI Grade: No. 2
- Lithium complex



Model No.	Mfg. No.	Size	Price /Each
AA847	C70614	400 g	10.10
AB620	C70606	5 gal.	450.00

THERMAPLEX® AQUA BEARING GREASE



- Resists water washout
- Excellent corrosion resistance
- Significant load carrying capability
- Greater degree of bearing protection
- Amber coloured paste
- Petroleum odour
- Temperature range: -4°F (-20°C) to 302°F (150°C)
- Dropping point: 500°F (260°C)
- NLGI Grade: No. 2
- Aluminum complex



Model No.	Mfg. No.	Size	Price /Each
AA851	C70514	400 g	10.10

THERMAPLEX® HI-LOAD BEARING GREASE



- Withstands shock loading
- Reduces wear from vibration
- Excellent anti-wear properties
- Wide operating temperature range
- Blue/black colour paste
- Lithium complex
- Petroleum odour
- Moly-fortified for extreme applications
- Temperature range: -22°F (-30°C) to 350°F (177°C)
- Dropping point: 429°F (220°C)
- NLGI Grade: No. 2



Model No.	Mfg. No.	Size	Price /Each
AA850	C70414	400 g	13.40
AB614	C70406	5 gal.	551.00

THERMAPLEX® FOODLUBE BEARING GREASE



- Metal & X-ray detectable plastic component
- Ensures safety in areas where incidental food contact may occur
- Does not contain, solvents or silicone
- Non-staining and non-emulsifying
- White coloured paste
- Mild odour
- Aluminum complex
- Temperature range: -4°F (-20°C) to 302°F (150°C)
- Dropping point: 500°F (260°C)
- NLGI Grade: No. 2
- Made of FDA compliant materials
- NSF registered category code H1
- Accepted for use in Canadian food processing facilities



Model No.	Mfg. No.	Size	Price /Each
AA852	C70114	400 g	15.90
AB611	C70106	5 gal.	684.00

THERMAPLEX® HI-TEMP BEARING GREASE



- Resists carbonization at high temperatures
- Extends relubrication intervals
- Reduces risk of bearing failure at high temperature
- Ensures optimal production rates
- Smooth, brown paste
- Petroleum odour
- Lithium complex
- Temperature range: -15°F (-26°C) to 392°F (200°C)
- Dropping point: 536°F (280°C)
- NLGI Grade: No. 2



Model No.	Mfg. No.	Size	Price /Each
AA848	C70214	400 g	19.00
AB617	C70206	5 gal.	857.00

THERMAPLEX® CS MOLY BEARING GREASE



- Excellent oxidation stability, adhesive and cohesive properties and corrosion resistance
- Exceptional water resistance
- Premium performance
- Calcium sulfonate grease
- Contains molybdenum disulfide
- Reduces wear from vibration
- High load carrying capacity
- Prolongs bearing life
- Wide operating temperature range: 0°F to 425°F (-18°C to 218°C)
- Extends re-lubrication intervals for bearings
- NLGI No. 2
- NSF registered category code H2



Model No.	Mfg. No.	Size	Price /Each
AD179	C70814	400 g	14.60
AD180	C70806	35 lbs.	569.00

Ask us about volume prices!



In many cases you will benefit from quantity prices.

CHEMICALS

RED & REDI MULTI-PURPOSE RED GREASE

- Delivers excellent lubrication
- Prevents rust, corrosion and oxidation
- Remains effective at extremely high temperatures
- Reduces friction and vibration
- Resists shock
- Red colour allows easy visual inspection
- Penetrates quickly
- Non-melting



Model No.	Mfg. No.	Size	Price /Each
AA873	C05816	11 oz.	16.40

CLEAR PENETRATING GREASE

- Protects against corrosion
- Resists water washout
- Quick penetrating action
- High tack
- Metal detectable plastic components-DETEX™



Model No.	Mfg. No.	Size	Price /Each
AD479	C06716	11 oz.	18.30

WHITE LITHIUM GREASE W/PTFE

- Rapidly forms into a pure white grease
- Heat and water resistant
- Produces a long lasting, protective film against rust and corrosion
- White colour allows easy visual inspection
- Does not contain any chlorinated solvents
- Accepted for use in Canadian food processing facilities



Model No.	Mfg. No.	Size	Price /Each
AA914	C03816	10 oz.	17.20

VIPERLUBE™ HIGH PERFORMANCE SYNTHETIC GREASE

- Grease provides superior protection against equipment exposed to a wide range of operating temperatures and environments
- Use as a lubricant and protective anti-rust film on bearings, machine parts, equipment, or as a release agent on gaskets and seals
- Temperature resistance: 400°F (204°C) continuous
- NLGI Grade: 2/Severe Duty GC-LB
- NSF registered category code H1
- Accepted for use in Canadian food processing facilities



LOCTITE

Model No.	Mfg. No.	Size	Price /Each
AB505	36781	3 oz. Tube	8.56
AB508	36782	14 oz. Cartridge	16.10
AB507	36783	400 g. Can	22.60
AE853	1906102	10.1 oz. Aerosol	11.10
AB509	37061	30 lbs. Pail	479.00

DIELECTRIC GREASE

- Moisture proof barrier that lubricates and protects electrical equipment from salt, dirt, and corrosion
- High dielectric strength
- Good thermal, oxidation and chemical stability
- Temperature resistance: 400°F (204°C) continuous



LOCTITE

Model No.	Mfg. No.	Size	Price /Each
AC365	30536	0.33 oz.	6.15

WHITE LITHIUM GREASE

- For metal-to-metal and metal-to-plastic applications
- Corrosion protection
- No ODC's
- Temperature resistance: 380°F (193°C) dropping point



LOCTITE

Model No.	Mfg. No.	Size	Price /Each
AA611	30530	1.5 oz. tube	3.99
AE854	1906122	10.75 oz. Aerosol	9.05

WD-40® SPECIALIST™ WHITE LITHIUM GREASE

- Sprays on evenly as a liquid and sets dry for a thick, protective coating
- Won't freeze, melt or run off



WD-40

SPECIALIST

Model No.	Mfg. No.	Size	Price /Each
AF173	01080	311 g	9.45

MULTI-PURPOSE CONCRETE REPAIR & ADHESIVE

- Excellent for bridging horizontal or vertical cracks, even under water
- Twice as strong as concrete
- Works on concrete, masonry, brick, steel and more
- For indoor or outdoor use
- Colour: Light Gray



RUST-OLEUM

Model No.	Mfg. No.	Size	Price /Each
KP497	257395	9 oz.	56.20
KP498	257397	Replacement Static Mixers - 3 Pack	15.90
AF183	261292	Heavy-Duty 9 oz. Caulking Gun	52.40

TURBOKRETE CONCRETE PATCH COMPOUND KITS

- Easily repair deep holes and cracks
- 100%-solids epoxy patch kit is designed for floors exposed to heavy traffic and intermittent chemicals
- Protects against abrasion, impact and most chemicals—no sealer required
- Creates an extremely hard surface—3-4 times stronger than concrete
- For interior/exterior use on damaged or severely spalled floors, curbs, ramps, etc.
- Odorless
- Easy-mix kit includes base, activator and aggregate
- Colour: Light Gray



RUST-OLEUM

Model No.	Mfg. No.	Size	Price /Each
KP495	253479	2 gal.	119.00
KP496	5494323	3.5 gal.	231.00

WHITE LITHIUM GREASE

- Inhibits corrosion on unpainted metal surfaces
- High-solids, non-staining white grease
- Excellent for metal-to-metal applications
- Will not drip or run on vertical surfaces
- Effective from -20°F to 275°F
- For chains, gears, drives, hinges and other vertical or overhead surfaces
- Recommended for use on knock-out pins on mould equipment
- NSF registered category code H2



Model No.	Mfg. No.	Size	Price /Each
AA103	A00100	11 oz.	9.20

BIG FOOT™ PRIMER/SEALER

- Specially formulated to increase adhesion and coverage of all Big Foot™ Anti-Slip Coatings except Acrylic Pedestrian Grade and Glow Coat
- For use on concrete, wood, tile, and other porous substrates
- Water-based
- 320 sq. ft. coverage
- Maximum temperature 140°F
- 120 minutes working time
- 3-6 hours, functional cure



LOCTITE

Model No.	Mfg. No.	Size	Colour	Price /Each
AA609	1617851	1 gal.	Clear	267.00

BIG FOOT™ VEHICULAR GRADE

- Withstands even the heaviest rolling equipment traffic
- Resists liquids as harsh as jet fuels and hydraulic fluids
- Superior adhesion forms a solid bond to metal, concrete, and wood
- 40 sq. ft. coverage per gal.
- Max. temperature 140°F
- 120 minutes working time
- 12/72 hours, functional cure



LOCTITE

Model No.	Mfg. No.	Size	Colour	Price /Each
AA605	1602678	1 gal.	Black	207.00

BIG FOOT™ ANTI-SLIP FLOOR COATINGS

HEAVY-DUTY PEDESTRIAN GRADE

- Fire retardant when cured
- For areas with heavy pedestrian or light rolling traffic
- Ideal for ramps, walkways, locker rooms, stairs, and assembly areas
- 50 sq. ft. coverage per gal.
- Max. temperature 140°F
- 12/72 hours, functional cure



LOCTITE

Model No.	Mfg. No.	Size	Colour	Price /Each
AA603	1602679	1 gal.	Black	165.00
AA604	1602121	1 gal.	Grey	165.00
AF069	1592315	1 gal.	Yellow	166.00

FIXMASTER® MAGNA-CRETE®

- Two-component, rapid setting concrete repair and grouting system
- Chemically resistant to most common liquids and chemicals
- For concrete, wood, glass, steel, and other construction materials
- 4.8 sq. ft. coverage
- Pourable
- Max temperature 2000°F
- 15 minutes working time
- 1-2 hours, functional cure
- Accepted for use in Canadian food processing facilities



LOCTITE

Model No.	Mfg. No.	Size	Colour	Price /Each
AA748	95551	1 gal.	Grey	108.00
AD917	95555	5 gal.	Grey	220.00

FIXMASTER® DEEP POUR GROUT

- Aggregate-filled, epoxy system for pours up to 6" deep
- For self-leveling applications under rails and sole plates
- Bonds to steel, concrete, and itself
- Withstands high torque loading
- 660 cu.in. of coverage
- Pourable
- Maximum temperature 225°F
- 30 minutes working time
- 24 hours, functional cure
- Accepted for use in Canadian food processing facilities



LOCTITE

Model No.	Mfg. No.	Size	Colour	Price /Each
AA745	99545	5 gal.	Black	323.00

LOCTITE® FIXMASTER® MAGNA-GROUT™

- A two-component, rapid-setting concrete repair and grouting system with same properties as the Magna-Crete™ but containing smaller aggregate so that the mixed material can be poured thinner for resurfacing applications and feather edging.



LOCTITE

Model No.	Mfg. No.	Size	Price /Each
AE625	1477097	1 gal.	95.20
AE626	1476710	5 gal.	194.00

ACRYLIC URETHANE FLOOR PAINT

- Convenient, high-gloss, water-based coating is ideal for use in mild industrial or commercial setting
- Protects concrete floors from dusting, water damage, staining and mildew
- Paint and go—no measuring or mixing; minimal surface prep
- Dries fast—accepts next-day foot traffic
- Finish: High Gloss



RUST-OLEUM

Model No.	Mfg. No.	Size	Colour	Price /Each
KP490	251286	1 gal.	Safety Yellow	74.30
KP491	251291	1 gal.	Silver Grey	74.30
KP492	251293	5 gal.	Silver Grey	368.00

FIXMASTER® FLOOR FILL

- Trowelable
- For repairing and resurfacing cracks in concrete floors
- Bonds to old and new concrete and provides greater strength and chemical resistance
- 133 cu.in. of coverage
- Semi-pourable
- Max temperature 225°F
- 40 minutes working time
- 24 hours, functional cure



LOCTITE

Model No.	Mfg. No.	Size	Colour	Price /Each
AC362	99361	10 lbs.	Grey	142.00
AA747	99365	40 lbs.	Grey	389.00

WATER-BASED SINGLE COMPONENT ACRYLIC FLOOR COATING

- General purpose
- 100% acrylic
- Low odour
- For exterior/interior use
- Dries rapidly to a tough, alkali resistant finish which will withstand hard wear, abrasion, grease, oils, and cleaning equipment
- For use over prepared concrete and wood floors, steps, stairwells, aisleways, or previously painted floor surfaces in sound condition
- Not recommended for areas subject to hot tire pickup



KRYLON INDUSTRIAL

Model No.	Size	Colour	Price /Each
AC603	1 gal.	Grey	76.10
AC606	5 gal.	Grey	380.00

CHEMICALS

SPOTCHECK® AEROSOLS

SKL-SP1 SPOTCHECK® PENETRANT

- Post emulsifiable penetrant
- Most widely used, general purpose
- Solvent removable

SKD-S2 SPOTCHECK® DEVELOPER

- Non-chlorinated solvent developer
- Meets major requirements for special alloy and nuclear applications

SKC-S SPOTCHECK® CLEANER

- Non-chlorinated cleaner/remover
- Recommended general purpose
- Meets major requirements for special alloy and nuclear applications



MAGNAFLUX®

Model No.	Mfg. No.	Description	Price /Each
NP701	01-5149-68	SKL-SP1 Penetrant	24.00
NP702	01-5352-68	SKD-S2 Developer	23.50
NP703	01-5750-68	SKC-S Cleaner	19.40

FORM-A-THREAD®

STRIPPED THREAD REPAIR KIT

- Permanently repairs stripped threads and fasteners in 5 minutes
- Allows up to 128 lbs. of torque
- Operating temperature between -65°F & 300°F
- Accepted for use in Canadian food processing facilities



LOCTITE

Model No.	Mfg. No.	Size	Price /Each
AA458	28654	4.8 ml	22.50

PIPE REPAIR KITS

- Urethane impregnated fiberglass tape, activated by water, for reliable, temporary repairs of metal, plastic, and composite pipes
- Cures in 30 minutes
- Includes: Loctite® Fixmaster® Metal Magic Steel™ epoxy stick, urethane impregnated fiberglass tape, and gloves
- Accepted for use in Canadian food processing facilities



LOCTITE

Model No.	Mfg. No.	Size	Price /Each
AA641	96321	2" x 6' tape	65.40

FIXMASTER® STEEL PUTTY

- Steel filled, non-sagging, two-part epoxy that cures to a metal-like finish for rebuilding or repairing metal parts
- 0.3 sq.ft. coverage, at 1/4" thickness
- 225°F maximum operating temperature
- 4900 PSI tensile strength
- 30 minutes working time
- Functional cure in 6 hours
- Accepted for use in Canadian food processing facilities
- Colour: Grey



LOCTITE

Model No.	Mfg. No.	Size	Price /Each
AC341	99913	1 lb. kit	63.20

FIXMASTER® ALUMINUM PUTTY

- Rebuilds and repairs aluminum equipment, forming a non-rusting finish
- 0.5 sq.ft. coverage, at 1/4" thickness
- 225°F maximum operating temperature
- 4000 PSI tensile strength
- 20 minutes working time
- Functional cure in 6 hours
- Accepted for use in Canadian food processing facilities
- Colour: Aluminum



LOCTITE

Model No.	Mfg. No.	Size	Price /Each
AC334	97463	1 lb. kit	87.70

FIXMASTER® STAINLESS STEEL PUTTY

- Forms a non-rusting, very hard, durable finish on damaged stainless steel surfaces
- 0.25 sq.ft. coverage, at 1/4" thickness
- 225°F maximum operating temperature
- 4600 PSI tensile strength
- 20 minutes working time
- Functional cure in 6 hours
- Accepted for use in Canadian food processing facilities
- Colour: Grey



LOCTITE

Model No.	Mfg. No.	Size	Price /Each
AC332	97443	1 lb. kit	98.60

Can't find what you're looking for?
Call us today!



FIXMASTER® STEEL LIQUID

- Steel filled
- Pourable and self-leveling
- Recommended for casting into hard to reach areas, anchoring and leveling, and forming moulds and fixtures
- 13 in.³ coverage, at 1/4" thickness
- 225°F maximum operating temperature
- 6000 PSI tensile strength
- 25 minutes working time
- Functional cure in 6 hours
- Accepted for use in Canadian food processing facilities
- Colour: Grey



LOCTITE

Model No.	Mfg. No.	Size	Price /Each
AC340	97483	1 lb. kit	68.70

FIXMASTER® ALUMINUM LIQUID

- Two-part, pourable epoxy system heavily reinforced with aluminum powder
- For casting and repairing of aluminum parts, and for making molds and fixtures
- 17 in.³ coverage, at 1/4" thickness
- 200°F maximum operating temperature
- 6000 PSI tensile strength
- 20 minutes working time
- Functional cure in 6 hours
- Accepted for use in Canadian food processing facilities
- Colour: Aluminum



LOCTITE

Model No.	Mfg. No.	Size	Price /Each
AC333	97453	1 lb. kit	89.30

FIXMASTER® FAST CURE POXY PAK™ EPOXY

- Bonds virtually any material to repair, fill, and seal holes, cracks, and worn surfaces
- 300°F temperature resistance
- 2300 PSI adhesive tensile shear
- 1 minute working time
- Fixtures in 4-6 minutes
- Full cure in 1 hour
- Colour: Clear



LOCTITE

Model No.	Mfg. No.	Size	Price /Each
AA739	1324007	1 oz.	8.51

FIXMASTER® FAST CURE EPOXY MIXER CUPS

- Excellent chemical resistance
- Fills porosities and can be used to build up worn parts
- For bonding glass, hard plastics, rubber, and metal
- 180°F temperature resistance
- 2000 PSI adhesive tensile shear
- 5 minutes working time
- Fixtures in 10 minutes
- Full cure in 12 hours
- Colour: Grey



LOCTITE

Model No.	Mfg. No.	Size	Price /Each
AC124	21425	10 x 4 g	43.20
AC125	21426	10 x 1 oz.	121.00
AB951	39088	4 x 4 g	23.40

LOCTITE® 2000 PUTTIES

- Tensile Strength on Grit Blasted Steel: 675 PSI
- A self-leveling aluminum liquid that can be poured into molds and cavities
- Recommended for casting aluminum replacement parts and for making molds
- Is paintable and sandable



LOCTITE

Model No.	Mfg. No.	Size	Price /Each
AB739	95724	8 oz.	102.00

FIXMASTER® FAST SET STEEL PUTTY

- Faster setting version of the Loctite® Fixmaster® steel putty
- Sets in 3 minutes
- Accepted for use in Canadian food processing facilities



LOCTITE

Model No.	Mfg. No.	Size	Price /Each
AD012	39917	1 lb.	74.20

LOCTITE® FIXMASTER® METAL MAGIC STEEL™

- Kneadable, two-part paste
- Working time: 3 minutes
- Sets in 10 minutes
- Adheres to damp surfaces
- Can be drilled, filed and painted
- Ideal for emergency sealing of leaking tanks and pipes
- Smooths welds, repairs small cracks in castings and fills oversized bolt holes
- NSF/ANSI 61 certified



LOCTITE

Model No.	Mfg. No.	Size	Price /Each
AD915	98853	4 oz.	20.00

LOCTITE® FIXMASTER® CONCRETE REPAIR EPOXY

- Enables permanent repairs to concrete and masonry
- Convenient stick contains premeasured portions of activator and base
- Once cured, it can be tapped, drilled, screwed, sawed, filed or painted and will have an appearance and texture similar to concrete



LOCTITE

Model No.	Mfg. No.	Size	Price /Each
AB953	39366	4 oz.	15.20

LOCTITE® FIXMASTER® UNDERWATER REPAIR EPOXY™

- Two-component, room temperature curing epoxy adhesive used for high strength, permanent bonding of metals, ceramics, concrete, wood and most plastics
- Can withstand temperatures of up to 150°C (300°F)
- Works on both wet and dry surfaces and sets up and cures underwater
- Putty like material is ideal for plumbing, irrigation and marine applications because it is unaffected by chlorinated or salt water
- Typical applications include plugging and filling gaps, leaks and holes in pipes, fitting tanks, valves and pumps
- Accepted for use in Canadian food processing facilities



LOCTITE

Model No.	Mfg. No.	Size	Price /Each
AE628	82093	4 oz.	19.40



ABS PREMIUM CEMENT

- Medium-bodied yellow coloured cement for ABS pipe and fittings up to 6" diameter
- For all types and grades of ABS pipe and fittings for DWV
- For all non-pressure applications
- Recommended application temperature: 40°F to 100°F
- Meets ASTM D-2235
- CSA approved

Oatey



Model No.	Description	Size	Price /Each
AB417	ABS Premium Cement Yellow	473 ml	6.82
AB418	ABS Premium Cement Yellow	946 ml	11.30

ABS STANDARD CEMENT

- Medium-bodied yellow coloured cement for use on ABS pipe and fittings up to 6" diameter
- For all non-pressure applications
- For all types and grades of ABS pipe and fittings for DWV
- Meets ASTM D-2235
- CSA approved

Oatey



Model No.	Description	Size	Price /Each
AB419	ABS Standard Cement Yellow	473 ml	6.47
AB420	ABS Standard Cement Yellow	946 ml	10.80

PVC HEAVY-DUTY GREY CEMENT

- Heavy-bodied grey coloured cement for use on PVC pipe and fittings up to 12" diameter for Sch. 40 and Sch. 80
- Thick formula fills gaps in large diameter pipe and fittings
- Recommended for all grades and types of PVC pipe and fittings, potable water, pressure pipe, gas, conduit and DWV
- Recommended application temperature 40°F to 100°F
- Meets ASTM D-2564
- CSA approved

Oatey



Model No.	Description	Size	Price /Each
AB423	PVC Heavy-Duty Grey	473 ml	11.10
AB424	PVC Heavy-Duty Grey	946 ml	18.80

PVC MEDIUM-DUTY GREY CEMENT

- Medium-bodied grey coloured cement for use on PVC pipe and fittings up to 6" diameter for Sch. 40 and Sch. 80
- Recommended for all grades and types of PVC pipe and fittings, potable water, pressure pipe, gas, conduit and DWV
- Recommended application temperature: 40°F to 100°F
- Meets ASTM D-2564
- CSA approved

Oatey



Model No.	Description	Size	Price /Each
AB421	PVC Medium Grey	473 ml	8.24
AB422	PVC Medium Grey	946 ml	15.10

PLUMBER'S PUTTY

- Stainless fixture setting compound for setting frames, faucets, strainer baskets, etc.
- Stays flexible and will not crack or shrink
- Soft pliable material is easy to work with
- Not for use on marble or plastic
- Meets Military Spec. TT-P-1536A

Oatey



Model No.	Description	Size	Price /Each
AB436	Putty – Plastic Container	14 oz.	2.14

CLEAR PRIMER

- A clear aggressive primer for use on PVC and CPVC pipe and fittings
- All schedules and all diameters
- Removes all surface dirt, grease and grime as well as softens pipe in preparation for solvent cement
- Meets ASTM F-656

Oatey



Model No.	Description	Size	Price /Each
AB434	Clear Primer – NSF Listed	473 ml	8.40
AB435	Clear Primer – NSF Listed	946 ml	14.50

PLASTIC WOOD® WOOD FILLERS

- Fills small holes and cracks in wood and hardboard
- Waterproof, takes nails and screws
- Can be stained or painted
- Fast drying

LEPAGE



Model No.	Size	Price /Each
AC180	500 ml	18.40
AC181	946 ml	33.90

See pages 1052 - 1053 for
Spatulas and Scrapers



FASTSTEEL®



- Moulds like clay, hardens like steel
- Repair ferrous and aluminum metals
- Rebuild engine parts, fill cracks and seal leaks
- Form nuts and bolts, repair stripped threads
- Repair metal tools, equipment, pipes, appliances and auto bodies
- Will not rust or shrink



Model No.	Size	Price /Each
AA261	114 g	12.56

AQUAMEND®



- Repairs to damp wet areas are done quickly and easily
- Rebuild holes in fibreglass, metal and wooden boat decks and hulls
- Repair leaking gaskets, water tanks, spas, hot tubs, pools, etc.
- Excellent adhesion to PVC, will not yellow when exposed to UV and cures to fibreglass white colour



Model No.	Size	Price /Each
AA266	114 g	12.56

INSTACRETE™



- Seal tie-rod holes
- Ideal for anchoring
- Repair of chipped concrete floors, curbing and steps
- Instant concrete repair
- Safe and solvent free
- Cures to a concrete colour
- Repair and rebuild decorative concrete trim, mouldings, statues, birdbaths, and other concrete lawn ornaments



Model No.	Size	Price /Each
AA268	114 g	12.56

REPAIRITQUICK®



- Repair loose or cracked wall and floor tiles
- Patch chipped concrete, bricks and masonry
- Electrical use in place of tape or plastic connector
- Fabricate small parts and mend holes
- Attach fixtures, machines, tags and signs
- 1001 household and industrial purposes



Model No.	Size	Price /Each
AA267	114 g	12.56

QUICKCOPPER®



- Repairs copper, brass, bronze and other non-ferrous metals
- Repair plumbing leaks in 15 minutes
- Bonds to damp and slow leaking surfaces
- Seals leaks in pipes, elbows, joints, sleeves, traps and drains



Model No.	Size	Price /Each
AA264	114 g	12.56

QUICK TITANIUM®



- Hand kneadable, for high temperature applications
- Consistency provides a "no mess" gap filling application without the use of tools
- No solvents
- Low odour
- Larger pot life
- Service Temperature -40°F to 500°F



Model No.	Size	Price /Each
AB482	114 g	13.89

QUICKWOOD®



- Fill holes, scratches, gouges, cracks, dry rot and knot holes
- Repair furniture, moulding and frames
- Reshape woodcarvings, remould wood knobs and handles
- Can be sanded, sawed, painted or stained
- Interior and exterior applications



Model No.	Size	Price /Each
AA265	57 g	12.56

QUICKPLASTIK®



- Ideal for repairs to automotive parts, plastic trim and appliances
- Seals leaks and bonds to major types of plastic approved for plumbing pipe
- Excellent for plastic outdoor furniture



Model No.	Size	Price /Each
AA263	114 g	12.56

QUICKALUMINUM®



- Many industrial and home maintenance applications: storm doors, aluminum tanks, aluminum boats, refrigeration units, recreational vehicles, aluminum Tubing and aluminum castings



Model No.	Size	Price /Each
AA262	114 g	12.56

ULTRA SEAL LOW EXPANDING STRAW FOAM

- A one component polymeric insulating foam/sealant that cures to a rigid seal which will allow for normal movement between building components
- Fills and seals gaps, cracks and holes within most types of construction materials to eliminate drafts
- Ideal for sealing around wall outlets, sill plates, foundation walls, behind baseboards, windows and doors
- Colour: White



Model No.	Size	Price /Each
AC612	12 oz.	7.41
AC613	24 oz.	17.26

ULTRA SEAL PF-100 GUN FOAM

- Quality moisture-curing polyurethane foam that seals, insulates, sound-deadens and bonds many common building materials together
- Fills gaps in new and retrofit construction such as around windows, doors and wall corners which are difficult to draft stop and insulate
- Seals out radon, drafts, gases, odours, water, dust, sound and pests
- AC608 professional dispensing gun

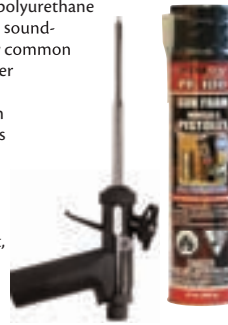

Model No.	Size	Colour	Price /Each
AC609	24 oz.	White	17.89
AC610	32 oz.	White	23.19
AC611	31 oz.	Black	20.42
AC608	Gun		207.88

FLEXTEC™ ADHESIVE & SEALANT

- Used for bonding and sealing dissimilar substrates
- High viscosity, sag resistant one component adhesive/sealant based on silane
- Modified polymer, which cures to an elastic product
- Free of solvents, isocyanates and silicones

LOCTITE

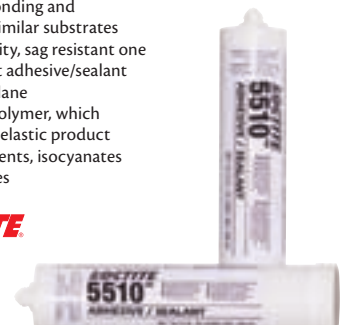

Model No.	Mfg. No.	Size	Colour	Price /Each
AD124	1562044	300 ml	Grey	13.80
AD125	1562042	300 ml	White	13.80
AD123	1560557	300 ml	Black	13.80
AF071	1562040	300 ml	Clear	14.70

CHEMICALS

CAULKING GUNS

STANDARD RATCHET TYPE

This improved caulking gun is recommended for medium and light consistency caulks, sealants and adhesives.

Its sturdy steel construction will ensure long lasting use.



Model No.	Size	Price/Each
TX604	300 ml	6.79

E-Z THRUST® HEX-ROD PARALLEL FRAME

Uniquely designed for professionals to develop a powerful thrust ratio, making extension of stiff caulks and sealants easy and comfortable. The extra long trigger and pivot above the post on rod delivers

3 times more thrust power than comparable guns. Other features include E-Z Thrust® mechanism, seal-puncture tool and spout cutter with ladder hook.



Model No.	Size	Price/Each
TZ936	300 ml	13.60

INDUSTRIAL ZINC - CHROMATE PLATED

This Super Hex Smooth Rod caulker is uniquely designed for professionals to develop a powerful thrust ratio, making the extrusion of stiff caulks and sealants easy and comfortable. Extra-long trigger and pivot above the piston rod delivers 3 times more thrust power than comparable guns. Other features include built-in spout cutter, seal-puncture tool, convenient D-ring and wrist strap.



Model No.	Size	Price/Each
TZ939	300 ml	24.00

WEXFORD & CHILTON

Compact size skeleton guns that fit in your tool box. Designed for comfortable operation over long periods of time. Smooth hexagonal drive rod and precision catch-plate provide effortless action.

Finished with a corrosion-resistant orange epoxy powder coat. Barrel rotates 360° (model AC132).



Model No.	Description	Size	Price/Each
AC132	Chilton	300 ml	45.00

SUPERIOR PROFESSIONAL QUALITY

Ratchet type caulking guns are recommended for extruding all grades of caulks, sealants and adhesives from light to heavy consistencies. Equipped with built-in spout cutter, seal-puncture tool and ladder hook.



Model No.	Size	Price/Each
TX606	300 ml	12.90
TX607	850 ml	25.50

SUPER INDUSTRIAL GRADE

This chrome plated caulker is designed for the professionals who prefer ratchet guns. Will outlast, outperform all other ratchet guns, and is engineered to withstand heavy use. Equipped with ladder hook, built-in spout cutter, seal-puncture tool and convenient D-ring and wrist strap.



Model No.	Size	Price/Each
TX610	300 ml	30.70

SUPER RATCHET TYPE

Professional quality Drip-Free Spring Clip Drive™ ratchet type caulking gun is recommended for extruding all grades of caulks, sealants and adhesives from light to heavy consistency. Also equipped with built-in spout cutter and seal-puncture tool.

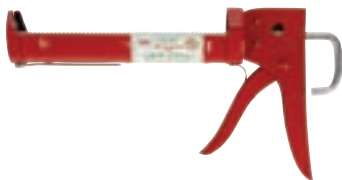

Model No.	Size	Price/Each
TZ938	300 ml	15.60

DRIP-FREE E-Z THRUST® HEX ROD PARALLEL FRAME

The patented Adjust-A-Stroke™ mechanism allows for easier or faster extrusion of heavy or light viscosity materials in warm or cold weather at the turn of a knob. In the E-Z position, you will develop a 10:1 thrust ratio. The Dripless on Demand™ feature allows you to instantly stop the caulk flow by quickly and fully releasing the trigger. Other features include built-in spout cutter, seal puncture tool, ladder hook, Drip-Free Spring Clip™, E-Z load open front cap and cartridge retainer spring.



Model No.	Size	Price/Each
TZ937	300 ml	19.20

CAULKING GUNS

- Compact size to fit in a tool box
- Skeleton design
- Comfortable operation
- Smooth hexagonal drive rod

Model No.	Size	Price/Each
TYK650	300 ml	7.85



AIR CAULKING GUNS

Designed to apply low and medium viscosity materials. Lightweight, high-impact, non-corrosive Valox™ construction. 3 foot hose with 1/4" NPT fitting. 70 PSI max.

STANDARD CARTRIDGE GUN

Uses standard 10.3-oz. cartridges.
Model No. WJ072
Mfg. No. PG100
Price/Each \$78.10



MULTI CARTRIDGE GUN

Uses both 10.3 and 30-oz. cartridges.
Model No. WJ073
Mfg. No. PG151
Price/Each \$141.00



Caulk Master®

PREMIUM 100% RTV SILICONE SEALANT

- Excellent adhesion to non-porous materials
- Provides a watertight seal
- Highly, permanently flexible
- Will not crack, crumble or shrink
- Resists moisture and mildew
- Interior/exterior use
- Size: 10 oz.



Model No.	Colour	Price /Each
AD892	Clear	8.91
AD893	White	8.91
AD894	Aluminum	8.91
AD895	Black	8.91

SUPERFLEX™ BLUE RTV SILICONE ADHESIVE SEALANT

- Cures to a tough, flexible rubber
- "Formed in Place" gaskets resist shrinking, cracking and migrating
- Fills gaps to 0.25"
- Coats pre-cut gaskets
- Low volatility
- Tack free in 30 min 24 hrs., full strength
- Temperature range -65°F to 500°F (-54°C to 260°C) intermittent
- Colour: Blue



LOCTITE

Model No.	Mfg. No.	Size	Price /Each
AC198	30560	80 ml tube	7.34
AC199	30533	300 ml cartridge	14.70

SUPERFLEX™ SILICONE ADHESIVE SEALANT

- General purpose, one part silicone adhesive, cures at room temperature to form a tough rubber seal
- Will not slump in overhead or vertical applications
- Withstands extreme temperature cycling, U.V. light and ozone
- Cannot be painted
- Tack free in 30 min. 24 hrs., full strength
- Temperature range -65°F to 450°F (-54°C to 232°C) intermittent
- Accepted for use in Canadian food processing facilities



LOCTITE

Model No.	Mfg. No.	Size	Colour	Price /Each
AC157	59330	80 ml tube	Black	7.34
AC158	59375	300 ml cartr.	Black	15.00
AC196	59530	80 ml tube	Clear	7.48
AC197	59575	300 ml cartr.	Clear	14.40
AC121	59430	80 ml tube	White	7.48
AC113	59475	300 ml cartr.	White	15.00

3006™ ALL PURPOSE ADHESIVE CAULK

- High quality acrylic latex formulation with silicone additives
- Cured caulk resists rust and mildew
- Applies a smooth, professional bead without gaps or bubbles
- Maintains excellent flexibility and elasticity
- Excellent colour retention
- Can be painted or stained after curing
- Interior/exterior use
- Exceeds ASTM Spec. C-834
- Size: 10 oz.



Model No.	Colour	Price /Each
AD884	White	5.47

SUPERFLEX™ RED HIGH TEMP RTV SILICONE

- Resists aging, weather and thermal cycling without shrinking, cracking or hardening
- Fills gaps to .25"
- Tack free in 30 min. 24 hrs., full strength
- Resist temperatures to 600°F (315°C) intermittent
- Colour: Red
- Accepted for use in Canadian food processing facilities



LOCTITE

Model No.	Mfg. No.	Size	Price /Each
AC166	59630	80 ml tube	9.23
AC167	59675	300 ml cartridge	16.00

598™ BLACK RTV SILICONE GASKET MAKER

- Adheres well to oily surfaces
- Low odour and volatility
- Fills gaps to 0.25"
- Forms tough, flexible gaskets directly on the flange
- Resistant to most chemicals and solvents
- Non-corrosive
- Tack free in 30 min. 24 hrs., full strength
- Temperature range: -75°F to 625°F (-59°C to 329°C) intermittent
- Colour: Black
- Accepted for use in Canadian food processing facilities



LOCTITE

Model No.	Mfg. No.	Size	Price /Each
AA488	59830	70 ml tube	13.20
AC195	59875	300 ml cartridge	28.30

CONTRACTOR RTV SILICONE SEALANT

- Made with 100% silicone
- Flexible watertight seal
- Minimal shrinking
- Interior/exterior use
- Size: 10 oz.



Model No.	Colour	Price /Each
AD890	Clear	6.98
AD891	White	6.98

PAINTER'S PREFERRED™ CAULK

- High quality acrylic latex formulation
- Cured caulk resists rust and mildew
- Applies a smooth, professional bead without gaps or air bubbles
- Can be painted when thoroughly dry
- Meets performance requirements of ASTM C-834 for extension recovery and adhesion
- Colour: White



Model No.	Size	Price /Each
AD882	10 oz.	3.69

GET CLEAN

Industrial handsoap with scrubbing particles for stubborn grease and grime

TRY SOME TODAY!

Model JG223
See page 327





587™ BLUE RTV SILICONE GASKET MAKER

- Adheres well to oily surfaces
- Low odour and volatility
- Fills gaps to 0.25"
- Forms tough, flexible gaskets directly on the flange
- Resistant to most chemicals and solvents
- Non-corrosive
- Tack free in 30 min. 24 hrs., full strength
- Withstands temperatures to 500°F (260°C) intermittent
- Colour: Blue
- Accepted for use in Canadian food processing facilities



LOCTITE

Model No.	Mfg. No.	Size	Price /Each
AA489	58730	70 ml tube	12.80
AC201	58775	300 ml cartridge	28.30

518™ FLANGE SEALANT

- Forms a flexible, solvent-resistant seal that will not tear or decay
- For flexible metal including aluminum
- 0.010" unprimed gap fill, 0.020" primed gap fill
- -65°F to 300°F
- Cures 4 to 24 hours (unprimed), 30 mins. to 4 hrs. (primed)
- Colour: Red
- Accepted for use in Canadian food processing facilities



LOCTITE

Model No.	Mfg. No.	Size	Price /Each
AA490	51831	50 ml	24.00
AB367	51845	300 ml	85.80

FLANGE SEALANT 515™

- Flexible gaskets for rigid machined flanges
- Flexes with flanges that move in service
- For flexible applications
- 0.010" unprimed gap fill, 0.020" primed gap fill
- -65°F to 300°F
- Cures 1 to 12 hours (unprimed), 15 mins. to 2 hrs. (primed)
- Colour: Purple
- Accepted for use in Canadian food processing facilities



LOCTITE

Model No.	Mfg. No.	Size	Price /Each
AC088	51531	50 ml	24.00
AC089	51580	300 ml	85.80

QUICKSTIX™ 548™ GASKET ELIMINATOR®

- Formulated with excellent oil resistance for rigid flange sealing
- Ideal for on-the-spot repairs
- For use on a variety of metal surfaces, including aluminum
- Seals up to 300°F (149°C)
- Fills gaps to 0.010"
- Accepted for use in Canadian food processing facilities



LOCTITE

Model No.	Mfg. No.	Size	Price /Each
AB938	39152	18 g	25.80

565™ PST® CONTROLLED STRENGTH THREAD SEALANT

- General purpose instant sealant for tapered and straight/tapered fittings
- Controlled strength for ease of disassembly
- Withstands temperatures to 300°F
- Colour: White
- Accepted for use in Canadian food processing facilities



LOCTITE

Model No.	Mfg. No.	Size	Price /Each
AA540	56531	50 ml	21.30
AA541	56541	250 ml	73.20

567™ PST® HIGH TEMPERATURE THREAD SEALANT

- Locks and seals tapered pipe threads and fittings, including high pressure applications
- Disassembles with hand tools
- Withstands temperatures to 400°F
- Colour: White
- Accepted for use in Canadian food processing facilities



LOCTITE

Model No.	Mfg. No.	Size	Price /Each
AA543	56747	50 ml	22.20
AA431	56765	250 ml	81.50

592™ PST® SLOW CURE THREAD SEALANT

- Locks and seals threaded fittings
- Parts may be repositioned up to 24 hours after application
- Withstands temperatures to 400°F
- Colour: White
- Accepted for use in Canadian food processing facilities



LOCTITE

Model No.	Mfg. No.	Size	Price /Each
AC100	59231	50 ml	22.40
AB349	59241	250 ml	76.80

PST® 561™ THREAD SEALANT STICK

- Immediate low pressure sealing to 100 PSI
- Protects threads from rust and corrosion
- Exceptional fluid compatibility and chemical resistance
- Will not contaminate or clog lines
- Eases disassembly
- Seals all types of metal tapered threads and fittings to NPT specs
- For chemical processing, waste water treatment, and automotive
- Temperature resistance 300°F (150°C)
- Colour: White
- No mess, portable stick
- Accepted for use in Canadian food processing facilities

LOCTITE



Model No.	Mfg. No.	Size	Price /Each
AB652	37127	19 g	17.50

545™ THREAD SEALANT HYDRAULIC/ PNEUMATIC SEALANT

- Liquid sealant for locking and sealing high pressure, fluid power systems with tapered fittings
- No fillers and will not foul valves or fluid filtering systems
- For locking and sealing hydraulic and pneumatic fittings, servomechanisms, and fine-filtration systems
- Specially formulated to offer lubricity for easy assembly
- Withstands temperatures to 300°F
- Colour: Purple
- Accepted for use in Canadian food processing facilities



LOCTITE

Model No.	Mfg. No.	Size	Price /Each
AC357	32429	10 ml	16.00
AA542	54531	50 ml	47.60

609™ GENERAL PURPOSE RETAINING COMPOUND

- Low viscosity retaining compound that bonds rigid metal assemblies
- Ideal for gap distances up to 0.005"
- Fixtures in 10 minutes, full in 24 hrs.
- Provides a shear strength of 3000 PSI after 24 hours
- Withstands temperatures to 300°F
- Locks keys and splines - eliminates backlash in worn assemblies
- Locks bushings and sleeves in housings and on shafts
- Augments press fits
- Colour: Green
- Accepted for use in Canadian food processing facilities



LOCTITE

Model No.	Mfg. No.	Size	Price /Each
AA538	60921	10 ml	15.20
AA539	60931	50 ml	48.50

620™ HIGH TEMPERATURE RETAINING COMPOUND

- High temperature, high viscosity retaining compound
- Ideal for gap distances up to 0.015"
- Fixtures in 30 minutes, full in 24 hrs.
- Provides a shear strength of 3800 PSI on steel
- Withstands temperatures to 450°F
- Seals against leakage
- For retaining pins and sealing threads in steam platens and retaining valve seats
- Colour: Green
- Accepted for use in Canadian food processing facilities



LOCTITE

Model No.	Mfg. No.	Size	Price /Each
AA457	62015	10 ml	16.30
AC102	62040	50 ml	49.40

641™ CONTROLLED STRENGTH RETAINING COMPOUND

- For cylindrical parts that require disassembly
- Ideal for gap distances up to 0.008"
- Fixtures in 20 minutes, full in 24 hrs.
- Provides a shear strength of 1700 PSI
- Withstands temperatures to 300°F
- Colour: Yellow
- Accepted for use in Canadian food processing facilities



LOCTITE

Model No.	Mfg. No.	Size	Price /Each
AC355	28802	10 ml	16.30
AA546	21458	50 ml	49.40

660™ QUICK METAL® PRESS FIT REPAIR RETAINING COMPOUND

- Creamy, non-running adhesive/sealant
- Repairs worn machine parts
- Restores correct fit to mating assemblies
- Ideal for gap distances up to 0.020"
- For worn shafts and housings, bearing spinouts, keyways, and splines
- Fixtures in 20 minutes, full in 24 hrs.
- Shear strength of 3300 PSI on steel
- Withstands temperatures to 300°F
- Colour: Silver
- Accepted for use in Canadian food processing facilities



LOCTITE

Model No.	Mfg. No.	Size	Price /Each
AC103	66010	6 ml	12.90
AC104	66040	50 ml	50.90

QUICKSTIX™ 668™ RETAINING COMPOUND

- Used for bonding non-threaded, cylindrical metal assemblies with gaps up to 0.005" (0.13 mm)
- Prevents fretting and corrosion of metal assemblies up to 400°F (204°C)
- Accepted for use in Canadian food processing facilities



LOCTITE

Model No.	Mfg. No.	Size	Price /Each
AB937	39148	19 g	41.20

680™ HIGH STRENGTH/HIGH VISCOSITY RETAINING COMPOUNDS

- Ideal curing adhesive for joining fitted cylindrical parts
- Fixtures in 10 minutes and provides a shear strength of 4000 psi
- Capable of filling diametral gaps up to 0.015 inches
- Gives the best resistance to dynamic, axial and radial loads
- Full Cure Time: 24 hrs.
- Colour: Green



LOCTITE

Model No.	Mfg. No.	Size	Price /Each
AF074	1835205	10 ml	16.30

648™ HIGH STRENGTH/ RAPID CURE RETAINING COMPOUNDS

- Ideal for clearance and interface fit parts
- Excellent performance for dynamic, axial and radial loads
- Works through contaminants such as oils and corrosion protection fluids
- Cures on metals without needing an applicator
- Application Time: 3 minutes
- Full Cure Time: 24 hrs.
- Shear Strength: 3900 psi
- Ideal for gap distance up to 0.006"



LOCTITE

Model No.	Mfg. No.	Size	Colour	Price /Each
AF076	1835922	10 ml	Green	17.70
AF077	1835920	50 ml	Green	56.80

TEFLON® THREAD SEALANT TAPE

- For sealing threaded pipe joints
- Easy disassembly even after years of service
- Works under pressures up to 2000 PSI and temperatures from -450°F to 550°F
- 144 rolls per case



Markal
High Performance Industrial Markers

Model No.	Size"	Price /Each
PA684	1/2 x 520	1.05
PA685	3/4 x 520	3.03

THREADLOCKER STICKS

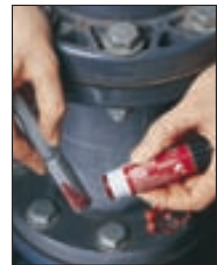

LOCTITE

Model No.	Mfg. No.	Size	Price /Each
248™ MEDIUM STRENGTH - BLUE			
AB649	37087	19 gr.	36.70
AB648	37684	9 gr.	17.40
268™ HIGH STRENGTH - RED			
AB651	37686	19 gr.	36.70
AB650	37685	9 gr.	18.40

290™ WICKING GRADE THREADLOCKER

MEDIUM STRENGTH

- For pre-assembled bolts up to 1/2" (12 mm)
- Penetrates threads by capillary action
- Secures set screws and other assemblies after settings are completed
- Localized heating and hand tools are needed for disassembly
- For preassembled fasteners, instrumentation screws, electrical connectors and carburetors
- Withstands temperatures to 300°F
- Torque: 85/250 in.-lbs.
- Fixtures in 6 minutes, full in 24 hrs.
- Colour: Green



LOCTITE

Model No.	Mfg. No.	Size	Price /Each
AA454	29021	10 ml	14.00
AA455	29031	50 ml	48.50
AA024	29041	250 ml	167.00

262™ HIGH STRENGTH THREADLOCKER

- For fasteners up to 3/4" (20 mm) dia.
- High lubrication for easy assembly
- Excellent for preventing rust and corrosion in extreme chemical/ environmental conditions
- For all fasteners that must withstand heavy shock, vibration, or extreme environmental or chemical conditions
- Withstands temperatures to 300°F
- Torque: 190/275 in.-lbs.
- Fixtures in 5 minutes, full in 24 hrs.
- Colour: Red



LOCTITE

Model No.	Mfg. No.	Size	Price /Each
AA452	26221	10 ml	15.20
AA453	26231	50 ml	49.40
AA741	26241	250 ml	170.00

272™ HIGH TEMP./HIGH STRENGTH THREADLOCKER

- Recommended for bolts up to 1 1/2" (36 mm) in diameter
- Provides a fast cure on most surfaces including "as received" fasteners
- Heat and hand tools are required for disassembly
- Withstands temperatures to 450°F
- Torque: 200/220 in.-lbs.
- Fixtures in 30 minutes, full in 24 hrs.
- Colour: Red



LOCTITE

Model No.	Mfg. No.	Size	Price /Each
AA552	27240	50 ml	48.50
AC324	27270	250 ml	167.00

263™ HIGH STRENGTH/ RAPID CURE THREADLOCKER

- Designed for the permanent locking and sealing of threaded fasteners
- Ideal for heavy-duty applications such as studs into motor housings, nuts onto studs in pump housings and other fasteners where high strength is required
- Provides robust curing performance
- Works on active metals such as brass, copper and passive substrates such as stainless steel and plated surfaces
- Offers high temperature performance and oil tolerance
- Torque: 325/320 in.-lbs.
- Withstands temperature from -65°F to 360°F
- Fixture in 4 min., full 24 hrs.
- Colour: Red
- Acceptable for use in Canadian food processing establishments



LOCTITE

Model No.	Mfg. No.	Size ml	Price /Each
AD289	1330583	10	15.20
AD290	1330585	50	48.50
AD291	1330335	250	167.00

242® MEDIUM STRENGTH THREADLOCKER

- Removable threadlocker for fasteners between 1/4" and 3/4" (6 to 20 mm) diameters
- Controlled lubricity for accurate clamp loads
- Parts can be separated using hand tools
- For machine tools, presses, pumps, compressors, mounting bolts and gearboxes
- Withstands temperatures to 300°F
- Torque: 115/53 in.-lbs.
- Fixtures in 10 minutes, full in 24 hrs
- Colour: Blue



LOCTITE

Model No.	Mfg. No.	Size	Price /Each
AA450	24221	10 ml	15.20
AA451	24231	50 ml	49.40
AA652	24241	250 ml	170.00

243™ OIL TOLERANT/ MEDIUM STRENGTH THREADLOCKER

- For fasteners between 1/4" and 3/4" (6 to 20 mm) diameters
- Medium strength threadlocker with improved oil tolerance
- Parts can be separated using hand tools
- For machine tools, presses, pumps, compressors, mounting bolts and gearboxes
- Withstands temperatures to 360°F
- Torque: 180/62 in.-lbs.
- Fixtures in 5 minutes, full in 24 hrs
- Colour: Blue



LOCTITE

Model No.	Mfg. No.	Size	Price /Each
AA188	1329837	10 ml	15.20
AA555	1329467	50 ml	48.50
AC322	1329505	250 ml	167.00

246™ HIGH TEMP./ MEDIUM STRENGTH THREADLOCKER

- Suitable for fasteners between 1/4" and 3/4" (6 to 20 mm) diameters
- Resists oil and mild surface contamination at continuous temperatures to 450°F
- Torque: 170/48 in.-lbs.
- Fixtures in 20 minutes, full in 24 hrs.
- Colour: Blue



LOCTITE

Model No.	Mfg. No.	Size	Price /Each
AC353	29513	10 ml	18.00
AC330	29514	50 ml	56.60
AC321	29515	250 ml	201.00

222MS™ LOW STRENGTH THREADLOCKER

- Ideal for fastener diameters of 1/4" (6 mm) and smaller
- Controlled lubricity for accurate clamp loads
- Parts can be separated using hand tools
- For set screws, adjustment screws, calibration screws, meters and gauges
- Withstands temperatures to 300°F
- Torque: 62/27 in.-lbs.
- Fixtures in 20 minutes, full in 24 hrs
- Colour: Purple



LOCTITE

Model No.	Mfg. No.	Size	Price /Each
AA014	22221	10 ml	15.20
AA015	22231	50 ml	48.50
AA513	22241	250 ml	167.00

INSULATING & SEALING WRAP

- Non-sticky, self fusing, multipurpose wrap
- Withstand extreme conditions: -65°F to 500°F
- Tensile strength up to 700 psi and dielectric strength up to 400 VPM
- UV, saltwater, fuel and acid resistant



LOCTITE

Model No.	Mfg. No.	Size	Colour	Price /Each
AD155	1212164	1" x 10' Roll	Red	12.60
AF072	1540599	1" x 10' Roll	Black	12.60
AF073	1496756	2" x 36' Roll	Black	54.50

POWER GRAB® INDUSTRIAL CONSTRUCTION ADHESIVE

- Heavy-duty, high strength, grabs instantly and is repositionable for 15 minutes
- Non-solvent, low-odour, latex formula cleans up with soap and water
- Low emissions/VOC content and meets Greenguard® certification
- Colour: Clear



LOCTITE

Model No.	Mfg. No.	Size	Price /Each
AF078	1804373	300 ml Cartridge	8.19

NUFLEX® 458 SUB-FLOOR CONSTRUCTION ADHESIVE

- Ideal for particleboard, OSB and engineered lumber as well as wet, frozen and treated lumber
- Provides superior adhesive strength and remains permanently flexible
- Fills gaps and irregularities between materials and provides a more solid backup surface
- Reduces the amount of nailing, increases floor rigidity and helps eliminate squeaky floors
- Exceeds AFG-01 specifications
- Freeze-thaw stable
- Superior extreme temperature adhesive; works extremely well in colder temperatures and offers excellent water-resistance



Model No.	Mfg. No.	Size	Price /Each
AE622	45880	828 ml	8.47

CARPENTER'S® WOOD GLUE

- Made for furniture repair and general indoor household projects
- Best for soft and hardwoods, particle board and porous materials
- Cleans up with soap and water when wet, and scrape and sand when glue is dry
- Open time: 10-15 minutes before clamping
- Clamp time: 12 hours
- Light colour for natural and light stained woods
- Pourable
- Colour when dry: Yellow



Model No.	Mfg. No.	Size	Price /Each
AE610	60615TR	118 mL	2.92
AE611	60613TR	236 mL	4.45
AE612	60617TR	473 mL	7.49
AE613	6155060618	950 mL	12.70
AE614	6155060619	3.8 L	36.50

TEN BOND CONTACT CEMENT

- Brush-able, neutral-colored contact adhesive for bonding many decorative laminates, aluminum, steel, plywood, panels, wood and wood veneer, masonry, rubber, canvas and other porous and non-porous materials
- Air drying adhesive which bonds immediately and permanently upon application of contact pressure
- No clamping or fixturing required

3M



Model No.	Mfg. No.	Size	Price /Each
AMC295	10-1L	1 L	38.90
AMC294	10-1GAL	1 gal.	112.00

NUFLEX® 480 POLYURETHANE CONSTRUCTION ADHESIVE

- Excellent adhesion strength
- 100% polyurethane based, VOC compliant adhesive
- Can be used for interior or exterior projects and is three times as strong as conventional solvent based construction adhesives
- Ideal for wood, hardwood flooring, concrete, stone, marble, slate, masonry, brick, foam insulation, carpets, metal, lead, cement-based products, ceramics, fiberglass, drywall and mirrors
- Contributes to LEED credit
- Low-odor
- Adheres to dry, wet and frozen lumber
- Waterproof, paintable and cures even in cold temperatures
- AFG-01 approved



Model No.	Mfg. No.	Size	Price /Each
AE623	48000	296 ml	9.74
AE624	48080	828 ml	22.10

PROBOND® MAX WOOD GLUE

- Made for furniture repair and general indoor and outdoor household projects
- Best on wood
- Contains real wood fibers for superior staining, painting, and sanding
- Open time: 10-15 minutes before clamping
- Clamp time: 12 hours
- Easy to clean-up with water
- Pourable and waterproof
- Colour when dry: Beige



Model No.	Mfg. No.	Size	Price /Each
AE615	69220	118 mL	4.27
AE616	69221	236 mL	7.16
AE617	69222	473 mL	10.50
AE618	69224	3.8 L	46.60

THREAD SEALANT WITH PTFE

- Added lubricate of PTFE for metal pipes
- Will not shred like Teflon™ tape
- Allows easy disassembly
- Resists common shop fluids
- 5000 psi pressure resistance
- Withstands temperatures to 300°F
- Colour: White
- Container Type: Brush Can



LOCTITE

Model No.	Mfg. No.	Size	Price /Each
AC144	1527514	473 ml	22.30

WHITE GLUE

- Washable no-run glue; easy to clean up
- Safe and non-toxic
- Pourable
- Recommended for wood, wood compositions, veneer, paper, cardboard, leather, fabric and cork
- Not recommended for joints that require gap filling, bonding non-porous substrates (i.e. plastic or metal)
- Colour: White



Model No.	Mfg. No.	Size	Price /Each
AE606	60307W8	120 ml	2.21
AE607	60310Q	225 ml	3.39
AE608	6155060331	950 ml	9.40
AE609	6155060341	3.8 L	29.60

ULTIMATE® POLYURETHANE GLUE

- The ultimate adhesive; adheres to anything with a permanent, strong, waterproof bond
- Indoor and outdoor
- Does not require any mixing
- Sandable and paintable
- Best on stone, metal, ceramic, wood, foam, glass, etc.
- Open time: 30 minutes before clamping
- Clamp time: 12 hours
- Clean up: mineral spirits or acetone when glue is wet; sanding and scraping when glue is dry
- Colour when dry: Yellow



Model No.	Mfg. No.	Size	Price /Each
AE619	6155069406	60 mL	7.00
AE620	69416	236 mL	15.20
AE621	69417	473 mL	26.90



Performance consideration	Adhesive Category								
	Cyanoacrylates	Epoxies	Hot Melts	Light Cure	Silicones	Elastomers	Urethanes	2-part Acrylics	2 step Acrylics
Benefits	Wide range of bonding applications	Wide range of formulations	Versatile, fast, large gap filling	Rapid cure/adhesion to plastics	Excellent temperature resistance	Flexible, paintable, bonder/sealant	Excellent toughness/flexibility	Good impact resistance/flexibility	Good impact resistance/ no-mix
Limitations	Low solvent resistance	Mixing required	Limited heat resistance	Light cure resistance	Low adhesion resistance	High temperature resistance	Sensitive to moisture	Mixing required	Primer required
Temperature resistance									
Typical for the category	-65°F to 180°F (-54°C to 82°C)	-65°F to 180°F (-54°C to 82°C)	-65°F to 250°F (-54°C to 121°C)	-65°F to 300°F (-54°C to 149°C)	-65°F to 400°F (-54°C to 204°C)	-65°F to 200°F (-54°C to 93°C)	-65°F to 250°F (-54°C to 121°C)	-65°F to 250°F (-54°C to 121°C)	-65°F to 300°F (-54°C to 149°C)
Environmental resistance									
Polar solvents (ex: water, ethylene glycol, isopropyl alcohol, acetone)	Poor (1)	Very Good	Good	Good	Good	Good	Good	Good	Good
Non-polar solvents (ex: motor oil, toluene, gasoline, ATF)	Good	Excellent	Good	Very Good	Poor to Fair	Poor	Good	Very Good	Very Good
Adhesion to substrates									
Metals	Very Good	Excellent	Good	Good	Good	Very Good	Good	Excellent	Excellent
Plastics (2)	Excellent	Fair	Very Good	Excellent	Fair	Good	Very Good	Excellent	Fair
Glass	Poor	Excellent	Good	Excellent	Very Good	Good	Good	Good	Excellent
Rubber	Very Good	Fair	Fair	Fair	Good	Poor	Good	Poor	Poor
Wood	Good	Very Good	Excellent	Poor	Fair	Very Good	Fair	Good	Good

Process consideration	Adhesive Category								
	Cyanoacrylates	Epoxies	Hot Melts	Light Cure	Silicones	Elastomers	Urethanes	2-part Acrylics	2 step Acrylics
Cure temperature	Room Temperature	Room Temperature	Room Temperature (3)	UV/Visible	Room Temperature	Room Temperature	Room Temperature	Room Temperature	Room Temperature
Fixture time									
Average	60 seconds	20 minutes	70 seconds	30 seconds	25 minutes	25 minutes	25 minutes	20 minutes	5 minutes
Full cure time	24 hours	12 to 24 hours	1 hour (or when cooled) (4)	30 to 60 seconds	1 to 7 days	1 to 7 days	24 hours	24 hours	24 hours

SUBSTRATE	GALVANIZED	STEEL, ALUMINUM, STAINLESS STEEL	POLYPROPYLENE, UHMW, HDPE, POLYETHYLENE, NYLON, ACETAL	ACRYLIC, POLYCARBONATE, STYRENE, PVC, ABS	FIBREGLASS, POLYESTER OR EPOXY	GLASS, CERAMIC	WOOD, LEATHER, CARDBOARD
GALVANIZED	H8600™	H8600™	U-05FL™	H8600™	H8600™	H8600™	E-20HP™
STEEL, ALUMINUM, STAINLESS STEEL	H8600™	H8000™, H3151™	U-05FL™	H8000™, U-05FL™	H8000™, H3151™, H3000™	E-20HP™	E-20HP™
POLYPROPYLENE, UHMW, HDPE, POLYETHYLENE, NYLON, ACETAL	U-05FL™	U-05FL™	U-05FL™	U-05FL™	U-05FL™	U-05FL™	Cyanoacrylates or Hot melt
ACRYLIC, POLYCARBONATE, STYRENE, PVC, ABS	H8600™	H8000™, U-05FL™	U-05FL™	H8000™, H3151™, H3000™	H8000™, H3000™	H8000™	Cyanoacrylates
FIBREGLASS, POLYESTER OR EPOXY	H8600	H8000™, H3151™, H3000™	U-05FL™	H8000™, H3000™	H8000™, H4800™, H3000™, E-20HP™	E-20HP™, E-30CL™, 330™ Depend®	E-20HP™
GLASS, CERAMIC	H8600™	E-20HP™	U-05FL™	H8000™	E-20HP™, E-30CL™, 330™ Depend®	E-30CL™, 330™ Depend®	E-20HP™
WOOD, LEATHER, CARDBOARD	E-20HP™	E-20HP™	Cyanoacrylates or Hot melt	Cyanoacrylates	E-20HP™	E-20HP™	E-20HP™

- (1) Cyanoacrylates have very good moisture resistance on plastics
- (2) Uncured liquid adhesives may cause stress cracking of certain thermoplastics, e.g., polycarbonate, acrylic and polysulfone.
- (3) Elevated temperatures are required to dispense liquid Hot Melt Adhesives.
- (4) Urethane Hot Melts require 24 hours for full cure.

PLEASE NOTE: This chart should not be used to specify products without specific testing. It is recommended that you conduct on-part testing to ensure product performance before specifying any adhesive.

INSTANT ADHESIVES (CYANOACRYLATES)

- Widest selection of high-performance, application-specific, instant adhesives
- Available in a variety of viscosities, cure speeds, gap-filling capabilities and substrate compatibilities
- Ultra-high performance Loctite Prism® family offers toughened formulations, low odor, low blooming and thermally resistant formulations

431™ SURFACE INSENSITIVE INSTANT ADHESIVE

- Medium viscosity, clear, gap filling, surface insensitive, one part, room temperature cure instant adhesive
- Designed for the assembly of difficult-to-bond materials which require uniform stress distribution
- Particularly suited for bonding a wide range of materials, including metals, plastics, and elastomers
- Typical use: Gap filling
- Gap fill: 0.008 IN
- Viscosity: 1 000 cP
- Shear strength: 2300 PSI
- Temperature Range: -65°F to 180°F (-54°C - 82°C)
- Cure speed: Fixture – 15 sec., full: 24 hrs.
- Colour: Clear



LOCTITE

Model No.	Mfg. No.	Size	Price /Each
AD406	41254	3 g Tube	7.67
AD407	41255	20 g Bottle	28.60
AD408	41256	1 lb. Bottle	344.00

435™ CLEAR SURFACE INSENSITIVE INSTANT ADHESIVE

- The first true clear, surface insensitive, elastomer-modified instant adhesive
- Low viscosity, clear, rubber toughened, one part, room temperature cure instant adhesive
- Designed for bonding metal, rubber and plastics
- Excellent peel, impact and shear strength on metals, plastics and rubbers
- Typical use: General purpose
- Gap fill: 0.006 IN
- Viscosity: 22 cP
- Shear strength: 2700 PSI
- Temperature range: -65°F to 240°F (-54°C to 115°C)
- Cure speed: fixture 30 sec., full 24 hrs.
- Colour: Clear

LOCTITE



Model No.	Mfg. No.	Size	Price /Each
AD414	40994	20 g Bottle	33.00
AD415	40995	1 lb. Bottle	388.00

3092™ TWO-PART INSTANT ADHESIVE

- Fast, two-part CA bonds gaps up to 0.200" (5 mm)
- Good for bonding plastics, rubbers, wood, paper and metals
- High precision dispensing tips
- Includes a 10 gram syringe with 3 mix nozzles



LOCTITE

Model No.	Mfg. No.	Size	Price /Each
AE630	1807961	10 g	25.40

410™ INSTANT ADHESIVE BLACK/TOUGHENED

- High viscosity, black, rubber toughened, one part, room temperature cure, gap filling instant adhesive
- Designed for bonding metal, rubber and selected plastics
- Excellent peel, impact and shear strength
- Typical use: Gap filling
- Gap fill: 0.008 IN
- Viscosity: 3500 cP
- Shear strength: 3200 PSI
- Temperature range: -65°F to 225°F (-54°C to 107°C)
- Cure speed: Fixture – 90 sec., full – 24 hrs.
- Colour: Black



LOCTITE

Model No.	Mfg. No.	Size	Price /Each
AD410	41004	3 g Tube	7.87
AD411	41045	20 g Bottle	34.70
AD412	41061	1 lb. Bottle	388.00

401™ GENERAL PURPOSE INSTANT ADHESIVE

- A general purpose adhesive for difficult-to-bond surfaces
- For bonding porous or absorbent materials, such as wood, paper, leather or fabric
- Ideal for gap distances up to 0.005"
- Fixtures in 15 seconds, full in 24 hrs.
- Provides a shear strength of 3200 PSI
- Withstands temperatures to 250°F
- Colour: Clear
- Improved formula



LOCTITE

Model No.	Mfg. No.	Size	Price /Each
AA544	40104	3 g Tube	7.09
AA545	40140	20 g Bottle	28.60
AD987	40161	1 lb. Bottle	353.00

454™ PRISM® INSTANT ADHESIVE GEL

- A general purpose, no-run clear gel
- Excellent for almost all surfaces
- Ideal for porous substrates and rough and acidic surfaces
- Ideal for gap distances up to 0.010"
- Fixtures in 15 seconds, full in 24 hrs.
- Provides a shear strength of 3200 PSI
- Withstands temperatures to 250°F
- Colour: Clear
- Improved formula



LOCTITE

Model No.	Mfg. No.	Size	Price /Each
AA548	45404	3 g Tube	6.89
AB343	45440	20 g Tube	37.00
AF079	45474	200 g Tube	202.00
AA549	45478	300 g Cartridge	260.00

495™ SUPER BONDER® INSTANT ADHESIVE

- A medium viscosity, high temperature product for all metals, and most plastics and rubbers
- Resists temperatures to 223°F continuous or up to 250°F intermittent
- Ideal for gap distances up to 0.004"
- Fixtures in 20 seconds, full in 24 hrs.
- Provides a shear strength of 2750 PSI
- Colour: Clear
- Improved formula



LOCTITE

Model No.	Mfg. No.	Size	Price /Each
AA456	49504	3 g Tube	5.23
AA487	49550	1 oz. Bottle	26.20
AB366	49561	1 lb. Bottle	270.00

380™ BLACK MAX® TOUGHENED

- Bonds metal, rubber, and plastic
- For use in difficult environments
- Ideal for gap distances up to 0.006"
- Fixtures in 90 seconds, full in 24 hrs.
- Provides a shear strength of 3750 PSI
- Withstands temperatures to 225°F
- Colour: Black



LOCTITE

Model No.	Mfg. No.	Size	Price /Each
AA493	38004	3 g Tube	7.26
AA494	38050	1 oz. Bottle	40.90
AF080	38061	1 lb. Bottle	370.00

QUICKTITE® INSTANT ADHESIVE GEL

- A general purpose instant adhesive
- Precision flow control applicator
- Designed to be clog-free



LOCTITE

Model No.	Mfg. No.	Size	Price /Each
AB950	39202	0.14 oz. bottle	8.04

CHEMICALS

404™ QUICK SET™ INDUSTRIAL ADHESIVE

- A general purpose adhesive for general maintenance and repair
- Excellent for rubber bonding
- Ideal for gap distances up to 0.005"
- Fixtures in 30 seconds, full in 24 hrs.
- Provides a shear strength of 3500 PSI
- Withstands temperatures to 180°F
- Colour: Clear



LOCTITE

Model No.	Mfg. No.	Size	Price /Each
AA550	46551	1/3 oz. bottle	30.40
AC325	46548	4 oz. bottle	213.00

403™ PRISM® INSTANT ADHESIVE

- Low-odour, low blooming, surface-insensitive
- Faster fixture speeds on plastics and metals
- Perfect for gap filling
- Cure speed: Fixture 50 sec, full 24 hrs.
- Viscosity: 1000 cP
- Temperature range: -65°F to 160°F (-54°C to 71°C)
- Shear strength: 2600 PSI
- Colour: Clear
- Improved formula



LOCTITE

Model No.	Mfg. No.	Size	Price /Each
AD429	40340	20 g Bottle	33.40
AD430	40361	1 lb. Bottle	439.00

414™ SUPER BONDER® INSTANT ADHESIVE

- General purpose cyanoacrylate plastic bonder
- Mil Spec: Mil-A-46050C Type II Class II
- Commercial Item Description A-A-3097: Type II Class II
- Typical use: Plastic bonder
- Gap Fill: 0.006 in.
- Viscosity: 11 cP
- Shear Strength: 3200 PSI
- Temperature Range: -65°F (-54°C) to 180°F (82°C)
- Cure Speed: Fixture - 20 secs; Full - 24 hrs.
- Colour: Clear



LOCTITE

Model No.	Mfg. No.	Size	Price /Each
AA654	41404	3 g Tube	5.90
AA655	41450	1 oz. Bottle	26.80
AA656	41461	1 lb. Bottle	270.00

LOCTITE® 7387 ACTIVATORS

- Designed to initiate the cure of Loctite toughened acrylic adhesives such as Loctite 315™, 383™ and 384™



LOCTITE

Model No.	Mfg. No.	Size	Price /Each
AD140	18861	1.75 oz.	19.90
MLN387	18862	32 oz.	122.00

7452™ TAK PAK ACCELERATOR

- Aggressive cleaning properties, promote the cure speed of all Loctite® Cyanoacrylate Adhesives
- < 30 second dry time
- 1 minute on-part life
- Colour: clear/amber
- Spray-cap bottle



LOCTITE

Model No.	Mfg. No.	Size	Price /Each
AC360	18580	1.75 fl. oz.	12.20
AE660	18575	1 qt. can	66.70
AF081	18567	1 gal. can	118.00

7387™ HEPTANE/ISOPROPYL ALCOHOL ACTIVATORS

- Used to initiate the cure of toughened acrylic adhesives
- Primer for Loctite 330™, 331™ and 332™



LOCTITE

Model No.	Mfg. No.	Size	Price /Each
AF099	21088	4.5 oz.	29.30

770™ PRIMER

- An adhesion promoter formulated for use with polyolefins and other low energy surfaces
- Use with Loctite® Cyanoacrylate Adhesives
- 30-second dry time
- 8-hour on-part life
- Colourless



LOCTITE

Model No.	Mfg. No.	Size	Price /Each
AA041	18396	1.75 fl. oz.	20.60
AD978	18397	16 fl. oz.	111.00

4090™ HYBRID STRUCTURAL INSTANT ADHESIVES

- Hybrid adhesive designed to incorporate the best features of cyanoacrylates and epoxy formulas
- Works on a variety of substrates and is suitable for structural applications
- Gap filling up to 0.2 inches
- Temperature resistance up to 300°F
- 1:1 mix ratio
- Colour: Slightly cloudy to light yellow
- Application Time: 5 minutes
- Full Cure Time: 24 hrs.



LOCTITE

Model No.	Mfg. No.	Size	Price /Each
AF101	1915601	50 ml	54.80

Ask us about volume prices!



In many cases you will benefit from quantity prices.

METAL BONDING STRUCTURAL ADHESIVES:

- Specially formulated to provide tough, long-lasting bonds to metal surfaces, such as steel galvanized steel, aluminum, sheet metal and stainless steel
- Capable of reducing or replacing the need for threaded fasteners, welds or rivets, resulting in a higher quality assembly

U-05FL™ HYSOL® URETHANE ADHESIVE

- Fast setting, highly flexible adhesive for metal bonding
- 5-minute working life
- High strength, flexible
- Chemistry: Two-part urethane
- Viscosity: 100 000 cP
- Mix ratio: 1:2
- Cure time: 24 hrs.
- Shear strength: 930 PSI
- Colour: Off-white



LOCTITE

Model No.	Mfg. No.	Size	Price /Each
AD900	29348	50-ml Dual Cartridge	21.50
AD422	29350	400-ml Dual Cartridge	118.00

HYSOL® E-20NS EPOXY ADHESIVE

- Bonds on aluminum, stainless steel and other metals, as well as glass, ceramics, and plastics
- Well suited for use on vertical surfaces to avoid run-off
- Metal bonder, non-sag, high peel and shear
- 20 minutes worklife
- 2:1 mix ratio (resin:hardener)
- 2000-4000 PSI overlap shear strength
- Colour: Light tan



LOCTITE

Model No.	Mfg. No.	Size	Price /Each
AC349	29334	50 ml	18.80

H3151 SPEED BONDER™ METAL BONDER

- Extend open time allows for adjustment of parts
- Excellent bond strength on aluminum and steel
- Impact and peel resistant
- 50 ml dual cartridge
- Colour: Pale yellow



LOCTITE

Model No.	Mfg. No.	Description	Price /Each
AC344	83015	H3151	23.20

H4500™ SPEED BONDER™ STRUCTURAL ADHESIVE

- High strength structural adhesive for metals
- Fast fixture metal bonder
- Chemistry: Two-part acrylic
- Low viscosity: 45 000 cP
- Mix Ratio: 10:1
- Cure speed: Fixture -15 min., full - 24 hrs.
- Shear Strength: 3355 PSI
- Colour: Grey



LOCTITE

Model No.	Mfg. No.	Size	Price /Each
AD428	83041	490-ml Dual Cartridge	91.20

H800™ SPEED BONDER™ STRUCTURAL ADHESIVE, FAST FIXTURE

- Medium fixture time, high performance adhesive with excellent peel strength on multiple substrates, especially aluminum
- Two-part acrylic
- 15 minutes work time, 30 minutes fixture time, 24 hrs cure time
- 3250 PSI shear strength
- Colour: Green



LOCTITE

Model No.	Mfg. No.	Size	Price /Each
AD134	996453	50 ml Dual Cartridge	20.00
AD897	36160	490-ml Dual Cartridge	95.80

H8600™ SPEED BONDER™

- Extended fixture time, high performance adhesive with excellent impact and shear strength on galvanized steel and aluminum
- Especially designed for severe environments
- Medium work life
- Chemistry: Two-part acrylic
- Viscosity: 86,000 cP
- Mix Ratio: 2:1
- Cure Time: 24 hrs.
- Shear strength: 3355 PSI
- Colour: Blue



LOCTITE

Model No.	Mfg. No.	Size	Price /Each
AD419	38762	400-ml Dual Cartridge	86.80
AD420	38760	40-lb. Pail, Resin	2322.00
AD421	38761	40-lb. Pail, Adhesive	2700.00

PLASTIC/COMPOSITE BONDING STRUCTURAL ADHESIVES

- Bonds a wide variety of materials, such as fiberglass, gel coat, thermoplastics, polycarbonate, ABS, PVC, polyethylene and polypropylene
- Specially formulated to provide UV resistance, high impact resistance and peel resistance

H4800™ SPEED BONDER™ STRUCTURAL ADHESIVE

- Provides extended open time, making it ideal for the assembly and adjustment of large parts
- Excellent peel and impact resistance
- Provides high bond strengths on composites
- Impact resistance
- Chemistry: Two-part acrylic
- Viscosity: 50 000 cP
- Mix Ratio: 10:1
- Fixture time: 35 minutes
- Cure time: 24 hours
- Shear strength: 3930 PSI
- Colour: Light yellow



Model No.	Mfg. No.	Size	Price /Each
AD425	996515	50-ml Dual Cartridge	21.60
AD968	83045	490-ml Dual Cartridge	77.50

H3101™ SPEED BONDER™ GENERAL PURPOSE ADHESIVE

- General purpose, medium viscosity adhesive ideal for bonding a variety of substrates
- Extended fixture time
- Medium work life
- Chemistry: Two-part acrylic
- Viscosity: 75 000 cP
- Mix Ratio: 1:1
- Fixture Time: 25 minutes
- Cure Time: 72 hours
- Shear Strength: 2510 PSI
- Colour: Cream
- NSF/ANSI 61 certified



Model No.	Mfg. No.	Size	Price /Each
AD426	83007	50ml Dual Cartridge	23.20
AD427	83006	400ml Dual Cartridge	67.70

LOCTITE®



MULTIPLE SURFACE BONDING STRUCTURAL ADHESIVES

- Bonds a wide variety of materials, such as metal, ceramics and plastics
- Perfect for the following industries: machining & tooling, recreational vehicles, furniture making/repair, structural building components, appliances

330™ DEPEND® NO-MIX ADHESIVE

- A high viscosity adhesive for a wide range of materials including metal, wood, ferrite, ceramic and plastic
- For rough or porous surfaces
- Ideal for gap distances up to 0.030"
- Fixtures in 5 minutes, full in 24 hrs.
- Provides a shear strength of 3300 PSI
- Withstands temperatures to 250°F
- Recommended 7387 primer
- Colour: Amber



LOCTITE

Model No.	Mfg. No.	Size	Price /Each
AB357	1690727	25 ml Kit*	44.20
AC329	1691005	250 ml Kit**	114.00

*Contains 25 ml syringe of Depend 330 and 25 g. aerosol can activator, 7387.

** Contains 250 ml tube of Depend 330 and 4.5 fl. oz. aerosol can activator, 7387.

312™ ACRYLIC ADHESIVES

- Ultra fast setting two-step acrylic
- No mixing required
- Should be used in conjunction with Loctite 736 to create a durable bond on close fitting parts
- Colour: Amber



LOCTITE

Model No.	Mfg. No.	Size	Price /Each
AF082	03333	10 ml Kit	35.10
AF083	00144	50 ml Kit	85.30

H3000 SPEED BONDER™ GENERAL PURPOSE

- A low viscosity adhesive
- Ideal for bonding plastics and composites
- Colour: Tan



LOCTITE

Model No.	Mfg. No.	Size	Price /Each
AC343	83001	50 ml Cartridge	23.70
AF084	83000	400 ml Cartridge	67.70

HYSOL® E-00CL FAST SETTING EPOXY

- Ideal for general purpose bonding, potting, or encapsulating
- Works on a variety of plastic, metal, glass, rubber, wood, and ceramic substrates
- Well suited for applications that require a clear bondline
- Flowable and low odour
- 3-5 minutes worklife
- 1:1 mix ratio (resin:hardener)
- 2000-4000 PSI overlap shear strength
- Colour: Clear



LOCTITE

Model No.	Mfg. No.	Size	Price /Each
AC351	29289	50 ml	18.80
AF085	29290	200 ml	59.10
AF086	29291	400 ml	86.40

HYSOL® 1C GENERAL PURPOSE EPOXY

- Bonds, seals, and repairs a wide variety of materials
- For metals, most plastics, and wood
- Alternative formulations are available in grey (6C) and black (11C)
- Gap filling for high temperatures
- 20 minutes worklife
- 2.5:1 mix ratio (resin:hardener)
- 1750 PSI overlap shear strength
- Colour: White



LOCTITE

Model No.	Mfg. No.	Size	Price /Each
AC359	1373425	4 oz. Kit	12.70
AF087	1377344	1 gal. Kit	370.00
AF088	1377777	60-lb. Pail, Resin	1762.00
AF089	1377780	40-lb. Pail, Hardener	2101.00

HYSOL® E-20HP HIGH PERFORMANCE EPOXY

- Bond strengths to a wide variety of plastics and metals
- Ideal for general purpose industrial assemblies
- High strength, peel, shear and rubber toughened
- 20 minutes worklife
- 2:1 mix ratio (resin:hardener)
- 3000-5000 PSI overlap shear strength
- Colour: Off-white



LOCTITE

Model No.	Mfg. No.	Size	Price /Each
AC348	29314	50 ml Dual Cartridge	18.80
AF090	29315	200 ml Dual Cartridge	73.30
AB926	29316	400 ml Dual Cartridge	122.00
AF091	29317	5 gal. Pail, Resin	3639.00
AF092	29318	5 gal. Pail, Hardener	3639.00

HYSOL® E-30CL EPOXY

- Glass bonder, low viscosity, impact resistant
- 30 minutes worklife
- 2:1 mix ratio (resin:hardener)
- 2000-4000 PSI overlap shear strength
- Colour: Ultra clear



LOCTITE

Model No.	Mfg. No.	Size	Price /Each
AC350	29329	50 ml	18.80
AF093	29330	200 ml	69.80
AF094	29331	500 ml	116.00

HYSOL® E-60NC POTTING COMPOUND

- Bonding, potting and encapsulating electrical components which are sensitive to corrosion caused by traditional epoxies
- Use in electronic applications, for component attachment to boards, housing assembly and potting
- Non-corrosive, low viscosity
- 60 minutes worklife
- 1:1 mix ratio (resin:hardener)
- 1000-3000 PSI overlap shear strength
- Colour: Black opaque



LOCTITE

Model No.	Mfg. No.	Size	Price /Each
AC354	29324	50 ml Dual Cartridge	17.60
AF095	29325	200 ml Dual Cartridge	59.10
AF096	29326	400 ml Dual Cartridge	93.80
AF097	29327	5 gal. Pail, Resin	2665.00
AF098	29328	5 gal. Pail, Hardener	2665.00

331™ STRUCTURAL ADHESIVE ULTRA-FAST FICTURE

- Toughened, activator-cure acrylic
- Acid-free, non-corrosive to sensitive parts
- Fixtures in 20 seconds and develops full strength in 30 minutes
- Excellent high temperature resistance
- Ideal for bonding close-fitting metals and magnets



LOCTITE

Model No.	Mfg. No.	Size	Price /Each
AD126	1057673	25-ml syringe	44.60

50 ML DUAL CARTRIDGE PNEUMATIC APPLICATORS

- Hand held, pneumatically operated dispenser
- Convenient, cost-effective method for the consistent application of two-part adhesives with minimal effort and waste



LOCTITE

Model No.	Mfg. No.	Ratio	Price /Each
AB900	97042	1:1, 2:1	487.00
AF100	1493310	10:1	449.00

400 ML DUAL CARTRIDGE PNEUMATIC APPLICATORS

- Hand held, pneumatically operated meter mix dispenser
- Suited for production line applications
- Adjustable dispense rates set via the integral air pressure regulator



LOCTITE

Model No.	Mfg. No.	Ratio	Price /Each
AB902	983439	1:1, 2:1	845.00
AE003	985249	10:1	764.00

50 ML MANUAL APPLICATOR

- Ergonomically designed for the hand delivery of adhesives and fluids directly from their original package.

DISPENSES:

- Two component epoxies
- Two component urethanes
- Two component methacrylates







Viscosity: High to paste

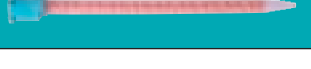

LOCTITE

Model No.	Mfg. No.	Ratio	Price /Each
AB347	98472	1:1, 2:1	67.00
AD129	1034026	10:1	95.00

STATIC MIX NOZZLES AND ACCESSORIES

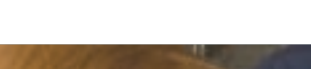
	Model No.	Mfg. No.	Description	Package Quantity	Price /Each
	AD902	98444	50 ml square mix nozzle, luer/stepped combo tip, 3.25". Overall length, 5.3 mm ² , 16 elements; 1:1, 2:1 mix ratios	10	10.90
	AC368	98473	50 ml Square Mix Nozzle, Luer/Stepped combo tip, 4.5". Overall length, 5.3 mm ² , 24 elements; 1:1, 2:1, 4:1 mix ratios	10	17.40
	AB345	98455	50 ml mix nozzle, stepped tip, 6.0". Overall length, 6.35 mm diameter, 21 elements; 1:1, 2:1, 4:1 mix ratios	10	13.40
	AD128	1034575	50 ml-S mix nozzle, stepped Tip, 6.2". Overall length, 6.35 mm ID, 20 elements; 10:1-S cartridges only	10	20.20
	AD934	98474	200/400 ml square mix nozzle, stepped Tip, 5.1". Overall length, 7.5 mm ² , 24 elements; 1:1, 2:1 mix ratios	10	26.90
	AD932	98457	200/400 ml mix nozzle, stepped tip, 8.8". Overall length, 8 mm diameter, 24 elements; 1:1, 2:1 mix ratios	10	26.10
	AD437	1084255	490 ml mix nozzle, stepped tip, 9.1". Nozzle length, 8 mm diameter, 10:1 mix ratio	10	29.10
	AD438	1084092	490 ml mix nozzle, stepped tip, 11.2". Nozzle length, 10 mm diameter, 10:1 mix ratio	10	33.30



SAFETY

GLOVES
TRAFFIC CONTROL
SPILL CONTROL
EYEWEAR



PROFESSIONAL GLUE GUNS

- Perfect for light-duty carton sealing or small manufacturing projects
- Accepts 7/16" diameter regular glue sticks
- Trigger design for better grip control
- Features precise, even adhesive distribution
- 120 volts / 80 watts heater
- Comes with metal wire stand

Model No. PE339
Price/Each \$41.75



aurora tools®

HEAVY-DUTY GLUE GUNS

- Ideal for medium to heavy-duty applications
- Accepts 7/16" diameter regular glue sticks
- Ergonomic trigger design for better grip and comfort
- Features precise, even adhesive distribution
- Illuminated on/off switch
- 120 volts / 100 watts heater
- Comes with metal wire stand

Model No. PE340
Price/Each \$110.00



aurora tools®

GLUE STICKS

Model No.	Appearance	Viscosity	Melting Point	Typical Applications	Dimensions"	Qty/Box	Price/Each
PE341	Clear	11000-13000	77-82°C/170-180°F	High strength, high temp, for non porous materials such as metal and plastics	7/16 x 4	2000	0.30
PE342	Clear	11000-13000	77-82°C/170-180°F	High strength, high temp, for non porous materials such as metal and plastics	7/16 x 10	803	0.63
PE343	Amber	5000	95°C/203°F	For porous materials such as corrugated boxes or wood	7/16 x 15	536	0.95
PE541	Clear	9400	80°C/176°F	All temp. all purpose for porous and non-porous materials	7/16 x 10	803	0.63

20 HEAVY DUTY SPRAY ADHESIVE

- Can be used to bond many different substrates, including wood, plastics, soft foams, fabrics and metal
- High strength, fast grabbing adhesive forms a powerful, permanent bond
- Net Volume: 13.8 oz.

Model No. AF163
Price/Each \$11.10



27 MULTI-PURPOSE SPRAY ADHESIVE

- Extremely versatile adhesive for lightweight applications
- Fast tacking mist spray adhesive with very little soak in on porous substrates
- Ideal for bonding paper, cardboard, plastic films, soft foam, and fiberglass insulation
- Net Volume: 13.05 oz.

Model No. AF164
Price/Each \$10.10



76 HIGH TACK ADHESIVE

- Bonds fabric, paper, cork, foil, rubber, etc.
- Bonds to themselves and to metal, wood, glass and other surfaces
- 24 oz. can
- Net volume: 18.1 oz.

Model No. PA002
Price/Each \$21.10



SUPER 77 SPRAY ADHESIVE

- Ideal for permanently attaching cartons, foams, paper, foils, cardboard, carpeting, cloth fabric
- Other lightweight materials to painted or unpainted metals, wood, cardboard and themselves
- 24 oz. can
- Net volume: 16.75 oz.

Model No. PA003
Price/Each \$18.20



72 PRESSURE SENSITIVE ADHESIVE

- A fast holding strength, aggressive tack and repositionable adhesive. Precise spray control, wide spray pattern and low soak-in. Colour: Blue.
- Polyethylene film and foam bonding, carpet bonding
- Temporary positioning and holding fabric and paper
- Pipe insulation lap adhesive
- Swimming pool liners
- 24 oz. can
- Net volume: 17.33 oz.

Model No. AA556
Price/Each \$17.20



90 HIGH STRENGTH ADHESIVE

- Adheres particle board, polyethylene, polypropylene and rubber to wood metal and many other materials
- Fast contact strength, yet needs only 1 to 2 minutes of drying time
- Colour: Transparent
- 24 oz. can
- Net volume: 17.6 oz.

Model No. PA001
Price/Each \$24.20



3M SCOTCH® ADHESIVE REMOVER PENS

- Use it to prepare surfaces for bonding, remove tape residue, or clean small areas after abrading
- Convenient pen tip that allows precise surface cleaning
- Ideal for desks, workstations or toolboxes
- Small enough to carry in your pocket
- 12 pens per case

Model No. PC692
Price/Each \$6.98

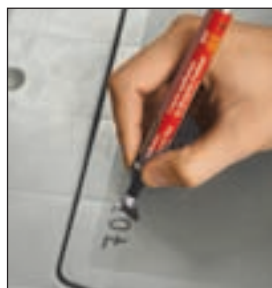

AC50 SPRAY ADHESIVE

- General purpose spray adhesive
- Fast tack
- Web spray pattern
- Bonds to most lightweight materials
- Size: 12 oz.

Model No. AE850
Mfg No. 82758
Price/Each \$10.90



T.S.P.

- Trisodium Phosphate
- All purpose cleaner
- Prepares surfaces for painting
- Removes wax and grease
- Cleans garage floors and driveways
- Aids in restoring paint brushes

Model No.	Size	Price /Each
AB725	2 kg. box	10.30
AC318	4 litre concentrate	7.26



PURE TURPENTINE

- Thins varnishes, paints and enamels
- Cleans surfaces and brushes

Model No.	Size	Price /Each
AB723	3.78 L bottle	54.20



RECORDSOL PAINT THINNER

- Low odour mineral spirits
- Ideal as paint thinner, brush cleaner and all purpose household cleaner
- For floors, woodwork, grease stains, etc.

Model No.	Size	Price /Each
AB706	4 L bottle	16.10
AB707	20 L pail	79.30
AB721	205 L drum	782.00



ACETONE

- Thins fibreglass resin mixes
- Dissolves 2-part epoxies
- Cleans tools and brushes used for epoxies and lacquers

Model No.	Size	Price /Each
AB722	3.78 L can	24.60



BATTERY TERMINAL PROTECTOR

- Dark Red Viscous Liquid
- Plastic Safe: Yes
- Flashpoint: Less than -18°C
- Specially designed to protect battery terminals from corrosion, a leading cause of hard starting and battery failure
- Provides a lead-free soft protective coating



Model No.	Mfg. No.	Size	Price /Each
AE952	75046	213 g	13.58



AIR TOOL OIL

- Preserves and maintains internal seals and mechanisms present in most hand-held air tools
- Lubricates under high pressure to fine tolerances
- Resists moisture induced corrosion, maximizing the service life and performance of your air tools
- Contains no silicone



Model No.	Size	Price /Each
AA091	8 oz. poly bottle	5.96
AA090	4 L jug	52.80



BATTERY CLEANER W/ACID INDICATOR

- Yellow Foam
- Plastic Safe
- Slow evaporation rate
- Instantly detects leaks and neutralizes acid
- Removes corrosion by-products
- Just spray on and rinse off



Model No.	Mfg. No.	Size	Price /Each
MLP160	75097	312 g	8.307.72



BATTERY EQUALIZERS

- Restorative fluid doubles the life of any voltage lead/acid battery
- Save 25% on recharge time
- For use on lift truck and golf cart fleets and many more



Model No.	Size	Price /Each
AA893	500 ml	33.30
AB476	4L	228.00



Can't find what you're looking for?
Call us today!



BATTERY ACID NEUTRALIZER

- Safely neutralizes sulphuric acid spills on skin, clothing and battery box
- Spray battery box regularly to keep terminals and battery clean



Model No.	Size	Price /Each
AA773	198 g	7.58



INDUSTRIAL QUICK-MARK™ INVERTED MARKING PAINT

- Offers the largest tip size for the highest delivery rate
- Offers the most amount of solids ensuring bold, bright and visible markings in one pass
- Adheres to gravel, concrete, grass and soil even in the harshest temperatures and inclement weather conditions
- Features advanced UV-resistant, fast drying formula that will not fade in extreme sun and will penetrate and adhere to hot, cold or wet surfaces
- Offers a patent locking, non clogging tip that ensures use in the toughest condition while also keeping the tip from coming loose or falling off even with repetitive wand usage
- Opening on the Glove Grip™ cap is 50% wider than any other cap design on the market to accommodate work gloves
- Ideal for applications such as marking gas, water, electrical, phone/telecommunication, sewer/drain and other utility lines as well as proposed excavation, road and survey marking
- Available in both water based formulation for moderate-term markings and solvent-based formulation for long lasting applications
- VOC/MIR compliant



Model No.	Colour	Size Can (Net)	Price /Each
WATER BASED APWA COLOURS			
NC332	Utility Yellow	20 oz. (17 oz.)	5.19
NC331	Brilliant White	20 oz. (17 oz.)	5.19
WATER BASED FLUORESCENT COLOURS			
NC334	Safety Red	20 oz. (17 oz.)	5.19
NC335	Pink	20 oz. (17 oz.)	5.19
NC336	Caution Blue	20 oz. (17 oz.)	5.19
NC337	Safety Green	20 oz. (17 oz.)	5.19
NC338	Red /Orange	20 oz. (17 oz.)	5.19
NC333	Orange	20 oz. (17 oz.)	5.19
SOLVENT BASED APWA COLOURS			
NC328	Red	20 oz. (17 oz.)	5.19
NC326	Blue	20 oz. (17 oz.)	5.19
NC329	Green	20 oz. (17 oz.)	5.19
NC327	Bright Orange	20 oz. (17 oz.)	5.19
NC325	High Visibility Yellow	20 oz. (17 oz.)	5.19
NC324	Utility White	20 oz. (17 oz.)	5.19
SOLVENT BASED FLUORESCENT COLOURS			
NC322	Safety Red	20 oz. (17 oz.)	5.19
NC323	Neon Green	20 oz. (17 oz.)	5.19
NE260	Purple	20 oz. (17 oz.)	5.19
NE262	Hot Pink	20 oz. (17 oz.)	5.19
NC320	Red/Orange	20 oz. (17 oz.)	5.19
NC321	Orange	20 oz. (17 oz.)	5.19
SOLVENT BASED GENERAL PURPOSE			
NC330	Asphalt Black	20 oz. (17 oz.)	5.19
AD361	Clear	20 oz. (17 oz.)	5.19

MARKING WANDS

- Constructed of durable, rugged plastic and lightweight steel
- Comfortable pistol grip for easy handling and marking
- Apply a uniform 1" to 1 1/2" width of paint

SPOTTER HAND HELD SHORT WAND 12"

Model No. NC309
Price/Each \$40.76



HAND HELD LONG WAND 34"

Model No. NC310
Price/Each \$42.46



INDUSTRIAL OVERHEAD MARKING PAINT

- Overhead marking paint sprays in an upright position, dries fast and is a low odour formula
- Penetrates and clings to uneven surface
- Mine marking, excavation and bridge marking
- Bright fluorescent colours • Fast drying
- Low odour • 20-oz. cans
- Case Qty: 12 cans • VOC & MIR compliant

Application: For use in marking mines, underground utilities, construction, excavation sites and bridges

Priced per Can

Model No.	Colour	Size Can (Net)	Price /Each
KP091	Fluorescent Red	20 oz. (12 oz.)	9.51
KP092	Fluorescent Orange	20 oz. (12 oz.)	9.51
KP093	Fluorescent Green	20 oz. (12 oz.)	9.51



CONSTRUCTION INVERTED MARKING PAINT

- This water-based formula is especially designed for the rigorous demands of construction, excavation, surveying, landscaping and other commercial operation
- Best resistance to early fading and chalking
- Excellent visibility on concrete, pavement, dirt, gravel, grass and more
- Sprays at any angle: upright, horizontal, inverted
- For use on: Utility, construction, excavation, surveying, landscape, golf course markings
- Container size: 20 oz.
- Surface coverage: 400 linear ft at 1 Inch



KP459

RUST-OLEUM

Model No.	Mfg. No.	Colour	Price /Each
COLOURS			
KP459	264693	Clear	5.96
KP452	264692	White	5.96
KP453	264696	Safety Red	5.96
KP455	264694	Caution Blue	5.96
FLUORESCENT COLOURS			
KP456	264695	High Visibility Yellow	5.96
KP457	264699	Fluorescent Red Orange	5.96
KP458	264700	Fluorescent Green	5.96
KP454	264702	Fluorescent Pink	5.96
KP460	264697	Fluorescent Orange	5.96

PRECISION INVERTED MARKING PAINT

- Creates accurate, easy-to-read markings in bright, durable colors
- Resists early fading and chalking
- Adheres to hot surfaces; can be sprayed in the cold (as low as 25°F)
- For use on: Utility, construction, excavation, surveying, landscaping
- Container size: 20 oz.
- Surface coverage: Approximately 600-700 linear feet at 1 in. wide



KP461

RUST-OLEUM

Model No.	Mfg. No.	Colour	Price /Each
SOLVENT-BASED COLOURS			
KP461	201516	Orange	6.91
KP462	203022	Caution Blue	6.91
KP463	203024	Caution Yellow	6.91
KP464	203025	High Visibility Yellow	6.91
KP465	203027	Fluorescent Orange	6.91
KP466	203028	Fluorescent Red Orange	6.91
KP467	203029	Safety Red	6.91
KP468	203030	White	6.91
KP469	1601838	Clear	6.91
WATER-BASED COLOURS			
KP470	203031	Caution Blue	6.91
KP471	203034	High Visibility Yellow	6.91
KP472	203035	Alert Orange	6.91
KP473	203036	Fluorescent Orange	6.91
KP474	203038	Safety Red	6.91
KP475	203039	White	6.91
KP476	1801838	Clear	6.91
KP477	1861838	Fluorescent Pink	6.91

INDUSTRIAL LINE-UP® STRIPING PAINT

- Crisp, clean line and durable performance
- Highly pigmented formulas fortified with optical brighteners for eye catching lines
- Available in non-burning water based formula for grass fields, solvent based formulas for pavement and removable formulas for synthetic turf surfaces that require quick change



LINE-UP® ATHLETIC FIELD STRIPING PAINT FOR GRASS

- Non-burning formula, safe for all grass fields, will not harm grass or stunt its growth
- VOC compliant



Model No.	Colour	Size (Can/Net)	Price /Each
NE333	Athletic White	20 oz (18 oz)	8.60
NE334	Athletic Yellow	20 oz (18 oz)	8.60
AD365	Athletic Orange	20 oz (18 oz)	8.27
AD366	Athletic Black	20 oz (18 oz)	8.27
AD367	Athletic Navy	20 oz (18 oz)	8.27
AD368	Athletic Fluorescent Orange	20 oz (18 oz)	8.27
AD369	Athletic Fluorescent Green	20 oz (18 oz)	8.27
NI795	Athletic Turf Green	20 oz (18 oz)	8.60

LINE-UP® PAVEMENT STRIPING PAINTS

- For striping blacktop, concrete, curbs or other smooth, hard surfaces
- Traffic ready in 60 minute, approximately 250 linear feet per can, excellent bleed retention and highly visible

Model No.	Colour	Size (Can/Net)	Price /Each
NE335	Highway White	20 oz (18 oz)	10.90
NE336	Highway Yellow	20 oz (18 oz)	10.90
NE337	Handicap Blue	20 oz (18 oz)	10.90
NE338	Firelane Red	20 oz (18 oz)	10.90
NE339	Cover Up Black	20 oz (18 oz)	10.90

ATHLETIC FIELD STRIPING PAINT

- Water-based paint produces durable, long-lasting lines that withstand weather and wear
- Sprays upside-down for easy use
- For use on: Athletic fields, playgrounds, golf courses
- Container size: 20 oz.
- Surface coverage: Approximately 100-200 linear ft at 3" wide (30-60 m at 7.6 cm)



KP449

RUST-OLEUM

Model No.	Mfg. No.	Colour	Price /Each
KP449	206043	White	11.60
KP450	206045	Yellow	11.60

STRIPING PAINT APPLICATORS

34" LINE UP® STRIPING WAND

- For use on line touch up and stenciling
- Rugged, durable design with trigger operation

Model No. NI441
Price/Each \$54.50



ATHLETIC FIELD STRIPING MACHINES

- Made of durable 18-gauge steel, features a collapsible design for easy storage, a convenient handle bar to control paint applied and striping width can be adjusted from 2" to 4"
- Holds up to 12 cans
- 10" wheels provide an even ride over rough or uneven surface such as grass, dirt or gravel

Model No. NE341
Price/Each \$274.63



PAVEMENT STRIPING MACHINES

- Made of durable 18-gauge steel, features a collapsible design for easy storage, a convenient handle bar to control paint applied and striping width can be adjusted from 2" to 4"
- Holds up to 12 cans
- 7" wheels provide a smooth ride over hard surfaces such as pavement, concrete, blacktop or metal

Model No. NE340
Price/Each \$274.63



ATHLETIC FIELD STRIPING MACHINE

- The large wheels move easily through high grass and make striping fast and easy
- Adjustable for 3-6"-wide lines
- Includes convenient storage compartment — holds up to 12 extra cans
- Collapsible handle for easy storage
- Sturdy steel construction
- Colour: Yellow

Model No. KP451
Mfg. No. 206346
Price/Each \$249.00



RUST-OLEUM

TRAFFIC ZONE STRIPING PAINT

- Apply this weather-resistant coating to concrete, gravel or pavement for durability you can count on
- Use with bulk-spray machine, brush or roller
- For use on: Parking lots, stadiums, curbs, athletic facilities
- Size: 1 Gal
- Surface coverage: 410-540 linear feet



KP405

RUST-OLEUM

Model No.	Mfg. No.	Colour	Price /Each
KP405	2348402	Yellow	51.90
KP406	2391402	White	51.90

2300 INVERTED STRIPING PAINT

- Apply this weather-resistant coating to concrete, gravel or pavement for durability you can count on
- Dries in less than 10 minutes
- Guaranteed not to clog
- Highest amount of solids for complete coverage
- For use on: Parking lots, stadiums, curbs, athletic facilities
- Container Size: 20 oz
- Surface Coverage: 800 linear feet at 2 inch



KP614

RUST-OLEUM

Model No.	Mfg. No.	Colour	Price /Each
KP614	2326838	Blue	15.30
KP615	2348838	Yellow	15.30
KP616	2364838	Red	15.30
KP617	2378838	Flat Black	15.30
KP618	2391838	White	15.30

Ask us about volume prices!
In many cases you will benefit from quantity prices.

PAINT & PAINTING SUPPLIES

PAVEMENT STRIPING MACHINE

- Make crisp, accurate stripes
- Works on a variety of terrains and makes applying straight lines fast and easy
- Collapsible handle
- Adjustable for 2" to 4" wide lines
- Includes convenient storage compartment — holds up to 12 extra cans
- Colour: Yellow

Model No. KP407
Mfg. No. 2395000
Price/Each \$210.00

RUST-OLEUM



STRIPING WAND

- This single-wheeled, rolling tool applies striping paint with comfort and precision
- Light-touch spray provides easy control and reduces finger fatigue
- Constructed of steel and plastic
- Colour: Gray

RUST-OLEUM



Model No.	Mfg. No.	Series	Price /Each
KP408	2388000	High Performance Striping Wand	70.10
KP409	2393000	Industrial Choice Striping Wand	53.80

5-BALL INTERIOR-EXTERIOR INDUSTRIAL MAINTENANCE PAINT

- For industrial maintenance and touch-up applications
- Dry in 12 minutes or less
- Original *No runs, no drips, no errors!*™ formula!
- Superior performance, both indoors and outdoors
- VOC-compliant acrylic lacquer formula, free of lead hazards
- Hard, protective, durable finish
- High amount of solids assures maximum coverage with excellent adhesion
- Tough, high-gloss finish
- Uniform coverage
- No recoat window, recoat anytime
- Case Qty: 6 cans

Applications: Any metal or wood surface, including motors, tools, pipelines, conduit, ducts, drums, cabinets, furniture, and for color coding steel and lumber.

KRYLON
INDUSTRIAL



Priced per Can

Model No.	Colour	Size Can (Net)	Price /Each
NA455	Gloss White OSHA	16 oz. (12 oz.)	10.70
NA463	Gloss Black OSHA	16 oz. (12 oz.)	10.70
NA469	Smoke Grey	16 oz. (12 oz.)	10.70
NA482	Daisy Yellow OSHA	16 oz. (12 oz.)	10.70
NA484	Regal Blue	16 oz. (12 oz.)	10.70
NA536	Cherry Red	16 oz. (12 oz.)	10.70
NA552	Leather Brown	16 oz. (12 oz.)	10.70
NA480	Sun Yellow	16 oz. (12 oz.)	10.70
NA535	Emerald Green	16 oz. (12 oz.)	10.70
NA478	John Deere Yellow	16 oz. (12 oz.)	10.40
NA532	John Deere/Case Gr.	16 oz. (12 oz.)	10.40
NA556	Fluorescent Yellow/Orange	16 oz. (12 oz.)	11.80
NA555	Fluorescent Red/Orange	16 oz. (12 oz.)	11.80
PRIMER			
NA448	Ruddy Brown Primer	16 oz. (12 oz.)	10.20
NA449	Grey Primer	16 oz. (12 oz.)	10.20
AA044	All-Purpose White Primer	16 oz. (12 oz.)	10.20

SPRAYSMART™ MARKING PAINT - APPLICATOR

- SpraySmart™ is a non-aerosol marking paint system
- Marking paint is supplied in a flexible pouch using the unique compression technology of the SpraySmart™ device
- The system is propellant-free which eliminates the requirement for costly disposal procedures
- Fits into any existing marking wand
- Powered by a rechargeable battery
- Designed to fully empty each paint pouch for no waste
- A fully charged battery will spray up to 48 pouches
- Full Charge Time: 4-6 hours

Model No. KP631
Mfg. No. 275124
Price/Each \$399.00

RUST-OLEUM



SPRAYSMART™ MARKING PAINT

- Easier and safer to transport than traditional aerosol cans
- Coverage: Approximately 500-600 linear feet at 1 in. wide
- Dry Time: 5-10 minutes
- Non-clogging spray tip
- Partially used pouches can be stored for future use in order to eliminate waste



RUST-OLEUM

Priced per Pouch

Model No.	Mfg. No.	Colour	Price /Each
KP632	275092	High Visibility Yellow	5.75
KP633	275089	Safety Red	5.75
KP634	278466	Caution Yellow	5.75
KP635	275086	Caution Blue	5.75
KP636	278383	APWA Orange	5.75
KP637	275085	Fluorescent Orange	5.75
KP638	275088	Fluorescent Pink	5.75
KP639	275087	Fluorescent Green	5.75

Model No.	Mfg. No.	Colour	Price /Each
KP640	275384	Fluorescent Red Orange	5.75
KP641	275090	Fluorescent Red	5.75
KP642	278382	Safety Green	5.75
KP643	278381	Safety Purple	5.75
KP644	278278	Black	5.75
KP645	278278	Silver	5.75
KP646	275091	White	5.75

INDUSTRIAL WORK DAY™ AEROSOL ENAMEL PAINT

- Offers an economical solution to marking, colour coding and miscellaneous spray paint needs where long term quality and durability are not required.
- Economical
- Dries to touch in 12 minutes
- VT alkyd formulation
- Case Qty: 12 cans

Application: For use on ceramic, plaster, glass, metal, wood, and most other surfaces

KRYLON
INDUSTRIAL



Priced per Can

Model No.	Colour	Size Can (Net)	Price /Each
NI472	Gloss white	16 oz. (10 oz.)	4.99
NI507	Flat white	16 oz. (10 oz.)	4.99
NI473	Yellow	16 oz. (10 oz.)	4.99
NI474	Orange	16 oz. (10 oz.)	4.99
NI475	Gloss red	16 oz. (10 oz.)	4.99
NI476	Blue	16 oz. (10 oz.)	4.99
NI508	Sky blue	16 oz. (10 oz.)	4.99
NI509	True blue	16 oz. (10 oz.)	4.99
NI510	Brown	16 oz. (10 oz.)	4.99
NI477	Aluminum	16 oz. (10 oz.)	4.99
NI515	Green	16 oz. (10 oz.)	4.99
NI492	Flat black	16 oz. (10 oz.)	4.99
NI512	Grey	16 oz. (10 oz.)	4.99
NI513	Dark grey	16 oz. (10 oz.)	4.99
NI478	Gloss black	16 oz. (10 oz.)	4.99
NI479	Grey primer	16 oz. (10 oz.)	4.99
NI480	Red primer	16 oz. (10 oz.)	4.99

INDUSTRIAL COLORWORKS™ MAINTENANCE CHOICE™ ENAMELS

ColorWorks™ is a fast drying, modified alkyd enamel for multi-purpose industrial applications. ColorWorks™ provides excellent performance for both interior and exterior general purpose applications and will resist chipping, fading, and peeling. Dries fast, in 15 minutes.

FEATURES:

- High paint solids formula for excellent hide
- Excellent high gloss retention
- Fast drying
- Interior/exterior use
- Value and quality
- Acrylic enamel formulation
- Case Qty: 6 cans

Applications: General industrial maintenance and touch-up work



Model No	Colour	Size Can (Net)	Price /Each
NI789	Gloss Black	16 oz. (11 oz.)	7.47
KP016	Flat Black	16 oz. (11 oz.)	7.47
NI790	Gloss White	16 oz. (11 oz.)	7.47
NI810	Flat White	16 oz. (11 oz.)	7.47
KP017	Dark Machinery Gray	16 oz. (11 oz.)	7.47
KP094	Industrial Gray	16 oz. (11 oz.)	7.47
KP018	Safety Blue	16 oz. (11 oz.)	7.47
NI809	Royal Blue	16 oz. (11 oz.)	7.47
KP095	Navy Blue	16 oz. (11 oz.)	7.47
KP096	Emerald Green	16 oz. (11 oz.)	7.47
KP019	Hunter Green	16 oz. (11 oz.)	7.47
KP020	Safety Red	16 oz. (11 oz.)	7.47
NI805	Cherry Red	16 oz. (11 oz.)	7.47
KP021	Safety Orange	16 oz. (11 oz.)	7.47
NI808	Equipment Orange	16 oz. (11 oz.)	7.47
KP022	Safety Yellow	16 oz. (11 oz.)	7.47
KP097	Walnut Brown	16 oz. (11 oz.)	7.47
KP023	Silver Aluminium	16 oz. (11 oz.)	7.47
KP024	Grey Primer	16 oz. (11 oz.)	7.47
KP025	Red Oxide Primer	16 oz. (11 oz.)	7.47

INDUSTRIAL CHOICE SPRAY PAINT

- For indoor/outdoor industrial-maintenance use
- Extra-wide comfort nozzle prevents finger fatigue and sprays from any angle, even upside down
- Resists chipping, fading and peeling
- For use on: Tools, motors, furniture, equipment, color coding, ladders, lockers
- Container size: 16 oz.
- Surface coverage: Approximately 22 sq. ft. (2 m²)



KP430

RUST-OLEUM

Model No.	Mfg. No.	Colour	Price /Each
COLOURS			
KP430	202214	Machine Gray	9.24
KP431	214645	ANSI 61 Light Gray	9.24
KP432	1614830	Dull Aluminium	9.24
KP433	1622830	Regal Blue	9.24
KP439	1676830	Ultra-Flat Black	9.24
KP440	1678830	Semi-Flat Black	9.24
KP441	1679830	Glossy Black	9.24
KP442	1684830	Dove Gray	9.24
KP443	1686830	Universal Gray	9.24
KP444	1690830	Flat White	9.24
KP445	1692830	Glossy White	9.24
SAFETY COLOURS			
KP434	1624830	Safety Blue	9.24
KP435	1633830	Safety Green	9.24
KP436	1644830	Safety Yellow	9.24
KP437	1653830	Safety Orange	9.24
KP438	1660830	Safety Red	9.24
PRIMER			
KP446	1667830	Red	9.24
KP447	1680830	Gray	9.24

OVERALL® ENAMEL SPRAY PAINT

- Indoor/outdoor formula
- Economical, fast-drying industrial spray
- Great for a variety of spray paint needs, where durability and long-term quality are not required
- Container size: 16 oz.
- Surface coverage: 14 sq. ft. (1.3 m²)



KP503

RUST-OLEUM

Model No.	Mfg. No.	Colour	Price /Each
COLOURS			
KP503	215409	Light Gray	5.26
KP504	V2402830	Black	5.26
KP505	V2403830	White	5.26
KP506	V2404830	Flat Black	5.26
KP507	V2405830	Flat White	5.26
KP508	V2407830	Red	5.26
KP509	V2408830	Blue	5.26
KP510	V2409830	Yellow	5.26
PRIMER			
KP502	215405	Red Primer	5.26

HIGH PERFORMANCE V2100 SPRAY PAINT

- This advanced formula provides the best-possible corrosion protection with easy, one-coat coverage and long-lasting color, gloss and durability
- Tough, professional finish — superior resistance to chipping, cracking and peeling
- High-output tip covers 50% faster
- Extra-wide comfort nozzle prevents finger fatigue and sprays from any angle, even upside down
- Surface coverage: 14 sq. ft. (1.3 m²)
- Max operating temperature: 200°F
- For use on: Structural steel, handrails, piping, storage tanks, equipment, machinery
- Container size: 20 oz.
- Accepted for use in Canadian food processing facilities



KP377

RUST-OLEUM

Model No.	Mfg. No.	Colour	Price /Each
COLOURS			
KP377	V2115838	Silver Aluminum	13.40
KP378	V2123838	Light Blue	13.40
KP380	V2125838	Deep Blue	13.40
KP382	V2137838	Dark Green	13.40
KP383	V2138838	Hunter Green	13.40
KP385	V2147838	Industrial Yellow	13.40
KP388	V2164838	Bright Red	13.40
KP389	V2175838	Chestnut Brown	13.40
KP390	V2177838	Semi-Gloss Black	13.40
KP391	V2178838	Flat Black	13.40
KP392	V2179838	Black	13.40
KP393	V2183838	Light Machine Gray	13.40
KP394	V2187838	Dark Machine Gray	13.40
KP395	V2190838	Flat White	13.40
KP396	V2192838	Gloss White	13.40
SAFETY COLOURS			
KP386	V2155838	Safety Orange	13.40
KP384	V2143838	Safety Yellow	13.40
KP387	V2163838	Safety Red	13.40
KP379	V2124838	Safety Blue	13.40
KP381	V2133838	Safety Green	13.40
PRIMER			
KP397	V2169838	Red	13.40
KP398	V2182838	Gray	13.40

PAINT & PAINTING SUPPLIES

TOUGH COAT® REBAR GREEN

- One-system, epoxy paint that prevents rust stains in concrete
- Provides excellent barrier for rebar, steel, metal or other metal support beams
- Resilient and excellent durable finish will withstand all conditions
- Case Qty: 12 cans



Priced per Can



Model No.	Size Can (Net)	Price /Each
NI483	16 oz. (12 oz.)	10.90

HIGH PERFORMANCE V2100 HIGH HEAT SPRAY PAINT

- Provides protection against corrosion and heat, while delivering long-lasting durability
- Tough, professional finish—superior resistance to chipping, cracking and peeling
- High-output tip covers 50% faster
- For use on: Boilers, steam pipes, vents, exhaust pipes, kilns
- Container size: 20 oz.
- Surface coverage: 14 sq. ft. (1.3 m²)
- Max operating temperature: 1000°F
- Accepted for use in Canadian food processing facilities



KP401

RUST-OLEUM

Model No.	Mfg. No.	Colour	Price /Each
KP401	V2116863	Aluminum	13.40
KP402	V2176868	Black	13.40

SPRAY GRIP

- Two finger trigger minimizes fatigue
- Unique locking collar keeps can tightly attached
- Trigger safety lock prevents accidental use
- Keeps hands clean
- Colour: Black



KP403

KP404

RUST-OLEUM

Model No.	Mfg. No.	Description	Price /Each
KP403	243546	Economy	5.34
KP404	241526	Comfort	5.34

ECO-GUARD™ LATEX SPRAY PAINT

- Latex (not water-reducible) paint provides a high gloss and excellent colour retention appearance
- Low odour, contents under pressure formula and MIR compliant make it the safest paint to use indoor or outdoor
- Soap and water clean-up
- Dries fast; in just 20 minutes to the touch
- Other colours are available
- Case Qty: 12 cans

Use on: Metal, wood, masonry, plaster, most plastics, plastic foam and wicker



Priced per Can

Model No.	Colour	Size Can (Net)	Price /Each
NI464	Red (OSHA)	16 oz. (12 oz.)	10.20
NI465	Orange (OSHA)	16 oz. (12 oz.)	10.20
NI466	Yellow (OSHA)	16 oz. (12 oz.)	10.20
NI467	Blue (OSHA)	16 oz. (12 oz.)	10.20
NI468	Gloss White	16 oz. (12 oz.)	10.20
NI469	Satin Grey	16 oz. (12 oz.)	10.20
NI471	Max Flat Black	16 oz. (12 oz.)	10.20
NI470	Grey Primer	16 oz. (12 oz.)	10.80

TOUGH COAT™ ACRYLIC ALKYD ENAMELS

- Specially formulated for a variety of industrial applications
- Ideal for light-to-heavy-duty painting projects, both indoors and outdoors
- Tough, protective coating resists chipping and peeling
- Excellent hiding characteristics, smooth, even coverage
- Fast-drying; dries to the touch in just 15 minutes
- High heat: withstands intermittent temperatures up to 1000°F, and constant temperatures up to 600°F
- Case qty: 12 cans

Applications: Metal, motors, machinery, tools, tool boxes, steel bar railings, conduit, ducts, electrical equipment, pipeline and for marking area



Priced per Can



Model No.	Colour	Size Can (Net)	Price /Each
GENERAL PURPOSE COLOURS			
NA279	Machinery Dark Grey	16 oz. (12 oz.)	8.95
NA280	Machinery Light Grey	16 oz. (12 oz.)	8.95
NA281	Machinery Blue/Grey	16 oz. (12 oz.)	8.95
NA394	Clear Gloss Topcoat	16 oz. (12 oz.)	8.95
NA396	Bright Red	16 oz. (12 oz.)	8.95
NA400	Cherry Red	16 oz. (12 oz.)	8.95
NA401	OSHA Red	16 oz. (12 oz.)	8.95
NA402	Zinger Pink	16 oz. (12 oz.)	8.95
NA403	OSHA Orange	16 oz. (12 oz.)	8.95
NA406	Cordova Brown	16 oz. (12 oz.)	8.95
NA407	Light Beige	16 oz. (12 oz.)	8.95
NA408	OSHA Yellow	16 oz. (12 oz.)	8.95
NA413	Medium Green	16 oz. (12 oz.)	8.95
NA414	OSHA Safety Green	16 oz. (12 oz.)	8.95
NA416	OSHA Blue	16 oz. (12 oz.)	8.95
NA417	Dark Blue	16 oz. (12 oz.)	8.95
NA418	Light Blue	16 oz. (12 oz.)	8.95
NA419	OSHA Purple	16 oz. (12 oz.)	8.95
NA420	Medium Grey	16 oz. (12 oz.)	8.95
NA421	Machinery Grey	16 oz. (12 oz.)	8.95
NA422	Blue/Grey	16 oz. (12 oz.)	8.95
NA423	Industrial Grey	16 oz. (12 oz.)	8.95
NA424	Light Grey	16 oz. (12 oz.)	8.95
NA425	Aluminum	16 oz. (12 oz.)	8.95
NA426	Gold	16 oz. (12 oz.)	8.95
NA427	OSHA Black	16 oz. (12 oz.)	8.95
NA428	OSHA White	16 oz. (12 oz.)	8.95
NA432	Flat White	16 oz. (12 oz.)	8.95
NA433	Semi-Flat Black	16 oz. (12 oz.)	8.95
NA434	Flat Black	16 oz. (12 oz.)	8.95

IMPLEMENT COLOURS

NA397	Allis-Chalmers Orange	16 oz. (12 oz.)	8.95
NA398	Ford Blue	16 oz. (12 oz.)	8.95
NA399	Federal Highway Yellow	16 oz. (12 oz.)	8.95
NA404	International Orange	16 oz. (12 oz.)	8.95
NA410	Caterpillar Yellow (New)	16 oz. (12 oz.)	8.95
NA411	Caterpillar Yellow (Old)	16 oz. (12 oz.)	8.95
NA415	Machine Green	16 oz. (12 oz.)	8.95

PRIMERS

NA287	Red Oxide Rust Control (Non-Sandable)	16 oz. (12 oz.)	8.95
NA288	Grey Rust Control (Non-Sandable)	16 oz. (12 oz.)	8.95
NA290	Light Grey Control (Sandable)	16 oz. (12 oz.)	8.95
NA291	Red Oxide (Sandable)	16 oz. (12 oz.)	8.95

FLUORESCENTS

NA429	Orange	16 oz. (12 oz.)	9.93
NA430	Red	16 oz. (12 oz.)	9.93
NA431	Electric Green	16 oz. (12 oz.)	9.93

HIGH HEAT

NA278	Aluminum	16 oz. (12 oz.)	9.67
NA283	Black	16 oz. (12 oz.)	8.20

See pages 1443 - 1445 for Paint Markers and Crayons



HIGH PERFORMANCE V7400 DTM

- Get outstanding protection and color
- Resists chipping, fading, weathering
- Protects against mild chemicals — ideal for moderate to slightly severe industrial environments
- Two-year rust-proof guarantee—maximum corrosion protection
- For use on: General plant maintenance, machinery, equipment, structural steel, pipes, metal cabinets, lockers, railings, trim, doors, gates, vents, outdoor signage, water towers, agriculture, drilling, coastal applications, vehicle refinishing
- Size: 1 Gal.
- Surface Coverage: 278-509 sq. ft./gal. (6.8-12.5 m²/l)
- Accepted for use in Canadian food processing facilities

RUST-OLEUM

Model No.	Mfg. No.	Colour	Price /Each
COLOURS			
KP410	245387	Flat Black	105.00
KP411	245533	Flat White	105.00
KP412	245403	Gloss Black	105.00
KP413	245406	Gloss White	105.00
KP414	245441	National Blue	105.00
KP415	245443	Navy Gray	105.00
KP421	245484	Silver Gray	105.00
SAFETY COLOURS			
KP416	245474	Safety Blue	119.00
KP417	245476	Safety Green	119.00
KP418	245477	Safety Orange	135.00
KP419	245478	Safety Red	135.00
KP420	245479	Safety Yellow	135.00
PRIMER			
KP422	V7086402	Gray	84.20
KP423	V7696402	Red	84.20



KP410

HIGH PERFORMANCE 9100 DTM EPOXY MASTIC

- Quickly creates a tough, durable, protective surface
- Direct-to-metal (DTM) self priming formula—adheres to a variety of substrates
- Superior long-term resistance to solvents, chemicals, abrasion and impact
- Convenient 1:1 mixing ratio of base and activator - no measuring required
- Two-year rust-proof guarantee—maximum corrosion protection
- For use on: Steel beams, structural steel, towers, concrete floors, conveyors, industrial equipment, storage tanks, sewage treatment basins, non-potable water storage facilities, steel handrails
- Size: 1 Gal.
- Accepted for use in Canadian food processing facilities

Model No.	Mfg. No.	Colour	Price /Each
COLOURS			
KP424	9144402	Safety Yellow	190.00
KP425	9179402	Black	148.00
KP426	9182402	Silver Gray	148.00
KP427	9192402	White	148.00
ACTIVATORS			
KP428	9101402	Standard Acitvator	149.00
KP429	V7696402	Immersion Activator	149.00



KP424

RUST-OLEUM

C740 DTM ALKYD MAINTENANCE PAINT

- Ready-to-use formula provides an easy-to-maintain, high-gloss finish specifically for commercial applications
- Multi-purpose direct-to-metal (DTM) coating
- Convenient—requires no measuring or mixing; can be brushed, rolled or sprayed
- Resists rust, chipping, general weathering, mild chemical fumes and light abrasion
- For use on: Interior & exterior commercial metal applications, metal trim (doors & structural steel), handrails, fixtures, fire escapes, vents, fences, hydrants, cabinets, channels
- Surface coverage: 265-440 sq. ft./gal. (6.5-10.8 m²/l)
- Accepted for use in Canadian food processing facilities



KP478

RUST-OLEUM

Model No.	Mfg. No.	Colour	Price /Each
KP478	255554	Black	70.30
KP479	255558	White	70.30
KP480	255550	Safety Yellow	86.70

RUST TOUGH® ACRYLIC ENAMELS

AEROSOLS

- Complete coverage with one coat
- Dries to touch in 25 minutes; dries to handle in 1 hour
- Superior appearance and colour retention
- Ideal for small touch-up jobs, painting irregular shapes or covering hard-to-reach areas
- For both indoor and outdoor use
- Tough, high-gloss finish resists chipping and peeling
- Acrylic enamels and primers are equipped with EZ Touch® Fanspray® nozzle
- Case Qty: 6 cans



Applications: Steel, aluminum, properly primed metal and wood, structural steel, storage tanks, bar joists, handrails, piping, pipe racks, conveyors, ladders, fencing, machinery, metal doors and marine applications above boot topping.

Note: Not recommended for immersion.



Priced per Can

Model No.	Colour	Size Can (Net)	Price /Each
AEROSOLS			
NA356	Flat Black	20 oz. (15 oz.)	12.56
NA386	Flat White	20 oz. (15 oz.)	12.56
NA360	Gloss Black	20 oz. (15 oz.)	12.56
NA393	Gloss White	20 oz. (15 oz.)	12.56
NA352	Semi-Gloss Black	20 oz. (15 oz.)	12.60
ZB013	Semi-Gloss White	20 oz. (15 oz.)	12.60
NA273	Safety Blue (OSHA)	20 oz. (15 oz.)	12.56
NA286	Safety Green (OSHA)	20 oz. (15 oz.)	12.56
NA322	Safety Orange (OSHA)	20 oz. (15 oz.)	12.56
NA330	Safety Red (OSHA)	20 oz. (15 oz.)	12.56
NA302	Safety Yellow (OSHA)	20 oz. (15 oz.)	12.56
NA326	Equipment Orange	20 oz. (15 oz.)	12.60
NA318	Equipment Yellow	20 oz. (15 oz.)	12.60
NA314	Industrial Yellow	20 oz. (15 oz.)	12.60
NA306	Federal Safety Railing Yellow	20 oz. (15 oz.)	12.60
NA382	Dark Machine Grey (Asa-49)	20 oz. (15 oz.)	12.56
NA368	Light Machinery Grey (Asa-61)	20 oz. (15 oz.)	12.56
NA294	Bright Green	20 oz. (15 oz.)	12.60
NA298	Dark Green	20 oz. (15 oz.)	12.60
NA334	Bright Red	20 oz. (15 oz.)	12.60
NA264	Aluminum	20 oz. (15 oz.)	12.56
NA269	Light Blue	20 oz. (15 oz.)	12.60
NA277	Deep Blue	20 oz. (15 oz.)	12.56
NA346	Chestnut Brown	20 oz. (15 oz.)	12.60
NA342	Tan	20 oz. (15 oz.)	12.56
NA435	Fluorescent Green	20 oz. (15 oz.)	14.60
NA436	Fluorescent Yellow	20 oz. (15 oz.)	14.60
NA437	Fluorescent Orange	20 oz. (15 oz.)	14.60
NA438	Fluorescent Red	20 oz. (15 oz.)	14.60
NA348	Hi-Temp Black	20 oz. (15 oz.)	12.60
PRIMERS			
NA364	Grey Primer	20 oz. (15 oz.)	12.56
NA338	Red Oxide Primer	20 oz. (15 oz.)	12.56
NA375	Zinc-Rich Cold Galvanized Primer	20 oz. (15 oz.)	17.78

ECO-GRADE™ VANDAL MARK & GRAFFITI REMOVER

- Soy based, contains natural, biodegradable ingredients made to replace terpene or petrochemical based products
- Formulated with EPA DFE certified materials
- Quickly and easily removes paint, ink, crayon, magic marker and adhesive residue
- Sprays and clings to vertical surfaces
- Penetrates and dissolves oil based stains quickly



Model No.	Mfg. No.	Size Can (Net)	Price /Each
AD402	A00404000	16 oz. (12 oz.)	14.50

PAINT & PAINTING SUPPLIES

IRON GUARD® ACRYLIC ENAMEL INDUSTRIAL COATINGS™

- High gloss, 100% acrylic, waterborne coating for light to moderate industrial use
- Designed for new construction or maintenance use, can be used directly over prepared substrates, including metal
- Chemical and corrosion resistant, fast drying and outstanding early moisture, flash rust and early rust resistance
- Low odour, outstanding adhesion
- VOC: < 100 g/L (0.83 lbs./Gal)
- Can be used on steel, iron, aluminum, galvanizing, concrete, masonry, wood and over zinc-rich primers in applications such as tank and cylinders, steel fabricated parts, equipment, machinery, metal buildings, select marine structures, piping, handrails and ornamental iron



NI813

Colour	Model No.	Price/Each 1 Gallon	Model No.	Price/Each 5 Gallon
Gloss White	NI813	61.00	KP259	304.00
Gloss Black	NI814	56.70	KP260	283.00
Semi-Gloss Black	NI816	54.90	-	-
Flat Black	KP262	51.50	-	-
Safety Yellow (OSHA)	NI815	64.00	-	-
Safety Red (OSHA)	NI818	93.60	-	-
Safety Blue (OSHA)	KP263	58.00	-	-
Safety Green (OSHA)	KP264	57.70	-	-
Light Machinery Gray (ASA-61)	NI822	56.50	-	-
Safety Orange (OSHA)	KP266	89.80	-	-
Dark Machinery Gray (ASA-49)	KP267	59.20	-	-
New Cat Yellow	KP268	68.70	-	-

RUST TOUGH 250

- For interior/exterior industrial, institutional, commercial and maintenance use in moderate to severe environments
- Rust inhibitive, corrosion resistant alkyd enamel can be applied directly to metal
- Protects against mild chemicals, fumes, oil and grease stains and atmospheric corrosion
- Excellent hide, colour & gloss retention, and superior chip, crack and peel resistance
- Low VOC, CARB compliant < 250 g/L
- Can be used on previously painted surfaces, iron, steel, aluminum, galvanized metal or wood
- Acceptable for use in Canadian food processing facilities



AD345

Colour	1 Gallon Model No.	Price /Each
Safety Yellow	AD350	119.00
Safety Orange	AD358	111.00
Safety Blue	AD359	99.00
Safety Red	AD355	117.00
Gloss White	AD345	116.00
Black	AD349	94.00
Dark Machinery Gray	AD352	104.00
Light Machinery Gray	AD353	99.00
Equipment Yellow	AD356	109.00
PRIMER		
Grey Primer	AD347	92.00
Red Oxide Primer	AD357	80.00

SIERRA METALMAX® DTM ACRYLIC

- This water-based formula contains no VOCs, HAPs or solvent odor and is ideal for schools and settings where paint fumes are an issue
- Superior resistance to corrosion and humidity; excellent color retention
- Fast, convenient, single-component system
- Results in a smooth, washable, professional finish
- Applies direct-to-metal (DTM), including galvanized steel and aluminum; for interior/exterior use
- For use on: Anywhere paint odors or VOC is a concern, food/beverage plants, schools, healthcare, warehouses, metal structures, line equipment
- Size: 1 Gal.
- Surface coverage: 180-545 sq. ft./gal. (4.4-13.4 m²/l)



KP481

RUST-OLEUM

Model No.	Mfg. No.	Colour	Price /Each
KP481	210475	Safety Red	117.00
KP482	210477	Safety Yellow	117.00
KP483	238752	White	107.00
KP484	238753	Safety Blue	117.00
KP485	238755	Gray Primer	100.00

SIERRA S40 EPOXY FLOOR COATING

- This water-based formula contains no VOCs, HAPs or solvent odor and creates a tough, high-gloss finish
- High-performance coating — for concrete floors in moderate to severe industrial settings
- Highly resistant to most chemicals and abrasion
- Easy-to-use, two-component system — order base and activator separately
- For use on: Food/beverage plants, schools, healthcare, office buildings, concrete floors
- Size: 1 Gal.
- Surface Coverage: 125-175 sq. ft./gal. (3.1-4.3 m²/L)
- 200-300 sq. ft./gal. (4.9-7.4 m²/L)
- Accepted for use in Canadian food processing facilities



KP486

RUST-OLEUM

Model No.	Mfg. No.	Description	Price /Each
KP486	208068	Safe Yellow	155.00
KP487	208072	Classic Gray	77.10
KP488	208074	Light Gray	77.10
KP489	208086	Activator	66.20

5600 ACRYLIC URETHANE FLOOR PAINT

- Convenient, high-gloss, water-based coating is ideal for use in mild industrial or commercial setting
- Protects concrete floors from dusting, water damage, staining and mildew
- Paint and go—no measuring or mixing; minimal surface prep
- Excellent coverage over new and previously coated surfaces; for interior/exterior use
- Dries fast—accepts next-day foot traffic; easy brush, spray or roller application
- For use on: Interior/Exterior concrete floors, walkways, decks/patios
- Surface Coverage: 170-270 sq.ft./gal. (4.2-6.6 m²/l)
- Accepted for use in Canadian food processing facilities



KP490

RUST-OLEUM

Model No.	Mfg. No.	Colour	Container Size	Price /Each
KP490	251286	Safety Yellow	1 Gallon	74.30
KP491	251291	Silver Gray	1 Gallon	74.30
KP492	251293	Silver Gray	5 Gallons	368.00

5500 ACRYLIC DUSTPROOFER FLOOR SEALER

- Water-based coating seals concrete and prevents dusting in mild industrial or commercial settings
- Seals bare concrete or provides a protective top coat; makes maintenance easy; low-gloss finish
- Excellent coverage over new and previously coated surfaces; for interior/exterior use
- For use on: Floor coating for warehouses, walkways, over strained and painted concrete, retail/commercial
- Size: 1 Gal.
- Accepted for use in Canadian food processing facilities



KP486

Model No. KP493

Mfg. No. 251282

Price/Each \$54.40

RUST-OLEUM

EASYLEAR™ EPOXY MAINTENANCE FLOOR COATING

- High-gloss finish applies easily to bare or coated concrete
- Excellent resistance to abrasion and chemicals; easy to maintain
- For mild to moderate industrial or commercial environments; interior/exterior use
- Convenient, ready-to-mix kit - includes clear base and activator
- Size: 1 Gal.
- Colour: Clear

Model No. KP494
Mfg. No. 456673
Price/Each \$172.00

RUST-OLEUM



TURBOKRETE® CONCRETE REPAIR & ADHESIVE

- Excellent for bridging horizontal or vertical cracks, even under water
- Twice as strong as concrete
- Works on concrete, masonry, brick, steel and more
- For indoor or outdoor use
- Size: 9 oz.



RUST-OLEUM

Model No.	Mfg. No.	Description	Price /Each
KP497	257395	Light Gray	56.20
KP498	251293	Replacement Static Mixer - 3/Pack	15.90
AF183	261292	Heavy-Duty 9 oz. Caulking Gun	52.40

FLOOR COATING ANTI-SKID ADDITIVE

- Give your epoxy floor as much or as little slip resistance as you'd like
- This specially refined aggregate consists of tiny off-white granules that create extra traction on an epoxy coating
- Compatible with the following epoxy systems: 6500 System and 6000 System
- Can be added directly to the liquid coating or sprinkled over the final finish
- Easy and convenient — mix one bag into each gallon of coating
- Size: 1 lbs.
- Colour: Off-White

Model No. KP500
Mfg. No. 200504
Price/Each \$6.82

RUST-OLEUM



NEVERWET BASE & TOPCOAT KIT

- Two-step aerosol coating system that creates a moisture repelling barrier
- Dries to a flat haze finish
- Surface coverage: 15-20 sq ft/can



RUST-OLEUM

Model No.	Mfg. No.	Size	Colour	Price /Each
KP511	275918	28 oz.	Clear	34.50
KP512	277248	2 gal.	Clear	613.00

TURBOKRETE® CONCRETE PATCH COMPOUND KIT

- Easily repair deep holes and cracks
- 100%-solids epoxy patch kit is designed for floors exposed to heavy traffic and intermittent chemicals
- Protects against abrasion, impact and most chemicals — no sealer required
- Creates an extremely hard surface — 3-4 times stronger than concrete
- For interior/exterior use on damaged or severely spalled floors, curbs, ramps, etc.
- Odorless
- Easy-mix kit includes base, activator and aggregate
- Colour: Light gray

KP495



RUST-OLEUM

Model No.	Mfg. No.	Size Gallons	Surface Coverage	Price /Each
KP495	253479	2	0.15 cu.ft.	119.00
KP496	5494323	3.5	0.30 cu.ft.	231.00

INSTAPATCH® CONCRETE REPAIR

- Quickly patch and repair damaged concrete floors
- InstaPatch® is a two component, 100% solids polyurea concrete repair compound that cures in 15 minutes or less
- Versatile formula can be poured or trowel applied
- Gray InstaPatch changes from black upon application to gray once fully cured
- Can be applied in temperatures as low as -5°F
- Size: 1 gallon

Model No. KP499
Mfg. No. 276981
Price/Each \$230.00

RUST-OLEUM



FLOOR COATING ALUMINUM ANTI-SLIP ADDITIVE

- Boost the longevity, durability and anti-slip qualities of any concrete coating
- This highly versatile aluminum-oxide additive can improve the performance of any floor coating
- Adds both texture and strength
- Consists of tiny granules—finer than sand
- Easy and convenient — mix in one bag per gallon of coating
- Colour: White

Model No. KP501
Mfg. No. 213898
Price/Each \$20.30

RUST-OLEUM



LEAK SEAL SPRAY

- Rubberized coating seals cracks, fills small holes and provides firm-but-flexible protection against moisture and rust
- Great for gutters, roofs, flashing, ductwork, PVC, masonry, concrete and more
- Paintable finish
- Surface Coverage: 8 sq ft/can



RUST-OLEUM

Model No.	Mfg. No.	Size	Colour	Price /Each
KP513	266784A	20 oz.	Black	21.00
KP514	267453	20 oz.	Clear	21.00

PAINT & PAINTING SUPPLIES

EMPTY PAINT CANS

- Available in metal or high density plastic



Model No.	Description	Type	Price /Each
KP119	1 gallon w/lid	Metal	5.47
KP120	1 litre w/lid	Metal	2.77
KP121	1/2 litre w/lid	Metal	2.55

PAINT BRUSHES

China bristle: Carefully selected for proper stiffness and taper, Chinese hog bristle are best suited for spreading oil-based paints, enamels, stains, shellacs and epoxy coatings.

Nylon/Polyester: Multi-polyester and nylon filament tips provide extra wear and will give excellent service with all paints. All filaments are flagged and tipped for excellent paint pick-up and smooth application.

Polyester: A durable synthetic filament that smoothly spreads latex and oil-based paints equally well. Retains stiffness and flexibility in extreme hot weather conditions and gives fine service, easy to clean out.

Animal Soft Hair: Fine animal hair brushes are essential for laying on exceptionally smooth lacquer, shellac, varnish and enamel finishes.

SELECTED CAMEL HAIR ROUND LETTERING MARKING BRUSHES



SELECTED CAMEL HAIR ROUND LETTERING LACQUERING BRUSHES



RED SABLE FLAT BRISTLE ARTIST BRUSHES



PURE WHITE BRISTLE ROUND MARKING BRUSHES



CAMEL HAIR ROUND MARKING BRUSHES

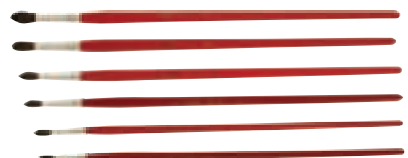

SELECTED OX HAIR ONE STROKE BRUSHES



HEXOMIXERS

THE ONE MIXER FOR ALL MATERIALS

- Hex shaft
- Steel blades



WARNING:

Do not use with lacquers or other flammable liquids (FLASH POINT UNDER 70°F). Sparks from portable electric tool motors might ignite fumes.

IMPORTANT:

Always wear safety goggles while using.

For best results; use a variable speed reversible drill with 400-600 watts minimum.



Model No.	Dia. "	Length"	Drill Size"	Recommended Use	Price /Each
ND399	2.4	16	3/8	1 gal.: paint and other low density materials	10.80
ND400	3.2	16	3/8	2 gal.: paint and other low density materials	11.90
ND401	4.0	24	1/2	3 gal.: paint and low-medium density materials	16.70
ND402	4.8	30	1/2	5 gal.: paint and low-medium density	24.00
ND403	5.6	30	1-2	5-30 gal.: drywall mud and materials	34.00

Model No.	Mfg. No.	Size	Brush Dia. mm	Fill Material	Overall Length"	Handle Type	Price /Each
KP607	12201	1	3	Black Camel	11 1/4	Wood	5.41
KP608	12202	2	4	Black Camel	11 1/4	Wood	6.24
KP609	12203	3	4.5	Black Camel	12	Wood	6.82
KP610	12204	4	5	Black Camel	12	Wood	6.99
KP611	12205	5	5.4	Black Camel	12	Wood	6.04
KP612	12206	6	7	Black Camel	12	Wood	4.93

Model No.	Mfg. No.	Size	Brush Dia. mm	Fill Material	Overall Length"	Handle Type	Price /Each
KP104	10911	1	1.7	Black Camel	7 1/2	Wood	2.72
KP598	10912	2	1.9	Black Camel	7 1/2	Wood	2.51
KP599	10913	3	2.1	Black Camel	7 1/2	Wood	3.02
KP105	10914	4	2.5	Black Camel	7 1/2	Wood	4.09
KP601	10915	5	3	Black Camel	7 1/2	Wood	3.79
KP602	10916	6	3.5	Black Camel	7 1/2	Wood	3.72
KP603	10917	7	4	Black Camel	7 3/4	Wood	5.14
KP604	10918	8	4.7	Black Camel	7 3/4	Wood	4.30
KP605	109110	10	5.7	Black Camel	8	Wood	3.11
KP606	109112	12	7.3	Black Camel	8 3/4	Wood	4.56

Model No.	Mfg. No.	Size	Brush Dia. mm	Fill Material	Overall Length"	Handle Type	Price /Each
KP592	0RS	0	3	Red Sable	10	Wood	4.08
KP593	4RS	4	6	Red Sable	10 3/4	Wood	5.59
KP594	6RS	6	7	Red Sable	11 1/8	Wood	7.41
KP595	10RS	10	8	Red Sable	11 1/2	Wood	12.00
KP596	12RS	12	11	Red Sable	11 1/2	Wood	12.80

Model No.	Mfg. No.	Size	Brush Dia. "	Fill Material	Trim Length"	Handle Type	Price /Each
KP189	74030	1	9/64	White Bristle	11/16	Wood	2.49
KP190	74031	2	5/32	White Bristle	3/4	Wood	3.00
KP191	74032	3	3/16	White Bristle	7/8	Wood	2.98
KP192	74033	4	7/32	White Bristle	1	Wood	3.28
KP193	74034	5	1/4	White Bristle	1 1/16	Wood	3.62
KP194	74035	6	9/32	White Bristle	1 1/8	Wood	3.76

Model No.	Mfg. No.	Size	Brush Dia. "	Fill Material	Trim Length"	Handle Type	Price /Each
KP195	74001	1	9/64	Camel Hair	5/8	Wood	6.95
KP196	74002	2	5/32	Camel Hair	3/4	Wood	7.74
KP197	74003	3	3/16	Camel Hair	7/8	Wood	9.31
KP198	74004	4	7/32	Camel Hair	1	Wood	9.84
KP199	74005	5	1/4	Camel Hair	1 1/16	Wood	12.60
KP200	74006	6	9/32	Camel Hair	1 1/8	Wood	15.30

Model No.	Mfg. No.	Overall Width"	Fill Material	Trim Length"	Handle Type	Price /Each
KP202	74040	1/8	Ox Hair	11/16	Wood	6.04
KP203	74041	1/4	Ox Hair	13/16	Wood	7.54
KP204	74042	3/8	Ox Hair	15/16	Wood	9.62
KP205	74043	1/2	Ox Hair	1	Wood	13.80
KP206	74044	3/4	Ox Hair	1 1/4	Wood	20.20

PAINT & PAINTING SUPPLIES

AP100 SERIES PAINT BRUSHES

- Brush Type: 100% black polyester bristles
- Handle: Solid plastic
- Tin-plated ferrule
- Well-suited for latex-based paints



aurora tools

Model No.	Mfg. No.	Width"	Price /Each
KP307	129BP-1	1	1.30
KP308	129BP-2	2	2.25

AP300 SERIES PAINT BRUSHES

- Brush Type: Natural bristles
- Handle: Solid plastic
- Tin-plated ferrule
- Well-suited for oil-based paints



aurora tools

Model No.	Mfg. No.	Width"	Price /Each
KP300	128-1	1	0.85
KP301	128-2	2	1.35
KP302	128-3	3	2.45
KP303	128-4	4	3.55

RUBBERSET® OIL PAINTBRUSHES

GO BULK

- Lowest priced line of bristle brushes, well suited for fibreglass applications, epoxy resins, paint remover and many industrial uses



Rubberset

Model No.	Type	Width"	Price /Each
NA183	Go Bulk	2	1.81
NA184	Go Bulk	3	3.23

INDUSTRIAL GREY BRISTLE PAINT BRUSH

- General purpose bristle brush
- Ideal to apply paint, glue, epoxy and resins
- 100% grey bristle
- Brush shape: Flat straight
- Handle material: Plastic
- Handle colour: Red



CROWN-MEAKINS
Since 1927 / Dupon 1922

Model No.	Size"	Overall Length"	Brush Thickness	Brush Length Out"	Handle Length"	Price /Each
KP527	1	7-3/4	3/8	1-3/4	4-1/2	0.88
KP528	2	8-1/8	7/16	2	4-3/4	1.78
KP529	3	9	1/2	2-1/4	5-1/4	3.37
KP530	4	9-3/4	5/8	2-1/4	6	4.38

AP200 SERIES PAINT BRUSHES

- Brush Type: Pure white bristles
- Handle: Solid plain wood
- Tin-plated ferrule
- Well-suited for oil-based paints



aurora tools

Model No.	Mfg. No.	Width"	Price /Each
KP306	633-1/2	0.5	0.40
KP297	633-1	1	0.50
KP298	633-2	2	0.75
KP299	633-3	3	1.30

AP400 SERIES PAINT BRUSHES

- Brush Type: Foam brush
- Handle: Solid wood
- Disposable
- Well-suited for applying urethane or for touch-up jobs



aurora tools

Model No.	Mfg. No.	Width"	Price /Each
KP335	850-1	1	0.40

FOAM PAINT BRUSH

- High density foam
- Ideal for paints, stains and varnishes
- Ideal for touch ups and crafts
- Handle material: Wood
- Handle colour: Natural - plain wood



CROWN-MEAKINS
Since 1927 / Dupon 1922

Model No.	Brush Diameter"	Thickness"	Brush Length Out"	Handle Length"	Overall Length"	Price /Each
KP535	2	5/8	2-1/4	4	6-1/2	0.55
KP536	4	1/2	2-3/4	4	6-1/5	0.99

ALL PURPOSE POLYESTER PAINT BRUSH

- General purpose polyester brush
- 100% polyester
- Brush shape: Flat straight
- Handle material: Plastic
- Handle colour: Red



CROWN-MEAKINS
Since 1927 / Dupon 1922

Model No.	Size"	Overall Length"	Brush Thickness	Brush Length Out"	Handle Length"	Price /Each
KP523	1	8-1/8	3/8	2"	4-1/2	0.96
KP524	2	8-1/2	7/16	2-1/4	4-3/4	1.51
KP525	3	9-1/2	1/2	2-1/4	5-1/4	2.60
KP526	4	10	11/16	2-3/4	5-1/2	4.38

ALL PURPOSE BLACK BRISTLE PAINT BRUSH

- General purpose bristle brush
- 100% natural black bristle
- Ideal for paints, primers and adhesives
- Brush shape: Flat straight
- Handle material: Plastic
- Handle colour: Blue



CROWN-MEAKINS
Since 1927 / Dupon 1922

Model No.	Size"	Overall Length"	Brush Thickness	Brush Length Out"	Handle Length"	Price /Each
KP531	1	8	3/8	2	4-1/2	1.73
KP532	2	8-1/2	7/16	2-1/4	4-3/4	3.10
KP533	3	9-3/8	1/2	2-1/2	5-1/4	4.93
KP534	4	10	11/16	2-3/4	5-1/2	8.11

PAINT & PAINTING SUPPLIES

PROFESSIONAL BLACK CHINA BRUSHES

- 100% black China bristle
- Wood handle for better grip
- Long lasting brush



Rubberset®

Model No.	Description	Size"	Price /Each
NA202	Flat Sash	2	11.58
ND868	Wall	4	23.08

PROFESSIONAL NYLON/ POLYESTER ANGLE SASH BRUSHES

- A unique blend of satin-edge nylon (Tynex®) and Orel® polyester
- Recommended for both interior and exterior projects
- Can be used with all paints
- The stiffness retention, a property of polyester, makes this tool ideal for working in hot and humid climates



Purdy®
PROFESSIONAL PAINTING TOOLS

Model No.	Description	Size"	Thickness"	Length Out"	Price /Each
KP031	Blue Heron	2 1/2	5/8	2 15/16	24.25
KP032	XL-Club	2	9/16	2 11/16	20.87
KP033	XL-Dale	1	5/16	1 15/16	14.00
KP034	XL-Glide	1 1/2	1/2	2 7/16	16.63
KP036	XL-Glide	2	9/16	2 11/16	20.87
KP035	XL-Glide	2 1/2	5/8	2 15/16	24.85
KP037	XL-Glide	3	5/8	3 3/16	29.83

CHIP BRISTLE PAINT BRUSH

- Economy brush
- Ideal for stains, resins, glue and grease
- Paint type: All paints and coatings
- Handle colour: Natural - plain wood

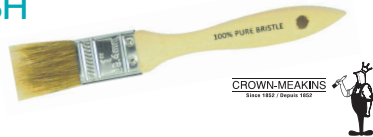

CROWN-MEAKINS
Since 1927 • Depot: 1932

Model No.	Size"	Overall Length"	Brush Thickness	Brush Length Out"	Handle Length"	Price /Each
KP537	1/2	7-1/4	1/4	1-1/2	4-1/4	0.41
KP538	1	7-1/8	5/16	1-1/2	4-1/4	0.47
KP539	2	7-3/4	5/16	1-1/2	4-1/2	0.74
KP540	3	8	3/8	1-1/2	5-1/8	1.15

CLASSIC POLYESTER PAINT BRUSH

- Multi purpose polyester brush
- Ideal for water based paints and stains
- 100% Polyester
- Paint type: Latex/water based paints
- Handle material: Plastic
- Handle colour: Red



CROWN-MEAKINS
Since 1927 • Depot: 1932

Model No.	Size"	Overall Length"	Brush Thickness	Brush Length Out"	Handle Length"	Price /Each
KP541	1	8-3/4	7/16	2-1/4	4-3/4	2.30
KP542	2	9-1/4	9/16	2-3/4	4-7/8	3.29
KP543	3	9-1/2	11/16	2-3/4	5-1/8	3.70
KP544	4	10-1/2	11/16	3	5-1/2	4.19
KP545*	2	11-1/2	9/16	2-1/4	7-1/8	3.29

*Angular brush

CLASSIC BRISTLE PAINT BRUSH

- Multi purpose bristle brush
- Ideal for oil based paints, stains and varnishes
- Ideal for general maintenance
- Handle material: Plastic
- Handle colour: Blue



CROWN-MEAKINS
Since 1927 • Depot: 1932

Model No.	Size"	Overall Length"	Brush Thickness	Brush Length Out"	Handle Length"	Price /Each
KP546	1	8-3/8	7/16	2	4-3/4	3.04
KP547	2	9-1/8	9/16	2-1/2	5	5.21
KP548	3	10	11/16	3	5	8.22
KP549	4	10	11/16	3	5-1/2	11.00

PARTS CLEANING BRUSH

- Ideal for cleaning parts, crevices and hard to reach areas
- Ideal for applying adhesives and lubricants
- Size: 15/16"
- Number size: #8
- Handle material: Plastic
- Handle colour: Natural - plain wood



CROWN-MEAKINS
Since 1927 • Depot: 1932

Model No.	Brush Material	Overall Length"	Brush Length Out"	Handle Length"	Price /Each
KP550	Tampico	10-7/8	2-3/4	6-1/2	5.62
KP551	Crimped Synthetic	10-3/4	2-1/2	6-1/2	5.75

OVAL BRISTLE BRUSH

- Oval sash brush
- Ideal for glue, shellac and machine cleaning
- 100% black bristle
- Tip type: Flat
- Handle material: Plastic
- Handle colour: Natural - plain wood



CROWN-MEAKINS
Since 1927 • Depot: 1932

Model No.	Size"	Number Size	Overall Length"	Brush Length Out"	Handle Length"	Price /Each
KP552	13/32	2	8-7/8	1-3/4	5-1/2	2.63
KP553	21/32	4	9-1/4	1-3/4	5-1/2	3.73
KP554	25/32	6	9-1/2	1-3/4	6-1/4	4.38
KP555	15/16	8	10-5/8	3	6-3/4	5.89
KP556	1-1/16	10	11-3/8	3	6-3/16	8.03

RADIATOR BRISTLE PAINT BRUSH

- Bent radiator brush
- Ideal for painting behind permanent fixtures and hard to reach areas
- 100% bristle
- Handle material: Wood
- Handle colour: Natural - plain wood



CROWN-MEAKINS
Since 1927 • Depot: 1932

Model No.	Size"	Overall Length"	Brush Thickness	Brush Length Out"	Handle Length"	Price /Each
KP557	1-1/2	16-1/4	7/16	2-1/4	12-1/2	7.34
KP558	2	19	3/8	2-1/4	15-1/2	9.62

EXTENSION POLES

- Threaded to fit all standard roller frame handles



Model No.	Description	Size"	Price /Each
NE065	Wood Pole W/Threaded Metal Tip	72	13.33
NE066	Wood Pole W/Threaded Metal Tip	48	9.17

POLYESTER/NYLON BLEND PRO PAINT BRUSH

- Professional blend of polyester and nylon filaments
- Rust resistant steel ferrules, hard wood handles, fine finishing for excellent pick up and release
- Synthetic filaments recommended for latex/water based paints
- Provides high capacity trim control
- Paint type: All paints and coatings
- Handle material: Wood
- Handle colour: Natural - plain wood



KP560

Model No.	Brush Shape	Size"	Overall Length"	Brush Thickness"	Brush Length Out"	Handle Length"	Price /Each
KP559	Angular	1-1/2	11-1/8	7/16	2-1/2	6-1/2	6.85
KP560	Angular	2	11-5/8	9/16	2-3/4	7	10.70
KP561	Angular	2-1/2	12	5/8	3	7	13.00
KP562	Straight	1-1/2	9-5/8	7/16	2-1/2	5-1/4	6.30
KP563	Straight	2	10-1/8	9/16	2-3/4	5-1/2	10.10
KP564	Straight	2-1/2	10-3/4	5/8	3	5-5/8	12.50

CROWN PRO BRISTLE PAINT BRUSH

- Professional bristle brush
- Rust resistant steel ferrules, hard wood handles, fine finishing for excellent pick up and release
- Natural bristle recommended for oil based paints, stains and varnishes
- Provides high capacity trim control
- Paint type: Oil based paints, stains and varnishes
- Handle material: Wood
- Handle colour: Natural - plain wood



KP567

Model No.	Brush Shape	Size"	Overall Length"	Brush Thickness"	Brush Length Out"	Handle Length"	Price /Each
KP565	Angular	1-1/2	11-3/8	7/16	2-1/2	7	8.08
KP566	Angular	2	11-1/2	9/15	2-1/2	7	11.50
KP567	Angular	2-1/2	12-1/2	5/8	2-3/4	7-3/8	15.80
KP568	Straight	2-1/2	10-1/8	5/8	3	6-1/2	12.50

AA BRISTLE STRAIGHT SASH PAINT BRUSH

- Professional bristle brush
- Rust resistant steel ferrules, hard wood handles, fine finishing for excellent pick up and release
- Natural bristle recommended for oil based paints, stains and varnishes
- Long sash handle ideal for comfort and precision
- Paint type: For oil based paints, stains and varnishes
- Handle material: Wood
- Handle colour: Natural - plain wood



KP570

Model No.	Brush Shape	Size"	Overall Length"	Brush Thickness"	Brush Length Out"	Handle Length"	Price /Each
KP569	Straight	2	11-1/4	9/16	3	6-7/8	9.45
KP570	Straight	2-1/2	11-1/2	5/8	3	7-3/8	14.40
KP571	Straight	4	11-1/2	7/8	3-3/4	6	21.40

WOVEN LINT FREE

- Roller cover fabric is tightly woven into the cover backing to provide shed-free results
- Ideal for when the smoothest finish is required
- For latex or oil paint

NA189



Model No.	Size mm	Size inches	NAP (mm)	Description	Price /Each
NA189	240	9 1/2	6	Smooth	5.10
NA190	240	9 1/2	10	Smooth or Light Textured	5.67
NA191	240	9 1/2	13	Semi-Smooth	6.06



MULTI-USE SLEEVES

- Polyester fibre
- For latex or oil paint



NA194

Model No.	Size mm	Size inches	NAP (mm)	Description	Price /Each
NA193	240	9 1/2	6	Smooth	3.67
NA194	240	9 1/2	10	Semi-Smooth	4.17



MOBLEND SLEEVES

- For latex or oil paint



ND897

Model No.	Size mm	Size inches	NAP (mm)	Description	Price /Each
ND897	190	7 1/2	5	Smooth	4.81
ND898	240	9 1/2	5	Smooth	5.88



ONE COAT SLEEVES

- Phenolic core
- For latex or oil paint



ND342

Model No.	Size mm	Size inches	NAP (mm)	Description	Price /Each
ND342	190	7 1/2	6	Very Smooth	3.98
ND899	190	7 1/2	10	Smooth	4.08
NI554	190	7 1/2	13	Semi-Smooth	4.37
ND900	240	9 1/2	6	Very Smooth	5.10
ND901	240	9 1/2	10	Smooth	5.19
ND902	240	9 1/2	13	Semi-Smooth	5.19
NA192	240	9 1/2	25	Rough	5.96



FOAM SLEEVES

- Foam roller covers provide a smooth, lint-free finish
- Available in both smooth and a slit foam for textured surfaces

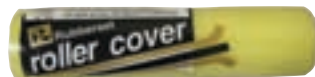

KP083

Model No.	Size mm	Size inches	NAP (mm)	Description	Price /Each
KP083	240	9 1/2	10	Foam Gloss or Semi-Smooth Service	6.06
KP215	240	9 1/2	19	Slit Foam Hi Pile Rough Surface	6.40



PROFESSIONAL AA SYNTHETIC PAINT ROLLER COVER

- Professional high density polyester knit
- For use with all paints
- Cover material: Synthetic blend knit
- Core material: PVC

KP574



Model No.	Dia. "	Length mm (Inches)	NAP mm	For Surface	Price /Each
KP572	1-1/2	240 (9-1/2)	5	Smooth	3.95
KP573	1-1/2	240 (9-1/2)	25	Rough	4.69
KP574	1-1/2	240 (9-1/2)	10	Semi-Smooth	4.44
KP575	1-1/2	240 (9-1/2)	13	Semi-Smooth	4.44
KP576	1-1/2	240 (9-1/2)	19	Semi-Rough	4.58
KP577	1-1/2	240 (9-1/2)	30	Rough	5.07

PAINT & PAINTING SUPPLIES

PROFESSIONAL LINT FREE PAINT ROLLER COVER

- Professional woven lint free
- For use with all paints
- Cover material: Synthetic woven
- Core material: PVC

KP579



Model No.	Dia.™	Length mm (Inches)	NAP mm	For Surface	Price /Each
KP578	1-1/2	240 (9-1/2)	6	Smooth	3.89
KP579	1-1/2	240 (9-1/2)	10	Smooth/Semi-Smooth	4.14
KP580	1-1/2	240 (9-1/2)	13	Smooth/Semi-Smooth	4.38

ROLLER FRAMES

- Wire gauge construction
- Plastic Handle

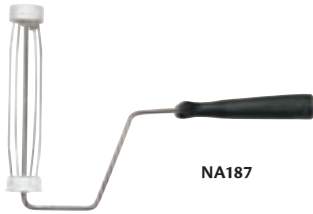

NA187



Model No.	Size		Description	Price /Each
	mm	Inches		
NA185	190	7 1/2	Light Duty 4-Wire Gauge	3.90
NA187	240	9 1/2	Light Duty 5-Wire Gauge	4.23
NA206	240	9 1/2	Heavy Duty 5-Wire Gauge	5.67
NA207	240	9 1/2	Super Pro 5-Wire Gauge	9.29

MINI TRIM ROLLER PAINT COVER

- Trim rollers ideal for touch up and trim work
- For use with all paints
- Cover material: Synthetic knit
- Core material: Plastic

KP581



Model No.	Dia.™	Length mm (Inches)	NAP mm	For Surface	Price /Each
KP581	1-1/2	75 (3)	6	Smooth	1.23
KP582	1-1/2	75 (3)	10	Smooth/Semi-Smooth	1.32
KP583	1-1/2	100 (4)	10	Smooth/Semi-Smooth	1.75

MINI MOBLEND TRIM PAINT ROLLER COVER

- Moblend specialty roller
- For use with all paints
- Cover material: Moblend
- Core material: PVC



Model No.	Dia.™	Length mm (Inches)	NAP mm	For Surface	Price /Each
KP584	1-1/2	100 (4)	5	Smooth	2.60

MINI ROLLER SLEEVES & FRAMES

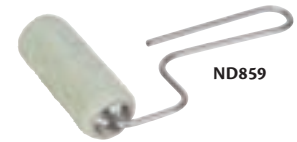

ND859



Model No.	Size		NAP (mm)	Description	Price /Each
	mm	Inches			
ND859	75	3	5	Moblend	3.87
YC637	75	3	5	Polyhide	4.81
NE424	75	3	11	Polyhide	4.81
ND861	110	4 1/2	5	Moblend	6.65
KP216	110	4 1/2	13	Polyhide	6.08

PAINT TRAYS & SETS

TYPE A

General - These deep wall, rust-resistant metal trays and plastic trays have adder grip type legs.

TYPE B

Professional - These trays are of heavy-duty rust resistant metal. They have sturdy metal legs for use with ladders.



Model No.	Type	Description	Price /Each
NE096	A	Plastic Tray, Deep Well, 9 1/2", 4 Litre Capacity	5.90
NA196	A	Metal Tray For 9 1/2" Rollers	6.06
NA208	B	Metal Tray, 9 1/2", 2 Litre Capacity	8.04
NI523		Plastic Tray Liner for NA208	2.13
NA209	B	Metal Tray, 9 1/2", 4 Litre Capacity	15.88
NA205		Plastic Tray Liner for NA209	3.10

PROFESSIONAL PAINTER'S MASKING TAPE/WEATHERABLE

- High quality green coarse crepe paper coated with synthetic rubber
- Excellent UV resistance
- Can be left in place up to 8 days
- Premium masking performance on glass, trim, walls and fresh paint (within 24 hours)
- Secure adhesion, resistant to humidity, stain and paint bleed through
- Conformability and clean removal
- Tensile strength: 19 lbs. (25 mm)



Model No.	Width	Length (m)	Price /Each
PC520	18 mm (3/4")	55	5.22
PC521	24 mm (1")	55	6.80
PC522	36 mm (1 1/2")	55	10.20
PC523	48 mm (2")	55	13.60

PAINTBRUSH & ROLLER CLEANING TOOL

- 3-in-1 cleaning tool
- Removes floating filaments before painting
- Cleans paintbrushes and roller covers
- Removes excess paint from roller covers
- Colour: Yellow

Model No. KP376
Price/Each \$14.00



PAINT MITT

- Polyester blend
- For use with all paints



Model No. KP585
Price/Each \$7.95



PROFESSIONAL PAINTER'S MASKING TAPE

- Quality blue fine-paper crepe-backed painter's tape
- Can be exposed to direct sunlight and high humidity levels for up to 14 days
- Provides very clean paint lines and removes easily, will not leave any residue
- Premium masking performance on glass, trim, walls and fresh paint (within 24 hours)
- Tensile strength: 23 in-lbs.



Model No.	Width	Length (m)	Price /Each
PD082	18 mm (3/4")	54.8	4.96
PD083	24 mm (1")	54.8	7.00
PD084	36 mm (1 1/2")	54.8	11.00
PD085	48 mm (2")	54.8	13.30

ROLLER COVERS

- For use with all paints
- Core material: Plastic
- 2/pack



Model No.	Description	Length mm (Inches)	Diameter"	NAP mm	For Surface	Price /Each
KP590	Micro Fibre Perlon Rollers	100 (4)	3/4	10	Rough/Semi-Smooth/Smooth/Very Rough	3.75
KP591	Micro High Density Foam	100 (4)	3/4	10	Rough/Semi-Smooth/Smooth/Very Rough	4.25

MINI PAINT ROLLER FRAME

- Threaded handle allows for easy replacement and use of various handle lengths
- For 100 mm (4") roller cover
- Handle length: 5-3/4"
- Frame material: Metal - Zinc Plated
- Handle material: Plastic

Model No.	Overall Length"	Price /Each
KP586	16	3.43
KP587	10	3.01

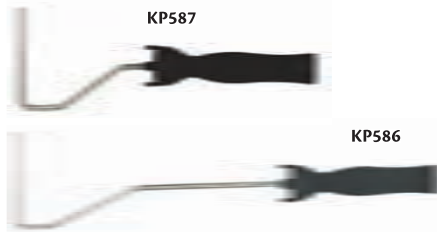

POWER PAINTER® HANDHELD SPRAYERS

- Optimus Dual Tip Technology creates a vacuum effect between tips which draws more paint particles into a single spray pattern with less overspray
- Offers even paint distribution creating a consistent coverage
- Wider spray pattern covers more area in a single pass
- Rotatable nozzle allows up/down painting as well as side-to-side
- Ultra durable tungsten carbide spray tip ensures longer life
- Ideal for thin to thick bodied including unthinned latex
- Includes: carrying case, 6-ft suction set, spare atomizer valve, cleaning brush, lubricating oil, Quick flush adapter



Model No.	Mfg. No.	GPH (Gal per Hour)	Reservoir	Electronic Speed Control	Price /Each
KP291	0525000	5.4	1 Quart	-	196.00
KP292	0525027C	6.6	1.5 Quart	2-Speed Pattern Control	242.00

TWIN STROKE™ PISTON PUMP HIGH PERFORMANCE ELECTRIC AIRLESS SPRAY SYSTEMS

- Delivers even paint flow on both up and down strokes for a powerful and smooth operation
- All units feature a Quickflow™ pusher valves to allow for quick and easy priming every time
- **ND957** is mounted on a rugged and durable stand with carrying handle, while **NI446**, **NI433** and **ND958** are mounted on a Space-Saver telescoping handle cart
- **NI433** includes a ToolMate™ tool box



Model No.	Mfg. No.	Motor HP	Tips	GPM (Gallon per Minute)	Included Spray Gun	Price /Each
ND957	0523012	1/2	Supports a 0.015" Tip	0.25	GX-05 Spray Gun w/ Swivel	736.00
NI446	0523013	5/8	Supports a 0.017" Tip	0.32	GX-07 Metal Spray Gun w/ Filter	980.00
NI433	0523014	3/4	Supports a 0.019" Tip	0.35	GX-07 Metal Spray Gun w/ Filter	1185.00

SOFTSPRAY HVLP CONVERSION GUNS

Converts standard high pressure (1.5 HP and larger) air compressor into a SoftSpray HVLP spray system.

- Three-spray pattern click-in-air cap
- Two-stage trigger
- Stainless needle and nozzle
- Super fine atomization
- NBC non-bleeder gun
- 1 quart cup
- PTE (product transfer efficiency) 89%

Model No. NI448
Price/Each \$368.00



43-PC. SPRAY GUN KITS

PROFESSIONAL QUALITY, INDUSTRIAL STYLE WITH TRADITIONAL FIT & FEEL

Kit includes the following:

- 1 - Siphon feed spray paint gun and 33.8-oz. cup
- 1 - Siphon feed detail spray gun and 6.8-oz. cup
- 1 - Fine head detail air brush
- 1 - Air brush vinyl air hose
- 2 - Paint jars for air brush (1 with siphon tube)
- 1 - Aerosol propellant can adaptor/regulator
- 1 - 1/4" female adaptor for air brush
- 1 - 25' x 1/4" recoil air hose
- 1 - Air blower with hook
- 12-pc. assorted couplers
- 15 - Disposable paint filters
- 5-pc. spray gun cleaning kit
- 1 - Teflon® tape
- 1 - Wrench

Model No. THZ749
Price/Each \$99.20



PAINT & PAINTING SUPPLIES

PAINT PUTTY KNIVES & WALL SCRAPERS

FLEXIBLE PUTTY KNIVES

- For patching small holes and cracks



Model No.	Blade Description	Size"	Handle Description	Price /Each
TK912	Stainless Steel	1 1/4	Polypropylene	8.14
NP310	High-Carbon Steel	1 1/4	Ergo-Grip™	8.32
NP308	High-Carbon Steel	2	Ergo-Grip™	9.07

STIFF PUTTY KNIVES

- For scraping and chipping out old putty



FLEXIBLE WALL SCRAPERS

- For applying drywall compounds

STIFF WALL SCRAPERS

- For scraping old putty, paint, varnish, etc.

Model No.	Blade Description	Size"	Handle Description	Price /Each
NP316	Stainless Steel	1 1/4	Polypropylene	8.14
TK789	Brass	1 1/4	Ergo-Grip™	15.40
NP311	High-Carbon Steel	1 1/4	Ergo-Grip™	8.32
TK790	Brass	2	Ergo-Grip™	17.60
NP337	High-Carbon Steel	2	Ergo-Grip™	9.07

STIFF PUTTY KNIVES

NP316	Stainless Steel	1 1/4	Polypropylene	8.14
TK789	Brass	1 1/4	Ergo-Grip™	15.40
NP311	High-Carbon Steel	1 1/4	Ergo-Grip™	8.32
TK790	Brass	2	Ergo-Grip™	17.60
NP337	High-Carbon Steel	2	Ergo-Grip™	9.07

FLEXIBLE WALL SCRAPERS

NP300	High-Carbon Steel	3	Ergo-Grip™	10.60
-------	-------------------	---	------------	-------

STIFF WALL SCRAPERS

NP301	High-Carbon Steel	3	Ergo-Grip™	10.60
TQ032	Brass	3	Ergo-Grip™	20.00

FLEXIBLE TAPING KNIVES

- For taping drywall joints and applying drywall compounds



Model No.	Blade Description	Size"	Handle Description	Price /Each
TK914	Stainless Steel	4	Polypropylene	14.30
NP280	High-Carbon Steel	4	Ergo-Grip™	14.50
NP276	High-Carbon Steel	5	Ergo-Grip™	15.30
TK916	Stainless Steel	6	Polypropylene	20.10
NP270	High-Carbon Steel	6	Ergo-Grip™	16.60

COMBINATION 6-IN-1 TOOLS

- Cleans paint rollers, cleans out cracks, opens paint cans, scrapes, sets nails, applies dry wall compounds and spackling



NP290

COMBINATION 9-IN-1 TOOLS

- Cleans paint rollers, cleans out cracks, opens or closes paint cans, spreads putty, scrapes concave or convex surfaces, sets or pulls nails



NT067

COMBINATION 11-IN-1 TOOLS

- Sets drywall screws, opens bottles, cleans rollers, opens paint cans, spreads compound, scrapes, closes paint cans, scrapes concave surfaces, scrapes convex surfaces, pulls nails, cleans out cracks

Model No.	Blade Description	Size"	Handle Description	Price /Each
6-IN-1				
NP290	High-Carbon Steel	2 3/8	Ergo-Grip™	13.10
9-IN-1				
NT067	Stiff High Carbon Steel Blade	-	Ergo-Grip™	14.60
11-IN-1				
KP217	Stiff High Carbon Steel Blade	-	Ergo-Grip™	16.70



SEALING SPATULA

- Ideal for spreading or removing sealant and adhesives
- Manufactured with fiberglass reinforced plastic
- Exceptional durability
- Flexible tips
- Sold in packs of 5 spatulas in a clear plastic tube

Model No. TLV164

Price/Each \$42.45

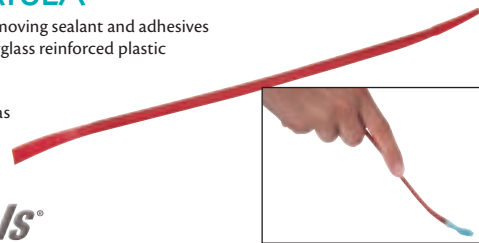

aurora tools®

SCRAPERS

RETRACTABLE RAZOR SCRAPERS

- For scraping and cleaning windows and various surfaces
- Positive locking system
- Metal body
- Replaceable single-edge razor blade

Model No. TK897

Price/Each \$2.62



- For scraping and cleaning windows and various surfaces
- Positive lock system
- Plastic body
- Replaceable single-edge razor blade

Model No. TK895

Price/Each \$1.94



RAZOR SCRAPER BLADES

- Single-edge razor blades
- High-carbon steel, precision ground for long-lasting sharpness



Model No.	Description	Thickness"	Price /Each
TK896	Single-Edge Blades, Pack of 5	0.009	1.59
TK786	Single-Edge Blades, Pack of 100	0.009	16.40
TK787	Single-Edge Blades, Pack of 100	0.012	17.40

RAZOR SCRAPERS

- For scraping and cleaning windows and various surfaces
- Metal body
- Replaceable single-edge razor blade

Model No. TK894

Price/Each \$2.30



ERGONOMIC RAZOR SCRAPERS

- Scrapes and cleans glass, tiles and other smooth surfaces
- Ergo-Grip™ razor scraper with ergonomic rubberized contour
- Maximizes gripping effort and comfort
- Unique system facilitating blade change

Model No. NP323

Price/Each \$5.01



TK928



TK927



PLASTIC HANDLE WOOD SCRAPERS

Model No.	Replacement Blades 20/pck.	Handle Length"	Blade Size"	Uses	Price /Each
TK923	TK924	5 7/8	1	For Scraping Paint and Varnish	4.68
TK925	TK926	7 5/8	1 3/4	For Scraping Paint and Varnish	5.67
TK928	TK929	8 1/2	2 1/2	For Smoothing Wood Surfaces	6.36
TK927	TK929	14	2 1/2	For Smoothing Wood Surfaces	7.97

HEAVY-DUTY FLOOR SCRAPERS

- Foam grip handle
- Reinforced cast metal head maximizing strength
- Ideal to remove carpet, linoleum and other material from walls, floors or wood
- Replacement blades are made of high carbon steel and have two chisel and two square edges per blade

KP218

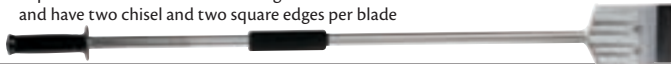

Model No.	Description	Price /Each
KP218	48" Heavy-Duty Floor Scraper	58.10
KP219	12" Heavy-Duty Floor Scraper	39.70
KP220	4" x 4" Replacement Blade For KP218 and KP219	11.30
KP221	6" x 4" Replacement Blade For KP218 and KP219	14.90

WALLBOARD SAWS

- For cutting drywall materials
- Utility saw with 6" heavy-duty steel blade
- Hardwood handle

Model No. TK793
Price/Each \$7.21



Richard

ERGO-GRIP™ WALLBOARD SAWS

- Rubberized Cushion ergonomic handle
- Curve of the handle allows maximum traction
- Guard keeps hand from slipping
- Cuts wallboard, PVC pipes and wood
- High quality, heavy-duty 6" steel blade

Model No. NT074
Price/Each \$14.60



Richard

EXTRA STRONG ERGO-GRIP™ WALLBOARD SAWS

- Cuts wallboard, PVC pipes, wood and other heavy-duty materials
- High quality steel blade is hardened, tempered and ground for more resistance
- Sharp cross teeth ensure fast powerful cut
- Cuts 50% faster than a conventional saw

Model No. NP335
Price/Each \$23.50



Richard

FINISHING TROWELS

- High-carbon spring steel



TK869

TK885

Model No.	Description	Size"	Price /Each
TK868	Cement	14 x 4	15.60
TK869	Cement	16 x 4	16.20
TK885	Drywall	10 x 4	14.20
TK886	Drywall	11 x 4 1/2	14.40
TK887	Drywall	12 x 4	14.70

HAND SANDERS & SANDING BLOCKS



TK856

TK781

NP279

Richard

Model No.	Size"	Description	Application	Price /Each
TK856	4 x 2 3/8	Polypropylene Handle Sanding Block	For Sanding Flat, Curved and Beveled Surfaces	4.59
TK781	5 x 2 3/4	Comfortable Hard Rubber Body Sanding Block	For Sanding Curved or Irregular Shapes	6.57
NP279	9 x 3 1/4	Ergo-Grip Drywall Handsander w/Easy Clamp System	For Hand Sanding of Drywall	16.20

ADHESIVE SPREADERS, CS-PRO SERIES

- For applying adhesive (follow adhesive manufacturer's recommendation for tool notch size and style)
- Blade surface is embossed with ridges for strength
- Cold-rolled satin-finished steel blades
- 3" blades already inserted in painted birch handle



TK861

TK866

TK858

Richard

Model No.	Spreader Description	Tooth Size"	Tooth Dimensions"	Price /Each
TK858	V Notch	3	1/16 x 3/64 x 13/64	3.11
NP326	V Notch	3	3/16 x 1/8 x 1/8	3.11
TK861	V Notch	6	1/32 x 1/64 x 15/64	2.54
TK860	V Notch	6	1/16 x 3/64 x 13/64	2.54
TK862	V Notch	6	3/16 x 1/8 x 1/8	2.54
TK866	V Notch	9	1/32 x 1/64 x 15/64	2.65
TK865	V Notch	9	1/16 x 3/64 x 13/64	2.65
TK867	V Notch	9	3/16 x 1/8 x 1/8	2.65

DRYWALL KNIVES

- For applying and feathering drywall compound

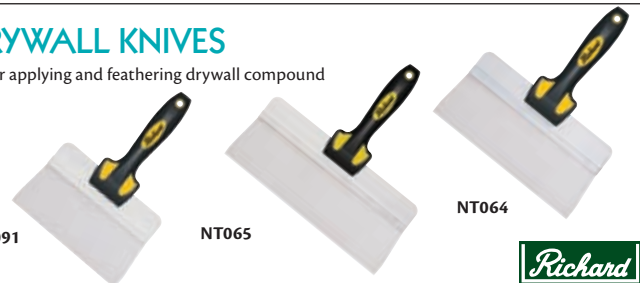

NT091

NT065

NT064

Richard

Model No.	Blade	Size"	Handle Description	Price /Each
TK900	Steel	6	Polypropylene	9.89
TK901	Steel	8	Polypropylene	10.80
NT091	Stainless Steel	8	Ergo-Grip™	14.40
TK898	Steel	10	Polypropylene	11.70
NT064	Stainless Steel	10	Ergo-Grip™	15.30
NT065	Stainless Steel	12	Ergo-Grip™	16.20

ALUMINUM HAWKS

- For carrying and holding compounds while applying to surfaces
- Foam callus preventor hugs the curves of the hand
- The hollow handle is designed to rest on scaffolding rods



NT070

Richard

Model No.	Description	Size"	Price /Each
NT070	Square	10	27.40
NT071	Square	13	32.61

SPONGE SANDERS WITH CLAWS

- Unique universal joint design prevents sponge from flipping
- Four open claw system for easy sanding sponge installation without damaging the sponge
- Aluminum body for professional use
- Female acme thread fits any standard pole
- 7 1/2" x 3 3/8"
- Ideal for drywall compound, wood and other materials
- Comes complete with one KP226 sanding sponge

Model No. KP222
Price/Each \$24.30

REPLACEMENT SANDING SPONGES

- Resistant, last longer than sandpaper
- Reusable, rinse clean with water
- Versatile, can be used wet or dry
- Rectangular sponges are ideal for sanding large surfaces
- Corner sponge is available in fine grit, is rigid to produce smooth, tight corners, flexible to sand slightly imperfect corners and eliminates gouging produced by the edges of regular sanders
- 8 7/8" x 4 3/4"

Richard

Model No.	Description	Dimensions"	Grit	Price /Each
KP223	4-Sided Drywall Sanding Sponge	8 7/8 x 4 3/4	Fine	6.00
KP224	4-Sided Drywall Sanding Sponge	8 7/8 x 4 3/4	Medium	6.00
KP225	2-Sided Drywall Sanding Sponge	8 7/8 x 4 3/4	Fine	5.52
KP226	2-Sided Drywall Sanding Sponge	8 7/8 x 4 3/4	Medium	5.52
KP227	3-Sided Triangular Corner Sanding Sponge	2 1/2 x 2 1/2 x 8 3/4	Fine	7.21



ZIPWALL® BARRIER SYSTEMS

- Provides a quick and easy dust barrier without the use of tape or a ladder, without damaging the surface
- Lightweight and easy to use
- Extendable poles can be used on vaulted or angled ceilings
- GripDisks™ eliminate slippage on hard floors
- Can be used with plastic up to 8 mm thick or with ZipWall® zippers
- Foam Railstm models feature a cross bar with a soft spongy edge that press firmly against the ceiling creating a tight seal



ZIPWALL®

Model No.	Mfg. No.	Includes	Length of Pole	Price /Each
NT099	SLP2	2 Aluminum Poles and Parts	4'7" to 12'	250.00
NT100	KT20	2 Aluminum Poles and Parts	5'2" to 20'	411.00
KP613	4PL-KIT	4 Aluminum Poles and Parts, 2 Foam Rails, 2 Standard Zippers and a Carrying Bag	4'7" to 12'	545.00
KP135	SLP6	6 Aluminum Poles and Parts	4'7" to 12'	637.00
KP589	SLP4	4 Aluminum Poles and Parts, 2 Standard Zippers and a Carry Bag	4'7" to 12'	466.00



ACCESSORIES

Model No.	Mfg. No.	Includes	Price /Each
KP136	FR2	Two 5' Foam Rails Cross Bar and 2 T-Clips Adaptor	89.50
KP140	SDKP	Six 3" Foam Cross Bar, 6 T-Clips Adaptor and a Carrying Bag	357.00
NT101	AZ2	2 ZipWall® Standard Zippers	22.60
THZ766	CB1	Carrying Bag	109.00
KP147	NSP2	2/Pack Non-Skid Replacement Plate	28.20
KP329	TPH1	Replacement Head, Plate and Tether	36.60
KP148	GD2	Grip Disk™ for Holding Bottom of Poles Securely Over Smooth Surfaces	12.20
KP139	SC2	2 Side Clamps	87.90

PAINTER'S DROP SHEETS

- Contractor quality, 100% canvas cotton construction
- Protects floor and furniture from paint mishaps
- Available in wthree sizes to fit most rooms
- Bordered edges
- 8 oz



Model No.	Size'	Price /Each
KP040	4 x 12	12.20
KP041	10 x 11	24.40
KP042	12 x 15	40.40

PLASTIC SHEETS

PAINTER-CONTRACTOR GRADE

- Ideal for covering walls, furniture and large surfaces
- High density, lighter and tougher than regular plastic
- 9' x 400' roll in a convenient dispenser box, allows you to use only what you need, while protecting roll from dust and damage
- Resists bleed-through
- Easy to tape to a wall



Model No.	Size'	Price /Each
NI594	9 x 400	42.50

PLASTIC DROP SHEETS

- Available in three grades for a wide variety of applications
- Economy grade is ideal as a dust cover, furniture cover, chest liner and outdoor table cover
- Regular grade can be used as a drop sheet for paint as well as an outside rain cover
- Industrial grade recommended for use on construction sites as weather protection, window repair and equipment cover
- Size: 10' x 25'



Model No.	Description	Price /Each
NI622	Economy	8.75
NI623	Premium	14.50
NI624	Industrial	21.50

TACK CLOTHS

- Cleans any wood, metal or plaster surface of dust, dirt and sanding residue, ready for a smooth blemish free finish
- Size: 18" x 36"
- 24/case

Model No. JB988
Price/Each \$27.10



COTTON WIPING CLOTHS

- Cleans spills, dusting, polishing, waxing and paint cleanup
- Soft enough for your car and other delicate surfaces
- Made from 100% all new cotton material
- Pack of 8 rags

Model No. KP043
Price/Each \$6.26



COTTON PAINTER'S HOODS

- 100% bleached white cotton
- Made from breathable, non-itchy cotton
- One size fits all

Model No. KP334
Price/Each \$2.23



SANDBLASTING & FUME EXTRACTORS

SANDBLAST MEDIA ABRASIVES

- All abrasives are sold in 50-lb. bags
- Other grades of abrasives also available
- Steel grit and steel bead also available

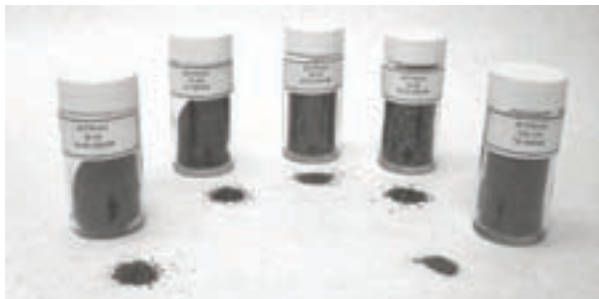

GLASS BEADS

A popular media used primarily for dimensionally sensitive applications where tolerance and finish are your main concerns. Perfect for re-moving medium to light contamination without causing dimensional change, over stressing, imbedding or pitting. Used widely by automotive rebuilders, die and mold makers in the plating and aerospace industries.

Model No.	US Screen	Application	Price/Each
TG392	20-30	Coarse	56.50
TG393	30-40	Coarse	56.50
TG394	40-50	Coarse	56.50
TG398	50-70	Med. Coarse	56.50
TG399	70-80	Medium	56.50
TG400	70-100	Medium	56.50
TG401	80-120	Fine	56.50
TG402	100-170	Fine	56.50
TG403	140-230	Fine	56.50
BZ738	170-325	Fine	56.50

ALUMINUM OXIDE

Highly aggressive abrasive. Ideal for applications where tough contamination is encountered and surface removal of 0.0005" to 0.08" is acceptable. Resulting finish is ideal for painting, plating and coating. Grit sizes range from #16 (coarse) to #220 (fine).

Model No.	Grit	Application	Price/Each
TG404	16	Coarse	115.00
NP845	20	Coarse	115.00
TG405	24	Coarse	115.00
BZ740	30	Coarse	113.00
BZ739	36	Coarse	115.00
TG406	46	Med. Coarse	116.00
BZ741	54	Med. Coarse	115.00
TG407	60	Med. Coarse	116.00
TG408	70	Medium	116.00
TG409	80	Medium	115.00
NP846	90	Medium	116.00
TG410	100	Med. Fine	116.00
NP847	120	Med. Fine	115.00
TG411	150	Med. Fine	116.00
TG412	180	Fine	126.00
TG413	220	Fine	126.00

JETMAG (SYNTHETIC OLIVINE PYROXENE SAND)

The only true substitute to sand (silica), JetMag offers excellent sanding quality and is cost/performance ratio is highly competitive. It allows faster cleaning and reduces consumption, therefore it offers greater productivity in enclosed work places. Because of its chemical and mineral composition, JetMag is a non-toxic material and environment friendly. Less than 1% free silica.

Model No.	Description	Application	Price/Each
NP848	16-60	16 Mesh	19.95
NP849	30-60	24 Mesh	19.95
NP850	35-70	40 Mesh	19.95

PRESSURE ABRASIVE SANDBLASTERS

- Heavy-duty all steel construction
- Loading abrasive is made simple using the concave funnel top of the tank
- Safety pressure relief valve
- 1/2" (I.D.) x 8' abrasive feed hose
- Durable wheels and handle allow for easy mobility and flexible operation
- Includes media gun, 4 interchangeable nozzles (2, 2.5, 3 & 3.5 mm), water separator filter, protective blast hood and teflon tape
- 5 HP air compressor is recommended for optimal performance



Model No.	Mfg. No.	Tank Cap. gal.	Operating Pressure Range PSI	Required Compressor Output CFM	Max. Amount of Abrasive lbs.	Dimensions L' x W' x H"	Weight lbs.	Price /Each
TMA003	KSB-10	10	65-120	6-25	40	14 x 17 x 33 1/4	48	256.00
TMA004	KSB-20	20	65-120	6-25	80	15 3/4 x 20 x 35	56	301.00

SANDBLAST CABINETS

- Filtered fluorescent light
- Gun comes with different sized nozzles for different usage
- 2 rubber gauntlet gloves mounted in front



Model No.	BV745	BC894
Mfg. No.	KSB-110N-9	KSB-350
Fluorescent light	110 V	110 V
Maximum operating pressure	100 PSI	116 PSI
Required compressor output	5 CFM/PFM @ 80 PSI	15-25 CFM/PFM @ 40-80 PSI
Max. amount of abrasives	10 lbs.	35 lbs.
Cabinet dimensions	23" x 19" x 12" - 15"	37" x 26 3/4" x 17 1/2" - 25 1/2"
Dimensions (L x W x H)	23" x 19" x 19"	37" x 26 3/4" x 59"
Weight	36 lbs.	176 lbs.
Price/Each	\$226.00	\$812.00

ACCESSORIES

Model No.	Mfg. No.	Description	Price /Each
TEX180	KM-035	Replacement sandblast gun	60.10
TJZ760	KM-036	Replacement ceramic nozzle (4/Pkg.)	25.50
EA564	KM-097	Adhesive window protector for BV745 (5-pc. Kit)	26.90
EA565	KM-098	Adhesive window protector for BC894 (5-pc. Kit)	26.90



LIGHT INDUSTRIAL - ECONOBLAST SERIES SUCTION CABINETS

The Econoblast compact blast cleaning cabinet is offered in various convenient dimensions. These blast-cleaning cabinets are the most economical and versatile models available on the market. Built for occasional work, they are ideal for cleaning, finishing, deburring and etching. If you need an abrasive blasting cabinet and have a limited budget, the Econoblast will perform most tasks. for cleaning, deburring, stripping and deflashing.



SPECIFICATIONS:

- Dust bag standard - ventilation 400 CFM
- 1/3 HP, 3450 RPM, 115 V TEFC motor
- Natural latex gloves with nylon gauntlets
- Single door opening
- Window: 13" x 21" with plastic protector
- Halogen 250 W flood light
- Ceramic 5/16" nozzle, 5/32" air jet
- Trigger blasting control
- Will operate with a 5 HP industrial compressor
- 14-gauge expanded steel deck
- Convenient quick flush rubber plug
- Sturdy 13 gauge steel construction
- CSA approved
- Capacity: 300 lbs.
- Made in Canada
- Optional dust collector

Model No.	Dimensions"	Filtration Sq.Ft.	Price/Each
TG414	26 x 36	13	3501.00
NP839	26 x 36	50	5184.00
TG415	28 x 44	13	3803.00
NP840	28 x 44	50	5565.00
TG417	36 x 48	13	4356.00
NP842	36 x 48"	50	6146.00

SEMI-INDUSTRIAL - ECAB SERIES SUCTION CABINETS

The semi-industrial line of blast finishing cabinets is a mid-level line designed to deliver the same dependability and performance as the industrial units, but at a more economical price. Whatever the application, all that is necessary is an air compressor producing a minimum of 22 CFM, and several pounds of sandblasting media (glass beads, aluminum oxide, etc.). Use the semi-industrial Ecab cabinets for medium duty cleaning, etching, deburring, finishing, trimming, etc.



SPECIFICATIONS:

- Dust bag standard - Ventilation 400 CFM
- 1/2 HP, 3450 RPM, 115 V TEFC Motor
- Natural latex gloves with nylon gauntlets
- 13" x 21" window with plastic protector
- Single door opening
- 2 x 100 W halogen bulbs
- Ceramic 5/16" nozzle, 5/32" (34 CFM) air jet standard
- Foot pedal blasting control
- Regulator and gauge air control
- Adjustable louver air vent
- 1/8" perforated steel screen drawer
- Convenient rubber plug for quick flushing of recycler
- 14 gauge steel construction
- 3 1/2" diameter return hose
- Abrasive recycler included
- CSA approved
- Capacity: 300 lbs.
- Made in Canada

Model No.	Dimensions"	Filtration Sq.Ft.	Price/Each
TG419	26 x 36	13	4956.00
NP828	26 x 36	50	6709.00
NP829	28 x 36	100	8410.00
TG421	36 x 48	50	6058.00
NP833	36 x 48	100	8986.00

DUST COLLECTORS & DUST BAGS – SUCTION OR PRESSURE TYPE CABINETS

- Models **TG422** and **NP766** dust bags are standard dust filtration and reclamation system used with the Econoblast and Ecab series blast cleaning cabinets
- Model **TG418** dust collector is designed for medium duty blast cleaning operations
- Models **TG423** and **NP827** dust collectors are designed for heavy-duty applications and are the most efficient for preventing dust from escaping into the work environment and contaminating machines and work surfaces

Model No.	Description	Filtration Sq.Ft.	Motor HP	Fan CFM	Price /Each
TG418	Medium Duty Dust Collector	50	0.5	400	1932.00
TG423	Heavy-Duty Dust Collector	100	1	600	3445.00
NP827	Heavy-Duty Dust Collector	230	2	1200	5619.00
TG422	Dust Bag	13	0.33	400	105.00
NP766	Dust Bag	30	1	600	197.00



SANDBLASTING & FUME EXTRACTORS

80-LB. CAPACITY PORTABLE BLASTER

- Ideal for light maintenance jobs on machinery and road equipment
- Requires minimum 5 HP air compressor to operate
- CSA approved, made in Canada
- Capacity: 1.0 cu.ft
- Includes: Blast hose 8' long (3.04 m) and 1/2" I.D. (12.7 mm), with fittings. Ceramic nozzle, 1/8" (3.1 mm) orifice. Protective washers for nozzle and fittings. **BZ689** protective hood with replacement visor. **BZ685** remote control system.

Model No. TJZ979
Piping: 1/2"
Total height: 39"
Tank diameter: 12"
Capacity: 80 lbs.
Weight: 45 lbs.
Price/Each \$570.00



346® PORTABLE PRESSURE BLASTER

- Tank capacity of 4.1 cubic feet, 18" diameter
- Standard pressure release dead man control systems, for greater safety
- Abrasive metering valves will assure precise and easy control flow of abrasive
- Standard pneumatic dead man remote control system
- Convex top for built-in filling funnel
- Removable plunger with no threads
- Durable sealing plunger
- Extra low profile
- Large hand hole for easy access to inside of tank
- Lifting eyes
- Heavy duty piping
- Conical bottom
- Stabilizing support frame which eliminates wheel fatigue and pot tip over
- Large hard rubber wheels
- Air pressure gauge
- Water separator

TMA028 includes: Pneumatic sandblaster, 50' sandblasting hose, one tungsten carbide nozzle, Radex air purifier, 50' of air hose to feed air between air purifier and protective hood and Nova 2000 air supplied protective kit

TMA026 includes: 50' sandblasting hose and one tungsten carbide nozzle

TMA027 includes: Radex air purifier, 50' of air hose to feed air between air purifier and protective hood and Nova 2000 air supplied protective kit



Model No.	Mfg. No.	Description	Weight	Price/Each
TMA021	646101	Pneumatic Sandblaster Only	225 lbs.	3687.00
TMA026	734400	Portable Pressure Blaster Kit #1 (Sandblaster Not Included)	275 lbs.	867.00
TMA027	735000	Portable Pressure Blaster Kit #2	300 lbs.	1456.00
TMA028	-	Portable Pressure Blaster Complete Kit	500 lbs.	6003.00



NP768



BZ715



TG425

BZ692

NP776

NP773

BZ694

ACCESSORIES FOR SUCTION CABINETS

BLAST GUNS & NOZZLES

Model No.	Description	Dimensions"	For cabinets	Price/Each
TG424	With Ceramic Nozzle	5/16	Econo	319.00
TG425	With Ceramic Nozzle	5/16	Ecab, M	289.00
NP823	With Boron Carbide Nozzle	5/16	Ecab, M	431.00
BZ715	Gun Body Only	-	Econo	252.00
BZ719	Gun Body Only	-	Ecab, M	135.00

ACCESSORIES FOR SUCTION & PRESSURE CABINETS

Model No.	Description	Dimensions	Price/Each
NP768	Cabinet gloves – Leather Sleeves	30" x 8"	212.00
BZ690	Cabinet gloves – Nylon Sleeves	30" x 8"	80.40
BZ720	Replacement Laminated Window	22" x 14"	88.50
BZ681	Replacement Plastic Shields	23 3/4" x 18 3/4"	5.93
BZ682	Replacement Plastic Shields	20 3/4" x 12 7/8"	7.67
BZ684	Plastic Pail White	23 Liters	24.50
NP806	Blast Hose	I.D. 1/2", O.D. 1 3/16"	57.80
NP807	Blast Hose	I.D. 3/4", O.D. 1 1/2"	157.00
BZ699	Blast Hose Kit	NP806 and BZ700	125.00
BZ700	Quick Connect Stem Coupling for NP806	-	4.85
NP809	Quick Connect Stem Coupling for NP807	-	12.30

NOZZLES FOR BLASTING GUNS

STRAIGHT BARREL W/ TAPERED BODY –
 7/8" OD DIAMETER AT BASE, 1 1/4" LENGTH

Model No.	Description	Dimensions"	For cabinets	Price/Each
BZ691	Ceramic Nozzle	1/4	Econo	27.00
BZ692	Ceramic Nozzle	5/16	Econo	26.60
NP769	Tungsten Carbide Nozzle	1/4	Econo	128.00

STRAIGHT BARREL W/ TAPERED BODY –
 1 1/8" OD DIAMETER AT BASE, 1 3/8" LENGTH

Model No.	Description	Dimensions"	For cabinets	Price/Each
NP770	Ceramic Nozzle	1/4	Ecab, M	15.20
NP771	Ceramic Nozzle	5/16	Ecab, M	15.20
NP776	Ceramic Nozzle	3/8	Ecab, M	15.20
NP772	Ceramic Nozzle	7/16	Ecab, M	15.20
NP773	Tungsten Carbide Nozzle	1/4	Ecab, M	102.00
NP774	Boron Carbide Nozzle	1/4	Ecab, M	145.00
BZ694	Boron Carbide Nozzle	5/16	Ecab, M	145.00
NP775	Boron Carbide Nozzle	7/16	Ecab, M	145.00

SANDBLASTING & FUME EXTRACTORS



MOBILE FILTERS & MOBILE FILTERS ECO

- Mobile mechanical filter for welding fumes, grinding dust, etc
- Compact and flexible
- The extraction arm captures fume and dust at a distance of 30-50 cm (12-20") from the source and within an area of 0.5 m (20") diameter
- Black hood w/optimized airflow and ring handle and built in damper
- Flame proof PVC hose 160 mm (6.5") diameter
- This unit can also be fitted with an activated carbon filter which removes gases from polluted air

CONSTRUCTION:

- Unit made of powder painted steel sheet 16 ga.
- Fan 0,75 kW(1HP), 120 V, 1-phase, 2400 m³/hr (1400 CFM) free-blowing
- The unit filters 1250 m³/hr (700 CFM) through the hood
- Comes standard with 1-prefilter (spark-trap) and 1 washable (99% spun-bound polyester) cartridge filter (P-160)
- Active filter surface 14 m² (150+ ft²)
- Delivered complete with ON/OFF starter, cable, and plug
- Flameproof 6.5' PVC coated fibreglass hose
- **5-year limited warranty**

Model No.	Mfg. No.	Description	Price/Each
BA655	P-150/P-002	Mobile Filter w/2 m Extraction Arm	4473.00
BA656	P-150/P-003	Mobile Filter w/3 m Extraction Arm	4709.00
BA657	P-160	Replacement Filter Cartridge for BA655-BA656 (Cleanable with Compressed Air)	412.00
BA659	P-160-W	Replacement Filter Cartridge for BA655-BA656 (Washable with Soap and Hot Water, Suitable for Oily Smoke)	466.00
EA452	P-535/P-002	"Self Cleaning" Mobile Fume Extractor w/2 m Extraction Arm	4944.00
EA453	P-535/P-003	"Self Cleaning" Mobile Fume Extractor w/3 m Extraction Arm	5297.00
EA454	P-541	"Eco" Replacement Filter Cartridge for EA452-EA453 (Cleanable with Compressed Air)	424.00



MOBILE FUME EXTRACTORS W/SELF CLEANING FILTERS

For direct capture of dust, smoke and fumes. Suitable for the following applications:

- Dry Particulates
- Welding Smoke
- Fumes
- Carbon Dust
- Plastic Dust
- Ceramic Dust
- Woodworking
- Fibreglass
- Textiles
- Rubber Dust
- Grinding Dust
- Powders
- Dry Chemicals
- Composites
- Cotton Dust
- Synthetics

Dirty air enters the cabinet from the hose and is directed vertically downward which results in a 180° turn at the bottom of the unit, causing separation of heavier particles into the removable dust pan. Second stage cartridge filter, traps the remaining particles with up to 99% efficiency.

SPECIFICATIONS:

Construction: 16-gauge steel cabinet finished with 2 part chemical and oil resistant paint. Includes Ultra-Seal® filter mounting system, removable access door to filters and direct drive motor/blower, 6.7' externally self-supporting E-Z Arm™ high flow pickup arm, 8" fixed front and 5" rear swivel casters, power cord, and on-off switch.

Weight: 255 lbs. Shipping weight 400 lbs.

Airflow: 1200 CFM with 1.5 HP motor

Noise: 70 dBA / 73 dBA 1.5 HP

Electrical: 1.5 HP 115/1/60

Filter Seal: Ultra-Seal® with positive sealing filter locking mechanism for all main filters, optional HEPA filter and adsorber modules (when used). Slide tracks shall be used for prefilters only.



Model No.	Mfg. No.	Description	Price /Each
BA710	PCH-1-1.5	Self Cleaning Mobile Filter w/2-m arm	13753.00
BA667	7FR02020	Replacement Filter Cartridge	306.00
BA712	PCH-1-PG-5	0-5" Dial Pressure Gauge	352.00

Note: Other extractors also available

FANS FOR FUME EXTRACTORS

- Powerful, silent, energy efficient fans provide even airflow for the lowest possible power consumption
- Extra bracket required for use with booms (use BA694 for 6.5" boom and EA456 for 8" boom)

Model No.	Mfg. No.	Voltage/ Phases/Amp	Free-Blowing		Nominal (At-The-Hood) CFM	Price /Each
			HP	CFM		
EA263*	P-149-1	115/1/60	1.0	1200	1 @ 700 CFM	1353.00
EA562	P-149	115/1/60	1.5	1200	1 @ 700 CFM	1412.00
BA683	P-152-1	115/1/60	1.5	1400	1 @ 1000 CFM	1647.00
BA689	P-152-2	208-230-460/3/60	2.0	1700	2 @ 600 CFM or 1 @ 900 CFM	1647.00
BA693	P-152-3	575/3/60	2.0	1700	1 @ 600 CFM or 1 @ 900 CFM	1647.00
EA264	P-154-1	208-230-460/3/60	3.0	1800	3 @ 600 CFM or 2 @ 900 CFM	3179.00
EA265	P-154-2	575/3/60	3.0	1800	3 @ 600 CFM or 2 @ 900 CFM	2589.00
EA266	LD-130-1	208-230-460/3/60	5.0	2000	4 @ 600 CFM or 3 @ 900 CFM	5062.00
EA267	LD-130-2	575/3/60	5.0	2000	4 @ 600 CFM or 3 @ 900 CFM	5069.00
EA268	LD-150-1	208-230-460/3/60	7.5	3000	6 @ 600 CFM or 5 @ 900 CFM	6297.00
EA269	LD-150-2	575/3/60	7.5	3000	6 @ 600 CFM or 5 @ 900 CFM	6297.00

*Complete with Plug & Play



FUME EXTRACTOR ARMS

- An extractor arm extracts smoke, dust and gases directly at the source, before the contamination has spread in the premises and been inhaled
- Superior extraction arm and advanced design "Parallelogram" counter balancing system that eliminates the need for continual adjustment of friction joints and allows for an unparalleled ease of movement
- Ideal solution for most "source-capture" applications and specifically recommended for applications requiring an "easy to position" extractor that does not require constant adjustment
- Compact and smooth design, excellent for areas with low ceiling
- **5-year limited warranty**

Flexi construction: Internal supporting mechanism made of mild steel tubing, 3 spring-assisted joints to provide precise counterbalancing of the extractor's inner and outer arm. Comes with a black baked-on enamel steel hood w/ optimized airflow and ring handle, and built in damper and with black baked-on enamel wall bracket. Motor and fan not included.

lev-co

EXTRACTOR ARMS

Description	Flexi I, 6.5" dia Model No.	Mfg. No.	Price /Each	Flexi II, 8" dia Model No.	Mfg. No.	Price /Each
7' (2 m) Extractor Arm w/Wall Bracket	BA660	P-007	1101.00	BA978	P-143	1413.00
10' (3 m) Extractor Arm w/Wall Bracket	BA661	P-008	1295.00	BA979	P-144	1619.00
14' (4 m) Extractor Arm w/Wall Bracket	BA662	P-009	1531.00	BA980	P-145	1854.00
17' (5 m) Extractor Arm w/Wall Bracket	BA663	P-010	1707.00	BA985	P-146	2031.00



H MAX F SERIES COMBOS

- Boom and extractor arm combos
- Combos specially developed for welding, mixing of chemicals, grinding, and other applications when you need to reach over long distances
- Hoses are made of flame proof PVC with internal steel spiral
- Comes with Super-Flex® horizontal arm with ball bearing, extractor arm, hood with ring handle and built-in damper, wall bracket, hose and hood
- Fan and motor not included

H MAX F SERIES COMBOS

Description	Model No.	Price /Each
20' Boom & Extractor Arm Combo	BA675	2689.00
28' Boom & Extractor Arm Combo	BA680	3169.00

WALL FLEX & WALL FLEX ECO

NEW SELF-CLEANING UNIT NOW AVAILABLE

- Used to "at-Source" capture and filter a variety of airborne contaminants such as fumes, dust and gases
- Recognized as an excellent solution for the specific demands filtering source captured contaminants, the wall flex comes complete with a cleanable or self-cleaning filter and fan

CONSTRUCTION:

- Unit made of powder coated 12-14-16 ga. sheet steel
- Fan 0.75 kW (1HP), 120 V, 1-phase, 2400 m³/hr (1450 CFM) free-blowing
- Capacity: 1250 m³/hr (730 CFM) (With extraction arm)
- Standard with 1-prefilter and 1 washable 99% main filter (99.5% @ .5 micrometers)
- Complete with ON/OFF motor starter and overload protection
- 3.5 m (12') cable and plug
- Reverse Pulse-Jet filter cleaning units include:
 - Spark-proof impeller
 - Motor out of the air stream
 - Removable dust drawer
- **5-year limited warranty**
- **Always refer to owners manual before operating this type of equipment**

FEATURES & BENEFITS:

- "All Steel design" (not including hose) - No plastic to bend, melt or otherwise lose shape & deform
- Compact wall mount design - Saves on floor space
- Washable or self-cleaning filters - Avoid high cost replacement filters
- Available w/pulse jet filter cleaning system - Save on time required to clean the filters

lev-co

Arm not included



Model No.	Mfg No.	Description	Price /Each
BA697	P-026/P-149/115V/1PH	Wall Mounted Filter w/115/1/60; 1.5 HP Fan	2699.00
BA657	P-160	Replacement Filter Cartridge for BA697, BA698 and BA699 (Cleanable with compressed air)	412.00
BA659	P-160-W	Replacement Filter Cartridge for BA697, BA698 and BA699 (Washable with soap and hot water... Suitable for oily smoke)	466.00
EA454	P-541	Replacement Filter Cartridge for EA462, EA463 and EA464 (Cleanable With Compressed Air)	424.00

SANDBLASTING & FUME EXTRACTORS



PORTA-FLEX PORTABLE WELDING FUME EXTRACTORS WITH BUILT IN FILTER

- Suitable for welding in confined spaces or difficult to reach locations
- Perfect for service and repair work
- Efficient filtration
- The filter cartridge has long life and efficient filtration
- It is easy to change when it is full
- Uniquely easy to bring with you
- Porta-Flex has a weight of just 15kg
- It is extremely easy to carry with you as you roll the hose around the handle and fix the magnet nozzle to the outside of the filter box
- Two versions available
- Both come with flexible hose 2.5 m and filter cartridge is included with both



EA515, PORTA-FLEX 200 (1KW) 160M³/H

- EA515 comes standard with EA517 400 mm Porta-Flex nozzle
- Designed for use with the smokeless welding torches and lighter duty applications for collection of dust and smoke at the source
- Polluted air is drawn away and filtered through a 3-stage filtration system
- 28 lbs.

EA516, PORTA-FLEX 200 AUTO (1KW) 160M³/H & AUTOMATIC START/STOP .

- Collects dust and smoke at the source
- Polluted air is drawn away and filtered through a 3-stage filtration system
- The dual powered fan system assures consistent and effective performance
- The side selection of filter combinations allow the unit to be used in a variety of applications
- Comes complete with an "AUTO-START" control which turns on the collector when the welder strikes the arc.
- 28 lbs.

Model No.	Mfg. No.	Description	Price/Each
EA515	P-610	Porta-Flex 200 1-phase/1kW/115V/60Hz, 650(W)x250(D)x450mm(H)	2354.00
EA516	P-614	Porta-Flex 200 Auto 1-phase/1kW/115V/60Hz with automatic start/stop	3296.00
EA517	P-615	400mm Porta-Flex Nozzle with Magnetic Base	224.00
EA518	P-616	300mm Porta-Flex Nozzle with Magnetic Base	224.00
EA519	P-617	200mm Porta-Flex Nozzle with Magnetic Base	224.00
EA520	P-618	80mm Porta-Flex Nozzle with Magnetic Base	224.00
EA521	P-619	Replacement Main Filter for the Porta-Flex	409.00
EA522	P-620	Replacement HEPA Filter for the Porta-Flex	573.00



POWER CAT[®] PORTABLE BLOWERS

- Provides the extra power to tackle tough, industrial jobs
- Unique portable blower can be used for ventilating, cooling and heating the work space
- Removes fumes and smoke created during welding through addition of accessories
- Choice of 300 CFM model blower, or variable 1120/877 CFM unit
- Fitted with a duplex receptacle featuring 25', heavy-duty grounded extension cord
- 120 Volt/60 Hz motor
- Accessories sold separately



EA090

Model No.	Mfg No.	Blower	Lamp	Receptacle	Price /Each
EA090	A300	300 CFM	40 Watts	Duplex, Grounded	258.00
EA091	1200XL	High Speed – 1120 CFM Low Speed – 877 CFM	N/A	Duplex, Grounded Weather-Resistant	492.00

Model No.	Mfg. No.	Description	Price /Each
-----------	----------	-------------	-------------

FOR MODEL EA090

EA092	300DA	Duct accessory. 10' x 5" flexible duct with exhaust adaptor. Use to extend EA094 in 10' increments.	176.00
EA093	300EXT	Extension accessory. 10' x 6" flexible duct with connecting sleeve and clamp. Use to extend EA092 and EA094 in 10' increments.	158.00
EA094	300IA	Intake accessory. 10' x 6" flexible duct with quick-mount fittings at both ends.	227.00
EA095	300FE	Welding Fume Exhaust Nozzle. Clamps to EA094 to direct intake of welding fumes.	116.00

FOR MODEL EA091

EA096	1200EA	Extension accessory. Easily attaches to connect EA098 to unit.	144.00
EA097	1200IA	Intake Adaptor. Quick-mount fitting to attach duct to unit.	58.60
EA098	1200FD	Flexible Duct. 10' x 8" duct to be used with either EA096 or EA097.	236.00
EA099	1200DC	Duct Coupling. Clamp-on connector for additional EA098 ducts.	40.50
EA100	1200FE	Welding Fume Exhaust Nozzle. Clamps to EA098 for extraction of welding fumes.	112.00

ACCESSORIES FOR MODEL EA090



EA093

EA094

EA095

EA092

ACCESSORIES FOR MODEL EA091



EA100

EA097

EA099

EA098 & EA096



WELDING EQUIPMENT & SUPPLIES

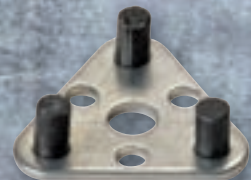

GAS WELDING OUTFITS & ACCESSORIES



WELDING & CUTTING OUTFITS

All Harris Classic outfits come complete with tool bag and include the following torch features: Solid forged head, brazed triangular tube design, ease-on cutting valve and protected torch union



Solid Forged Head



Brazed Triangular Tube Design



Ease-On Cutting Valve



Protected Torch Union

STEELWORKER® CLASSIC WITH TOOL BAG

- Cuts to 5" and welds to 1/2" with larger tips
- Includes:**
 - Torch handle (85)
 - Mixer(D-85)
 - Cutting attachment (72-3)
 - Cutting tip (6290-1AC)
 - Welding tip (23A90-5)
 - Single stage 0-100 PSIG oxygen regulator
 - Single stage 0-15 PSIG fuel gas regulator
 - 20' x 3/16" hose
 - Goggles
 - Striker

Model No. TTU521
Mfg. No. 4403224
Price/Each \$659.00



TTU521



PIPELINER® CLASSIC WITH TOOL BAG

- Cuts to 6" and welds to 1" with larger tips
- Includes:**
 - Torch handle (43-2)
 - Mixer (E-43)
 - Cutting attachment (73-3)
 - Cutting tip (6290-1AC)
 - Welding tip (23A90-5)
 - Single stage 0-125 PSIG oxygen regulator
 - Single stage 0-15 PSIG fuel gas regulator
 - 20' x 1/4" hose
 - Goggles
 - Striker

Model No. TTU520
Mfg. No. 4403235
Price/Each \$936.00



TTU520



IRONWORKER® MEDIUM-DUTY WITH TOOL BAG

- Cuts to 5" and welds to 1/2" with larger tips
- Includes:**
 - Torch handle (85)
 - Mixer (D-85)
 - Cutting attachment (72-3)
 - Cutting tip (6290-1AC)
 - Welding tip (23A90-5)
 - Single stage 0-100 PSIG oxygen regulator
 - Single stage 0-15 PSIG fuel gas regulator
 - 20' x 1/4" hose
 - Goggles
 - Striker

Model No. TTV225
Mfg. No. 4400366
Price/Each \$561.00



TTV225



PORT-A-TORCH® OUTFITS

- All outfit components are industrial grade for professional use
- Cutting attachments feature solid forged heads, triangular stainless steel tubes with brazed connections, solid brass forged levers and a lock ring that secures torch nut in place
- Torch handles feature silver-brazed, twin-tube construction and easily replaceable Flashguard® check valves
- Regulators equipped with an encapsulated Teflon® seat for safety and extended service life

- Includes:** Welding tip (23A90-3), Fuel gas regulator (601-15-200), Oxygen regulator (601-80-540), 3/16" x 12' hose, 20 cu. ft. oxygen cylinder, 10 cu. ft. "MC" acetylene cylinder, cylinder wrench, goggles, striker and instruction manual
- Stored in a heavy-duty, weather-proof and flame retardant tool bag

Model No.	Mfg. No.	Description	Torch Handle	Cutting Attachment	Mixer	Cutting Tip	Price /Each
TTU624	4403211	Classic Style	85	72-3	D-85	6290-1AC	930.00
TTU625	4403214	V-Series Style	V100C	V1350	V-W1	V-V3-101	930.00



GAS WELDING OUTFITS & ACCESSORIES

LIGHT/MEDIUM DUTY TOTE-A-TORCH OUTFITS

- For use in general repair, maintenance and HVAC applications
- Can weld up to 3/16" and cut up to 1/2"
- Rear entry regulators provide better balance
- Acetylene regulator has an MC CGA200 inlet connection; oxygen regulator has standard CGA540 connection

- **Includes:**
 - Torch handle with check valve
 - Cutting attachment
 - Oxygen/acetylene regulators with 2" double-scale gauges
 - Cutting tip
 - Welding nozzle
 - 12.5' twin hose
 - Goggles
 - Striker
 - Tank wrench
 - Cylinders
 - Polypropylene carrier

Model No. TTT892
Mfg. No. 72-PTC
Price/Each \$827.00



PROWELD
 by GENTEC

SILVER MEDIUM-DUTY WELDING & CUTTING OUTFITS

- Can weld up to 1/4" and cut up to 1/2"
- Ideal general purpose kit for construction, facility maintenance, petroleum and chemical industries
- Victor® Cutskill® compatible
- Comes in environmentally-friendly packaging for easy transportation

- **Includes:**
 - Torch handle with check valve
 - Cutting attachment
 - Oxygen/acetylene regulators with 2" double-scale gauges
 - Cutting tip #0
 - Welding nozzle #2
 - T-Grade 17.5' twin hose
 - Goggles
 - Striker

Model No. TTV021
Mfg. No. 7120
Price/Each \$392.00



GENTEC
 GENSTAR TECHNOLOGIES

TOTE-A-TORCH OUTFITS

- Light-to-medium duty portable outfit
- Welds up to 3/16" and cuts up to 1/2"
- Rear entry regulators for better balance
- Acetylene regulator has an "MC" (CGA 200) inlet connection; oxygen regulator has standard CGA 540 connection
- Victor® portable torch or Super Range® compatible

- **Includes:**
 - Torch handle (142T)
 - Cutting attachment (142C)
 - Regulators (210X-80/210Y-15)
 - Cutting tip (172C-0)
 - Welding nozzle (172W-1)
 - 12.5' twin hoses
 - Goggles
 - Striker
 - Plastic carrier
 - One "MC" acetylene cylinder
 - One "R" oxygen cylinder

Model No. 331-1070
Mfg. No. 12-PTC
Price/Each \$890.00



GENTEC
 GENSTAR TECHNOLOGIES

SILVER HEAVY-DUTY WELDING & CUTTING OUTFITS

- Can weld up to 1/2" and cut up to 3/4"
- Ideal for industrial and commercial applications
- Victor® Cutskill® compatible
- Comes in environmentally-friendly packaging for easy transportation

- **Includes:**
 - Torch handle with check valve
 - Cutting attachment
 - Oxygen/acetylene regulators with 2 1/2" double-scale gauges
 - Cutting tip #1
 - Welding nozzle #2
 - T-Grade 17.5' twin hose
 - Goggles
 - Striker

Model No. TTV022
Mfg. No. 7130
Price/Each \$524.00



GENTEC
 GENSTAR TECHNOLOGIES

OXY-FUEL THE SMALL TORCH™ KITS

- Designed for plumbing, HVAC, refrigeration and jewelry manufacturing and repair
- Braze and solder material from the tiniest up to 1/8" thick steel
- Melts up to 3 oz silver
- Provides stable and precise concentrated feather flame up to 6000°F for various material such as metals, ceramics and glass
- Acetylene gas service

- **Includes:**
 - Torch handle (10ST)
 - Tips (10STP2 - 6)
 - Hose
 - Oxy/fuel regulators (where applicable)



333-102201204



333-102201209

GENTEC
 GENSTAR TECHNOLOGIES

Afraid of Heights...

We've Got You Covered!



KLETON

Canada's Leading Material Handling Supplier

Model No.	Mfg. No.	Description	Price /Each
333-102201204	GKSTA06	Kit w/o Regulators	186.00
333-102201209	GKSTA16	Kit with Oxy/Fuel Regulators	452.00

OFFICE PRODUCTS

INSTRUMENTS, SCALES & ELECTRICAL

SHIPPING & PACKAGING

TOOLS & EQUIPMENT

WELDING & METALWORKING

SAFETY EQUIPMENT & SUPPLIES

JANITORIAL & MAINTENANCE

MATERIAL HANDLING & STORAGE

GAS WELDING OUTFITS & ACCESSORIES

AIR-ACETYLENE OUTFITS

- Choice of Quick-Connect (Swirl Flame), or Screw-Connect (Soft Flame) type tips
- KASL Series features quickly-connect auto-ignite tips with swirl flame which is ignited with a push of a button
- B tank connection
- Includes:**
Regulator (101 Y-BA)
Torch handle
Tip Hose (HGA-012A)

333-102205701



Model No.	Mfg. No.	Soft Solder"	Silver Braze"	Handle	Torch Tip	Price /Each
SWIRL FLAME, QUICK-CONNECT STYLE OUTFITS						
333-102205601	KA5BSP	1 1/2	3/4	66QT-RA	6Q-5TA	308.00
SOFT FLAME, SCREW-CONNECT STYLE OUTFITS						
333-102205701	KASF4BSP	1	n/a	77ST-RA	7S-4SA	186.00
SWIRL FLAME, QUICK-CONNECT STYLE OUTFITS W/AUTO-IGNITE TIPS						
333-102205608	KASL5BSP	1 1/2	3/4	66QT-RA	6Q-5TASL	308.00

AIR-ACETYLENE FEATHER FLAME® TORCH KITS

- Screw-in style
- Feather brush flame
- Interchangeable screw-in tips
- Heavy-duty torch
- UL listed brass regulator
- Includes:**
12' hose
Handle
Lighter
Wrench



330-1663

Model No.	Mfg. No.	Tip No.	Reg. FTG	Price/Each
330-1663	KA-1H	BA-3	"B" Cylinder	247.00
330-1669	KA-2H	BA-3	"MC" Cylinder	247.00

AIR-ACETYLENE TARGET® TORCH KITS

- Snap-in style
- Hot turbine flame
- Interchangeable snap-in style tips
- Heavy-duty torch
- UL listed brass regulator
- For professional soldering and brazing applications
- Includes:**
Quick disconnect handle
12' hose
Tip(s)



330-1777

Model No.	Mfg. No.	Tip No.	Reg. FTG	Price/Each
330-1777	KX-3B	GA-3, GA-11	"B" Cylinder	514.00
330-1780	KX-7B	GA-8	"B" Cylinder	405.00

AIR-ACETYLENE REGULATORS

- Made for rugged use
- Manufactured of solid brass
- 1 1/2" W x 3 5/16" H
- Specially designed conical seat and a neoprene diaphragm
- Inlets have filters to prevent dirt from entering regulator
- "A" hose fitting
3/8 - 24 L.H.
- UL listed

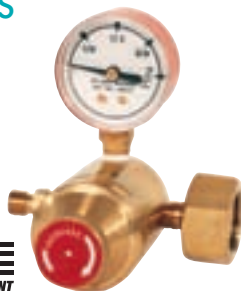

Model No.	Mfg. No.	Connection	Price/Each
330-1423	EA-1G	"B" Cylinder	143.00
330-1426	EA-2G	"MC" Cylinder	143.00

HOTSPOTTER ALL-PURPOSE PROPANE HEAVY-DUTY TORCH KITS

- All-purpose propane flame tool operates off the pressure of a standard propane tank - no regulator required
- 31" handle
- Ideal for a wide variety of all-season maintenance/repair applications
- Burns weeds, repairs asphalt, seals tar, peels paint, removes road markings, melts ice and thaws pipe
- 500 000 BTU rating
- Includes:**
10' neoprene hose
On/off valve
Durable cast iron and steel nozzle
Striker



Model No.	Mfg. No.	Price /Each
312-4904	WB-101	125.00

PROPANE TORCH KITS

- Lightweight and durable steel construction
- Designed for heavy-duty outdoor applications such as weed burning, ice melting, drying/heating, asphalt, tar and road repair
- 500 000 BTU output
- On/Off brass needle and flame adjustable valve
- 10' hose with POL excess flow check valve and B-connection, no regulator required
- Includes:**
Torch
Spark lighter
10' hose



Model No.	Mfg. No.	Price /Each
TTU321	KP-320A	122.00



AUTO-IGNITE HAND TORCHES

- Durable cast iron construction
- High output swirl flame
- Precise flame adjustment
- CGA600 inlet connection
- Use with Propane or MAPP®



Model No.	Mfg. No.	Replacement Tip End	Price /Each
333-9120750400	8Q-44TP	4TPESL	163.00

AIR-ACETYLENE FEATHER FLAME® SCREW-IN TIPS

- Quiet, adjustable flame
- For soft soldering and light brazing



Model No.	Mfg. No.	Tip "	Soft Solder"	Price/Each
330-1054	BA-1	1/16	1/16 - 1/8	33.10
330-1057	BA-2	1/8	1/8 - 1/4	32.80
330-1060	BA-3	3/16	1/4 - 1/2	30.30
330-1066	BA-4	1/4	1/2 - 1	30.30
330-1069	BA-5	5/16	1 - 1 1/2	38.00
330-1072	BA-6	7/16	2 - 4	42.30



GAS WELDING OUTFITS & ACCESSORIES

CLASSIC TORCH HANDLES NO. 43-2

- High capacity combination handle
- Stainless steel head
- Equipped with FlashGuard® check valves
- Capacity: cuts 6", welds to 1"
- 9 1/2" length

Model No. TTT898
Mfg. No. 1401150
Price/Each \$440.00



CLASSIC TORCH HANDLES NO. 85

- Silver brazed twin tube construction for safety and durability
- Equipped with FlashGuard® check valves
- Capacity: cuts 5", welds to 1/2"
- 8 1/2" length

Model No. TTT899
Mfg. No. 1401340
Price/Each \$349.00



CLASSIC CUTTING ATTACHMENTS

- Solid forged head resists abuse and distortion
- Triangular tube design is compact and lightweight with exceptional strength and rigidity
- Brazed connections prevents leaks
- Protected torch union nut protects seals and O-rings from abuse
- Solid forged lever for exceptional strength
- Ease-on cutting oxygen control for smoother starts
- 90° torch head angle

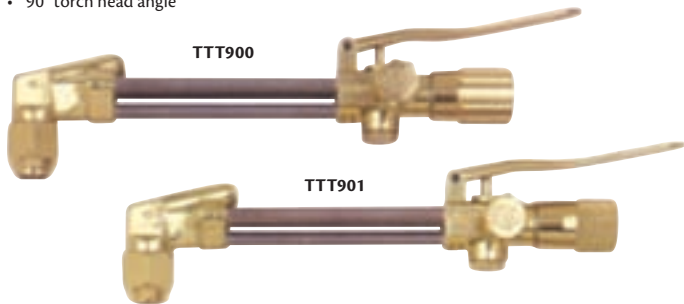

HARRIS® INFERNO® AIR FUEL ACETYLENE KITS & TIPS

- Brazing and soldering without oxygen
- Hottest air fuel tip available
- Compatible with all competitive quick connect air fuel torches
- Results in faster brazing and soldering
- Precision manufactured for the best flame on the market today
- Kit includes: Quick connect handle, regulator (CGA 520), tip (TTU646) and hose
- Every tip made in USA by Harris® to exacting standards

Model No. TTU641
Mfg. No. 4400085
Price/Each \$402.00



TTU641



TTU646



Model No.	Mfg. No.	Uses Torch Head	Price/Each
TTT900	1300340	43-2	515.00
TTT901	1300380	85	506.00

ACETYLENE TIPS

Model No.	Mfg. No.	Tip"	Gas Flow @ 14 PSI SCFH	Soft Solder"	Brazing"	Price /Each
TTU645	1601110	1/4	3.10	Up to 1	Up to 1/2	113.00
TTU646	1601111	5/16	5.80	3/4 - 1 1/2	1/4 - 3/4	134.00
TTU647	1601112	3/8	6.60	1 - 2	1/2 - 1	147.00
TTU648	1601113	7/16	9.80	1 1/4 - 3	7/8 - 1 5/8	156.00

HAND CUTTING TORCHES

- The industry standard by which all other designs are compared!
- Cuts to 12"
- Solid forged head
- Triangular tube design
- Brazed connections
- Equipped with FlashGuard® check valves
- Choice of positive pressure "E" Torches for acetylene and alternate fuels, and low pressure "F" Injector Torches for maximum performance with alternate fuels such as propane, natural gas, MAPP® gas, and propylene

Note: "F" torches are NOT FOR USE with acetylene



TTT905

Model No.	Mfg. No.	Head Angle°	Length"	Price/Each
POSITIVE PRESSURE "E" TORCHES				
TTT902	1003464	70	21	685.00
TTT903	1003440	90	21	685.00
TTT904	1003351	70	36	912.00
TTT905	1003441	90	36	912.00
LOW PRESSURE "F" INJECTOR TORCHES				
TTT906	1003370	70	21	685.00
TTT907	1003470	90	21	685.00
TTT910	1003400	70	36	912.00
TTT911	1003480	90	36	912.00

STRAIGHT CUTTING V242 HAND CUTTING TORCHES

- Victor® compatible medium-duty torch
- Designed for use with all fuel gases
- Cutting capacity: 6"
- Uses Victor® series 1 tips
- Features stainless steel cutting lever, ease on cutting valve, triangular tube design and Flashguard® check valves
- Equal pressure mixer
- UL listed
- Meets CGA E.5 standards

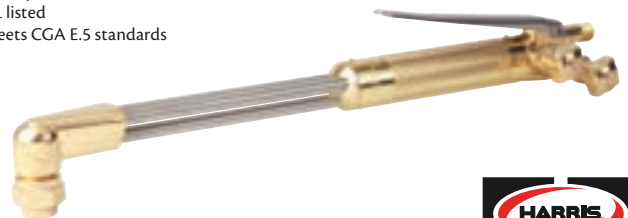

Model No.	Mfg. No.	Head Angle°	Length"	Price /Each
TTV175	1004639	70	18	367.00
TTV176	1004618	90	18	367.00
TTV177	1004637	70	21	367.00
TTV178	1004603	90	21	367.00

GAS WELDING OUTFITS & ACCESSORIES



SINGLE STAGE REGULATORS NO. 25

- One-piece encapsulated seat design with an internal filter and a PTFE Teflon® seat
- Chrome-plated bonnet with forged brass body
- 2" dual scale gauges
- Gauge guards sold separately



Model No.	Mfg. No.	Gas	Max Inlet PSIG	Delivery Pressure Range, PSIG	Delivery Pressure Gauge, PSIG	Supply Pressure Gauge, PSIG	Inlet Connection	Outlet Connection	Price /Each
TTT920	3000380	Acetylene	500	0-15	30	400	CGA510	9/16"-18 LH	249.00
TTT921	3000450	Propane*	500	0-50	60	400	CGA510P	9/16"-18 LH	249.00
TTT922	3000510	Oxygen	3000	0-100	150	4000	CGA540	9/16"-18 RH	249.00
TTT923	3000540	Ar, N ₂ , He	3000	0-100	150	4000	CGA580	9/16"-18 RH	249.00
TTT924	3000550	Industrial Air	3000	0-100	150	4000	CGA590	9/16"-18 RH	249.00
TTT925	3000806	N ₂	3000	0-200	400	4000	CGA580	9/16"-18 RH	303.00

GAUGE GUARDS

TTT926	4300140	Fuel Gas	49.90
TTT927	4300139	Oxygen	49.90

*Regulator designated for propane service can be used with any of the other welding grade liquid petroleum gases. NOT FOR USE WITH ACETYLENE.

152 SERIES - SINGLE STAGE REGULATORS

- Designed for medium-duty gas welding, cutting and heating applications
- Body and housing cap are machined from class "A" brass bar stock
- Self re-seating external safety pressure relief valve on oxygen models
- Stem type seat assembly for more reliable performance
- 2" gauges for easy reading
- 2" diaphragm
- UL listed



Model No.	Mfg. No.	Gas Service	Max Inlet/Delivery Pressure (PSI)	Inlet Gauge	Outlet Gauge	Inlet Connection	Outlet Connection	Price /Each
331-3575	152X-80	Oxygen	3000/4-80	2", 4000 PSI	2", 100 PSI	CGA540	9/16"-18 RH (M)	158.00
331-3585	152Y-15	Acetylene	400/2-15	2", 400 PSI	2", 30 PSI, RL	CGA510	9/16"-18 LH (M)	158.00



153 SERIES - SINGLE STAGE REGULATORS

- Designed for heavy-duty gas welding, cutting and heating applications
- 2 1/2" gauges for easy reading
- 3 1/4" stainless steel diaphragm for accurate pressure delivery
- Delrin cap bushing for smooth adjustments
- Stem type seat assembly for more reliable performance
- Body and housing cap machined from class "A" brass bar stock
- Self re-seating external pressure relief valve on oxygen model
- Sintered bronze inlet filter
- UL listed



Model No.	Mfg. No.	Gas Service	Max Inlet/Delivery Pressure (PSI)	Inlet Gauge	Outlet Gauge	Inlet Connection	Outlet Connection	Price /Each
331-3665	153X-125	Oxygen	3000/5-125	2 1/2", 4000 PSI	2 1/2", 200 PSI	CGA540	9/16"-18 RH (M)	305.00
331-3675	153Y-15	Acetylene	400/2-15	2 1/2", 400 PSI	2 1/2", 30 PSI, RL	CGA510	9/16"-18 LH (M)	305.00



452 SERIES - SINGLE STAGE REGULATORS

- Designed for medium to heavy-duty gas welding, cutting and heating applications; the "Horse" is a Harris® style regulator
- 2 3/4" diaphragm and a Victor® style seat mechanism
- Forged brass body
- Chrome plated housing cap
- Self re-seating external pressure relief valve on oxygen, inert gases and carbon dioxide models
- Sintered bronze inlet filter
- UL listed



Model No.	Mfg. No.	Gas Service	Max Inlet/Delivery Pressure (PSI)	Inlet Gauge	Outlet Gauge	Inlet Connection	Outlet Connection	Price /Each
331-4385	452X-80	Oxygen	3000/4-80	2", 4000 PSI	2", 100 PSI	CGA540	9/16"-18 RH (M)	144.00
331-4380	452X-175	Oxygen	3000/5-175	2", 4000 PSI	2", 300 PSI	CGA540	9/16"-18 RH (M)	144.00
331-4395	452Y-15	Acetylene	400/2-15	2", 400 PSI	2", 30 PSI, RL	CGA510	9/16"-18 LH (M)	144.00
TTT120	452C-175	Carbon Dioxide	3000/5-175	2", 4000 PSI	2", 300 PSI	CGA320	5/8"-18 RH (F)	144.00
331-4285	452C-300	Carbon Dioxide	3000/20-300	2", 4000 PSI	2", 400 PSI	CGA320	5/8"-18 RH (F)	240.00
TTT118	452N-80	Inert Gases*	3000/4-80	2", 4000 PSI	2", 100 PSI	CGA580	5/8"-18 RH (F)	146.00
331-4340	452N-300	Inert Gases*	3000/20-300	2", 4000 PSI	2", 400 PSI	CGA580	5/8"-18 RH (F)	206.00
804-1975	452N-450	Inert Gases*	3000/30-450	2", 4000 PSI	2", 600 PSI	CGA580	5/8"-18 RH (F)	226.00



*Argon, nitrogen, helium

GAS WELDING OUTFITS & ACCESSORIES

153 SERIES – GAUGE PROTECTORS

- Durable metal construction
- Reduces potential damage to pressure gauges
- Easy to install and remove from regulators
- For use with Gentec® 153 Series regulators, interchangeable with other major brands

Note: Gauge protectors are not designed to replace or alleviate the need for proper cylinder storage systems. Cylinders should always be used and stored in conjunction with local and OSHA requirements.



Model No.	Mfg. No.	Description	Price/Each
TTT893	GP31X	Oxygen Gauge Protector	20.90
TTT894	GP31Y	Acetylene Gauge Protector	20.90



TTT893



TTT894

190 SERIES - FLOW GAUGE REGULATORS

- "MIG METER" flow gauge regulators are designed for MIG and TIG applications
- 2" gauges for easy reading
- Accurate measurement of gas flow up to 50 SCFH
- Body machined from class "A" brass bar stock
- Chrome-plated housing cap
- Internal safety pressure relief design
- Plastic adjustment knob for smooth "easy touch" flow settings
- UL listed



Model No.	Mfg. No.	Gas Service	Max Inlet/Delivery Pressure (PSI)	Inlet Gauge	Outlet Gauge	Inlet Connection	Outlet Connection	Price /Each
331-1540	190AR-50	Argon	0-50	2", 4000 PSI	2", 50 SCFH	CGA580	5/8"-18 RH (F), 0.32" Orifice	127.00
331-1575	190CD-45	Carbon Dioxide	0-45	2", 4000 PSI	2", 50 SCFH	CGA320	5/8"-18 RH (F), 0.32" Orifice	127.00



191 SERIES - FLOWMETER REGULATORS

- Designed for MIG and TIG applications
- Provides accurate regulation of gas flow
- Piston type construction
- Body machined from class "A" brass bar stock
- Polycarbonate flow tube and outer cover are impact resistant
- Conforms to CGA E-4 standard for gas pressure regulators



Model No.	Mfg. No.	Gas Service	Flow Capacity (SCFH)	Inlet Gauge	Flowmeter (SCFH)	Inlet Connection	Outlet Connection	Price /Each
331-1610	191AR-60	Argon	50	1 1/2", 4000 PSI	60	CGA580	5/8"-18 RH (M)	159.00
TTT131	191CD-60	Carbon Dioxide	50	1 1/2", 4000 PSI	60	CGA320	5/8"-18 RH (F)	165.00

WITH 6-FOOT HOSE INCLUDED

331-4150	191AR-60-6HSP	Argon	50	1 1/2", 4000 PSI	60	CGA580	5/8"-18 RH (M)	190.00
331-3200	191CD-60-6HSP	Carbon Dioxide	50	1 1/2", 4000 PSI	60	CGA320	5/8"-18 RH (F)	199.00



195 SERIES - "MIG MASTER" FLOWMETER REGULATORS

- Designed for MIG and TIG applications and provide accurate regulation of gas flow
- Provides reliable performance in commercial, industrial and lab applications
- Single stage construction
- 0-60 SCFH argon (Ar) flow, 0-150 SCFH helium (He) flow, 0-60 SCFH carbon dioxide (CO₂) flow
- Polycarbonate flow tube and outer cover are impact resistant for maximum durability and service life
- Flowmeter is backpressure compensated to ensure accurate readings when line restrictions are present
- 2" high-pressure gauge for easy reading
- Body machined from class "A" brass bar stock
- Chrome-plated housing cap
- Internal safety pressure relief design
- Sintered bronze inlet filter
- UL listed



Model No.	Mfg. No.	Gas Service	Outlet Pressure Preset (PSI)	Inlet Gauge	Flowmeter (SCFH)	Inlet Connection	Outlet Connection	Price /Each
331-1638	195AR-60	Argon	50	2", 4000 PSI	60	CGA580	5/8"-18 RH (F)	219.00
331-4166	195AR-60-680	Argon	50	2", 6000 PSI	60	CGA680	5/8"-18 RH (F)	228.00
331-4175	195CD-60	Carbon Dioxide	50	2", 4000 PSI	60	CGA320	5/8"-18 RH (F)	226.00



GAS WELDING OUTFITS & ACCESSORIES

195FM SERIES - FLOWMETERS

- Designed for accurate regulation of gas flow
- Backpressure compensated design insures accurate readings when line restrictions are present
- Polycarbonate flow tube is square shaped for easy reading
- Body machined from class "A" brass bar stock
- Easy adjustment brass knob for "fine-tune" flow settings
- UL listed



Model No.	Mfg. No.	Gas Service	Max Inlet Preset (PSI)	Inlet Connection	Outlet Connection	Flowmeter Flow Range (SCFH)	Price /Each
331-4185	195FM	Argon, Carbon Dioxide	50	1/4" NPT(M)	5/8"-18 RH(F)	0-60 Ar	116.00



198CD ELECTRICALLY HEATED REGULATORS/FLOWMETERS FOR CARBON DIOXIDE

- Designed for applications requiring extremely high gas flow rates
 - Built-in, thermostatically-controlled electric heater keeps the carbon dioxide warm, allowing for continuous duty cycle without freezing
 - 110 VAC/190 W heater is standard
 - 0-60 SCFH flowmeter is backpressure compensated to ensure accurate reading when line restrictions are present
 - Forged brass body and housing cap with sintered bronze inlet filter
- Caution:** Use this regulator only with non-siphoned standard carbon dioxide cylinders



Model No.	Mfg. No.	Gas Service	Max Delivery Pressure (PSI)	Inlet Gauge	Flowmeter (SCFH)	Inlet Connection	Outlet Connection	Price /Each
331-4210	198CD-60	Carbon Dioxide	50 (Preset)	2", 4000 PSI	60	CGA320	5/8"-18 RH(F)	429.00



BRASS PRESSURE GAUGES

- Dual scale
- Lexan™ cover lens
- 1/4" NPT inlet



Model No.	Description	Price /Each
NT616	2" x 100 PSI	9.60
NT617	2" x 200 PSI	9.60
NT618	2" x 30 PSI – Red line	9.60
NT619	2" x 400 PSI	9.60
NT620	2" x 4000 PSI	10.25
NT622	2 1/2" x 200 PSI	10.25
NT623	2 1/2" x 30 PSI – Red line	10.25
NT624	2 1/2" x 400 PSI	10.25
NT625	2 1/2" x 4000 PSI	10.25



STEEL PRESSURE GAUGES

- Dual scale
- Lexan™ cover lens



Model No.	Mfg. No.	Scale Ranges	Entry Type	Price /Each
1 1/2" STEEL CASE, 1/8" NPT INLET				
331-2980	G15-030RL	0-30 PSI – Red Line	Side	12.20
331-2985	G15-100	0-100 PSI	Side	12.20
331-2990	G15-400	0-400 PSI	Side	12.20
331-2995	G15-4000	0-4000 PSI	Side	14.60
331-2445	GR15-4000	0-4000 PSI	Rear	14.60
2" STEEL CASE, 1/4" NPT INLET				
331-2405	G20-050CF	0-50 SCFH	Side	12.50



PROPANE REGULATORS

- High pressure industrial/commercial regulator
- Vapour service with portable torches or construction heaters
- Rated for approximately 2 000 000 BTU
- Includes fittings: 0 – 60 PSIG
- **Hose sold separately**

Model No. TTV219
Price/Each \$55.50



PROPANE HOSES

- For use with propane regulator
- Quality flexible hose
- 350 PSI rating
- CGA approved

Model No.	Mfg. No.	Length'	Price /Each
722-1070	HP-6	6	22.40
722-1010	HP-10	10	32.40
722-1030	HP-20	20	59.60
722-1040	HP-25	25	70.10



4 IN 1 CUTTING ATTACHMENT

CIRCLES-STRAIGHT CUTS-BEVELS-REGULAR LINE CUTS

- Converts any standard torch into an accurate convenient multi-use tool
- Cut perfect circles up to 25" in diameter
- Make precision straight edge and end cuts
- Adjustable guide wheels provide a steady base making it easy to follow irregular patterns and odd cuts

Model No. TTV221
Price/Each \$34.00

weldcote
metals



CHARIOT CUTTING GUIDE

- Cuts circles up to 39" in diameter
- Cuts holes as small as 5/8" when used without the axles
- Bevells circles up to 36" in diameter
- Cut straight, irregular shapes, circles and bevel with this versatile tool
- Plated steel construction at heat stress points
- Universal bushing fits all conventional torches

Model No. 496-1040
Mfg. No. 24219
Price/Each \$134.00

flange wizard tools



MAGNETIC CIRCLE LAYOUT & BURNING GUIDE

- Layout tool with sliding soapstone holder and 360° scale on the magnetic base
- Cuts circles up to 30" in diameter
- Mark bolt circles and hole locations in a snap with this layout scale and sliding soapstone holder
- As a circle burning guide, use this same tool to cut a round plate
- Magnet is strong enough to support the weight of your torch, which frees your hands for more cutting control
- Never use the magnetic base or suction cups when cutting small holes

Model No. 496-1050
Mfg. No. 28439
Price/Each \$146.00

flange wizard tools



CIRCLE WIZ CUTTING ATTACHMENT

- Made of finished high quality steel
- Universal bushing will adapt to any size or make of conventional cutting torch
- Will cut holes from 5/8" to 8" in diameter (see 496-1040 for larger holes)
- Simply slide the center pin along the hex arm to attain the proper radius of hole desired
- Place the sharpened point in your center mark and you are ready to cut

Model No. 496-1167
Mfg. No. CW-300
Price/Each \$95.40

flange wizard tools



BALLOON FILLER REGULATORS

ECONOMY BALLOON BLOWERS

- Features straight through construction
- Rugged brass body
- Piston-type mechanism
- Hand tight CGA 580 inlet connection with sintered bronze inlet filter

Model No.	Mfg. No.	Price/Each
331-9000	229	41.60



STANDARD BALLOON BLOWERS

- Rugged all brass body
- Piston-type mechanism
- Wrench tight CGA 580 inlet connection with sintered bronze filler valve

Model No.	Mfg. No.	Price/Each
331-9020	230	64.00



PREMIUM BALLOON BLOWERS

- Rugged all brass body
- Piston-type mechanism
- Drilled and tapped for tie hook and string cutter
- Hand tight CGA 580 inlet connection with sintered bronze inlet filter
- 1 1/2", 4000 PSI rear entry inlet gauge

Model No.	Mfg. No.	Price/Each
331-9130	230HGA	85.70



GENTEC
GENSTAR TECHNOLOGIES

See pages 1115 - 1117 for
Pipe Layout Measuring Tools





CUTTING TIP CHART

MATERIAL THICKNESS	1/8	1/4	1/2	3/4	1	1-1/2	2	4	5	6	8	10	12
RECOMMENDED TIP NUMBER AND DRILL SIZE	00 / 68	0 / 60	1 / 56	1 / 56	2 / 54	2 / 54	3 / 52	3 / 49	4 / 44	6 / 38	6 / 31	7 / 28	8
OXYGEN PRESSURE SETTING LB/IN ² g	20-25	25-30	30-35	30-35	35-40	40-45	40-45	40-50	45-55	45-55	45-55	45-55	45-55
ACETYLENE PRESSURE SETTING LB/IN ² g	3-5	3-5	3-5	3-5	3-7	3-7	5-10	5-10	6-12	7-13	8-14	10-15	10-15
CUTTING IN / MIN	27-30	26-29	20-24	17-21	14-18	13-17	12-15	8-11	7-9	6-8	5-6	4-5	3-4

AIRCO® 144/ALC 802 STYLE CUTTING TIPS

- For general hand or machine cutting
- Acetylene-oxygen
- Medium preheat
- Fits Airco® 3790, 4690, 4700, 4800, 5700, 5800, 1100, 3000, 9000 and 9500 torches

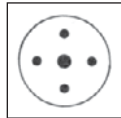

Model No.	Size	Price/Each
TTU465	00	14.50
TTU466	0	14.50
TTU467	1	14.50
TTU468	2	14.50
TTU469	3	14.50
TTU470	4	14.50
328-1351	5	16.10
328-1354	6	16.10

AIRCO® 164/ALC 803 STYLE CUTTING TIPS

- For general, cast iron and stainless steel cutting
- Acetylene-oxygen
- Very high preheat
- Fits Airco® 3790, 4690, 4700, 4800, 5700, 5800, 1100, 3000, 9000 and 9500 torches

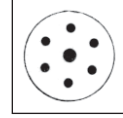

Model No.	Size	Price/Each
TTU471	00	14.50
TTU358	0	14.50
TTU359	1	14.50
TTU360	2	14.50
TTU361	3	14.50
TTU362	4	14.50
TTU472	5	14.50
TTU473	6	14.50
TTU474	7	14.50
328-1468	8	17.30

AIRCO® 261/ALC 829 STYLE CUTTING TIPS

- For general cutting, two-piece tip for hand cutting
- Propane or oxygen-natural gas
- High preheat
- Fits Airco® 2900, 3790, 4690, 4700, 4800, 5700, 5800, 1100, 3000, 9000 and 9500 torches



Model No.	Size	Price/Each
328-1681	00	21.40
TTU475	0	14.50
TTU476	1	14.50
TTU477	2	14.50
TTU478	3	14.50
TTU479	4	14.50
TTU480	5	14.50
328-1702	6	21.40
328-1705	7	21.40
328-1708	8	24.10

PUROX® 4202/ESAB STYLE CUTTING TIPS

- For general cutting
- Acetylene-oxygen
- Medium preheat
- Fits CW-200, CW-202, CW-300 Type E torches and C-205 machine torch

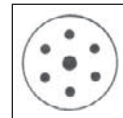

Model No.	Size	Price/Each
TTU481	3	14.50
TTU482	4	14.50
TTU483	5	14.50
TTU484	7	14.50
TTU485	9	14.50
328-3238	11	18.20
328-3241	13	18.20

SMITH® MC12 STYLE CUTTING TIPS

- For hand cutting with oxy-acetylene
- Medium preheat
- Fits Smith® cutting assemblies MC505, MC509, AC305, and AC309

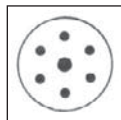

Model No.	Size	Price/Each
TTU530	1	20.70

SMITH® SC12 STYLE CUTTING TIPS

- For hand or machine cutting with oxy-acetylene
- Medium preheat
- Fits Smith® cutting attachments Silver Star and MC40
- Fits Smith® cutting torches Tuf Tony and Silver Star
- Fits Smith® machine torches SC770, SC771, SC780A, SC781A and SC782A

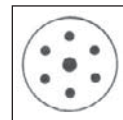

Model No.	Size	Price/Each
TTU531	1	21.30

Manufacturers names are used descriptively only to identify products with which these Replacement Tips may be used. They have no relationship with other manufacturers listed.



HARRIS® 6290 STYLE CUTTING TIPS

- For general hand cutting
- Acetylene-oxygen
- Medium preheat
- Fits Harris® 42-3, 62-3, 72, 72A, 73, 73A and 85 torches

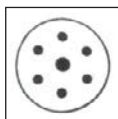

Model No.	Size	Price/Each
TTU458	000	10.95
TTU459	00	10.95
TTU349	0	10.60
TTU350	1	10.60
TTU351	2	10.60
TTU352	3	10.60
TTU460	4	10.95
TTU461	5	10.95
TTU462	6	10.95

HARRIS® 6290-NX STYLE CUTTING TIPS

- For general hand cutting
- Propane or oxygen-natural gas
- Medium preheat
- Fits Harris® 42-3, 49AF, 49F, 62-3, 72, 73, 85 and 142 torches

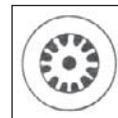

Model No.	Size	Price/Each
TTU463	000	10.95
328-2125	00	12.70
TTU353	0	10.60
TTU354	1	10.60
TTU355	2	10.60
TTU356	3	10.60
TTU357	4	10.60
TTU464	5	10.95
328-2146	6	12.70

VICTOR® 1-101 STYLE CUTTING TIPS

- For general cutting
- Acetylene-oxygen
- Machine preheat for hand and machine cutting
- Fits 2460, CA 1060, ST, SST and 1400C machine torches

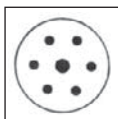

Model No.	Size	Price/Each
TTU441	000	11.05
TTU333	00	11.05
TTU334	0	11.05
TTU335	1	11.05
TTU336	2	11.05
TTU337	3	11.05
TTU338	4	11.05
TTU339	5	11.05
TTU442	6	11.05
TTU443	7	11.05
TTU444	8	11.05

VICTOR® 3-101 STYLE CUTTING TIPS

- For general hand cutting
- Acetylene-oxygen
- Medium preheat
- Fits CA 1260, CA 1350, C 1450, CA 2060, CST 800 and C 1400 torches

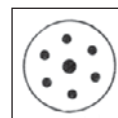

Model No.	Size	Price/Each
TTU448	000	10.65
TTU449	00	10.65
TTU340	0	10.60
TTU341	1	10.60
TTU342	2	10.60
TTU343	3	10.60
TTU450	4	10.65
TTU451	5	10.65

VICTOR® GPN STYLE CUTTING TIPS

- For general cutting
- Propane or oxygen-natural gas
- Medium preheat for hand and machine cutting
- Fits 2450, CA 1060, CAN 1060, ST, SST, STN and 1400C machine torches



Model No.	Size	Price/Each
328-3826	000	13.60
TTU452	00	10.95
TTU344	0	10.60
TTU345	1	10.60
TTU346	2	10.60
TTU347	3	10.60
TTU348	4	10.60
TTU453	5	10.95
328-3850	6	15.30
328-3853	7	15.30
328-3856	8	15.30

VICTOR® 1-118 STYLE CUTTING TIPS

- For gouging, scarfing and deseaming
- Acetylene-oxygen
- Fits 2460, CA 1060, ST, SST and 1400C torches

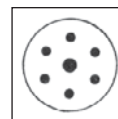

Model No.	Size	Price/Each
328-4015	0	35.90
TTU445	2	24.05
TTU446	4	24.05
TTU447	6	36.70
328-4027	8	63.60

VICTOR® 3-GPN STYLE CUTTING TIPS

- For general cutting
- Propane or oxygen-natural gas
- Medium preheat series 3 tip
- Fits CA 1260, CA 1350, C 1450, CA 2060, CST 800 and C 1400 torches



Model No.	Size	Price/Each
TTU454	0	10.95
TTU455	1	10.95
TTU456	2	10.95
TTU457	3	10.95

Manufacturers names are used descriptively only to identify products with which these Replacement Tips may be used. They have no relationship with other manufacturers listed.

GAS WELDING OUTFITS & ACCESSORIES



HEATING TIPS

TIP DIAMETERS AS FOLLOWS:

- No. 1 Tip - 11/16"
- No. 2 Tip - 11/16"
- No. 3 Tip - 13/16"
- No. 4 Tip - 1 5/16"



Model No.	Mfg. No.	Tip Size	Thread"	Price /Each
FOR USE WITH LP OR NATURAL GAS				
328-1015	221-1	1	1/2-25	59.20
328-1018	221-2	2	1/2-25	59.20
328-1021	221-3	3	1/2-25	91.50
328-1024	221-4	4	1/2-25	128.00
FOR USE WITH ACETYLENE GAS				
328-1066	230-2	2	7/16-20	50.10
328-1069	230-3	3	7/16-20	62.20
328-1072	231-1	1	1/2-25	43.70
328-1075	231-2	2	1/2-25	50.10
328-1078	231-3	3	1/2-25	62.20

221

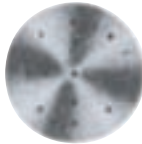

230/231

HEATING TIP ADAPTORS FOR CUTTING TORCHES

- For use with the designated cutting torches



Airco



Harris



Victor



Model No.	Mfg. No	Seat Style	Thread"	Price/Each
328-1252	801-S	Airco® Air Products	1/2-25	23.60
328-2305	1361-S	Harris® 6290	1/2-25	21.90
328-3628	2301-S	Victor® 1 Series	1/2-25	21.90

OXY-ACETYLENE & OXY-HYDROGEN HEATING NOZZLES

- Victor® compatible
- Ideal for preheating and straightening, etc.



Model No.	Mfg. No.	Tip Size	Duty	Oxygen PSIG	Acetylene Fuel PSIG	Oxygen SCFH	Acetylene Fuel SCFH	Victor® Equivalent	Fits	Price /Each
TTU284	172H-2	2	Medium	4/8	4/8	3/10	3/9	2-MFA-1		75.30
TTU285	172H-4	4	Medium	8/12	6/10	7/22	6/20	4-MFA-1		75.30
331-1345	172H-6	6	Medium	10/15	8/12	15/44	14/40	6-MFA-1	142T	75.30
331-1355	172H-8	8	Medium	20/30	10/15	33/88	30/80	8-MFA-1		75.30
TTU286	173H-4	4	Heavy	8/12	6/10	7/22	6/20	4-MFA		112.00
331-1495	173H-6	6	Heavy	10/15	8/12	15/44	14/40	6-MFA	143T/143TL/	112.00
331-1500	173H-8	8	Heavy	20/30	10/15	33/88	30/80	8-MFA	143TLH	113.00
TTU287	173H-10	10	Heavy	30/40	12/15	44/110	40/100	10-MFA		142.00

Manufacturers names are used descriptively only to identify products with which these Replacement Tips may be used. They have no relationship with other manufacturers listed.

See pages 1120 - 1128
for Welding Helmets
& Lenses



GAS WELDING OUTFITS & ACCESSORIES

SPIRAL TIP CLEANERS

- Cleaning data on back of case
- Hardened steel file included in each case
- Choice of standard or extra long king set
- Quality aluminum case



Model No.	Description	No. of Cleaners	Price /Each
NT641	Standard Set	12	2.50
TTV223	King Set	13	2.59



TIP DRILL KITS

- Cleans cutting tips and a variety of other fuel orifices and injectors
- Includes 10 drills in sizes 52-74
- Promotes more effective fuel use and increases performance in welding, cutting and heating tips
- Drills store neatly in pipe vise handle

Model No. NT660
Price/Each \$11.35



WELD FILLET GAUGES

- Precision gauge
- Covers eleven sizes from 1/8", 3/16", 1/4", 5/16", 3/8", 7/16", 1/2", 5/8", 3/4", 7/8" and 1"
- Constructed of rust proof 22 gauge, type 304 steel
- Die blanked to eliminate sharp edges - adds to accuracy
- Permanently etched and black filled lettering for long life and abrasion resistance

Model No. 704-5015
Mfg. No. MWFG
Price/Each \$31.20



TIP-NIP TIP REFACERS

- For easy, fast precision tip resurfacing
- Insert tip and give a few turns
- Pitted tip is resurfaced for new performance
- Extends tip life

Model No. NT820
Price/Each \$22.50



THREE-FLINT LIGHTERS

- Heavy-duty steel band with three flints attached
- Dependable ignition under all working conditions



Model No.	Mfg. No.	Description	Price/Each
322-1240	4501	Spark Lighter	7.14
322-1320	5012X	Three-Flint Renewal, 4/Pkg.	6.00

UNIVERSAL SINGLE FLINT LIGHTERS

- Square hood wrapped around the frame
- Under the hood is the round file which spins, always assuring a fresh spark
- Replaceable flints



Model No.	Mfg. No.	Description	Price/Each
322-1540	3001	Spark Lighter	4.34
322-1560	3001X	Single Flint Renewal, 5/Holder	2.04

FLINT LIGHTERS

- Choice of single or three-flint lighters
- Additional flints sold separately

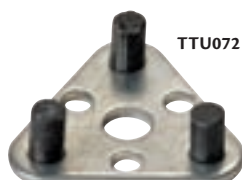

Model No.	Description	Price/Each
NT642	Single Flint Lighter	2.50
TTU432	Single Flint Lighter w/ 5 Flint Holders	10.25
NT663	Flints, 5 per Holder	1.75
TTU071	Three-Flint Lighter	3.35
TTU072	Flints - Each	0.95



10-WAY CYLINDER WRENCHES

- For regulators, torches and commercial acetylene cylinders
- Drop-forged, special alloy steel for maximum durability
- Baked powder coat finish

Model No. BZ944
Mfg. No. D1013
Price/Each \$7.67



TANK KEYS

- For B and MC acetylene valves, double ended

Model No. TTU322
Mfg. No. B-MC
Price/Each \$0.60



GAS WELDING OUTFITS & ACCESSORIES

QUICK-CONNECTS FOR WELDING EQUIPMENT

Western's Quick-Connects provide fast, reliable and positive connections and quick disconnections for torches, hoses and regulators. All models are color-coded for gas service for added safety (oxygen/green, fuel gas/red, inert gas/blue). Oxy/fuel gas models include integral reverse flow Check Valves. Quick-Connects fit all B-size welding and cutting equipment.

FEATURES & SPECIFICATIONS:

- Brass construction provides long service life— cycle tested over 10 000 operations indicating a service life of 10 to 12 years of comparable use
- Non-interchangeable Oxygen and Fuel Gas connectors prevent accidental gas mixing
- Instant closure on reverse flow Check Valves with total shutoff at only 10 oz. of back pressure
- Exceed CGA flow specifications—1100 SCFH flow at 125 PSIG inlet pressure and 800 SCFH flow at 125 PSIG inlet pressure when 2 additional check valves are used in conjunction with the Quick-Connects
- Spring loaded locking mechanism responds to fingertip action and achieves a gas-tight connection
- For inert gas models, demand valve on supply side creates a positive seal when fitting is not connected
- Double seal socket connection on second seal provides added safety protection
- 200 PSIG maximum operating pressure



QUICK CONNECT SETS

Model No.	Mfg. No.	Description	Components	Price/Each
312-4276	QDB10	Torch-to-Hose Set w/Check Valves	QDB11—Fuel Gas/QDB12—Oxygen/Inert	74.80
312-4280	QDB20	Hose-to-Hose Set w/Check Valves	QDB21—Fuel Gas/QDB22—Oxygen/Inert	78.80
312-4284	QDB30	Regulator-to-Hose w/Check Valves	QDB31—Fuel Gas/QDB32—Oxygen	78.80

QUICK-CONNECTS INDIVIDUAL UNITS

Model No.	Mfg. No.	Description	Components	Price/Each
TORCH-TO-HOSE				
312-4277	QDB11	Fuel Gas w/Check Valve	QDB200—Male Plug/QDB201—Female Socket	41.30
312-4278	QDB12	Oxygen/Inert Gas w/Check Valve	QDB100—Male Plug/QDB101—Female Socket	41.30
HOSE-TO-HOSE				
312-4281	QDB21	Fuel Gas w/Check Valve	QDB205—Male Plug/QDB206—Female Socket	41.40
312-4282	QDB22	Oxygen/Inert Gas w/Check Valve	QDB105—Male Plug/QDB106—Female Socket	41.40
REGULATOR-TO-HOSE				
312-4285	QDB31	Fuel Gas w/Check Valve	QDB205—Male Plug/QDB206—Female Socket	41.40
312-4286	QDB32	Oxygen w/Check Valve	QDB105—Male Plug/QDB106—Female Socket	43.10
312-4287	QDB33	Inert Gas—Regulator-to-Hose	QDB300—Male Plug/QDB301—Female Socket	41.30
312-4290	QDB34	Inert Gas—Hose-to-Machine	QDB302—Male Plug/QDB303—Female Socket	41.30

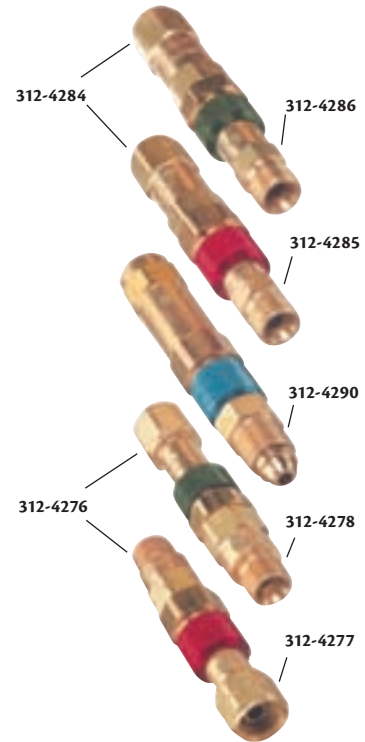

FLASHBACK ARRESTORS – OXY/FUEL GAS

Welders rely on Western's advanced Flashback Arrestors to help prevent serious incidents caused by reverse gas flows or flashbacks. Western's Flashback Arrestors are designed to stop flashbacks by preventing ignition of mixed gases and to protect equipment such as hoses, regulators and cylinders.

FEATURES & SPECIFICATIONS:

- Color-coded for gas service to provide added safety – oxygen (green), fuel gas (red)
- Internal check valves designed to prevent reverse flow and accidental mixing of oxygen and fuel gases
- Maximum operating pressures are 15 PSIG for acetylene, 22 PSIG for other fuel gases, and 125 PSIG for oxygen
- Rated capacity of 40 SCFH with a 5 PSIG pressure drop
- Torch and regulator models provide downstream and upstream protection
- 10" maximum cutting capacity
- Reusable; manual resetting not required
- UL listed and 100% tested



Model No.	Mfg. No.	Description	Components	Price/Each
312-3376	FA-10	Flashback Arrestor Set, Torch Style	FA-100P, FA-200P	73.60
312-3377	FA-30	Flashback Arrestor Set, Regulator Adaptor Style	FA-130P, FA-230P	80.20

FLASHBACK ARRESTORS INDIVIDUAL UNITS

Model No.	Mfg. No.	Description	Price/Each
312-3378	FA-100P	Flashback Arrestor, Oxygen, Torch Style	41.00
312-3380	FA-200P	Flashback Arrestor, Fuel Gas, Torch Style	41.00
312-3379	FA-130P	Flashback Arrestor, Oxygen, Regulator Adaptor Style	44.90
312-3381	FA-230P	Flashback Arrestor, Fuel Gas, Regulator Adaptor Style	44.90

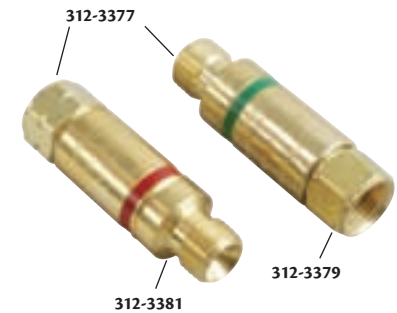

VALVED Y-CONNECTIONS, BRASS

PRESSURES TO 200 PSIG (1400 KPA)

- For use of two cutting and/or two welding torches at once
- Precision shut off valves
- B-Size (9/16"-18 Thread)



Model No.	Mfg. No.	Description	Service	Price/Each
312-1572	111	Oxygen RH: B-Size F Inlet to B-Size M Outlets	CGA-022	46.60
312-1584	112	Acetylene/F. Gases LH: B-Size F Inlet to B-Size M Outlets	CGA-023	46.60
312-1852	411	Inert Gas RH: 5/8"-18 M Inlet to 5/8"-18 F Outlets	CGA-032	58.70
312-1854	412	Water, Industrial Air LH: 5/8"-18 M Inlet to 5/8"-18 F Outlets	CGA-033	66.90



GAS WELDING OUTFITS & ACCESSORIES

BULK SINGLE LINE CORRUGATED WELDING HOSES, GRADE R

- **Green hose** is for oxygen
- **Red hose** is for acetylene use only, and where cover must resist abrasion, weather and ozone
- Heat resistant EPDM tube and cover
- Two spiral polyester yarn reinforcement, more flexible than braid reinforced hose, easier to coil and handle
- Conforms to RMA/CGA specifications
- Multi-ventilating pores disperses permeating gases, enhances welder's safety
- Working pressure: 200 PSI, 1.38 Mpa
- **Sold in full 700' reels, priced per foot**



HBD/Thermoid, Inc.

Model No.	Mfg. No.	Nominal I.D."	Nominal O.D."	Min. Bend Radius"	Price /Each
GREEN HOSES					
302-5005	00521803205	3/16	0.44	1.25	0.82
302-5020	00521804205	1/4	0.53	1.50	1.03
302-5070	00521806400	3/8	0.72	2.25	1.46
RED HOSES					
302-5000	00521903205	3/16	0.44	1.25	0.82
302-5015	00521904205	1/4	0.53	1.50	1.03
302-5065	00521906400	3/8	0.72	2.25	1.46

TULINE TWIN WELDING HOSE ASSEMBLIES

- Premium quality US made hose with "B" size brass fittings

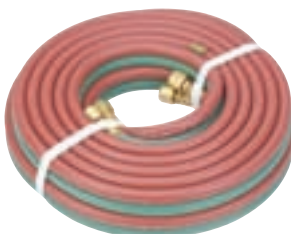

HBD/Thermoid, Inc.

Model No.	Mfg. No.	Nominal I.D."	Length'	Price /Each
GRADE R HOSES				
PB087	00521403225	3/16	25	36.80
PB090	00521484225	1/4	25	41.90
PB091	00521484250	1/4	50	69.30
PB092	00521484290	1/4	100	133.00
PB094	00521405252	5/16	50	106.00
PB095	00521405291	5/16	100	180.00
302-1260	00521406251	3/8	50	146.00
302-1270	00521406290	3/8	100	269.00

Model No.	Mfg. No.	Nominal I.D."	Length'	Price /Each
GRADE T HOSES				
PB069	00521584225	1/4	25	67.60
PB070	00521584250	1/4	50	120.00
PB071	00521584290	1/4	100	223.00
PB073	00521585250	5/16	50	153.00
302-7170	00521586250	3/8	50	154.00
302-7180	00521586290	3/8	100	289.00

HOSE REPAIR KITS

- Special B-size kit offers 12 different items most frequently used for hose repair
- Kit with C-5 crimp tool for 3/16" x 1/4" I.D. hose
- Tough polyethylene case includes handy chart that identifies and describes fittings in each compartment
- **Includes:**
 - Hose nuts & nipples
 - Splicers
 - Couplers
 - Ferrules
 - Crimping tool

Model No. NP497
Mfg. No. CK-24
Price/Each \$113.00



BULK TULINE TWIN WELDING HOSES, GRADE T

HBD/Thermoid, Inc.

- For use with all fuel gases and where a flame and oil resistant tube and cover are required
- CR (polychloroprene) tube and cover offers medium-high fuel gas resistance
- Two spiral polyester yarn reinforcement, more flexible than braid reinforced hose, easier to coil and handle
- Conforms to RMA/CGA specifications
- Multi-ventilating pores disperses permeating gases, enhances welder's safety
- Working pressure: 200 PSI, 1.38 Mpa
- **Sold in full 700' reels, priced per foot**



Model No.	Mfg. No.	Nominal I.D."	Nominal O.D."	Min. Bend Radius"	Price /Each
302-7010	00521504200	1/4	0.53	1.50	2.14

BULK TULINE TWIN WELDING HOSES, GRADE R

- **Red hose** is for acetylene use only, and where cover must resist abrasion, weather and ozone
- Heat resistant EPDM tube and cover
- Two spiral polyester yarn reinforcement, more flexible than braid reinforced hose, easier to coil and handle
- Conforms to RMA/CGA specifications
- Multi-ventilating pores disperses permeating gases, enhances welder's safety
- Working pressure: 200 PSI, 1.38 Mpa
- **Sold in full 700' reels, priced per foot**

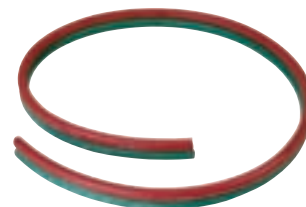

HBD/Thermoid, Inc.

Model No.	Mfg No.	Nominal I.D."	Nominal O.D."	Min. Bend Radius"	Price/Each
302-1000	00521403200	3/16	0.44	1.25	1.14
302-1010	00521404200	1/4	0.53	1.50	1.28
302-1020	00521405200	5/16	0.59	2.00	1.86
302-1030	00521406200	3/8	0.66	2.25	2.54

MIG/TIG INERT GAS HOSES

- Working pressure: 300 PSI
- Connection: 5/8" - 18 RH(M)
- I.D.: 1.4"
- Length: 6'



Model No.	Mfg. No.	Price/Each
TTU563	HA14-0061N	17.40

EMERGENCY WELDING HOSE REPAIR KITS

- **Plastic kit box contains:**
 - Standard jaw pincers
 - Oxygen "B" RH brass nuts
 - Acetylene "B" LH brass nuts
 - 1/4" brass nipples
 - 1/4" brass hose menders
 - 3/16" brass nipples
 - 3/16" brass hose menders
 - 10 1/2" 2-ear clamps
 - 40 9/16" 2-ear clamps
 - 4 9/16" twin clamps
- Model No. NP512
- Mfg. No. WK-82
- Price/Each \$129.00



REELS & WELDING ACCESSORIES

WELDING HOSE REELS

- Heavy-duty, reinforced steel stampings for increased strength
- 1/4" oxygen and acetylene twin hose
- Leakproof double O-ring seals
- Compact design allows reels to fit in tight locations
- Multi-position guide arms for multiple mounting options
- Kinkless, oil resistant high quality hose

- Spring rewind features long life spring with declutching arbor
- Grade R hose
- Durable, corrosion-resistant powder coat paint

aurora tools®

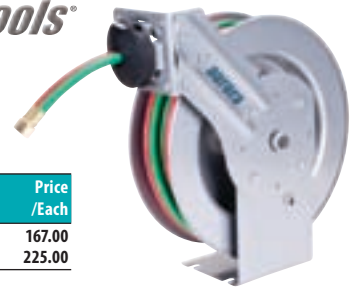

Model No.	Drive Type	Hose I.D."	Hose Length'	Max PSI	Oxygen Inlet & Outlet		Acetylene Inlet & Outlet		Dimensions			Wt lbs.	Price /Each
					W"	x	D"	x	H"				
TLZ487	Spring	1/4	25	300	9/16" x 18 UNF (Female)	9/16" x 18 UNF (Female)	8	x	14 3/4	x	13 5/8	25.9	167.00
TLZ488	Spring	1/4	50	300	9/16" x 18 UNF (Female)	9/16" x 18 UNF (Female)	8 5/8	x	20 1/2	x	20 1/2	42.2	225.00

HOSE REELS

- Heavy-duty, reinforced steel stampings for increased strength
- For use with air and water
- Compact design allows reels to fit in tight locations
- Multi-position guide arms for multiple mounting options
- Kinkless, oil resistant high quality hose

- Spring rewind features long life spring with declutching arbor
- Durable, corrosion-resistant powder coat paint
- Good for air and water

aurora tools®



Model No.	Drive Type	Hose I.D."	Hose Length'	Max PSI	Hose Outlet (M) NPT"	Reel Inlet (F) NPT"	Dimensions			Wt lbs.	Price /Each		
							W"	x	H"				
TLZ482	Spring	1/4	35	300	1/4	3/8	6	x	15 1/2	x	14	26.6	216.00
TLZ483	Spring	3/8	25	300	1/4	3/8	6	x	15 1/8	x	13 7/8	26.2	221.00
TLZ484	Spring	3/8	35	300	1/4	3/8	6 5/8	x	17 1/2	x	16 1/2	34.7	267.00
TLZ485	Spring	3/8	50	300	1/4	3/8	6 1/2	x	20	x	18 3/8	40.3	361.00
TLZ486	Spring	1/2	50	300	1/2	1/2	6 5/8	x	20 1/4	x	17 7/8	44.3	378.00

ARC WELDING REELS

POWER OR MANUAL REWIND TO HANDLE #2 THROUGH 4/0 CABLE TO 400 AMPS

- 400-amp rated rotary electrical device
- Instant use with any cable length unwound
- For use with single conductor electrode cable or grounding lead
- Quick connection to your welder
- 4-way roller assembly
- Roller position must be specified

SWCR SERIES

- Non sparking ratchet assembly
- Declutching arbor is provided to prevent damage from reverse winding
- A cable stop should be used



WCR SERIES

- Gear driven crank rewind, chain and sprocket powered by an electric, hydraulic or compressed air motor
- Auxiliary rewind and pinion brake standard

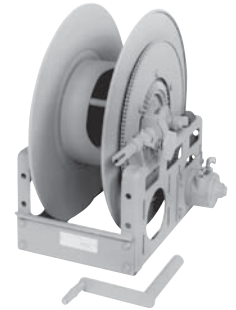

Hannay Reels®
The reel leader.

Model No.	Mfg. No.	Cable Capacity of Reel¹							Approx. Weight		Standard Roller Assembly	Price /Each
		Gauge of Cable O.D."	#2 0.50	#1 0.58	1/0 0.62	2/0 0.67	3/0 0.72	4/0 0.81	Net lbs.	Ship lbs.		
SWCR												
886-1130	SWCR716-23-24-15.5G		85	85	60	60	60	40	85	120	R204	1407.00
TTT563	SWCR716-25-26-15.5B		-	-	-	-	60	50	91	126	R204	1451.00
TTT564	SWCR716-25-26-15.5A		-	-	100	-	-	-	106	141	R205	1662.00
WCR												
886-1921	WCR16-19-21		-	275	200	200	150	150	71	106	-	1038.00
TTT565	WCR16-23-24		-	-	-	-	300	200	78	113	-	1038.00

GAS WELDING REELS

SPRING REWIND TO HANDLE TWIN 1/4" THROUGH 3/8" WELDING HOSE

- Heavy-duty spring motor
- Non sparking ratchet assembly
- Declutching arbor to prevent damage from reverse winding
- Standard inlets 90° ball bearing swivel joints 1/2" female NPT threads
- Standard outlets male 9/16"-18 threads right hand for oxygen, left hand for gas
- Pressures to 300 PSI (21 bar)
- Temperatures from -40°F to 200°F (-40°C to 93°C)
- Type of gas used MUST be specified
- 4-way roller assembly (roller position must be specified)
- Hose stop is required

Hannay Reels®
The reel leader.

Shown with optional hose and hose stop in the optional "TR" position

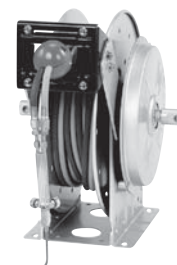

Model No.	Mfg. No.	Hose Capacity of Reel¹			Approx. Wt.		Standard Roller Assembly	Price /Each
		I.D." O.D."	1/4 0.53	3/8 0.66	Net lbs.	Ship lbs.		
TPV150	N416-17-18-8L	2/50	-	-	64	71	N204	1392.00
TPV151	N416-19-20-8L	-	2/50	-	68	75	N204	1572.00
TTT568	N416-19-20-10.5C	2/25	2/25	-	70	77	N204	923.00
886-1060	N416-19-20-8J	2/50	2/50	-	74	83	N204	992.00
TTT569	N416-23-24-10.5G	2/75	2/75	-	94	112	N204	1284.00
886-1080	N417-23-24-10.5G	2/100	2/100	-	95	115	N205	1284.00

Model No.	Mfg. No.	Description	Price /Each
886-1030	HS-3	Hose Stop	27.90

GAS CYLINDER CABINETS

- Heavy-duty construction
- 2" x 2" 10-gauge formed steel angle posts
- 9-gauge wire mesh doors and walls for venting
- 14-gauge checker plate shelves and roof
- English and French warning labels included
- Padlock hasp for added security
- Innovative door design allows for left or right opening installation
- Easy assemble, knock-down feature saves on shipping costs

Note: Constructed to meet or exceed strict CSA International B149.2-0 Propane Storage and Handling Code. Cylinders must be stored vertically at all times.



SEB837



SEB838



SAF847



SAF848



SAF837



LIQUID PROPANE (35-LB CYLINDERS)

Model No.	Dimensions				Cylinder Capacity	Wt. lbs.	Price /Each
	W"	x	D"	x H"			
SEB837*	30	x	17	x 37	2	70	486.00
SEB838*	17	x	17	x 69	2	85	583.00
SAF836	44	x	30	x 37	6	135	994.00
SAF847	44	x	30	x 74	12	270	1255.00

COMPRESSED GAS (9" DIAMETER CYLINDERS)

Model No.	Dimensions				Cylinder Capacity	Wt. lbs.	Price /Each
	W"	x	D"	x H"			
SAF837	44	x	30	x 74	10	210	1188.00
SAF848*	88	x	30	x 74	20	420	2099.00

*Consists of two units of the SAF837

*All-welded, fully assembled

ALUMINUM LPG CYLINDER LOCKER STORAGE

- Constructed of 100% welded aluminum, they won't rust, corrode or discolor
- Aluminum, expanded metal panels are the heaviest in the industry – 20% heavier than others – offering additional resistance to tampering
- Heavier gauge aluminum mesh and extruded (not bent) frame add rigidity
- Justrite® offers an exclusive solid aluminum roof panel that slants to the back to shed water and ice

Aluminum cylinder storage lockers are ideal for any facility using a forklift truck or welding equipment.

Sloped roof design sheds water and ice to the rear. Solid top reinforces stability.

Comes complete with warning and full/empty cylinder labels. Extruded framework provides superior strength.



Heavy expanded aluminum for improved security. All-welded aluminum construction resists abusive outdoor elements – won't rust or discolor.

Easy to use rack positions cylinders securely and stores 20 and 33-lb. cylinders.

Designed to accept padlock (not included) to prevent unauthorized access.

Cylinders stay clear of ground with strong floor plate.

Pre-drilled hole at each corner for anchoring. Accepts 1/2" anchor maximum security and stability.

Complies with NFPA 58 and OSHA 1910.110 or CSA-B149.2.



SAI577



SAI576

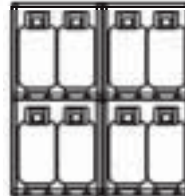

SAI575



SAI574

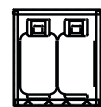

SAI573



Model No.	Mfg. No.	Description	Cylinder Type	Capacity	Dimensions			Wt. lbs.	Price /Each
					W"	x	H" x D"		
SAI573	23009	4-Cylinder Vertical	LPG	4 - 20 or 33-lb cylinders	30	x	33 1/2 x 32	79	1588.00
SAI574	23010	8-Cylinder Vertical	LPG	8 - 20 or 33-lb cylinders	30	x	65 x 32	114	2122.00
SAI575	23011	16-Cylinder Vertical	LPG	16 - 20 or 33-lb cylinders	60	x	65 x 32	211	3847.00
SAI576	23006	10-Cylinder Vertical	Compressed Gas	Up to 10 comp. gas cylinders	30	x	65 x 32	102	1791.00
SAI577	23007	20-Cylinder Vertical	Compressed Gas	Up to 20 comp. gas cylinders	60	x	65 x 32	187	3284.00

REELS & WELDING ACCESSORIES



GAS CYLINDER CARTS

• Choice of carts for a wide range of cylinder sizes and terrains

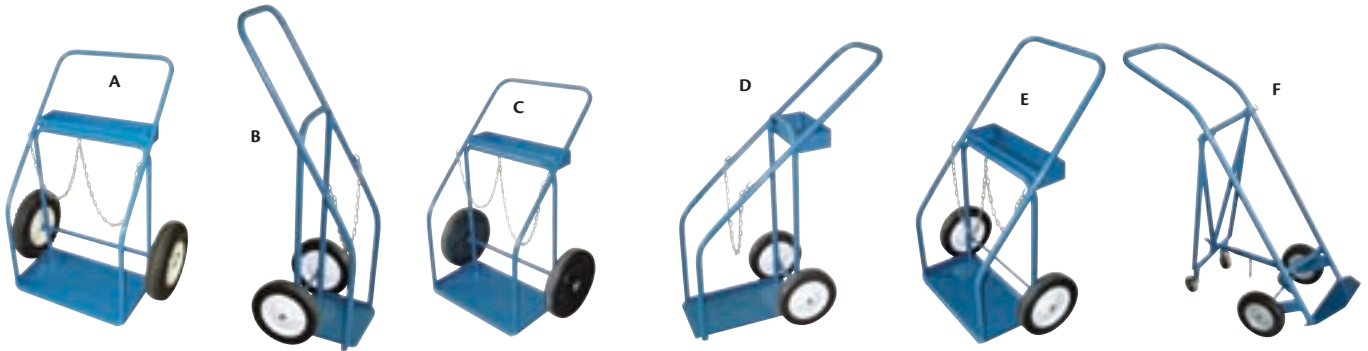

Model No.	Base W" x D"	Wheel Type	Capacity	Weight lbs.	Price /Each	
A	ML413	25 x 13	16" Dia. pneumatic	244 cu.ft. oxygen, 300 cu.ft. acetylene cylinders	55	349.00
B	ML414	12 x 10	10" Dia. semi-pneumatic	300 cu.ft. 9" Dia. cylinder	22	144.00
C	ML415	25 x 13	14" Dia. x 3" rubber	244 cu.ft. oxygen, 300 cu.ft. acetylene cylinders	55	299.00
D	ML416	12 x 18	10" Dia. semi-pneumatic	144 cu.ft. or 244 cu.ft. oxygen, 130 cu.ft. acetylene cylinders	27	145.00
E	ML417	19 x 10	10" Dia. semi-pneumatic	144 cu.ft. or 244 cu.ft. oxygen, 130 cu.ft. acetylene cylinders	30	145.00
F	TTT455	12 x 14	8" Dia. rubber semi-pneumatic	244 cu.ft. oxygen cylinder	30	349.00

MINI-MIG WELDING CARTS

MM-8 Series Cylinder Cart

- Designed to carry a variety of Mini-MIG, Inverters, and Plasma machines
- Dimensions: 18" W x 36" D x 17" H
- Weight: 48 lbs
- Cylinder capacity: 9 1/2"

Model No. ML419
Price/Each \$160.00



DUAL-CYLINDER DOLLIES

- Accommodates cylinders up to 12" in diameter, including a class 300 SCF industrial gas cylinder and a no. 5 acetylene cylinder
- Composite construction withstands extreme weather conditions
- Tough 16.5" diameter pneumatic wheels gives maneuverability on rough terrain
- 36" built-in tray holds tools, valves and torches
- Powder coat finish steel tool/supplies tray
- Handle offers maximum stability allowing for wrapping of hose equipment
- Rust, corrosion and spark resistant
- Will not dent, chip or scratch paint from cylinders
- Dimensions: 36.88" L x 23.5" W x 45" H
- Weight: 57 lbs.
- Load capacity: 500 lbs.

Model No. SAP856
Mfg. No. 7302-BK
Price/Each \$854.00



FOUR-WHEEL CYLINDER HAND TRUCKS

- Fully welded construction of heavy 11 and 10-gauge steel with 3/16" thick steel supports and 1" diameter by 14-gauge round steel tube for maximum strength
- These durable units include two 10.5" pneumatic tires to provide easy transportation of medical, industrial and commercial use gas cylinders
- Swing-down steel carriages allow use of rear swivel casters for additional safety and control
- Single cylinder trucks handle cylinders up to 12" in diameter; dual cylinder carts can handle cylinders up to 10" in diameter
- Heavy poly straps with cinch buckle system provide security during transport
- Epoxy powder coat finish for durability
- Load capacity: 1000 lbs.



MOBILE CYLINDER SUPPORTS

- Securely holds four cylinders up to 12" in diameter even in transit
- Constructed from 11-gauge, all-welded steel with grey enamel finish
- Includes push handle and easy rolling caster or without handle and casters for forklift attaching
- Dimensions: 24" W x 40" D x 36" H
- Load capacity: 1200 lbs.



Model No.	Mfg. No.	Description	Dimensions L" x W" x H"	Wt. lbs.	Price /Each
MK817	G-904	Single Cylinder Hand Truck	19 x 21 x 47	48	549.00
MK818	G-953	Dual Cylinder Hand Truck	20 x 31.5 x 47	65	625.00

Model No.	Mfg. No.	Description	Wt. lbs.	Price /Each
SB865	G-430	4 Unit Mobile Cylinder Cart	153	1117.00
SB866	G-450	4 Unit Mobile Cylinder Cart (forklift attachment)	122	999.00

GAS CYLINDER POLY-STANDS

- Free-standing design maximizes floor space
- Made of polyethylene resisting sparking, rust and corrosion
- Prevents accidental tipping with durable nylon straps to keep cylinders and stand secure
- Ideal for inexpensive wall-mounted storage
- Accommodates two cylinders 3" to 12 3/8" diameter
- Dimensions: 28" W x 14" D x 30" H
- Handling capacity of 400 lbs.
- Weight: 14 lbs.
- Colour: Yellow
- OSHA 29 CFR.1910 approved

Model No. SE966
Mfg. No. 7212-YE
Price/Each \$290.00



6-PACK CYLINDER RACKS

- Maximizes floor space
- Will not rust or corrode
- Suited for outdoor storage
- Forkliftable, crane liftable or optional black caster frame for mobility to go anywhere
- Sturdy retaining straps assure stable storage
- Optional black accessory strap can be added to bottom for extra security
- Molded-in cap holders to keep cylinder caps at hand
- Cylinder rack has a loading capacity of 1200 lbs.
- Optional black rack ramp attaches for easy manoeuvring of cylinders
- Handling capacity of 1000 lbs.
- Handles 3" to 10" diameter cylinders
- OSHA 29 CFR.1910 approved



Model No.	Mfg. No.	Description	Dimensions L" x W" x H"	Wt. lbs.	Price /Each
SE967	7202-YE	Cylinder Rack	48 x 31 x 41	62	758.00
SE968	7204-BK	Caster Frame	33 1/2 x 31 1/2 x 4 1/2	50	341.00
SE969	7205-BK	Bottom Straps	-	1	34.10
SE970	7203-BK	Rack Ramp	46 x 20 x 6	21	225.00

GAS CYLINDER BRACKETS

- Brackets are constructed of either epoxy powder coated 11-gauge hot rolled steel or type 304 stainless steel to endure the harshest environments
- Edges are protected with steel reinforced vinyl guarding to maintain cylinders and provide extra grip

- Support straps are 54" L x 1.5" W polypropylene with steel cinch buckle; strength rated at 1200 PSI
- Stainless steel models feature nylon snap buckles to provide durability under the most challenging environments
- Wall mount brackets support 4" to 12" diameter cylinders; bench mount brackets support 4" to 14" diameter cylinders



Model No.	Mfg. No.	Description	Dimensions				Wt. lbs.	Price /Each
			W"	x	D"	x H"		
SB860	G-100	Single Cylinder Wall Bracket, Grey	8	x	2 1/4	x 4 1/4	3	36.70
MK819	G-100SS	Single Cylinder Wall Bracket, Stainless	8	x	2 1/4	x 4 1/4	3	119.00
SB861	G-150	Single Cylinder Bench Bracket, Grey	8	x	2 1/4	x 4 1/4	3	91.90
MK820	G-150SS	Single Cylinder Bench Bracket, Stainless	8	x	2 1/4	x 4 1/4	3	186.00
SB863	G-200	Double Cylinder Wall Bracket, Grey	23 3/4	x	2 1/4	x 4 1/4	9	89.30
MK821	G-200SS	Double Cylinder Wall Bracket, Stainless	23 3/4	x	2 1/4	x 4 1/4	9	239.00
SB864	G-300	Triple Cylinder Wall Bracket,	35 3/4	x	2 1/4	x 4 1/4	11	113.00

UNIVERSAL MODULAR CYLINDER BRACKETS

- Design your own configuration
- Units link together to customize the amount of cylinders needed
- Attaches to any wall securely and easily
- Yellow polyethylene
- Accommodates 3" to 10" diameter cylinders
- Straps included
- Dimensions: 15.3" W x 3.3" D x 6.3" H
- Weight: 1 lbs.
- OSHA 29 CFR.1910 approved

Sold individually
Model No. SED115
Mfg. No. 7216-YE
Price/Each \$35.70



Can't find what you're looking for?

Call us today!

SOLDERING TOOLS & ACCESSORIES

PYROPEN®

- Ideal for service jobs in out of the way or confined space areas
- No batteries or electricity required
- Lightweight and easy to carry around
- Butane gas operated, will operate for up to three hours on one filling, and are ready to solder within 30 seconds
- Adjustable temperature controlled by varying gas flow
- Benefits for the outdoor servicing of electronics, radio and telecommunications
- Inactive hot air, ideal for shrink tubing, soldering and desoldering of SMD's



PYROPEN® SOLDERING KIT

- Metal carrying case complete with 3.3 mm soldering tip plus a 5.7 mm hot air tip, torch ejector, spanner, tool support clip, cleaning sponge and operating manual (fuel not included)
- Brazing torch feature offers more flexibility
- Interchangeable soldering tip and torch ejector

Model No. BW160
Mfg No. WSTA3
Price/Each \$222.00



SELF-IGNITING PYROPEN®

- Fitted with tapered needle tip plus hot air nozzle
- Protective plastic cap and operation manual (fuel not included)
- Instant push button self ignition ideal for single-handed operation

Model No. BW161
Mfg No. WPA2
Price/Each \$244.00



REPLACEMENT TIPS

Model No.	Mfg. No.	Description	Price /Each
BW165	WPT1	Taper Needle	23.50
BW166	WPT2	2.0 mm Chisel	23.50
BW169	WPT5	Taper Needle	23.50
BW172	WPT8	2.0 mm 35° Spade	23.50
BW175	WPT11	8.0 mm High Powered Chisel	28.20
BW177	WPT13	5.0 mm High Powered Long Taper Chisel	28.20

PRO SERIES HIGH PERFORMANCE SOLDERING IRONS

- Super-fast heat-up! Heats up to 900°F working temperature in just 35 seconds
- Patented design provides performance that exceeds a 60-watt iron
- Red power-on LED changes to green when iron reaches working temperature
- LED work light illuminates working surface in low-light conditions
- Co-molded grip for a comfortable feel
- Tool is designed to be self-standing, no stand is needed
- Iron uses a phono jack style plug in tip for rapid exchange
- Ideal for hobbies, kits, radios, electrical and electronics

Model No. TTU438
Mfg No. WPS18MP
Price/Each \$42.40



REPLACEMENT TIPS

Model No.	Mfg. No.	Description	Price /Each
TTU439	WPS10	Conical Tip, 0.3125"	13.70
TTU440	WPS11	Chisel Tip, 0.125"	13.70

Weller®

PORTASOL® ECONOMICAL BUTANE SOLDERING IRONS

- Self-igniting portable butane heat tool can solder, cut rope, and perform other open flame operations
- Allows anti-static soldering, ideal for electronics, avionics, cellular communications, alarm systems, marine and automotive
- Rugged stainless steel body
- Up to 125 W of power
- Fully adjustable up to 1076°F (580°C)
- Runs up to two hours on single refill
- Fuel level is clearly visible through a window on the body of the tool for quick filling
- Auto switch safety shut-off, iron plated tips
- Built-in filter reduces chance of problems caused by contaminated fuel
- **BW163** kit includes the iron, sponge, stand, and extra tips in a blow molded box



Model No.	Mfg. No.	Description	Price/Each
BW200	PSI100C	Portasol® Soldering Tool	117.00
BW163*	PSI100K	Portasol® Soldering Tool Kit	156.00

* Comes with **BW193** 2.4 mm double flat tip, **BW196** hot blower, **BW195** 4.8 mm double flat tip, **BW197** hot knife, cleaning sponge, storage case (fuel not included).

REPLACEMENT TIPS



Model No.	Mfg. No.	Description	Price /Each
BW188	PSI1	1.0 mm Single Flat	17.90
BW189	PSI2	2.4 mm Single Flat	17.90
BW190	PSI3	3.2 mm Single Flat	17.90
BW191	PSI4	4.8 mm Single Flat	17.90
BW192	PSI5	1.0 mm Double Flat	17.90
BW193	PSI6	2.4 mm Double Flat	17.90
BW194	PSI7	3.2 mm Double Flat	17.90
BW195	PSI8	4.8 mm Double Flat	17.90
BW196	PSI9	Hot Blower Tip	17.90
BW197	PSI10	Hot Knife Tip	17.90

Note: Temperature range for tips is up to 850°F (450°C).

Weller®

PREMIUM BUTANE

- Recommended for users of butane soldering tools
- Filtered to a much higher degree than standard butane, will extend tool life by preventing gumming up of butane soldering tool orifices
- 60-g canister

Model No. BW164
Mfg No. WB1C
Price/Each \$6.99

Weller®



SOLDERING GUNS

- 120 volts
- Heat resistant plastic housing
- Fingertip trigger for high or low output selection
- Ready to use in six seconds
- Heavy gauge, high efficiency, tin-plated copper tip
- Twin lights illuminate work



KITS

TW149 and TW151 include: Soldering gun with one soldering tip, one sealing tip, one cutting tip, one flux brush, soldering aid tool and a coil of lead free solder. Packed in plastic carrying case.

GUNS & KITS

Model No.	Mfg. No.	Description	Watts	Price /Each
TW148	D550	Professional Soldering Gun	260/200	83.00
TW149	D550PK	Professional Soldering Gun Kit	260/200	93.80
TW150	D650	Industrial Soldering Gun	300/200	113.00
TW151	D650PK	Industrial Soldering Gun Kit	300/200	118.00

Weller®

REPLACEMENT SOLDERING GUN TIPS

Weller® tips are made of copper and are compatible with Weller® soldering guns. Available in cutting, smoothing and standard tips.



Cutting



Smoothing



Standard

Model No.	Mfg. No.	Description	Price /Each
PROFESSIONAL			
TW152	6130	Cutting Tip w/Hex Nut	7.62
TW153	6150	Cutting Tip Only	7.62
TW154	6140	Smoothing Tip w/Hex Nut	7.62
INDUSTRIAL			
TW155	6160	Smoothing Tip Only	7.48
TW156	7250	Standard Tip Only, 2/Pkg.	7.62
TW157	7250N	Standard Tip w/Hex Nut	7.62

HIGH PERFORMANCE LED SOLDERING IRONS

- Three LED lights help illuminate the work area
- Round co-molded soft grip handle design for easy tip positioning
- Triangular handle area for maximum tip control
- Ceramic insulated stainless steel encased heater construction
- Excellent quality consumer iron 8 1/4" long
- Cord length: 5'
- Tip and iron stand included
- TTV156 and TTV158 include lead-free solder and soldering aid tool
- cUL listed



Model No.	Mfg. No.	Description	Volts	Watts	Temp °F/°C	Standard Tip	Price /Each
TTV155	SP25NCN	Standard Duty	120	25	750/400	TW162	29.90
TTV156	SP25NKN	Standard Duty - Kit	120	25	750/400	TW162, TW163, TW164	35.00
TTV157	SP40NCN	Medium Duty	120	40	900/482	TW166	35.00
TTV158	SP40NKN	Medium Duty - Kit	120	40	900/482	TW166, TW640, TW644	42.10
TTV159	SP80NCN	Heavy Duty	120	80	900/482	TEF844	49.00

Weller®

TIPS

Replacement tips are nickel-plated copper or iron-plated copper for heavy-duty irons.

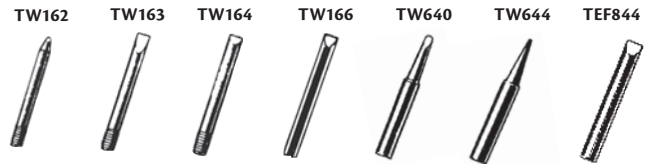

Model No.	Mfg. No.	Description	Tips	Use With Iron No.	Tip Size"	Price /Each
TW162	MT1	Cone Shaped Tip, 2/Pkg.	Nickel Plated	TTV155, TTV156	1/8	7.48
TW163	MT2	Screwdriver Tip, 2/Pkg.	Nickel Plated	TTV155, TTV156	1/8	7.48
TW164	MT3	Chisel Tip, 2/Pkg.	Nickel Plated	TTV156	1/8	7.48
TW166	MT10	Chisel Tip, 2/Pkg.	Nickel Plated	TTV157, TTV158	1/4	13.40
TW640	ST3	Screwdriver Tip	Iron, Nickel, Chromium Plated	TTV158	1/8	7.05
TW644	ST7	Conical Tip	Iron, Nickel, Chromium Plated	TTV158	0.031	5.43
TEF844	MTG20	Chisel Tip	Iron Plated	TTV159	3/8	12.60

PROFESSIONAL SOLDERING IRONS

IDEAL FOR A WIDE VARIETY OF ELECTRONICS TASKS

- Interchangeable heater elements with quick change collar
- Lightweight handle with cushion grip
- Use ST Series tips only



Model No.	Mfg. No.	Description	Volts	Watts	Hz	Price /Each
TW633	WP25	Soldering Iron w/TW640 Tip	120	25	50/60	67.00
TW634	WP35	Soldering Iron w/TW640 Tip	120	35	50/60	83.00

ST SERIES TIPS

Solid copper, plated with iron, nickel and chromium. Precision ground tips provide maximum heat transfer from heater to tip.



Model No.	Mfg. No.	Description	Tip Size"	Reach"	Price /Each
TW638	ST1	Screwdriver Tip	0.062	0.75	5.43
TW639	ST2	Screwdriver Tip	0.093	0.75	5.43
TW640	ST3	Screwdriver Tip	1/8	0.75	7.05
TW641	ST4	Screwdriver Tip	0.187	0.75	7.05
TW642	ST5	Single Flat Tip	0.031	0.75	5.43
TW643	ST6	Screwdriver Tip	0.031	0.75	5.57
TW644	ST7	Conical Tip	0.031	0.75	5.43
TW645	ST8	Narrow Screwdriver Tip	0.062	0.75	5.57

Weller®

SOLDERING TOOLS & ACCESSORIES

WTCPT TEMPERATURE CONTROLLED SOLDERING STATIONS

Suitable for production, rework and repair of through hole and SMT boards, some ground planes and multi-layer boards. Repetitive soldering at a consistent temperature.

- A ferromagnetic temperature sensor in the tip controls tip temperature - no adjustments are necessary
- A lighted rocker switch indicates on/off status
- Quick disconnect plug for soldering iron allows fast iron change
- Power unit features impact resistant plastic for durability
- ESD safe to protect sensitive components

Model No. BW009
Mfg No. WTCPT
Price/Each \$272.00

PENCIL

Model No. BW010
Mfg. No. TC201T
Price/Each \$145.00



PT SERIES TIPS FOR BW010 SOLDERING PENCIL

Model No.	Mfg. No.	A"	B"	C"	Price /Each
SCREWDRIVER - 700°F					
BW035	PTA7	0.062	0.032	0.62	5.29
BW037	PTB7	0.093	0.020	0.62	5.29
BW039	PTC7	0.125	0.027	0.62	5.29
BW041	PTD7	0.187	0.035	0.62	5.29
LONG SCREWDRIVER - 700°F					
BW046	PTJ7	0.031	0.012	1.00	5.29
BW047	PTK7	0.046	0.026	1.00	5.29
CONICAL - 700°F					
BW052	PTP7	0.031	0.012	0.62	5.29
LONG CONICAL - 700°F					
BW051	PT07	0.031	0.044	1.00	5.29

Weller®

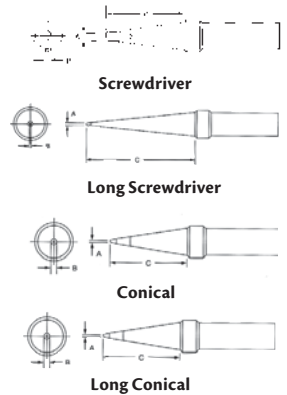

WES51 ANALOG SOLDERING STATIONS

- Station automatically powers down after 90 minutes of inactivity to prolong tip life and save power
- Improved plug on the TEF891 iron and new receptacle on the power unit for easier iron replacement
- Designed for continuous production soldering
- Slim, comfortable pencil reduces operator fatigue

Model No. TEG036
Mfg No. WES51
Price/Each \$189.00

PENCIL

Model No. TEF891
Mfg. No. PESS1
Price/Each \$69.30



Weller®

WESD51 DIGITAL SOLDERING STATIONS

- Microprocessor controlled with digital LED display allows you to read temperature setting and actual tip temperature
- Can switch between °F and °C

Model No. TEG038
Mfg No. WESD51
Price/Each \$273.00

PENCIL

Model No. TEF891
Mfg. No. PESS1
Price/Each \$69.30



Wireless temperature lockout gives you control over the process

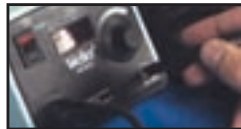

Weller®

ET SERIES TIPS FOR TEF891 SOLDERING PENCIL

Model No.	Mfg No.	A"	B"	C"	Price/Each
SCREWDRIVER					
BW087	ETA	0.062	0.032	0.625	6.02
BW088	ETB	0.093	0.020	0.625	6.02
BW089	ETC	0.125	0.027	0.625	6.02
CONICAL					
BW092	ETP	0.031	0.012	0.625	6.02
LONG CONICAL					
BW100	ETO	0.031	0.044	1.000	6.02
BW101	ETS	0.015	0.000	1.000	6.02

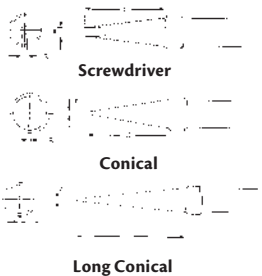

WD1002 DIGITAL SILVER SERIES SOLDERING STATIONS

HIGH PERFORMANCE SOLDERING STATION

- Features a powerful 80-watt soldering iron that is ideal in the most demanding soldering applications including high volume production soldering or high mass soldering and especially lead free soldering
- Fast temperature recovery allows to safely and efficiently solder lead free components and greatly contribute to increased productivity in traditional lead based soldering applications
- Base station features three user programmable "radio buttons" that allow to instantly switch to another temperature
- LCD screen gives the operator all important information at a glance providing an extensive user friendly menu for the operator to custom set the station to his own needs
- Programmable features include set back temperature to conserve tip life, auto shut off, temperature lockout, switching between degrees Fahrenheit or Celsius and more
- A comfortable four-position ergonomic iron stand allows you to store three optional tips for different soldering applications
- Iron comes with the TEF746 chisel tip (0.063")
- Additional tips available

Model No. TTU437
Mfg No. WD1002
Price/Each \$542.00

PENCIL

Model No. BW119
Mfg. No. WP80
Price/Each \$199.00



Weller®

LT SERIES TIPS FOR BW119 SOLDERING PENCIL

Model No.	Mfg. No.	A"	B"	C"	Price /Each
CHISEL					
TEF746	LTA	0.063	0.028	0.380	6.89
TEF754	LTH	0.031	0.016	0.430	6.89
TEF755	LTK	0.047	0.016	0.730	6.75
ROUND					
TEF738	LT1	0.010	-	0.430	6.89
TEF739	LT1L	0.008	-	0.980	6.89

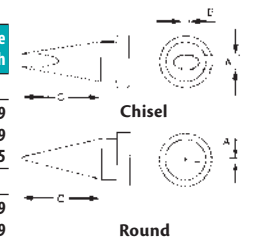

See page 1140 for Wire Solder



SOLDERING TOOLS & ACCESSORIES

OXYGEN/MAP-PRO™ GAS BRAZING/WELDING/CUTTING TORCH KITS

- Uses oxygen and propane or propylene gas

Includes:

- Burner wand
- Hose
- Oxygen regulator
- Fuel gas valve
- Cylinder stand
- **TTU687** 14.1-oz. MAP-Pro™ gas cylinder
- **TTU688** 1.40-oz. oxygen cylinder
- Spark lighter
- 5 brazing/welding rods



Model No. TTU689
Mfg. No. BZOX2550KC
Price/Each \$150.00



PENCIL FLAME TORCH KITS

- Solid brass construction
- General purpose utility flame
- Needle valve control and filtered orifice

Includes:

- **BV769** torch head
- **TTU686** 14.1-oz. propane cylinder



Model No. TTU690
Mfg. No. BZUL100
Price/Each \$32.70



TRIGGER START TORCH KITS

- Comfortable, easy grip
- Self igniting quick-start trigger
- Uses propane gas
- Solid brass burn tip for easy repairs
- Pressure regulated to burn upside down

Includes:

- **WN961** torch head
- **TTU686** 14.1-oz propane cylinder



Model No. TTU691
Mfg. No. BZTS3000KC
Price/Each \$68.10



TRIGGER START CAST ALUMINUM MAP-PRO™ GAS TORCH KITS

- Regulated for cold weather use
- Includes stainless steel burn tubes
- Compatible with both propylene and propane gases

Includes:

- **BV756** torch head
- **TTU687** 14.1-oz. MAP-Pro™ gas cylinder

Model No. TTU692
Mfg. No. BZTS4000ZKC
Price/Each \$97.40



2-PIECE SELF-IGNITING TORCH KITS

- For small, soft soldering jobs
- Adjustable flame control knob to be used with Propane fuel

Includes:

- **TTV154** Self-igniting torch
- **TTU686** 14.1-oz propane cylinder.

Model No. TTV153
Mfg. No. WK2301
Price/Each \$49.40



SPARK IGNITING MICRO TORCHES

- Precision light soldering, polyfoam cutting and heating
- Ideal for electronic repair
- Refillable, uses butane fuel
- Burns for 80 hours
- Includes electrical soldering tip

Model No. TTU299
Mfg. No. ST2200T
Price/Each \$53.40



TRIGGER START SWIVEL HEAD TORCHES

Specially designed for convenience and accessibility.

- Solid brass regulator provides greater durability
- 360° swiveling torch head provides versatility and accessibility to tight and awkward work spaces
- Slim, one-handed trigger start eliminates the need for external ignition sources
- Double O-ring connection helps prevent gas leaks
- Uses propylene gas

Model No. WN963
Mfg. No. TS99T
Price/Each \$92.90



FUELS

14.1-OZ. PROPANE CYLINDER

Use with torches and most portable appliances requiring propane.

Model No. TTU686 Mfg. No. BZTX9 Price/Each \$9.63

14.1-OZ. MAP-PRO™ GAS CYLINDER

Propylene gas burns hotter than propane. Use only with torches and appliances specifying "for use with propylene".

Model No. TTU687 Mfg. No. BZMCG Price/Each \$14.20

1.4-OZ. DISPOSABLE OXYGEN CYLINDER

Use with propylene gas for hottest brazing performance and light cutting/welding.

Model No. TTU688 Mfg. No. BZOX9 Price/Each \$18.00

5.5-OZ. DISPOSABLE BUTANE CYLINDER

Use with refillable butane torches.

Model No. TTU636 Mfg. No. BF55 Price/Each \$6.16



TTU686

TTU687

TTU688

TTU636

ARC WELDING TOOLS & ACCESSORIES

SHORTSTUB™ ELECTRODE HOLDERS

- Grip the electrode closer to the end
- Allows you to use 20% more of the electrode than with standard tong holders
- Manufactured from copper alloy for maximum conductivity and strength
- Fibreglass insulators are designed to withstand intense heat and impact
- Will not burn, break or carbon char



Model No.	Amps	Description	Price /Each
NT629	400	Electrode Holder w/Neck Ring	17.60
NT631	600	Electrode Holder w/Neck Ring	21.40
NT630	400	Slimline – Bernard® Style Holder	17.60
NT818	-	Replacement Head for 400 Amps Electrode Holder	17.85
TTV098	-	Replacement Head for 600 Amps Electrode Holder	25.20



BERNARD® SHORTSTUB™ ELECTRODE HOLDERS

- Electrode can be used to within one inch of Shortstub™ head
- Built to last with a proven high impact, high heat separate head
- 2000-lb. gripping pressure
- Better visibility, greater hand-to-arc distance



Model No.	Mfg. No.	Amps	Electrode Capacity"	Price /Each
360-9001	405	400	1/16 - 1/4	58.40



CAM ACTION CABLE CONNECTORS



- One model fits cable sizes 4 through 4/0
- Manufactured from heavy wall precision machined brass alloy
- Cable is held securely by large dome screw
- Brass body assembly slides easily into unique heavy-duty neoprene insulator with no external screws to avoid shock hazards
- Cam locking connectors are compatible with most common brands

Model No.	Description	Price /Each
NT664	Male/Female Connector Set	18.35
NT649	Male Half with Insulator	9.65
NT650	Female Half with Insulator	8.40



EITHER-END CABLE CONNECTORS

- For use with 1/0 - 2/0 cable
- Unique "Either-End" design allows ends to interlock without the need for male/female connection points
- Brass body assembly slides into heavy-duty neoprene insulator



Model No.	Mfg. No.	Description	Price /Each
NP528	E-102M	Either-End Connector Set	53.10



LC-10 CABLE CONNECTORS



- Positive lock-tight action
- Metal parts are precision machined from heavy, specially shaped brass extrusion
- Cam action design of male half connector pulls the two halves tightly together
- Female brass connector is recessed to minimize accidental shorting
- Molded connector covers
- 250 Amps
- Cable capacity: 4 - 1/0

Model No.	Mfg. No.	Description	Price /Each
380-1610	05040	Complete Connector Set	26.40
380-1620	05043	Male Half	13.20
380-1615	05046	Female Half	13.20



ELECTRICAL PLUGS & RECEPTACLES

- For use with copper or aluminum wire
- **Plug** - Universal angle ground, 50 amps, 250 volts, male
- **Receptacle** - 50 amps, 250 volts



Model No.	Mfg. No.	Description	Price /Each
NP495	42	Plug	27.75
NP496	1252	Receptacle	35.50



ARC WELDING TOOLS & ACCESSORIES

HAMMER-ON LUGS

- Manufactured from heavy wall cast copper alloy, annealed for maximum conductivity
- Fast, easy installation, just slide into cable and strike it with hammer for durable connection



Model No.	For AWG Cable Sizes	Price /Each
NT606	1 - 4	7.79
NT605	1/0 - 2/0	8.52
NT604	3/0 - 4/0	12.57

SOLDER/CRIMP LUGS

- Manufactured from heavy wall copper alloy, annealed for maximum conductivity
- Long length and flared ends make installation fast and easy



Model No.	For AWG Cable Sizes	Price /Each
TTU567	1 - 4	1.85
TTU568	1/0 - 2/0	3.10
PB131	3/0 - 4/0	6.08

TOUGHFLEX™ WELDING CABLE

- Industry's best selling welding cable
- Durable and flexible
- Highly flexible annealed 30 (0.010) gauge bare copper conductor, insulated with an EPDM jacket and paper separator
- Durable jacket resists cuts, tears, abrasion, grease, oil, water and flame
- Operating temperature range: -50°C to 105°C (-58°F to 221°F)
- Rated to 600 V
- Ideal for any welding application that requires leads, grounds, and stinger/whips
- Custom lengths and jacket colours available upon request
- **Sold per spool or boxed**



TLV126



TLV134



KALAS

CABLE SPECS:

Gauge	Stranding	O.D."	Average Wall"	Weight lbs./1000'	Resistance OHMS/1000'
#6	259/0.010	0.320	0.060	113	0.406
#4	364/0.010	0.348	0.060	147	0.287
#2	624/0.010	0.420	0.060	236	0.167
#1	780/0.010	0.503	0.080	313	0.137
1/0	988/0.010	0.533	0.080	378	0.110
2/0	1235/0.010	0.586	0.080	463	0.086
3/0	1539/0.010	0.625	0.080	563	0.070
4/0	2014/0.010	0.720	0.080	734	0.055

AMPACITY GUIDE:

GAUGE	50'	75'	100'	125'	150'	175'	200'	225'	250'	300'	350'
#4	100	100									
#3	150										
#2	200	150	100	100							
#1	250/300	200	150		100						
1/0	350	250	200	150		100	100				
2/0	400/450	300	250	200	150	100	100	100			
3/0	500	350/400	300	250	200	150	150		100		
4/0	550/600	450/500	350/400	300	250	200	200	150	150		100

DO NOT USE for 600 volt in-line applications. Product for welding applications only. Values are nominal and approximate.

Model No.	Mfg. No.	Gauge	Price /Each
300' SPOOL			
TTV126	640069.A4.001	#6	P.O.A.
TTV127	640068.A4.001	#4	P.O.A.
TTV128	640067.A4.001	#2	P.O.A.
TTV129	640066.A4.001	#1	P.O.A.
TTV130	640065.A4.001	1/0	P.O.A.
TTV131	640064.A4.001	2/0	P.O.A.
TTV132	640063.A4.001	3/0	P.O.A.
TTV133	640062.A4.001	4/0	P.O.A.
50' BOXED			
TTV134	06T1050B0000	#6	P.O.A.
TTV135	04T1050B0000	#4	P.O.A.
TTV136	02T1050B0000	#2	P.O.A.
TTV137	01T1050B0000	#1	P.O.A.
TTV138	10T1050B0000	1/0	P.O.A.
TTV139	20T1050B0000	2/0	P.O.A.
TTV140	30T1050B0000	3/0	P.O.A.
TTV141	40T1050B0000	4/0	P.O.A.
100' BOXED			
TTV142	06T1100B0000	#6	P.O.A.
TTV143	04T1100B0000	#4	P.O.A.
TTV144	02T1100B0000	#2	P.O.A.
TTV145	01T1100B0000	#1	P.O.A.
TTV146	10T1100B0000	1/0	P.O.A.
TTV147	20T1100B0000	2/0	P.O.A.
TTV148	30T1100B0000	3/0	P.O.A.
TTV149	40T1100B0000	4/0	P.O.A.

See pages
1348 - 1350 for
our full line of
Cable Cutters



HIGH-LEVERAGE CABLE CUTTERS

- High-leverage jaws with shear-cut blades
- Cuts up to: 4/0 aluminum cable (not ACSR), 2/0 soft copper cable
- Plastic covered, non-slip grips
- Compact cutter fits in most tool pouches
- NOT an insulated tool
- Overall length: 9 1/2"

Model No. TBG092
Mfg. No. 0890CSJ
Price/Each \$46.20

H.K. Porter®



ARC WELDING TOOLS & ACCESSORIES



GROUND CLAMPS

- Manufactured from nickel-plated steel with forged brass conductors
- Heavy-duty springs provide positive strength at jaws
- **NT661** is ideal for farm welder and light shop work; current flows directly from lower jaw to welding cable
- **NT662** is ideal for portable gas drive welders; braided zinc coated copper strap carries current to both upper and lower jaws, fully insulated hinge and spring prevents arcing



Model No.	Amps	Price /Each
NT661	300	5.40
NT662	500	10.10

HEAVY-DUTY C-STYLE GROUND CLAMPS

- C-type jaws are adjusted by screw lever
- Rubber insulated cable connector

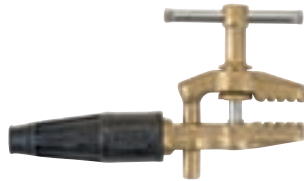

Model No.	Amps	Price /Each
NT665	600	51.50

MAGNETIC HOLDERS

- Multi-purpose holders for assembly and positioning
- Adheres to any metal object
- Ideal for welding, soldering, assembly and pipe installation



Model No.	Description	Dimensions"	Price /Each
NT626	Medium	5 x 3 1/4 x 1/2	3.75
NT627	Large	6 1/4 x 4 x 3/4	6.25
NT628	X-Large	8 x 5 x 1	9.55

MAGNETIC WELDING SQUARES

- Provides fast set-up and accurate holding of steel sheet stock, plate and tubing for welding
- Holds work pieces at 45°, 90°, 135° and 180° angles
- **TGY629**, **TYO502** and **TGY630** models feature "Breakaway Handle"



Model No.	Description	Pull lbs.	Dimensions L" x W" x H"	Price /Each
TGY624	Multi-Angle	55	4 3/8 x 3/4 x 3	16.20
TGY625	Compact	60	3 3/4 x 3/4 x 3 3/4	13.00
TYO501	Compact Multi-Angle	60	7 5/8 x 1 3/8 x 3 3/4	24.20
TLV266	Inside 90°, Outside 45/90°	40	4 3/4 x 9/16 x 2 3/4	32.60
TGY626	Adjustable	110	7 5/8 x 1 3/8 x 3 3/4	29.90
TGY627	Mid-Size	75	3 3/4 x 3/4 x 4 3/8	26.20
TGY628	Mid-Size, Covered*	75	3 3/4 x 3/4 x 4 3/8	32.90
TGY629	Mid-Size, Extra Power Covered HD	150	3 3/4 x 1 1/2 x 4 3/8	72.70
TYO502	Large Covered	160	8 x 3/4 x 8	92.00
TGY630	Large, Extra Power Covered*	325	8 x 1 1/2 x 8	169.00

* Weld spatter resistant cover

HEAVY-DUTY GROUND CLAMPS

- Manufactured from heavy-duty nickel-plated steel with forged brass conductors and braided copper strap to carry current to upper jaw
- Heavy-duty spring provides positive contact at jaws
- Cable is easy to install with built-in cable connector and oval point screw
- Allen-type wrench included



Model No.	Amps	Price /Each
NT668	300	15.50
NT669	500	17.90

JACKSON SAFETY* GROUND CLAMPS

- Clamps have forged copper alloy conductors
- High clamping pressure and long "finger-grip" levered handles for easy jaw opening
- Extra large contact areas for greater conductivity
- Run at a cooler temperature at higher AMPS for better arc starting
- Fully insulated pivots and springs



Model No.	Mfg. No.	Amps	Cable Capacity	Jaw Capacity"	Price /Each
140-1775	14730	200	4 - 1/0	1 1/4	17.00
140-1780	14731	300	1/0 - 2/0	1 5/8	25.00
140-1785	14732	500	3/0 - 4/0	2	33.00

MAGNETIC WELDING GROUNDS

- Powerful magnet attaches securely to your steel work surface
- Spring loaded 1/2" diameter stud assures constant electrical ground contact



Model No.	Holding Capacity lbs.	Stud Type Amperage	Diameter"	Height"	Price /Each
TGY631	35	250 A/Brass	3 1/2	2 1/4	48.40
TGY632	35	800 A/Copper	3 1/2	2 1/4	64.50

MAG90™ ON/OFF MAGNETIC SQUARES

- Locking On/Off handle for safety and ease of use
- Simple, fast work holding on multiple sides
- Eliminate the need for tedious clamping
- Can be used on flat or round steel
- Pre-tapped holes on all sides for mounting



Model No.	Pull lbs.	L" x W" x H"	Tap	Tap Depth"	Wt. lbs.	Price /Each
TYO503	150	1 1/2 x 1 1/2 x 2 3/4	#8-32	0.330	0.8	105.00
TYO504	450	3 x 2 1/2 x 4 5/8	1/4-20	0.500	4.3	309.00
TYO505	1000	4 1/4 x 4 x 4 3/4	3/8-16	0.625	10.5	602.00

WELDING GROUND CLAMP

- Dual purpose work piece clamp and welding ground
- Non-twist clamp
- Copper plating prevent weld splatter from sticking
- Beveled jaws hold both flat or round surfaces
- Deep throat jaw depth



Model No.	Jaw Capacity"	Dimensions L" x W" x H"	Wt. lbs.	Price /Each
TYO506	1000	4-1/2 x 9 x 4-7/16 x 1-1/8	1.9	91.10

AIR CARBON ARC GOUGING TORCHES

For gouging, cutting, beveling, piercing and flushing metal.

- Economical air carbon arc cutting process
- Can be used on most metals
- Chemical changes are virtually nil, as the process is primarily physical

AIR REQUIREMENTS

Ordinary compressed air as supplied by a shop airline or compressor is suitable. Most applications require 80-100 PSI.

Air

PSI:	80
kg/cm ² :	5.6
CFM:	35
CMM:	0.076

Compressor

Intermittent:	5 HP (3.73 KW)
Continuous:	7.5 HP (5.60 KW)



Model No.	Amps	Price /Each
NT667	800	185.00

AIR CARBON ARC GOUGING ELECTRODES

- Consistent copper coating DCCC
- Used for gouging out defective welds and cutting non-ferrous metals
- Electrodes are 12" in length
- **Sold per package**



Model No.	Dia."	Qty /Pkg.	Price /Each
NT632	5/32	100	22.95
NT633	3/16	50	13.90
NT634	1/4	50	16.80
NT635	5/16	50	20.05
NT636	3/8	50	27.10
NT637	1/2	50	48.05



INDUSTRIAL-DUTY SCRATCH BRUSHES

- Wood handle
- Choice of carbon or stainless steel bristles



Long Handle



Model No.	Length of Brush"	O.A. Length"	Wire Bristles	Rows	Trim Length"	Price /Each
LONG HANDLE BRUSHES						
NT607	5 3/4	13 3/4	Carbon Steel	3 x 19	1	2.50
NT608	5 3/4	13 3/4	Carbon Steel	4 x 19	1	3.15
NT611	5 3/4	13 3/4	Stainless Steel	3 x 19	1	3.85
NT612	6	10 1/4	Stainless Steel	4 x 19	1	4.75
SHOE HANDLE BRUSHES						
NT609	5 1/4	10 1/2	Carbon Steel	3 x 16	1	2.60
NT610	5 1/4	10 1/2	Carbon Steel	4 x 16	1	2.70
NT613	5	10 1/2	Stainless Steel	3 x 16	1	4.85
NT614	5	10 1/4	Stainless Steel	4 x 16	1	5.15
"TOOTHBRUSH" CLEANING BRUSH						
NT615	1 1/2"	7 3/4	Stainless Steel	3 x 7	1/2	1.20

ATLAS STEEL GRIP TOMAHAWKS®

- Heads are pinned to shafts
- Flex-O steel coil hand grips
- Head length: 6 1/2"
- Overall length: 10 1/2"



Model No.	Mfg. No.	Head Style	Price /Each
PB134	G	Chisel and Cross Chisel	15.20
PB135	H	Cone and Chisel	14.90
PB136	HCP	Cone and Cross Chisel	14.90

CHIPPING HAMMERS

- Cone and chisel head
- Spring steel handle
- Head length: 6 1/4"
- Overall length: 10 1/2"

Model No. NP532
Price/Each \$5.75



PLASTIC HANDLE CHIPPING HAMMERS

- High impact thermoplastic handles reduce impact sting
- Outlast standard wood handles
- Easy-to-find bright yellow colour
- Forged steel head, 11 7/8" overall length



Model No.	Mfg. No.	Head Style	Wt. oz.	Price /Each
380-1865	LPHCM	Cross Chisel and Pick	20	22.00
380-1875	LPHH	Chisel and Pick	16	22.00
380-1880	LPHHC	Cross Chisel and Pick	16	22.00
380-1870	LPHG	Chisel and Cross Chisel	20	23.50



ARC WELDING TOOLS & ACCESSORIES

ATLAS LONG-NEK TOMAHAWKS®

- "Fit-the-hand" hickory handle
- Deep neck steel head design offers 50% greater handle support and protection from splinter when working over edges
- Overall length: 12"



Model No.	Mfg. No.	Head Style	Head Length"	Price /Each
BZ946	WH-10	Chisel and Cross Chisel	7	23.70
BZ945	WH-20	Cone and Chisel	7 3/4	23.70
PB139	WH-30	Cone and Cross Chisel	7 3/4	23.70
378-1245	WH-40	Cone and Cross Chisel	8 1/4	24.70
378-1055	26	Replacement Handle	-	7.57

MULTI-PURPOSE MIG PLIERS

- Eight-way pliers
- Nickel plated finish
- Ideally suited for removal of hot spatter from nozzle ends, as well as many other uses



Model No.	Description	Price /Each
NP537	Pliers	12.25
NT666	Holster for Pliers	4.70

MATADOR® WELDER'S PLIERS

- Ideal for installing tips, nozzles and bushings, cutting and hammering
- Universal use for all wire feed guns
- Vanadium-steel construction is tough, durable
- Satin finish reduces rust

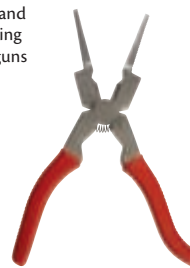

Model No.	Mfg. No.	Price /Each
899-1700	4705008	36.00

MIG NOZZLE REAMERS

- Cleans hot MIG nozzle on the torch
- Self adjusting to fit all size nozzles
- Expanding spring steel cleaner

Model No. TTU660
Price/Each \$5.95



AIR FLUX CHIPPERS

- Lightweight and compact design permits increased operator efficiency
- Paddle style trigger offers better speed control and precision
- Low noise, low vibration
- Durable
- Comes with 35 mm flat chisel
- Overall length: 10 1/4"
- Weight: 4.1 lbs.



aurora tools®

Model No.	Stroke in mm	Blows per minute BPM	Average Air Consumption CFM	Air Inlet	Hose Size in mm	Vibrations Less Than m/s ²	Sound Pressure Level dB(A)	Price /Each
TLZ133	1 1/2 38	4400	9	1/4" - 18 NPT	3/8 9.5	10.2	92	199.00

ACCESSORIES

Model No.	Description	Price /Each
TLZ134	20 mm Flat Chisel	26.95
TLZ135	35 mm Flat Chisel	26.95
TLZ136	Moil Pointed Chisel	26.95

2-PIECE WELD-ON HINGES

- Extremely popular due to its high weight load capacity as well as professional appearance
- Can be painted to match the door and frame
- Ideal for gates, machinery doors, BBQ pits, electrical boxes and trailers
- Can be welded on as a lift-off, or can be permanently mounted
- Choice of three types



Model No.	Mfg. No.	A Length"	B Pin Dia."	C Outside Dia."	D"	Price /Each
MILD STEEL W/FIXED STEEL PIN & BRASS WASHER						
QN763	FES050	2	3/16	5/16	13/32	2.25
QN761	FES080	3 3/16	5/16	1/2	5/8	3.40
QN732	FES100	4	13/32	5/8	3/4	4.49
QN741	FES150	6	1/2	3/4	1	10.60
QN751	FES200	8	5/8	29/32	1 1/8	17.90
MILD STEEL W/FIXED STEEL PIN, BRASS WASHER & GREASE FITTING						
TTT529	FES080GF	3 3/16	5/16	1/2	5/8	5.95
TTT390	FES100GF	4	13/32	5/8	3/4	7.58
TTT391	FES150GF	6	1/2	3/4	1	13.20
TTT392	FES200GF	8	5/8	29/32	1 1/8	21.10
TTT535	FES260GF	10	3/4	1 1/8	1 3/8	25.20
304 STAINLESS STEEL W/STAINLESS STEEL PIN & WASHER						
TTT536	V2A060	2 3/8	1/4	13/32	15/32	7.63
TTT537	V2A080	3 3/16	5/16	1/2	5/8	11.30
TTT538	V2A100	4	13/32	5/8	3/4	17.40
TTT539	V2A150	6	1/2	3/4	1	42.40
TTU315	V2A200	8	5/8	29/32	1 1/2	59.80

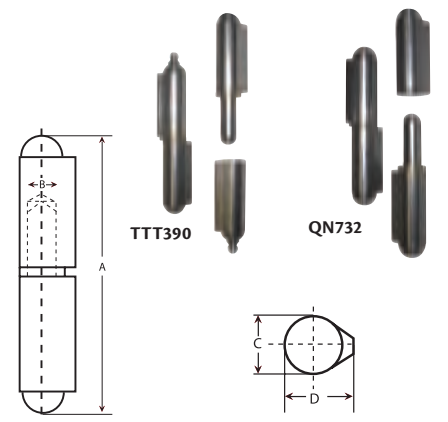

ARC WELDING TOOLS & ACCESSORIES

SAFETUBE® ROD CANISTERS

- Protects electrodes from dirt, grease and moisture
- Pressure fitted O-ring provides a watertight seal
- Withstands electrodes heated to 250°F
- Requires only a quarter turn to remove cap
- Square sides prevent rolling
- Safety yellow colour increases visibility

14" CANISTER

- Holds up to 10 lbs. (5 kg) of 14" electrodes

18" CANISTER

- Holds up to 15 lbs. (7.5 kg) of 18" electrodes

40" CANISTER

- Holds up to 15 lbs. (7.5 kg) of 36" TIG/brazing rods

CARRY STRAP

- Provides easy transport for electrode canisters
- For use with 14" and 18" Safetubes®

WALL STORAGE RACK

- Provides storage for four 40" Safetube® TIG rod canisters



ROD HOLDERS

- Double leather bottom and metal swivel clip
- 5-ply Kevlar® stitched with rivet reinforcement

Model No. NPS19
Price/Each 9.60



Model No.	Mfg. No.	Description	Capacity	Price /Each
ELECTRODE CANISTERS				
382-4010	1205441	Canister	Up to 10 lbs. of 14" Electrodes	10.50
382-4040	1205455	Canister	Up to 15 lbs. of 18" Electrodes	14.70
382-4020	1205451	Adjustable Carry Strap	-	9.70
TIG ROD CANISTER				
TTV109	1205488	Canister	Up to 15 lbs. of 36" TIG Rods	25.10
TTV110	1205490	Wall Storage Rack	-	71.70

DRYROD® PORTABLE ELECTRODE OVENS

- Heating elements provide uniform, continuous heat for 100% protection of electrodes
- Standard features include an adjustable thermostat, indicator light and removable power cord with locking power inlet
- Optional digital thermometer available on Types 2, 5, and 15, reads in °F or °C
- Type 5 and 15 available with wheels and pull-handle for easy transport
- All units cUL approved



Model No.	Mfg. No.	Voltage	Capacity lbs.	Temperature Range °F	Price /Each
TYPE 1					
382-1205500	1205500	100/240 V AC/DC @ 60 watts	10	Preset to 300	385.00
TYPE 2					
TTT575	1205512	100/240 V AC/DC @ 70 watts	20	100 - 300	450.00
382-1205510*	1205510	100/240 V AC/DC @ 70 watts	20	100 - 300	549.00
TYPE 5 W/HANDLES					
TTU576	1205523	120/240 V AC @ 300 watts	50	100 - 300	940.00
TTU577*	1205521	120/240 V AC @ 300 watts	50	100 - 300	1085.00
TYPE 5 W/WHEELS					
TTT576	1205522	120/240 V AC @ 300 watts	50	100 - 300	1010.00
382-1205520*	1205520	120/240 V AC @ 300 watts	50	100 - 300	1155.00
TYPE 15					
TTT577	1205532	120/240 V AC @ 600 watts	150	100 - 300	1750.00
382-1205530*	1205530	120/240 V AC @ 600 watts	150	100 - 300	1898.00

*With digital thermometer

DRYROD® BENCH OVENS

TYPE 15B

- Designed for small fabrication shops, jobsite trailer or welding lab
- Wire wrapped heating elements provide uniform, continuous heat for 100% protection of electrodes
- Adjustable thermostat ensures full temperature control
- Optional digital thermometer reads in °F or °C
- Powder coat finish enhances durable steel body
- cUL approved

TYPE 300

- Designed for large fabrication shops, refineries and on-site job trailers
- Ovens feature adjustable thermostatic control, indicator light and optional thermometer for instant temperature indication
- Circular shape promotes even heat distribution
- Redesigned shelving accommodates 50-lb cans
- cUL and CSA approved units



Model No.	Mfg. No.	Voltage	Capacity lbs.	Temperature Range °F	Price /Each
TYPE 15B					
TTT578	1205533	120/240 V AC @ 600 watts	150	100 - 300	1645.00
382-1205531*	1205531	120/240 V AC @ 600 watts	150	100 - 300	1810.00
TYPE 300					
382-1060	1200200	120/240 V AC @ 1000 watts	400	100 - 550	2225.00
382-1070**	1200202	120/240 V AC @ 1000 watts	400	100 - 550	2525.00
382-1065	1200100	240/480 V AC @ 1000 watts	400	100 - 550	2577.00
382-1075**	1200102	240/480 V AC @ 1000 watts	400	100 - 550	2869.00

* With digital thermometer

**Stacking version

OFFICE PRODUCTS

INSTRUMENTS, SCALES & ELECTRICAL

SHIPPING & PACKAGING

TOOLS & EQUIPMENT

WELDING & METALWORKING

SAFETY EQUIPMENT & SUPPLIES

JANITORIAL & MAINTENANCE

MATERIAL HANDLING & STORAGE

WELDING MACHINES



OUTPUT ICONS



For constant current stick and TIG processes



Direct current welding output



For constant voltage MIG, flux-cored and subarc processes



For multiprocess constant current or constant voltage applications



Alternating current welding output



Alternating or direct current welding output

INPUT ICONS



Single phase input power



115 V input power



50 Hertz input power



120 V input power



60 Hertz input power



230 V input power



50/60 Hertz input power

TOMAHAWK® 375 AIR PLASMA CUTTERS

The Tomahawk® 375 air plasma cutting system arrives ready to go for fast and precise cutting. Forget the grinder – simply pick up the torch and cut in seconds.

- Internal air compressor enables operation in environments where external compressed air is not available
- 3/8" maximum cut @ 14 IPM
- Continuous output control focuses the arc for different material thickness
- Touch start system, reliable plasma arc initiation without high frequency
- Rapid arc restrike
- Front panel purge control makes it easy to set the air flow rate without initiating the plasma arc
- Engine drive compatible
- 3-year warranty on machine, 90 days on torch



Processes

Plasma cutting for:
Mild steel, stainless steel,
aluminum, brass, copper

Output



Input



Includes:

- Internal air compressor (external air connection also standard)
- Lincoln Electric LC25 torch with 10' (3 m) cable
- Air regulator and pressure gauge
- Internal water separator
- Work clamp and cable
- Spare consumables
- Shoulder strap
- Input power cord



Model No.	Mfg. No.	Input Power Voltage/Phase/Hertz	Rated Output Current/Voltage/Duty Cycle	Input Current @ Rated Output	Pilot Current	Output Range	Air Pressure Required	Air Flow Required	Price /Each
TTU662	K2806-1	208/230/1/60	13 A/85.2 V/100% 18 A/87.2 V/60% 25 A/90 V/35%	21.7 A (max.)	17 A	10-25 A	80-110 PSI (6-7.5 Bar)	70 PSI @ 125-200 SCFH (5 Bar @ 80 Litres/min)	1983.00

TOMAHAWK® 625 PLASMA CUTTERS

The Tomahawk® 625 plasma cutting system is portable enough to carry to any jobsite. Hook up the compressed air, grab the torch and start cutting right away.

- 5/8" maximum cut @ 12 IPM
- Continuous output control focuses the arc for different material thickness
- Touch start system, reliable plasma arc initiation without high frequency
- Rapid arc restrike for fast cutting through gaps, even expanded metal
- Front panel purge control makes it easy to set the air flow rate without initiating the plasma arc
- Lightweight and portable, can be easily carried by one person
- Engine drive compatible
- 3-year warranty on machine, 90 days on torch



Processes

Plasma cutting for:
Mild steel, stainless steel,
aluminum, brass, copper

Output



Input



Includes:

- Lincoln Electric LC40 torch with 20' (6 m) cable
- Air regulator and pressure gauge
- Internal water separator
- Work clamp and cable
- Spare consumables
- Shoulder strap
- Input power cord



Model No.	Mfg. No.	Input Power Voltage/Phase/Hertz	Rated Output Current/Voltage/Duty Cycle	Input Current @ Rated Output	Pilot Current	Output Range	Air Pressure Required	Air Flow Required	Price /Each
TTU663	K2807-1	208/230/1/50/60	24 A/89.6 V/100% 29 A/91.8 V/60% 40 A/96.0 V/35%	36.8 A (max.)	17 A	10-40 A	80-110 PSI (6-7.5 Bar)	70 PSI @ 125-200 SCFH (5 Bar @ 80 Litres/min)	2793.00

INVERTEC® V155-S STICK/TIG WELDERS

PORTABLE, PROFESSIONAL, RUGGED, AFFORDABLE

- Weighs less than 15 lbs. (6.8 kg)
- 120/230 V auto reconnect operation, can operate from a portable generator
- Plugs into a 200' (61 m) 230 V extension cord so you can weld just about anywhere
- Tough dent resistant case is IP23-rated for outdoor use
- Two stick modes, SOFT and CRISP, provide the right arc characteristics for different types of electrodes
- Auto-Adaptive Arc Force™ minimizes electrode sticking in the puddle without compromising arc stability or increased spatter
- Automatic Hot-Start™ boosts the current during starting to make striking an arc easier
- Touch Start TIG™ DC operation allows you to strike the arc easily without high frequency or tungsten contamination
- Available in two models: a base unit (TTU115) with stick accessories or a complete Stick/TIG ready-to-weld package (TTU116) in an Easy-Store/Easy-Carry suitcase
- 3-year warranty on parts and labour



TTU116

Processes

Stick
DC TIG

Output



Input



Includes:

- Invertec® V155-S
- Stick electrode holder, cable and Twist-Mate™ plug
- Work cable and clamp with Twist-Mate™ plug
- Fully adjustable shoulder strap
- 120/230 V 6.6' (2 m) input cord with a 120 V 15 Amp plug
- Extra 120 V 20 Amp plug

Ready-Pak® Includes:

- All of the above plus
- Gas regulator
- PTA-17V TIG torch with Ultraflex™ cable and Twist-Mate™ adapter
- PTA-17 TIG accessory kit
- Easy-Store/Easy-Carry suitcase



Model No.	Mfg. No.	Input Power Voltage/Phase/Hertz	Rated Output Current/Voltage/Duty Cycle	Input Current @ Rated Output*	Output Range	Price /Each
TTU115	K2605-1	120/1/50/60	75A/23.0V/100% Stick 100A/24.0V/30% Stick 105A/14.2V/100% TIG 130A/15.2V/30% TIG	24.0A 33.8A 21.5A 28.8A	5-155 Amps DC Max. OCV: 75V	1530.00
TTU116	K2606-1	230/1/50/60	100A/24.0V/100% Stick 145A/25.8V/30% Stick 100A/14.0V/100% TIG 155A/16.2V/30% TIG	21.0A 31.0A 14.1A 22.8A	5-155 Amps DC Max. OCV: 75V	2125.00

* Input amps on 60 Hz input

PRECISION TIG® 225 STICK/TIG WELDERS

GREAT FOR CUSTOM FABRICATORS

The Precision TIG® 225 gives you the "Power to PerformSM", for general fabrication, automotive/motorsports, vocational schools or serious hobby work. Micro-Start™ II Technology delivers precision arc performance to improve arc starting, welding and weld cratering.

- 5-230 amps is the widest welding range in its class
- Patented Micro-Start™ II Technology delivers extremely stable low amperage starting, welding and cratering for AC and DC welding
- AC Auto-Balance™ automatically sets the optimal cleaning vs. penetration levels for great looking aluminum welds
- Built-in TIG pulser helps control heat input in the weld
- 115 volt auxiliary power receptacles with 20 amp service reliably powers water coolers or other tools
- Shielding gas sold separately
- Fan-As-Needed™ (F.A.N.) prevents overheating, reduces power consumption noise, motor wear and dust in the machine
- **Ready-Pak® with Cart** includes everything listed above and the understorage cart
- CSA C/US certified
- 3-year warranty on parts and labour



TTT399



TTT398

Processes

Stick
TIG

Output



Input



Ready-Pak® Includes:

- Precision TIG® 225
- Removable Lift Eye
- 10 ft. Work Cable and Clamp
- NEMA 6-50R Receptacle
- TIG Procedure Guide
- GTAW (TIG) Handbook
- PTA-17 One-Piece TIG Torch, 12.5'
- Gas Regulator with Hose
- Foot Amptrol®



Model No.	Mfg. No.	Description	Input Power Voltage/Phase/Hertz	Rated Output Current/Voltage/Duty Cycle	Input Current @ Rated Output*	Output Range	Price /Each
TTT398	K2535-1	Ready-Pak® Pkg.	208/230/1/60	90A/23.4V/100%	42/39A	5-230A AC	4003.00
TTT399	K2535-2	Ready-Pak® Pkg. w/cart				5-230A DC Max. OCV: 75V	4177.00

*All inputs reported include 20 amp output on 115 volt auxiliary

WELDING MACHINES

POWER MIG® 140C WIRE FEED WELDERS

THE PROFESSIONAL'S CHOICESM

- Designed for 120 volt home projects and repair, sheet metal autobody work, farm and small shop welding
- Diamond Core Technology™ delivers a forgiving arc, excellent out-of-position arc action, low spatter and a wide voltage sweet spot at a given wire feed speed for steel, stainless steel or aluminum
- Dual gear-driven cast aluminum drive rolls deliver positive traction
- Patented split wire guides ensure optimal wire alignment and a brass-to-brass gun connection aids critical conductivity
- Large industrial closed-design drive motor improves torque and enhances trouble-free performance
- No hassle tool-less design for input power changes, wire spool mounting, wire drive service and polarity changes
- Spool gun ready, remove the standard MIG gun and plug in the economical Magnum® 100SG spool gun **TTU118** (optional) for enhanced aluminum wire feeding performance
- Toughest PC board protection in the industry, potted to seal sensitive components from the environment, trayed in a tough plastic tray to add rigidity and shock resistance
- 3-year warranty on machine, 90 days on torch



Processes

Mig
Flux-Cored

Output



Input



Includes:

- Magnum® Pro 100L gun, 10' (3.0 m) cable
- Gas and Gasless Nozzles
- Cable Liner; 0.025" (0.6 mm) and 0.035" (0.9 mm) Contact Tips
- Work Cable and Clamp
- Adjustable Gas Regulator and Hose
- Spindle Adapter
- Sample Spool of 0.025" (0.6 mm) SuperArc® L-56 Mild Steel MIG Wire
- Sample Spool of 0.035" (0.9 mm) Innershield® NR-211-MP Flux-Cored Wire
- 0.025" (0.6 mm) and 0.025 - 0.030" (0.6 - 0.7 mm) Drive Rolls
- 0.030 - 0.045" (0.7 - 1.1 mm) Knurled Drive Roll
- 0.025 - 0.035" (0.6 - 0.9 mm) and 0.035 - 0.045" (0.9 - 1.1 mm) Wire Guides
- Learn-To-Use DVD

Model No.	Mfg. No.	Input Power Voltage/Phase/Hz	Rated Output Current/Voltage/Duty Cycle	Input Current @ Rated Output	Output Range	Price /Each
TTV163	K2471-2	120/1/60	90A/19.5V/20%	20A	30-140 A DC 50-500 ipm WFS (1.3-12.7 m/min) Max. OCV: 33	1270.00

POWER MIG® 180 DUAL WIRE FEED WELDERS

THE PROFESSIONAL'S CHOICESM

- Dual 120 or 208/230 volt input power capability, you can use the same machine to weld at home and generator-driven environments, or choose 208/230 volt input power for shop or out on the job site applications on thicker materials
- Ideal for sheet metal and light frame autobody work, farm or small shop applications
- Diamond Core Technology™ – Delivers a forgiving arc, excellent out-of-position arc action, low spatter and a wide voltage sweet spot at a given wire feed speed for steel, stainless steel or aluminum
- Dual gear-driven cast aluminum drive rolls deliver positive traction
- Patented split wire guides ensure optimal wire alignment and a brass-to-brass gun connection aids critical conductivity
- Large industrial closed-design drive motor improves torque and enhances trouble-free performance
- No hassle tool-less design for input power changes, wire spool mounting, wire drive service and polarity changes
- Spool Gun Ready, remove the standard MIG gun and plug in the economical Magnum® 100SG spool gun **TTU118** (optional) for enhanced aluminum wire feeding performance
- 3-year warranty on machine, 90 days on torch



Processes

Mig
Flux-Cored

Output



Input



Includes:

- Magnum® Pro 100L gun, 10' (3.0 m) cable
- 120V and 230V Input Cables
- Input Cable Bag
- Gas and Gasless Nozzles
- Gun Cable Liner (pre-installed in gun)
- Work Cable and Clamp
- Adjustable Gas Regulator and Hose
- Spindle Adapter
- Sample (0.90 kg) Spool of SuperArc® L-56® Mild Steel MIG Wire
- Sample (0.45 kg) Spool NR®-211-MP Flux-Cored Wire
- 0.025" (0.6 mm) and 0.035" (0.9 mm) Contact Tips
- 0.025 - 0.030" (0.6 - 0.8 mm) and 0.035" (0.9 mm) Drive Rolls
- 0.030 - 0.045" (0.8 - 1.1 mm) Knurled Drive Rolls
- 0.025 - 0.035" (0.6 - 0.9 mm) and 0.045" (1.1 mm) Wire Guides
- Learn-To-Use DVD

Model No.	Mfg. No.	Input Power Voltage/Phase/Hz	Rated Output Current/Voltage/Duty Cycle	Input Current @ Rated Output	Output Range	Wire Feed Speed Range	Price /Each
TTV164	K3018-2	120/1/60	120V: 90A/19.5V/20%	20A	120V: 30-140 Amps DC Max. OCV: 33	50-500 ipm (1.3-12.7 m/min)	1662.00
		208/230/1/60	208V: 130A/17.6V/30% 230V: 130A/20V/30%		230V: 30-180 Amps DC Max. OCV: 34		

POWER MIG® 210 MP MULTI-PROCESS WELDER

ONE POWERFUL MACHINE

- Lightweight and portable-just 40 lbs.
- 210 Amps: The power to tackle any job
- Inverter based technology to weld multiple welding processes* of wire, stick, and TIG
- Dual voltage inputs (120V or 230V), plug into any common power supply
- Intuitive push-and-turn digital controls make setup a breeze
- Advanced options and settings are simple to access
- MIG: Weld up to 3/8" mild or stainless steel or aluminum* up to 3/16"
- Flux-Cored (Self- and Gas-shielded): Tackle the biggest jobs
- DC Stick: Handles up to 5/32" stick electrodes
- DC TIG: Enabled by Touch Start TIG® technology
- 3 year warranty on machine, 90 days on gun and cable assembly

* Additional accessories may be required for different welding processes



LINCOLN
ELECTRIC

THE WELDING EXPERTSSM



Processes

Mig Flux-Cored
DC Stick DC TIG

Output



Input



Includes:

- Magnum® PRO 175L gun, 10' (3.0 m) cable
- 120V and 230V input cables
- Work cable and clamp
- Electrode holder and lead assembly
- Adjustable gas regulator and hose
- Gas and gasless nozzles
- Gun cable liner (pre-installed in gun)
- Spindle adapter
- 2 lb (0.90 kg) spool of SuperArc® L-56® mild steel MIG wire
- 1 lb (0.45 kg) spool Innershield® NR®-211-MP flux-cored wire
- 0.025" (0.6 mm) and 0.035" (0.9 mm) contact tips
- 0.025" - 0.030" (0.6 - 0.8 mm) and 0.035" (0.9 mm) drive rolls
- 0.030" - 0.045" (0.8 - 1.1 mm) knurled drive rolls
- 0.025" - 0.035" (0.6 - 0.9 mm) and 0.045" (1.1 mm) wire guides

Model No.	Mfg. No.	Input Power Voltage/Phase/Hertz	Rated Output Current/Voltage/Duty Cycle	Input Current @ Rated Output	Output Range	Wire Feed Speed Range	Price /Each
TTV220	K3963-1	120/1/60	120V: 100A/19.0V/40%	15A	20-140A DC Max. OCV: 56	50-500 ipm (1.3-12.7 m/min)	1980.00
		230/1/60	230V: 200A/24V/25%	14.7A	230V: 20-220A DC Max. OCV: 56		

POWER MIG® 256 WIRE FEED WELDERS

THE PROFESSIONAL'S CHOICE™

- The Power MIG® 256 sets the standard for MIG and flux-cored welding in light industrial job shop fabrication, maintenance or repair work
- Diamond Core Technology™ delivers a forgiving arc, excellent out-of-position arc stability, low spatter and a wide voltage sweet spot at a given wire feed speed for steel, stainless steel or aluminum
- Maxtrac® cast aluminum industrial wire drive features dual driven rolls, regulated wire feed speed control, brass-to-brass connections and 100% wire supporting split wire guide system
- Digital meters for set up, meters display your preset voltage and wire feed speed
- Magnum® Pro gun and cable 15' (4.5 m) makes it easy to reach your work
- Copper Plus™ contact tips features larger tip diameter and mass improves heat dissipation to increase tip life
- Spool gun ready for the premium Magnum® 250LX gun (TTU319) and spool gun capable with the Magnum® SG (TTU318), requires adapter
- 115V auxiliary receptacle to power a grinder or other auxiliary equipment
- All-metal case front
- 3-year warranty on machine, 90 days on torch



LINCOLN
ELECTRIC

THE WELDING EXPERTSSM



Processes

Mig Flux-Cored

Output



Input



Includes:

- Magnum® Pro gun and cable 15' (4.5 m)
- Coil Claw™ Cable Management system keeps your workstation organized
- Convenient top-mounted gun expendables tray

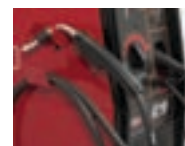

Coil Claw

Model No.	Mfg. No.	Input Power Voltage/Phase/Hertz	Rated Output Current/Voltage/Duty Cycle**	Input Current @ Rated Output	Output Range	Price /Each
TTV124	K3068-1	208/230/1/60	250A/26V/40%	56/52A***	30-300 A 50-700 ipm WFS (1.3-17.7 m/min) Max. OCV: 40V	4085.00
TTV162*	K3068-2	230/460/575/1/60	250A/26V/40%	50/24/19A	30-300 A 50-700 ipm WFS (1.3-17.7 m/min) Max. OCV: 40V	4222.00

* Does not include input cable ** Cannot be powered by an engine-driven welder

*** Input current is at the rated output with the 115V auxiliary receptacle also drawing 15 amps

CALL US FOR OPTIONAL ACCESSORIES FOR LINCOLN ELECTRIC WELDING MACHINES

OFFICE PRODUCTS

INSTRUMENTS, SCALES & ELECTRICAL

SHIPPING & PACKAGING

TOOLS & EQUIPMENT

WELDING & METALWORKING

SAFETY EQUIPMENT & SUPPLIES

JANITORIAL & MAINTENANCE

MATERIAL HANDLING & STORAGE

MIG GUNS & ACCESSORIES



MIG GUNS

- Recommended for applications using solid and flux core wire
- Guns are complete with 15' cable length
- A complete selection of replacement parts for most brands of guns is available
- Contact us for pricing on guns with different amperage ratings or cable lengths

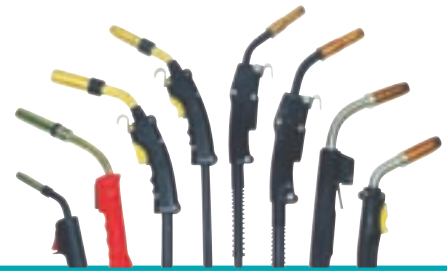

BERNARD® STYLE REPLACEMENT AIR-COOLED MIG GUNS

200 AMPS

Rating:

- 200 Amps CO₂ @ 100% duty cycle
- 150 Amps mixed gas @ 100% duty cycle
- Wire capacity: 0.023" - 0.045"

300 AMPS

Rating:

- 300 Amps CO₂ @ 100% duty cycle
- 250 Amps mixed gas @ 100% duty cycle
- Wire capacity: 0.030" - 0.062"

350 AMPS

Rating:

- 350 Amps CO₂ @ 100% duty cycle
- 250 Amps mixed gas @ 100% duty cycle
- Wire capacity: 0.030" - 0.062"

400 AMPS

Rating:

- 400 Amps CO₂ @ 100% duty cycle
- 300 Amps mixed gas @ 100% duty cycle
- Wire capacity: 0.035" - 5/64"



Model No.	Mfg. No.	Feeder Plug	Price /Each
200 AMPS			
379-4395	B2-4215A	Bernard DP	220.00
379-1101	B2-4215AM	Miller DP	221.00
379-4510	B2-4215AE	Euro DP	208.00
379-4201	B2-4215AL	Lincoln DP	220.00
TTT009	B2-4215AWM	Lincoln Wirematic	220.00
TTT010	B2-4215AT	Tweco DP	220.00
300 AMPS			
NT172	B2-4315A	Bernard DP	244.00
NT174	B2-4315AM	Miller DP	206.00
NT173	B2-4315AE	Euro DP	208.00
NT204	B2-4315AL	Lincoln DP	208.00
TTT011	B2-4315AWM	Lincoln WM 250	208.00
NT175	B2-4315AT	Tweco DP	208.00

Model No.	Mfg. No.	Feeder Plug	Price /Each
350 AMPS			
379-4570	B2-43515A	Bernard DP	271.00
379-1113	B2-43515AM	Miller DP	236.00
TTT012	B2-43515AE	Euro DP	255.00
379-4223	B2-43515AL	Lincoln DP	236.00
TTT013	B2-43515AWM	Lincoln Wirematic	236.00
379-4920	B2-43515AT	Tweco DP	236.00
400 AMPS			
TW978	B2-4415A	Bernard DP	277.00
TW983	B2-4415AM	Miller DP	236.00
TW979	B2-4415AE	Euro DP	244.00
TW981	B2-4415AL	Lincoln DP	236.00
TW984	B2-4415AT	Tweco DP	236.00

BERNARD® STYLE CONSUMABLES



Contact Tip



Long Contact Tip



Model No.	Mfg. No.	Description	Size"	200 Amps	300 Amps	350 Amps	400 Amps	Price /Each
NT183	B7497	Contact Tip	0.023	X	X	X		0.63
NT179	B7488	Contact Tip	0.030	X	X	X		0.63
NT180	B7489	Contact Tip	0.035	X	X	X	X	0.63
PB052	B7496	Contact Tip	0.040	X	X	X	X	0.63
NT181	B7490	Contact Tip	0.045	X	X	X	X	0.63
PB054	B7498	Contact Tip	0.052	X	X	X	X	0.63
NT182	B7491	Contact Tip	1/16	X	X	X	X	0.63
PB048	B7492	Contact Tip	5/64				X	0.63
PB050	B7494	Contact Tip	7/64				X	0.63
PB043	B1597	Contact Tip, Long	0.023	X	X	X		0.63
TTT074	B1588	Contact Tip, Long	0.030	X	X	X		0.90
TW993	B1589	Contact Tip, Long	0.035	X	X	X	X	0.90
PB042	B1596	Contact Tip, Long	0.040	X	X	X	X	0.90
TW994	B1590	Contact Tip, Long	0.045	X	X	X	X	0.90
PB044	B1598	Contact Tip, Long	0.052	X	X	X	X	0.63
TW995	B1591	Contact Tip, Long	1/16	X	X	X	X	0.90
TW996	B1592	Contact Tip, Long	5/64				X	2.14
TW997	B1593	Contact Tip, Long	3/32				X	0.90
TW998	B1594	Contact Tip, Long	7/64				X	2.14
379-1124	B4281	Contact Tip, Tapered	0.035	X	X	X		1.19
TTT133	B4282	Contact Tip, Tapered	0.045	X	X	X		1.99
TTT134	B4283	Contact Tip, Tapered	0.052	X	X	X		1.99
TTT132	B4280	Contact Tip, Tapered	1/16	X	X	X		1.99

Note: All reference to genuine manufacturer's equipment numbers and/or trade names or trademarks are for identification and convenience only. The trademarks and trade names are the property of their respective owners.

Continued on next page

MIG GUNS & ACCESSORIES

BERNARD® STYLE CONSUMABLES

Continued from previous page



Nozzles



Gas Diffusers



Trigger Assembly



Liner Assembly

Model No.	Mfg. No.	Description	Size"	200 Amps	300 Amps	350 Amps	400 Amps	Price /Each
PB063	B4491	Nozzle, Brass, Standard	3/4 I.D.			X	X	7.26
PB064	B4591	Nozzle, Brass	3/4 I.D.			X		7.81
NT177	B4391	Nozzle, Brass	5/8 I.D.	X	X			4.88
NT178	B4393	Nozzle, Copper	5/8 I.D.	X	X			6.82
BZ934	B4392	Nozzle, Brass, Standard	1/2 I.D.	X	X			12.20
379-4224	B4394	Nozzle, Copper	1/2 I.D.	X	X			6.82
PB059	B4492	Nozzle, Brass	9/16 I.D.			X	X	7.26
PB060	B4592	Nozzle, Copper	9/16 I.D.			X	X	7.74
379-1125	B4295	Nozzle, Brass	11/32 I.D.	X	X			8.36
NT176	B4335	Head Assembly, Standard		X	X			4.51
PB057	B4435	Head Assembly, Standard				X	X	4.73
379-1231	B7126	O-Ring		X	X			0.40
379-1232	B7127	O-Ring				X	X	0.40
379-1140	B4323R	Silicone Cap, Standard		X	X			1.32
379-1186	B4423R	Silicone Cap, Standard				X	X	1.43
379-1223	B4786	Body Tube Assembly		X	X			15.90
TTT137	B4790	Body Tube Assembly				X	X	15.90
379-1222	B4780	Insulator Hex Nut		X	X	X	X	1.22
379-1225	B5662	Trigger Assembly		X	X	X		4.52
379-1178	B4422	Trigger Assembly					X	25.20
379-1127	B43015	Liner Assembly, 15'	0.023 - 0.030	X	X			8.62
379-1135	B43115	Liner Assembly, 15', Standard	0.035 - 0.045	X	X			6.78
379-1139	B43215	Liner Assembly, 15'	0.045 - 0.062	X	X			6.82
379-5840	B43115X	Liner Assembly, Teflon®, 15'	0.035 - 3/64	X	X	X		13.40
379-1170	B44115	Liner Assembly, 15'	0.035 - 0.045			X	X	6.78
379-1175	B44215	Liner Assembly, 15'	0.045 - 0.062			X	X	6.78
379-1188	B44315	Liner Assembly, 15'	5/64				X	8.88

MILLER® STYLE REPLACEMENT AIR-COOLED MIG GUNS

- Guns are complete with 15' cable length

250 AMPS

Rating:

- 250 Amps CO₂ @ 100% duty cycle
- 250 Amps mixed gas @ 60% duty cycle
- Wire capacity: 0.030" - 0.045"



379-M169-715



379-1050



GUNS

Model No.	Mfg. No.	Amps	Feeder Plug	Price /Each
NT206	M169-598	250	Miller DP	345.00

CONSUMABLES

Model No.	Mfg. No.	Description	Size"	150 Amps	250 Amps	Price /Each
NT168	M087-299	Contact Tip	0.023	X	X	0.43
NT165	M000-067	Contact Tip	0.030	X	X	0.43
NT166	M000-068	Contact Tip	0.035	X	X	0.43
NT167	M000-069	Contact Tip	0.045	X	X	0.43
379-M169-715	M169-715	Nozzle	1/2	X		5.17
NT169	M169-724	Nozzle, 1/8" Tip Recess	1/2		X	8.38
NT170	M169-725	Nozzle, 1/8" Tip Recess	5/8		X	8.38
379-1050	M169-726	Nozzle, Flush	5/8		X	8.42
TTT177	M169-727	Nozzle, 1/8" Tip Stickout	5/8		X	8.51
379-1055	M169-729	Nozzle Retainer			X	4.30
TTT178	M170-467	Replacement Retaining Ring		X		2.09
TTT179	M170-468	Replacement O-Ring			X	0.41
TTT180	M169-716	Retaining Head		X		3.89
TTT181	M170-470	Replacement Retaining Ring		X		2.09
TTT182	M170-471	Replacement O-Ring		X		0.41
TTT183	M169-717	Shock Washer		X		4.23
TTT184	M169-730	Shock Washer			X	2.95
TTT185	M169-718	Gooseneck, 45°		X		38.10
TTT186	M169-731	Gooseneck, 45°			X	42.50
NT171	M169-728	Gas Diffuser			X	1.84
TTT188	M194-010	Liner Conduit, 15'	0.023 - 0.025	X	X	6.89
TTT189	M194-011	Liner Conduit, 15'	0.030 - 0.035	X	X	6.82
TTT190	M194-012	Liner Conduit, 15'	0.035 - 0.045	X	X	6.82
TTT191	M194-014	Liner Conduit, 15', Aluminum	0.035 - 3/64		X	35.90

Note: All reference to genuine manufacturer's equipment numbers and/or trade names or trademarks are for identification and convenience only. The trademarks and trade names are the property of their respective owners.

OFFICE PRODUCTS

INSTRUMENTS, SCALES & ELECTRICAL

SHIPPING & PACKAGING

TOOLS & EQUIPMENT

WELDING & METALWORKING

SAFETY EQUIPMENT & SUPPLIES

JANITORIAL & MAINTENANCE

MATERIAL HANDLING & STORAGE

1095

MIG GUNS & ACCESSORIES

TWECO® STYLE REPLACEMENT AIR-COOLED MIG GUNS

- Guns are complete with 15' cable length

160 AMPS

Rating:

- 160 Amps CO₂ @ 80% duty cycle
- 100 Amps mixed gas @ 80% duty cycle
- Wire capacity: 0.023" - 0.045"

200 AMPS

Rating:

- 200 Amps CO₂ @ 100% duty cycle
- 150 Amps mixed gas @ 100% duty cycle
- Wire capacity: 0.023" - 0.045"

300 AMPS

Rating:

- 300 Amps CO₂ @ 100% duty cycle
- 200 Amps mixed gas @ 100% duty cycle
- Wire capacity: 0.030" - 0.062"

400 AMPS

Rating:

- 400 Amps CO₂ @ 100% duty cycle
- 300 Amps mixed gas @ 100% duty cycle
- Wire capacity: 0.030" - 5/64"



MIG GUN



379-1265

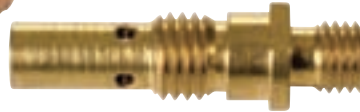

379-1570



379-1455



379-1488

CONSUMABLES

GUNS

Model No.	Mfg. No.	Feeder Plug	Price /Each
160 AMPS			
TTT029	C35-15	No Gun Plug	211.00
TTT030	CC35-15	Century DP	211.00
TTT031	CL35-15	Lincoln SP100-185 DP	190.00
TTT032	CWM35-15	Lincoln Wirematic	211.00
TTT033	CSP35-15	Lincoln SP150/200DP	190.00
TTT034	CM35-15	Miller DP	190.00
TTT035	CT35-15	Tweco DP	190.00
TTT036	CX35-15	Euro DP	190.00
200 AMPS			
TTT037	C215-3035	Tweco Plug	172.00
TTT038	CM215-3035	Miller DP	172.00
TTT039	CL215-3035	Lincoln "LN" DP	172.00
TTT040	CLPM215-3035	Lincoln Power MIG	172.00
TTT042	CX215-3035	Euro DP	157.00
300 AMPS			
NT189	C315-3545	Tweco Plug	231.00
NT192	CM315-3545	Miller DP	231.00
NT207	CL315-3545	Lincoln "LN" DP	238.00
NT208	CH315-3545	Hobart DP	227.00
NT209	CX315-3545	Euro DP	227.00
400 AMPS			
379-1590	C415-3545	Tweco Plug	232.00
379-1680	CM415-3545	Miller DP	239.00
TTT043	CL415-3545	Lincoln "LN" DP	239.00
TTT044	CH415-3545	Hobart DP	239.00
TTT045	CX415-3545	Euro DP	239.00

Note: All reference to genuine manufacturer's equipment numbers and/or trade names or trademarks are for identification and convenience only. The trademarks and trade names are the property of their respective owners.

CONSUMABLES

Model No.	Mfg. No.	Description	Size"	Price /Each
160 AMPS				
379-1265	C11-23	Contact Tip	0.023	0.37
379-1270	C11-30	Contact Tip	0.030	0.37
379-1275	C11-35	Contact Tip, Standard	0.035	0.37
TTT224	C11-40	Contact Tip	0.040	0.37
379-1280	C11-45	Contact Tip	0.045	0.37
379-1285	C11H-35	Contact Tip, Heavy-Duty	0.035	0.46
TTT227	C11H-45	Contact Tip, Heavy-Duty	0.045	0.46
379-4209	C11T-23	Contact Tip, Tapered	0.023	0.46
TTT228	C11T-30	Contact Tip, Tapered	0.030	0.46
TTT229	C11T-35	Contact Tip, Tapered	0.035	0.46
TTT230	C11T-40	Contact Tip, Tapered	0.040	0.46
TTT231	C11T-45	Contact Tip, Tapered	0.045	0.46
379-1455	C21-50	Nozzle, Standard	1/2 I.D.	5.66
TTT232	C21-50-F	Nozzle, Flush	1/2 I.D.	5.74
379-1460	C21-62	Nozzle	5/8 I.D.	3.85
TTT233	C21-62-F	Nozzle, Flush	5/8 I.D.	5.74
379-1445	C21-37	Nozzle	3/8 I.D.	5.74
TTT234	C21-37-F	Nozzle, Flush	3/8 I.D.	5.74
379-1465	C21T-37	Nozzle Tapered	3/8 I.D.	5.74
TTT235	C21T-37-F	Nozzle Tapered, Flush	3/8 I.D.	5.08
379-1570	C35-50	Gas Diffuser, Standard		1.92
TTT236	C35-60-45	Conductor Tube, 45°		11.30
TTT237	C35-60-60	Conductor Tube, 60°, Standard		11.30
TTT238	C35-60-180	Conductor Tube, 180°		11.30
379-1488	C23-40-15	Liner Assembly, 15'	0.023	6.65
379-1569	C35-40-15	Liner Assembly, 15', Standard	0.035	6.65
TTT239	C45-40-15	Liner Assembly, 15'	0.045	6.89
TTT240	C35TF-40-10	Liner Assembly, Teflon® 10'	0.035	26.90
TTT241	C35TF-40-15	Liner Assembly, Teflon® 15'	0.035	26.90
TTT242	C45TF-40-10	Liner Assembly, Teflon® 10'	0.045	15.80
TTT243	C45TF-40-15	Liner Assembly, Teflon® 15'	0.045	15.80

Continued on next page

MIG WIRE CLEANING PADS

- Designed for use on all MIG wire feeders
- Removes dust and dirt from the wire prior to wire entry into the liner conduit
- Use of wire feed pads can decrease the coefficient of friction in the liner as much as 50%-60% and reduce erratic feed and burn backs
- Treated pads can be used on all alloyed wires except aluminum
- **Sold per package**



Model No.	Qty/Pkg.	Price/Each
720-1000-KIT	6	9.31
720-1010-KIT	24	37.20

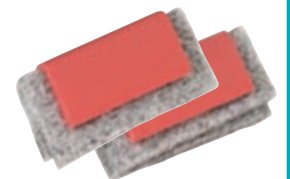

TWECO® CONSUMABLES

Continued from previous page



Model No.	Mfg. No.	Description	Size"	200 Amps	300 Amps	400 Amps	Price /Each
200, 300 & 400 AMPS							
NP602	C14-23	Contact Tip	0.023	X			0.46
NP603	C14-30	Contact Tip	0.030	X	X		0.46
NP604	C14-35	Contact Tip, Standard	0.035	X	X	X	0.46
NP605	C14-40	Contact Tip	0.040	X	X	X	0.46
NP606	C14-45	Contact Tip	0.045	X	X	X	0.46
NP608	C14A-364	Contact Tip, Aluminum	3/64	X	X	X	0.46
NP607	C14-52	Contact Tip	0.052		X	X	0.46
NP601	C14-116	Contact Tip	1/16		X	X	0.46
TTT244	C14-564	Contact Tip	5/64			X	0.46
NP611	C14H-35	Contact Tip, Heavy-Duty	0.035	X	X	X	0.60
NP612	C14H-40	Contact Tip, Heavy-Duty	0.040	X	X	X	0.60
NP613	C14H-45	Contact Tip, Heavy-Duty	0.045	X	X	X	0.60
NP609	C14AH-364	Contact Tip, Heavy-Duty, Aluminium	3/64	X	X	X	0.73
NP614	C14H-52	Contact Tip, Heavy-Duty	0.052		X	X	0.60
NP610	C14H-116	Contact Tip, Heavy-Duty	1/16		X	X	0.60
NP615	C14H-564	Contact Tip, Heavy-Duty	5/64			X	0.60
TTT245	C14T-23	Contact Tip, Tapered	0.023	X			0.50
TTT246	C14T-30	Contact Tip, Tapered	0.030	X	X		0.50
379-1395	C14T-35	Contact Tip, Tapered	0.035	X	X	X	0.50
TTT247	C14T-40	Contact Tip, Tapered	0.040	X	X	X	0.50
379-1400	C14T-45	Contact Tip, Tapered	0.045	X	X	X	0.50
TTT248	C14T-52	Contact Tip, Tapered	0.052		X	X	0.50
TTT249	C14T-116	Contact Tip, Tapered	1/16			X	0.50
379-1475	C22-50	Nozzle, Adjustable, Standard	1/2 I.D.	X			2.21
379-1480	C22-62	Nozzle, Adjustable	5/8 I.D.	X			2.62
NP621	C24A-50	Nozzle, Adjustable	1/2 I.D.		X	X	3.29
NP622	C24A-62	Nozzle, Adjustable, Standard	5/8 I.D.		X	X	3.26
NP623	C24A-75	Nozzle, Adjustable	3/4 I.D.		X	X	3.29
TTT250	C22-37-SS	Nozzle, Short Stop	3/8 I.D.	X			2.62
379-4960	C22-50-SS	Nozzle, Short Stop	1/2 I.D.	X			2.62
TTT251	C22-62-SS	Nozzle, Short Stop	5/8 I.D.	X			2.62
NP620	C24A-37-SS	Nozzle, Short Stop	3/8 I.D.		X	X	3.29
NP697	C24A-50-SS	Nozzle, Short Stop	1/2 I.D.		X	X	3.49
NP698	C24A-62-SS	Nozzle, Short Stop	5/8 I.D.		X	X	3.49
NP699	C24A-75-SS	Nozzle, Short Stop	3/4 I.D.		X	X	3.49
379-1485	C22T-37-SS	Nozzle, Tapered, Short Stop	3/8 I.D.	X			2.62
NP700	C24AT-37-SS	Nozzle, Tapered, Short Stop	3/8 I.D.		X	X	3.49
NP616	C23-37	Nozzle, Self Insulated	3/8 I.D.	X	X	X	7.81
NP617	C23-50	Nozzle, Self Insulated	1/2 I.D.	X	X	X	7.81
NP618	C23-62	Nozzle, Self Insulated	5/8 I.D.	X	X	X	7.81
TTT252	C23-75	Nozzle, Self Insulated	3/4 I.D.		X	X	7.81
379-1500	C23T-37	Nozzle, Self Insulated, Tapered	3/8 I.D.	X	X	X	8.22
NP624	C24CT-37-S	Nozzle, Coarse Thread	3/8 I.D.	X	X	X	5.21
NP625	C24CT-50-S	Nozzle, Coarse Thread	1/2 I.D.	X	X	X	5.21
NP626	C24CT-62-S	Nozzle, Coarse Thread	5/8 I.D.	X	X	X	5.21
NP627	C24CT-75-S	Nozzle, Coarse Thread	3/4 I.D.		X	X	5.21
NP629	C34CT	Nozzle Insulator, Fixed Nozzle		X	X	X	7.87
379-1550	C32	Nozzle Insulator, Standard		X			1.09
NP628	C34A	Nozzle Insulator, Standard			X	X	1.09
379-1630	C52	Gas Diffuser, Standard		X			3.25
NT191	C54A	Gas Diffuser, Standard			X	X	1.64
379-1635	C52FN	Gas Diffuser for Fixed Nozzle		X			3.24
379-1595	C42-3035-15	Liner Assembly, 15', Standard	0.030 - 0.035	X			6.40
NP631	C44-3545-15	Liner Assembly, 15', Standard	0.035 - 0.045		X	X	6.78
379-1600	C42-4045-15	Liner Assembly, 15'	0.040 - 0.045	X			6.40
NP630	C44-116-15	Liner Assembly, 15'	0.062		X	X	6.78
NP706	C44-564-15	Liner Assembly, 15'	5/64			X	6.82
TTT267	C42-3035-25	Liner Assembly, 25'	0.030 - 0.035	X			13.40
TTT268	C42-4045-25	Liner Assembly, 25'	0.040 - 0.045	X			13.40
379-1618	C44-3545-25	Liner Assembly, 25'	0.035 - 0.045		X	X	15.30
379-1610	C44-116-25	Liner Assembly, 25'	0.062		X	X	15.30
TTT269	C44-564-25	Liner Assembly, 25'	5/64			X	13.40
379-7010	C42N-3545-15	Liner Assembly, Nylon, 15'	0.035 - 0.045	X			17.70
NP633	C44N-3545-15	Liner Assembly, Nylon, 15'	0.035 - 0.045		X	X	15.80
NP632	C44N-116-15	Liner Assembly, Nylon, 15'	0.062		X	X	15.80



NP611



379-1400



379-1500

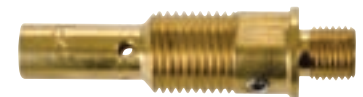

379-1635



379-1600

Note: All reference to genuine manufacturer's equipment numbers and/or trade names or trademarks are for identification and convenience only. The trademarks and trade names are the property of their respective owners.

CENTERFIRE™ SERIES NOZZLES, TIPS & DIFFUSERS

- No tools required to replace tip or nozzle
- "Drop-In" tip with no threads means quick change after burnback, reducing down time
- Large diameter tip base and tapered seat provide better electrical conductivity and heat transfer
- Spatter shield within nozzle protects diffuser and gives smoother, less turbulent gas flow
- Solid, concentric relationship between tip and nozzle keeps tip centered even after hard use... and abuse
- Threaded nozzle holds tip fixed at 1/8" or 1/4" recess, flush, or 1/8" stick out
- Compatible with all standard air-cooled Bernard® guns
- Complete family of tips and nozzles is available to meet most of your welding needs

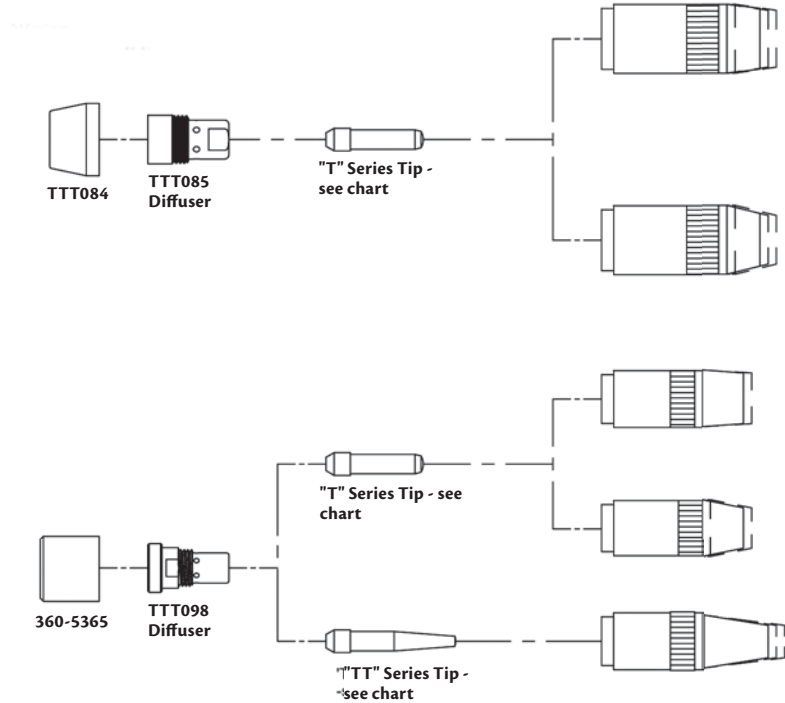

- TTU273** Copper Nozzle (3/4" I.D., Flush Tip)
- TTU037** Copper Nozzle (3/4" I.D., 1/8" Tip Recess)
- TTT092** Copper Nozzle (3/4" I.D., 1/4" Tip Recess)
- TTT093** Brass Nozzle (3/4" I.D., 1/8" Tip Recess)
- TTT094** Brass Nozzle (3/4" I.D., 1/4" Tip Recess)
- TTU274** Copper Nozzle (5/8" I.D., Flush Tip)
- TTU038** Copper Nozzle (5/8" I.D., 1/8" Tip Recess)
- TTT095** Copper Nozzle (5/8" I.D., 1/4" Tip Recess)
- TTT096** Brass Nozzle (5/8" I.D., 1/8" Tip Recess)
- TTT097** Brass Nozzle (5/8" I.D., 1/4" Tip Recess)
- TTT104** Brass Nozzle (5/8" I.D., 1/8" Tip Recess)
- TTT106** Brass Nozzle (1/2" I.D., Flush Tip)
- TTT105** Brass Nozzle (1/2" I.D., 1/8" Tip Recess)
- TTU275** Brass Nozzle (3/8" I.D., Flush Tip)
- TTT107** Brass Nozzle (3/8" I.D., 1/8" Tip Recess)
- TTU276** Brass Nozzle (3/8" I.D., 1/8" Tip Extension)

T SERIES		"T" Series Tip		
Model No.	Mfg. No.	Description	Wire Size"	Price /Each
DIFFUSERS				
TTT084	10012	Insulator Cap	-	8.87
TTT085	D-1	Diffuser	-	16.10
CONTACT TIPS				
TTT086	T-030	1.50" Long	0.030	1.95
TTT087	T-035	1.50" Long	0.035	1.95
TTT088	T-039	1.50" Long	0.039	1.95
TTT089	T-045	1.50" Long	0.045	1.95
TTT090	T-052	1.50" Long	0.052	1.95
TTT091	T-062	1.50" Long	1/16	1.95
NOZZLES				
TTU273	N-3400C	Copper, Flush Tip	3/4 I.D.	20.30
TTU037	N-3418C	Copper, 1/8" Tip Recess	3/4 I.D.	20.30
TTT092	N-3414C	Copper, 1/4" Tip Recess	3/4 I.D.	20.30
TTT093	N-3418B	Brass, 1/8" Tip Recess	3/4 I.D.	19.70
TTT094	N-3414B	Brass, 1/4" Tip Recess	3/4 I.D.	19.70
TTU274	N-5800C	Copper, Flush Tip	5/8 I.D.	20.30
TTU038	N-5818C	Copper, 1/8" Tip Recess	5/8 I.D.	20.30
TTT095	N-5814C	Copper, 1/4" Tip Recess	5/8 I.D.	20.30
TTT096	N-5818B	Brass, 1/8" Tip Recess	5/8 I.D.	19.70
TTT097	N-5814B	Brass, 1/4" Tip Recess	5/8 I.D.	19.70

TT SERIES		"TT" Series Tip		
Model No.	Mfg. No.	Description	Wire Size"	Price /Each
DIFFUSERS				
360-5365	4323R	Insulator Cap	-	8.87
TTT098	DS-1	Diffuser	-	16.10
CONTACT TIPS				
TTT099	TT-030	2.00" Long	0.030	2.39
TTT100	TT-035	2.00" Long	0.035	2.39
TTT101	TT-045	2.00" Long	0.045	2.39
TTT102	TT-052	2.00" Long	0.052	2.39
TTT103	TT-062	2.00" Long	1/16	2.39
NOZZLES				
TTT104	NS-5818B	Brass, 1/8" Tip Recess	5/8 I.D.	16.00
TTT106	NS-1200B	Brass, Flush Tip	1/2 I.D.	16.00
TTT105	NS-1218B	Brass, 1/8" Tip Recess	1/2 I.D.	16.00
TTU275	NST-3800B	Brass, Flush Tip	3/8 I.D.	18.20
TTT107	NST-3818B	Brass, 1/8" Tip Recess	3/8 I.D.	18.20
TTU276	NST-38XTB	Brass, 1/8" Tip Extension	3/8 I.D.	18.20



aurora tools[®]



***Canada's Best Value
in Industrial Tools***

TIG TORCHES & ACCESSORIES



Innovative "WP" silicone rubber insulated TIG welding torches

AIR (GAS) COOLED TORCHES

WP-24

Small, Lightweight

- Ideal for intricate work
- Reaches into tight places
- Handle mounted gas control valve
- Feather weight, but well balanced and durable
- Torch body head: 60° angle
- Torch length: 7 1/2"
- Max capacity: 80 A
- Handle style: Ribbed



366-4669

WP-9

Versatile, Lightweight for Thin Gauge Materials

- Quick-release tungsten adjustment
- Torch body head: 70° angle
- Torch length: 7"
- Max capacity: 125 A
- Handle style: Ribbed

Description	Amps	Max. Angle	Gas Valve	Power Cable	Accessory Kit**
WP-24 TORCH BODY					
W/insulating gasket	80	60°	No		AK-5
W/insulating gasket and flexible head	80	60°	No		AK-5
W/insulating gasket, gas valve and flexible head	80	60°	Slide		AK-5
WP-24 TORCH PACKAGES - TORCH BODY, HANDLE, 25' POWER CABLE					
W/insulating gasket	80	60°	No	1-Piece Rubber Jacketed	AK-5
W/insulating gasket and flexible head	80	60°	No	1-Piece Rubber Jacketed	AK-5
W/insulating gasket, gas valve and flexible head	80	60°	Slide	1-Piece Rubber Jacketed	AK-5
WP-9 TORCH BODY					
W/cup gasket	125	70°	No		AK-1
W/cup gasket and gas valve	125	70°	Knob & Stem		AK-1
W/cup gasket and flexible head	125	70°	No		AK-1
W/cup gasket, gas valve and flexible head	125	70°	Knob & Stem		AK-1
WP-9 TORCH PACKAGES - TORCH BODY, HANDLE, MEDIUM BACK CAP, 25' POWER CABLE					
W/cup gasket	125	70°	No	1-Piece Rubber Jacketed	AK-1
W/cup gasket and gas valve	125	70°	Knob & Stem	1-Piece Rubber Jacketed	AK-1
W/cup gasket and flexible head	125	70°	No	1-Piece Rubber Jacketed	AK-1
W/cup gasket, gas valve and flexible head	125	70°	Knob & Stem	1-Piece Rubber Jacketed	AK-1
WP-17 TORCH BODY					
W/cup gasket	150	70°	No		AK-2
W/cup gasket and gas valve	150	70°	Knob & Stem		AK-2
W/cup gasket and flexible head	150	70°	No		AK-2
W/cup gasket, gas valve and flexible head	150	70°	Knob & Stem		AK-2
WP-17 TORCH PACKAGES - TORCH BODY, LONG BACK CAP, HANDLE, 25' POWER CABLE					
W/cup gasket	150	70°	No	2-Piece	AK-2
W/cup gasket and gas valve	150	70°	Knob & Stem	2-Piece	AK-2
W/cup gasket	150	70°	No	1-Piece Rubber Jacketed	AK-2
W/cup gasket and gas valve	150	70°	Knob & Stem	1-Piece Rubber Jacketed	AK-2
W/cup gasket and flexible head	150	70°	No	1-Piece Rubber Jacketed	AK-2
W/cup gasket, gas valve and flexible head	150	70°	Knob & Stem	1-Piece Rubber Jacketed	AK-2
WP-26 TORCH BODY					
W/cup gasket	200	70°	No		AK-3
W/cup gasket and gas valve	200	70°	Knob & Stem		AK-3
W/cup gasket and flexible head	200	70°	No		AK-3
W/cup gasket, gas valve and flexible head	200	70°	Knob & Stem		AK-3
WP-26 TORCH PACKAGES - TORCH BODY, LONG BACK CAP, HANDLE, 25' POWER CABLE					
W/cup gasket	200	70°	No	2-Piece	AK-3
W/cup gasket and gas valve	200	70°	Knob & Stem	2-Piece	AK-3
W/cup gasket	200	70°	No	1-Piece Rubber Jacketed	AK-3
W/cup gasket and gas valve	200	70°	Knob & Stem	1-Piece Rubber Jacketed	AK-3
W/cup gasket and flexible head	200	70°	No	1-Piece Rubber Jacketed	AK-3
W/cup gasket, gas valve and flexible head	200	70°	Knob & Stem	1-Piece Rubber Jacketed	AK-3

** See page 1109 for accessory kits

TIG TORCHES & ACCESSORIES

WP-17

High Capacity for Thin to Medium Gauge Materials

- Compact and durable for field welding applications
- Ribbed handle for comfort and cool operation
- Finger tip gas control valve on WP-17V
- Torch body head: 70° angle
- Torch length: 7 3/4"
- Max capacity: 150 A
- Handle style: Ribbed



WP-17

WP-26

Maximum Capacity for Continuous Heavy-Duty Use

- Heavy copper construction for rugged field work
- Torch body head: 70° angle
- Torch length: 8 1/2"
- Max capacity: 200 A
- Handle style: Ribbed



WP-26



WELDCRAFT



Model No.	Weldcraft Mfg. No.	Price /Each	Model No.	Weldmate Mfg. No.	Price /Each	Model No.	C-K Mfg. No.	Price /Each
366-4669	WP-24	95.50				820-1590	CK80	57.10
TTT271	WP-24F	155.00				820-1615	CK90	90.40
TTT272	WP-24FV	211.00				820-2070	CK90V	124.00
TTT273*	WP-24-25-R	254.00						
TTT275*	WP-24F-25-R	344.00	363-1945	VT-9F-25-R	160.00			
TTT276*	WP-24FV-25-R	370.00	363-1970	VT-9FV-25-R	205.00			
366-4249	WP-9	67.10				820-2205	CK130V	95.20
366-4378	WP-9V	104.00						
366-4278	WP-9F	133.00						
366-4300	WP-9FV	168.00						
366-4402*	WP-9-25-R	232.00				820-2270	CK1325H RG	174.00
366-4399*	WP-9V-25-R	244.00				820-2105	CK1325VH RG	215.00
TTT277*	WP-9F-25-R	275.00						
366-4324*	WP-9FV-25-R	311.00				820-2090	CK1325VH FX	246.00
366-4438	WP-17	70.50				820-1115	CK150 RG	51.40
366-4513	WP-17V	111.00				820-1125	CK150V RG	74.20
366-4462	WP-17F	138.00				820-1110	CK150 FX	89.40
366-4486	WP-17FV	176.00				820-1120	CK150V FX	112.00
NP473	WP-17-25-2	424.00				820-1200	CK1525VN RG	201.00
NP474	WP-17V-25-2	574.00				820-1165	CK1525H RG	160.00
366-4459*	WP-17-25-R	235.00				820-1185	CK1525VH RG	201.00
366-4540*	WP-17V-25-R	254.00						
366-4483*	WP-17F-25-R	284.00				820-1180	CK1525VH FX	242.00
366-4510*	WP-17FV-25-R	319.00						
366-4744	WP-26	80.50	363-1280	VT-26	55.80	820-1280	CK210-R / CK26 RG	66.60
366-4822	WP-26V	133.00	363-1640	VT-26V	82.30	820-1290	CK210V-R / CK26V RG	95.20
366-4774	WP-26F	177.00	363-2025	VT-26F	95.20	820-1275	CK210-F / CK26 FX	114.00
366-4795	WP-26FV	250.00	363-2050	VT-26FV	123.00	820-1285	CK210V-F / CK26V FX	143.00
NP476	WP-26V-25-2	349.00	363-1220	VT-26-25-2	207.00			
366-4765*	WP-26-25-R	323.00	363-1455	VT-26V-25-2	226.00	820-1355	CK2125H-R / CK26-25-R RG	240.00
366-4843*	WP-26V-25-R	292.00	363-1435	VT-26-25-R	207.00	820-1390	CK2125VH-R / CK26V-25-R RG	236.00
366-4792*	WP-26F-25-R	408.00	363-1460	VT-26V-25-R	226.00	820-1350	CK2125H-F / CK26-25-R FX	283.00
366-4819*	WP-26FV-25-R	437.00	363-2045	VT-26F-25-RFX	256.00	820-1380	CK2125VH-F / CK26-25-R FX	314.00
			363-2070	VT-26V-25-RFX	274.00			

* Power cable adapter must be ordered separately

TIG TORCHES & ACCESSORIES

WATER COOLED

- Require cooling water flow of one quart per minute at a maximum of 50 PSI pressure

WP-24W

Small Torch

- Ideal for cramped locations
- Fits through narrow openings yet excellent capacity
- Extremely light and well balanced
- Water cooling requirements: 1 quart per minute at maximum of 50 PSI pressure
- Torch body head: 70° angle
- Torch length: 7 1/2"
- Max capacity: 180 amps
- Handle style: Textured



WP-24W

WP-20

Lightweight, Small Durable

- Compact and well-balanced for general duty use
- Efficient around-the-head cooling for trouble free performance and long life
- Water cooling requirements: 1 quart per minute at maximum of 50 PSI pressure
- Torch body head: 70° angle
- Torch length: 7"
- Max capacity: 250 amps
- Handle style: Textured



WP-20

Description	Amps	Max. Angle	Gas Valve	Power Cable	Accessory Kit **
WP-24W TORCH BODY					
W/insulating gasket	180	70°	No		
WP-24W TORCH PACKAGES - TORCH BODY, HANDLE, 25' POWER CABLE & HOSES					
W/insulating gasket	180	70°	No		-
W/insulating gasket	180	70°	No	1-Piece Rubber Jacketed	-
WP-20 TORCH BODY					
W/cup gasket	250	70°	No		AK-4
W/cup gasket and gas valve	250	70°	Knob & Stem		AK-4
WP-20 TORCH PACKAGES - TORCH BODY, MEDIUM BACK CAP, HANDLE, 25' POWER CABLE & HOSES					
W/cup gasket	250	70°	No	3-Piece Vinyl	AK-4
W/cup gasket and gas valve	250	70°	Knob & Stem	3-Piece Vinyl	AK-4
W/cup gasket	250	70°	No	1-Piece Rubber Jacketed	AK-4
WP-18 TORCH BODY					
W/cup gasket	350	70°	No		AK-3
W/cup gasket and gas valve	350	70°	Knob & Stem		AK-3
WP-18 TORCH PACKAGES - TORCH BODY, LONG BACK CAP, 25' POWER CABLE & HOSES					
W/cup gasket	350	70°	No	3-Piece Vinyl	AK-3
W/cup gasket and gas valve	350	70°	Knob & Stem	3-Piece Vinyl	AK-3
W/cup gasket	350	70°	No	1-Piece Rubber Jacketed	AK-3
W/cup gasket and gas valve	350	70°	Knob & Stem	1-Piece Rubber Jacketed	AK-3
WP-12 TORCH BODY					
W/nozzle gasket	500	70°	No		-
WP-12 TORCH PACKAGES - TORCH BODY, LONG BACK CAP, 25' POWER CABLE & HOSE ASSEMBLY IN RUBBER SHEATH					
W/nozzle gasket	500	70°	No	Rubber	-

** See page 1109 for accessory kits

WP-18

Work Horse for Continuous Duty

- Heavy-duty rugged production torch for continuous duty to 350 amps
- Water cooling requirements: 1 quart per minute at maximum of 50 PSI pressure
- Built-in fingertip gas control valve available on WP-18V models
- Torch body head: 70° angle
- Torch length: 9 1/4"
- Max capacity: 350 amps
- Handle style: Textured



WP-18

WP-12

Totally Sealed Water Chamber with Heavy Duty Components

- Heavy-duty performer with a unique water cooling design
- Heavy-duty collets, collet bodies and gas lens
- Water cooling requirements: 1.5 - 2 quarts per minute at maximum of 50 PSI pressure
- Torch body head: 70° angle
- Torch length: 11 1/2"
- Max capacity: 500 amps
- Handle style: Smooth

WELDCRAFT®



Model No.	Weldcraft Mfg. No.	Price /Each	Model No.	Weldmate Mfg. No.	Price /Each	Model No.	C-K Mfg. No.	Price /Each
366-4726	WP-24W	193.00						
366-4732*	WP-24W-25	347.00						
TTT278*	WP-24W-25-R	532.00						
366-4597	WP-20	125.00				820-1260	CK200	76.10
TTT279	WP-20V	198.00				820-1265	CK200V	114.00
NP477	WP-20-25	252.00				820-1405	CK225	237.00
NP478	WP-20V-25	348.00				820-1420	CK225V	278.00
366-4610*	WP-20-25-R	423.00				818-1471	CK225SF	279.00
366-4543	WP-18	132.00	363-1285	VT-18	84.00	820-1505	CK300	87.40
366-4585	WP-18V	220.00				820-1510	CK300V	138.00
NP479	WP-18-25	279.00				820-1530	CK325	271.00
NP480	WP-18V-25	390.00				820-1545	CK325V	342.00
TTT281*	WP-18-25-R	443.00				TTU659	CK325VSF	405.00
TTT282*	WP-18V-25-R	514.00						
366-4405	WP-12	427.00						
366-4414*	WP-12-25	954.00						

* Power cable adapter must be ordered separately

TIG TORCHES & ACCESSORIES



FLEX-LOC™ TORCHES

- Flex-Loc™ series torch is a variable angle torch that locks into position within a 360° rotation
- Interchangeable heads allow different size tungsten and head sizes to be quickly and efficiently changed
- Ergonomically designed to help eliminate fatigue
- Great for applications requiring a unique angle yet allowing the user a rigid torch

Applications: Cup walking on pipe root welds, welds that require a mirror to access weldment, welds requiring different tungsten sizes.

Torch packages include: Body assembly, replaceable torch head (with heat shield and back cap) and cable assembly

AIR (GAS) COOLED TORCHES

- Gas-cooled models are available with or without gas control valve and have a Hi-Flex one-piece concentric cable assembly
- Length: 7 3/4" without valve; 8 1/2" with valve

WATER COOLED TORCHES

- Water cooled models are equipped with a Tri-Flex cable assembly
- Length: 7 3/4" without valve

821-1750



820-1905

821-1760



820-1920



Model No.	Mfg. No.	Cable Size'	Amps	Cable	Head Style	Price /Each
AIR-COOLED TORCHES WITHOUT VALVE						
820-1905	FL1312	12 1/2	130	1-Piece	FL2L	282.00
TTT376	FL1325	25	130	1-Piece	FL2L	327.00
820-1920	FL1512	12 1/2	150	1-Piece	FL3L	282.00
820-1930	FL1525	25	150	1-Piece	FL3L	327.00
WITH VALVE						
TTT379	FL1312V	12 1/2	130	1-Piece	FL2L	338.00
820-1915	FL1325V	25	130	1-Piece	FL2L	383.00
820-1925	FL1512V	12 1/2	150	1-Piece	FL3L	338.00
820-1935	FL1525V	25	150	1-Piece	FL3L	383.00
WATER-COOLED TORCHES WITHOUT VALVE						
820-1940	FL2312	12 1/2	230	Tri-Flex	FL2L	316.00
820-1945	FL2325	25	230	Tri-Flex	FL2L	349.00
820-2075	FL2512	12 1/2	250	Tri-Flex	FL3L	316.00
820-1950	FL2525	25	250	Tri-Flex	FL3L	349.00

TORCH HEAD SELECTOR CHART

Model No.	Mfg. No.	Amps		Head Style	Price /Each
		Gas-Cooled	Water-Cooled		
821-1750	FL2L	130	230	2 Series	73.30
821-1760	FL3L	150	250	3 Series	73.30

FLEX TORCHES

WELDCRAFT®

WATER-COOLED

- Modular design for easy low-cost repairs
- Tough copper head and coil assembly – runs cooler, lasts longer
- "Bellows" type boot for maximum flexibility
- Built-in restraining wire – resist leaking from coil and boot
- Built-in ball/stem gas control valve for greater control
- Ribbed handle for cool operation
- Heavy-duty, two-piece power cable for uninterrupted use
- Long neck option, **366-4735**, for extended reach requirements
- Maximum amperage is determined by torch assembly and head
- Vinyl for heavy duty use and reinforced neoprene hose for increased durability and flexibility
- Torch assembly includes: **366-1315** and **366-2998** heads, power cable, water hose, gas hose, and handle

TORCH PACKAGE ASSEMBLY

Model No.	Mfg. No.	Power Cable'	Power Cable	Water Hose	Gas Hose	Price /Each
366-7040	WP-225-12	12	45V03	45V07	45V09	364.00
TTT283	WP-225-25	25	45V04	45V08	45V10	399.00
TTT284	WP-225-12-HD	12, Vinyl	45V03HD	45V07HD	45V09	439.00
TTT285	WP-225-25-HD	25, Vinyl	45V04HD	45V08HD	45V10	538.00
TTT286	WP-225-12-R	12, Neoprene	45V03R	45V07R	45V09R	470.00
366-7200	WP-225-25-R	25, Neoprene	45V04R	45V08R	45V10R	549.00

TORCH PACKAGE ASSEMBLY

Model No.	Mfg. No.	Power Cable'	Power Cable	Water Hose	Gas Hose	Price /Each
TTT287	WP-25-12	12	45V03	45V07	45V09	358.00
366-4741	WP-25-25	25	45V04	45V08	45V10	376.00
TTT290	WP-25-12-R	12, Neoprene	45V03R	45V07R	45V09R	479.00

FLEXIBLE TORCH BODY

Model No.	Mfg. No.	Max. Amps	Price /Each
FOR USE WITH INTERCHANGEABLE HEADS			
366-7000	WP-225	225	248.00

LONG REACH FLEX-PENCIL TYPE TORCH BODY

Model No.	Mfg. No.	Max. Amps	Price /Each
366-4735	WP-25	200	263.00

INTERCHANGEABLE HEADS



Model No.	Mfg. No.	Max. Amps A/C*	Max. Amps W/C**	Head Angle°	Fits	Price /Each
366-1315	9-70	125	200	70	WP-9, WP-9V WP-20 WP-225	55.90
TTT292	9P	125	200	180	WP-9, WP-9V WP-20 WP-225	60.30
TTT293	24	80	160	70	WP-24, WP-24W WP-225	60.30
366-2998	1726	150/200	225	70	WP-17, WP-17V WP-18, WP-18V, WP-26, WP-26V WP-225	55.90
TTT294	1726P	150/200	225	180	WP-17, WP-17V WP-18, WP-18V, WP-26, WP-26V WP-225	60.30
TTT295	24-90	80	160	90	WP-24, WP-24W WP-225	60.30

* Air cooled

** Water cooled

CRAFTER SERIES WATER-COOLED TORCHES

- Engineered for the professional TIG welder
- Patented integral double lip back cap seal, series **CS310**, improves high frequency shielding and reduces gas leakage
- Self-indexing flat top handle lets you orient the torch by feel, improving comfort and torch control
- Reinforced rubber hose sets remain flexible in cold weather
- ColorSmart™ colour-coded hose set quickly identifies cold water, hot water return, power and gas
- Mechanical hose connections on the water and gas hoses eliminate the need for wire ties

Torch Packages come assembled with:

CS310

- Torch body
- Handle
- Gas and water hoses
- Power cable
- #6 HPN nozzle
- 3/32" collet
- 3/32" collet body
- 3/32" x 7" tungsten electrode
- Long back cap
- Cable cover

CS410

- Torch body
- Handle
- Gas and water hoses
- Power cable
- #8 HPN nozzle
- 1/8" collet
- 1/8" collet body
- 1/8" x 7" tungsten electrode
- Long back cap
- Cable cover

WELDCRAFT®

Model No.	Mfg. No.	Amps	Description	Price /Each
CS310				
TTT296	CS310-12	310	Torch w/12' cable	455.00
366-3730	CS310-25	310	Torch w/25' cable	688.00
CS410				
TTT297	CS410-12	410	Torch w/12' cable	556.00
366-3745	CS410-25	410	Torch w/25' cable	814.00



LAVA NOZZLES (CERAMIC)

- Made from grade "A" lava materials
- Less shock-and heat-resistant than alumina nozzles
- Functions in confined areas where excessive heat is reflected back into the nozzle
- Ideal for general applications
- Packed 10 nozzles per box

WELDCRAFT®

WELD-MATE



Size	Orifice"	Fits Torch Series	Model No.	Weldcraft Mfg. No.	Price /Each	Model No.	Weldmate Mfg. No.	Price /Each	Model No.	C-K Mfg. No.	Price /Each
LAVA NOZZLES - 1 27/32" LENGTH											
4	1/4	WP-17, WP-17V,	NP431	105Z43	20.80				818-2185	3C4	13.30
5	5/16	WP-18, WP-18V,	366-2800	105Z42	20.80				818-2210	3C5	13.30
6	3/8	WP-26, WP-26V	366-2806	105Z44	20.80	363-1355	105Z44	13.30	818-2230	3C6	13.30
7	7/16		366-2809	105Z45	20.80	363-1360	105Z45	13.30	818-2240	3C7	13.30
8	1/2		366-1000	08N78	23.50	363-1330	08N78	13.30	818-2250	3C8	13.30
10	5/8		NP430	08N79	23.50	363-1335	08N79	13.30	818-2150	3C10	13.30
12	3/4		TTT308	08N80	23.50	363-1340	08N80	13.30	TTT001	3C12	13.30
LAVA NOZZLES - 1 5/32" LENGTH											
4	1/4	WP-9, WP-9V,	366-1609	13N14	16.60				818-1730	2C4	11.50
5	5/16	WP-20,	366-1612	13N15	16.60				818-1755	2C5	11.50
6	3/8	WP-25,	366-1615	13N16	16.60				818-1765	2C6	11.50
7	7/16		NP440	13N17	16.60				818-1775	2C7	11.50
8	1/2		NP441	13N18	16.60				818-1780	2C8	11.50
10	5/8		366-1624	13N19	16.60				818-1695	2C10	11.50
LAVA NOZZLES - 5/8" LENGTH											
0.165	0.165	WP-24, WP-24V	TTT309	53N23	17.40						
4	1/4		366-2368	53N24	17.40				818-2785	8C4	11.50
5	5/16		366-2371	53N25	17.40				818-2800	8C5	11.50
6	3/8		366-2377	53N27	17.40				818-2805	8C6	11.50
LAVA NOZZLES - 1 1/8" LENGTH											
4L	1/4	WP-24, WP-24V	366-2380	53N28	18.50				818-2795	8C4L	13.70
6L	3/8		366-2374	53N26	18.50						
LONG LAVA NOZZLES - 3 7/32" LENGTH											
4L	1/4	WP-17, WP-17V,	NP456	12N03	34.60				818-2205	3C4L	22.70
5L	5/16	WP-18, WP-18V,	NP457	105Z60	34.60				818-2225	3C5L	22.70
6L	3/8	WP-26, WP-26V	366-1576	12N02	34.60				818-2235	3C6L	22.70
7L	7/16		NP459	105Z61	34.60				818-2245	3C7L	22.70
LONG LAVA NOZZLES - 1 7/8" LENGTH											
3L	3/16	WP-9, WP-9V,	366-2941	796F70	24.20				818-1725	2C3L	21.60
4L	1/4	WP-20,	366-2926	796F71	24.20				818-1750	2C4L	21.60
5L	5/16	WP-25	366-2929	796F72	24.20				818-1760	2C5L	21.60
6L	3/8		366-2932	796F73	24.20				818-1770	2C6L	21.40
LONG LAVA NOZZLES - 2 1/2" LENGTH											
3XL	3/16	WP-9, WP-9V,	TTT310	796F74	28.20						
4XL	1/4	WP-20, WP-25	366-2938	796F75	28.20						

Note: The nozzle indicates the orifice (I.D. of the outlet end) in 1/16ths of an inch. No. 4 = 1/4" I.D.



NP431



363-1330



818-1730



NP457

TIG TORCHES & ACCESSORIES

ALUMINA NOZZLES

- Made from high strength alumina materials
- Very good electrical insulating properties
- Exceptionally high impact resistance, heat resistance and thermal conductivity
- Recommended for most welding operations
- Resists splatter build-up
- Packed 10 nozzles per box

WELDCRAFT



Size	Orifice"	Fits Torch Series	Model No.	Weldcraft Mfg. No.	Price /Each	Model No.	Weldmate Mfg. No.	Price /Each	Model No.	C-K Mfg. No.	Price /Each
ALUMINA NOZZLES – 1 27/32" LENGTH											
4	1/4	WP-17, WP-17V,	366-1504	10N50	3.02	363-1000	10N50	0.99	818-2050	3A4	1.94
5	5/16	WP-18, WP-18V,	NP396	10N49	3.02	363-1005	10N49	0.99	818-2060	3A5	1.94
6	3/8	WP-26, WP-26V	366-1492	10N48	3.02	363-1010	10N48	0.99	818-2070	3A6	1.94
7	7/16		366-1486	10N47	3.02	363-1015	10N47	0.99	818-2080	3A7	1.94
8	1/2		366-1483	10N46	3.02	363-1020	10N46	0.99	818-2090	3A8	1.94
10	5/8		366-1480	10N45	3.02	363-1025	10N45	0.99	818-2040	3A10	1.94
12	3/4		366-1477	10N44	3.02	363-1030	10N44	0.99	818-2045	3A12	1.94
ALUMINA NOZZLES – 1 5/32" LENGTH											
4	1/4	WP-9, WP-9V,	366-1591	13N08	2.76	363-1035	13N08	0.85	818-1615	2A4	1.94
5	5/16	WP-20,	366-1594	13N09	2.76	363-1040	13N09	0.85	818-1625	2A5	1.94
6	3/8	WP-25	366-1597	13N10	2.76	363-1045	13N10	0.85	818-1635	2A6	1.94
7	7/16		366-1600	13N11	2.76	363-1050	13N11	0.85	818-1645	2A7	1.94
8	1/2		366-1603	13N12	2.76	363-1055	13N12	0.85	818-1655	2A8	1.94
10	5/8		366-1606	13N13	2.76	363-1060	13N13	0.85	818-1610	2A10	1.94
ALUMINA NOZZLES – 1 1/4" LENGTH											
4	1/4	WP-12	TTT298	14N57	7.95						
5	5/16		TTT299	14N58	7.95						
6	3/8		366-1678	14N59	7.95						
7	7/16		366-1681	14N60	7.95						
8	1/2		366-1684	14N61	7.95						
10	5/8		366-1687	14N61-10	23.10						
12	3/4		366-1690	14N61-12	23.10						
ALUMINA NOZZLES – 5/8" LENGTH											
4	1/4	WP-24, WP-24W	TTT300	A53N24	9.34						
5	5/16		TTT301	A53N25	9.34						
LONG ALUMINA NOZZLES – 3" LENGTH											
5L	5/16	WP-17, WP-17V,	NP445	10N49L	28.10				818-3625	3A5L	21.30
6L	3/8	WP-18, WP-18V,	NP446	10N48L	21.30				TTT004	3A6L	21.30
7L	7/16	WP-26, WP-26V	366-1489	10N47L	28.10				TTT005	3A7L	21.30
ALUMINA GAS LENS NOZZLES – 1 5/8" LENGTH (ALSO ORDER INSULATOR)											
4	1/4	WP-17, WP-17V,	366-2467	54N18	3.03	363-1815	54N18	1.15	818-2115	3AG4	1.94
5	5/16	WP-18, WP-18V,	366-2461	54N17	3.03	363-1810	54N17	1.15	818-2120	3AG5	1.94
6	3/8	WP-26, WP-26V	NP386	54N16	3.03	363-1805	54N16	1.15	818-2125	3AG6	1.94
7	7/16		366-2449	54N15	3.03	363-1800	54N15	1.15	818-2130	3AG7	1.94
8	1/2		366-2446	54N14	3.03	363-1795	54N14	1.15	818-2135	3AG8	1.94
ALUMINA GAS LENS NOZZLES – 1 1/8" LENGTH (ALSO ORDER INSULATOR)											
Short	11/16	WP-17, WP-17V WP-18, WP-18V WP-26, WP-26V	TTT307	54N19	2.97	363-2080	54N19	1.15	818-2105	3AG11	1.94
ALUMINA GAS LENS NOZZLES – 1" LENGTH (ALSO ORDER INSULATOR)											
4	1/4	WP-9, WP-9V,	366-2392	53N58	2.82				818-1665	2AG4	1.94
5	5/16	WP-20,	NP390	53N59	2.82	363-1735	53N59	0.99	818-1670	2AG5	1.94
6	3/8	WP-24,	NP391	53N60	2.82	363-1740	53N60	0.99	818-1675	2AG6	1.94
7	7/16	WP-25,	366-2404	53N61	2.82	363-1745	53N61	0.99	818-1680	2AG7	1.94
ALUMINA GAS LENS NOZZLES – 1 7/8" LENGTH, LARGE DIAMETER GAS LENS (ALSO ORDER INSULATOR)											
10	5/8	WP-26, WP-26V,	366-2434	53N88	6.67	363-1780	53N88	2.56	818-2100	3AG10LD	4.27
12	3/4	WP-12	366-2431	53N87	6.67	363-1775	53N87	2.56	818-2110	3AG12LD	4.27
Short	15/16		366-2437	53N89	6.67	363-1785	53N89	4.27			



NP396



363-1035



GET CLEAN

Industrial handsoap with scrubbing particles for stubborn grease and grime
TRY SOME TODAY!

Model JG223
See page 327



ACCESSORIES AND SPARE PARTS

- Accessories, such as collets, collet bodies, different length back caps, gas lens collet bodies and nozzles, must be ordered to complete the torch package
- Accessories may be ordered in convenient accessory kits or separately as needed



TTT311



366-2473



366-1882



TTT322



TTT325



366-1627



TTT312



366-3484

WELDCRAFT



Size*	Fits Torch Series	Model No.	Weldcraft Mfg. No.	Price /Each	Model No.	Weldmate Mfg. No.	Price /Each	Model No.	C-K Mfg. No.	Price /Each
COLLETS										
0.020	WP-9, WP-9V,	366-1627	13N20	2.25				818-1710	2C20	1.51
0.040	WP-20,	366-1633	13N21	2.25	363-1095	13N21	0.95	818-1735	2C40	1.51
1/16	WP-25	366-1639	13N22	2.25	363-1100	13N22	1.51	818-1700	2C116	1.51
3/32		NP413	13N23	2.25	363-1105	13N23	0.95	818-1715	2C332	1.51
1/8		NP412	13N24	2.25	363-1110	13N24	0.95	818-1740	2C418	1.51
0.020	WP-17, WP-17V,	TTT311	10N21	4.10				818-2170	3C20	1.81
0.040	WP-18, WP-18V,	366-1435	10N22	4.10	363-1070	10N22	1.15	818-2190	3C40	1.81
1/16	WP-26, WP-26V	366-1441	10N23	4.10	363-1075	10N23	1.15	818-2155	3C116	1.81
3/32		366-1447	10N24	4.10	363-1080	10N24	1.15	818-2175	3C332	1.81
1/8		366-1453	10N25	4.10	363-1085	10N25	1.15	818-2195	3C418	1.81
5/32		366-2473	54N20	4.43	363-1820	54N20	1.15	818-2215	3C532	1.81
0.020	WP-24, WP-24W	TTT312	53N15	3.79	363-1705	53N15	1.81	TTT006	8C20	2.02
0.040		TTT313	53N16	3.79	363-1710	53N16	1.81	818-8C40	8C40	2.02
1/16		366-2338	53N14	3.79	363-1700	53N14	2.02	818-2770	8C116	2.02
3/32		366-1882	24C332	3.79				818-2780	8C332	2.02
0.020	For Gas Lens	TTT314	53N62	4.43	363-1755	53N62	2.05	TTT007	8CG20	2.73
0.040		TTT315	53N63	4.43	363-1760	53N63	2.05	818-2845	8CG40	2.73
1/16		TTT316	53N64	4.43				818-2835	8CG116	2.73
3/32		366-1891	24GLC332	4.25				818-2840	8CG332	2.73
1/16	WP-12	TTT317	85Z14	37.00						
3/32		TTT318	85Z15	37.00						
1/8		TTT319	85Z16	37.00						
5/32		366-2740	85Z17	37.00						
3/16		TTT320	85Z18	37.00						
1/4		TTT321	85Z19	37.00						
COLLET BODIES										
0.020	WP-9, WP-9V,	TTT322	13N25	4.40				818-1790	2CB20	3.09
0.040	WP-20,	366-1660	13N26	4.40	363-1145	13N26	2.04	818-1800	2CB40	3.09
1/16	WP-25	366-1663	13N27	4.40	363-1150	13N27	2.04	818-1785	2CB116	3.09
3/32		NP406	13N28	4.40	363-1155	13N28	2.04	818-1795	2CB332	3.09
1/8		366-1669	13N29	4.40	363-1160	13N29	2.04	818-1805	2CB418	3.09
0.020	WP-17, WP-17V,	366-1465	10N29	5.89	363-1115	10N29	4.01			
0.040	WP-18, WP-18V,	NP400	10N30	5.89	363-1120	10N30	3.35	818-2270	3CB40	4.01
1/16	WP-26, WP-26V	366-1471	10N31	5.89	363-1125	10N31	3.35	818-2255	3CB116	4.01
3/32		366-1474	10N32	5.89	363-1130	10N32	3.35	818-2265	3CB332	4.01
1/8		366-1462	10N28	5.89	363-1135	10N28	3.35	818-2275	3CB1418	4.01
5/32		366-3484	406488	5.89	363-1465	406488	4.01	818-2280	3CB532	4.01
0.020	WP-24, WP-24W*	TTT323	53N17	8.10	363-1715	53N17	3.25	818-3645	8CB20	3.25
0.040		TTT324	53N18	8.10	363-1720	53N18	3.25	818-3650	8CB40	3.25
1/16		366-2353	53N19	8.62	363-1725	53N19	3.25	818-2815	8CB116	3.25
3/32		TTT325	24CB332	9.13				818-2825	8CB332	3.25
1/16 - 1/4	WP-12	366-1564	11WP65	46.70						

* Order Wrench for WP-24, 24W Collet Body

TIG TORCHES & ACCESSORIES

GAS LENS COLLET BODIES

- Eliminates turbulence in the gas shielding stream as it emerges from the nozzle, better shielding patterns
- Long stable stream allows the electrode to be extended farther beyond the end of the nozzle for improved visibility of the weld zone

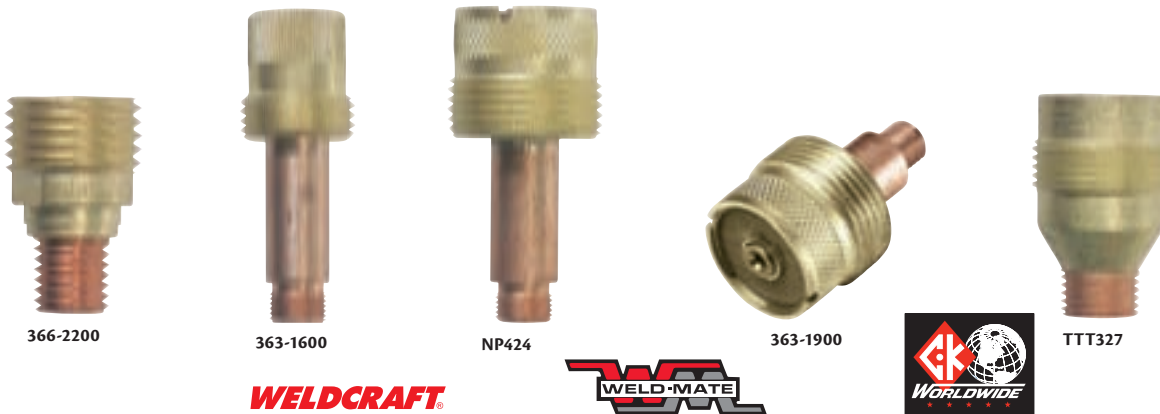

Size"	Fits Torch Series	Model No.	Weldcraft Mfg. No.	Price /Each	Model No.	Weldmate Mfg. No.	Price /Each	Model No.	C-K Mfg. No.	Price /Each
GAS LENS COLLET BODIES (ALSO ORDER INSULATOR)										
0.020	WP-9, WP-9V,	366-2200	45V41	11.90	363-1630	45V41	8.15	TTT008	2GL20	8.15
0.040	WP-20,	366-2203	45V42	11.90	363-1635	45V42	5.45	818-1830	2GL40	8.15
1/16	WP-25	366-2206	45V43	11.90	363-1440	45V43	5.45	818-1820	2GL116	8.15
3/32		NP423	45V44	11.90	363-1645	45V44	5.45	818-1825	2GL332	8.15
1/8		366-2212	45V45	11.90	363-1650	45V45	5.45	818-1835	2GL418	8.15
0.020	WP-17, WP-17V,	TTT326	45V29	13.90				818-2360	3GL20	9.07
0.040	WP-18, WP-18V,				363-1600	45V24	6.51	818-2375	3GL40	9.07
1/16	WP-26, WP-26V	366-2185	45V25	13.90	363-1605	45V25	6.51	818-2345	3GL116	9.07
3/32		NP419	45V26	13.90	363-1610	45V26	6.51	818-2365	3GL332	9.07
1/8		366-2191	45V27	13.90	363-1615	45V27	6.51	818-2380	3GL418	9.07
5/32		366-2194	45V28	13.90	363-1620	45V28	6.51	818-2390	3GL532	9.07
0.020 - 0.040	WP-17, WP-17V,	NP424	45V0204	27.50						
1/16	WP-18, WP-18V,	NP418	45V116	27.50	363-1595	45V116	10.10			
3/32	WP-26, WP-26V	366-2227	45V64	27.50	363-1665	45V64	10.10	818-2370	3GL332LD	19.90
1/8	Large Dia. Gas Lens	366-3490	995795	27.50	363-1900	995795	19.90	818-2385	3GL418LD	19.90
5/32		366-2221	45V63	27.50	363-1660	45V63	10.10	818-2395	3G6532LD	19.90
1/16	WP-12	TTT327	11GL16	131.00						
3/32		TTT328	11GL32	131.00						
1/8		TTT329	11GL18	131.00						
5/32		TTT330	11GL53	131.00						
3/16		366-1534	11GL36	131.00						
INSULATORS										
	WP-17, WP-17V, WP-18, WP-18V, WP-26, WP-26V Gas Lens	366-2440	54N01	6.19	363-1790	54N01	1.71			
	Large Diameter Gas Lens (use on above torches)	366-2497	54N63	13.10	363-1840	54N63	8.15			
	WP-9, WP-9V, WP-20, WP-25 (supplied on torch body)	366-3487	598882	3.82	363-1885	598882	2.73			
	WP-24, WP-24V Gas Lens	366-2419	53N66	8.68	363-1770	53N66	2.04			
	WP-12 Gas Lens Stubby Collet Body	TTT331 366-1756	12GLG 18CG20	28.80 15.50						
BACK CAPS										
Short	WP-9, WP-9V,	366-2116	41V33	8.53	363-1310	41V33	1.38	818-1390	200S	4.73
Medium	WP-20	366-2119	41V35	9.77	363-1315	41V35	1.64	818-1380	200M	4.53
Long		366-2083	41V24	10.10	363-1305	41V24	1.87	818-1375	200L	4.73
Long	WP-17, WP-17V,	366-2611	57Y02	6.92				818-1925	300L	3.81
Short	WP-18, WP-18V, WP-26, WP-26V	366-2626	57Y04	9.13				818-1940	300S	2.89
Long	WP-12	366-2548	56Y44	40.40						
Short		366-2551	56Y45	27.10						



366-2119



366-2611



366-2626

STUBBY COLLETS/COLLET BODIES

- Stubby collet system allows use of a smaller nozzle
- Reduces overall torch head length giving access to confined areas
- Eliminates the need and cost of changing to a smaller torch



WELDCRAFT

Size"	Fits Torch Series	Model No.	Weldcraft Mfg. No.	Price /Each	Model No.	C-K Mfg. No.	Price /Each
0.040	WP-17, WP-17V,	366-1438	10N22S	6.67	818-2505	4C40	3.61
1/16	WP-18, WP-18V,	366-1444	10N23S	6.67	818-2480	4C116	3.61
3/32		NP472	10N24S	6.67	818-2495	4C332	3.61
1/8		366-1459	10N25S	6.67	818-2510	4C418	3.61

POWER CABLE ADAPTERS

- Adapters are not supplied with the torch packages
- Order adapter separately if needed



WELDCRAFT

Fits Torch Series	Model No.	Weldcraft Mfg. No.	Price /Each	Model No.	Weldmate Mfg. No.	Price /Each	Model No.	C-K Mfg. No.	Price /Each
WP-18, WP-18V, WP-20, WP-24W WP-25 WP-12	366-2179	45V11	27.90	363-1590	45V11	16.20	818-1850	2PCA	22.50
WP-9, WP-9V*, WP-17*, WP-17V*,	366-2827	10S257	19.20	363-1365	10S257	14.70	818-1185	15PCA	14.70
WP-24	366-2383	53N43	30.50				818-1315	1PCA	19.60
WP-26*, WP-26V*	366-2218	45V62	29.80	363-1655	45V62	16.20			

*Torch packages are supplied with two-piece power cable assembly. Adapters are required with optional one-piece power cable assembly only.

ACCESSORY KITS

WP-9 TORCH SERIES

- 1 Long back cap
 - 2 Collets: 0.040", 1/16"
 - 2 Collet bodies: 0.040", 1/16"
 - 3 Alumina nozzles: 4, 5, 6
 - 2 Tungsten electrodes 2%: 0.040", 1/16" x 7"
- Model No. 366-3613 Mfg. No. AK-1**
Price/Each \$37.70

WP-17, WP-17V TORCH SERIES

- 1 Short back cap
 - 3 Collets: 0.040", 1/16", 3/32"
 - 3 Collet bodies: 0.040", 1/16", 3/32"
 - 3 Alumina nozzles: 4, 5, 6
 - 3 Tungsten electrodes 2%: 0.040", 1/16", 3/32" x 7"
- Model No. NT529 Mfg. No. AK-2**
Price/Each \$51.10

WP-18, WP-18V, WP-26, WP-26V TORCH SERIES

- 1 Short back cap
 - 3 Collets: 1/16", 3/32", 1/8"
 - 3 Collet bodies: 1/16", 3/32", 1/8"
 - 3 Alumina nozzles: 5, 6, 8
 - 3 Tungsten electrodes 2%: 1/16", 3/32", 1/8" x 7"
- Model No. NT530 Mfg. No. AK-3**
Price/Each \$59.50



WP-20 TORCH SERIES

- 1 Long back cap
 - 3 Collets: 1/16", 3/32", 1/8"
 - 3 Collet bodies: 1/16", 3/32", 1/8"
 - 3 Alumina nozzles: 5, 6, 7
 - 3 Tungsten electrodes 2%: 1/16", 3/32", 1/8" x 7"
- Model No. NT531 Mfg. No. AK-4**
Price/Each \$57.80

WP-24 TORCH SERIES

- 2 Collets: 0.040", 1/16"
 - 2 Collet bodies: 0.040", 1/16"
 - 3 Alumina nozzles: 4, 5, 6
 - 1 Collet body wrench
 - 2 Tungsten electrodes 2%: 0.040", 1/16" x 7"
- Model No. 366-3631 Mfg. No. AK-5**
Price/Each \$51.90

TIG TORCHES & ACCESSORIES

POWER CABLES – WATER AND GAS HOSES



WELDCRAFT



Description	Size*	Fits Torch Series	Model No.	Weldcraft Mfg. No.	Price /Each	Model No.	Weldmate Mfg. No.	Price /Each	Model No.	C-K Mfg. No.	Price /Each
POWER CABLES - WATER & GAS HOSES (VINYL TUBE CONSTRUCTION)											
Power Cable	12 1/2	WP-9, WP-9V,	366-2599*	57Y01	84.10						
Power Cable	25	WP-17, WP-17V	366-2614*	57Y03	126.00						
Power Cable	12 1/2	WP-18, WP-18V	366-1993	40V64	81.20				818-1965	312PC	59.80
Power Cable	25		366-2086	41V29	106.00	363-1500	41V29	80.70	818-1995	325PC	84.00
Water Hose	12 1/2		366-2002	40V74	26.30	363-1480	40V74	16.80	818-1975	312WH	17.50
Water Hose	25		366-2104	41V32	34.30	363-1520	41V32	18.10	818-2005	325WH	18.80
Gas Hose	12 1/2		TTT412	40V75	26.10	363-1490	40V75	16.80	818-1950	312AH	17.50
Gas Hose	25		366-2095	41V30	34.30	363-1510	41V30	22.70	818-1980	325AH	22.70
Power Cable	12 1/2	WP-20, WP-20V	366-2131	45V03	71.20	363-1530	45V03	54.30	818-1430	212PC	56.50
Power Cable	25	WP-25	366-2137	45V04	83.40	363-1540	45V04	63.70	818-1465	225PC	70.90
Water Hose	12 1/2		366-2155	45V07	25.60				818-1440	212WH	17.40
Water Hose	25		366-2161	45V08	33.40				818-1475	225WH	20.80
Gas Hose	12 1/2		366-2167	45V09	25.60				818-1415	212AH	14.40
Gas Hose	25		366-2173	45V10	26.60				818-1455	225AH	20.80
Heavy-Duty Power Cable	12 1/2		TTT333	45V03HD	120.00						
Heavy-Duty Power Cable	25		TTT334	45V04HD	149.00						
Heavy-Duty Water Hose	12 1/2		TTT335	45V07HD	39.90						
Heavy-Duty Water Hose	25		TTT336	45V08HD	62.80						
RUBBER POWER CABLES (RUBBER HOSE CONSTRUCTION)											
Power Cable	12 1/2	WP-24	TTT337	56Y38R	127.00						
Power Cable	25	WP-9, WP-9V,	TTT338	56Y97R	216.00						
Power Cable	12 1/2	WP-17, WP-17V	TTT339	57Y01R	96.50	363-1865	57Y01R	66.00	818-1150	1512PCHF	96.80
Power Cable	25		366-2623	57Y03R	137.00	363-1880	57Y03R	99.10	818-1170	1525PCHF	122.00
Power Cable	12 1/2	WP-18, WP-18V	TTT340	40V64R	100.00	363-1475	40V64R	74.60			
Power Cable	25		366-2092	41V29R	127.00	363-1505	41V29R	99.90			
Power Cable	12 1/2	WP-26, WP-26V	366-2254	46V28R	127.00	363-1670	26V28R	95.90			
Power Cable	25		366-2263	46V30R	189.00	363-1690	46V30R	168.00			
2-PIECE POWER CABLES - GAS HOSES											
Power Cable & Gas Hose	12 1/2	WP-9, WP-9V,	TTT341	57Y01-2	119.00				TTT187	1512PCN	68.70
Gas Hose only	12 1/2	WP-17, WP-17V	366-2170	45V09R	51.60	363-1575	45V09R	38.30			
Power Cable & Gas Hose	25		366-2617	57Y03-2	241.00				818-1180	1525PCN	103.00
Gas Hose only	25		366-2176	45V10R	79.30	363-1585	45V10R	64.20			
Power Cable & Gas Hose	12 1/2	WP-26, WP-26V	366-2251	46V28-2	135.00	363-1675	46V28-2	95.90			
Gas Hose only	12 1/2					363-1495	40V75R	38.30			
Power Cable & Gas Hose	25		366-2260	46V30-2	290.00	363-1685	46V30-2	140.00			
Gas Hose only	25					363-1515	41V30R	64.20			

*Rubber power cables are recommended for superior service

FUSE BLOCK ASSEMBLY

- Water-cooled power cables can burn up within seconds if water is not circulating through the cable assembly
- If water is not present over the fuse link, it will burn up at around 6 amps



Model No.	Mfg. No.	Description	Price /Each
818-2675	550FA	550 Amps Fuse Block	105.00
818-2670	550F	550 Amps Fuse, 5/Pkg.	23.10

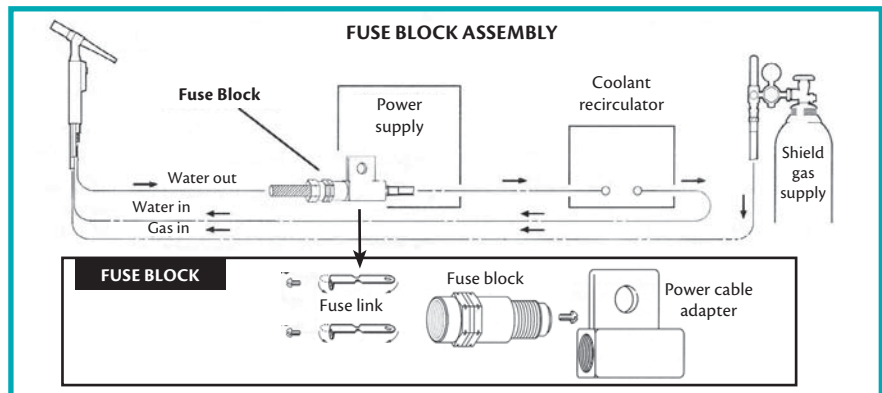

PYTHONRAP™ CABLE COVERS

- Nylon cover
- Full length zipper
- 22' L x 4" W

Model No. NT887
Price/Each \$42.00



CABLE PROTECTORS

- Durable leather with Kevlar® sewn seams
- Lightweight to enhance flexibility and strength
- Metal snaps every 3"
- For TIG, MIG, plasma and flux-cored torch cable/hose assembly
- 22' L x 4" W

Model No. NP520
Price/Each \$62.95



AMPERAGE CONTROLS

- Remote amperage controls provide welding machine contactor on-off, activate gas and/or water solenoids, and provide full range current output control
- Fingertip controls are available in either a rotary or linear slide potentiometer configuration
- Handle styles include, velcro straps where one size fits all handle diameters and retrofits very easily on all makes of torches or built into the handle as original equipment
- Adapts to most standard TIG power supplies
- Protected against high frequency

ROTARY MODEL

- "Plug and Play" replacement potentiometer assembly, no soldering required

LINEAR MODEL

- Amptrak™ remote current control can be ordered either built into a CK torch handle as original equipment or in the velcro model where one size fits all
- Linear slide actuator for complete on/off and full amperage control

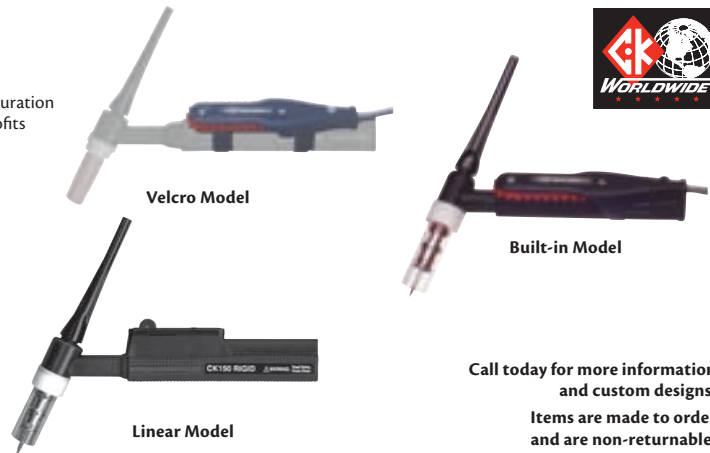

Call today for more information and custom designs.
Items are made to order and are non-returnable.

AMPERAGE REMOTE CONTROL SELECTOR CHART

MACHINE MAKE Potentiometer Rating	AMP CONTROL TYPE	PLUG CONFIG & PIN COUNT	CONTROL CABLE LENGTH	VELCRO STRAPS One Size Fits All	BUILT IN HANDLE FOR CK TORCHES		
					Small	Medium	Large
					CK9, CK17, CK20, CK24, CK24W, CK80, CK90, CK100, CK130, CK150, CKC150*, CK200, CKT200, FLEX-LOC*	CK230, CKA10, CKA20, TL18, TL26, TL210, TL300	CK18, CK26, CK210, CK300, CK350, CK510
HOBART 25 K Ohm	Rotary	10 Pin Plug	15 ft. (4.6 m) 28 ft. (8.5 m) 53 ft. (16.2 m)	--- RACCV-25-2-H10 RACCV-25-3-H10	RAC25-25-1-H10 RAC25-25-2-H10 RAC25-25-3-H10	RAC2M-25-1-H10 RAC2M-25-2-H10 RAC2M-25-3-H10	
	Linear	10 Pin Plug	15 ft. (4.6 m) 28 ft. (8.5 m) 53 ft. (16.2 m)	AMT CV-25-1-H10 AMT CV-25-2-H10 AMT CV-25-3-H10	AMT 2 S-25-1-H10 AMT 2 S-25-2-H10 AMT 2 S-25-3-H10	AMT 2 M-25-1-H10 AMT 2 M-25-2-H10 AMT 2 M-25-3-H10	AMT 2 L-25-1-H10 AMT 2 L-25-2-H10 AMT 2 L-25-3-H10
LINCOLN® ELECTRIC 10 K Ohm	Rotary	14 Pin Plug	14 Pin Plug 28 ft. (8.5 m) 53 ft. (16.2 m)	15 ft. (4.6 m) RACCV-10-2-L14 RACCV-10-3-L14	RACCV-10-1-L14	RAC25-10-1-L14	RAC2M-10-1-L14
					RAC25-10-2-L14	RAC2M-10-2-L14	
					RAC25-10-3-L14	RAC2M-10-3-L14	
		5 Pin Plug	15 ft. (4.6 m) 28 ft. (8.5 m) 53 ft. (16.2 m)	RACCV-10-1-L5 RACCV-10-2-L5 RACCV-10-3-L5	RAC25-10-1-L5	RAC2M-10-1-L5	
					RAC25-10-2-L5	RAC2M-10-2-L5	
					RAC25-10-3-L5	RAC2M-10-3-L5	
	6 Pin Plug	15 ft. (4.6 m) 28 ft. (8.5 m) 53 ft. (16.2 m)	RACCV-10-1-L6 RACCV-10-2-L6 RACCV-10-3-L6	RAC25-10-1-L6	RAC2M-10-1-L6		
				RAC25-10-2-L6	RAC2M-10-2-L6		
				RAC25-10-3-L6	RAC2M-10-3-L6		
	Linear	14 Pin Plug	15 ft. (4.6 m) 28 ft. (8.5 m) 53 ft. (16.2 m)	AMT CV-10-1-L14 AMT CV-10-2-L14 AMT CV-10-3-L14	AMT 2 S-10-1-L14	AMT 2 M-10-1-L14	AMT 2 L-10-1-L14
					AMT 2 S-10-2-L14	AMT 2 M-10-2-L14	AMT 2 L-10-2-L14
					AMT 2 S-10-3-L14	AMT 2 M-10-3-L14	AMT 2 L-10-3-L14
5 Pin Plug		15 ft. (4.6 m) 28 ft. (8.5 m) 53 ft. (16.2 m)	AMT CV-10-1-L5 AMT CV-10-2-L5 AMT CV-10-3-L5	AMT 2 S-10-1-L5	AMT 2 M-10-1-L5	AMT 2 L-10-1-L5	
				AMT 2 S-10-2-L5	AMT 2 M-10-2-L5	AMT 2 L-10-2-L5	
				AMT 2 S-10-3-L5	AMT 2 M-10-3-L5	AMT 2 L-10-3-L5	
6 Pin Plug	15 ft. (4.6 m) 28 ft. (8.5 m) 53 ft. (16.2 m)	AMT CV-10-1-L6 AMT CV-10-2-L6 AMT CV-10-3-L6	AMT 2 S-10-1-L6	AMT 2 M-10-1-L6	AMT 2 L-10-1-L6		
			AMT 2 S-10-2-L6	AMT 2 M-10-2-L6	AMT 2 L-10-2-L6		
			AMT 2 S-10-3-L6	AMT 2 M-10-3-L6	AMT 2 L-10-3-L6		
LINDE 25 K Ohm	Rotary	3 & 3 Pin Pig -Tails Hubbell	15 ft. (4.6 m) 28 ft. (8.5 m) 53 ft. (16.2 m)	RACCV-25-1-LIND RACCV-25-2-LIND RACCV-25-3-LIND	RAC25-25-1-LIND RAC25-25-2-LIND RAC25-25-3-LIND	RAC2M-25-1-LIND RAC2M-25-2-LIND RAC2M-25-3-LIND	
	Linear	3 & 3 Pin Pig -Tails Hubbell	15 ft. (4.6 m) 28 ft. (8.5 m) 53 ft. (16.2 m)	AMT CV-25-1-LIND AMT CV-25-2-LIND AMT CV-25-3-LIND	AMT 2 S-25-1-LIND AMT 2 S-25-2-LIND AMT 2 S-25-3-LIND	AMT 2 M-25-1-LIND AMT 2 M-25-2-LIND AMT 2 M-25-3-LIND	AMT 2 L-25-1-LIND AMT 2 L-25-2-LIND AMT 2 L-25-3-LIND
MILLER ELECTRIC® 1 K Ohm	Rotary	14 Pin Plug	15 ft. (4.6 m) 28 ft. (8.5 m) 53 ft. (16.2 m)	RACCV-1-1-M14 RACCV-1-2-M14 RACCV-1-3-M14	RAC25-1-1-M14	RAC2M-1-1-M14	
					RAC25-1-2-M14	RAC2M-1-2-M14	
		5 Pin Plug	15 ft. (4.6 m) 28 ft. (8.5 m) 53 ft. (16.2 m)	RACCV-1-1-M5 RACCV-1-2-M5 RACCV-1-3-M5	RAC25-1-1-M5	RAC2M-1-1-M5	
					RAC25-1-2-M5	RAC2M-1-2-M5	
	Linear	14 Pin Plug	15 ft. (4.6 m) 28 ft. (8.5 m) 53 ft. (16.2 m)	AMT CV-1-1-M14 AMT CV-1-2-M14 AMT CV-1-3-M14	AMT 2 S-1-1-M14	AMT 2 M-1-1-M14	AMT 2 L-1-1-M14
					AMT 2 S-1-2-M14	AMT 2 M-1-2-M14	AMT 2 L-1-2-M14
		5 Pin Plug	15 ft. (4.6 m) 28 ft. (8.5 m) 53 ft. (16.2 m)	AMT CV-1-1-M5 AMT CV-1-2-M5 AMT CV-1-3-M5	AMT 2 S-1-1-M5	AMT 2 M-1-1-M5	AMT 2 L-1-1-M5
					AMT 2 S-1-2-M5	AMT 2 M-1-2-M5	AMT 2 L-1-2-M5

*ONLY THE VELCRO MODEL WILL WORK FOR THE VALVED CKC150 AND THE VALVED FLEX-LOC TORCHES. CONTACT US FOR OTHER TIG MACHINES

TIG TORCHES & ACCESSORIES

TIG COLD WIRE FEEDERS

For complete installation of a cold wire TIG system, you need both the cold wire feeder and a TIG torch (hand held or machine mounted) with cold wire TIG capabilities. The cold wire TIG system works independently of a standard TIG power supply using normal TIG welding parameters.



Please specify wire size (0.030", 0.035", 0.045" or 1/16") and type Hard (Steel) or Soft (Aluminum)

Features:

- Increases productivity by up to 30%
- Automates adding of filler metal in TIG Welding
- All weld parameters can be duplicated
- Dual groove drive roll system accepts multiple wire sizes
- Uses standard wire spool sizes
- Eliminates TIG rod stub loss
- Cabinet keeps filler wire clean
- Makes fully automatic machine TIG welding possible
- Results are consistent high quality welds

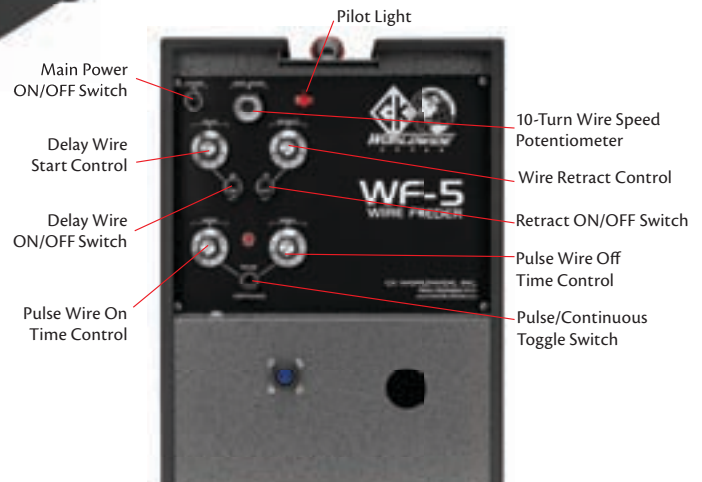

SPECIFICATIONS

Voltage:	115 V AC (220 V AC 50 Hz – Special Item)
Phase:	Single Phase
Frequency:	50/60 Hz
Height:	15"
Width:	10"
Length:	21"
Weight:	39 lbs.
Motor Type:	DC Permanent Magnet
Motor Rating:	1/3 HP at 4000 RPM
Filler Wire Spool Size:	12"
Filler Wire Sizes:	0.023", 0.030", 0.035", 0.045", 1/16"
Wire Feed Speed Range:	0 - 500 IPM
Feed Time (Pulsed Mode):	Continuously Variable
Dwell Time (Pulsed Mode):	Continuously Variable
Delay Start Time:	Continuously Variable
Wire Retract Time:	Continuously Variable

Mfg. No.	Drive Roll	Wire"
WF5-030	20 – 35DR	0.023 – 0.035
WF5-035	30 – 45DR	0.030 – 0.045
WF5-045	30 – 45DR	0.030 – 0.045
WF5-116	45 – 564DR	0.045 – 1/16

COLD WIRE FEED TORCHES

HAND HELD – WATER COOLED

- Semiautomatic TIG torches are hand torches
- Capability of delivering a continuous filler wire directly to the weld puddle
- Simplifies the skill level required as compared with manual feeding the filler rod
- Used in conjunction with the wire feeders
- **Pendant Unit** has an electric switch head style with straight wire guide and is used in conjunction with TIG torch
- Cold Wire torches come with rigid head without valve
- Available in 12 1/2" TriFlex/SuperFlex cable except model CWH3512 which comes with separate cables

Please specify wire size (0.030", 0.035", 0.045" or 1/16") and type Hard (Steel) or Soft (Aluminum)

Mfg. No.	Description	Amps	Length"	Head Accessories
CWH	Hand Held Pendant	-	-	-
CWHTL312	Rigid Cold Wire Torch	350	8	3 Series
CWH3512	Rigid Cold Wire Torch	400	9 1/2	3 Series
CWH1812	Rigid Cold Wire Torch	180	8 1/8	8 Series
CWH2312	Rigid Cold Wire Torch	300	8 1/4	2 Series

MACHINE MOUNTED – WATER COOLED

- Automatic TIG torches are machine torches
- Capability of delivering a continuous filler wire directly to the gas tungsten arc puddle
- Complete automatic feeding of the filler wire when torches are used in conjunction with the wire feeder
- 12 1/2"
- 1 3/8" O.D. barrel

Please specify wire size (0.030", 0.035", 0.045" or 1/16") and type Hard (Steel) or Soft (Aluminum)

Mfg. No.	Amps	Length"	Head Accessories	Head Style	Cable
CWM2312	300	18	2 Series	Straight Barrel	TriFlex
CWM3512	350	18	3 Series	Straight Barrel	Separate
CWMT412	400	4 1/16	3 Series	Face Plate Mounted	Separate
CWMT512	500	7	3 Series	7" Barrel	Separate



CWH



CWH3512



CWM2312



CWMT412

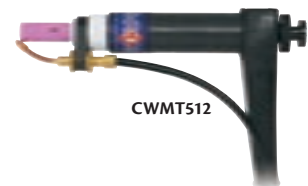

CWMT512

TURBO-SHARP® X TUNGSTEN ELECTRODE GRINDERS

An enclosed electrode grinder, which eliminates grinding dust exposure to both the user and the environment.

- Multifunctional cover - Through a slot in the cover, one can flatten the electrode to prepare a truncated cone
- 3 position adjustment for triple lifetime of grinding disc
- Angles adjustable from 20° to 60°
- Both sides of grinding disc coated with diamond-powder, giving double wheel life
- Allows exact repetition of longitudinal grinding
- Can be connected to vacuum system, accessory included with unit
- Can be equipped with an optional head which can grind electrodes of diameter: 0.040" (1.0 mm), 5/32" (4.0 mm), 3/16" (4.8 mm) or 1/4" (6.4 mm)
- Short tungsten kit grinds tungsten as short as 3/4" and includes 0.040" (1.0 mm), 1/16" (1.6 mm) and 3/32" (2.4 mm) collets

Model No.	Mfg. No.	Description	Price /Each
TTT401	TS10	115V Grinder	1857.00
TTT402	TS10-230	230V Grinder	2303.00
821-3707	TS3-W	Replacement Diamond Coated Disc Wheel	149.00
TTT413	TS3-HB	Grinder Head - 0.040" - 1/8" (included in TTT401)	358.00
821-3706	TS3-HR	Grinder Head - 0.040" - 5/32", 3/16", 1/4"	358.00
TTT414*	TS3-STK	Short Tungsten Kit	215.00

* For use with 821-3706 grinder head only

Both side of disc are coated with diamond-powder (double lifetime)

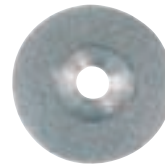

821-3707

TTT414

Short tungsten kit

(Sold separately)
Grinds electros as short as 3/4"(19 mm)



Includes: 0.040" (1.0 mm), 1/16" (1.6 mm) and 3/32" (2.4 mm) collets

3 position adjustable head!



Grinding disc last 3x longer!

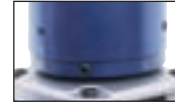

Turbo-Sharp®



TTT401



METAL CARRYING CASE INCLUDES:

- Standard head for diameters: 0.040" (1.0 mm), 1/16" (1.6 mm), 3/32" (2.4 mm) and 1/8" (3.2 mm)
- Accessory for stationary mounting
- Adapter for vacuum cleaning
- Pen style electrode holder
- Multifunctional cover
- Tools for assembling and replacement of grinding wheel
- User instructions



TECHNICAL DATA

Voltage:	120 V or 230 V AC
Single Phase:	60 Hz
Power:	400 W
Amp:	3.5 A
No load speed:	30 000 RPM
Weight:	3.7 lbs. (1690 g)
Guarantee:	2 years

MT200-AC/DC TIG WELDING SYSTEM

CREATE, REPAIR & CUSTOMIZE

- Provides the ability to quickly and efficiently adapt to dynamic welding situations
- High-performance dual voltage inverter for 115V and 220V
- Two dynamic welding modes: GTAW (TIG) and SMAW (Stick)
- Easy-to-use interface allows for quick setting adjustments
- Compact, portable design for use in multiple applications
- Features square wave technology allowing arc to start as low as 5 amps
- 3-year limited warranty

- **Use to Weld:** Aluminum, Titanium, Magnesium, Stainless Steel, Low Alloy Steel, Deoxidized Copper, and much more!
- **Includes:** CK17 Flex-Head Gas-Cooled TIG Torch with 12.5' Super Flex™ Cable, Dinse® Connector, AK-3 Accessory Kit, Foot Pedal Amperage Control, Ground Clamp with 12.5' Cable, Single-Flow Regulator, 6' Argon Hose, 220V to 115V power adapter



Model No.	Mfg. No.	Input Power Voltage/Phase/Hz	Input Current	Output Current Range		Rated Output		Price Each
				GTAW	SMAW	GTAW	SMAW	
TTV224	MT200-AC/DC	115/1/50/60	21A	115V: 5-140 Amps	115V: 10-110 Amps	115V: 140A@15.6V, 40% duty cycle	115V: 110A@24.4V, 25% duty cycle	4129.00
		220/1/50/60	34A	220V: 5-200 Amps	220V: 10-160 Amps	220V: 200A@18.0V, 25% duty cycle	220V: 160A@26.4V, 30% duty cycle	

TIG TORCHES & ACCESSORIES

TUNGSTEN ELECTRODES

- Oxides used are primarily zirconium, thorium, lanthanum or cerium
- Additions are 1% - 4%, improve arc initiation, especially when direct current (DC) welding is employed
- Thorium oxide (thoria), effective in terms of long life and thermal efficiency
- Zirconium oxide (zirconia) has been commonly used for alternating (AC) TIG welding, welding aluminum
- Electrode length: 7"
- **Each package contains 10 electrodes**

TYPE:

2% THORIATED:

- Good current capacity, arc stability and easy arc start on DC current
- High resistance to weld pool contamination
- Maintains sharpened tip configuration
- Not normally used on AC current because it is difficult to maintain the balled end

0.8% ZIRCONIATED:

- Excellent for AC welding due to the higher arc stability
- High-resistance to weld pool contamination
- Excellent balled end retention
- Handles higher current with less spitting
- Better arc starts and arc stability than pure tungsten

1.5% LANTHANATED:

- Lowest erosion rate
- Wide current range
- No spitting
- Best DC arc starts and stability

2% CERIATED:

- Excellent arc starting, stability, long life and higher-current capacity than thoriated tungsten
- Operate successfully with AC or DC current
- Non-radioactive
- Low erosion rate
- Wide current range
- No spitting

PURE:

- Lowest current capacity and least expensive
- Maintains a clean balled end for welding on AC
- More prone to weld contamination than other types of tungsten electrodes
- Tends to spit at higher currents
- Used for non-critical welds only

2% LANTHANATED:

- Non-radioactive
- Best general purpose electrode at medium to higher amperages for both A/C or D/C using inverter or transformer based constant current power sources
- Good for low-alloyed steels, non corroding steels, aluminum alloys, magnesium alloys, titanium alloys, nickel alloys, and copper alloys
- Good arc starts and stability, low erosion rate, medium to high current range

LAYZR™:

- Non-radioactive
- Best for automated or robotic applications in A/C or D/C due to low voltage tolerance (changes in tip to work piece distance) using inverter or transformer based constant current power sources
- Good for low-alloyed steels, non corroding steels, aluminum alloys, magnesium alloys, titanium alloys, nickel alloys, and copper alloys
- Very stable tip geometry runs cooler than 2% thoriated, longer life
- Very best low amperage starts

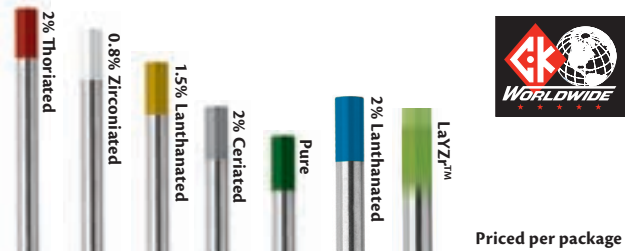

Model No.	Mfg. No.	ISO Colour Chart	Dia."	Price /Each
2% THORIATED				
TTT403	T0207GT2	Red	0.020	2.63
NP552	T0407GT2	AWS A5.12 EWTh-2	0.040	10.80
NP544	T1167GT2	ISO 6848 WT20	1/16	25.10
NP545	T3327GT2		3/32	56.80
NP543	T187GT2		1/8	101.00
714-1150	T5327GT2		5/32	161.00
0.8% ZIRCONIATED				
TTT408	T0207GZ	White	0.020	2.96
TTT409	T0407GZ	AWS A5.12 EWZr-8	0.040	11.80
NP546	T1167GZ	ISO 6848 WZ8	1/16	26.60
NP547	T3327GZ		3/32	59.80
NP553	T187GZ		1/8	106.00
714-1185	T5327GZ		5/32	169.00
1.5% LANTHANATED				
TTT404	T0207GL	Gold	0.020	2.96
TTT405	T0407GL	AWS A5.12 EWLa-1.5	0.040	11.20
714-1200	T1167GL	ISO 6848 WL15	1/16	25.60
714-1205	T3327GL		3/32	58.20
714-1210	T187GL		1/8	104.00
TTT406	T5327GL		5/32	165.00
2% CERIATED				
TTT407	T0207GC2	Grey	0.020	2.63
NP548	T0407GC2	AWS A5.12 EWCe-2	0.040	10.80
NP549	T1167GC2	ISO 6848 WC20	1/16	25.10
NP550	T3327GC2		3/32	56.80
NP551	T187GC2		1/8	101.00
714-1177	T5327GC2		5/32	161.00
PURE				
TTT410	T0207G	Green	0.020	2.63
NP539	T0407G	AWS A5.12 EWP	0.040	10.50
NP540	T1167G	ISO 6848 WP	1/16	23.70
NP542	T3327G		3/32	54.20
NP541	T187G		1/8	96.30
714-1060	T5327G		5/32	153.00
2% LANTHANATED				
TTV117	T0207GL2	Blue	0.020	2.63
TTV118	T0407GL2	AWS A5.12 EWLa-2	0.040	10.80
TTV119	T1167GL2	ISO 6848 WLZ0	1/16	25.10
TTV120	T3327GL2		3/32	56.80
TTV121	T187GL2		1/8	101.00
TTV122	T5327GL2		5/32	161.00
LAYZR™				
TTV111	T0207GTM	Chartreuse (Lime Green)	0.020	2.63
TTV112	T0407GTM	AWS A5.12 EWG	0.040	10.80
TTV113	T1167GTM	ISO 6848	1/16	25.10
TTV114	T3327GTM		3/32	56.80
TTV115	T187GTM		1/8	101.00
TTV116	T5327GTM		5/32	161.00

CHEM-SHARP

CHEMICAL TUNGSTEN SHARPENERS

- Safest way to sharpen tungsten without grinding
- Chemically mills a perfect point on pure, thoriated or titanium type tungsten
- Repoint time is approximately one minute at the work station
- Extends tungsten life four times longer than that of ground tungsten
- 5 oz. net jars, over 500 sharpenings per jar



Model No.	Mfg. No.	Description	Price /Each
881-1300	DF600-6	Jar, 5 oz. net	16.80
881-1305	DF601-6	Tungsten Holder	29.70
881-1310	DF602-4	Kit w/1 Jar and Holder	48.50

TUNGSTEN STICK-OUT GAUGES

- Made of durable solid brass
- Easily lock-in, correct stick-out from the end of nozzle
- Face of gauge marked in 1/16" indications for easy calculation of required stick-out
- Consistent stick-out adds quality to every weld
- Repeatable for welder to welder

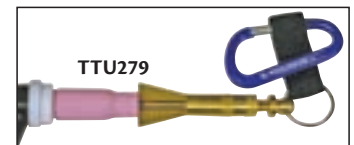

Model No.	Mfg. No.	Description	Price /Each
TTU279	TG1	For Standard Torch	50.60
TTU280	TG1-24	For 24 Series and Micro Torch	48.10

FOLD-A-JACK® HI JACKS

- 1" square tube base construction
- Quick-action lock washer for quick height positioning
- Patented Fall Guard™ feature allows 1" safety zone around lock washer
- 1 1/2" Acme fine adjustment thread handle, the largest in the industry
- Large, convenient adjustment handle
- Set screw for double margin of safety, can lock jack head to stand for transportation, no loose pieces
- Perfect for work height on shapes or pipes 24" in diameter or smaller
- Carrying handle for ease of transporting
- Jack independently load tested for quality assurance
- 2500-lb capacity
- CE rated

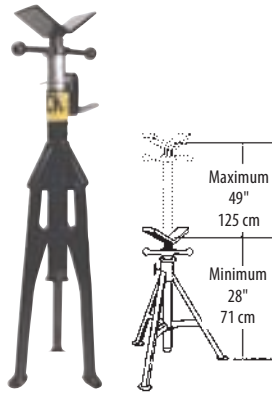

SUMNER

HEAD STYLES



Model No.	Mfg. No.	Description	Price /Each
432-1161	781300	ST-881 w/Vee-Head	140.00
432-1162	781301	ST-882 w/Roller Head	186.00
432-1163	781302	ST-883 w/Bar Stock Head	280.00
432-1164	781303	ST-884 w/Stainless Steel Rollers	234.00
432-1166	781304	ST-885 w/Stainless Steel Vee-Head	205.00
432-1167	781305	ST-886 w/Ball Transfer Head	268.00
432-1168	781306	ST-887 w/Rubber Wheels	207.00

POCKET PRO LEVELS

- Extra strong magnet will hold it firmly to any steel surface
- Two stationary vials are placed at 90° angles of each other and can be read from any surface of the level
- Vials are easily replaced if broken
- Dial is in 2 1/2° degree increments with spring tension for easy operation
- 9" long and 1 1/2" wide for easy handling and storage
- Pitch to degree conversion scales

Model No. 496-1185
Mfg. No. PP-200
Price/Each \$114.00



flange wizard tools

See page 1281 for our line of Levels



QWIK PINS SETS

- For fast, accurate alignment of carbon steel pipe flanges
- Quick installing pins work to level flange (two-hole) for tack and weld-out
- Hardened tapered Qwik Pins automatically center on 5/8" to 1 5/8" (16 - 42 mm) holes
- Features Acme threads for maximum clamping power and hardened steel for long-lasting use



SUMNER

Model No.	Mfg. No.	Price /Each
TTU664	781235	110.00



FLANGE LEVELERS

- Now two-hole and level in one time-saving operation
- Uses push-button Qwik Pins set nuts for fast action
- Features stub Acme threads for maximum clamping and hardened steel for lasting use
- Automatically centers in flange holes 5/8" to 1 5/8"
- Easily replaceable vials in the event of breakage



SUMNER

Model No.	Mfg. No.	Description	Price /Each
TTU665*	781240	Flange Leveler	166.00
TTU666	779934	Vial Kit	21.70

*Priced per set



POCKET LEVELS

- A twin vial level constructed of tough ABS and aluminum frame
- Strong magnetic base makes this pocket size level great for many tasks:
 - Can be used with a plumb bob
 - Level pipe for fit-up
 - Earth magnet on base and side to hold measuring tape
- Weights only 3 oz.



SUMNER

Model No.	Mfg. No.	Price /Each
TTU667	781947	9.70



VERSA LEVELS

- Featuring a tough, anodized body and a magnetic base
- Four vials - 0°, 30°, 45°, and 90°
- V-cut into the base for pipe and conduit work
- Thumb screw connects to pipe or bent conduit



SUMNER

Model No.	Mfg. No.	Price /Each
TTU668	781945	41.20

QUAD LEVELS

- Tough, anodized aluminum level with a magnetic base
- Four vials - 0°, 30°, 45°, and 90°
- V-cut into the base for pipe and conduit work
- Length: 8 1/2"



SUMNER

Model No.	Mfg. No.	Price /Each
TTU669	781946	45.60



PIPE LAYOUT MEASURING TOOLS

CONTOUR® #1 MARKER

Made from durable, lightweight aluminum

- Curv-O-Mark® Contour® Marker is a compact, time-saving tool used to lay out pipe and structural steel joints
- Laterals at any angle, tees, wyes, crosses, elbows
- Any type or size of joint can be quickly and precisely laid out
- No more complicated mathematical formulas or needless material waste
- Can be used to lay out pipe from 1-1/2" to 18" diameter, or structural steel members up to 18"
- Consists of an X-shaped frame, calibrated protractor, and a triple-jointed marking arm and holder
- Holder accepts a soapstone crayon (included), felt pen or pencil
- Frame easily folds into a compact tool that fits into a pocket or carrying case
- Can be used right side up or upside down, depending on the direction of the line to be scribed
- Protractor calibrated on both sides—one in degrees, the other in rise-inches-per foot-to service any type of measurement need
- Optional combination adaptor accessory allows the marker to lay out joints on larger size pipe, as well as scribe compound angles with just one setting

Model No. 430-2000

Mfg No. 14771

Price/Each \$122.00

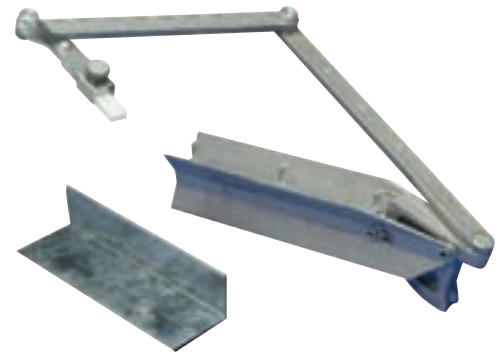

CONTOUR® #14 CIRCLE-ELLIPSE PROJECTORS

- Easily makes perfect circles, ellipses or oblong circles on any irregular flat or round surface
- Features a protractor with sliding rods and an adjustable lever to lock in the specified layout
- Strong, 20-lb pull magnetic base holds the projector in position during layout
- Durable web strap (included) holds the unit secure on non-magnetic surfaces and can be used on either side of the vertical column
- Lay out lateral intersections of different diameter pipes, or to project circles from 1 1/2" to 18" diameter on flat surfaces intersecting at angles from 0° to 70° from vertical
- Attachments to develop larger diameter circles are available
- Includes: Soapstone crayon and also works with chalk, pencil or steel scribe

Model No. 430-2110

Mfg. No. 14784

Price/Each \$276.00

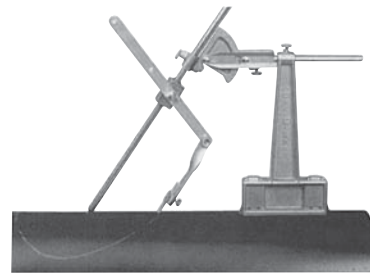

CONTOUR® RADIUS MARKERS

- Available in four sizes for scribing circles up to 80" diameter
- Folding type design—three smaller models will fit conveniently into a shirt pocket
- All have sturdy friction joints to maintain rigidity and accuracy
- Made from lightweight, rustproof aluminum for long wear
- Soapstone crayon installed in each radius marker
- Scribe holder will accept round, square or flat soapstone crayon, pencil or steel point scribe



Model No.	Mfg. No.	Description	Radius"	Price /Each
430-2580	14780	Mini	Up to 8	19.70
430-2590	14781	Small	Up to 20	28.10
430-2600	14782	Standard	Up to 24	29.60
430-2610	14783	Jumbo	Up to 40	48.60

CONTOUR® CENTERING HEADS

Aid in the setting of centerlines, establishing angles and marks for butt-ins, locating points inside pipes and tanks, laying out keyways and measuring declivity.



#6 Standard Model

- Used on pipe 1/2" to 4" diameter or larger
- Fitted with an adjustable dial bubble protractor (DSL), manually operated centering pin

#7 Jumbo Model

- For pipe 1" diameter and up
- Includes DSL
- Spring-loaded hardened centering pin eliminates the need for a hammer
- Align and press the trigger



Model No.	Mfg. No.	Type	Head Type	Head Width"	Price /Each
430-2050	14775	Standard	Y	4	64.20
430-2070	14776	Jumbo	Y	8	101.00

CONTOUR® #32 FLANGE ALIGNER BASES

- Removes the difficulty of flange aligning and squaring
- Holds square in the needed position without tying up one's hands
- Notched at either end for ease in aligning on the centreline of the pipe and has two 25 lb-pull, cast-in magnets for holding either a flat horizontal or vertical position
- Accepts either leg of a standard or combination square and will work on pipe diameters from 1" up, requiring only extension of the legs of the square being used to accommodate larger diameters
- Made from lightweight, durable aluminum



Model No. 430-2230

Mfg. No. 14795

Price/Each \$112.00

CONTOUR® #8 PRO-MAG LEVELS

- Made from cast aluminum
- Lightweight, easy-to-use tool for determining angles
- 360° adjustable DSL with two 90° quadrants graduated in 2-1/2° increments
- Cast-in tables used to convert degree-of-angle to rise-in-inches-per-foot or millimetres-per-meter
- Groove on the bottom edge permits use on a small pipe
- Ideal for pipe fitter, welder, jig builder or anyone who has to determine angles or do setup work
- Includes two cast-in 25-lb pull magnets that hold securely to any steel surface
- 9" L x 2" H x 3/4" Thick

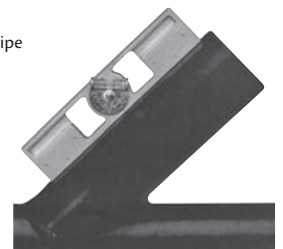

Model No. 430-2080

Mfg. No. 14777

Price/Each \$59.30

PIPE LAYOUT MEASURING TOOLS

CONTOUR® #33 UNIVERSAL LEVELS

- Multipurpose tool
- Designed primarily for pipefitting applications, is a valuable tool for any craft required to use a level or plumb bob
- Unit features a 360° adjustable protractor dial set level bubble (DSL) that ensures accurate levelling and permits the following additional uses:
 - Setting a predetermined pitch of a string of pipe
 - Setting the angle of laterals to a precise degree
 - Trueing vertical runs
 - Two-holing flanges
- Permits hands-free levelling, for tight spots
- Bubble is mounted on a protractor dial allowing for the level to be used in any position and still read accurately
- One face of the level is magnetic but both faces have deep, cast-in grooves that make the level self-centering on the contour of the pipe
- Magnets are cast-in, they do not interfere with the use of the level on non-magnetic materials, such as aluminum, copper, lumber, stone or other materials requiring levelling

- Comes with a two-threaded, self-aligning conical spacer and conical nut and bolt units for aligning pipe flanges (two-holding)
- Designed to fit any size bolt hole spaced between 2-1/4" to 8" centres on flanges permitting the orientation of flange bolt holes for any size pipe
- Includes: Two cast-in 25-lb magnets (exerting a 50-lb pull) to securely hold the unit in place on any steel surface, including the underside of a pipe or beam

Model No. 430-2240
Mfg. No. 14796
Price/Each \$101.00

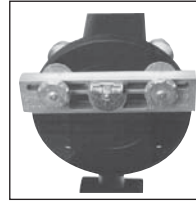

CONTOUR® WRAP-A-ROUNDS

- An inexpensive tool for marking straight lines around pipe, or for use as a straight edge
- Made of flexible gasket material
- Resistant to heat and cold
- Asbestos free with service temperature of up to 350°F
- Printed with a scale in inches, pitch chart, tangent chart and other useful markings except X-small
- 3.88" and 5.00" wraps feature a metric scale and pitch chart



Model No.	Mfg. No.	Size	Dimensions			Pipe Dia."	Price /Each
			L'	x	W"		
430-2330	14752	Medium	4	x	3.88	3 to 6	11.10
430-2370	14753	Large	6	x	3.88	3 to 10	11.90
430-2410	14754	X-Large	7	x	5.00	4 to 12	16.40
430-2450	14756	XX-Large	9	x	5.00	6 to 16	23.90
430-2490*	14757	Special	Length desired	x	3.88	-	2.46
430-2520*	14758	Special	Length desired	x	5.00	-	3.64
430-2550*	14759	Special	Length desired	x	7.00	-	5.46

*Special lengths available up to a maximum of 375'

CONTOUR® #28 MAGNETIC BURNING GUIDES

- Designed for use with a burning torch or as a straight edge
- Cast of strong, durable material to withstand heat and spatter
- Base has three 30-lb. pull cast-in magnets for use in any position
- 24" blade on a raised plane is standard

Model No. 430-2190
Mfg. No. 14791
Price/Each \$64.20



ATTACHMENTS FOR PRO-MAG BURNING SQUARE & MAGNETIC BURNING GUIDE

- Each is in two sections



Model No.	Mfg. No.	No.	Overall Length"	Price /Each
430-2200	14792	29	34	62.30
430-2210	14793	30	48	60.10
430-2220	14794	31	72	94.50

STEEL HAND STAMPS

- For hand-held, hammer struck applications
- Manufactured from high quality steel
- Induction hardened for added durability and extended life
- Bevelled striking edge prevents breakage and accidents during use
- Stamping end is hardened at 58-62 HRC and the striking end is hardened to 38-43 HRC to prevent splintering
- Letter sets contain 27 pieces, "A" through "Z" and "&"-ampersand
- Number sets contain 9 pieces, "0" through "9", numbers "6" and "9" are interchangeable

aurora tools®



Model No.	Stamp Size"	Type	Price /Each
TLZ389	1/8	Number	13.95
TLZ392	1/8	Letter	38.85
TLZ390	3/16	Number	22.80
TLZ393	3/16	Letter	55.40
TLZ391	1/4	Number	29.60
TLZ394	1/4	Letter	72.35

CONTOUR® WORKER KITS

All the top sellers in one case!

- Includes: #1 Contour® Marker, #7 Centering Head, #8 Pro-Mag level, standard Radius Marker, square soapstone, holder and lockable metal carrying case

Model No. TTT484
Mfg. No. 20664
Price/Each \$280.00



WELDING BLANKETS & SCREENS

24-OZ. FIBREGLASS LAVASHIELD™ WELDING BLANKETS

- 24-oz. black fiberglass with neoprene coated on both sides
- Hemmed on all sides with Kevlar® thread that has been double-locked stitched
- Large brass grommets added for extra durability and easy handling
- Temperature resistance: 1000°F (538°C)

Applications: Heavy-duty vertical curtain protection against sparks, molten metal splash, welding spatter and grinding spray. General purpose drop cloth for protection against welding spatter.



Model No.	Dimensions'	Price /Each
NT896	6 x 6	102.00
NT821	6 x 8	132.00

30-OZ. FIBREGLASS LAVASHIELD™ WELDING BLANKETS

- 30-oz. gold fibreglass with neoprene coated on both sides
- Hemmed on all sides with Kevlar® thread that has been double-locked stitched
- Large brass grommets added for extra durability and easy handling
- Temperature resistance: 1000°F (538°C)

Applications: Heavy-duty drop cloth and vertical curtain protection against sparks, molten metal splash, welding spatter and grinding spray.



Model No.	Dimensions'	Price /Each
NT822	6 x 6	120.00
NT823	6 x 8	155.00

18-OZ. SILICA LAVASHIELD™ WELDING BLANKETS

- 18-oz. Sahara brown silica fabric
- Hemmed on all sides with Kevlar® thread that has been double-locked stitched
- Large brass grommets added for extra durability and easy handling
- Temperature resistance: 2192°F (1200°C)

Applications: General purpose drop cloth and vertical curtain protection against extremely high temperature sparks, molten splash, welding spatter and grinding spray.



Model No.	Dimensions'	Price /Each
NT824	3 x 3	65.00
NT825	6 x 6	215.00

WELDING BLANKETS

- Weldflex specially coated cloth, combination of aramid and silica fibres
- Treated to enhance shedding of molten metal splash generated by most severe welding or furnace operations
- Highly abrasion resistant, exceptional strength and durability, good heat resistance
- Soft, pliable and non-irritating
- Sheds welding spatter and molten metal up to 3000°F on a 15°-20° incline
- Protects objects and machinery while welding

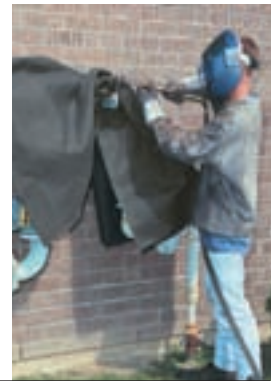

Model No.	Mfg. No.	Dimensions'	Price /Each
SF063	FB-020-0505	5 x 5	196.00
SF064	FB-020-0506	5 x 6	234.00
SF065	FB-020-0507	5 x 7	276.00
SF066	FB-020-0508	5 x 8	316.00
SF067	FB-020-0509	5 x 9	355.00
SF068	FB-020-0510	5 x 10	395.00

WILSON* WELD-O-GLASS WELDING BLANKETS

- 24-oz. black fibreglass, vermiculite coated
- Heavy-duty, general purpose welding blankets
- Provides protection from sparks, spatter and slag
- Temperature resistance: 1200°F
- ANSI FM-4950 certified for use in vertical applications

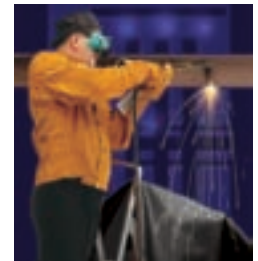

Model No.	Mfg. No.	Dimensions'	Price /Each
146-3100	37595	3 x 3	25.10
146-1312	36302	6 x 6	74.80
146-1367	36318	6 x 8	102.00

WILSON* FLAMESHIELD SOLDERING & WELDING PADS

- Made of carbon felt
- Protects walls, joints and wall studs from burn damage associated with low-temperature soldering
- An excellent blanket for weld sparks and spatter
- A must for every toolbox and maintenance service vehicle



Model No.	Mfg. No.	Dimensions"	Price /Each
TTV108	36678	9 x 12	25.10

WILSON* WELDING UMBRELLAS

- Provides protection from inclement weather
- Features lightweight aluminum frame and tilt mechanism
- Made of Rip-Stop vinyl which is water-resistant, fire-retardant and very tear-resistant



Model No.	Mfg. No.	Dimensions	Price /Each
		Dia' x H'	
146-2050	36684	6.5 x 7	150.00

WELDING BLANKETS & SCREENS

COMBOFRAME ADJUSTABLE MODULAR WELDING SCREENS

FRAMES

- Innovative COMBOframe combines high durability with extreme versatility
- Made with heavy-duty finished steel tubing and connects with spring-pins
- Assembles in less than five minutes, no tools required
- Adjustable to fit both 6' and 8'-wide welding screens
- Includes 360° swivel connectors that allow various configurations

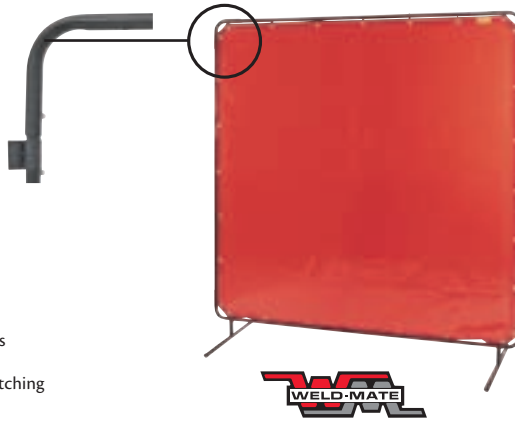

LAVASHIELD™ CURTAINS

- Specially formulated 16-mil thick vinyl
- **NT832** and **NT833**: 25-mil thick cotton duck canvas
- Grommets every 12" interval
- Screen edges are hemmed with DuPont® Kevlar® stitching
- Resists to UV rays, flame and abrasion
- **Sold per panel**

CURTAINS & FRAMES

Model No.	Dimensions			Transparency	UV Resistance	Colour	Price /Each	CURTAINS ONLY	
	W'	x	H'					Model No.	Price /Each
NT888	6	x	6	High	Moderate	Yellow	149.00	NT826	39.95
NT889	8	x	6	High	Moderate	Yellow	159.00	NT827	49.95
NT890	6	x	6	High	Moderate	Orange	149.00	NT828	39.95
NT891	8	x	6	High	Moderate	Orange	159.00	NT829	49.95
NT892	6	x	6	Moderate	Moderate	Green	149.00	NT830	39.95
NT893	8	x	6	Moderate	Moderate	Green	159.00	NT831	49.95
NT894	6	x	6	Opaque	Maximum	Olive	209.00	NT832	105.00
NT895	8	x	6	Opaque	Maximum	Olive	235.00	NT833	135.00

FRAMES ONLY

Model No.	Description	Price /Each
NT834	Modular Frame, Adjustable Width 6' or 8'	115.00

OPTIONAL CASTERS

Model No.	Description	Price /Each
SEB618*	2" Rubber Caster with Brake	6.10

*Sold individually, two casters required per frame's foot

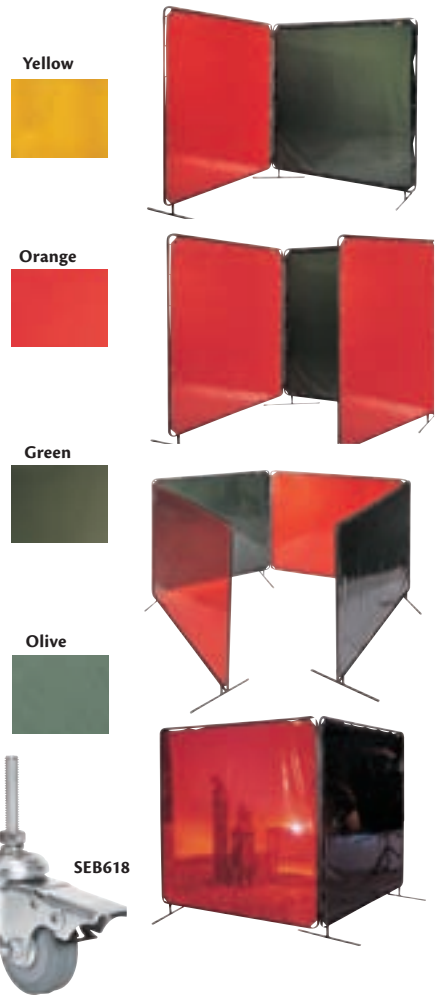

WILSON* WELDING SCREENS

- Comprised of 1" square steel tubing assembled with unique corner brackets for the toughest frame product available
- Minimizes frame wobble and sway
- Offer unique combination of strength, sturdiness and safety
- Orange Spectra see thru curtain filters 100% of far UV radiation and 100% of blue light
- Heavy-duty 14-mil vinyl film minimizes arc glare
- Custom sizes available
- **Sold per panel**

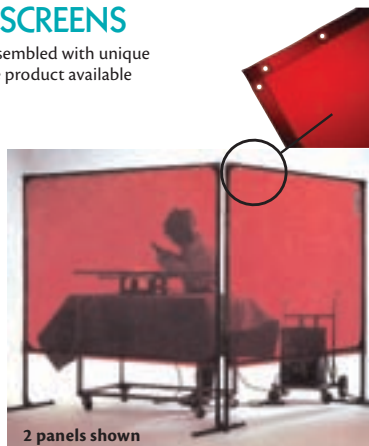

Model No.	Mfg. No.	Dimensions W' x H'	Price /Each
CURTAINS & FRAMES			
TTV105	-	6 x 6	149.00
TTV106	-	8 x 6	170.00
TTV107	-	10 x 6	190.00
FRAME ONLY			
TTV099	36336	6 x 6	105.00
TTV100	36338	8 x 6	112.00
TTV101	36333	10 x 6	117.00
CURTAIN ONLY			
TTV102	36219	6 x 5	44.20
TTV103	36256	8 x 5	58.40
TTV104	36193	10 x 5	73.60

WELSAFE® NO. 447

- Dramatically reduces fatigue while withstanding the challenges of welding environments
- Specially formulated to repel sparks and hot metal shards, the thick rubber surface has a melt point of over 500°F
- The super resilient Nitricell® sponge base is a nitrile rubber composite that offers unparalleled comfort
- All edges are safety bevelled
- 9/16" thick
- Green rating > 33% post industrial material
- Colour: Black

3-YEAR WARRANTY



Anti-fatigue mat specifically designed for welding!

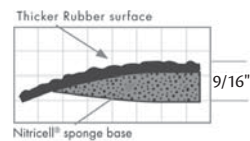

Model No.	Dimensions W' x L'	Price /Each
NG181	2 x 3	83.60
NG182	3 x 5	209.00

WELDING HELMETS & LENSES



FLEXIBLE FRAME GOGGLES

- Soft PVC frame seals out light leaks
- Choice of 2" x 4 1/4" fixed front or flip front design
- Comes complete with shade 5 lens



Model No.	Description	Price /Each
NT646	Fixed Front	6.25
NT647	Flip Front	8.25

CUP GOGGLES

- Rigid 2" (50 mm) round lens cup goggle
- Comes complete with shade 5 lens



Model No.	Price /Each
NT648	6.30

V-MAXX™ GOGGLES

- Sleek wrap-around styling
- Direct vent for impact resistance and indirect vent for chemical splash applications
- Peel-off goggle covers available to extend useful life of the lens
- OTG compatible
- 180° clear field of vision
- Lenses coated with Fog-ban® anti-fog coating
- Pivoting headband clips to adjust strap around hardhats or hearing protection
- Adjustable elastic or neoprene headband
- Certified to CSA standard Z94.3



by Honeywell



SAI907

Model No.	Mfg. No.	Description	Lens Tint	Price /Each
SAI907*	11250830	Indirect Vent, Black Frame and Headband	Shade 3.0	13.89
SAI908*	11250850	Indirect Vent, Black Frame and Headband	Shade 5.0	16.31
SAI905*	11250800	Direct Vent, Red Headband	Clear, Fog-ban®	6.01
SAI906	11250810	Indirect Vent, Black Neoprene Headband	Clear, Fog-ban®	7.10
SAI909	11250860	Goggle Covers, 10/pkg	-	7.58

* Elastic Headband

JACKSON SAFETY* V80 WILDCAT* GOGGLES

- Extreme heat resistance, will not melt, drip or ignite at 350°F for five minutes
- Adjustable side vents to help increase airflow
- Fits naturally to the contour of your face
- Lightweight and comfortable with a pivot headband that allows for optimal placement
- Meets ANSI standard Z87.1+ and compliant with CSA standard Z94.3



Model No.	Mfg. No.	Lens Tint	Price /Each
TTT946	20525	Clear Anti-Fog	13.30
TTT947	20526	Smoke Anti-Fog	13.70
TTT948	20527	Amber Anti-Fog	13.70
TTT949	20528	Shade 3.0 Anti-Fog	19.60
TTT950	20529	Shade 5.0 Anti-Fog	19.60

JACKSON SAFETY* V90 SHIELD* GOGGLES

- Features the Monogoggle® XTR® with indirect ventilation and a polycarbonate shield for full face protection
- Shield detaches from the goggles
- Curved face shield conforms to shape of face offering added protection
- Can be used over most prescription eyeglasses
- Meets ANSI impact standard Z87.1+



Model No.	Mfg. No.	Lens Tint	Price /Each
TTT954	18629	Clear Anti-Fog	25.10
TTT955	18631	Shade 3.0 Anti-Fog	34.00
TTT956	18633	Shade 5.0 Anti-Fog	34.00

JACKSON SAFETY* WELDING HELMETS

Design to perform in a range of welding conditions, the Jackson Safety* welding helmets brand are available in a variety of materials including fibreglass and vulcanized fibre. Choose from a selection of filters – from passive to digital ADF platforms and numerous graphic designs to reflect personal style. WH series tiers highlight increasing levels of performance within the Jackson Safety* welding helmets product line.

JACKSON SAFETY* WH40 SMARTIGER* BALDER* WELDING HELMETS

- Internal adjustable shade 9-13
- Internal adjustable sensitivity
- Aerodynamic shell designed for better fume deflection
- Solar-powered unit with two arc sensors
- Can be used for torch cutting
- Lightweight at 19.2 oz
- Auto-on ADF is always ready to weld
- Meets ANSI standard Z87.1 and compliant with CSA standard Z94.3
- 5-year warranty

SEH126



SEH127



Model No.	Mfg. No.	Description	Price /Each
SEH126	37188	SmartIGer* Balder* Black	243.00
SEH127	37187	SmartIGer* Balder* Torch Dancer	267.00
SDL094	37247	External Safety Lens, 10/Pkg.	22.10
SDL095	37249	Internal Safety Lens, 10/Pkg.	11.10

JACKSON SAFETY* WH70 BH3* BALDER* WELDING HELMETS

- Superior angle of view
- Enhanced visibility and colour recognition
- Variable shade 9-13, adjustable sensitivity and opening time delays
- Solar-powered unit with two arc sensors
- Curved front cover plate offers reduced heat build-up, reflections and fogging
- Aerodynamic shell designed for better fume deflection
- Can be used for torch cutting
- Quick and easy replacement of safety plates
- Lightweight at 19.84 oz.
- Auto-on ADF is always ready to weld
- Meets ANSI standard Z87.1 and compliant with CSA standard Z94.3
- 5-year warranty

SEH125



Model No.	Mfg. No.	Description	Price /Each
SEH125	37191	BH3* Black	489.00
SDL094	37247	External Safety Lens, 10/Pkg.	22.10
SDL096	37248	Internal Safety Lens, 10/Pkg.	11.10

JACKSON SAFETY* WH70 TRUESIGHT* II DIGITAL ADF WELDING HELMETS

DELIVERS BEST-IN-CLASS OPTICAL CLARITY BY INTRODUCING BALDER* TECHNOLOGY TO TRUESIGHT* II'S LARGE VIEWING AREA AND DIGITAL CONTROLS

- Optical classification 1/1/1/1 rating
- Variable shade from 5-8 and 9-13
- 3.25" x 4.00" viewing area
- Digital controls (Designed by welders for welders)
- Weld, grind and torch modes (3-N-1 welding helmet)
- Delay and sensitivity adjustments
- Four sensors and auto off
- Meets ANSI standard Z87.1 and compliant with CSA standard Z94.3
- DIN rating EN379



SEC603



Model No.	Mfg. No.	Description	Price /Each
SEC603	29371	HLX w/Truesight* II Digital ADF, Black	504.00
SEC604	30319	Truesight* II ADF Cartridge 4 1/2" x 5 1/4"	462.00
SEC605	30320	External Safety Lens	3.15
SEC606	30321	Internal Safety Lens	2.09

Can't find what you're looking for?



Call us today!

WELDING HELMETS & LENSES

JACKSON SAFETY* WH30/WH40 ELEMENT* ADF WELDING HELMETS

- Lightweight shell weighs only 6 oz.
- Available in two different auto-darkening filters: ADF fixed shade 10 and ADF variable shade 9-13
- Two independent arc sensors
- Solar powered unit
- Meets ANSI standard Z87.1 and compliant with CSA standard Z94.3



SEA769



Model No.	Mfg. No.	Description	Price /Each
WH30 ELEMENT*			
SEA770	23286	Welding Helmet-Fixed Shade 10 ADF, 4.33" x 3.54"	70.60
SEA772	23440	Replacement Cover Lens Kit - Includes 5 Front and 2 Rear Safety Plates	6.36
WH40 ELEMENT*			
SEA769	23282	Welding Helmet-Variable ADF, 4.33" x 3.54"	106.00
SEA771	29127	Replacement Cover Lens Kit - Includes 5 Front and 2 Rear Safety Plates	6.12

JACKSON SAFETY* WH40 NITRO* VARIABLE ADF WELDING HELMETS

- Offers welders outstanding features at an economical price point
- Variable shade 9-13, sensitivity and delay adjustments
- Lightweight - Only weighs 1 pound fully assembled
- Three independent sensors
- Solar powered
- Meets ANSI standard Z87.1 and compliant with CSA standard Z94.3



SAS083



Model No.	Mfg. No.	Description	Price /Each
SAS083	21931	Nitro* Blue w/Nitro* ADF	142.00
SAS084	21947	Nitro* ADF Cartridge, 4.33" x 3.54"	93.50
SEA270	20696	370 Series Headgear	25.60
SEA573	22603	Replacement Cover Lens Kit - Includes 5 Front and 2 Rear Safety Plates	6.39
SAS086	21119	24-Pc. Back Cover Plate, 5/Bag	14.40

JACKSON SAFETY* ELEMENT* REPLACEMENT HEADGEARS

- Teeth are automatically disengaged during adjustment
- Compatible with Element* helmets only

Model No. SED982
Mfg. No. 23442
Price/Each \$11.90



JACKSON SAFETY* WH40 INSIGHT* VARIABLE ADF WELDING HELMETS

- Get the high-level elements of a high-performance welding lens without the high price
- Offers an ADF with digital and multi-function controls for any welding job
- Sensitivity and delay adjustments
- Four independent sensors
- Easy-to-use digital controls
- Torch, grind and weld modes
- Variable shade: 9-13
- Viewing area: 3.93" x 2.36"
- Meets ANSI standard Z87.1 and compliant with CSA standard



Model No.	Mfg. No.	Description	Price /Each
SDP562	40710	HSL100 Black w/Insight* ADF	202.00
SDP563	40709	Insight* ADF Cartridge, 4.5" x 5.25"	172.00
SDP564	41594	Internal Lens, 10/Pkg.	11.20
SDP565	41589	Replacement Cover Lens Kit - 5 Front and 2 Rear Safety Plates	9.71

JACKSON SAFETY* R60 AIRMAX WELDING POWERED AIR PURIFYING RESPIRATOR SYSTEMS

- Powered air purifying respirator offers affordable protection from harmful contaminants while you weld
- Features a WH40 series variable auto-darkening filter, adjustable shade 9-13 with light shade 4
- Flame retardant face-seal protects against sparks
- Lightweight blower unit mounts on adjustable waist belt
- Audible alarm signals user when battery charge or new filter is required
- Flame retardant breathing hose
- Lightweight lithium ion battery provides eight hours of power
- NIOSH approved HE filtration from particulate contaminants



Model No.	Mfg. No.	Description	Price /Each
SED529	12993	R60 Airmax PAPR	778.00
SED532	13043	ADF Protective Plates (5 Fronts, 2 Backs)	8.62
SED535	13051	Replacement Battery	161.00
SED536	13053	Replacement HE Filter	139.00

Other replacement parts are available

SEE PAGES 470-481 FOR PAPR OPTIONS

WELDING HELMETS & LENSES

WELDING HELMETS

- Lightweight design with ratchet headgear
- Comes complete with shade 10 lens
- Choice of 2" x 4 1/4" flip front or 4 1/2" x 5 1/4" wide vision fixed front

NT645



NT687



Model No.	Description	Window Dimensions"	Price /Each
NT645	Flip Front	2 x 4 1/4	18.95
NT687	Fixed Front	4 1/2 x 5 1/4	26.65

JACKSON SAFETY* WH10 PASSIVE WELDING HELMETS

- Narrow shell design is perfect for work in tight space
- Extended front increases throat protection against sparks, slag and other physical hazards
- Comes standard with cover plate and shade 10 polycarbonate filter plate
- Meets ANSI standard Z87.1 and compliant with CSA standard Z94.3

SD617



PB193



Model No.	Mfg. No.	Description	Colour	Price /Each
HSL-2 HELMETS - 2" X 4 1/4"				
PB193	14982	Flip Front	Black	50.70
SD618	14983	Flip Front	Blue	53.20
HSL-100 HELMETS - 4 1/2" X 5 1/4"				
SD617	14975	Fixed Front	Black	53.40
SAN172	14976	Fixed Front	Blue	48.80

JACKSON SAFETY* WH20 860P LEATHER WELDING HELMETS

- Ideal for use in confined spaces
- Tough, pliable, breathable leather covering
- Flip-front glass holder, 2" x 4 1/4"
- Includes adjustable headgear



Model No.	Mfg. No.	Price /Each
141-1120	14531	113.00

JACKSON SAFETY* WH20 H500 FIBREGLASS HANDSHIELD

- For quick inspection, providing guidance and monitoring robotic welds
- Designed for high-heat applications
- Features fibreglass helmet with injection-molded plastic handle
- Fixed front, 5 1/4" x 4 1/4"
- Must purchase a filter prior to use
- Meets ANSI standard Z87.1



Model No.	Mfg. No.	Price /Each
SAN181*	14967	45.80

*Lens plates sold separately

JACKSON SAFETY* 370 SERIES REPLACEMENT HEADGEAR

- Removable comfort cradle is a pivoting head pad that conforms to any head size
- 3-position slider adjusts distance of the lens from your eyes for precise vision
- Crown strap adjustment allows the headgear to be raised or lowered for maximum comfort and performance
- Sweatband helps absorb perspiration
- Vertical lock-in eliminates helmet creeping
- Compatible with HaloX, Nitro*, Nexgen*, Master 3-N-1, Solera, Truesight*, Boss* 3-N-1 and Professional welding helmets



Model No. SEA270
Mfg. No. 20696
Price/Each \$25.60



JACKSON SAFETY* HELMET BAGS

- Made of heavy-duty denier fabric with drawstring closure
- Features velcro close front lens pocket and two side mesh tool pockets
- Fits all Jackson Safety* helmets

Model No. TTU304
Mfg. No. 18935
Price/Each \$24.00



OFFICE PRODUCTS

INSTRUMENTS, SCALES & ELECTRICAL

SHIPPING & PACKAGING

TOOLS & EQUIPMENT

WELDING & METALWORKING

SAFETY EQUIPMENT & SUPPLIES

JANITORIAL & MAINTENANCE

MATERIAL HANDLING & STORAGE

WELDING HELMETS & LENSES



ALL OPTREL® HELMETS:

- Use a combination of LCD technology and solar cells eliminating the need for On/Off switches
- Provide full time IR/UV protection at all times in the unlikely event of a cartridge failure
- Water resistant to IP76 standards against humidity and moisture
- Meet worldwide safety standards including CSA, ANSI and DIN



P550 WELDING HELMETS

- External controls enable welders to manually adjust their shade level
- Sensitivity Control prevents ADF from responding too soon or not at all to their arc flash
- Opening Delay function allows welders to adjust the time it takes to switch from dark to light
- Bright helmet color combinations, side panel designs add personalization, visibility in dark environments
- Shade level 4/9-13
- Grind mode shade 4
- Power by solar cells and two lithium batteries
- Application range: all electric arc welding processes
- Prohibited for overhead welding and laser/gas welding
- Complies with CSA standard Z94.3
- 2-year warranty



ACCESSORIES

Model No.	Mfg. No.	Description	Qty/Pkg.	Price/Each
COVER LENSES				
SAX006	5000.001	Inside Cover Lenses	5	13.10
SED552	5000.250	Front Cover Lenses	5	16.80
MAGNIFICATION LENSES				
SAX008	5000.050	1.00 Diopter	1	37.80
SAX009	5000.051	1.50 Diopter	1	37.80
SAX010	5000.052	2.00 Diopter	1	37.80
SAX011	5000.053	2.50 Diopter	1	37.80

HELMETS

Model No.	Mfg. No.	Description	Colour	Price /Each
SED542	1007.000	Unpainted (No Side Cover)	Black	369.00
SED543	1007.010	Reptile Side Cover	Black/Green	386.00
SED544	1007.020	Bulldog Side Cover	Black/White	386.00
SED545	1007.030	Tiger Side Cover	White/Black	386.00
SED546	5012.700	Replacement Auto-Darkening Filter	-	302.00

E600 SERIES WELDING HELMETS

- Offers the widest range of shade levels available in an autodarkening welding helmet
- External controls enable welders to manually adjust their shade level without removing helmets
- Curved helmet design deflects smoke, particles, and other debris, and is ideal for overhead welding
- Sensitivity Control prevents ADF from responding too soon or not at all to their arc flash
- Opening Delay function allows welders to adjust the time it takes to switch from dark to light
- Sensor Slide allows the detection angle to be reduced from 120° to 60°
- Grind mode shade 4
- Powered by solar cells and two lithium batteries
- Approved for overhead welding
- Complies with CSA standard Z94.3

e650

- Shade Level 4/9-13



e684

- Adaptive shade autopilot automatically adjusts the shade level as one welds
- Third sensor detects changes in arc intensity and adjusts shade level accordingly
- Twilight ADF technology restores light more naturally, presenting a smoother transition to the eye
- High definition viewing
- True colour filter optimizes view of colours in true form
- Curved helmet optimized for overhead welding
- Shade Level : 4/5-13



Model No.	Mfg. No.	Description	Colour	Price/Each
SAX003	1006.300	e650 Helmet	Black Unpainted	595.00
SAX004	1006.310	e650 Helmet	Red	595.00
SAX005	5012.440	Replacement Auto-Darkening Filter	-	524.00

Model No.	Mfg. No.	Description	Colour	Price/Each
SF1934	1006.500	e684 Helmet	Silver	778.00
SF1935	5012.480	Replacement Auto-Darkening Filter	-	696.00

e680

- True colour filter optimizes view of colours in almost true form, allows welders to easily read red LEDs without raising their helmets
- Shade levels 4/5-9 & 9-13



Model No.	Mfg. No.	Description	Colour	Price/Each
SAW997	1006.143	e680 Helmet	Black	795.00
SE1954	1006.110	e680 Helmet	Dark Blue	795.00
SAW996	1006.180	e680 Helmet	Medium Blue	795.00
SE1955	1006.160	e680 Helmet	Green	795.00
SAW998	5012.400	Replacement Auto-Darkening Filter	-	670.00

ACCESSORIES

Model No.	Mfg. No.	Description	Qty /Pkg.	Price /Each
SAM897	5000.210	Front Cover Lenses	2	20.60
SAM898	5000.212	Front Cover Lenses	5	47.80
SAX006	5000.001	Inside Cover Lenses	5	13.10
SAX008	5000.050	Magnification Lens, 1.00 Diopter	1	37.80
SAX009	5000.051	Magnification Lens, 1.50 Diopter	1	37.80
SAX010	5000.052	Magnification Lens, 2.00 Diopter	1	37.80
SAX011	5000.053	Magnification Lens, 2.50 Diopter	1	37.80
616-1570	5003.250	Replacement Headgear	1	49.10

WELDING HELMETS & LENSES

VEGAVIEW2.5 WELDING HELMETS

- Brightest view in light state and grind mode at shade level 2.5
- Shade level 2.5/8-12
- External infinite shade level adjustment enables welders to manually adjust their shade level from 8-12
- True colour filter optimizes view of colours in true form
- Sensitivity control prevents ADF from responding too soon or not at all to their arc flash
- Opening delay allows welders to adjust the time it takes to switch from dark to light
- Curved helmet optimized for overhead welding
- Meets CSA standard Z94.3
- 2-year warranty



Model No.	Mfg. No.	Description	Colour	Price /Each
SF1930	1006.600	vegaview2.5 Helmet	Black Unpainted	569.00
SF1931	5012.470	Replacement Auto-Darkening Filter	-	521.00

ACCESSORIES

Model No.	Mfg. No.	Description	Qty/Pkg.	Price/Each
SAM898	5000.212	Front Cover Lenses	5	47.80
SAM901	5000.300	Inside Cover Lenses	5	12.80

WELDCAP®

- Combines the lightweight wear comfort of a baseball cap with full protection of an ADF welding helmet
- Lightweight, flame-retardant textile is soft where it must be comfortable, robust plastic is rigid where it must be tough
- Well-defined nose cut out places the lens closer to the eyes, enlarges the welder's line of sight by 2.7 times
- Weighs less than 14 ounces
- Sleek profile ideal for welder working in confined spaces
- Grind mode shade 3
- Shade level 3/9-12
- Meets Z87.1+ standard for impact resistance



Model No.	Mfg. No.	Description	Qty /Pkg.	Price /Each
SEK224	1008.000	Weldcap®	1	334.00
SEK225	5000.260	Front Cover Lens	5	38.60
SEK226	5000.040	Inside Cover Lens	5	15.20
SEK227	5002.700	Nose Clip	2	15.20
SEK228	5002.800	Replacement Textile Cap	1	117.00
SEK229	5002.720	Battery Cover	2	13.60
SEK230	5002.900	Parking Buddy Belt Clip	1	37.40

HELMET ACCESSORIES

HARD HAT ADAPTERS

- Simply remove existing headgear from any Optrel® helmet and install adapter
- For use with the majority of popular hard hat models
- Slip-on/off spring assembly for easy installation



Model No.	Mfg. No.	Description	Price /Each
SAN048	5011.180	Fits all non-slotted hard hats	36.90
SED541	5011.185	Fits all slotted hard hats	47.10

LEATHER CHEST PROTECTORS

- Ensures the safety of welder's chest region
- Clip attachment grips the rim of helmet
- Provides secure fit while eliminating the need for velcro-type attachments on shell



Model No.	Mfg. No.	Description	Price /Each
SAN051	4028.015	Fits all Optrel® helmets	78.90

LEATHER NECK PROTECTORS

- Covers the entire lower neck and back regions of head
- Clips on to the rim of the helmet shell



Model No.	Mfg. No.	Description	Price /Each
SAN049	4028.016	Fits all Optrel® helmets	129.00

OTHER ACCESSORIES

- **Sweatbands** - For use with all Optrel® helmets
- **Helmet Back Pack** - Back-pack style



Model No.	Mfg. No.	Description	Qty /Pkg.	Price /Each
SAN046	5004.073	Front Sweatbands	2	8.90
SDP288	5004.020	Back Sweatbands	2	8.90
SEK875	9410.043.00	Helmet Back Pack	1	25.20

NOVA AUTO-DARKENING FILTERS

- Automatically darken to shade 10
- Fits most competitive 2" x 4 1/4" openings
- Solar powered
- 2-year warranty



Model No.	Mfg. No.	Price /Each
SAJ757	5012.238	252.00

Safety Products for Industry

WELDING HELMETS & LENSES

SPEEDGLAS™ 100 SERIES VARIABLE AUTO-DARKENING FILTER WELDING HELMETS

- Provides outstanding optical clarity
- Three selectable sensitivity levels for reliable arc detection
- Light state shade 3
- 1.73" x 3.66" viewing area
- Available in women helmets which feature an ergonomic headband that accommodates smaller head sizes
- Stick, MIG and most TIG welding processes
- Ideal for hobby welders, farmers, as well as maintenance and construction workers
- Approved to CSA standard Z94.3 and meets the requirements of Z87.1 for Eye and Face Protection
- Approved for most Stick, MIG, and TIG applications greater than 10 amps



SEJ927



SEJ928



SEJ097



SEJ099



ACCESSORIES

Model No.	Mfg. No.	Description	Colour	Shade	Price /Each
SEJ927*	07-0012-31BL	Helmet w/ADF Variable	Black	8 - 12	349.00
SEJ928	07-0012-31WP-CA	Helmet w/ADF Variable	Wild-N-Pink	8 - 12	422.00
SEJ097	07-0000-31	Cartridge Only, ADF 100V Variable	-	8 - 12	283.00

* Hardhat adapter included. (Hardhat sold separately)

Other graphic designs available, including NHL authorized logo helmets

Model No.	Mfg. No.	Description	Qty /Pkg.	Price /Each
SAN353	04-0290-00	Inner Cover Plate	5	13.60
SEJ098	07-0200-51	Outside Protection Plate	10	32.20
SEJ099	07-0014-00NR	Hard Hat Adapter	1	65.70
SEJ117	07-0680-00	Magnifying Lens Holder	2	26.70

SPEEDGLAS™ SUPER LIGHT (SL)WELDING HELMETS

- 25% lighter than other Speedglas™ helmets
- Narrowest helmet, making it ideal for welding in very tight spaces
- Light state shade 3 with four sensitivity levels
- Speedglas™ SL filter offers automatic on/off switching for quick welding tasks
- Superb arc detection is ideal for specialty welding such as TIG
- 1.68" x 3.57" viewing area
- Weight: 13 oz. (including filter)



SAQ961



SAQ962



Model No.	Mfg. No.	Description	Shade	Price/Each
SAQ961	05-0013-41	Helmet w/ADF Variable	8 - 12	487.00
SAQ962	05-0000-41	Cartridge Only, ADF Variable	8 - 12	442.00

ACCESSORIES

Model No.	Mfg. No.	Description	Qty /Pkg.	Price /Each
SAN353	04-0290-00	Inner Cover Plate	5	13.60
SEJ100	05-0250-00	Outside Protection Plate	5	33.90
SEJ118	05-0680-00	Magnifying Lens Holder	1	27.60

SPEEDGLAS™ 9100 SERIES WELDING HELMETS

- Designed for optimal comfort and protection
- Head suspension changes not only how you wear the helmet, but also how you experience fit, stability and balance
- Smooth up-and-down pivot action that gently locks in the "up" position and the suspension keeps the helmet closer to user's head
- Light state shade 3 with five sensitivity levels
- Sensitivity adjustment allows for use with all Stick, MIG and TIG welding processes, with grinding and torch modes
- Feature a built-in mag plate holder and seven user selectable dark shades
- Available with shade 5 SideWindows to increase peripheral vision
- Filters available in different sizes, 9100V and 9100XX, 30% larger than any other Speedglas™
- Designed with the professional welder in mind
- Approved to CSA standard Z94.3



SEJ102



SEJ105



SEJ103



SEJ106



SEJ110



ACCESSORIES

Model No.	Mfg. No.	Description	Viewing Area"	Shade	Price /Each
9100V					
SEJ101	06-0100-10	Helmet w/ADF Variable	1.8 x 3.7	5, 8 - 13	484.00
SEJ102	06-0100-10SW	Helmet w/SideWindows and ADF Variable	1.8 x 3.7	5, 8 - 13	484.00
SEJ103	06-0000-10	Cartridge Only, ADF Variable Shade	-	5, 8 - 13	449.00
9100XX					
SEJ104	06-0100-30	Helmet w/ADF Variable	2.8 x 4.2	5, 8 - 13	699.00
SEJ105	06-0100-30SW	Helmet w/SideWindows and ADF Variable	2.8 x 4.2	5, 8 - 13	699.00
SEJ106	06-0000-30	Cartridge Only, ADF Variable Shade	-	5, 8 - 13	694.00

Model No.	Mfg. No.	Description	Qty /Pkg.	For Use W/Helmets	Price /Each
SEJ107	06-0200-10	Inside Protection Plate	5	9100V	15.40
SEJ108	06-0200-30	Inside Protection Plate	5	9100XX	19.40
SEJ109	06-0200-51	Outside Protection Plate	10	9100V, 9100XX	36.80
SEJ110	06-0014-00NR	Hard Hat Adapter	1	9100V, 9100XX	78.70
SEJ111	06-0400-51	Replacement Headgear	1	9100V, 9100XX	30.40



3M™ POWERED AIR RESPIRATORS

- High efficiency particulate respiratory protection system for welders
- Welding helmet 9100-Air with auto-darkening filter offers the welder compact, lightweight respiratory protection and quality filter optics all-in-one
- SideWindows: Shade 5 side filters that increase peripheral vision
- Ergonomic, adjustable head suspension for increased comfort, helmet stability and weight distribution
- Selectable shades 5, 8-13 and Shade 3 light state; grinding and tack modes
- 5-position sensitivity control • Adjustable recovery delay • Solar panel
- Storage bag, do-rag and starter kit included
- Meets ANSI Z87.1 and approved to CSA Z94.3 for eye and face protection
- Approved for use in all stick, MIG and TIG applications
- Breathing tube is SG-30W
- Offers assigned protection factor (APF) of 25 when used as a NIOSH-approved system
- Lens Type: Variable
- PAPR Battery Life Time: Up to 12 Hours



SDM014



REPLACEMENT FILTERS & CARTRIDGES

Model No.	Mfg. No.	Viewing Area L" x W"	ADF Battery Life Time (hrs)	Solar Cell	Price /Each
SDM014	35-1101-10SW-CA	1.8 x 3.7	2800	Yes	2279.00
SDM016	35-1101-30SW-CA	2.84 x 4.2	2000	Yes	2512.00

Model No.	Mfg. No.	Description	Price /Each
SAN357	15-0009-99X02	2-pack Adflo™ Spark Arrestor	15.30
SAN358	15-0099-99X06	6-pack Adflo™ Prefilter	21.80
SAN359	15-0099-99X12	12-pack Adflo™ Prefilter	39.70
SAN360	15-0199-99X02	2-pack Adflo™ HE Particle Filter	153.00
SAN361	15-0199-99X06	6-pack Adflo™ HE Particle Filter	71.00
SAN362	15-0199-99X36	36-pack Adflo™ HE Particle Filter	2438.00
SAN363	15-0399-99X02	2-pack Adflo™ OV/SD/CL/HC Cartridge	231.00
SAN364	15-0399-99X06	6-pack Adflo™ OV/SD/CL/HC Cartridge	636.00

SPEEDGLAS™ ACCESSORIES

- **Protective bag** used to help protect the Speedglas™ helmets assembly when not in use
- **Full hood** for use with Speedglas™ welding helmets to provide additional protection to the user from welding spark and spatter on the top portion of the head, neck and shoulders
- Hood is made of 75% FR cotton and 25% Kevlar synthetic fiber



SEJ119



SEE884

Model No.	Mfg. No.	Description	Price /Each
SEJ119	06-0500-65	Protective Bag	39.10
SEE884	06-0700-83	Full Hood	155.00

SPEEDGLAS™ 9100 HEADGEARS

DESIGNED FOR OPTIMAL COMFORT

- Conforms to head to help increase stability, improve weight distribution and significantly reduce pressure on head
- Self-adjusting headband and swivels to fit different head shapes
- Articulating ratchet adjustment
- Four settings to determine distance between face and helmet for optimum viewing
- Includes assembly parts



SEJ111



Model No.	Mfg. No.	Price /Each
SEJ111	06-0400-51	30.40

SEE PAGES 454-457 FOR 3M RESPIRATORS



WELDING HELMETS & LENSES



FILTER PLATE LENSES

- Provides ultimate protection against ultraviolet and infrared rays present during the welding process
- Attenuates varying proportions of ultraviolet, visible and infrared rays in conformance with industry standards
- Precision ground and edged to allow a proper and safe fit
- Optically correct and precisely shaded
- Hardened glass

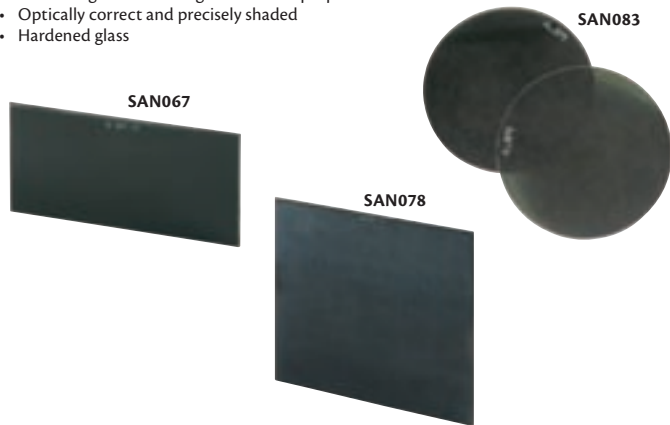

Model No.	Mfg. No.	Shade	Price /Each
2" x 4 1/4"			
SAN061	FS-1H-4	4	1.18
SAN062	FS-1H-5	5	1.18
SAN063	FS-1H-6	6	1.18
SAN064	FS-1H-7	7	1.18
SAN065	FS-1H-8	8	1.18
SAN066	FS-1H-9	9	1.18
SAN067	FS-1H-10	10	1.18
SAN068	FS-1H-11	11	1.18
SAN069	FS-1H-12	12	1.18
SAN070	FS-1H-13	13	1.18
SAN071	FS-1H-14	14	1.18

Model No.	Mfg. No.	Shade	Price /Each
4 1/2" x 5 1/4"			
SAN073	FS-5H-5	5	2.99
SAN074	FS-5H-6	6	2.99
SAN075	FS-5H-7	7	2.99
SAN076	FS-5H-8	8	2.99
SAN077	FS-5H-9	9	2.99
SAN078	FS-5H-10	10	2.99
SAN079	FS-5H-11	11	2.99
SAN080	FS-5H-12	12	2.99
SAN081	FS-5H-13	13	2.99
SAN082	FS-5H-14	14	2.99
50 MM			
SAN083	FL-5H-4	4	3.90
SAN084	FL-5H-5	5	3.90

MAGNIFYING LENSES

- Makes a welder's work easier and more comfortable
- Useful for precision welding jobs
- Offers optically balanced magnifications in 0.25 increments
- 2" x 4 1/4"





Model No.	Diopter Strength	Price /Each
GLASS		
NT652	0.75	5.55
NT653	1.00	5.55
NT654	1.25	5.55
NT905	1.50	5.55
NT655	1.75	5.55
NT656	2.00	5.55
NT657	2.25	5.55
NT658	2.50	5.55
NT659	3.00	5.55

Model No.	Diopter Strength	Price /Each
PLASTIC		
SAN095	1.00	9.07
SAN096	1.25	9.07
SAN097	1.50	9.07
SAN098	1.75	9.07
SAN099	2.00	9.07
SAN100	2.25	9.07
SAN101	2.50	9.07

CLEAR COVER LENSES

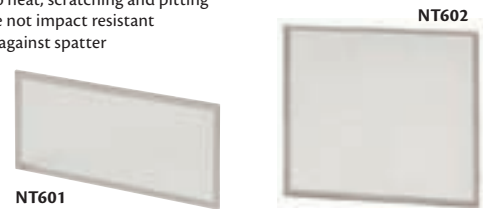
- Polycarbonate lenses are for eye protection against light impact such as sparks and small particles
- Cast resin lenses are also for eye protection and are more resistant to heat, scratching and pitting
- Clear glass lenses are not impact resistant and are only for use against spatter



Model No.	Mfg. No.	Size	Price /Each
POLYCARBONATE			
NT601		2" x 4 1/4"	0.52
NT602		4 1/2" x 5 1/4"	1.20
CAST RESIN			
SAN055	PP-2	2" x 4 1/4"	0.74
SAN056	PP-4	4 1/2" x 5 1/4"	1.95
SAN057	PL-5	50 mm	3.02
CLEAR GLASS			
SAN058	GP-2	2" x 4 1/4"	0.50
SAN059	GP-4	4 1/2" x 5 1/4"	0.84

OMNI-VIEW® GOLD FILTER PLATES

- Made of breakage resistant polycarbonate
- Allows welder to see more in clearer and natural colours
- Gold coating reflects harmful infrared generated by an arc, keeping eyes cooler and more comfortable

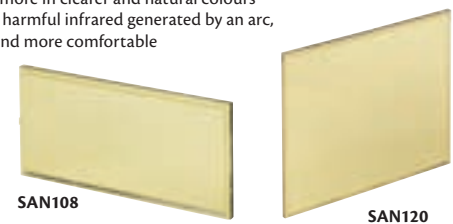

Model No.	Mfg. No.	Shade	Price /Each
2" x 4 1/4"			
SAN106	FP2G-8	8	11.60
SAN107	FP2G-9	9	11.60
SAN108	FP2G-10	10	11.60
SAN109	FP2G-11	11	11.60
SAN110	FP2G-12	12	11.60
4 1/2" x 5 1/4"			
SAN117	FP4G-8	8	28.90
SAN118	FP4G-9	9	28.90
SAN119	FP4G-10	10	28.90
SAN120	FP4G-11	11	28.90
SAN121	FP4G-12	12	28.90

MILLER®/HOBART® COMPATIBLE AUTO-CHANGE COVER LENSES

- Replacement lenses provide an effective and cost efficient method of protecting investment
- Made of 100% impact-resistant polycarbonate



Model No.	Mfg. No.	Type of Lens	Qty /Package	For Use with Helmets	Price /Each
TTU323	231410/770237	Inside/Outside	5	FS/XL/Xli/Xlix/Performance	9.80
TTU324	770240	Outside	5	XL/Xli	12.60
TTU325	770241	Outside	5	Xlix	12.60
TTU326	216327	Inside	5	Elite/Digital Elite	9.80
TTU327	216326	Outside	5	Elite/Digital Elite	13.60
TTU328	231410	Inside	5	Pro-Hobby	10.00
TTU329	231411	Outside	5	Pro-Hobby	12.80
TTU330	231921	Outside	5	Performance	12.80

Trademarks and trade names are the property of their respective owners

WELDERS' DEERSKIN TIG GLOVES

- Premium split deerskin leather construction
- Designed for precision welding applications
- Superior fit and dexterity
- Double thumb strap extends wear life
- 4" gauntlet cuff provides superior protection
- Exceptionally soft finish

Case Qty: 120

Model No.	Size	Price /Each
SM597	Small	17.60
SM598	Medium	18.10
SM599	Large	18.65
SM600	X-Large	19.15
SAP293	2X-Large	19.50



Priced per Pair



WELDERS' PIGSKIN TIG GLOVES

- Premium grain pigskin leather construction
- Designed for precision welding applications
- Excellent fit and dexterity
- Exceptional durability
- Double thumb strap extends wear life
- 4" gauntlet cuff provides superior protection

Case Qty: 120

Model No.	Size	Price /Each
SAN639	Small	13.15
SAN640	Medium	13.35
SAN641	Large	13.55
SAN642	X-Large	13.75



Priced per Pair



WELDERS' SOFTOUCH™ PIGSKIN TIG GLOVES

- Seamless index finger construction provides unobstructed control over small diameter welding rods and ultra light TIG torches
- Sewn with DuPont® Kevlar® thread for higher seam strength and seam flame resistance
- Extra long cuff offers wrist and forearm protection against heat
- 4" split pigskin cuff, seamless index finger

Case Qty: 72

Model No.	Size	Price /Each
610-2008M	Medium	22.00
610-2008	Large	23.00



Priced per Pair



WELDERS' STANDARD QUALITY GLOVES

- Rugged split cowhide leather construction
- Excellent abrasion resistance
- Full thermal cotton lining provides added heat protection
- Welted seams at all critical points

Case Qty: 72

Model No.	Description	Size	Price /Each
SAO130	Gloves	Large	8.50
SAO131	One-Finger Mitt	Large	8.75



Priced per Pair



WELDERS' SUPERIOR QUALITY GLOVES

- Top split cowhide leather construction
- Excellent abrasion resistance
- Double thumb strap extends wear life
- Full thermal cotton lining provides added heat protection
- Welted seams at all critical points

Case Qty: 72

Model No.	Description	Size	Price /Each
SAO128	Gloves	Large	11.55
SAP352	Gloves	X-Large	11.95
SAO129	One-Finger Mitt	Large	11.75



Priced per Pair



WELDING GLOVES



WELDERS' PREMIUM QUALITY GLOVES

- Premium split cowhide leather construction
- Excellent abrasion resistance
- Double thumb strap extends wear life
- Full thermal cotton lining provides added heat protection
- Welled seams at all critical points
- Sewn with Kevlar® thread to avoid burning



Priced per Pair



Case Qty: 72

Model No.	Size	Price /Each
SAN635	Large	12.50

WELDERS' PREMIUM QUALITY FOAM LINED GLOVES

- Premium split cowhide leather construction
- Excellent abrasion resistance
- Full reinforced thumb strap extends wear life
- Cotton covered foam lining provides superior heat protection
- Welled seams at all critical points
- Sewn with Kevlar® thread to avoid burning



Priced per Pair



Case Qty: 72

Model No.	Size	Price /Each
SAN277	Large	12.95

WELDERS' COMFOFLEX™ PREMIUM QUALITY GLOVES

- Heat and flame resistant shoulder split cowhide
- Fully sock lined for added comfort
- Kevlar® stitched welled seams
- 13 1/2" long with reinforced thumb



Priced per Pair



Case Qty: 72

Model No.	Size	Price /Each
610-0328	Large	19.00

WELDERS' COMFOFLEX™ PREMIUM LINED GLOVES

- Flame retardant, air cushioned, sweat absorbent lining
- Provides incomparable comfort and extra insulation
- Buck tan, heat resistant side split cowhide
- Kevlar® thread



Priced per Pair



610-2000

Case Qty: 72

Model No.	Description	Price /Each
610-2000	Welding Gloves	28.95
610-2178	One-Finger Mitts	29.95
610-2076	Pigskin Gloves	32.95

WELDERS' PIPELINER GLOVES

- Premium split cowhide leather exterior construction
- Full grain cowhide leather interior provides incomparable comfort
- Protective leather patch on back of left hand
- Excellent abrasion resistance
- Sewn with Kevlar® thread to avoid burning
- Reinforced thumb extends wear life



Priced per Pair



Case Qty: 72

Model No.	Size	Price /Each
SAV008	Large	19.95
SEB930	X-Large	20.95

WELDERS' PREMIUM COWHIDE TIG GLOVES

- Grain cowhide unlined palm
- Premium grain cowhide leather construction
- Unparalleled fit and dexterity with exceptional durability
- Weltd seams and straight thumb for expert control
- 4" gauntlet cuff provides superior protection
- Twaron® stitching improves seam strength and reduces seam burnout
- Designed for precision welding applications

Case Qty: 72



Priced per Pair

Model No.	Size	Price /Each
SDL992	Medium	16.95
SDL993	Large	16.95
SDL994	X-Large	16.95



WELDERS' HEAVY-DUTY GENERAL PURPOSE PREMIUM COWHIDE GLOVES

- Grain cowhide leather palm
- Premium grain cowhide leather construction with split cowhide leather palm
- Unlined palm for increased comfort and dexterity
- Fully weltd Twaron® stitched seams improves seam strength and reduces seam burnout
- 6" gauntlet cuff for increased protection
- Reinforced thumb extends wear life

Case Qty: 72



Priced per Pair

Model No.	Size	Price /Each
SDL995	Medium	18.95
SDL996	Large	18.95
SDL997	X-Large	18.95



WELDERS' COMFOFLEX™ PEARL DEERSKIN GLOVES

- 14 1/2" incredibly soft, genuine North American deer hides
- Flame retardant, air cushioned, sweat absorbent lining
- Thick pliable layer of protection that easily molds to your hand for added comfort
- Kevlar® thread

Case Qty: 40



Priced per Pair

Model No.	Size	Price /Each
610-2850	Large	65.00



PREMIUM HIGH HEAT HAND SHIELDS

- Aluminized PFR rayon reflects 95% radiant heat
- 5-ply DuPont® Kevlar® sewn and split cowhide backing for extra durability
- Leather and elastic strap system
- Sold individually

Case Qty: 144



Priced per Pad

Model No.	Description	Price /Each
SE549	Premium Hand Shield	11.00

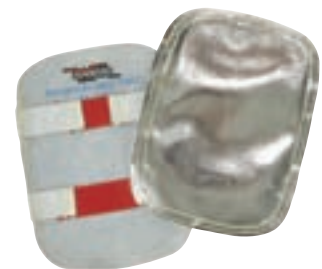

FABRICATOR GLOVES

- High-dexterity glove designed exclusively for intricate fabrication of sheet metal, welding and bodywork
- 100% genuine leather construction
- Three heat-resistant cowhide panels on heel, inside, and outer edge of palm
- Fingertip reinforcements on index, middle and ring fingers
- Dual-layer leather knuckle band
- Plush, suede deerskin top and fingers
- Stretch Kevlar® protective wedge insert
- Oversize, easy-entry, hook and loop closure
- CE approved

Case Qty: 120



Priced per Pair

Model No.	Mfg. No.	Size	Price /Each
SAN869	MFG-05-008	Small (8)	61.80
SAN870	MFG-05-009	Medium (9)	61.80
SAN871	MFG-05-010	Large (10)	61.80
SAN872	MFG-05-011	X-Large (11)	61.80
SAN873	MFG-05-012	2X-Large (12)	61.80



WELDING CLOTHING

LAVA BROWN LEATHER JACKETS

- Designed to allow complete body movement and freedom
- Heat and flame-resistant leather is made from durable side split cowhide
- Seams are double lockstitched
- Include full-sized pocket and multiple-snap adjustment cuffs
- Roll-up collar stops shooting spatter



Model No.	Size	Chest Measurements	Price /Each
TTU398	Medium	40-42"	165.00
TTU399	Large	44-46"	165.00
TTU400	X-Large	48-50"	165.00
TTU401	2X-Large	52-54"	180.00
TTU402	3X-Large	56-58"	195.00
TTU403	5X-Large	64-66"	225.00

LAVA BROWN LEATHER ACCESSORIES

- Designed to allow even weight distribution on the user to reduce fatigue
- Heat and flame-resistant leather is made from durable side split cowhide



Model No.	Size	Price/Each
A. SLEEVE		
TTU389	23" L, Pair	62.00
B. CAPE SLEEVES		
TTU407	Small	110.00
TTU405	Medium	110.00
TTU406	Large	110.00
TTU408	X-Large	110.00
TTU409	2X-Large	110.00
TTU410	3X-Large	130.00
C. BIBS		
TTU411	14" L	22.00
TTU412	20" L	30.00
D. SPLIT LEG APRONS & CHAPS		
TTU396	42" L	79.00
TTU397	48" L	92.00
TTU404	Chaps	85.00
E. WAIST APRONS		
TTU392	24" L	38.00
F. BIB APRONS		
TTU393	36" L	58.00
TTU394	42" L	64.00
TTU395	48" L	75.00
G. SPATS		
TTU390	6" L, Pair	29.00
TTU391	14" L, Pair	67.00



PROBAN WELDING JACKETS

COOL PROTECTION, COOL LOOK!

- Superior flame, heat and abrasion-resistant, select cowhide sleeves for heavy-duty protection
- 30" length jacket made of black 9-oz. Proban FR-7A flame-retardant cotton sateen for safety and cool comfort
- Five-snap closure front minimizes hot shooting spatter from entering
- Inside utility pocket for safety and convenience



Model No.	Size	Chest Measurements	Price /Each
TTV013	Medium	40-42"	77.00
TTV014	Large	44-46"	77.00
TTV015	X-Large	48-50"	77.00
TTV016	2X-Large	52-54"	83.00
TTV017	3X-Large	56-58"	92.00
TTV018	5X-Large	64-66"	106.00

GOLDEN BROWN LEATHER JACKETS

- Made of heat and abrasion-resistant select split cowhide
- Sewn with Kevlar® thread for added seam strength
- Roll-up collar with velcro closure and welted shoulder seams
- Reinforced double leather snap panel



Model No.	Size	Chest Measurements	Price /Each
TTU384	Medium	40-42"	109.00
TTU385	Large	44-46"	109.00
TTU386	X-Large	48-50"	109.00
TTU387	2X-Large	52-54"	119.00
TTU388	3X-Large	56-58"	129.00

FLAME RETARDANT CLOTHING

- Manufactured from flame-retardant treated cotton sateen
- Will retain its flame-retardant properties for up to 50 normal washings
- Specially-designed underarm sport cut and hemmed collar
- 9-oz. jackets include inside pocket and five snaps
- 9-oz. cape sleeves come with six snap fasteners for bib (sold separately)



Model No.	Size	Chest Measurements	Price /Each
JACKETS			
TTU998	Medium	40-42"	49.95
TTU999	Large	44-46"	49.95
TTV001	X-Large	48-50"	49.95
TTV002	2X-Large	52-54"	55.00
TTV003	3X-Large	56-58"	60.00
TTV004	5X-Large	64-66"	70.00
CAPE SLEEVES			
TTV005	Medium	40-42"	31.00
TTV006	Large	44-46"	31.00
TTV007	X-Large	48-50"	31.00
TTV008	2X-Large	52-54"	34.00
TTV009	3X-Large	56-58"	36.00
BIB & SLEEVES			
TTV010	20" Length Bib	-	11.50
TTV011	18" Long Sleeve, Pair	-	11.00
TTV012	23" Long Sleeve, Pair	-	13.50

WELDERS' CAPS

- Athletic mesh lining to allow sweat vapour to quickly evaporate
- Pre-shrunk and presoftened lightweight fabric, flame retardant until washed
- Air cushioned front lining for comfort and sweat absorbency
- **Sold per package**



Camo

Assorted styles include: Happy Hour, Nautical, Free Spirit, Safari, Paradise, Camo, Feast and Wild.

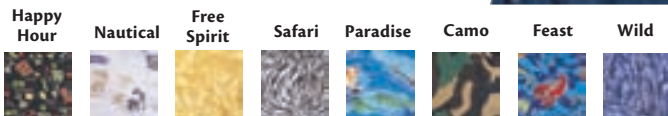

Model No.	Diameter	Qty /Pkg.	Price /Each
ASSORTED			
NT838	7 1/8"	12	65.00
NT839	7 1/4"	12	65.00
NT840	7 3/8"	12	65.00
NT841	7 1/2"	12	65.00
NT842	7 5/8"	12	65.00
CAMO			
NT843	7 1/8"	12	69.00
NT844	7 1/4"	12	69.00
NT845	7 3/8"	12	69.00
NT846	7 1/2"	12	69.00
NT847	7 5/8"	12	69.00

HEADGEAR PADS & SWEATBANDS

- Field tested to improve helmet grip with maximum perspiration absorption
- Headgear pads are flame retardant for added safety
- Made of an absorbent air cushioned layer lined with 10% fleece cotton
- Velcro fastening system is designed to fit all major brands of headgear
- Sweatbands come with elastic strap
- **Sold per package of two**



Suspender headgear



Sweatband



Non-suspender headgear

Model No.	Description	Price /Each
620-3200V	Suspender Pads For Use With Hard Hats	4.35
SAM548	Sweatbands	4.35
620-3100V	Non-Suspender Pads For Use With Welding Helmets	4.35

WELDERS' DOORAGS

- Athletic mesh lining to allow sweat vapour to quickly evaporate
- Pre-shrunk and pre-softened lightweight fabric, flame retardant until washed
- Air cushioned front lining for comfort and sweat absorbency
- Assorted styles
- One size fits all
- **Sold per package**



Camo



Free Sprit



Wild



Model No.	Assorted Styles	Qty /Pkg.	Price /Each
NT835	Camo, Wild, Safari	12	75.00
NT836	Happy Hour, Feast, Free Spirit	12	72.00
NT837	Authentic Woodland Camo	12	82.00

COTTON WELDERS' BEANIES

- 100% flame resistant cotton
- Added protection under welding helmet
- Two colours (black and white)
- One size fits all
- Imprint available with minimum quantity

Model No. SEE845
Price/Each \$1.35

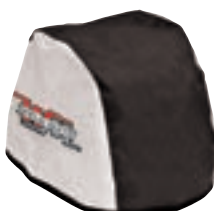

WELDING KNEE PADS

- Made of heat-resistant leather
- Flexible non-skid cap designed to stand up to the everyday demands of the welding environment
- Ideal for welding as well as high heat applications such as smelters and foundries
- **Sold per pair**

Model No. SM777 Mfg. No. 6991-01Q
Price/Each \$70.70

ALLEGRO INDUSTRIES



LEATHER KNEE PADS

- Tough abrasion-resistant leather for maximum protection and soft cushion back for comfort
- Elastic straps with velcro closures ensure a secure fit resistant to heat and fire
- Ideal for welders or any construction application such as concrete work
- **Sold per pair**

Model No. SAL218 Mfg. No. 6991
Price/Each \$39.20

ALLEGRO INDUSTRIES



SEE PAGES 532 - 555
FOR OUR FULL CLOTHING LINE

WELDING CLOTHING



STANDARD WELDING KITS

- Kit comes with complete gear bag
- **Kit Includes:**
 - Carbon steel scratch brush, long handle, 3 x 19
 - Chipping hammer, cone and chisel head with spring steel handle
 - MIG pliers, 8-way with nickel-plated finish
 - Flat soapstone holder with soapstone
 - C-clamp locking pliers with swivel pads
 - Locking welding clamps
 - Flip front shade 5 goggles, 2" x 4 1/4"
 - Safety glasses, meets or exceeds CSA Z94.3 standard
 - Cotton welders' beanie, one size fits all
 - Welders' gloves, split cowhide leather with full thermal cotton lining
 - Golden brown leather jacket
 - Welding helmet, flip front shade 10



Model No.	Jacket Size	Price /Each
TTV186	Medium	222.00
TTV187	Large	222.00
TTV188	X-Large	222.00
TTV189	2X-Large	231.00
TTV190	3X-Large	240.00

PREMIUM WELDING KITS

- Kit comes with complete gear bag
- **Kit Includes:**
 - Carbon steel scratch brush, long handle, 3 x 19
 - Chipping hammer, cone and chisel head with spring steel handle
 - MIG pliers, 8-way with nickel-plated finish
 - Flat soapstone holder with soapstone
 - C-clamp locking pliers with swivel pads
 - Locking welding clamps
 - Flip front shade 5 goggles, 2" x 4 1/4"
 - Safety glasses, meets or exceeds CSA Z94.3 standard
 - Cotton welders' beanie, one size fits all
 - Welders' gloves, top split cowhide leather with full thermal cotton lining
 - Proban jacket with leather sleeves
 - Welding helmet, variable ADF shade 9-13



Model No.	Jacket Size	Price /Each
TTV191	Medium	284.00
TTV192	Large	284.00
TTV193	X-Large	284.00
TTV194	2X-Large	290.00
TTV195	3X-Large	297.00

ULTIMATE WELDING KITS

- Kit comes with complete gear bag
- **Kit Includes:**
 - Carbon steel scratch brush, long handle, 3 x 19
 - Chipping hammer, cone and chisel head with spring steel handle
 - MIG pliers, 8-way with nickel-plated finish
 - Flat soapstone holder with soapstone
 - C-clamp locking pliers with swivel pads
 - Locking welding clamps
 - Flip front shade 5 goggles, 2" x 4 1/4"
 - Safety glasses, meets or exceeds CSA Z94.3 standard
 - Cotton welders' beanie, one size fits all
 - Welders' gloves, premium split cowhide leather with full thermal cotton lining
 - Lava brown leather jacket
 - Welding helmet, variable ADF solar-powered shade 9-13 with sensitivity and delay adjustments



Model No.	Jacket Size	Price /Each
TTV196	Medium	413.00
TTV197	Large	413.00
TTV198	X-Large	413.00
TTV199	2X-Large	428.00
TTV200	3X-Large	442.00

FLEX WELDING GRADE ERGONOMIC CHAIRS

- Ergonomic chair that reduces pressure sensations felt in the buttocks, wrists and lumbar region
- Reduces fatigue by limiting muscular effort
- Five 3" caster wheels adaptable to all surfaces
- Flame retardant natural cow suede
- Dual-density cushions and closed-cell foam padding
- Backrest: 12" W x 15.5" H
- Seat: 15" L x 18" W
- Standard Pneumatic Lift: 16" to 21"
- Colour: Black
- Material: Suede
- Weight Capacity: 300 lbs.
- Overall Dimensions: 19" L x 27" W x 21" H

Model No. OP275
Price/Each \$645.00



SYNETIK
design

STAG4 WELDING GRADE ERGONOMIC BENCHES

- Ergonomic seat allows users to work in a kneeling position with comfort
- Reduces pressure sensations felt in the knees, ankles and lumbar region
- One lever mechanism for seat height adjustment and 20° adjustable slope for kneeling position
- Padding: Dual-density cushions and closed-cell foam
- Upholstery: Flame retardant natural cow suede
- Standard pneumatic lift: 16" to 21"
- Dimensions of knee rest: 8.5" W x 15.5" L
- Dimensions of seat: 12.5" W x 12" L
- Five 3" caster wheels that are adaptable to all surfaces
- Includes tool tray
- Colour: Black
- Material: Suede
- Weight Capacity: 300 lbs.
- Overall Dimensions: 20" L x 28" W x 21" H

Model No. OG348
Price/Each \$767.00



SYNETIK
design

ROD HOLDERS

- Double leather bottom and metal swivel clip
- 5-ply Kevlar® stitched with rivet reinforcement

Model No. NP519
Price/Each 9.60



ER70S6 CARBON STEEL WELDING WIRE

- Highest combination of manganese and silicone deoxidizers
- Permits high current welding with CO₂ gas shielding
- Can also be applied with ArCO₂
- Excellent wetting
- Good for out-of-position welding using short circuiting transfer
- Layer/level wound wire
- Certified by CWB to CSA class W48 for ER49S-6
- Certified by AWS to class A5.18 for ER70S6



NT549



TTU049



Priced per Spool

Model No.	Diameter	Spool Wt.	Spools Per Master Box	Price /Each
NT549	0.023"/0.6 mm	2 lbs./0.9 kg	18	6.50
NT550	0.030"/0.8 mm	2 lbs./0.9 kg	18	4.55
NT551	0.035"/0.9 mm	2 lbs./0.9 kg	18	4.40
NT552	0.045"/1.14 mm	2 lbs./0.9 kg	18	4.20
NT553	0.023"/0.6 mm	11 lbs./5 kg	4	28.95
NT554	0.030"/0.8 mm	11 lbs./5 kg	4	18.25
NT555	0.035"/0.9 mm	11 lbs./5 kg	4	17.75
NT556	0.023"/0.6 mm	33 lbs./15 kg	1	77.25
NT557	0.030"/0.8 mm	33 lbs./15 kg	1	48.50
NT560	0.035"/0.9 mm	44 lbs./20 kg	1	61.85
NT561	0.045"/1.14 mm	44 lbs./20 kg	1	57.95

Priced per Drum

Model No.	Diameter	Drum Weight	Qty Per Pallet	Price /Each
TTU049	0.035"/0.9 mm	550 lbs./250 kg	4	797.00
TTU519	0.045"/1.14 mm	550 lbs./250 kg	4	738.00

SELF-SHIELDING MILD STEEL FLUX-CORED WELDING WIRE

- Self-shielding—Welds steel without gas
- Gasless steel welding wire for single pass applications
- Excellent for use on thin gauges of galvanized and mild steels

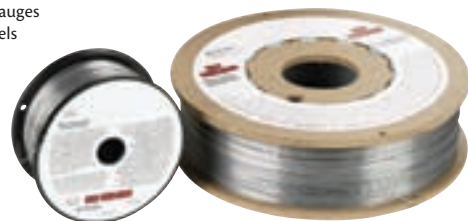

Priced per Spool

Model No.	Mfg. No.	Dia."	Wt. lbs.	Price /Each
TTU700	E71TGS030X2SP	0.030	2	19.60
TTU701	E71TGS035X2SP	0.035	2	18.70
TTU702	E71TGS030X10SP	0.030	10	82.80
TTU703	E71TGS035X10SP	0.035	10	77.50
TTU704	E71TGS030X25SP	0.030	25	217.00
TTU705	E71TGS035X25SP	0.035	25	212.00
TTU706	E71TGS045X25SP	0.045	25	209.00

MIG WIRE CLEANING PADS

- Designed for use on all MIG wire feeders
- Removes dust and dirt from the wire prior to wire entry into the liner conduit
- Use of wire feed pads can decrease the coefficient of friction in the liner as much as 50%-60% and reduce erratic feed and burn backs
- Treated pads can be used on all alloyed wires except aluminum

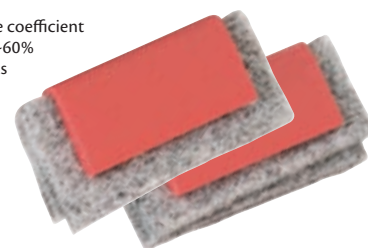

Priced per Package

Model No.	Qty/Pkg.	Price/Each
720-1000-KIT	6	9.31
720-1010-KIT	24	37.20

See pages 1094 - 1098 for
MIG Guns and Accessories



MILD STEEL STICK ELECTRODES

• Priced per 5-lb. tube

6010

- High cellulose coated electrode designed to provide a smooth stable arc forceful enough to achieve deep penetration into the base metal
- Produce a flat weld bead with coarse ripples and a thin easily removable slag
- May be used in the flat, horizontal, vertical or overhead welding positions

6011

- A versatile, deep penetrating, all-position electrode for steel
- Offer excellent mechanical properties in the welding of mild steels, galvanized and some low alloy steels
- Operate on AC or DCEP

6013

- A general purpose, all-position electrodes for mild steel
- Establishes a smooth, quiet, medium penetrating arc that is readily maintained with minimal spatter loss
- Slag lifts easily, revealing a finely rippled bead contour
- Ideally suited for general purpose welding, even with small AC power sources having low open-circuit voltage
- Operates on AC, DCEN or DCEP

7014

- An all position electrode for mild and low alloy steels
- Iron powder covering content yields a high deposition rate in all positions
- Particularly advantageous when poor fit-up exists
- Operates on AC, DCEN or DCEP

7018

- A high deposition electrode for low and medium carbon steels
- An efficient, all-position, iron powder, low hydrogen type electrode
- Exhibits excellent mechanical properties, crack resistant, and X-ray quality welds
- Operates on AC or DCEP



Priced per Tube

Model No.	Mfg. No.	Dia."	Wt. lbs.	Price /Each
6010				
TTU707	6010332E5	3/32	5	25.00
TTU708	601018E5	1/8	5	24.20
TTU709	6010532E5	5/32	5	24.20
6011				
TTU710	6011332E5	3/32	5	23.40
TTU711	601118E5	1/8	5	22.80
TTU712	6011532E5	5/32	5	22.60
6013				
TTU713	6013332E5	3/32	5	17.50
TTU714	601318E5	1/8	5	17.20
TTU715	6013532E5	5/32	5	17.00
7014				
TTU716	7014332E5	3/32	5	20.90
TTU717	701418E5	1/8	5	20.50
TTU718	7014532E5	5/32	5	20.30
7018				
TTU719	7018332E5	3/32	5	20.20
TTU720	701818E5	1/8	5	19.50
TTU721	7018532E5	5/32	5	19.30

36" MILD STEEL CUT LENGTH TIG RODS

• Priced per 10-lb. tube

ER70S-2

This premium quality TIG rod gives welds of the highest quality, even on rust or dirty surfaces due to the deoxidising agents in the wire.

- Can also be used for pipe, plate, and sheet applications where structural integrity is a primary consideration
- AWS A5.18-79

R45

General purpose mild steel rod for TIG or gas welding.

- A general purpose rod used for welding low-carbon sheet, plate and pipe
- Widely used for automotive repair work and is ideal for ornamental art purposes
- AWS A5.2-80

R60

Recommended for gas or TIG welding plate, sheet, pipe, castings, or structural shapes.

- Produces welds of a higher tensile strength than R45
- AWS A5.2-80

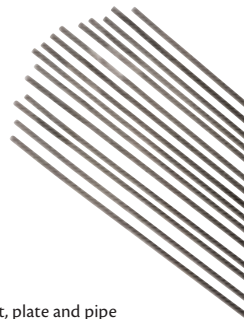

Priced per Tube

Model No.	Mfg. No.	Dia."	Wt. lbs	Price /Each
ER70S-2				
TTU722	E70S2035X36T	0.035	10	69.50
TTU723	E70S2045X36T	0.045	10	62.80
TTU724	E70S2116X36T	1/16	10	61.50
TTU725	E70S2332X36T	3/32	10	59.70
TTU726	E70S218X36T	1/8	10	59.30
TTU727	E70S2532X36T	5/32	10	58.90
R45				
TTU728	R45116X36T	1/16	10	36.00
TTU729	R45332X36T	3/32	10	35.00
TTU730	R4518X36T	1/8	10	34.30
TTU731	R45532X36T	5/32	10	34.10
TTU732	R45316X36T	3/16	10	34.10
R60				
TTU733	R60116X36T	1/16	10	46.40
TTU734	R60332X36T	3/32	10	45.00
TTU735	R6018X36T	1/8	10	44.30
TTU736	R60532X36T	5/32	10	44.10
TTU737	R60316X36T	3/16	10	44.10

MILD STEEL STICK ELECTRODES – CWB APPROVED

FLEETWELD® 35 - E6011

- Fill freeze, out-of-position mild steel stick electrodes
- A proven performer for sheet metal welding applications and AC pipe welding
- A great electrode to use on jobs where the steel isn't clean
- AC DC +/-



Priced per Tube

Model No.	Mfg. No.	Diameter"	Wt. kg	Price/Each
TTU006	EDS11006	3/32	4 (8.8 lbs.)	41.20
TTU007	EDS11007	1/8	5 (11 lbs.)	42.50
TTU008	EDS11008	5/32	5 (11 lbs.)	41.50

FLEETWELD® 37 - E6013

- Fill freeze, high speed, mild stick electrodes
- An all-position electrode for low amperage welding on sheet metal, especially in applications where appearance is important
- Ideal for jobs involving irregular or short welds that require a change in positions
- AC DC +/-



TTU010

Priced per Tube

Model No.	Mfg. No.	Diameter"	Wt. kg	Price/Each
TTU009	EDS11213	3/32	4 (8.8 lbs.)	42.10
TTU010	EDS11011	1/8	5 (11 lbs.)	42.60
TTU011	EDS11012	5/32	5 (11 lbs.)	40.60

FLEETWELD® 47 - E7014

- Fill freeze, high speed, and mild stick electrodes
- Features high deposition rates for fast performance
- Ideal for sheet metal lap joints and fillet welds, general purpose plate welding and maintenance jobs
- AC DC +/-

Priced per Tube

Model No.	Mfg. No.	Diameter"	Wt. kg	Price/Each
TTU012	EDS11016	3/32	4 (8.8 lbs.)	42.00
TTU013	EDS11017	1/8	5 (11 lbs.)	42.60
TTU014	EDS11018	5/32	5 (11 lbs.)	40.20

JETWELD® LH-70 - E7018

- Low hydrogen, mild steel stick electrodes
- Ideal for welding on thick sections and restraining joints when cracking is an issue, as well as hard-to-weld steels
- DC+ AC

Priced per Tube

Model No.	Mfg. No.	Diameter"	Wt. kg	Price/Each
TTU015	EDS11041	3/32	4 (8.8 lbs.)	38.80
TTU016	EDS11042	1/8	5 (11 lbs.)	40.10
TTU017	EDS11043	5/32	5 (11 lbs.)	38.90

ER308L, ER309L & ER316L STAINLESS STEEL WELDING WIRE



- Stainless steel spooled wires and cut lengths are precisely produced to conform to the requirements of AWS A5.9
- Manufactured to exacting standards with particular attention given to cleanliness, concentricity and helix of the finished product



Priced per Spool

Model No.	Mfg. No.	Dia."	Wt. lbs.	Price/Each
ER308L SPOOLED WIRE				
TTU760	308L025X2SP	0.025	2	32.40
TTU751	308L025X10SP	0.025	10	147.00
TTU738	308L025X25SP	0.025	25	289.00
TTU761	308L030X2SP	0.030	2	29.20
TTU752	308L030X10SP	0.030	10	133.00
TTU739	308L030X25SP	0.030	25	270.00
TTU762	308L035X2SP	0.035	2	27.30
TTU753	308L035X10SP	0.035	10	126.00
TTU740	308L035X25SP	0.035	25	263.00
TTU741	308L045X25SP	0.045	25	258.00
TTU742	308L116X25SP	1/16	25	255.00
ER309L SPOOLED WIRE				
TTU754	309L025X10SP	0.025	10	175.00
TTU763	309L030X2SP	0.030	2	34.50
TTU755	309L030X10SP	0.030	10	161.00
TTU743	309L030X25SP	0.030	25	335.00
TTU764	309L035X2SP	0.035	2	32.70
TTU756	309L035X10SP	0.035	10	153.00
TTU744	309L035X25SP	0.035	25	327.00
TTU745	309L045X25SP	0.045	25	320.00
TTU746	309L116X25SP	1/16	25	318.00
ER316L SPOOLED WIRE				
TTU765	316L025X2SP	0.025	2	38.60
TTU757	316L025X10SP	0.025	10	179.00
TTU766	316L030X2SP	0.030	2	35.10
TTU758	316L030X10SP	0.030	10	164.00
TTU747	316L030X25SP	0.030	25	341.00
TTU767	316L035X2SP	0.035	2	33.30
TTU759	316L035X10SP	0.035	10	155.00
TTU748	316L035X25SP	0.035	25	334.00
TTU749	316L045X25SP	0.045	25	328.00
TTU750	316L116X25SP	1/16	25	324.00

36" STAINLESS STEEL CUT LENGTH TIG RODS

- **308L** - For joining 304 and 304L and other 18-8 stainless steels
- **309L** - For 309 stainless steels and joining carbon steels or low alloy steels to stainless steels
- **316L** - For joining 316L stainless steels
- Priced per 10-lb. tube



Priced per Tube

Model No.	Mfg. No.	Dia."	Wt. lbs.	Price/Each
308L				
TTU768	308L030X36T	0.030	10	141.00
TTU769	308L035X36T	0.035	10	134.00
TTU770	308L045X36T	0.045	10	126.00
TTU771	308L116X36T	1/16	10	103.00
TTU772	308L332X36T	3/32	10	96.50
TTU773	308L18X36T	1/8	10	93.80
TTU774	308L532X36T	5/32	10	93.80
TTU775	308L316X36T	3/16	10	93.80
309L				
TTU776	309L035X36T	0.035	10	160.00
TTU777	309L045X36T	0.045	10	151.00
TTU778	309L116X36T	1/16	10	128.00
TTU779	309L332X36T	3/32	10	122.00
TTU780	309L18X36T	1/8	10	119.00
TTU781	309L532X36T	5/32	10	119.00
316L				
TTU782	316L030X36T	0.030	10	168.00
TTU783	316L035X36T	0.035	10	162.00
TTU784	316L045X36T	0.045	10	153.00
TTU785	316L116X36T	1/16	10	130.00
TTU786	316L332X36T	3/32	10	124.00
TTU787	316L18X36T	1/8	10	121.00
TTU788	316L532X36T	5/32	10	121.00
TTU789	316L316X36T	3/16	10	121.00

STAINLESS STEEL GAS SHIELD FLUX-CORED WIRE



Precisely formulated for all-position versatility with a smooth arc, good wetting and overall operator appeal. Products conform to AWS Specification A5.22.

308LT1-1

Most frequently used for base metals of similar composition such as AISI Types 301, 302, 304, 305 and 308.

309LT1-1

Used for welding similar alloys in wrought or cast form; occasionally, to weld Type 304 base metals when severe corrosion conditions exist; and, at times, welding dissimilar steels.

316LT1-1

Used for welding similar alloys (containing about 2% molybdenum); also for high temperature service applications (the presence of molybdenum provides increased creep resistance at elevated temperatures).



TTU790



TTU793



TTU796

Priced per Spool

Model No.	Mfg. No.	Dia."	Wt. lbs.	Price /Each
308LT1-1				
TTU790	308LT11035X25SP	0.035	25	692.00
TTU791	308LT11045X25SP	0.045	25	512.00
TTU792	308LT11116X25SP	1/16	25	494.00
309LT1-1				
TTU793	309LT11035X25SP	0.035	25	721.00
TTU794	309LT11045X25SP	0.045	25	561.00
TTU795	309LT11116X25SP	1/16	25	537.00
316LT1-1				
TTU796	316LT11035X25SP	0.035	25	736.00
TTU797	316LT11045X25SP	0.045	25	566.00
TTU798	316LT11116X25SP	1/16	25	542.00

STAINLESS STEEL ELECTRODES



- Exactly manufactured to conform to the requirements of AWS5.4
- Priced per 5 or 10-lb. tube



Priced per Tube

Model No.	Mfg. No.	Dia." x Length"	Wt. lbs.	Price /Each
308L-16				
TTU799	308L16116E	1/16 x 10	5	87.00
TTU800	308L16332E	3/32 x 12	10	110.00
TTU801	308L1618E	1/8 x 14	10	108.00
TTU802	308L16532E	5/32 x 14	10	108.00
TTU803	308L16316E	3/16 x 14	10	108.00
309L-16				
TTU804	309L16332E	3/32 x 12	10	133.00
TTU805	309L1618E	1/8 x 14	10	131.00
TTU806	309L16532E	5/32 x 14	10	131.00
TTU807	309L16316E	3/16 x 14	10	131.00
316L-16				
TTU808	316L16332E	3/32 x 12	10	134.00
TTU809	316L1618E	1/8 x 14	10	132.00
TTU810	316L16532E	5/32 x 14	10	132.00
TTU811	316L16316E	3/16 x 14	10	132.00

ALLOYS

DEOXIDIZED COPPER WELDING WIRE

- Recommended for welding applications where joints of high copper content are involved
- Deoxidized copper contains phosphorus and silicon as de-oxidizing agents which promote sound weld joints
- Produces trouble-free welds that are a good colour match to copper and have good electrical conductivity
- Can be used with inert gas arc and oxyacetylene welding
- Each container has an identification label showing grade, size, weight and heat number
- AWS A5.7, ErCu



Priced per Spool

Model No.	Mfg. No.	Dia."	Wt. lbs.	Price/Each
TTU812	DOC035X30SP	0.035	30	609.00
TTU813	DOC045X30SP	0.045	30	605.00
TTU814	DOC116X30SP	1/16	30	603.00
TTU815	DOC332X30SP	3/32	30	603.00

36" CUT LENGTH				
Priced per Tube				
TTU827	DOC116X36T	1/16	10	199.00
TTU828	DOC332X36T	3/32	10	198.00
TTU829	DOC18X36T	1/8	10	198.00
TTU830	DOC316X36T	3/16	10	198.00

SILICON BRONZE WELDING WIRE

- Used for inert gas arc welding of copper, copper-silicone, and copper-based metals to themselves as well as to steel
- Frequently used to gas tungsten arc and gas metal arc weld coated steels
- Also used to surface areas subject to corrosion
- Each container has an identification label showing grade, size, weight and heat number
- AWS A5.27, ERCuSi-A
- Conformance certifications can be furnished upon request



Priced per Spool

Model No.	Mfg. No.	Dia."	Wt. lbs.	Price/Each
TTU824	SIB030X2SP	0.030	2	43.80
TTU825	SIB035X2SP	0.035	2	43.40
TTU826	SIB045X2SP	0.045	2	43.40
TTU820	SIB025X10SP	0.025	10	224.00
TTU821	SIB030X10SP	0.030	10	215.00
TTU822	SIB035X10SP	0.035	10	213.00
TTU823	SIB045X10SP	0.045	10	210.00
TTU816	SIB030X30SP	0.030	30	627.00
TTU817	SIB035X30SP	0.035	30	617.00
TTU818	SIB045X30SP	0.045	30	609.00
TTU819	SIB116X30SP	1/16	30	605.00

36" CUT LENGTH				
Priced per Tube				
TTU831	SIB035X36T	0.035	10	226.00
TTU832	SIB045X36T	0.045	10	222.00
TTU833	SIB116X36T	1/16	10	203.00
TTU834	SIB332X36T	3/32	10	199.00
TTU835	SIB18X36T	1/8	10	199.00
TTU836	SIB532X36T	5/32	10	199.00
TTU837	SIB316X36T	3/16	10	199.00
TTU838	SIB14X36T	1/4	10	199.00

36" BARE NICKEL SILVER CUT LENGTH TIG RODS

- Recommended for applications requiring higher mechanical properties and situations where good colour match is important
- Primarily intended for braze welding steel and cast iron
- Melting point of 1680°F (916°C)
- RBCuZn-D
- Priced per 10-lb. tube



Priced per Tube

Model No.	Mfg. No.	Dia."	Wt. lbs.	Price/Each
TTU851	NS116X36T	1/16	10	209.00
TTU852	NS332X36T	3/32	10	192.00
TTU853	NS18X36T	1/8	10	189.00
TTU854	NS316X36T	3/16	10	187.00
TTU855	NS14X36T	1/4	10	187.00

36" LOW FUMING BRONZE CUT LENGTH TIG RODS



- Fuming qualities and good mechanical properties makes it a widely used general purpose rod
- Provides higher mechanical properties than obtainable with naval bronze
- Used extensively for braze welding steel and cast iron
- Melting point of 1620°F (882°C)
- RBCuZn-C
- Priced per 10-lb. tube



Priced per Tube

Model No.	Mfg. No.	Dia."	Wt. lbs.	Price/Each
BARE				
TTU839	LFB116X36T	1/16	10	150.00
TTU840	LFB332X36T	3/32	10	148.00
TTU841	LFB18X36T	1/8	10	146.00
TTU842	LFB532X36T	5/32	10	144.00
TTU843	LFB316X36T	3/16	10	144.00
TTU844	LFB14X36T	1/4	10	144.00
TTU845	LFB516X36T	5/16	10	144.00
TTU846	LFB38X36T	3/8	10	144.00
FLUX-COATED				
TTU847	LFBFC332X36T	3/32	10	148.00
TTU848	LFBFC18X36T	1/8	10	146.00
TTU849	LFBFC532X36T	5/32	10	145.00
TTU850	LFBFC316X36T	3/16	10	145.00

4043 & 5356 ALUMINUM WELDING WIRE

- Cleanliness, density and temper of wires are precisely controlled
- Each container has an identification label showing grade, size, weight and heat number
- Conform to AWS A5.10 classification, CWB and ABS approvals



4043

- 5% silicon all position aluminum weld wire used to weld heat treatable alloys such as the 6XXX base metals and cast alloys
- Found in many common welding applications such as bicycles, trucks, trailers and automotive parts and equipment
- Silicon with these alloys give improved wetting action yielding a less crack sensitive bright weld bead



5356

- 5% magnesium all position non-heat treatable wire used to weld the 5XXX series alloys
- Common welding applications such as boats, ships, bicycles, trucks, pressure vessels and automotive parts and equipment

Priced per Spool

Model No.	Mfg. No.	Dia."	Wt. lbs.	Price/Each
4043				
TTU956	40430301SP	0.030	1	9.92
TTU957	40430351SP	0.035	1	9.13
TTU958	40433641SP	3/64	1	8.71
TTU959	40430305SP	0.030	5	49.60
TTU960	40430355SP	0.035	5	45.60
TTU961	404303016SP	0.030	16	147.00
TTU962	404303516SP	0.035	16	133.00
TTU963	404336416SP	3/64	16	124.00
TTU964	404311616SP	1/16	16	122.00

5356

TTU965	53560301SP	0.030	1	10.10
TTU966	53560351SP	0.035	1	9.27
TTU967	53563641SP	3/64	1	8.85
TTU968	53560305SP	0.030	5	50.30
TTU969	53560355SP	0.035	5	46.30
TTV020	53563645SP	3/64	5	44.30
TTU970	535603016SP	0.030	16	149.00
TTU971	535603516SP	0.035	16	135.00
TTU972	535636416SP	3/64	16	126.00
TTU973	535611616SP	1/16	16	124.00

36" CUT LENGTH

Priced per Package

4043				
TTU974	404311636T	1/16	10	79.80
TTU975	404333236T	3/32	10	73.40
TTU976	40431836T	1/8	10	72.10
TTU977	404353236T	5/32	10	72.10
TTU978	404331636T	3/16	10	72.10

5356				
TTU979	535611636T	1/16	10	81.30
TTU980	535633236T	3/32	10	74.60
TTU981	53561836T	1/8	10	72.60
TTU982	535653236T	5/32	10	72.60
TTU983	535631636T	3/16	10	72.60

ALUMINUM 340 ELECTRODES (DC-REVERSE)

- Features a precise combination of core wire and coating, providing high speed deposition of dense, machineable welds
- Tensile strength – up to 34 000 PSI
- Good colour match and corrosion resistance
- **Priced per 5-lb. tube (5 - 1-lb. bags)**



Applications:

Recommended for fabrication and repair of cast and wrought aluminum. Excellent for foundry defects, machining errors and all types of salvage work. Widely used on sheets, tubes and extrusions in thicknesses of 1/8" or more. Also well-suited to torch applications.

Priced per Tube

Model No.	Mfg. No.	Dimensions	Wt. lbs.	Price /Each
		Dia." x Length"		
TTU856	ALSMOOTH340332E	3/32 x 14	5	150.00
TTU857	ALSMOOTH34018E	1/8 x 14	5	137.00
TTU858	ALSMOOTH340532E	5/32 x 14	5	137.00

NICKEL 55 ELECTRODES

- A general purpose, nickel-iron electrode for production, salvage and repair of all cast irons (AWS A15.15, ENiFeCl)
- Tensile strength – up to 70 000 PSI
- Suited to joining, filling and buildup of grey and alloyed cast irons
- **Priced per 10-lb. tube**

Applications: Can be used for fabrication and repair of pump housings, valves, castings, cast and malleable fittings, and for general repair of all cast irons. Deposits are machineable and have high strength.



Priced per Tube

Model No.	Mfg. No.	Dia."	Wt. lbs.	Price /Each
TTU862	NI55332E	3/32	10	282.00
TTU863	NI5518E	1/8	10	282.00
TTU864	NI5532E	5/32	10	282.00
TTU865	NI55316E	3/16	10	282.00

HIGH SILVER BRAZING ALLOYS

Weldcote 45CF - General purpose silver brazing alloy with a wide melting range and widely used in many brazing operations. Commonly used to join any combinations of copper, brass, steel and bronze. Colour is yellow white to light gold.

Chemical Composition (Wt. percent):

Silver	44.0 – 46.0
Copper	29.0 – 31.0
Zinc	23.0 – 27.0
Other Elements	0.15

Weldcote 56CF - Cadmium free silver brazing alloy with a narrow melting range and the lowest working temperature in the cad-free family yielding premium flow, wetting, ductility, penetration. Commonly used to join any combinations of copper, brass, steel, bronze and stainless steel. Great choice for food handling equipment and color match on stainless and nickel alloys while minimizing stress corrosion cracking. Colour is white to light gold.

Chemical Composition (Wt. percent):

Silver	55.0 – 57.0
Copper	21.0 – 23.0
Zinc	15.0 – 19.0
Tin	4.5 – 5.5
Other Elements	0.15



WELDCOTE 45CF

Model No.	Mfg. No.	Description	Specifications	Solidus	Liquidus	Brazing Range	Price /Each
TTU870	45CF132X1T0C	1/32" x 1 T.O.	AWS A5.8	1225°F	1370°F	1370-1550°F	P.O.A.
TTU871	45CF132X5T0C	1/32" x 5 T.O.	Bag-5	663°C	743°C	743-843°C	P.O.A.
TTU872	45CF364X1T0C	3/64" x 1 T.O.					P.O.A.
TTU873	45CF116X1T0C	1/16" x 1 T.O.					P.O.A.
TTU874	45CF116X5T0C	1/16" x 5 T.O.					P.O.A.
TTU875	45CF332X1T0C	3/32" x 1 T.O.					P.O.A.
TTU876	45CF332X5T0C	3/32" x 5 T.O.					P.O.A.
TTU877	45FCF116X18L4	Flux-Coated 1/16" x 18" x 4 oz. Tube					P.O.A.
TTU878	45FCF332X18L4	Flux-Coated 3/32" x 18" x 4 oz. Tube					P.O.A.

SUPER 120 ELECTRODES

- Ultimate electrodes for welding steel with highest strength and maximum ductility (AC-DC)
- Assures dense, non-cracking welds on problem steels such as: high carbon, tool, spring, manganese, and dissimilar steels
- Tensile strength – up to 120 000 PSI
- Yield strength – up to 85 000 PSI
- Ductility – up to 35% elongation in 2"
- **Priced per 5 or 10-lb. tube**

Applications: Particularly advantageous when the alloy content of the steel to be welded is unknown.



Priced per Tube

Model No.	Mfg. No.	Dia."	Wt. lbs.	Price /Each
TTU859	SUPER120332E	3/32	5	154.00
TTU860	SUPER12018E	1/8	10	267.00
TTU861	SUPER120532E	5/32	10	267.00

NICKEL 99 ELECTRODES

- A general purpose, high nickel electrode for production and repair of cast iron (AWS A5.15, ENiCl)
- Tensile strength – up to 50 000 PSI
- **Priced per 10-lb. tube**

Applications: Ideal for building up, joining, filling holes, breaks and cracks in all types of cast iron. It has very-good out-of-position welding characteristics. Parts are frequently repaired without dismantling.



Priced per Tube

Model No.	Mfg. No.	Dia."	Wt. lbs.	Price /Each
TTU866	NI99332E	3/32	10	384.00
TTU867	NI9918E	1/8	10	384.00
TTU868	NI9932E	5/32	10	384.00
TTU869	NI99316E	3/16	10	384.00



TTU878

WELDCOTE 56CF

Model No.	Mfg. No.	Description	Specifications	Solidus	Liquidus	Brazing Range	Price /Each
TTU879	56CF132X1T0C	1/32" x 1 T.O.	AWS A5.8	1145°F	1205°F	1205-14006°F	P.O.A.
TTU880	56CF132X5T0C	1/32" x 5 T.O.	Bag-7	618°C	652°C	652-760°C	P.O.A.
TTU881	56CF364X1T0C	3/64" x 1 T.O.					P.O.A.
TTU882	56CF116X1T0C	1/16" x 1 T.O.					P.O.A.
TTU883	56CF116X5T0C	1/16" x 5 T.O.					P.O.A.
TTU884	56CF332X1T0C	3/32" x 1 T.O.					P.O.A.
TTU885	56CF332X5T0C	3/32" x 5 T.O.					P.O.A.
TTU886	56FCF116X18L4	Flux-Coated 1/16" x 18" x 4 oz. Tube					P.O.A.
TTU887	56FCF332X18L4	Flux-Coated 3/32" x 18" x 4 oz. Tube					P.O.A.

ALLOYS

COMMON WIRE SOLDERS

- With some exceptions, the tin/lead solders can be used to solder copper and most copper alloys, lead, nickel alloys and steel
- Heat sources include soldering guns, irons and torch applications
- **Acid Core:** For soldering materials with poor solderability, stainless steel application
- **Rosin Core:** For electrical application
- **Tin/Antimony 95/5:** Useful for applications where moderately elevated temperatures is a factor. It has a high electrical conductivity and high fluidity, recommended where lead contamination must be avoided; not recommended for use on brass or HVAC connections

CAUTION: Lead-bearing solders are not to be used in potable water systems

Priced per Spool

Model No.	Mfg. No.	Description	Specifications	Solidus	Liquidus	Price /Each
40% TIN/60% LEAD SOLID						
TTU888	4060116X1SP	1/16" x 1# Spool	ASTM-B32, Sn-40A	362°F	460°F	39.30
TTU889	4060332X1SP	3/32" x 1# Spool		183°C	238°C	37.10
TTU890	406018X1SP	1/8" x 1# Spool				35.70
50% TIN/50% LEAD SOLID						
TTU891	5050116X1SP	1/16" x 1# Spool	ASTM-B32, Sn-50	362°F	420°F	45.80
TTU892	5050332X1SP	3/32" x 1# Spool		183°C	215°C	43.20
TTU893	505018X1SP	1/8" x 1# Spool				41.80
50% TIN/50% LEAD ACID CORE						
TTU894	5050AC116X1SP	1/16" x 1# Spool	ASTM-B32, Sn-50	362°F	420°F	46.10
TTU895	5050AC332X1SP	3/32" x 1# Spool		183°C	215°C	43.90
TTU896	5050AC18X1SP	1/8" x 1# Spool				41.80
TTU897	5050AC18X5SP	1/8" x 5# Spool				208.00



TTU891

weldcote
metals

Priced per Spool

Model No.	Mfg. No.	Description	Specifications	Solidus	Liquidus	Price /Each
50% TIN/50% LEAD ROSIN CORE						
TTU898	5050RC116X1SP	1/16" x 1# Spool	ASTM-B32, Sn-50	362°F	420°F	46.10
TTU899	5050RC332X1SP	3/32" x 1# Spool		183°C	215°C	43.90
TTU900	5050RC18X1SP	1/8" x 1# Spool				41.80
TTU901	5050RC18X5SP	1/8" x 5# Spool				208.00
95% TIN/5% ANTIMONY SOLID						
TTU902	955116X1SP	1/16" x 1# Spool	ASTM-B32, Sb-5	450°F	464°F	75.30
TTU903	955332X1SP	3/32" x 1# Spool		232°C	240°C	73.00
TTU904	95518X1SP	1/8" x 1# Spool				71.00

36" CUT LENGTH TIG RODS – POINT OF PURCHASE PACKAGED ALLOYS

- Convenient small package is ideal for maintenance and repair job
- MSDS are packaged in each tube
- 1-lb. tube



TTU932

weldcote
metals

Priced per Tube

Model No.	Mfg. No.	Diameter"	Wt. lbs.	Price /Each
308L – STAINLESS STEEL				
TTU921	308L116X36T1P	1/16	1	15.20
TTU922	308L332X36T1P	3/32	1	14.60
TTU923	308L18X36T1P	1/8	1	14.40
309L – STAINLESS STEEL				
TTU924	309L116X36T1P	1/16	1	17.70
TTU925	309L332X36T1P	3/32	1	17.10
TTU926	309L18X36T1P	1/8	1	16.90
316L – STAINLESS STEEL				
TTU927	316L116X36T1P	1/16	1	18.00
TTU928	316L332X36T1P	3/32	1	17.30
TTU929	316L18X36T1P	1/8	1	17.10
4043 – ALUMINUM				
TTU930	4043116X36T1P	1/16	1	15.60
TTU931	4043332X36T1P	3/32	1	14.80
TTU932	404318X36T1P	1/8	1	14.60
5356 – ALUMINUM				
TTU933	5356116X36T1P	1/16	1	15.80
TTU934	5356332X36T1P	3/32	1	14.90
TTU935	535618X36T1P	1/8	1	14.80
ER70S-2 – TRIPLE DEOXIDIZED STEEL				
TTU936	ER70S2116X36T1P	1/16	1	11.10
TTU937	ER70S2332X36T1P	3/32	1	10.90
TTU938	ER70S218X36T1P	1/8	1	10.90



TTU922



TTU938



TTU949

Priced per Tube

Model No.	Mfg. No.	Diameter"	Wt. lbs.	Price /Each
LOW FUMING BRONZE - BARE				
TTU942	LF8116X36T1P	1/16	1	19.90
TTU943	LF8332X36T1P	3/32	1	19.70
TTU944	LF818X36T1P	1/8	1	19.50
LOW FUMING BRONZE – FLUX-COATED				
TTU945	LF8FC332X36T1P	3/32	1	19.70
TTU946	LF8FC18X36T1P	1/8	1	19.50
R45 – MILD STEEL				
TTU947	R45116X36T1P	1/16	1	8.57
TTU948	R45332X36T1P	3/32	1	8.47
TTU949	R4518X36T1P	1/8	1	8.41
R60 – HIGH TENSILE MILD STEEL				
TTU950	R60116X36T1P	1/16	1	9.62
TTU951	R60332X36T1P	3/32	1	9.46
TTU952	R6018X36T1P	1/8	1	9.41
S18 – SILICON BRONZE				
TTU953	S18116X36T1P	1/16	1	25.30
TTU954	S18332X36T1P	3/32	1	25.10
TTU955	S1818X36T1P	1/8	1	25.10

WHITE PASTE BRAZING FLUX

- For use with silver brazing alloys on all metal other than aluminum, magnesium or titanium
- Effective to 1600°F
- Meets AMS 3410, AWS A5.31-92, Type FB3A, Fed Spec. 0-F-499, Type B



Model No.	Mfg. No.	Size	Price /Each
TTU906	WPFLUX14JAR	1/4 lb.	9.03
TTU907	WPFLUX12JAR	1/2 lb.	11.30
TTU908	WPFLUX1JAR	1 lb.	13.50
TTU909*	WPFLUX6OZ	6 oz.	10.70
TTU910	WPFLUX5JAR	5 lb.	60.50

*Comes with brush cap



TTU908

GENERAL PURPOSE LIQUID SOLDERING FLUX

- Water-based, inorganic-acid flux formulated for virtually all metals other than aluminum, magnesium or titanium
- Contains Zinc Chloride, Ammonium Chloride, and Hydrochloric Acid, makes this flux active at room temperature where it begins to clean metals and remove oxides
- Pre-cleaning is not necessary under most conditions



Model No.	Mfg. No.	Size	Price /Each
TTU915	LIQUIDFLUX4OZ	4 oz.	9.46
TTU916	LIQUIDFLUX16OZ	16 oz.	18.20
TTU917	LIQUIDFLUX1GL	1 Gallon	73.40



TTU915

BLACK PASTE BRAZING FLUX

- Use with silver or other brazing alloys liquidus below 1800°F
- Recommended for stainless, heavy parts and whenever heating cycle is prolonged
- For all metals other than aluminum, magnesium or titanium
- Meets AMS 3411, AWS 5.31, Class FB3C; Fed. Spec. 0-F-499D, Type B



Model No.	Mfg. No.	Size	Price /Each
TTU911	BPFLUX12JAR	1/2 lb.	14.60
TTU912	BPFLUX1JAR	1 lb.	17.60
TTU913	BPFLUX5JAR	5 lb.	82.20



TTU911

GENERAL PURPOSE PASTE SOLDERING FLUX

- Excellent flux for joining copper to copper, and copper to brass
- Not recommended for electrical or electronic applications
- Effective to 700°F
- Meets Fed. Spec. 0-F 506C, Type 1, Form A and MIL-S-6872A



Model No.	Mfg. No.	Size	Price /Each
TTU918	PASTEFLUX4OZ	4 oz.	8.94
TTU919	PASTEFLUX16OZ	16 oz.	13.10



TTU919

WHITE ANTIBORAX FLUX

- General purpose brazing flux
- Use with low fuming bronze and nickel bronze brazing alloys
- Highly active powder flux has applications in brazing steel, cast irons and copper-base alloys
- Active in a heat range between 1400° and 2200°F
- Meets MIL-F-16136B, Types A and B, AWS 5.31-91, Type FB3J



Model No.	Mfg. No.	Size	Price /Each
TTU914	WPWDFLUX1JAR	1 lb.	14.40



TTU914

CAST IRON FLUX

- A powder flux for welding cast iron
- Use with any commercial cast iron torch welding alloy
- Specially prepared to produce better results on "problem" cast iron
- Wide active heat range of 1400° to 2200°F eliminates the necessity of several different fluxes



Model No.	Mfg. No.	Size	Price /Each
TTU920	CASTIRONFLUX1JR	1 lb.	22.70



TTU920

ACID/FLUX BRUSHES

- Perfect brushes for applying liquid or paste flux



Model No.	Mfg. No.	Width"	Trim Length"	Overall Length"	Price /Each
BY189	74059	1/4	11/16	6	0.19
BY190	74060	3/8	7/8	6 1/8	0.19
BY191	74061	7/16	7/8	6 1/8	0.19
BY192	74062	9/16	7/8	6 1/8	0.24

AL-BRAZE E.C. ALUMINUM BRAZING FLUX

- Powdered flux is recommended to use with 4047 (formerly 718) brazing alloy, and other aluminum brazing alloys
- May be mixed with water or alcohol to form a paste
- Meets specs AMS 3412, AWS A5.31 Type FB1A



Model No.	Mfg. No.	Size	Price /Each
841-1137	ECDF1/2	8 oz.	14.10



METAL WORKING MARKERS

VALVE ACTION® PAINT MARKERS



- Fast drying, lead-free paint marker, ideal for all surfaces
- Weather and fade resistant
- Replaceable fibre tip ensures full use of the marker
- Marking range -50° to 150°F
- Also available in fluorescent colours



Priced per Marker

Model No.	Colour	Price /Each
PA418	White	4.39
PA419	Yellow	4.39
PA420	Red	4.39
PA421	Blue	4.39
PA422	Green	4.39
PA431	Black	4.39
PA424	Replacement Tips (Pkg. of 12)	8.91

PRO-LINE® FINE LINE MARKERS



- High strength, lightweight barrel for industrial use
- Ideal for metal, suitable for wood, glass, plastic and rubber
- Xylene-free
- Self-storing cap with integrated pocket clip
- Ergonomic design for comfortable extended use



Priced per Marker

Model No.	Colour	Price /Each
PC461	White	4.88
PC462	Yellow	4.88
PC463	Black	4.88

THERMOMELT® HEAT STIK TEMPERATURE INDICATORS

ACCURATE SURFACE TEMPERATURE MEASUREMENT STICKS

- Industry's longest lasting 5" stick
- 33% bigger and stronger than competitive brands
- Accurate, fast, low-cost method for measuring surface temperatures
- When desired temperature is reached, the mark quickly melts to a glossy, transparent-appearing liquid
- Accurate to +/-1% of stated temperature
- Ideal for applications such as annealing, forging, welding, bending, forming and any place where temperature measuring is necessary
- Meets ANSI/ASME guidelines



Priced per Heat Stik

Model No.	Mfg. No.	Temperature °F/°C	Price /Each
HK860	86517	200/93	18.50
434-7260	86562	250/121	18.50
HK887	86625	300/149	18.50
434-7410	86697	350/177	18.50

SOLID PAINT MARKERS FOR COLD SURFACES

B® PAINTSTIK®
The Original ALL Purpose
Cold Surface Marker -50° to 150°F



Real paint in stick form. Ideal for long-lasting, weather, fade and abrasion resistant identification. Leaves bright, highly visible marks on all materials, including asphalt, aluminum, glass, plastic, marble, lumber and steel. Writes on rough, smooth, oily, wet, icy and rusty surfaces.

Priced per Paintstik

Model No.	Colour	Price /Each
PA298	White	1.66
PA309	Yellow	1.71
PA320	Black	1.77

B-L® BLUE PAINTSTIK® -50° TO 150°F

Makes permanent marks that bleed through painted surfaces. Available in blue only. 12 dozen/case.

Priced per Paintstik

Model No.	Colour	Price /Each
PA356	Blue	5.85

PRO-LINE® HP PAINT MARKERS



- High performance paint marker has unsurpassed writing capabilities on oily, soapy and wet surfaces
- Excellent on most metals, coatings, plastics, glass, ceramics and other non-porous materials
- Low in halogenated compounds and sulphur allowing use in stainless steel and other corrosion sensitive applications



Priced per Marker

Model No.	Colour	Price /Each
PE507	White	4.39
PE508	Yellow	4.39
PE509	Red	4.39
PE510	Black	4.39

BALL PAINT MARKER®

-50° TO 150°F

Produce long lasting, weather and water resistant fine line marks with real paint that dries in minutes. Writes like a pencil on metal, wood, plastics, rubber - any surface or material. Packaged in unbreakable 2-oz. plastic bottles with cap to prevent drying or leaking.



Priced per Bottle

Model No.	Colour	Price /Each
PA339	White	9.36
PA340	Yellow	9.36

QUIK STIK™ TWIST-UP PAINT MARKERS

- All purpose paint marker for marking metal, wood, glass, plastic, cardboard and more
- Fast drying paint is fade and weather resistant
- 20% more marks than other brands
- Easy-to-use twist-up holder with self-storing cap keeps hands and clothing clean
- Available in four bright colours: White, yellow, red and black
- 72 per case



Priced per Marker

Model No.	Colour	Price /Each
PB937	White	8.75
PB938	Yellow	8.75
PB939	Red	8.75
PB940	Black	8.75

LUMBER CRAYONS

-50° TO 150°F

- Weather and fade-resistant lead-free marking
- Use on cardboard, ceramics, concrete, lumber (rough or smooth), metal, plastics, rubber, shipping room, storage containers



Priced per Crayon

Model No.	Colour	Price /Each
ECONOMICAL WAX BASED #200		
PA371	Black	1.44
PA367	White	1.44
PA368	Yellow	1.44

TRADES-MARKER® ALL PURPOSE MARKERS

RETRACTABLE GREASE PENCILS SUITABLE FOR ALL SURFACES

- Retractable grease pencil offers more convenience and longevity than a standard china marker
- Marks on plastic, glass, metal, wood, cardboard and paper
- Will not rub off and are weather-resistant
- Includes handy pocket clip
- Holder comes with five assorted colour refills
- Refills come six per package
- Two dozen per case



Priced per Marker

Model No.	Mfg. No.	Colour	Price/Each
HOLDER W/S REFILLS			
434-8980	96000	-	13.30
REFILLS, 6/PKG.			
434-9915	96009	Orange	7.59
434-8985	96042	White	7.59
434-9910	96043	Yellow	7.59
434-8995	96044	Black	7.59
434-9920	96045	Red	7.59

See pages 1443-1445 for full line of markers

METAL WORKING FLUIDS & EQUIPMENT

WELD-KLEEN® ANTI-SPATTER

- Base metal and fixture applications become easier to clean and remove unwanted weld spatter
- Regular use of these products reduces the need for grinding and other clean-up tasks
- Cuts costs by reducing downtime



WELD-KLEEN® 350°

- Effective water-based product designed for use on most base metal applications
- Economical and safe
- Biodegradable, non-toxic and paintable
- Can be frozen
- Available in a safe and convenient aerosol powered by air

WELD-KLEEN® HEAVY-DUTY

- A convenient solvent based, quick-drying aerosol that allows for pre-heat, higher duty cycles and higher temperature applications
- Excellent for fixture and tooling protection
- Paintable, non-flammable, no fluorocarbons

WELD-KLEEN® 350° SPRAYERS

- Hand sprayer with 36" lead tube for gallon container



388-1165

388-1170

388-1175

Model No.	Mfg. No.	Description	Size	Price /Each
TTT437	007088	Weld-Kleen® 350°	13.64-oz. Aerosol	13.50
388-1170	007089	Weld-Kleen® 350°	1 Quart	18.40
388-1175	007090	Weld-Kleen® 350°	1 Gallon	30.70
388-1185	007091	Weld-Kleen® 350°	5 Gallons	150.00
388-1180	007092	Weld-Kleen® 350°	55-Gallon Drum	1206.00
388-1165	007030	Weld-Kleen® H-D	20-oz. Aerosol	13.90
388-1155	007093	Sprayer for Weld-Kleen® 350°	--	8.51

LUBE-MATIC®

- Engineered to clean and lubricate wire, improve feedability, reduce spatter and increase tip and liner life
- Lube-Matic® pads and liquid help keep liners free of unwanted build-up and deposits inside the liner that cause wire drag
- Reduces wire drag by 60% and feeds wire more smoothly with poor cast, helix and rust
- Best when used together, as a system to clean and feed wire

LUBE-MATIC® LIQUID

- Helps feed all mild steel, fabricated, and core wires
- Cuts rust and reduces wire drag 60%
- Great for longer distance feed (over 10')

LUBE-MATIC® LUBE PADS

- Black lube pads are pre-treated with Lube Matic® liquid
- Lubrication allows smooth feeding of wires with poor cast, helix, rust and long feed liners

LUBE-MATIC® WIRE KLEENER® PADS

- Red Kleener® pads are for all wires all the time
- Last chance to clean wire and reduce burn back 50%



Model No.	Mfg. No.	Description	Size	Price /Each
388-1015	007040	Lube-Matic® Liquid	5 oz.	13.10
388-1010	007060	Lube-Matic® Lube Pads	6/Pkg.	16.40
388-1190	007061	Lube-Matic® Wire Kleener® Pads	6/Pkg.	14.80

NOZZLE-KLEEN®

- The accumulation of spatter on nozzles and tips can lead to poor gas coverage resulting in poor welds
- Preventing spatter build-up will increase weld quality and reduce costly downtime
- Maintain a clean nozzle
- Eliminate build-up with a spray or dip



388-1145

388-1150

NOZZLE-KLEEN® #2

- Highest quality for most applications
- Non-flammable and paintable
- No fluorocarbons

NOZZLE-KLEEN® HEAVY-DUTY

- Used for highest temperature applications including pulsed welding and argon rich mixtures
- Outstanding fixture protection
- Excellent for stainless steel
- Non-flammable, paintable no fluorocarbons and ozone friendly

Model No.	Mfg. No.	Description	Size	Price /Each
388-1150	007022	Nozzle-Kleen® #2	16-oz. Aerosol	10.70
388-1145	007020	Nozzle-Kleen® H-D	16-oz. Aerosol	13.50

SOAPSTONE HOLDERS



- Durable marking tools for holding fragile marking materials like soapstone and chalk
- Soapstone features highly visible white marking stick cut from natural stone which adheres to metal, stone, concrete and fabrics
- Pocket clip
- Sold with one soapstone installed

ROUND HOLDERS

- Aluminum adjustable holder for 1/4" x 5" soapstone or chalk

FLAT HOLDERS

- Steel adjustable holder for 1/4" x 5" flat soapstone or chalk
- Locking nut soapstone length adjustment



Model No.	Description	Price/Each
NT638	Round Holder	3.45
NT639	Flat Holder	3.05

SOAPSTONES

- White soapstone
- Sold in box quantity of 144

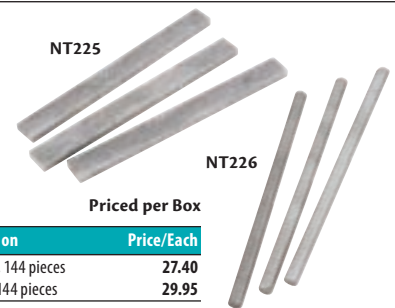

Priced per Box

Model No.	Description	Price/Each
NT226	Round Soapstone, 144 pieces	27.40
NT225	Flat Soapstone, 144 pieces	29.95

MIG WIRE CLEANING PADS



- Designed for use on all MIG wire feeders
- Removes dust and dirt from the wire prior to wire entry into the liner conduit
- Use of wire feed pads can decrease the coefficient of friction in the liner as much as 50%-60% and reduce erratic feed and burn backs
- Treated pads can be used on all alloyed wires except aluminum

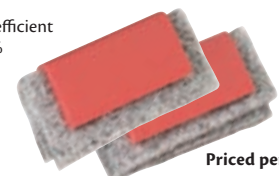

Priced per Package

Model No.	Qty/Pkg.	Price/Each
720-1000-KIT	6	9.31
720-1010-KIT	24	37.20

METAL WORKING FLUIDS & EQUIPMENT



DEFENSE ANTI-FREEZE & PUMP LUBRICANTS

- Provides year round pump protection for water coolers and closed loop water systems
- Contains a lubricant additive providing continuous pump lubrication during operation
- Prolongs seal and shaft life because of its silicate free formula
- Protects from freezing to -30°F when undiluted (a dilution of two parts Defense to one part water protects to -10°F) except for pre-mixed formula, protects to 10°F

Note: Although Defense is a permanent anti-freeze and pump lubrication solution, it should be changed annually to maintain maximum anti-freeze protection and pump lubrication.

DYNAFLUX
QUALITY PRODUCTS

Model No.	Mfg. No.	Size	Price /Each
881-1355	DF927-PM	1 Gallon, Pre-Mixed	31.70
881-1350	DF929-4x1	1 Gallon	49.80
881-1365	DF929-5	5-Gallon Pail	235.00
881-1370	DF929-55	55-Gallon Drum	2085.00



881-1355



881-1350

SPRAY GALV/COLD GALV

ZINC GALVANIZING COATING

- Produces hard zinc coating that will stop rust and corrosion on all metal surfaces
- Compounded from 95.1% metallic zinc dust
- Equal to hot dip galvanizing in cathodic protection and film durability
- Meets or exceeds military specs

DYNAFLUX
QUALITY PRODUCTS

Model No.	Mfg. No.	Description	Size	Price /Each
877-1125	DF309-16	Spray Galv	13-oz. Net Wt. Aerosol	12.30
877-1130	DF306-6x1	Cold Galv	1 Quart	109.00
877-1120	DF306-2x1	Cold Galv	1 Gallon	425.00



877-1120



877-1125

SPOTCHECK® PENETRANTS

- Red visible non-destructive test method which provides for the detection of surface discontinuities (flaws) in ferrous and non-ferrous test materials
- Ideal for applications where portability is required
- Vivid red colour permits daylight inspection

MAGNAFLUX®

SKL-SP2 PENETRANTS

- Exhibits outstanding penetrating characteristics, which provide for maximum reliability in locating surface-open flaws and discontinuities
- Can be used over the entire spectrum of industrial applications, where a visible penetrant inspection system meets the requirements for surface-open flaw detection
- Has also been successfully used on non-porous ceramics and similar materials
- Not recommended for the inspection of plastic materials, as it may stain, soften or even dissolve the base material under test
- Should be used at temperatures between 40°F-125°F



SKS-S SOLVENT CLEANERS

- Non-chlorinated cleaner/remover
- Used as a pre-cleaner, a post cleaner and a penetrant remover
- Recommended general purpose
- Meets major requirements for special alloy and nuclear applications

Model No.	Mfg. No.	Size	Price /Each
NP703	01-5750-78	16-oz. Aerosol	19.40

SKD-S2 SOLVENT DEVELOPERS

- Ready-to-use suspension of white developing particles in a fast drying solvent
- Non-chlorinated solvent developer
- Meets major requirements for special alloy and nuclear applications

Model No.	Mfg. No.	Size	Price /Each
NP702	01-5352-78	16-oz. Aerosol	23.50

ARDROX®

9D1B NON-AQUEOUS DEVELOPERS

- Liquid product consisting of a finely divided white powder dispersed in a non-halogenated volatile solvent system
- Can be used with Type I (fluorescent) and Type II (visible) penetrants

906 WATER WASHABLE VISIBLE PENETRANTS

- Visible penetrants are not rated by sensitivity but are generally considered to be equivalent to Level 1
- Provides low cost, crisp indications, low residual background and temperature stability
- Used with non-aqueous developers or aqueous developers
- May be applied by aerosol, brushing, tank immersion, conventional, electrostatic or spraying

9PR50 CLEANERS/REMOVERS

- Quick drying, non-halogenated (non-chlorinated) solvent for removing oil, grease and similar soils from metal surfaces
- Provides a high level of cleaning efficiency with operational safety
- Corrosion safe for use on both ferrous and non-ferrous alloys
- Excellent penetrant remover



874-1150

Model No.	Mfg. No.	Size	Price /Each
9D1B NON-AQUEOUS DEVELOPERS			
874-1150	9D1B-16	16-oz. Aerosol	33.10
906 PENETRANTS			
874-1080	906-16	16-oz. Aerosol	35.80
9PR50 CLEANERS/REMOVERS			
874-1180	9PR50-16	16-oz. Aerosol	28.00

METAL WORKING FLUIDS & EQUIPMENT

SOLAR® FLUX

- Formulated to shield the back of the weld joint from oxygen, dissipate heat and unwanted oxides and to clean the surface of metal
- Will aid in the flow of filler metal over base metal and form a protective barrier to prevent re-oxidization and heat scale
- To be mixed with alcohol (methanol/methyl alcohol preferred) and brushed on the back of the weld joint
- Inert, non-flammable and non-explosive
- Type B** for welding stainless steel and alloy steels



868-1000



Model No.	Mfg. No.	Description	Size	Price/Each
868-1000	SFB-1	Type B	1 lb	80.20

LIQUID GASFLUX®, TYPE "W"

- Liquid Gasflux® consists of a specially compounded liquid-type flux that is automatically introduced into the fuel gas
- Manufactured under rigid test requirements to guarantee its highest quality and performance
- Recommended for both manual and automatic brazing applications and works with all fuel gases
- Standard liquid flux for most all silver and bronze brazing
- Suitable with almost all applications for the brazing of copper, brass, steel, stainless steel, cast iron and carbide
- Conforms to AWS/ANSI A5.31, American Welding Society "Specification for Brazing Fluxes" and falls under flux type FB3-K



870-1092

Model No.	Mfg. No.	Size	Price /Each
870-1092	GF-1	1 Gallon	60.80
870-1096	GF-5	5-Gallon Pail	280.00
870-1100	GF-55	53-Gallon Drum	2718.00

ACID/FLUX BRUSHES

- Perfect brushes for applying liquid or paste flux



Model No.	Mfg. No.	Width"	Trim Length"	Overall Length"	Price /Each
BY189	74059	1/4	11/16	6	0.19
BY190	74060	3/8	7/8	6 1/8	0.19
BY191	74061	7/16	7/8	6 1/8	0.19
BY192	74062	9/16	7/8	6 1/8	0.24

ULTRA BRIGHT ALUMINUM CLEANERS

- Ready-to-use cleaner and brightener
- Provides rapid and effortless cleaning and removal of aluminum oxides, grease and dirt from aluminum before welding
- Rinse agents provide a "sheeting" action for film-free rinsing
- Heavy accumulations may require some light brushing
- Biodegradable



NP597



NP596



Model No.	Mfg. No.	Size	Price /Each
NP597	DF781-12x1	1 Quart	12.20
NP596	DF781-4x1	1 Gallon	32.80
877-1190	DF781-55	55-Gallon Drum	1197.00

NOZZLE GEL

- For MIG gun nozzles and contact tips
- Suitable for use on fixtures of semi-automatic and automatic welding equipment
- Non toxic, odourless
- Not flammable, silicone free



Model No.	Mfg. No.	Size	Price /Each
720-1071	DF731-16	16-fl. oz. Jar	8.51



SAFE-DE-SPAT

ANTI-SPATTER & NOZZLE SHIELD

- Prevents weld spatter from adhering to MIG nozzles, contact tips and related accessories as well as weld spatter build-up on metals to be joined
- Non-flammable, non-toxic, biodegradable and silicone free
- Non-solvent based
- Paint compatible
- Designed to provide a safe welding environment



Model No.	Mfg. No.	Size	Price /Each
876-1005	DF390-16	16-oz. Net Wt. Aerosol	7.60
876-1000	DF390-4x1	1 Gallon	30.80
876-1020	DF390-5	5-Gallon Pail	157.00
876-1025	DF390-55	55-Gallon Drum	1595.00



876-1005

BLUE LAYOUT FLUIDS

- A firm gripping, oil resistant blue pigmented layout fluid
- Designed for use on all types of metal surfaces, plastics and glass
- Dries instantly to a non-glaze smooth finish
- Provides fine lines for detail and high precision
- Contains no acids and is non-corrosive, flammable



Model No.	Mfg. No.	Size	Price /Each
881-1100	DF304-16	11.5-oz. Net Wt. Aerosol	16.40





BIO-RUST NEUTRAL PH RUST REMOVERS

- Removes rust and other metallic particles
- VOC free, solvent free, non-flammable, pH neutral solution biodegradable
- Not controlled under WHMIS
- Non-corrosive rust remover
- High workload - can remove 1.5 kg (3.3 lbs.) of iron oxide per 20 L
- For use with iron and mild steel
- Deeply rusted parts may require longer soaking time
- After application of Bio-Rust, rinse parts in water to remove loosened contaminants
- After removing rust, dip pack into fresh bath or Bio-Rust to provide short term corrosion protection
- It is recommended to degrease part before using Bio-Rust
- Bio-Rust is designed for immersion applications only
- Immerse parts in Bio-Rust at room temperature and let react for at least 30 minutes



Model No.	Mfg. No.	Size Litres	Gallons	Price /Each
AD441	53-G-247	20	5.2	347.95
AD442	53-G-248	208	55	3105.00

LPS 3[®] HEAVY-DUTY INHIBITORS

- Protects up to two years
- Stops rust and corrosion
- Provides non-sling lubrication
- Non-flammable propellant
- Self-healing, waxy film
- Provides anti-seize coating
- Safe to use on rubber, fabric, plastics and paints
- Meets or exceeds these specs: Boeing BMS-3 23F Type II, MIL-C-0083933A, para.3.2-3.16, MIL-C-16173D Grade 2 Class I, DMS 2150, Airbus TN A. 007.10138 Type I Grade 2
- Accepted for use in Canadian food processing facilities



Model No.	Mfg. No.	Size	Price /Each
AA808	C00316	11 oz.	23.50
AB559	C00322	20-oz. Trigger	30.90
AB558	C03128	1 gal.	110.00
AB556	C00305	5 gal.	461.00
AB557	C00355	55 gal.	4549.00

COLD GALVANIZING COMPOUND

- 93% pure zinc coating provides maximum corrosion resistance and excellent adhesion and durability on galvanized metal
- Use to touch-up/repair galvanized ducts, storage tanks, fences, gutters, etc.
- VOC Compliant
- Finish: Gloss
- Max Operating Temperature: 200°F
- Series: Industrial Choice 1600



RUST-OLEUM

Model No.	Mfg. No.	Size	Price /Each
KP448	1685830	14 oz.	9.97

EVAPO-RUST™ RUST REMOVERS

- Removes rust quickly without scrubbing
- Dipping process
- Non-toxic, non-corrosive, non-flammable
- VOC free
- Water-soluble, biodegradable, safe on skin
- Contains no acids, bases or solvents
- Will not harm unrusted metals



Model No.	Mfg. No.	Size	Price /Each
AD049	ER1	1 L	10.80
AD050	ER4	3.78 L	32.10
AD051	ER20	18.9 L	155.00
AD052	ER205	205 L	1355.00

ZINC-RICH GALVANIZING COMPOUNDS

- Fast-drying, high-solids, high performance, epoxy-based coating
- Provides maximum protection to steel exposed to severe corrosive environments
- Fuses zinc to the metal substrate to protect against corrosion; equal to or better than hot-dipped galvanizing
- 97%-pure zinc dust
- May be topcoated with conventional primers or finish coats
- For fences, gutters, bridges, structural steel, wrought iron, farm equipment; ideal as a maintenance spray for highways, food plants, power plants, refineries or damaged galvanized surfaces



Model No.	Mfg. No.	Size	Price /Each
AA029	C00740000	14 oz.	10.40

COLD GALVANISED CORROSION INHIBITORS

- 95% zinc-rich galvanized coating
- Commonly used as a flash rust preventative on welded areas
- Works like a hot-dip on ferrous metals indoors and out
- Three-year protection
- Withstands water temperature up to 212°F (100°C) and continuous dry heat up to 750°F (400°C)
- Flexible coating will not yellow, chalk, crack or peel
- Electrochemically protect bare metal
- Meets or exceeds these specs: MIL-P-46105 Weld Through Primer, Passes Preece Test for Hot-Dip Galvanizing



Model No.	Mfg. No.	Size	Price /Each
AA807	C00516	14-oz.	19.60
AB552	C05128	1 gal.	410.00

EXTEND® RUST TREATMENTS

- Goes on white and converts rust to a durable, black, metal-protective coating in 10 minutes
- Wirebrush parts and apply with brush or spray
- Surface rust must be present
- Use as a primer or finish coat
- Resists temperatures to 250°F intermittent, 200°F continuous
- Approved by the American Bureau of Shipping



Model No.	Mfg. No.	Size	Price /Each
AA632	30539	10.5 oz. aerosol	13.30
AA633	75430	1 qt. bottle	46.90
AA634	75448	1 gal. bottle	162.00
AC110	75465	5 gal. pail	709.00

MAXI-COAT RUST INHIBITOR

- Heavy-duty coating that provides long-term protection for metal parts, equipment, and machinery
- Forms a protective, waxy film which seals out moisture, air, acid, and other corrosive elements
- Great for protecting parts in storage
- Container Type: Aerosol



Model No.	Mfg. No.	Size	Price /Each
AA599	51211	16 oz.	15.10

BRIGHT COAT COLD GALVANIZED CORROSION INHIBITORS

- Shiny zinc coating
- Prevents rust and corrosion on all metals
- Restores hot dip galvanizing
- Dries to touch in 15 to 30 minutes
- Repairs rusted, galvanized and welded surfaces
- Electrochemically protects bare metal
- Heat resistant, flexible coating
- Will not yellow, chalk, crack or peel



Model No.	Mfg. No.	Size	Price /Each
AB485	C05916	13 oz.	16.60

METAL WORKING FLUIDS & EQUIPMENT

SILVER GALVANIZING COMPOUNDS

- Sacrificial coating that inhibits corrosion on ferrous metals
- Excellent touch-up for repair of galvanized substrates
- Produces a dry coating with the bright finish of hot-dip galvanizing
- Recommended dry film thickness of 1.5 to 3.0 mils VOC-compliant
- Dries to touch in 30 minutes
- May be recoated after 2-16 hours, or after 36 hours
- For food plants, automotive plants, refineries, nuclear facilities, power plants and transmission towers; fences, gutters, bridges, structural steel, wrought iron, farm equipment galvanized surfaces; highway maintenance and marine applications



Model No.	Mfg. No.	Size	Price /Each
AA185	C00739000	14 oz.	16.30

E-WELD NOZZLE ANTI-SPATTER

- Maximum Operating Temperature: 1832°F (1000°C)
- Ceramic anti-spatter that protects welding nozzles
- Provides unrivaled protection of welding nozzles in manual, semi-automated and fully-automated MIG welding applications
- Reduces downtime by extending nozzle life
- Protects welding nozzles for 8 hours
- At least 125 uses with applicator



Model No.	Mfg. No.	Size	Description	Price /Each
AF017	53F512	400 ml	-	40.70
VV928	53L121	-	Applicator	19.00
VV929	53F912	-	Aerosol & Applicator Kit	48.95

WELDER'S STAINLESS STEEL PROTECTIVE COATING

- Provides maximum corrosion resistance on metal, chrome, ceramic and copper surfaces
- Formulated with 100% Type 316L stainless steel pigment
- Dries quickly to a satin sheen
- Hardens overnight and cures in just a few days
- Use to cover discoloration in weld areas
- For exhaust and steam pipes, mufflers, radiators, production equipment, engines, furnaces, plumbing fixtures, chemical processing equipment



Model No.	Mfg. No.	Size	Price /Each
AA027	C00738000	12 oz.	9.36

DRY WELD SPATTER PROTECTANTS

- Prevents spatter from sticking to metal surfaces during welding
- Easily removed by brushing or wiping
- Does not contain silicone
- Surface may be painted after use
- For all types of maintenance and production welding, construction, body shops



Model No.	Mfg. No.	Size	Price /Each
AC303	C00541000	16 oz.	7.18

ANTI-SPATTER

- Safe, water-based formula
- Excellent spatter protection
- Non-toxic
- Non-flammable
- Does not contain suspect carcinogens such as methylene chloride
- Does not contain silicone
- Paint compatible
- Accepted for use in Canadian food processing facilities



Model No.	Mfg. No.	Size	Price /Each
AA816	C02116	13 oz.	9.32

CATALOGUE PRICING

The prices shown in this catalogue are for "REFERENCE AND BUDGET PURPOSES ONLY" as of July 2016, and should be used exclusively as a guideline.

SPECIAL ORDERS

This catalogue represents only a portion of the products that are available to you. If you can't find what you need, please call us!

E-WELD WELD SPATTER RELEASE EMULSIONS

- Effectively protects work pieces and welding equipment (such as torches, robots and jigs) eliminating costly spatter removal work
- Best for general purpose welding
- Contains temporary corrosion inhibitors
- Prevents weld spatter from sticking
- Ultrafine spray for complete coverage
- Will not harm painted surfaces
- Can be used on all weldable metals
- Green colour for a better view on work piece



Model No.	Mfg. No.	Description	Metric	Imperial	Price /Each
AA903	53-F 002	Aerosol	500 ml	16.9 fl.oz.	11.20
AC300	53-F 203	Trigger Spray	500 ml	16.9 fl.oz.	13.10
AA474	53-F 206	Liquid	5 L	1.3 gal	100.95
AA475	53-F 207	Liquid	20 L	5.2 gal	355.45
AC301	53-F 208	Liquid	208 L	55 gal	1338.35

E-WELD 3 WELD SPATTER RELEASE SOLUTIONS

- Unique, high performing anti-spatter solution that protects work pieces from adherence of high energy spatter and eliminates costly spatter removal operations
- Can also be used to clean and degrease surfaces prior to welding
- Formulated to prevent spatter adhesion for high temperature welding applications such as: stainless steel welding, multiple pass welding, thin sheet welding and welding pre-heated work pieces
- For MIG and Arc welding applications, as well as plasma cutting
- Water base formulation - biodegradable, non-flammable, odourless
- Compatible with aluminum, steel and stainless steel
- VOC free, solvent free and silicone free
- Contains corrosion inhibitors for short term corrosion protection
- Excellent paint adhesion properties - no special cleaning required for post welding coating operations



Model No.	Mfg. No.	Description	Metric	Imperial	Price /Each
AA506	53-F 253	Trigger Spray	500 ml	16.9 fl.oz.	14.75
AA507	53-F 256	Liquid	5 L	1.3 gal	114.55
AA508	53-F 257	Liquid	20 L	5.2 gal	389.75
AC309	53-F 258	Liquid	208 L	55 gal	2141.35

METAL WORKING FLUIDS & EQUIPMENT



CLEAR INSULATING VARNISHES

- Thoroughly penetrates old and new materials
- Air-dries faster than most insulating aerosols (10-15 min)
- Tack-free in 60 minutes
- Provides high adhesion, high arc resistance and non-tracking properties
- For use as an insulating varnish in Class F applications, as well as a finish coat
- Resists abrasion and wear
- Contains no chlorinated solvents



Model No.	Mfg. No.	Size	Price /Each
AA178	C0060000	15.25 oz.	9.31

RED INSULATING VARNISHES

- Penetrates thoroughly and forms a tough, flexible film
- High arc resistance and non-tracking properties
- Resists oil, water, acids and alkalis
- Excellent adhesion
- Oil resistant per ASTM-D-115-55



Model No.	Mfg. No.	Size	Price /Each
AA179	C00601000	15.25 oz.	9.31

BLUE LAYOUT DYES

- The economical choice for most layout projects
- VOC-compliant
- Fast-drying, non-flaking, non-etching, won't peel
- Heat resistant, non-corrosive
- Adheres to metal or glass
- For pattern-making, tool and die making, machining and maintenance mechanicals



Model No.	Mfg. No.	Size	Price /Each
AA180	C00603000	12 oz.	9.02

LAYOUT DYE REMOVERS

- Removes layout fluids quickly and efficiently
- Removes light oils, greases, lacquer and other markings on metal or glass
- Leaves no residue
- No chlorinated solvents
- For tool and die making and production departments



Model No.	Mfg. No.	Size	Price /Each
AA181	C00606000	12.75 oz.	8.51

A-9 ALUMINUM CUTTING FLUIDS

- Designed for aluminum, non-ferrous metals
- Forms an effective extreme pressure boundary lubricant between tool and work surface
- Leaves a surface, which requires only ordinary cleaning

RELTON



Model No.	Size	Price /Each
AA149	4 oz.	3.80

RAPID TAP™ CUTTING FLUIDS

- Effective on tough-to-drill metals and alloys such as beryllium, molybdenum, stainless steel and stellite
- Makes tapping, reaming, drilling and threading operations easier, faster and more accurate
- Not recommended for use with aluminum and its alloys

RELTON



Model No.	Size	Price /Each
AA160	4 oz.	5.45

COOLCUT™

- Extends cutting tool life
- Suitable for all ferrous and non-ferrous metals
- Produces a better finish
- Solvent-free, no chlorine
- For drilling, sawing, milling, turning, reaming, broaching



METAL CUTTING LIQUID

Model No.	Mfg. No.	Size	Price /Each
AA468	53-B-003	350 ml	12.20
AA469	53-B-006	4 L	96.90
AA470	53-B-007	20 L	360.30
AB748	53-B-008	208 L	2539.10

METAL CUTTING STICKS

Model No.	Mfg. No.	Size	Price /Each
AA471	53-B-013	300 g	16.85

METAL CUTTING SPRAYS

Model No.	Mfg. No.	Size	Price /Each
AA467	53-B-002	350 ml	22.25



AA468



AA471



AA467

OPTION 1® CUTTING FLUIDS

- Effective in all machining operations on all metals except those that are water reactive
- Water-based
- Biodegradable
- No oil
- No chlorine - no sulfur, no toxic chemicals

RELTON



Model No.	Size	Price /Each
AA156	4 oz.	3.86

SF 7900™ CERAMIC SHIELD FOR WELDING

- Ceramic dry film protective coating for MIG/MAG welding processes
- Protects contact tips and welding nozzles by preventing adhesion of welding spatter
- Once applied the coating dries by solvent evaporation within 5 to 10 seconds at room temperature (Thicker films will need longer drying time)
- Ceramic, silicone-free protective coating, easy to apply
- Protects contact tips, welding nozzles and jigs, eliminating cost for cleaning equipment
- Reduces running costs for consumables by up to 40%
- Prevents adhesion of welding spatter for many hours with just one application
- Colour: White

LOCTITE



Model No.	Mfg. No.	Size	Price /Each
AD492	1616692	9.5 oz.	35.70

METAL WORKING FLUIDS & EQUIPMENT

TAPMATIC® EDGE CREME

- Excellent for vertical applications
- Biodegradable
- Can be applied to cutting tools before tapping or reaming
- For use when drilling, tapping blind holes, forming, bending, pre-coating fasteners and lubricating rubber seals
- Does not contain any hazardous chemicals
- Safe on all metals



Model No.	Mfg. No.	Size	Price /Each
AA923	C43100	11 oz.	29.90

STAINLESSCUT™ EXTREME PRESSURE CUTTING LUBRICANTS

- Prolongs tool life in stainless and other tough alloys
- Produces a better finish
- Safe and pleasant to use



Model No.	Description	Size	Price /Each
AA509	Aerosol	400 ml	24.95
AA510	Squeeze bottle	350 ml	15.50
AA511	Liquid	4 L	119.35

CIMTAP® II LIQUID TAPPING COMPOUNDS

- Water-soluble, formulated for blind holds, deep vertical holes and high production operations requiring quick application
- For ferrous and non-ferrous metals



Model No.	Size	Price/Each
AB792	16-oz. Bottle	12.40
AB789	4-L Jug	51.00

TAPMATIC® #1 GOLD CUTTING FLUIDS

- Great for steel and aluminum
- Excellent for low speed, high pressure applications
- Minimizes torque increases
- No chlorinated paraffins, water, solvents or inactive fillers
- Aerosol provides a pinpoint stream with foaming action
- Safe on all metals
- Accepted for use in Canadian food processing facilities



Model No.	Mfg. No.	Size	Price /Each
AA775	C40312	11-oz. Aerosol	19.90
AA776	C40320	16 oz.	20.40
AB565	C40330	1 gal.	112.00
AB563	C40340	5 gal.	456.00

TAPMATIC® TRICUT CUTTING FLUIDS

- Excellent for hard to machine metals
- Not recommended for aluminum
- Provides, smooth, accurate cutting action
- Flows directly to cutting edge
- Extends tool life
- Reduces friction
- Suitable for high and low speed applications
- Non-corrosive to steel



Model No.	Mfg. No.	Size	Price /Each
AA779	C05316	16 oz.	27.20
AB578	C05328	1 gal.	189.00

TAPMATIC® EDGE LUBE

- White, solid waxy bar
- Excellent for belt, wheel and disc grinding or sawing applications
- Eliminates heat build-up and belt loading
- No hazardous chemicals
- Extends grinding wheel life
- Low toxicity
- Safe on all metals



Model No.	Mfg. No.	Size	Price /Each
AA922	C43200	13 oz.	27.60

TAPMATIC® AQUACUT CUTTING FLUIDS

- Water-based formula
- Excellent in applications where cooling of the tool is desired
- Does not contain sulfur, chlorinated solvents, chlorine or oils
- Safe on all metals, except magnesium
- Corrosion inhibitors prevent flash rusting
- Provides fine finishes
- Cinnamon scent



Model No.	Mfg. No.	Size	Price /Each
AA778	C01216	16 oz.	16.80
AB574	C01228	1 gal.	67.60
AB572	C01205	5 gal.	354.00

TAPMATIC® NATURAL CUTTING FLUIDS

- Non-toxic and non-hazardous
- Biodegradable
- Does not irritate the skin, eyes or respiratory tract
- Does not contain sulfur, chlorinated solvents, chlorine water, mineral oil or inactive fillers
- Great for steel and aluminum
- High performance lubricating ability eliminates galling and seizing
- Safe on all metals





























































Model No.	Mfg. No.	Size	Price /Each
AA777	C44220	16 oz.	18.70
AB577	C44230	1 gal.	111.00



METAL WORKING FLUIDS & EQUIPMENT

1/4" SYSTEM - 1/4" INSIDE DIAMETER (CONT'D)

Model No.	Mfg. No.	Description	Price/Each
AA305	41472	 1/4" 90° Nozzle Pack of 4	13.10
AA306	49441	 Pack of 20	51.70
AA279	41473	 1/4" 90° Spray bar nozzle Pack of 2	14.30
AA307	49442	 Pack of 20	99.90
AA277	41407	 1" Flare nozzle Pack of 2	14.00
AA308	49427	 Pack of 20	99.90
AA275	41405	 1/8" NPT Connector Pack of 4	9.26
AA309	49425	 Pack of 50	92.40
AA310	41417	 1/8" BSPT* Connector Pack of 4	9.34
AA311	49437	 Pack of 50 * British Standard Pipe Thread	92.40
AA276	41406	 1/4" NPT Connector Pack of 4	9.26
AA312	49426	 Pack of 50	92.40
AA313	41418	 1/4" BSPT* Connector Pack of 4	9.34
AA314	49438	 Pack of 50 * British Standard Pipe Thread	92.40
AA278	41408	 1/4" Y fitting Pack of 2	14.30
AA315	49428	 Pack of 20	99.90
AA316	41409	 1/4" Double socket Pack of 4	10.40
AA317	49429	 Pack of 20	41.20
AA318	41411	 1/4" Socket to 1/8" FNPT Pack of 4	11.80
AA319	49431	 Pack of 20	47.00
AA320	41412	 3/8" SAE Flare nut adapter Pack of 4	14.30
AA321	49432	 Pack of 20 • 5/8" - 18 Thread	55.40
AA322	41414	 1/4" SAE Flare nut adapter Pack of 4	14.30
AA323	49434	 Pack of 20 • 7/16" - 20 Thread	55.40
AA324	41415	 1/4" Elbow fitting Pack of 2	13.10
AA325	49435	 Pack of 20	102.00
AA326	41416	 1/4" T fitting Pack of 2	15.80
AA327	49436	 Pack of 20	122.00
AA328	41478	 1/4" Side flow nozzle Pack of 4	15.80
AA329	49443	 Pack of 20	58.10
AA330	41480	 1/4" End cap Pack of 4	9.34
AA331	49447	 Pack of 20	37.00
AA332	41481	 1/4" Swivel nozzle 40 Pack of 2	21.10
AA333	49449	 Pack of 20 • 0.040 Hole diameter	168.00

Model No.	Mfg. No.	Description	Price/Each
AA334	41482	 1/4" Swivel nozzle 60 Pack of 2	21.10
AA335	49450	 Pack of 20 • 0.060 Hole diameter	168.00
AC407	41488	 2 1/2" Swivel nozzle 75 Pack of 2	22.10
AC374	49455	 Pack of 20 • 0.075 Hole diameter	178.00
AC418	41489	 1" Straight flow nozzle Pack of 2	14.30
AC381	49456	 Pack of 20	99.90
AA269	21192	 1/4" Male NPT valve* Pack of 2	23.50
AA338	29452	 Pack of 10	105.00
AA339	21193	 1/4" Female NPT valve* Pack of 2	23.70
AA340	29453	 Pack of 10	105.00
AA270	21194	 1/4" In-line valve* Pack of 2	23.50
AA341	29454	 Pack of 10	105.00
AA336	21191	 In-line check valve Pack of 2	23.70
AA337	29451	 Pack of 10	105.00
AC413	41483	 1/4" Flat slot 40 nozzle Pack of 4	15.10
AC394	49451	 Pack of 20 • 0.040 Slot height	60.00
AC414	41484	 1/4" Flat slot 60 nozzle Pack of 4	15.10
AC395	49452	 Pack of 20 • 0.060 Hole diameter	60.00
AC415	41485	 1/4" Flat 5 hole nozzle Pack of 4	15.10
AC396	49453	 Pack of 20 • 0.060 Slot height	60.00
AC416	41486	 1/4" Flat 7 hole nozzle Pack of 4	15.10
AC397	49454	 Pack of 20 • 0.040 Hole diameter	60.00
AC417	41487	 1/4" Flat nozzle assortment pack Includes one each of: Flat slot 40 nozzle Flat slot 60 nozzle Flat 5 hole nozzle Flat 7 hole nozzle	15.10
AA342	78001	 1/4" Hose assembly pliers One 1/4" pliers	24.70
AC398	78003	 1/4" and 1/2" pliers set	44.80



















*1/4" VALVE SPECIFICATIONS:



















- Full 1/4" inside diameter
- Maximum working pressures:
1/4" hose: 30 PSI
1/4" In-line valve: 30 PSI
1/4" Male and female NPT valves: 100 PSI
- **Body and stern material:**
Acetal Copolymer
Stern seal: Nitrile (Buna-N)
- 1/4 turn shut off
(1/4" hose limits most applications to 30 PSI)

METAL WORKING FLUIDS & EQUIPMENT





1/2" SYSTEM - 1/2" INSIDE DIAMETER



Model No.	Mfg. No.	Description	Price/Each
AA231	50813	 1/2" Hose kit 13" length with fittings: 2 segments, 5 1/2" long 1/4", 3/8", 1/2" nozzles 3/8" and 1/2" male NPT connectors	21.10
AA343	51832	 1/2" 90° Nozzle kit 1 each: 1/4", 3/8", 1/2" and spray bar nozzles	17.80
AA344	51835	 1/2" Extended element kit with element clamps Includes 4 each of 1/2" extended elements 1/2" element clamps	36.90
AA419	51837	 1/2" Circle flow nozzle kit Assembled with 15 side flow nozzles 1/2" and 1 end cap 1/2"	47.30
AA345	51801	 1/2" Segment pack 2 - Segments, 5 1/2" long	15.20
AA346	59860	Bulk 25 ft., 59 Segments	350.00
AA347	59861	1/2" 50 Foot Coil	699.00
AA348	51833	 1/2" Extended element Pack of 4	23.70
AA349	59883	Pack of 20	94.50
AA350	51834	 1/2" Element clamp Pack of 4 (w/screws)	18.30
AA351	59884	Pack of 20 (w/screws)	68.40
AA284	51806	 1/4" Round nozzle for 1/2" Pack of 4	10.70
AA352	59866	Pack of 50	106.00
AA280	51802	 3/8" Round nozzle Pack of 4	10.70
AA353	59862	Pack of 50	106.00
AA281	51803	 1/2" Round nozzle Pack of 4	10.70
AA354	59863	Pack of 50	106.00
AA355	51828	 1/4" 90° nozzle Pack of 4	14.90
AA356	59878	Pack of 20	59.30
AA357	51829	 3/8" 90° nozzle Pack of 4	14.90
AA358	59879	Pack of 20	59.30
AA359	51830	 1/2" 90° nozzle Pack of 4	14.90
AA360	59880	Pack of 20	59.30
AA361	51831	 1/2" 90° Spray bar nozzle Pack of 2	16.00
AA362	51881	Pack of 20	110.00
AA363	51807	 1 1/4" Flare nozzle Pack of 2	16.00
AA364	51867	Pack of 20	110.00
AA365	51809	 2 1/2" Flare nozzle Pack of 2	18.30
AA366	59871	Pack of 20	121.00
AA282	51804	 3/8" NPT Connector Pack of 4	10.70
AA367	59864	Pack of 50	106.00
AA368	51826	 3/8" BSPT* Connector Pack of 4	10.70
AA369	59876	Pack of 50 * British Standard Pipe Thread	106.00

Model No.	Mfg. No.	Description	Price/Each
AA283	51805	 1/2" NPT Connector Pack of 4	10.70
AA370	59865	Pack of 50	106.00
AA371	51827	 1/2" BSPT* Connector Pack of 4	10.70
AA372	59877	Pack of 50 * British Standard Pipe Thread	106.00
AA285	51808	 1/2" Y Fitting Pack of 2	16.00
AA373	59868	Pack of 20	110.00
AA374	51822	 1/2" to 1/4" Y reducer Pack of 2	16.00
AA375	59870	Pack of 20	110.00
AA376	51821	 1/2" to 1/4" Adaptor Pack of 2	11.70
AA377	59869	Pack of 20	99.90
AA378	51811	 1/2" Double socket Pack of 4	11.80
AA379	59872	Pack of 20	47.00
AA380	51823	 3/8" SAE Flare nut adaptor Pack of 4	14.70
AA381	59873	Pack of 20 • 5/8" - 18 Thread	57.60
AA382	51824	 1/2" Elbow fitting Pack of 4	14.90
AA383	59874	Pack of 20	116.00
AA384	51825	 1/2" T fitting Pack of 2	17.60
AA385	59875	Pack of 20	137.00
AA386	51836	 1/2" Side flow nozzle Pack of 4	17.80
AA387	59889	Pack of 20	64.70
AA388	51838	 1/2" End cap Pack of 4	10.70
AA389	59885	Pack of 20	42.10
AC406	51845	 1/2" Swivel nozzle 75 for 1/2" Pack of 2	23.30
AC373	59895	Pack of 20 • 0.075 Hole diameter	187.00
AA390	32091	 1/2" In-line check valve Pack of 2	28.90
AA391	39851	Pack of 10	129.00
AA271	32092	 1/2" Male NPT valve* Pack of 2	28.90
AA392	39852	Pack of 10	129.00
AA393	32093	 1/2" Female NPT valve* Pack of 2	28.90
AA394	39853	Pack of 10	129.00
AA272	32094	 1/2" In-line valve* Pack of 2	28.90
AA395	39854	Pack of 10	129.00
AA396	78002	 1/2" Hose assembly pliers One 1/2" pliers	24.70
AC398	78003	1/4" and 1/2" pliers set	44.80
AC408	51840	 1/2" Flat slot 80 nozzle Pack of 4	16.70
AC389	59890	Pack of 20 • 0.080 Slot height	67.00
AC409	51841	 1/2" Flat slot 125 nozzle Pack of 4	16.70
AC390	59891	Pack of 20 • 0.125 Slot height	67.00

METAL WORKING FLUIDS & EQUIPMENT

1/2" SYSTEM - 1/2" INSIDE DIAMETER (CONT'D)







Model No.	Mfg. No.	Description	Price/Each
AC410	51842		1/2" Flat 5 hole nozzle
AC391	59892		Pack of 4 Pack of 20 • 0.125 Hole diameter
AC411	51843		1/2" Flat 7 hole nozzle
AC392	59893		Pack of 4 Pack of 20 • 0.080 Hole diameter
AC412	51844		1/2" Flat nozzle assortment
			Includes one each of:
			Flat slot 80 nozzle
			Flat slot 125 nozzle Flat 5 hole nozzle Flat 7 hole nozzle







Model No.	Mfg. No.	Description	Price/Each
AC426	51895		1/2" Fixed mount
AC383	59896		Pack of 2 Pack of 20 • Mounts with 1/4" bolt, not included
AC403	51846		1/2" Magnetic base
			Pack of 1 • 60 # holding force

*1/2" VALVE SPECIFICATIONS:

- Full 1/2" inside diameter
- Maximum working pressures:
1/2" hose: 20 PSI
1/2" In-line valve: 20 PSI
1/2" Male and female NPT valves: 100 PSI
- **Body and stern material:** Acetal Copolymer
- **Stern seal:** Nitrile (Buna-N)
- 1/4 turn shut off (1/2" hose limits most applications to 20 PSI)

3/4" SYSTEM - 3/4" INSIDE DIAMETER





Model No.	Mfg. No.	Description	Price/Each
AA232	60513		3/4" Hose kit
			14" length with fittings
			2 - segments, 5 3/4" long 5/8" and 3/4" nozzles 3/4" male NPT connector
AA397	61501		3/4" Segment Pack
AA398	69540		2 - segments, 5 3/4" long
AA399	69541		Bulk 25 ft., 54 Segments 3/4" 50 foot Coil
AA400	61503		5/8" Round nozzle
AA401	69543		Pack of 4 Pack of 50
AA402	61502		3/4" Round nozzle
AA403	69542		Pack of 4 Pack of 50
AA404	61507		3" Flare nozzle
AA405	69547		Pack of 2 Pack of 20
AA406	61505		3/4" NPT connector
AA407	69545		Pack of 4 Pack of 50







Model No.	Mfg. No.	Description	Price/Each
AA408	61509		3/4" BSPT* connector
AA409	69549		Pack of 4 Pack of 50 * British Standard Pipe Thread
AA410	61511		3/4" Y fitting
AA411	69551		Pack of 2 Pack of 20
AA412	61512		3/4" to 1/2" Y reducer
AA413	69552		Pack of 2 Pack of 20
AA414	61508		3/4" to 1/2" adapter
AA415	69548		Pack of 2 Pack of 20
AA416	61514		3/4" Double socket
AA417	69554		Pack of 4 Pack of 20
AC400	78004		3/4" Hose assembly pliers
			Pack of 1

Shields & Modular Manifolds Kits - Also Available

VACUUM HOSES

The Loc-Line® 2 1/2" Vacuum hose is designed to be added to an existing central vacuum system to extract smoke, dust, fumes and particles at the source. It is easy to position within a work area and can be mounted to 3" thin walled PVC drain pipe, 3" sheet metal duct, or a portable shop vacuum.

Model No.	Mfg. No.	Description	Price/Each
AC401	81201		Vacuum segment packs
AC399	81301AS		9 elements 2.5" I.D. Anti-static, 9 elements (1 foot segment)
AC393	81202		18 elements 2.5" I.D.
AC388	81302AS		Anti-static, 18 elements (2 - one foot segments)
AC370	89220		180 elements 2.5" I.D.
AC369	89320AS		Anti-static, 180 elements (20 - one foot segments)
AC422	81203		4.5" Round nozzle
AC419	81303AS		Pack of 1
AC378	89223		Anti-static, pack of 1
AC375	89223AS		Pack of 10 Anti-static, pack of 10
AC423	81204		6" x 3.5" Rectangular nozzle
AC420	81304AS		Pack of 1
AC379	89224		Anti-static, pack of 1
AC376	89324AS		Pack of 10 Anti-static, pack of 10

Model No.	Mfg. No.	Description	Price/Each
AC424	81205		Tapered oval nozzle
AC421	81305AS		Pack of 1
AC380	89225		Anti-static, pack of 1
AC377	89325AS		Pack of 10 Anti-static, pack of 10
AC425	81206		3" PCV adapter
AC384	89226		Pack of 1 Pack of 10 * Not available in "anti-static"
AC428	81207		3" Sheet metal duct adapter
AC427	81307AS		Pack of 1
AC385	89227		Anti-static, pack of 1
AC382	89327AS		Pack of 10 Anti-static, pack of 10
AC404	81208		2.5" Slide valve
AC402	81308AS		Pack of 1
AC372	89228		Anti-static, pack of 1
AC371	89328AS		Pack of 10 Anti-static, pack of 10
AC429	81209		Shop vacuum hose adapter
AC386	89229		with mounting tab Pack of 1 Pack of 10
AC430	81210		Shop vacuum adapter
AC387	89230		Pack of 1 Pack of 10

Shields & Modular Manifolds Kits - Also Available

3M

ADF Filters.....	1126
Adhesive Bandages.....	741
Ambient Air Pump Respirators.....	466, 481, 1127
Anti-Skid Tape.....	873
Backing Pads.....	921, 925, 935
Box Sealing Tape.....	1410-1411, 1429
Bristle Brushes.....	921, 1271
Bristle Discs.....	921
Burnishing Pads.....	362
Butterfly Wound Closures.....	742
Compresses.....	746
Conspicuity Tape.....	850
Contact Cement.....	1029
Cut & Polish Wheels.....	938
Cut-Off Wheels.....	912, 916
Deburring Wheels.....	936, 938, 1271
Degreasers, Heavy-Duty.....	319, 1005, 1036
Disc Holder Pads.....	923, 925, 927, 935-936, 938
Display Hangers, Merchandise.....	1435
Disposable Respirators.....	448-449
Document Laminators.....	1574
Double Sided Tape.....	1416
Duct Tape.....	1415
Dust Mask Dispensers.....	453
Ear Plugs	
Dispensers.....	427
Disposable.....	425
Fabric Bandages.....	741
Faceshields.....	412
Filament Tape.....	1412
Filter Plates.....	1126
Finishing Wheels.....	938
Flap Brushes.....	937
Flap Discs.....	918
Flap Wheels.....	919, 937
Full Face Respirators.....	455
Glasses	
Reading.....	399
Safety.....	399-401
Glue, Sticks.....	1418
Glue Guns.....	1418
Goggles, Safety.....	406
Grinding Wheels, Type 27.....	915
Half Mask Respirators.....	454-455
Hand Pad Holders.....	933-934, 938
Hand Scrubbers.....	302
Helmets, Welding.....	1126-1127
Magnifier Plates.....	1126
Masking Tape.....	1414
Packing List Envelopes.....	1449
Pads, Cleaning.....	292, 362
PAPR Respirators.....	466, 471-473, 475, 477, 479, 481, 1127
Penetrants, 5-Way.....	1013
Plastic Bandages.....	741
Polyethylene Foam Tape.....	1416
Positive Pressure Respirators.....	466, 477
Power-Lock Discs.....	925, 935
Resin Fibre Discs.....	923, 925
Respirators	
Cartridges.....	456, 466, 472-473, 475, 477
Filters.....	456-457, 475
Fit Test Kits.....	465
Headgear.....	473, 479, 1127
Sanding Sponges.....	933
Sandpaper.....	930, 932
Scouring Pads.....	302, 320, 362
Self-Stick Bandages.....	742, 746
Sheathing Tape.....	1437
Sound Level Meters, Integral Probe.....	440, 1480
Spray Adhesives.....	1036, 1418
Spray Lubricants.....	1008
Stethoscopes.....	756
Stick-On Discs.....	927
Stripping Pads.....	362
Supplied Air Respirators.....	466, 479
Surface Conditioning Belts.....	937
Surface Conditioning Discs.....	934-936, 938
Surface Conditioning Pads.....	302, 933

Surface Conditioning Rolls.....	930, 933-934
Tape	
Electrical.....	1417, 1544
First Aid.....	744
Office.....	1580
Tape Dispensers	
Filament Tape.....	1411
Gummed Tape.....	1411
Two-Way Tape.....	1416
Vinyl Tape.....	1416
Wipes.....	465

ACCENT HOME

Small Parts Cabinets.....	33
---------------------------	----

ACCUFORM SIGNS

Accident Prevention Tags.....	786-788, 790
Admittance Signs.....	803-810, 813
Blank Tags.....	791-792
Cable Ties.....	793
Chemical Hazard Signs.....	804, 808
Confined Space Signs.....	804, 808
CSA Standard Signs.....	814-817
Direction Signs.....	811
Ear Protection Signs.....	806, 809
Electrical Hazard Signs.....	804-805, 808
Exit Signs.....	807, 810
Eye Protection Signs.....	806, 809
Fall Protection, Signs.....	806
Fire Protection, Signs.....	653, 807, 810, 812, 817, 822
First Aid, Signs.....	727, 805, 809, 812
Floor Signs.....	813
GHS	
Information Centres.....	848
Information Charts.....	847
Safety Labels.....	844-845
Wallet Card.....	844
Hazardous Materials Signs.....	808
ISO Safety Labels.....	818-819, 845
Machinery & Operations Signs.....	804-805, 809
Maintenance Signs.....	808-809, 813
MSDS	
Binders.....	849
Information Centers.....	848-849
No Smoking Signs.....	806-808, 810
Parking Signs.....	810
Pipe Markers.....	833-841
Protective Wear Signs.....	806, 809
Safety Signs.....	727, 806, 809, 849
Scoreboard Signs.....	822-823
SDS	
Binders.....	849
Information Centre.....	848-849
Poster.....	847
Self-Adhesive Letters.....	800
Self-Adhesive Numbers.....	800
Shipping & Receiving Signs.....	813
Tags, Lockout.....	786-788, 790
Traffic Signs.....	210, 807, 810, 812, 820-821, 851
Washroom Sign.....	813
Wheel Locks.....	782
WHMIS	
Information Charts.....	847
Labels.....	846
Pictograms.....	845-846
Posters.....	847

AIGNER INDEX

Aisle Signs.....	12, 48
Label Holders.....	5, 12, 48, 72-73
Label Makers, Accessories.....	5, 12
Magnetic Tags.....	12

AIR MASTER

Ceiling Fans.....	1498
Drum Fans.....	1497, 1502

Exhaust Fans.....	1501
Pedestal Fans.....	1497-1499
Wall Mounted Fans.....	1497-1498

AIRFLOW

Integral Probe Anemometers.....	1486
---------------------------------	------

AKRO-MILS

Small Parts Cabinets.....	34
Stacking Bins.....	5

ALB PLUS

Cabinets, Storage.....	97-98, 1561, 1563
Dollies, Steel Deck.....	97, 103
Lockers, Steel.....	104

ALDON

Rail Chocks.....	210
Wheel Chocks.....	210

ALEMITE

Grease Guns.....	997
Grease Pumps.....	999
Pipe Fittings, Lubrication.....	999, 1001

ALGOOD

Casters.....	229-230
Wheels.....	232-233

ALLEGRO INDUSTRIES

Axial Blowers.....	488-489
Centrifugal Blowers.....	489
Fan Guards.....	489
Guard Rails.....	489
Knee Pads, Leather.....	1133
Manhole Lid Lifters.....	489
Manhole Shields.....	489
Portable Blowers.....	488
Tent Heaters.....	489
Work Tents.....	489

ALLEN INDUSTRIAL HAND TOOLS

Hex Keys.....	1346-1347
---------------	-----------

ALLIANCE PLASTICS

Poly Tubing.....	1430
------------------	------

ALLPAX

Rubber Cutting Knives.....	1371
----------------------------	------

ALL-VAC INDUSTRIES

Magnetic Lifters.....	196
Vacuum Cups.....	196-197

ALNOR

Balometers.....	1488
Temperature Probes.....	1488

ALTE-REGO

Bags, Laundry.....	303
Construction, Vapor Barriers.....	1437
Garbage Bags.....	278, 281-282, 383, 761
Gaylord Liners.....	280
Liners, Container.....	280
Pallet Covers.....	1423
Poly Tubing.....	1437

BRAND INDEX

Seat Cover, Automotive.....	280
Tire Bags.....	280

AMANO CINCINNATI

Time Clocks.....	1575
------------------	------

AMERICAN WATER BROOM

Water Brooms.....	377
-------------------	-----

AMPCO

Ball Pein Hammers, Non-Sparking.....	1380
Cabinet Tip Screwdrivers.....	1383
Cross-Point Screwdrivers.....	1383, 1386
Crowbars, Non-Sparking.....	1380
Curved Blade Knives.....	1382, 1386
Curved Claw Hammers.....	1380
Diagonal Cutters.....	1383
Flat Tip Screwdrivers.....	1383, 1386
Hammers, Non-Sparking.....	1380, 1386
Hand Chisels.....	1381
Hand Scrapers, Non-Sparking.....	1382, 1386
Hex Keys, Non-Sparking.....	1383
Linoleum Knives.....	1382
Maintenance Brushes.....	1383, 1386
Mallets.....	1380
Non-Sparking Tool Kits.....	1386
Non-Sparking Tools	
Pliers.....	1383, 1386
Wedge.....	1381
Wrenches.....	1384-1386
Picks.....	1381
Pinch Bars.....	1380
Pry Bars	
Crate Openers.....	1380, 1386
Nail Pullers.....	1380
Non-Sparking.....	1380
Putty Knives	
Flexible.....	1382
Stiff.....	1382, 1386
Round Point Shovels.....	1381
Scoop Shovels.....	1381
Scrapers, Drywall.....	1382
Screwdrivers, Sets.....	1383
Sledge Hammers, Non-Sparking.....	1380
Sockets, Non-Sparking.....	1385
Spatulas, Non-Sparking.....	1382
Square Point Shovels.....	1381
Straight Blade Knives.....	1382, 1386
Utility Knives.....	1382

AMPROBE

Cable Tracers.....	1468, 1543
--------------------	------------

ANSELL

Chemical Resistant Gloves.....	583, 586-589
Coated Gloves.....	562-577, 580, 591
Cut Resistant Gloves.....	575-578, 580
Disposable Gloves.....	594, 598-599
Gloves, Holders.....	593
Winter Lined Gloves.....	571, 593, 626

ANTHONY STEEL MFG.

Cabinets, Storage.....	97
Gas Cylinder, Lockouts.....	106
Lockers, Steel.....	106

APEX

Bit Holders.....	1343
Cross-Point Bits.....	1345
Hex Bits.....	1344
Hex Square Drive Bits.....	1343
Nutsetters.....	1343

Posidriv® Bits.....	1345
Slotted Bits.....	1344-1345
Square Recess Bits.....	1344-1345
Torque Bits.....	1343
Torx® Bits.....	1343-1344
Tri-Wing Bits.....	1344

ARMSTRONG TOOLS

Adjustable Wrenches.....	1330
Aligning Punches.....	1369
Angle Wrenches.....	1335
Ball Pein Hammers, Fiberglass Handle.....	1365
Box Wrenches	
15 Degree Offset.....	1336
25 Degree Offset.....	1336
45 Degree Offset.....	1336
Geared.....	1331
Brass Hammers.....	1365
Cape Chisels.....	1368
C-Clamps.....	1289
Center Punches.....	1368
Chain Nose Pliers.....	1348
Chisel Holders.....	1367
Cold Chisels.....	1367-1368
Combination Wrenches.....	1331
Sets.....	1337
Convertible Pliers.....	1353
Copper Hammers.....	1365
Dead Blow Hammers.....	1363
Diagonal Cutters.....	1348
Drift Punches.....	1369
Flare Nut Wrenches.....	1335-1336
Flex Head Wrenches.....	1335
Gear Wrenches, Sets.....	1337
Hex Bit Sockets.....	1315-1316
Impact Sockets.....	1323-1325, 1327
Lineman's Pliers.....	1348
Mallets.....	1363
Needle Nose Pliers.....	1349
Nut Drivers	
Hollow Shaft.....	1342
Sets.....	1342
Open End Wrenches.....	1335
Pin Punches.....	1369
Pinch Bars.....	1367
Power Sockets.....	1323, 1327
Pry Bars	
Rolling Head.....	1367
with Handle.....	1367
Pump Wrenches.....	1335
Ratchets	
1 1/2" Drive.....	1324
1" Drive.....	1324
1/2" Drive.....	1315, 1321
1/4" Drive.....	1324
3/4" Drive.....	1322
3/8" Drive.....	1316, 1319
Retaining Ring Pliers.....	1353
Rolling Head Bars.....	1367
Slip Joint Pliers.....	1348
Socket Accessories.....	1314-1316, 1319, 1321-1324, 1327
Socket Sets, Standard.....	1314-1315
Sockets, Standard.....	1314-1316, 1319, 1321-1322
Soft Face Hammers.....	1363
Spanner Wrenches.....	1330
Starting Punches.....	1370
Striking Face Wrenches.....	1331
Structural Wrenches.....	1330
Tongue & Groove Pliers.....	1348
Torque Meters.....	1329
Torque Multipliers.....	1328
Torque Wrenches.....	1328

ARROW

Carton Staplers.....	1446-1447
Nail Guns, Electric.....	1446
Nails, for Nail Guns.....	1446

Staples

Carton Staplers.....	1446-1447
Pneumatic Stapler.....	1447

ATLAS GRAHAM

Angled Brooms.....	290
Boot Covers.....	289, 889
Buckets.....	305
Corn Brooms.....	289-290
Dusters, Janitorial.....	302
Dustpans.....	290
Extension Poles.....	287-288, 293, 297-298, 302
Floor Scrapers.....	298
Frames, Dust Mop.....	293, 302
Litter Scoops.....	290
Maintenance Brushes.....	26, 300-301
Microfiber Cloths.....	293
Mops	
Dust.....	293, 295
Wet.....	292-293, 295, 304-306
Pads, Cleaning.....	292
Pot Brushes.....	26, 301
Push Brooms.....	287-290, 301
Scouring Pads.....	292
Scrub Brushes.....	26, 291, 300
Shelf Carts.....	168
Shoe Covers.....	289, 889
Squeegees.....	297-299, 301
Switch Brooms.....	290
Toilet Bowl Brushes.....	349
Vehicle Brushes.....	292
Whitewash Brushes.....	292
Window Brushes.....	292

ATLAS WELDING ACCESSORIES

Chipping Hammers, Welding.....	1087-1088
--------------------------------	-----------

ATRIX

Vacuums	
Accessories.....	361
Wet / Dry.....	361

AURORA TOOLS

Adjustable Wrenches.....	1309-1312, 1332
Angle Grinders, Air.....	1204
Ball Pein Hammers, Wood Handle.....	1309-1310, 1312, 1362, 1365
Bench Vises.....	1293
Blades, Packaging Knife.....	1440
Bolt Cutters.....	1360
Booster Cables.....	1542
Broadcast Spreaders.....	364, 370
Cabinet Tip Screwdrivers.....	1309-1312, 1338
Cable Ties.....	1452
Calipers, Digital.....	1275, 1309-1310
Carton Staplers.....	1446
Caulking Guns.....	1024
C-Clamps.....	1288
Center Punches.....	1309-1310, 1312, 1368, 1370
Chippers, Air.....	1088, 1207
Claw Hammers.....	1362
Club Hammers.....	369, 1365
Cold Chisels.....	1309-1310, 1312, 1367, 1370
Combination Wrenches.....	1332
Sets.....	1309-1310, 1312, 1332
Control Valves.....	1000
Cord Reels, Extension Cords.....	1537
Cross-Point Screwdrivers.....	1309-1312, 1338
Curved Claw Hammers.....	1309-1312, 1364
Cut-Off Tools, Air.....	1204
Dead Blow Hammers.....	1309-1312, 1362-1363
Diagonal Cutters.....	1309-1312, 1348, 1353
Die Grinders, Air.....	1204
Drain Spades.....	366
Drift Punches.....	1309-1310, 1369-1370
Drills, Air.....	1205

Extension Cords

Single Outlet.....	1535-1537
Triple Outlet.....	1535, 1537

Flashlights

AA Cell.....	1517
AAA Cell.....	1517
D Cell.....	1517
Mini.....	1517

Flat Tip Screwdrivers.....

	1309-1312, 1338
--	-----------------

Floodlights.....

	1528
--	------

Funnels, Clean.....

	.994
--	------

Garden Spades.....

	.366
--	------

Glue, Sticks.....

	1036, 1418
--	------------

Glue Guns.....

	1036, 1418
--	------------

Grease Guns.....

	996, 1017, 1309
--	-----------------

Grease Pumps.....

	1000
--	------

Guns, Air.....

	1226, 1230
--	------------

Hacksaws, Frames.....

	1301, 1309-1312
--	-----------------

Halogen Lamps / Light Bulbs.....

	1528
--	------

Hand Lamps.....

	1525
--	------

Hand Stamps.....

	795, 1117
--	-----------

Headlights, Hard Hat.....

	.419
--	------

Hex Keys.....

	1309-1312, 1346-1347
--	----------------------

Hold-Down Clamps.....

	1290
--	------

Hose Reels.....

	1076, 1236-1237
--	-----------------

Hoses

Air.....	1207, 1233
----------	------------

Lubricant.....	.996
----------------	------

Impact Wrenches, Air.....

	1205
--	------

Knives, Packaging.....

	1309, 1312, 1440
--	------------------

Latch Clamps.....

	1290
--	------

Lineman's Pliers.....

	1309-1312, 1348
--	-----------------

Locking Pliers.....

	1288, 1309-1312, 1352, 1354
--	-----------------------------

Long Nose Pliers.....

	1309-1312, 1348
--	-----------------

Mallets.....

	1309, 1311, 1362-1363
--	-----------------------

Measuring Cups.....

	.994
--	------

Measuring Tape, Retractable Blade.....

	1277, 1309-1312
--	-----------------

Micrometers, Digital.....

	1275
--	------

Multi-Purpose Hand Tools.....

	1355
--	------

Nose Cutting Pliers.....

	1353
--	------

Oil Cans.....

	.999
--	------

Orbital Sanders, Air.....

	1207
--	------

Paint Supplies, Brushes.....

	1047
--	------

Parallel Clamps.....

	1287
--	------

Pin Punches.....

	1309-1310, 1312, 1368, 1370
--	-----------------------------

Pipe Fittings, Lubrication.....

	1000
--	------

Power Strips, GFCI.....

	1541
--	------

Pry Bars, Multi-Purpose.....

	1309-1312, 1366
--	-----------------

Quick Couplers.....

	1207, 1233
--	------------

Rakes.....

	.367
--	------

Ratchet Wrenches, Air.....

	1206
--	------

Ratchets

1/2" Drive.....	1317-1318, 1320
-----------------	-----------------

1/4" Drive.....	1317
-----------------	------

3/8" Drive.....	1318
-----------------	------

Round Point Shovels.....

	.366
--	------

Scalers, Air.....

	1207
--	------

Scaling Chisels.....

	1088
--	------

Screwdrivers

Air.....	1207
----------	------

Sets.....	1338
-----------	------

Sealing Spatula.....

	1052
--	------

Sets, Pliers.....

	1354
--	------

Sledge Hammers, Non-Sparking.....

	369, 1365
--	-----------

Slip Joint Pliers.....

	1309-1312, 1348
--	-----------------

Small Parts Cases.....

	.36
--	-----

Snow Shovels.....

	.365
--	------

Socket Accessories.....

	1317-1318, 1320
--	-----------------

Socket Sets, Standard.....

	1309-1310, 1312-1314
--	----------------------

Sockets, Standard.....

	1317-1318, 1320
--	-----------------

Sprayers, Lawn & Garden.....

	320, 371
--	----------

Square Point Shovels.....

	.366, 368
--	-----------

Square Screwdrivers.....

	1309-1312, 1338
--	-----------------

Staples, Office Staplers.....

	1446
--	------

Straight Line Clamps.....

	1290
--	------

Surface Conditioning Pads.....

	.933
--	------

Technicians' Tools.....

	1309-1312
--	-----------

Telescopic Lights.....

	1528
--	------

Toggle Clamps.....

	1290
--	------

Tongue & Groove Pliers.....

	1309-1312, 1348
--	-----------------

Tool Storage

Boxes.....	1309-1311, 1394
------------	-----------------

Cabinets.....	1309, 1312, 1395
---------------	------------------

Carts.....	1395
------------	------

Chests.....	1309-1310, 1394-1395
-------------	----------------------

Jobsite Boxes.....	36, 1394
--------------------	----------

Tree Trimmers.....

	369
--	-----

Trigger Sprayers.....

	302, 320
--	----------

Utility Knives.....

	1440
--	------

Vacuums

Accessories.....	352-353
------------------	---------

Wet / Dry.....	352-353
----------------	---------

Wrecking Bars.....

	1366
--	------

Wrenches, Pipe.....

	1309, 1373
--	------------

AVERY DENNISON

Cable Ties.....	.794, 1452
-----------------	------------

AVMOR

Drain Cleaners.....	316
---------------------	-----

AYLING & REICHERT

Pumps, Drum.....	255
------------------	-----

BACHARACH

Combustible Gas Detectors.....	.487
--------------------------------	------

BAFFIN TECHNOLOGY

Knee Boots.....	632
-----------------	-----

Winter Boots.....	.635-636
-------------------	----------

BALDOR

Bench Grinders.....	1270
---------------------	------

BASCO

Scoops, Aluminum.....	.994
-----------------------	------

BATTERY EQUALISER

Battery Equalizers.....	1037
-------------------------	------

BEGHELLI

Batteries	
-----------	--

12 Volt.....	1522
--------------	------

6 Volt.....	1522
-------------	------

Emergency Lights.....	1521-1522
-----------------------	-----------

Exit Lights.....	1521
------------------	------

BELLE-PAK

Packing List Envelopes.....	1449
-----------------------------	------

BEN-MOR

Aircraft Cables.....	194
----------------------	-----

Clevis Grab Hooks.....	192
------------------------	-----

Eye Bolts.....	194
----------------	-----

Lifters, Drum.....	243
--------------------	-----

Slings

Chain.....	189
------------	-----

Polyester.....	188-189
----------------	---------

Slip Hooks.....	192
-----------------	-----

BERNARD

Contact Tips, MIG Gun.....	1094, 1098
----------------------------	------------

Diffusers, MIG Gun.....	1098
-------------------------	------

Electrode Holders.....	1084
------------------------	------

Insulator Caps, MIG Gun.....	1098
------------------------------	------

Nozzles, MIG Gun.....	1098
-----------------------	------

BERNZOMATIC

Butane Torches.....	1083
---------------------	------

BESSEY

Angle Clamps.....	1285
-------------------	------

Bar Clamps.....	1284-1286
-----------------	-----------

Bench Vises.....	1293
------------------	------

Edge-Gluing Clamps.....	1288
-------------------------	------

Hold-Down Clamps.....	1290
-----------------------	------

L-Clamps.....	1284
---------------	------

Parallel Clamps.....	1286
----------------------	------

BRAND INDEX

Eyewash Stations	
Faucet Mounted.....	720
Pedestal Mounted.....	717
Self Contained.....	722-723
Sink Mounted.....	720
Wall Mounted.....	716, 720
Lockers, Plastic	109
Privacy Shower Curtain	727
Shower Testers	726
Soap Dispensers	326
Thermostatic Mixing Valves	721

BRADY

Aisle Marking Tape	869
Ball Valve Lockouts	783
Barricade Tape	868
Disposable Dust Masks	453
Ear Plugs, Dispensers	431
Exit Signs	811
Flagging Tape	869
Glasses, Safety	407
Gloves, Dispensers	600
Glow in the Dark Tape	811
Label Makers	
Accessories.....	825, 827-828
Portable.....	824-825, 827
Ribbons.....	824-828, 830
Table Top Versions.....	828
Tapes.....	825-826, 828-830
Lockouts	
Kits.....	777
Stations.....	772
Vinyl Tape	829
WHMIS	
Labels.....	846
Wallet Cards.....	846

BRK ELECTRONICS

Fire Protection, Fire Alarm Protectors	655
---	-----

BROTHER

Label Makers	
Portable.....	1572-1573
Ribbons.....	1573
Table Top Versions.....	1572-1573
Tapes.....	1572-1573

BUCAN

Heaters	
Drum.....	237
Pail.....	237

BULMAN

Paper Cutters	1432
----------------------	------

BULWARK

Arc Flash Clothing	
Coveralls.....	554-555
Jackets.....	555
Overalls.....	555
Pants.....	554
Shirts.....	554
Coveralls, Work	554
Parkas	555

BW TECHNOLOGIES BY HONEYWELL

Docking Stations	482-483
Gas Detectors	
Calibration Gas.....	484
Sensor.....	484
Multi-Gas Detectors	482-484

Regulator, Calibration Gas	484
Single-Gas Detectors	482

C.H. HANSON

Barricade Tape	868
Beaded Chain	794
Blank Tags	793
Chain, Crowd Control	794
Flagging Tape	869
Hand Stamps	795-796
Ink Stencils	797
Key Rings	794
Locking Pliers	1352
Marking Flags	871
Numbered Tags	793
Paint Stencils	798
Seals	
Sealing Press.....	794
Security.....	794

C.R. DANIELS INC.

Hampers	303
Ironer Trucks	303
Linen Trucks	303

CALDWELL

Lifters, Drum	238
----------------------	-----

CAMFIL FARR

Air Filters	1506
--------------------	------

CAMPBELL

Clamps, Lifting	198
Clevis Grab Hooks	192
Hooks, Lifting	192

CANABLAST

Dust Collectors, Sandblasting	1056
Guns, Sandblasting	1057
Media, Sandblasting	1055
Media Recyclers, Sandblasting	1056
Portable Blasters, Sandblasting	1057
Suction Cabinets	1056-1057

CANADIAN MAILBOX COMPANY

Mailboxes	1576
------------------	------

CANARM

Smoke Ejectors	1501
-----------------------	------

CANON

Paper, Printer & Photocopier	1579
---	------

CAP CANADA DISTRIBUTION INC.

Absorbents	684
-------------------	-----

CARDINAL CORRUGATED CONTAINERS

Small Parts Bins, Fiberboard	11
-------------------------------------	----

CARGOLOC

Bungee Cords	1455
Cargo Nets	1455
Tie-Downs	1455-1456

CASCADES

Facial Tissue	344
Hand Towels	340-342, 344, 1583
Napkin Dispensers	343-344, 1583
Napkins, Cafeteria	343-344, 1583
Paper Towel Dispensers	340-342, 1583
Paper Towels	344
Toilet Paper	340, 345-346
Toilet Paper Dispensers	345, 347
Wipes	336, 384
Wipes Dispensers	336, 340

CAULK MASTER

Caulking Guns	1024
----------------------	------

CCI CANADA

Channelizers, Traffic Control	864
Cones	
Safety.....	308
Traffic Control.....	862
Delineators, Traffic Control	863-864
Flashing Lights	866

CENTENNIAL

Racks, Drum	245
--------------------	-----

CERTAINTY WIPES

Wipes Dispensers	334
-------------------------	-----

CHAPIN

Sprayers, Lawn & Garden	320, 371-372
------------------------------------	--------------

CHECKERS INDUSTRIAL PRODUCTS

Cable Protectors, Dock	217
Wheel Chocks	211

CHEMETALL

Non-Aqueous Developers	1144
Non-Chlorinated Degreasers	1144
Penetrants, Water Based	1144

CHEMOTEC

Dish Detergents	316
Floor Cleaners	310
Floor Finishes	311
Floor Sealers	311
Floor Stripper	311
Hand Cleaners, Lotion	326
Oven Cleaners	316
Stainless Steel Cleaners	316
Toilet Bowl Cleaners	314

CHICAGO PNEUMATIC

Angle Grinders, Air	1211, 1215
Automotive Stands	207
Belt Sanders, Air	1213
Bottle Jacks	206
Chippers, Air	1213
Die Grinders, Air	1212, 1215
Drills, Air	1209
Engravers, Air	1212
Garage Jacks	206
Hammers, Air	1213
Impact Wrenches, Air	1208, 1210, 1214
In-Line Drills, Air	1209
Mini Die Grinders, Air	1215
Orbital Sanders, Air	1211-1212
Ratchet Wrenches, Air	1210
Reciprocating Saws, Air	1214
Rotary Sanders, Air	1211

Scalers, Air.....	1214
Screwdrivers, Air.....	1209, 1211
Shears, Air.....	1214

CI CALSTONE INC.

Bench Scales.....	1433
Casters.....	1433
Packaging, Benches.....	1433
Paper Cutters.....	1427, 1432-1433
Shipping, Benches.....	1433

CIMCO

Combination Slip-Joint Pliers.....	1377
Hex Wrenches.....	1378
Insulated Cutters.....	1377
Snipe Nose Pliers.....	1377
Technicians' Tools.....	1378-1379

CIMCOOL

Tapping Compounds.....	1149
------------------------	------

CK WORLDWIDE INC

Air (Gas) Cooled Torches.....	1101, 1103-1104
Alumina Nozzles.....	1106
Back Caps, TIG Torch.....	1108
Collet Bodies, TIG Torch.....	1107-1109
Collets, TIG Torch.....	1107
Fuse Blocks, TIG Torch.....	1110
Gas Hoses, Welding.....	1110
Lava Nozzles.....	1105
Power Cable Adapters, TIG Torch.....	1109
Power Cables, TIG Torch.....	1110
TIG Welders.....	1113
Torch Kits, Welding.....	1109
Tungsten Electrode Grinders.....	1113-1114
Tungsten Electrodes.....	1114
Water Cooled Torches.....	1103-1104
Water Hoses, Welding.....	1110

CLARKSON OSBORN

Adjustable Reamers.....	985
Annular Cutters.....	972, 1193
Burs, Carbide.....	990-991, 1215
Chucking Reamers	
Cobalt.....	985
HSS.....	981-985
Circular Split Dies.....	978, 980
Dies, Die Stocks.....	977
Drill Bits	
Aircraft Extension.....	968, 972
Jobber.....	963-967
Spiral Flute.....	972
Straight Shank.....	971
Taper Length.....	969
Taper Shank.....	971
End Mills	
Carbide.....	988-989
HSCo.....	986-987
HSS.....	986
Weldon Shank.....	986
Hand Reamers.....	981
Hand Taps.....	974-975, 977, 988
Hexagonal Dies.....	978-979
Machine Taps.....	976
Pipe Taps.....	973
Prentice Drill Bits.....	969-970
Screw Extractors.....	989
Tap & Drill Sets.....	973
Tap Wrenches.....	977
Taper Pin Reamers.....	982
Tool Holders, Turning Tools.....	986

CLECO

Impact Wrenches, Air.....	1222
In-Line Drills, Air.....	1221
Screwdrivers, Air.....	1222

CLOROX

Wipes.....	318, 759
------------	----------

CM INDUSTRIES

Beam Clamps.....	199
Beam Trolleys.....	190
Hoists	
Air.....	191
Electric.....	191
Manual.....	190-191

COGAN

Guard Rails.....	84
------------------	----

COLSON

Casters.....	230-231
Floor Lock Brakes.....	231

CONTOUR

Burning Guides.....	1117
Pipe Contour Markers.....	1116-1117
Pipe Flange Aligners.....	1116
Pipefitting Levels.....	1116-1117

COOLWORKS

High Visibility Clothing, Pants.....	551
--------------------------------------	-----

COOPER INDUSTRIES INC

Plugs, Electrical.....	1084
Receptacles, Electrical.....	1084

CORDEX

Buckles	
Plastic.....	1421-1422
Poly.....	1422
Steel.....	1421
Seals, Steel.....	1421
Strapping	
Dispensers.....	1422
Machines & Tools.....	1419
Poly.....	1422

CORNER EDGE

Edge Protectors.....	48, 1423
----------------------	----------

CRAMER

Stepladders.....	135
------------------	-----

CRC CANADA

Air Tool Oil.....	1261
Automotive Cleaners, Diesel Conditioner.....	1015
Battery Cleaners.....	1015
Brake Cleaners.....	1015
Carburetor Cleaner.....	1015
Contact Cleaners.....	1006
Degreasers, Heavy-Duty.....	1002-1003, 1005
De-Icer.....	1015
Dry Lubricants, Graphite.....	1008
Food Grade Degreasers.....	1003
Freeze Spray.....	1006
Lubricants, General Purpose.....	1013
Paint, Rubber.....	1015
Parts Washers.....	995

Rust Converters.....	1014
Spray Lubricants.....	1008

CRESCENT

Adjustable Wrenches.....	1332
Pry Bars, Multi-Purpose.....	1366

CREWS

Faceshields.....	412
------------------	-----

CROSBY

Beam Clamps.....	199
Clamps, Lifting.....	198

CROWN-MEAKINS

Paint Supplies	
Brushes.....	1047-1049
Roller Covers.....	1049-1051
Rollers.....	1051
Sponging & Ragging.....	1050

DAINOLITE LTD

Desk Lamps.....	1524, 1582
Fluorescent Lamps / Light Bulbs.....	1524, 1582
Halogen Lamps / Light Bulbs.....	1524, 1582
Incandescent Lamps / Light Bulbs.....	1582
Magnifiers	
Illuminated.....	1524
Lenses.....	1524
Wall Clocks.....	1575

DAKOTA

Thickness Gauges.....	1479
-----------------------	------

DANBY

Refrigerators.....	1584
--------------------	------

DBI SALA

Anchorage Connectors.....	517
Beam Clamp Anchors.....	517
Carabiners.....	516
Davits.....	490
D-Bolt Anchors.....	516
D-Ring Harnesses.....	495
Fall Protection, Harnesses.....	141, 494-495
Friction Bolt Anchors.....	516
Hard Hat Lanyards.....	524
Positioning and Restraint Lanyards.....	508
Rescue Systems.....	491-492, 496, 518
Rope Grabs.....	517-518
Self-Retracting Lanyards.....	492, 512
Self-Retracting Life Lines.....	492, 512, 518
Shock Absorbing Lanyards.....	141, 507
Tool Lanyards.....	524
Vertical Life Lines.....	517
Winches, Personal.....	492

DEB STOKO

Hand Cleaners, Lotion.....	332
Hand Creams.....	331
Hand Sanitizers.....	333
Shampoo.....	325
Skin Conditioners.....	333
Soap Dispensers.....	331-332
Sunscreen.....	335
Wipes.....	334

DECADE

Back Supports.....	642
--------------------	-----

BRAND INDEX

DEFELSKO

Porosity Detectors.....	1478
Thickness Gauges.....	1478

DEFENDER

Task Lights.....	1529
------------------	------

DELMHORST INSTRUMENT CO.

Moisture Meters.....	1477
----------------------	------

DENTEC

Eyewash Stations	
Bottled.....	724
Water Preservatives.....	722
Foot Warmers.....	636
Hand Warmers.....	629

DE-STA-CO

Hold-Down Clamps.....	1291-1292
Latch Clamps.....	1291-1292
Straight Line Clamps.....	1292
Toggle Clamps.....	1291

DEWALT

Angle Drills, Electric.....	1184
Angle Grinders, Electric.....	1168-1171
Bandsaws, Wood Cutting.....	1178
Battery Chargers.....	1167
Bench Grinders.....	1270
Caulking Guns.....	1161
Chop Saws.....	1174
Circular Saws, Heavy-Duty.....	1177
Combo Kits.....	1164-1166
Compressors, Air.....	1262
Cordless Power Tool Batteries.....	1157-1158, 1160-1161, 1164, 1167
D Handle Drills.....	1183
Demolition Hammers.....	1187
Die Grinders, Electric.....	1172
Drills	
Drill / Drivers.....	1182
Drill / Drivers - Cordless.....	1157, 1161
Hammer Drill / Drivers.....	1158
Hammer Drills.....	1184-1185
Hand Powered Drills.....	1182-1183
Impact Wrenches	
Cordless.....	1160
Electric.....	1181
Jig Saws, Heavy-Duty.....	1178
Laser Levels.....	1283
Mitre Saws.....	1175-1176
Nail Guns, Cordless.....	1163
Palm Sanders.....	1180
Plumb Bobs.....	1283
Reciprocating Saws, Electric.....	1179
Rotary Hammers.....	1185-1186
Screw Guns.....	1187
Shears, Power.....	1173

DIMAR

Circular Saw Blades.....	1203
Combination Saw Blades.....	1203
Cut-Off Blades.....	1203
Forstner Bits.....	1200
Mitre Saw Blades.....	1203

DIVERSIFIED PLASTICS INC.

Column Protectors.....	86
Stepstools, Polyethylene.....	136

DORMER

Combined Drills & Countersinks.....	961
Countersinks.....	962
Drill Bits, Jobber.....	948, 952
Hand Taps.....	957-960
Pipe Taps.....	960

DOTCO

Angle Drills, Air.....	1222
Angle Grinders, Air.....	1222
Die Grinders, Air.....	1223
Drills, Air.....	1223
Engravers, Air.....	1223
Pencil Grinders, Air.....	1223

DREMEL

Dremel Tools.....	1192
-------------------	------

DUPONT PERSONAL PROTECTION

Aprons, General Protection.....	534
Boot Covers.....	534
Coveralls	
General Protection.....	535-537
Limited Use.....	537
Hoods, General Protection.....	534
Lab Coats, General Protection.....	534, 536
Pants, General Protection.....	534
Shirts, General Protection.....	534
Sleeves, Polypropylene.....	534

DURATRACK

Strip Curtain Doors.....	91, 93
--------------------------	--------

DURHAM MANUFACTURING

Cabinet Drawers.....	37
Literature Displays.....	1568
Mail Sorters.....	1566
Parts Storage Carts.....	42
Revolving Bins.....	29
Small Parts Cabinets.....	33, 37, 42-43, 45
Small Parts Cases.....	36
Threaded Rod Racks.....	45
Wire Spool Carts.....	167
Workbenches.....	125

DUSTBANE

Carpet Cleaners.....	317
Degreasers, Heavy-Duty.....	313
Dilution Dispenser.....	313
Disinfectants.....	313, 318, 759
Environmental Cleaners.....	317-318
Floor Cleaners.....	311
Floor Finishes.....	362
Floor Sealers.....	362
Floor Stripper.....	362
Glass Cleaners.....	315
Hand Cleaners, Lotion.....	315
Industrial Cleaners, Multi-Purpose.....	313-314
Machine Cleaners, Heavy-Duty.....	320
Solvent Free Degreasers.....	313
Sweeping Compounds.....	290
Vacuums, Wet / Dry.....	360

DWYER

Ball Valves.....	1231
Butterfly Valves.....	1231
Manometers.....	1488

DYKEM

Paint Markers.....	1442
Tamper Proof Torque Mark.....	1342

DYMO

Label Makers	
Portable.....	1574
Software.....	1574
Tapes.....	1574

DYNABRADE

Belt Sanders, Air.....	1216-1217, 1220-1221
Buffers, Air.....	1221
Die Grinders, Air.....	1220
Orbital Sanders, Air.....	1218-1219
Swivel Connectors.....	1219, 1250

DYNAFLUX QUALITY PRODUCTS

Aluminum Cleaners.....	1145
Anti-Spatter.....	1145
Galvanizing Compounds.....	1144
Layout Fluids.....	1145
Nozzle Gels, MIG Gun.....	1145
Pump Lubricants.....	1144
Tungsten Electrode Grinders.....	1114

DYNALINE

Funnels, Polyethylene.....	317, 994
----------------------------	----------

EAGLE MFG.

Column Protectors.....	86
Edge Protectors.....	86, 216

E-A-R

Ear Plugs	
Corded.....	426
Dispensers.....	427
Disposable.....	424-427
Reusable.....	428-429
Uncorded.....	426
Hearing Bands.....	430-431

ECHO

Sprayers, Lawn & Garden.....	371
------------------------------	-----

EDGE SAFETY EYEWEAR

Glasses	
Cases.....	407
Safety.....	402-403

EDSAL

Bookcases.....	1567
Cabinet Tables.....	124
Cabinets, Storage.....	98, 103, 1561
Computer Cabinets.....	1559-1560
Filing Cabinets, Lateral.....	1563
Service Writers.....	126
Shelving Units	
Chrome.....	56
Steel.....	55-56, 58
Shop Desks.....	126
Tool Storage	
Cabinets.....	103
Carts.....	124
Workbenches.....	120, 125

ELMER'S

Carpenters' Glue.....	1029
Construction Adhesives.....	1029
Contact Cement.....	1029
Pencil Sharpeners.....	1578
White Glue.....	1029
Wood Glue.....	1029

ELWOOD PACKAGING

Boxes, Mailers	1434
Cones, Pallet	48, 1423

ENERGIZER

Batteries	
1.5 Volt.....	1507
12 Volt.....	1507
3 Volt.....	1507
6 Volt.....	1507
9 Volt.....	1507
AA Cell.....	1507,
AAA Cell.....	1507,
C Cell.....	1507,
D Cell.....	1507,
Battery Chargers	1507
Flashlights	
AA Cell.....	1517, 1519
Mini.....	1519
Rechargeable.....	1519
Waterproof.....	1517
Headlights, Hard Hat	419
Lanterns, 6 V	1517

ENERVAC

Vacuums, Wet / Dry	360
---------------------------------	-----

ENPAC

Absorbents	685
Berms, Spill Control	711-712
Containers, Spill Control	709-710
Covers, Drum	699
Dollies	
Drum.....	701-702
Gas Cylinder.....	1078
Drip Pans	681
Drum Equipment	
Carts.....	701
Racks.....	703
Spill Pallets.....	704-705, 710
Trays.....	681, 703, 711
Funnels, Spill Control	699
Gas Cylinder	
Brackets.....	1079
Racks.....	1079
Stands.....	1079
Leak Diverters	683
Pail Funnels	699
Pools, Spill Control	711
Salvage Drums	700-702
Stackers	703

ERB SAFETY

Bump Caps	415
Hard Hats	414-415

ERGODYNE

Anti-Vibration Gloves	607
Back Supports	641-642
Balaclavas	553
Coats, Winter	552
Ergonomic Products, Gloves	603
Folding Chairs	382
Glasses, Cord Retainers	408
Gloves, Holders	629
Hard Hat Lanyards	420, 522
Hard Hat Liners, Cooling	646
Hats, Cooling	645
Headbands, Cooling	645, 647
Headlights, Hard Hat	549
Heat Resistant Gloves	605
Hydration Backpack	647
Impact Gloves	605

Knee Pads	
Co-Polymer / Ester Tricot.....	639
Foam.....	640
Gel.....	639-640
Rubber.....	640
Kneeling Pads	639
Neck Shades, Cooling	647
Pants, Work	552
Tennis Elbow Braces	643
Tool Lanyards	522-523
Tool Storage	
Aprons.....	1391
Bags.....	1392
Holdings.....	1392
Pouches.....	523, 1390, 1392
Towels, Cooling	645-646
Undergarments	552
Undershirts	552
Vests, Cooling	646
Winter Lined Gloves	604-605
Winter Liners	553
Work Tents	382, 647
Wraps, Cooling	645, 647
Wrist Supports	643-644

ESSELTE

File Folders	1564, 1579
---------------------------	------------

EX-CELL

Carts, Laundry	303
-----------------------------	-----

EXPO ENGINEERING

Heaters	
Drum.....	237
Pail.....	237

EXTREME TOOLS

Tool Storage	
Cabinets.....	1396-1400
Carts.....	125, 1397, 1400
Chests.....	1396-1399

FAIRVIEW FITTINGS

Propane Hoses, Welding	1068
Regulators, Welding	1068

FALCON SIGNAL HORNS

Signal Horns	444
---------------------------	-----

FANTASTIK

Disinfectants	314
----------------------------	-----

FEATHERLITE

Double Stepladders	129, 131
Extension Ladders	132-133
Multi-Purpose Ladders	131-132
Platform Ladders	127, 129-131, 135
Single Ladders	127, 132-133
Stepladders	127-128, 134
Work Platforms	135

FEDERAL SIGNAL CORPORATION

Flashing Lights	222-223
Horns	221
Megaphones	444

FELLOWES

Desk Organizers	1577
Filing Boxes	1564

FELTON BRUSHES

Cup Brushes	945
End Brushes	940, 942, 944
Paint Supplies, Brushes	1046
Scratch Brushes	946-947
Tube Brushes	945
Wheel Brushes	942-944

FIBRE-METAL BY HONEYWELL

Face Shields	410, 557
Hard Hats	417

FILL-RITE

Hand Pumps	258
Rotary Pumps	258

FIRST

Fall Protection Kits	507
-----------------------------------	-----

FIRST ALERT

Disposable Gloves	656
Smoke Alarms, Ionization	655

FIRST SAFETY CORPORATION

Carts, Welding	1078
Gas Cylinder	
Brackets.....	1079
Trucks.....	1078
Racks, Welding	1078

FLAMBEAU

Small Parts Cases	36
--------------------------------	----

FLANGE WIZARD TOOLS

Pocket Levels	1115
----------------------------	------

FREUD

Circular Saw Blades	1202-1203
----------------------------------	-----------

FROST

Ashtrays	284-285
Bathroom Mirrors	350
Bicycle Racks	379
Clothes Hooks	350
Floor Signs	308
Garbage Bags	348-349
Garbage Cans	267, 270, 349-350
Grab Bar	350
Hand Dryers	351
Hand Towels	343
Liners, Waste Container	270
Paper Towel Dispensers	342-343
Recycling Containers	278
Sanitary Napkin Dispensers	348
Sanitary Napkin Receptacles	348
Sanitary Napkins	348
Shelves, Washroom	350
Soap Dispensers	326
Tampons	348
Toilet Paper Dispensers	347
Toilet Seat Cover Dispensers	348
Toilet Seat Covers	348

FULLER

Anti-Vibration Hammers	1364
Ball Pein Hammers, Anti-Vibration	1365
Cabinet Tip Screwdrivers	1340
C-Clamps	1289
Claw Hammers	1364

BRAND INDEX

Cross-Point Screwdrivers.....	1340
Curved Claw Hammers.....	1364
End Cutters.....	1349
Flat Tip Screwdrivers.....	1340
Knives, Packaging.....	1441
Precision Screwdrivers.....	1341
Pry Bars	
Multi-Purpose.....	1366
Tack Pullers.....	1340
Scratch AWL Screwdrivers.....	1340
Screwdrivers, Sets.....	1340
Spring Clamps.....	1288
Square Screwdrivers.....	1340

FULTON

Hand Winches.....	195
Industrial Jacks.....	207
Marine Jacks.....	207

GANTS LAURENTIDE

Heat Resistant Gloves.....	624
----------------------------	-----

GARANT

Axes, All-Purpose.....	368
Carpenter Axes.....	368
Club Hammers.....	369, 1366
Crowbars, Pitch Point.....	368
Cultivators.....	368
Garden Hose Hangers.....	378
Garden Spades.....	366
Grain and Coal Scoops.....	366
Hedge Shears.....	369
Hoes.....	368
Lopping Shears.....	369
Picks.....	368
Pry Bars, Nail Pullers.....	1366
Rakes.....	367
Round Point Shovels.....	366
Scoops, Aluminum.....	366
Sidewalk Scrapers.....	368
Sledge Hammers, Double Faced.....	369, 1366
Sleigh Shovels.....	365
Snow Brushes.....	364
Snow Shovels.....	364-365
Spading Forks.....	367
Square Point Shovels.....	365-366
Tree Pruners.....	369
Tree Trimmers.....	369
Turf Edgers.....	368

GARDEX

Filing Cabinets	
Lateral.....	1562
Vertical.....	1562
Safes.....	1562

GASFLUX

Flux.....	1145
-----------	------

GEARWRENCH

Combination Wrenches.....	1333
Sets.....	1334
Cross-Point Screwdrivers.....	1341
Flat Tip Screwdrivers.....	1341
Flex Head Wrenches.....	1334
Gear Wrenches, Sets.....	1333-1334
Hooks & Picks.....	1307
Impact Sockets.....	1326
Pry Bars, Multi-Purpose.....	1366
Ratcheting Wrenches.....	1333-1334
Screwdrivers, Sets.....	1341
Torque Wrenches.....	1328
Torx® Screwdrivers.....	1341

GENERAL

Bevels.....	1280-1281
Center Punches.....	1370
Inspection Mirrors.....	883
Precision Screwdrivers.....	1341

GENSTAR TECHNOLOGIES

Flowmeters, Welding.....	1068
Gas Cylinder, Wrenches.....	1073
Gas Hoses, Welding.....	1075
Gas Torches.....	1064
Heating Tips.....	1072
Outfits, Welding.....	1063-1064
Pressure Gauges, Dry.....	1068
Regulators, Welding.....	1066-1067

GENTEC

Gauge Protectors, Welding.....	1067
Heating Tips.....	1072
Outfits, Welding.....	1063
Regulator/Flowmeters, Welding.....	1068
Regulators, Welding.....	1066-1067, 1069

GERBER

Multi-Purpose Hand Tools.....	1355
Pocket Knives.....	1355

GERMIPHENE

Disinfectants.....	318, 759
Wipes.....	318, 465, 759

GILMOUR

Guns, Garden Hose.....	376
------------------------	-----

GLADE

Air Fresheners.....	322
---------------------	-----

GLOBAL

Bookcases.....	1567
Ergonomic Products, Seating.....	1547-1548
Filing Cabinets, Vertical.....	1563
Folding Tables.....	382, 1557
Monitor Mounts.....	1558
Office Desks.....	1567
Office Seating.....	1549
Stacking Chairs.....	1555
Stacking Tables.....	1556-1557
Task Seating.....	1552
Work Tables.....	1556, 1561

GOJO

Cream Dispensers.....	331
Hand Cleaners	
Cream.....	331
Foam.....	325, 329
Gel.....	328
Liquid.....	331
Lotion.....	326-329
Hand Towels.....	334, 384
Shampoo.....	329
Skin Conditioners.....	333
Skin Creams.....	333
Soap Dispensers.....	325, 330, 333

GOODWRAPPERS

Stretch Wrap	
Banding Film.....	1425
Cast.....	1424
Clear.....	1425
Coloured.....	1424
Opaque.....	1424
Stretch Wrap Dispensers.....	1424-1425

GOSS

Cutting Tips.....	1070-1072
Heating Tips.....	1072
Propane Torches.....	1064
Regulators, Welding.....	1064
Soldering Tips.....	1064
Torch Kits, Welding.....	1064

GREE

Air Conditioners.....	1500
Humidifiers.....	1500

GREENLEE

Bar Racks.....	53
Circuit Testers.....	1539

GREIF

Drums, Polyethylene.....	234
--------------------------	-----

GUARDAIR

Guns, Air.....	1228-1229
Pneumatic Pipe Fittings.....	1228
Vacuums, Accessories.....	1225

GW METAL

Garbage Cans.....	272, 383
-------------------	----------

H.K. PORTER

Bolt Cutters.....	1360-1361
Cable Cutters, Industrial Grade.....	1085, 1361
Iron Shear Cutters.....	1361
Rebar Cutters.....	1361

HANG-A-LIGHT

H.I.D. Lamps / Light Bulbs.....	1530
Task Lights.....	1530

HANNAY REELS

Reels, Welding.....	1076
---------------------	------

HARPER TRUCKS INC.

Hand Trucks.....	151
------------------	-----

HAWS

Emergency Showers.....	718-719
Eyewash, Water Heater.....	721
Eyewash Stations	
Faucet Mounted.....	720
Pedestal Mounted.....	717
Self Contained.....	722-723
Sink Mounted.....	720
Wall Mounted.....	716
Water Preservatives.....	722-723
Thermostatic Mixing Valves.....	721

HELLY HANSEN

High Visibility Clothing	
Overalls.....	543
Rain Jackets.....	543
Suits, Rain.....	543

HERBERT WILLIAMS

Escape Ladders.....	656
Extinguishers, Fire.....	652
Hazardous Materials Cabinets.....	665

HEXARMOR

Cut Resistant Gloves.....	580-581
Sleeves, SuperFabric®.....	529

HIGHLAND

Message Pads.....	1579
-------------------	------

HI-LITER

Hi-Liters.....	1578
Permanent Markers.....	1578

HILL PUMPS

Pumps, Drum.....	258
------------------	-----

HILMAN ROLLERS

Machinery Rollers.....	204-205
------------------------	---------

HILROY

Message Pads.....	1579
-------------------	------

HLF DIVERSIFIED INC.

Salt.....	364
-----------	-----

HOME SAFEGUARD INDUSTRIES, INC

Smoke Alarm Testers.....	656
--------------------------	-----

HONEYWELL

Aprons.....	531
Ball Valve Lockouts.....	783
Circuit Breaker Lockouts.....	782
Disposable Dust Masks.....	453
Disposable Respirators.....	452-453
Electrical Plug Lockouts.....	782
Eyewash Stations	
Bottled.....	724
Self Contained.....	722
Solutions.....	722-724
Supplemental.....	725
Water Preservatives.....	723, 725
Half Mask Respirators.....	458, 461
High Visibility Clothing, Rain Suits.....	543
Hoods, Rain.....	543
Lockouts, Stations.....	776
PAPR Respirators.....	480
Respirators	
Cartridges.....	461
Filters.....	461
Fit Test Kits.....	465
SCBA Respirators.....	469
Sleeves	
Canvas.....	528
Kevlar®.....	529
PVC.....	528
Vinyl.....	528
Tags, Lockout.....	789

HORIZON

Ergonomic Products, Seating.....	1547-1549
Footrests.....	1549
Keyboard Trays.....	1558
Keyboard Wrist Rests.....	1558
Office Seating.....	1546, 1548, 1554
Stacking Chairs.....	1555
Task Seating.....	1546, 1552, 1554

HOWARD LEIGHT BY HONEYWELL

Ear Muffs	
Cap Mounted.....	433-435
Headband.....	433-435, 549
Neckband.....	434
Ear Plugs	
Corded.....	423
Dispensers.....	427
Disposable.....	423-424, 427
Reusable.....	428
Hearing Bands.....	430
Two-Way Radios.....	435

HUBBELL

Cable Protectors, Office.....	218, 1540
-------------------------------	-----------

HUDSON

Sprayers, Lawn & Garden.....	372-373
------------------------------	---------

IDEAL

Spray Lubricants.....	1012, 1543
Wire Connectors.....	1543

ILLINOIS

Folding Gates.....	82-83
Security, Gates.....	82-83

IMPACTO

Anti-Vibration Gloves.....	607
Elbow Protectors.....	643
Foot Guards, Plastic.....	637
Forearm Protectors.....	643
Impact Gloves.....	607, 644
Insoles.....	638
Knee Pads	
Foam / Hard Shell.....	640
Hard Shell.....	640
Tennis Elbow Braces.....	643
Toe Guards.....	637
Wrist Supports.....	643-644, 746

INCOM TOP TAPE & LABEL

Aisle Marking Tape.....	869-870
Anti-Skid Tape.....	872
GHS	
Information Centres.....	848
Information Charts.....	847
Safety Labels.....	844
Glow in the Dark Tape.....	870
Handling Labels.....	1448
SDS	
Binders.....	849
Information Centre.....	849
Self-Adhesive Numbers.....	800
Tags, Lockout.....	789
Tape Dispensers, Aisle Marking Tape.....	868
TDG Labels.....	855, 1448
TDG Placards.....	851-854
WHMIS	
Information Charts.....	847
Posters.....	847

INNOVA

Davits.....	491
Extinguishers, Fire.....	652
Manhole Shields.....	491

INTEGRATED PLASTICS

Distribution Containers.....	23, 1564
Small Parts Cabinets.....	34
Stacking Bins.....	5

INTERCON

Weld-On Hinges.....	1088
---------------------	------

IPG

Aluminum Foil Tape.....	1415
Box Sealing Tape.....	1410, 1413
Double Sided Tape.....	1416
Duct Tape.....	1415
Filament Tape.....	1412
Gummed Tape.....	1413
Masking Tape.....	1414
Painter's.....	1050
Shrink Wrap.....	1426
Spray Adhesives.....	1036
Strapping, Tape.....	1412
Stretch Wrap	
Blown.....	1424
Cast.....	1424, 1426
Clear.....	1424
Machine.....	1426
Stretch Wrap Dispensers.....	1426
Tape Dispensers, Gummed Tape.....	1413

IRON GUARD SAFETY

Bump Guard, Forklift.....	186
Bumpers, Dock.....	213
Checklist Kit, Forklift.....	187
Dock Lights, Stop & Go.....	220
Fenders, Dock.....	212
PPE Battery Kit, Forklift.....	186
Security, Gates.....	866
Speed Bumps, Traffic Control.....	860
Spot Lights.....	187
Trailer Jacks.....	212
Wheel Chocks.....	210

IRP INDUSTRIAL RUBBER

Entrance Matting, Rubber.....	901
Hoses, Air.....	1235

IRWIN

Auger Bits.....	1199
Bar Clamps.....	1285-1287
Cable Cutters, Industrial Grade.....	1352
Chalk Lines.....	1279
Clamps, Pipe.....	1285
Drill Bits, Aircraft Extension.....	972
Forstner Bits.....	1199
Vis Grips.....	1352
Woodworking Chisels.....	1367

ITW PRO BRANDS

Stainless Steel Cleaners.....	316
Wipes.....	316, 318

JACKSON SAFETY

ADF Filters.....	1121
Chemical Resistant Gloves.....	589
Filter Plate Lenses.....	1122
Goggles, Welding.....	1120
Ground Clamps, Welding.....	1086

BRAND INDEX

Hand Shields, Welding.....	1123
Helmets, Welding.....	481, 1121-1123
PAPR Respirators.....	470, 481, 1122
Respirators, Cartridges.....	470

JACOBS

Chucks, Drill.....	1268-1269
Tool Holders, ER Collet Chucks.....	1269

JEAMAR WINCHES

Hand Winches.....	195
-------------------	-----

JET EQUIPMENT

Agricultural Jacks.....	208
Dollies, Mechanic's.....	209

JOBOX

Tool Storage	
Chests.....	1402-1403
Jobsite Boxes.....	1401-1407
Van and Truck Equipment.....	1407

JOHNSON

Bevels.....	1280
Carpenter Squares.....	1280
I-Beam Frame Levels.....	1281
Laser Levels.....	1282-1283
Rafter Squares.....	1280
T Squares, Drywall.....	1280
Torpedo Levels.....	1281
Try Squares.....	1280

JOMAC CANADA

Chemical Resistant Gloves.....	592
Cut Resistant Gloves.....	577, 579, 581
Heat Resistant Gloves.....	622-623
Heat Resistant Mitts.....	622
Knit Gloves.....	629
Sleeves	
Cotton.....	528
Kevlar®.....	529

JUSTRITE

Ashtrays.....	236, 284, 657
Bench Cans.....	992
Cabinet Carts.....	660, 662
Cabinets, Drum.....	663, 665
Cans, Safety.....	668-669
Covers, Drum.....	236, 670
Crimpers, Cap Seal.....	250
Dip Tanks.....	992
Dipping Baskets.....	992
Dispenser Bottles.....	672
Drip Cans.....	670
Drum Equipment	
Spill Pallets.....	706-708
Trays.....	681
Funnels, Drum.....	251, 699
Gas Cylinder, Cabinets.....	1077
Gauges, Drum.....	251
Hazardous Materials Cabinets.....	660-667
MSDS, Storage Boxes.....	667
Oily Waste Cans.....	670-671
Plunger Cans.....	670
Rinse Tanks.....	992
Vents, Drum.....	251
Wash Tanks.....	992

KALAS

Cables, Welding.....	1085
----------------------	------

KANT-TWIST

Clamps, Pipe.....	1285
-------------------	------

KEE KLAMP

Kee Klamp® Pipe Fittings.....	79-81
Pneumatic Piping.....	81

KEY-BAK

Chucks, Drill.....	1269
Key Chains.....	1570-1571
Label Holders.....	1571

KILOTECH

Bench Scales.....	1493-1495
Counting Scales.....	1491
Crane Scales.....	203, 1496
Dial Scales.....	1494
Hanging Scales.....	203, 1496
Platform Scales.....	1495
Portable Scales.....	1493
Receiving Scales.....	1494
Test Weights.....	1496
Weighing Scales.....	1491-1492

KIMBERLY-CLARK

Coated Gloves.....	564
Coveralls	
General Protection.....	539
Limited Use.....	539
Cut Resistant Gloves.....	578
Disposable Gloves.....	596-597
Lab Coats, General Protection.....	539
Wipes.....	337-338
Wipes Dispensers.....	338

KIMBERLY-CLARK PROFESSIONAL

Blankets, Welding.....	1118
Helmets, Welding.....	1123
Screens, Welding.....	1118-1119
Umbrellas, Welding.....	1118

KINEDYNE

Cargo Bars.....	212, 1457
Decking Beams.....	212, 1457
Jack Bars.....	1457
Load Binders.....	192
Logistic Straps.....	246, 1456
Logistic Tracks.....	212, 1457
Ratchet Straps.....	1456
Tie-Downs.....	1456-1457

KING CANADA

Arbor Presses.....	208
Bench Grinders.....	917, 1270
Brushes, Parts Cleaning.....	993
Chop Saws.....	914, 1174
Compressors, Air.....	1263
Drill Presses	
Bench.....	1266-1267
Floor.....	1266-1267
Engine Tilters.....	208
Engine-Powered Pumps.....	264
Gearhead Machines, Drilling.....	1267
Guns	
Air.....	1051
Paint.....	1051
Hand Lamps.....	1528
Media Recyclers, Sandblasting.....	1055
Mitre Saws.....	1176
Parts Washers.....	993
Portable Blasters, Sandblasting.....	1055

Shop Cranes.....	208
Work Stands.....	225

KLEEN-FLO

Battery Acid Neutralizers.....	1037
--------------------------------	------

KLEIN TOOLS

Bolt Holder Pliers.....	1349
Cabinet Tip Screwdrivers.....	1339
Cable Cutters	
Industrial Grade.....	1349, 1351
Insulated.....	1377
Crimping Die Pliers.....	1349, 1377
Cross-Point Screwdrivers.....	1339, 1378
Diagonal Cutters.....	1350, 1377
Flat Tip Screwdrivers.....	1339, 1378
Locking Pliers.....	1351
Long Nose Pliers.....	1351, 1377
Needle Nose Pliers.....	1351
Nose Cutting Pliers.....	1350
Nut Drivers	
Cushion Grip.....	1342
Insulated.....	1378
Magnetic.....	1342
Sets.....	1342
Pump Pliers.....	1377
Rebar Tie Wire Cutters.....	1350
Screwdrivers, Sets.....	1339
Side Cutting Pliers.....	1349, 1351, 1377
Slip Joint Pliers.....	1349
Square Screwdrivers.....	1339
Technicians' Tools.....	1378-1379
Tongue & Groove Pliers.....	1349
Tool Storage	
Bags.....	1393, 1464
Belts.....	1389
Holders.....	1387-1388
Pouches.....	1387-1388, 1390-1391
Torque Screwdrivers.....	1329
Torx® Screwdrivers.....	1339
Wire Strippers.....	1351
Wire Stripping Pliers.....	1377

KLETON

Bag Sealing Tape.....	1436
Bar Racks.....	53
Beam Trolleys.....	190
Bin Carts.....	7-8
Bin Racks.....	8-9, 121
Bin Shelves.....	17, 60
Bin Support Panels.....	7
Bins, Steel.....	44
Bollards.....	54, 85
Box Sealing Tape.....	1410
Box Trucks.....	166, 172-173, 175
Bumpers, Dock.....	213
Cabinets, Storage.....	9-10, 99-100
Carton Rack.....	1434
Carts, Welding.....	1078
Casters.....	137, 152-154, 162, 164-165, 176-177, 227-228, 245-246
Corkboards.....	1569
Diaphragm Pumps.....	258
Dollies	
Aluminum.....	177
Drum.....	244
Wood.....	176
Drywall Carts.....	159
Extensions, Forklift.....	187
Faucets, Drum.....	252
Folding Chairs.....	1554
Folding Tables.....	382, 1557
Furniture Pads.....	1454
Gas Cylinder, Cabinets.....	1077
Guard Rails.....	54, 84-85
Hand Pumps.....	256
Hand Trucks.....	144-146, 149-151, 1454, 1554

Hoists, Manual.....	190
Horizontal Sheet Rack.....	53
Lift Tables.....	178
Lifters, Drum.....	238, 243
Locker Room Benches.....	108, 382
Lockers, Steel.....	105
Lumber Carts.....	159-160
Maintenance Platforms.....	141
Mesh Enclosures.....	90
Mesh Partitions.....	51, 84-85, 88-89
Order Picking Carts.....	165
Pallet Pullers.....	186
Pallet Trucks.....	144, 182-183
Panel Trucks.....	160
Perimeter Guards.....	51, 84-85, 88
Pipe Trucks.....	160
Platform Trucks	
Aluminum Deck.....	155-156
Dead Skids.....	154
Non-skid Vinyl Deck.....	156
Plastic Deck.....	156
Semi-Live Skids.....	154
Steel Deck.....	152-153, 155, 160, 165
Wood Deck.....	153-154
Pumps, Drum.....	254-257
Racks, Drum.....	245
Reel Dispensers.....	167
Rockers, Drum.....	245
Rolling Ladders.....	135, 137-138
Rotary Pumps.....	257
Seals, Steel.....	1419
Service Benches.....	123-125
Shelf Carts.....	73, 76, 162-165, 167
Shelving Units	
Chrome.....	17, 70-72, 75
Steel Wire.....	73
Shop Carts.....	164
Shop Desks.....	126
Small Parts Bins.....	31
Small Parts Cabinets.....	30-32, 38
Stackers.....	180
Stacking Bins.....	4-5, 17
Stacking Racks.....	53-54
Stepstands, Steel.....	136
Stepstools, Polyethylene.....	136, 1549
Stock Picking Carts.....	165
Stock Trucks.....	166
Strapping	
Dispensers.....	1420
Machines & Tools.....	1419, 1422
Steel.....	1419
Stretch Wrap Dispensers.....	1424
Strip Curtain Doors.....	92
Tape Dispensers	
Box Sealing Tape.....	1411, 1429
Filament Tape.....	1412
Tarpaulins.....	379, 1453
Tie-Downs.....	683, 1455
Tilt Trucks.....	173
Tipplers, Pail.....	245
Tool Storage, Carts.....	123
Trailer Jacks.....	212
Transfer Boxes.....	19
Trucks, Drum.....	246
Utility Carts.....	76, 166, 168
Valves, Drum.....	252
Vents, Drum.....	251
Vertical Sheet Rack.....	53
Wagons.....	154
Wheel Chocks.....	210
Wheels.....	144, 246
Whiteboards.....	1569
Work Platforms.....	135-136
Work Tables.....	120
Workbenches.....	103, 112-117, 120-123, 1432
Wrenches, Drum.....	250

KNIPEX

Technicians' Tools.....	1379
-------------------------	------

KNUFFI

Edge Protectors.....	87, 216
----------------------	---------

KODIAK POWER EQUIPMENT

Engine-Powered Pumps.....	264
Pressure Washers.....	374-375

KRYLON INDUSTRIAL

Marking Wands.....	1038-1039
--------------------	-----------

Paint

Acrylic.....	1040, 1042-1044
Alkyd.....	1040-1041, 1043-1044
Epoxy.....	1042
Floor.....	1019
High Heat.....	1042-1043
Latex.....	1042
Line Striping.....	1039
Marking.....	1038
Paint Supplies, Paint Remover.....	1039
Striping Machines.....	1039

KUNY'S

Cell Phone, Holders.....	1387, 1390
Suspenders.....	1389

Tool Storage

Aprons.....	1391
Bags.....	1391-1393
Belts.....	1389
Boxes.....	1393
Holders.....	1387-1388
Pouches.....	1387-1388, 1390-1392

KYORITSU

Phase Rotation Testers.....	1468
-----------------------------	------

L.B. WHITE

Fan Forced Heaters.....	1505
Radiant Heaters.....	1504-1505

LA-CO INDUSTRIES INC

Teflon® Tape.....	1416
-------------------	------

LAKELAND

Coveralls, Limited Use.....	538
-----------------------------	-----

LAKESIDE MATERIAL HANDLING

Equipment Stands.....	170
Shelf Carts.....	170
Utility Carts.....	170

Laurin

Tilt Trucks.....	172
------------------	-----

LAVO

Bleach.....	314
-------------	-----

LENCO

Cable Connectors, Welding.....	1084
Chipping Hammers, Welding.....	1087

LEPAGE

Wood Fillers.....	1022
-------------------	------

LEV-CO

Air Filters.....	1058
Fume Extractor Fans.....	1058

Fume Extractors.....	1058-1060
Fume Filters, Welding.....	1058-1059
Mechanical Filters.....	1059
Portable Blowers.....	1059
Pressure Gauges, Dial.....	1058

LEWIS BINS+

Distribution Containers.....	18, 20
Dollies, Stacking.....	20
ESD Products, Bins.....	25

LIFE SAFE

Snow Clearing Posts.....	871
--------------------------	-----

LIFT-RITE

Pallet Lifters.....	184
Pallet Trucks.....	186
Stackers.....	180

LINCOLN ELECTRIC

Cold Wire Feeders, TIG Torch.....	1091
MIG Welders.....	1092-1093
Plasma Cutters.....	1090
Stick Electrodes.....	1136
TIG Welders.....	1091
Water Cooled Torches.....	1091

LIND EQUIPMENT

Batteries, C Cell.....	444, 1518
Bonding & Grounding Wires.....	252-253
Cable Protectors, Dock.....	217

Cord Reels

Extension Cords.....	1531-1532, 1537
Fluorescent.....	1532
Incandescent.....	1531-1532
Quad Box.....	1531
Single Outlet.....	1531
Triple Outlet.....	1532
Work Lights.....	1531

Cord Sets, GFCI.....	1539
----------------------	------

Dock Lights

Flexible.....	218
Halogen.....	218
Single Strut.....	218

Extension Cords

Circuit Breaker.....	1538
Single Outlet.....	1538

Floodlights.....	1526-1528
------------------	-----------

Floor Lamps.....	1527
------------------	------

Fluorescent Lamps / Light Bulbs.....	1525-1526
--------------------------------------	-----------

Halogen Lamps / Light Bulbs.....	1527-1528
----------------------------------	-----------

Hand Lamps.....	1525-1527
-----------------	-----------

Headlights, Hard Hat.....	419
---------------------------	-----

Outlet Adaptors, GFCI.....	1540
----------------------------	------

Outlet Boxes, GFCI.....	1539
-------------------------	------

Plugs, GFCI.....	1540
------------------	------

Spot Lights.....	1518
------------------	------

String Lights.....	1528
--------------------	------

Telescopic Lights.....	1528
------------------------	------

LISTA

Cabinets, Storage.....	94-96
Open Wire Workstations.....	118
Shelving, Drawer Insert.....	68-69
Workbenches.....	118-119

LITTLE GIANT PUMP COMPANY

Coolant Tanks.....	1150
Machine Tool Pumps.....	1150
Multi-Purpose Ladders.....	1150
Submersible Pumps.....	262-263, 1150
Transfer Pumps.....	263

BRAND INDEX

LLOYDS

Air Tool Oil.....1037, 1261
Graffiti Removers.....319, 1005

LOC-LINE

Loc-Line® Hosing.....1150-1153

LOCTITE

Accelerators, Adhesive.....1032
Adhesives
Acrylic.....1034
All Purpose.....1023
Aluminum Foil Tape.....1020
Anti-Seize.....1016
Anti-Slip Floor Coatings.....873, 1019
Bolt Removal Penetrants.....1013
Caulking Guns.....1035
Construction Adhesives.....1029
Contact Cleaners.....1007
Dielectric Greases.....1018
Epoxies
for Metal.....1020-1021
General Purpose.....1033-1034
Mixer Cups.....1021
Putty.....1020-1021
Syringe.....1021
Two Part.....1033
Epoxy Applicators.....1021, 1035
Fault Detectors, Welding.....1012, 1148
Flange Sealants.....1026
Floor Repair.....1019, 1021
Floor Sealers.....1019
Gaskets.....1025-1026
Glue Guns.....1035
Guns, Air.....1035
Instant Adhesives.....1031-1032
Paint, Rubber.....1012
Primers, Adhesive.....1032
Retaining Compounds.....1027
Rust Converters.....1014, 1146
Sealants, Silicone.....1025
Spray Lubricants.....1018
Structural Adhesives.....1032-1034
Synthetic Greases.....1018
Teflon® Tape.....1028
Thread Sealants.....1026
Threadlockers.....1020, 1027-1028
White Lithium Greases.....1018

LOUISVILLE LADDER

Double Stepladders.....130-131
Platform Ladders.....130
Scaffolding.....134
Stepstools, Fiberglass.....134

LPS

Anti-Seize.....1016
Anti-Spatter.....1147
Bearing Greases.....1017
Belt Dressing.....1012
Brake Cleaners.....1005
CFC Free Degreasers.....1002
Contact Cleaners.....1005-1006
Cutting Fluids, for all Metals.....1149
Degreasers
Heavy-Duty.....1002-1003
Multi-Purpose.....1002-1004
Dusters, Aerosol.....1006
Galvanizing Compounds.....1014, 1146
Hand Towels.....334, 1005
High Temperature Greases.....1017
Industrial Cleaners, Multi-Purpose.....1003
Machinery Oil.....1011
Multi-Purpose Greases.....1011, 1018

Penetrants

KB 88.....1013
Multi-Purpose.....1013
Permanent Markers.....1442
Rust Preventers.....1014, 1146
Solvent Free Degreasers.....1002-1003
Spray Lubricants.....1008-1011, 1013
White Lithium Greases.....1018

LUFKIN

Measuring Tape
Oil Gaging.....1279
Retractable Blade.....1276, 1278
Measuring Wheels.....1278
Plumb Bobs.....1279

LUXO

Magnifiers, Illuminated.....1524

LUXOR H. WILSON

Audio-Visual Carts.....1561
Computer Carts.....1561
Work Tables.....1556, 1561

LYON

Cabinets, Storage.....98-99
Lockers, Steel.....108
Shelving Units, Steel.....58

M & P TOOL PRODUCTS

Bins, Steel.....44

MAGIC

Stations, Lens Cleaning.....409
Tissues, Lens Cleaning.....409

MAGLINER

Dollies, Aluminum.....177
Hand Trucks.....148-149
Wheels.....148

MAGLITE

Flashlights
AA Cell.....1511
AAA Cell.....1509-1510
Belt Holsters.....1509-1511
CR123 Cell.....1511
D Cell.....1509-1510
Mini.....1509
Rechargeable.....1511
Traffic Wands.....1509

MAG-MATE

Bar Magnets.....1298
Ceramic Magnets.....1299
Cup Magnets.....1299
Ground Clamps, Welding.....1086
Grounds, Welding.....1086
Inspection Mirrors.....883
Magnetic Lifters.....198, 1298
Magnetic Retrievers.....1297-1298
Print Holders.....1298
Rare Earth Magnets.....1299
Squares, Welding.....1086
Strip Magnets.....1298
Sweeper Magnets.....286
Sweepers.....286

MAGNAFLUX

Fault Detectors, Welding.....1020, 1144
Non-Chlorinated Cleaners.....1020, 1144
Non-Chlorinated Developers.....1020, 1144
Penetrants, Water Based.....1144

MAKITA

Angle Drills, Electric.....1184
Angle Grinders, Electric.....916, 1163, 1168-1169, 1171
Battery Chargers, Cordless Drill.....1167
Chop Saws.....1174
Circular Saws, Heavy-Duty.....1177
Combo Kits.....1164-1166
Compressors, Air.....1262
Cordless Power Tool Batteries 1156-1157, 1160-1161, 1164, 1167
Cordless Screwdrivers.....1161, 1187
D Handle Drills.....1183
Demolition Hammers.....1187
Die Grinders, Electric.....1172
Drills, Drill / Drivers - Cordless.....1156-1158
Flashlights
12 V.....1162
18 V.....1162
Rechargeable.....1162
Hand Powered Drills.....1182
Heat Guns.....1190
Impact Wrenches
Cordless.....1160
Electric.....1181
Jig Saws
Heavy-Duty.....1178
Orbital.....1178
Mitre Saws.....1175
Nibblers.....1173
Palm Sanders.....1180
Power Scrapers.....1186
Reciprocating Saws, Electric.....1179
Shears, Power.....1173

MALLORY

Extension Poles.....297, 299
Round Nose Pliers.....364
Snow Brushes.....364
Snow Shovels.....364
Squeegees.....296, 299
Window Washers.....299

MAPA PROFESSIONAL

Chemical Resistant Gloves.....585, 589-590

MARIGOLD INDUSTRIAL

Chemical Resistant Gloves.....585, 589-590, 588-589
Gloves, High Voltage.....558

MARINO

Bags, Laundry.....303
Boot Brushes.....291
Broom & Mop Racks.....286
Buckets.....306
Carts, Laundry.....303
Floor Scrapers.....292
Garbage Cans.....272
Hand Scrubbers.....302, 320
Litter Pickers.....282, 383
Litter Scoops.....282, 383
Magnetic Brooms.....290
Nippers, End Cut.....282, 383
Plungers, Toilet.....349
Trigger Sprayers.....302, 320

MARKAL

Grease Pencils.....1142, 1445

Liquid Tip Markers.....	1445
Lumber Crayons.....	1142, 1444
Metal Markers.....	1444
Paint Markers.....	1142, 1443-1444
Paint Sticks.....	1142, 1443-1444
Permanent Markers.....	1445
Teflon® Tape.....	1027
Temperature Crayons.....	1142, 1445
Whiteboard Markers.....	1569

MARLEY INDUSTRIAL PRODUCTS

Portable Blowers.....	1060
Portable Heaters.....	1504
Radiant Heaters.....	1504
Wall Heaters.....	1504

MARSH

Fountain Brushes.....	799
Fountain Rollers.....	799
Hand Rollers.....	799
Stencil Inks.....	799

MASTER LOCK

Ball Valve Lockouts.....	780, 782-784
Bungee Cords.....	1455, 1457
Butterfly Valve Lockouts.....	783
Cable Lockouts.....	779
Circuit Breaker Lockouts.....	781
Dielectric Hasp Lockouts.....	780
Electrical Plug Lockouts.....	781
Electrical Switch Lockouts.....	781
Gate Valve Lockouts.....	784
Hasp Lockouts.....	764, 768-769, 780
Key Cabinets.....	1570
Key Tags.....	1570
Lock Labels.....	770
Lockouts	
Confined Space.....	784
Kits.....	772, 778-779
Stations.....	773-775
Padlock Caddy.....	773
Padlocks.....	110, 764-772
Pneumatic Fitting Lockouts.....	1250
Safes.....	1577
Tie-Downs.....	1456

MAT TECH

Anti-Fatigue Matting.....	908-909
Entrance Matting	
Carpet.....	886-887
Eco.....	886
Needle Rib.....	885
Pile.....	885-887
Polypropylene.....	885
Rubber.....	886-887, 909
Wiper.....	874, 885-887

MATRIX INDUSTRIAL PRODUCTS

Ceiling Mounted Heaters.....	1504
Drum Fans.....	1502
Fan Forced Heaters.....	1503
Floor Fans.....	1499
Office Fans.....	1499
Pedestal Fans.....	1497, 1499
Radiant Heaters.....	1503
Radiator Heaters.....	1503
Wall Clocks.....	1575
Wall Mounted Fans.....	1497, 1499

MAYFIELD

Funnels, Steel.....	993
Liquid Measures.....	993

MECHANIX WEAR

Anti-Vibration Gloves.....	606
Ergonomic Products, Gloves.....	602, 605
Impact Gloves.....	606
Leather Gloves.....	621, 1131

MEGAPRO

Multi-Tip Screwdrivers.....	1341
-----------------------------	------

MEGGER

Insulation Testers.....	1467
-------------------------	------

MELNOR

Garden Hoses.....	378
Guns, Garden Hose.....	376
Oscillators, Garden Hose.....	376
Repair Kits, Hose.....	377
Sprinklers, Garden Hose.....	376
Timers, Mechanical.....	378

MERIT

Backing Pads.....	922
Cartridge Rolls.....	929
Disc Holder Pads.....	922, 924
Flap Wheels.....	920
Power-Lock Discs.....	924
Resin Fibre Discs.....	922
Spiral Bands.....	929

METABO

Hammer Drills.....	1184
Heat Guns.....	1190

METALTECH

Extension Ladders.....	135
Scaffolding.....	141-143

METALWARE

Shelving Units	
Steel.....	62-67
Widespan.....	57

METRO

Garbage Cans.....	169
Security, Carts.....	77
Shelf Carts.....	77
Shelving Units	
Chrome.....	74
Plastic.....	75
Steel Wire.....	75
Utility Carts.....	169
Workbenches.....	120

MICRELL

Hand Cleaners, Lotion.....	324
Soap Dispensers.....	324

MIDWEST

Table Caddies.....	1557
--------------------	------

MILLER BY HONEYWELL

Anchorage Connectors.....	519
Arc Rated Harness.....	500, 560
Arc Rated Lanyards.....	510, 560
Beam Clamps.....	519
Beam Trolleys.....	519
Carabiners.....	520
Cross-Arm Strap Anchors.....	519, 560

D-Bolt Anchors.....	519
Fall Protection, Harnesses.....	497-499
Fall Protection Kits.....	505
Rescue Systems.....	492
Rope Grabs.....	520
Self-Retracting Life Lines.....	514-515
Shock Absorbing Lanyards.....	508-510
Tie-Back Lanyards.....	509-510
Vertical Life Lines.....	520
Welding Harnesses.....	500
Welding Lanyards.....	510

MILLSIDE

Wagons.....	370
-------------	-----

MILWAUKEE

Angle Drills, Electric.....	1184
Angle Grinders, Electric.....	916, 1163, 1168-1170
Bandsaws	
Metal Cutting.....	1178
Wood Cutting.....	1178
Battery Chargers, Cordless Drill.....	1167
Chop Saws.....	914, 1174
Circular Saws, Heavy-Duty.....	1162, 1177
Close Quarter Drills.....	1184
Combo Kits.....	1164-1166
Cordless Power Tool Batteries.....	1156-1164, 1167
Core Bits.....	1194
Coring Motors.....	1189
D Handle Drills.....	1183-1184
Die Grinders, Electric.....	1172
Drill Bits	
Hex Shank.....	1198
Through-Hole.....	1199
Two-Piece.....	1193
Drill Presses, Electromagnetic.....	1188-1189
Drills, Drill / Drivers - Cordless.....	1156, 1161, 1164
Flashlights	
12 V.....	1162
Rechargeable.....	1162
Floodlights.....	1162
Grease Guns.....	1161
Hammer Drill / Drivers.....	1157-1159
Hammer Drills.....	1158-1159, 1185-1187
Hand Chisels.....	1194
Hand Powered Drills.....	1182-1183, 1186
Heat Guns.....	1190
Hole Saw Arbors.....	1193, 1198
Hole Saws.....	1197-1198
Impact Wrenches	
Cordless.....	1159-1160
Electric.....	1181
Infrared Thermometers.....	1470
Jig Saws, Orbital.....	1178
Knockout Tools.....	1162
Mitre Saws.....	1176
Nibblers.....	1173
Palm Sanders.....	1180
Points, Cutting.....	1194
Reciprocating Saw Blades.....	1201
Reciprocating Saws	
Cordless.....	1163
Electric.....	1179
Rotary Cutters.....	1163
Rotary Hammers.....	1159, 1186-1187
Scaling Chisels.....	1194
Screw Guns.....	1187
Shears, Power.....	1173

MMF INDUSTRIES

Key Cabinets.....	1570
Key Racks.....	1570
Key Tags.....	1570

BRAND INDEX

MOBILE INDUSTRIES

Pallet Trucks.....	184-186
Stackers.....	180

MOLDEX

Disposable Respirators.....	450-451
Ear Muffs	
Headband.....	435
Hygiene Kits.....	435
Ear Plugs	
Dispensers.....	427
Disposable.....	426
Reusable.....	426, 429
Full Face Respirators.....	462
Half Mask Respirators.....	462
Hearing Bands.....	431
Respirators	
Cartridges.....	462
Welding.....	450

MONOFLO INTERNATIONAL, INC.

Pallets, Plastic.....	47
-----------------------	----

MORSE

Dollies, Drum.....	244
Funnels, Drum.....	241
Lifters, Drum.....	239-243
Rotators, Drum.....	248
Spotters, Drum.....	247
Tilters, Drum.....	239-240
Trucks, Drum.....	247
Tumblers, Pail.....	248
Upenders, Drum.....	250
Wrenches, Drum.....	250

MOTOROLA

Two-Way Radios.....	441-442
---------------------	---------

MR. CHAIN

Chain, Crowd Control.....	880
Posts, Crowd Control.....	880

MR. CLEAN

Floor Cleaners.....	317
---------------------	-----

MRB

Shrink Wrap Machines.....	1426
---------------------------	------

MSA

Docking Stations.....	485-486
Ear Muffs, Cap Mounted.....	439
Faceshields.....	413
Full Face Respirators.....	463
Gas Detectors	
Calibration Gas.....	485-486
Sensor.....	485-486
Half Mask Respirators.....	463-464
Hard Hats.....	417-418
Multi-Gas Detectors.....	485-486
Regulator, Calibration Gas.....	485-486
Respirators	
Cartridges.....	463-464
Filters.....	464
Single-Gas Detectors.....	485

MUR-VAN

Casters.....	1550
Office Seating.....	1554
Swivel Stools.....	1554
Task Seating.....	1550-1552, 1554

MUSCLE MATE

Bins, Steel.....	45
Floor Cranes.....	200, 202
Gantry Cranes.....	200
Jib Booms.....	201
Jib Cranes.....	201
Pallet Lifters.....	201
Shop Cranes.....	202
Truck Mounted Cranes.....	202

NALGENE

Bottles, Storage.....	28
Jars, Storage.....	28

NAS

Shelving Units, Steel.....	57
Tire Racks.....	78

NASHVILLE WIRE

Collapsible Containers.....	44
-----------------------------	----

NEOS

Overshoes.....	634
----------------	-----

NEPTUNE

Mixers	
Drum.....	249
Pail.....	249

NEXAL

MIG Wire, Aluminum.....	1138
-------------------------	------

NICHOLSON

File Cleaners.....	1307
File Handles.....	1307
Files, Sets.....	1306-1307
Flat Files.....	1302-1305
Hacksaws	
Blades.....	1300
Frames.....	1301
Half Round Files.....	1303
Half Round Rasps.....	1305
Round Files.....	1302, 1304
Round Rasps.....	1305
Square Files.....	1304
Thread Repair, Files.....	1307
Triangular Files.....	1304-1305

NILFISK

Vacuums, Wet / Dry.....	361, 688
-------------------------	----------

NOGA

Deburring Hand Tools.....	1308
---------------------------	------

NORTECH

Vacuums, Wet / Dry.....	361
-------------------------	-----

NORTH BY HONEYWELL

Anchorage Connectors.....	519
Bump Caps.....	417
Carabiners.....	520
Chemical Resistant Gloves.....	584, 592
Davits.....	491
Disposable Respirators.....	452
Emergency Escape Respirators.....	459
Faceshields.....	410-411
Fall Protection, Harnesses.....	501-502, 519
Fall Protection Kits.....	505-506

Full Face Respirators.....	458-459, 469
Glasses, Safety.....	397-398
Half Mask Respirators.....	458, 469
Hard Hats.....	416-417
PAPR Respirators.....	480
Rescue Hoist.....	492
Rescue Systems.....	492
Respirators	
Cartridges.....	460, 480
Filters.....	452, 459, 480
Rope Grabs.....	520
Sandblasting Gloves.....	591
Self-Retracting Lanyards.....	515
Self-Retracting Life Lines.....	515
Shock Absorbing Lanyards.....	510
Vertical Life Lines.....	520

NORTON

Backing Pads.....	927
Benchstand Belts.....	929
Circular Saw Blades.....	914
Crimped Filament Wheels.....	912-913
Cut-Off Wheels.....	912-915
Flap Discs.....	918-919
Grinding Wheels	
Bench Mounted.....	917, 1271
Type 27.....	915-916
Zirconium.....	913-915
Grip-On Discs.....	926
Portable Belts.....	928
Portable File Belts.....	928
Power-Lock Discs.....	924
Sandpaper.....	931
Stick-On Discs.....	926-927
Surface Conditioning Discs.....	934
Surface Conditioning Pads.....	933
Surface Conditioning Rolls.....	930, 934

NUCO

Caulking Guns.....	1023
Construction Adhesives.....	1029
Epoxies	
General Purpose.....	1023
Putty.....	1023
Foam Sealants.....	1023

OASIS

Water Filters.....	1585
Water Fountains.....	1585-1586

OATEY

Pipe Cements.....	1022
Plumbers' Putty.....	1022
Teflon® Tape.....	1416

OBERDORFER

Pumps, Drum.....	258
------------------	-----

OETIKER INC

Hose Repair Kits, Welding.....	1075
--------------------------------	------

OHAUS

Bench Scales.....	1491-1492, 1495
Floor Scales.....	1496
Platform Scales.....	1495
Portable Scales.....	1492

OIL-DRI

Absorbents.....	684
-----------------	-----

OLD DUTCH

Scouring Powder.....316

OLFA

Blades, Packaging Knife.....1425, 1430, 1434, 1438-1439, 1442
Cases, Blade Disposal.....1438
Knives, Packaging.....1425, 1430, 1434, 1438-1439, 1442
Scissors, Industrial.....1442
Utility Knives.....1442

OLYMPIC

Wire Measurers.....1484

OMEGA COMPRESSORS

Compressors, Air.....1263

OMNIGLOW

Lightsticks.....860

ONGUARD INDUSTRIES

Boot Covers.....632
Chemical Resistant Boots.....631
Chest Waders.....633
Hip Waders.....633
Knee Boots.....631-632
Overboots.....633
Overshoes.....633
Work Boots.....632

OPTREL

ADF Filters.....1124-1125
Beanies, Welding.....1125
Chest Protectors, Welding.....1125
Helmets, Welding.....1124-1125
Neck Protectors, Welding.....1125

ORBIS

Collapsible Containers.....45
Distribution Containers.....22-23
ESD Products, Bins.....25
Pallets, Plastic.....46-48, 1423

OSBORN

Brushes
Acid.....1141, 1145
Parts Cleaning.....993
Compressors, Air.....1264-1265
Paint Supplies, Brushes.....1046
Scrub Brushes.....291, 946
Wheel Brushes.....941, 1271

PACER

Pumps, Drum.....258

PANAVISE

Tilting Vises.....1296

PAPER MATE

Pencils.....1578
Pens, Office.....1578

PARCO

Bicycle Racks.....379

PARTLOW

Temperature Recorders.....1476

PELICAN

Cell Phone
Accessories.....443
Holders.....443
Equipment Cases.....1465
Flashlights
AA Cell.....1514, 1516, 1518
AAA Cell.....1514
C Cell.....1516
Coin.....1514
Mini.....1514
Waterproof.....1518
Floodlights.....1530
Task Lights.....1530

PELTOR

Ear Muffs
Cap Mounted.....436-438
Headband.....436-438
Neckband.....436-437
Two-Way Radios.....438-439

PERFIX INC.

Filing Cabinets, Lateral.....1563
Lockers, Steel.....107

PESOLA

Hanging Scales.....1493

PHOENIX INTERNATIONAL

Electrode Ovens.....1089
Rod / Electrode Containers.....1089

PICQUIC

Hex Square Drive Bits.....1340
Multi-Tip Screwdrivers.....1340

PLASTIC RECYCLING

Bollards.....865
Park Benches.....380
Parking Curbs, Traffic Control.....861
Picnic Tables.....380

PLASTICOR

Anti-Fatigue Matting.....906

PLEDGE

Furniture Polish.....319

PLUMB

Ball Pein Hammers
Fiberglass Handle.....1365
Wood Handle.....1365
Blacksmiths' Hammers.....1366
Brick Hammers.....1364
Claw and Ripping Hammers.....1364
Claw Hammers.....1364
Curved Claw Hammers.....1364
Double Faced Hammers.....1366
Scaling Hammers.....1364

POLARPRO

Forks, Cafeteria.....1583
Knives, Cafeteria.....1583
Spoons, Cafeteria.....1583

POLYAIR

Bubble Mailers.....1435

Bubble Pouches.....1435
Bubble Wrap.....1427
Foam, Packaging.....1427

PORTER CABLE

Belt Sanders, Electric.....1180

POST-IT

Message Pads.....1579

PR88

Hand Creams.....333

PRECISION BRAND

Feeler Gauge Stock.....1274
Shims.....1273-1274
Stock.....1274

PRECISION TWIST DRILL

Combined Drills & Countersinks.....961
Drill Bits
Jobber.....949-953
Silver & Deming.....954
Stub.....953-954
Taper Shank.....955

PRIME

Cord Reels, Extension Cords.....1537
Cord Sets, GFCI.....1539
Extension Cords
Double Outlet.....1541
Single Outlet.....1536, 1538, 1541
Triple Outlet.....1535-1536
Power Bars.....1541
Power Strips, GFCI.....1540-1541

PROBUILT PROFESSIONAL

Flashing Lights.....863
Fluorescent Lamps / Light Bulbs.....1529-1530
Task Lights.....1529-1530

PRODUITS RE-PLAST

Park Benches.....380
Picnic Tables.....380

PROTECTA

Anchorage Connectors.....516
D-Bolt Anchors.....516
Fall Protection, Harnesses.....496
Fall Protection Kits.....507
Rescue Systems.....490
Rope Grabs.....517
Self-Retracting Lanyards.....513
Self-Retracting Life Lines.....513
Shock Absorbing Lanyards.....508
Welding Harnesses.....496

PROTECTIVE LINING CORP

Inserts, Pail.....235
Liners, Drum.....235

PS DOORS

Security, Gates.....84

BRAND INDEX

PTC INSTRUMENTS

Hardness Testers	
Non-Metals.....	1479
Steel & Alloys.....	1479

PURDY

Paint Supplies, Brushes	1048
--------------------------------------	------

PURELL

Hand Sanitizer Dispensers	323-324
Hand Sanitizers	323-324, 760

PYROCHEM

Extinguishers, Fire	652
----------------------------------	-----

QRP

Disposable Gloves	596, 598
Fingercots	600

QUALITY RAILINGS

Dock Equipment	
Dockboards.....	215
Dockplates.....	215
Twin Ramps	214
Walkkramps	214
Wheel Risers	215

QUANTUM STORAGE SYSTEM

Bin Racks	39
Bin Shelves	16, 21, 59
Cabinets, Storage	35
Distribution Containers	19
Gaylord Liners	4
Mobile Bins	6
Nesting Bins	19, 26
Shelf Bins	13, 15, 25
Small Parts Bins	25, 39
Stacking Bins	6, 13, 16, 21, 26
Storage, Stacking Bins	4

QUARTET

Audio-Visual Carts	1560
Whiteboard Dry Erase Wipes	1569

RABCO

Boot Brushes	889
---------------------------	-----

RALSTON MIRRORS

Inspection Mirrors	883
---------------------------------	-----

RAYTEK

Infrared Thermometers	1469
------------------------------------	------

RED KAP

Coveralls, Work	550
Lab Coats	550
Pants, Work	550
Shirts, Work	550
Shop Coats	550

REED

Air Quality Monitors	487, 1474
Alligator Clips	1460, 1463
Batteries, 6 Volt	1470
Bi-Metal Thermometers	1473
Carbon Monoxide Meters	487
Circuit Testers	1461

Clamp Meters

AC / DC.....	1466
Current Clamps.....	1461, 1466, 1468, 1540
True RMS.....	1460, 1466

Combustible Gas Detectors.....

	487
--	-----

Conductivity Meters.....

	1490
--	------

Digital Thermometers.....

	1473
--	------

Equipment Cases.....

	1461, 1464, 1471
--	------------------

Force Gauges.....

	1484
--	------

Hardness Testers

Non-Metals.....	1479
Steel & Alloys.....	1479

Heat Stress Meter.....

	645, 1475
--	-----------

Humidity Meters, Infrared.....

	1475
--	------

Hygrometers, Thermo.....

	1474, 1476
--	------------

Infrared Thermometers.....

	1469-1470
--	-----------

Inspection Cameras.....

Borescope.....	1376, 1485
	1485

Insulation Testers.....

	1467
--	------

Integral Probe Anemometers.....

	1486-1487
--	-----------

Laser Distance Kits.....

	1482
--	------

Laser Levels.....

	1461
--	------

LCR Meters.....

	1468
--	------

Light Meters, Digital.....

	1481
--	------

Manometers.....

	1487-1488
--	-----------

Moisture Meters.....

	1477
--	------

Motor Rotation Testers.....

	1468
--	------

Multimeters

AC/DC.....	1460, 1462
Electrical.....	1460
True RMS.....	1460

ORP Meters.....

	1490
--	------

pH Meters.....

	1490
--	------

Porosity Detectors.....

	1478
--	------

Pressure Gauges

Dry.....	1232, 1489
Liquid Filled.....	1489

Psychrometers.....

	1475
--	------

Refractometers.....

	1490
--	------

Sound Level Meters

Digital.....	440, 1480
Integral Probe.....	440, 1480-1481

Stem Thermometers.....

	1473
--	------

Stopwatches.....

	645, 1475, 1483
--	-----------------

Stroboscopes.....

	1483
--	------

Surface Mount Thermometers.....

	1473
--	------

Tachometers.....

	1482
--	------

Tally Counters.....

	1483
--	------

Temperature Probes.....

	1471, 1475
--	------------

Test Leads.....

	1463
--	------

Test Probes.....

	1463
--	------

Testers, Multi-Function.....

	1462
--	------

Thermal Cameras.....

	1470
--	------

Thermocouple Probes.....

	1471
--	------

Thermocouple Thermometers.....

	1429, 1471, 1474-1475
--	-----------------------

Thermometer / Hygrometers.....

	645, 1474-1476
--	----------------

Thickness Gauges.....

	1478-1479
--	-----------

Vane Anemometers.....

	1486
--	------

Vibration Meters.....

	1484
--	------

Voltage Testers.....

	1462
--	------

REELCRAFT

Cord Reels

Fluorescent.....	1532
Single Outlet.....	1532

Hose Reel Carts.....

	1237
--	------

Hose Reels.....

	1235-1237, 1532
--	-----------------

RELTON

Cutting Fluids

for all Metals.....	1148
for Aluminum.....	1148

Drill Bits

Masonry.....	1196
Splines-Shank.....	1196

Rotary Hammer Bits.....

	1195-1196
--	-----------

REMCO PRODUCTS

Scoops, Spill Control	687
------------------------------------	-----

Scrapers, Spill Control	687
--------------------------------------	-----

Shovels, Spill Control	686
-------------------------------------	-----

Squeegees	687
------------------------	-----

REMCON PLASTICS INCORPORATED

Lockers, Plastic	110
-------------------------------	-----

RICHARD

Blades, Packaging Knife	1440-1441
--------------------------------------	-----------

Flooring Knives	1441
------------------------------	------

Hawks	1053
--------------------	------

Knives

Drywall.....	1053
Packaging.....	1440

Linoleum Knives	1441
------------------------------	------

Mixers, Paint	1046
----------------------------	------

Paint Supplies, Accessories	1050
--	------

Putty Knives	1052
---------------------------	------

Razor Blades	1052
---------------------------	------

Roofing Knives	1441
-----------------------------	------

Rubber Cutting Knives	1441
------------------------------------	------

Sanders, Hand	1053
----------------------------	------

Sanding Blocks	1053
-----------------------------	------

Saws, Drywall	1053
----------------------------	------

Scrapers, Drywall	1052
--------------------------------	------

Spreaders, Adhesive	1053
----------------------------------	------

Trowels, Drywall	1053
-------------------------------	------

Utility Knives	1440-1441
-----------------------------	-----------

RIDGID

Chain Wrenches	1372
-----------------------------	------

Compound Leverage Wrenches	1372
---	------

Drain Augers	1375
---------------------------	------

End Wrenches	1373
---------------------------	------

Flaring Tools	1374
----------------------------	------

Hex Wrenches	1372
---------------------------	------

Inspection Cameras	1376, 1485
---------------------------------	------------

Offset Wrenches	1373
------------------------------	------

Spud Wrenches	1372
----------------------------	------

Straight Wrenches	1373
--------------------------------	------

Strap Wrenches	1372
-----------------------------	------

Toilet Augers	1375
----------------------------	------

Tubing Cutters	1374
-----------------------------	------

Wrenches, Pipe	1373
-----------------------------	------

RIEKE

Wrenches, Drum	250
-----------------------------	-----

RMP

Buckets	307
----------------------	-----

Carts, Janitorial	309
--------------------------------	-----

Degreasers

ROPAK

Pails 27

ROSS H. BARBER

Water Filters 1586

RUBBERMAID

Air Fresheners 321-322

Angled Brooms 290

Ashtrays 283, 285, 383

Bathroom Faucets 350

Broom & Mop Racks 286

Buckets 306-307

Cabinets, Storage 98, 381

Caddy, Waste Container 266

Carts

Janitorial 275, 309

Laundry 303

Changing Tables 348

Cones, Crowd Control 296, 308

Containers, Poly 27

Coolers, Containers 1586

Corn Brooms 289

Dollies

Drum 244, 266

Waste Container 266, 276-277

Dusters, Janitorial 294, 320

Dustpans 290, 296

Expandable Gates 309

Extension Poles 288, 292, 294

Filing Trays 1577

Floor Signs 308

Food Handling Containers 175

Frames, Dust Mop 294-295

Garbage Cans 266-270, 272-275, 383, 761, 1577

Hand Scrubbers 292

Hoppers, Self-Dumping 171

Ladder Trucks 134

Lids, Waste Container 266, 268, 272, 276-277

Liners, Waste Container 267, 269-270, 273, 285

Measuring Cups 317

Microfiber Cloths 294

Mops

Dust 295

Wet 294, 304, 306

Pads, Cleaning 294

Panel Trucks 158-159

Platform Trucks

Plastic Deck 156-158

Semi-Live Skids 158

Structural Foam Deck 157

Portable Scales 1494

Push Brooms 288, 290

Recycling Containers 276-277, 1577

Sanitary Napkin Receptacles 349

Sheds, Portable 381

Shelf Carts 168

Shop Carts 169

Stacking Bins 26

Stacking Racks 157

Stepstools, Polyethylene 136, 1549

Sweepers 286

Tilt Trucks 172

Toilet Auto Flush Adapter 350

Trades Carts 169

Utility Carts 168-169

Wagons 157

Wheelbarrows 172, 370

Wringers 294, 307

RUBBERSET

Extension Poles 1048

Paint Supplies

Brushes 1047-1048

Foam Rollers 1049

Roller Covers 1049-1050

Rollers 1049-1050

Trays, Paint 1050

RUPTURESEAL

Spill Control, Leak Seal 683

RUST STOP

Rust Removers 1014, 1146

RUST-OLEUM

Caulking Guns 1018, 1045

Cleats 872

Coating, Hydrophobic 1045

Floor Repair 1018, 1045

Marking Paint 1040

Marking Wands 1040

Paint

Acrylic 1044

Alkyd 1041, 1043

Antislip 1045

Applicator 1040

Epoxy 1043

Floor 1019, 1044-1045

High Heat 1042

Line Striping 1039

Marking 1038

Rubber 1045

Sprayers, Paint 1042

Striping Machines 1039-1040

SAFCO

Audio-Visual Carts 1560

Chair Caddies 1554

Coat Racks 1581

Coffee Equipment 1584

Computer Desks 1560

Desk Lamps 1582

Ergonomic Products, Seating 1547

Filing Cabinets

Lateral 1565

Oversized Files 1566

Vertical 1565

Footrests 1549

Hangers, Clothes 1581

Mail Sorters 1566

Paper Clamps, Hanging 1565

Recycling Containers 278

Suggestion Boxes 1581

Task Seating 1550, 1552

Whiteboards 1569

SAFEBLEND

Air Fresheners 314

Antimicrobial Soap 326

Carpet Cleaners 317

Detergents, Laundry 317

Dish Detergents 316

Disinfectants 314, 318, 759

Floor Cleaners 310-311

Floor Finishes 311

Floor Sealers 311

Floor Stripper 311

Glass Cleaners 315

Hand Cleaners, Lotion 315

Industrial Cleaners, Multi-Purpose 312

Soap Dispensers 315

SAFECROSS

Ammonia Inhalants 734

Antiseptics and Ointments 748

Body Lotions 749

Butterfly Wound Closures 742

Coagulants 761

Compresses 729-732, 734-735, 743, 750

Cotton Tip Applicators 729, 732, 747

CPR

Masks 729-730, 762

Shields 729-735, 762

Disposable Gloves 729-735, 762

Elastic Bandages 731, 740

Fabric Bandages 734, 740

Footwear Odour Neutralizers 750

Forceps 751

Gauze Bandages 729-735, 743

Hydrogen Peroxide 748

Insect Sting Relief 749

Isopropyl Rubbing Alcohol 748

Kits

Burn Care 753

First Aid 729-739

Literature, First Aid 729-730, 732-734

Ointments, Burn Care 749

Plastic Bandages 729-735, 741

Providine® Solution 748

Splints 731, 734, 754

Support Bandages 731-732, 746

Tongue Depressors 734, 747

Triangular Bandages 729-735, 747

Tweezers, First Aid 751

SAFETY SUPPORTS INC.

Automotive Stands 209

Work Stands 209

SAFETY WHIPS

Flagstaffs 856

SALISBURY BY HONEYWELL

Arc Flash Clothing

Coats 556

Coveralls 556

Hoods 556-557

Overalls 556

Arc Flash Clothing Kits 556-557

Faceshields 557

Gloves, High Voltage 558-559

SAMUEL ACME

Buckles

Plastic 1421

Stainless Steel 1420

Edge Protectors 1421, 1423

Strapping

Machines & Tools 1420-1421

Poly 1421-1422

Stainless Steel 1420

SANFORD CANADA

Monitor Stands 1577

SANITAIRE BY ELECTROLUX

Vacuums, Upright 360

SCEPTER

Containers, Poly 671

Jerry Cans 671-672

Transfer Pumps 671

BRAND INDEX

SCRUBS

Wipes.....334, 338

SEBA

Flashlights, Rechargeable.....1518
Floodlights.....1526
Hand Lamps.....1526

SHARPIE

Liquid Tip Markers.....846, 1445, 1578
Permanent Markers.....1445, 1578

SHIELD FOR FIRST AID

Blankets, Burn Care.....753
Kits, Burn Care.....753
Lip Balm.....335, 384
Sunscreen.....335, 384

SHOCKWATCH

Impact Labels.....1430
Temperature Labels.....1429

SHOP VAC

Air Filters.....359
Dollies, Waste Container.....271
Garbage Cans.....271
Lids, Waste Container.....271
Portable Blowers.....359
Shop Sweepers.....286, 358
Vacuums
Accessories.....357-359, 688
Back Pack.....357
Portable.....358
Wet / Dry.....354-357, 688

SHOWA BEST GLOVE

Chemical Resistant Gloves.....584, 586-587, 590, 592
Coated Gloves.....562, 566-567, 569-570, 572-573, 593
Cut Resistant Gloves.....575-576, 578, 581
Disposable Gloves.....595, 597, 599
Heat Resistant Gloves.....624

SHURLITE

Flint Lighters.....1073
Flints.....1073

SIGNATURE FENCING

Barricades, Traffic Control.....309, 867

SKETS SAFE

Insect Repellent.....335, 384

SKY HOOK

Sky Hooks.....199

SLICE

Blades, Packaging Knife.....1441
Utility Knives.....1441

SLIDE SLEDGE

Slide Hammers.....1365

SOPER'S

Blankets, Fire Resistant.....656

SOUTHWORTH

Lift Tables.....179, 181
Pallet Lifters.....181

SPAENAUR

Flux.....1145

SPG STORAGE PRODUCT GROUP

Reel Racks.....78
Shelving Units, Steel.....78

SPIC N SPAN

Floor Cleaners.....310

SPRAYON

Aerosol Can Disposal Systems.....1037
Anti-Spatter.....1147
Anti-Static Cleaners.....1007
Brake Cleaners.....1005
CFC Free Degreasers.....319, 1003, 1007
Coil Cleaner.....1005
Contact Cleaners.....1007
Dry Lubricants, Synthetic.....1009, 1012
Dusters, Aerosol.....319, 1007
Flash Free Degreasers.....1007
Food Grade Cleaners, Non-Flammable.....1004
Food Grade Degreasers.....1004, 1007
Galvanizing Compounds.....1146-1147
Glass Cleaners.....315, 1004
Graffiti Removers.....319, 1005, 1043
Industrial Cleaners, Multi-Purpose.....319, 1004
Layout Fluids.....1148
Machinery Oil.....1011
Penetrants, Multi-Purpose.....1013
Rust Converters.....1148
Spray Lubricants.....1008-1012, 1018
Stainless Steel Cleaners.....319, 1004
Stencil Inks.....799

SQWINCHER

Sqwincher®.....648-649
Water Coolers.....650

STACKBIN

Bins, Steel.....40-41
Stacking Bins.....40-41
Stacking Racks.....41

STAEDTLER

Pencils.....1578
Permanent Markers.....1578

STANLEY BOSTITCH

Carton Staplers.....1447
Staple Removers, Packaging.....1447
Staples, Carton Staplers.....1447

STANPRO

Bay Lights.....1520
Fixtures, Light.....1520
Floodlights.....1520

STEINEL CANADA INC.

Heat Guns.....1191

STI

Fire Protection, Fire Alarm Protectors.....654
Key Boxes.....654

STORCAN

Conveyors.....224-225

STOREX

Filing Boxes.....1564

STREAMLIGHT

Batteries, C Cell.....1515
Battery Chargers.....1515
Flashlights
12 V.....1513
AA Cell.....1512-1513, 1515
AAA Cell.....1512
C Cell.....1512-1513
Hazardous Locations.....1513
N.....1513
Pocket.....1512, 1515
Rechargeable.....1513, 1515-1516, 1518
Tactical.....1512
Waterproof.....1513
Headlights, Hard Hat.....419
Lanterns
Cordless.....1516
Waterproof.....1518
Penlights.....1512
Spot Lights.....1516

STRIKE FIRST CORPORATION

Extinguishers, Fire.....651

STRONG HOLD

Cabinets, Storage.....99, 101-102
Shelving Units, Stainless Steel.....99
Shop Desks.....102
Shop Tables.....102

STRONGARM

Auto Body Repair Kits.....208
Automotive Stands.....207
Axle Jacks.....206, 208
Dollies
Mechanic's.....209
Wheel.....208
Engine Stands.....208
Garage Jacks.....206

SUMNER

Jacks, Pipe.....1115
Pipe Flange Aligners.....1115
Pipefitting Levels.....1115

SUNBEAM

Air Filters.....1500
Air Purifiers.....1500
Humidifiers.....1500

SUNLIGHT

Dish Detergents.....316

SUNNEX INC

Task Lights.....1523

SWAN

Guns, Garden Hose.....377

SWINGLINE

Shredders, Paper.....1580

SYNETIK

Ergonomic Products, Seating.....	1554
Office Seating.....	1553
Task Seating.....	209, 1134, 1553

TANITA

Weighing Scales.....	1492
----------------------	------

TECHSTAR PLASTICS INC

Box Trucks.....	173-175
Casters.....	171
Food Handling Containers.....	175
Hoppers, Self-Dumping.....	171
Nesting Bins.....	18
Pallets, Plastic.....	48
Recycling Containers.....	278-279
Salt & Sand Containers.....	363
Stepstands, Steel.....	136
Tanks, Storage.....	27

TENSATOR

Cones, Traffic Control.....	863
Frames, Crowd Control.....	880
Posts, Crowd Control.....	876-879
Rope, Crowd Control.....	879
Rope Ends, Crowd Control.....	879
Security, Gates.....	878
Wall Plates, Crowd Control.....	877

THE ANDERSEN COMPANY

Anti-Fatigue Matting.....	902-903, 905
Entrance Matting	
Pile.....	888
Rubber.....	888

THE HARRIS PRODUCTS GROUP

Cable Connectors, Welding.....	1084
Cutting Attachments, Welding.....	1065
Cutting Tips.....	1065
Cutting Torches.....	1065
Fillet Gauges.....	1073
Flux.....	1141
MIG Pliers.....	1088
Outfits, Welding.....	1062
Regulators, Welding.....	1066
Torch Handles.....	1065

THE SAFETY ZONE

Aprons.....	529-531
Boot Covers.....	527
Hair Nets.....	526-527
Hoods, General Protection.....	527
Lab Coats, General Protection.....	531
Shoe Covers.....	527
Sleeves	
Polypropylene.....	528
Vinyl.....	528

THERMO-HEAT

High Visibility Clothing, Hat/Toque.....	549
--	-----

THERMOID

Acetylene Hoses, Welding.....	1075
Gas Hoses, Welding.....	1075
Oxygen Hoses, Welding.....	1075

TILLSON BRANDS

Salt & Sand Containers.....	363
Scoops, Polyethylene.....	363

TILTWATCH

Handling Labels.....	1430
----------------------	------

TOPRING

Adjusting Valves.....	1232
Chucks, Air.....	1224
Cut-Off Tools, Air.....	1256
Desiccant Systems.....	1251, 1257
Drains, Air.....	1257
Filter/Regulator/Coalescing Filters.....	1257-1258, 1260
Filter/Regulator/Lubricators.....	1255, 1258-1259
Filter/Regulators	1255-1256, 1259
Guns	
Air.....	1225-1227, 1230
Sandblasting.....	1225
Hose Fittings.....	1234, 1247, 1250
Hose Reels.....	1234-1235
Hose Whips.....	1250
Hoses, Air.....	1234
In-Line Filters.....	1251, 1256
In-Line Lubricators.....	1251, 1256, 1261
In-Line Regulators.....	1232, 1256, 1261
Manifolds, Air.....	1250
Non-Sparking Tools, Wrenches.....	1256
Pneumatic Pipe Fittings.....	1247
Pneumatic Tube Fittings.....	1248
Pressure Gauges, Tire.....	1224
Quick Couplers.....	1246, 1248-1250
Tire Inflator Gauges.....	1224
Tire Pressure Gauges.....	1224
Vacuums, Accessories.....	1225
Valves, Safety.....	1232, 1257

TORK

Hand Towels.....	341
Paper Towel Dispensers.....	341-343
Paper Towels.....	341-344, 346
Toilet Paper.....	346
Toilet Paper Dispensers.....	346-347
Wipes.....	339
Wipes Dispensers.....	339

TRACTEL

Hoists, Manual.....	199
---------------------	-----

TRAMEX

Moisture Meters.....	1477
----------------------	------

TREND-PAK

Postal Tubes.....	1434
-------------------	------

TRI LITE MARS

Dock Lights	
Double Strut.....	219
Flexible.....	218-219
Incandescent.....	219
Single Strut.....	219
Stop & Go.....	220
Halogen Lamps / Light Bulbs.....	219
LED Lamps / Light Bulbs.....	219

TRI-ARC MANUFACTURING

Rolling Ladders.....	138-140
----------------------	---------

TRI-FLOW

Spray Lubricants.....	1008, 1010
-----------------------	------------

TRIPP LITE

Power Strips, GFCI.....	1542
UPS Systems.....	1542

TRUE TEMPER

Wheelbarrows.....	370
-------------------	-----

TRUMETER

Measuring Counters.....	1484
Measuring Wheels.....	1278, 1482, 1484
Ratchet Counters.....	1483

TUFF TIE

Cable Ties.....	1435
-----------------	------

TYDEN BROOKS

Tamper Seals.....	1451
-------------------	------

TYROLIT

Cut-Off Wheels.....	912, 914
Flap Discs.....	919
Grinding Wheels, Type 27.....	912, 916

ULTRATECH

Berms, Spill Control.....	681
Cable Protectors, Office.....	218
Drain Protectors.....	682
Drain Seals.....	681-682
Drum Equipment, Spill Pallets.....	704-705, 710
Shovels, Spill Control.....	686

UNION BUTTERFIELD

Countersinks.....	962
Hand Taps.....	956-957
Screw Extractors.....	960
Tap Wrenches.....	960

UNIROPE

Slings, Nylon.....	188
--------------------	-----

URBAN IMAGES

Salt & Sand Containers.....	363
-----------------------------	-----

UTICA

Torque Screwdrivers.....	1329
--------------------------	------

UVEX BY HONEYWELL

Faceshields.....	411
Glasses, Safety.....	391-396
Goggles, Safety.....	404-406, 1120
Solutions, Lens Cleaning.....	409
Stations, Lens Cleaning.....	409
Tissues, Lens Cleaning.....	409

VALLEYCRAFT

Dollies, Drum.....	244, 702
Lifters, Drum.....	238
Pallets, Plastic.....	46
Shelf Carts.....	161
Workbenches, Folding.....	121

VENREZ

Stacking Chairs.....	1555
----------------------	------

VERTEX STANDARD

Two-Way Radios.....	442
---------------------	-----

BRAND INDEX

VESTIL

Agricultural Jacks.....	207
Bollards.....	87
Dollies	
Drum.....	244
Mechanic's.....	209
Polyethylene.....	177
Wheel.....	177
Extensions, Forklift.....	187
Lift Tables.....	178, 181
Lifters, Drum.....	242-243
Machinery Rollers.....	205
Openers, Pail.....	250
Pallet Trucks.....	186
Pallets, Aluminum.....	48
Pry Dollies.....	177
Security, Gates.....	216
Shelving Units, Stainless Steel.....	78
Stairway Ladders.....	140
Sweepers.....	286
Wire Spool Carts.....	167
Work Positioners.....	181

VIBRASYSTEMS

Anti-Vibration Pads.....	1272
Cupmounts.....	1272
Isolators, Vibration.....	1272
Leveling Mounts.....	1272

VIKING

Flame Resistant Clothing, Rainwear.....	542, 548
Flame Retardant Clothing, Jackets.....	542, 548
High Visibility Clothing	
Jackets.....	547-548
Pants.....	548
Parkas.....	547
Sweatshirts.....	547
T-Shirts.....	547
Vests.....	546-547
Hoods, Rain.....	542, 548
Jackets, Rain.....	542, 551
Overalls, Rain.....	542
Pants, Rain.....	551-552
Parkas.....	552
Seat Cover, Automotive.....	546
Vests, Traffic Control.....	545-546
Work Boots.....	633

WAGNER

Guns, Air.....	1051
Sprayers, Paint.....	1051

WALTER SURFACE TECHNOLOGIES

Anti-Spatter.....	1147
Cutting Fluids	
for all Metals.....	1148-1149
for Steel.....	1148
Degreasers, Multi-Purpose.....	319, 1003
Food Grade Degreasers.....	1004

WATERLOO

Tool Storage	
Boxes.....	1394
Cabinets.....	1395
Chests.....	1394-1395

WD-40

3-in-1.....	1012
Dry Lubricants, Silicone.....	1010
Engine Degreasers.....	1015
Spray Lubricants.....	1011, 1018
WD-40®.....	1004, 1013

WEARWELL

Anti-Fatigue Matting.....	891-894, 896-897, 899-900, 905, 907
Anti-Static Matting.....	560, 903-904
Entrance Matting	
Rubber.....	888
Vinyl.....	901
Eyewash Stations, Matting.....	727, 893
Grounding Mats.....	904
Matting, Welding.....	904, 1119

WELD-AID

Anti-Spatter.....	1143
-------------------	------

WELDCOTE METALS

Brazing Alloys.....	1139
Flux.....	1141
MIG Wire	
Bronze.....	1138
Copper.....	1138
Steel.....	1135, 1137
Plasma Cutter Guides.....	1069
Solder.....	1140
Stick Electrodes.....	1136-1137, 1139
TIG Rods.....	1136-1138, 1140

WELDCRAFT

Air (Gas) Cooled Torches.....	1101
Alumina Nozzles.....	1104-1106
Back Caps, TIG Torch.....	1108
Collet Bodies, TIG Torch.....	1107-1109
Collets, TIG Torch.....	1105-1109
Gas Hoses, Welding.....	1110
Insulators, TIG Torch.....	1108
Lava Nozzles.....	1105
Power Cable Adapters, TIG Torch.....	1109
Power Cables, TIG Torch.....	1110
Water Cooled Torches.....	1103-1105
Water Hoses, Welding.....	1110

WELD-MATE

Air (Gas) Cooled Torches.....	1101
Alumina Nozzles.....	1106
Aprons, Leather.....	1132
Back Caps, TIG Torch.....	1108
Beanies, Welding.....	1133
Bibs, Leather.....	1132
Blankets, Welding.....	1118
Cable Connectors, Welding.....	1084-1085
Cable Lugs, Welding.....	1085
Cable Protectors, Welding.....	1110
Casters.....	1119
Chaps, Welding.....	1132
Chipping Hammers, Welding.....	1087
Collet Bodies, TIG Torch.....	1107-1108
Collets, TIG Torch.....	1107
Conductor Tubes, MIG Gun.....	1096
Contact Tips, MIG Gun.....	1094-1097
Cutting Tips.....	1070-1071
Diffusers, MIG Gun.....	1095-1097
Electrode Holders.....	1084
Flint Lighters.....	1073
Flints.....	1073
Gas Hoses, Welding.....	1110
Gloves, Welding.....	619-621, 1129-1131
Goggles, Welding.....	1120
Gouging Electrodes.....	1087
Gouging Torches.....	1087
Ground Clamps, Welding.....	1086
Hand Pads.....	621, 1131
Head Assemblies, MIG Gun.....	1095
Helmets, Welding.....	1123
Insulators, TIG Torch.....	1108
Jackets, Leather.....	1132
Lava Nozzles.....	1105
Liners, MIG Gun.....	1095-1097

Magnifier Plates.....	1128
MIG Guns.....	1094-1096
MIG Pliers.....	1088
MIG Wire, Steel.....	1135
Nozzle Reamers.....	1088
Nozzles, MIG Gun.....	1095-1097
O-Rings, MIG Gun.....	1095
Power Cable Adapters, TIG Torch.....	1109
Power Cables, TIG Torch.....	1110
Pressure Gauges, Dry.....	1068
Retaining Rings, MIG Gun.....	1095
Rod / Electrode Containers.....	1089, 1134
Scratch Brushes.....	947, 1087
Screens, Welding.....	1119
Sleeves, Welding.....	1132
Soapstone.....	1143
Spats, Welding.....	1132
Squares, Welding.....	1086
Sweatbands.....	420, 1133
Tip Cleaners.....	1073
Tip Refacers.....	1073
Triggers, MIG Gun.....	1095
Water Cooled Torches.....	1103
Water Hoses, Welding.....	1110

WELLER

Butane Torches.....	1080
Soldering Guns.....	1080-1082
Soldering Irons.....	1080-1082
Soldering Stations.....	1082

WESCO

Extensions, Forklift.....	242
Gauges, Drum.....	251
Hand Trucks.....	149-151
Lift Tables.....	179, 184
Lifters, Drum.....	238-239, 242-243
Pallet Lifters.....	184
Pallet Trucks.....	185-186
Stackers.....	180
Trucks, Drum.....	247

WESTCOTT

Clipboards.....	1579
-----------------	------

WESTERN ENTERPRISES

Flashback Arrestors.....	1074
Hose Repair Kits, Welding.....	1075
Propane Torches.....	1064
Quick-Connects, Welding.....	1074
Y Connections, Hose.....	1074

WHITE LIGHTNING

Caulk.....	1025
Sealants, Silicone.....	1025

WILTON

Angle Vises.....	1295
Bar Clamps.....	1287
Bench Vises.....	1294
C-Clamps.....	1289
Drill Press Vises.....	1295
Machine Vises.....	1295
Quick Clamps.....	1288
Tilting Vises.....	1295

WINDEX

Glass Cleaners.....	315
---------------------	-----

WIPECO

Paint Supplies	
Accessories.....	1054
Cloths.....	1054
Drop Sheets.....	1054
Rags.....	338, 1054

WISS

Fabric Shears.....	1357
Hand Crimpers, HVAC.....	1359
Hand Seamers, HVAC.....	1359
Nippers, End Cut.....	1357
Scissors	
Electrician.....	1357
General Purpose.....	1356
Industrial.....	1356-1357
Shears, Industrial.....	1356
Snips	
All Purpose.....	1357-1359
Duckbill.....	1357
Grape & Orchard.....	1357
Metal Cutting.....	1358-1359

WMH TOOL GROUP INC.

Bar Clamps.....	1284
------------------------	------

WOBBLELIGHT

Task Lights.....	1529
-------------------------	------

WOODHEAD CANADA LTD

Tool Balancers.....	203
----------------------------	-----

WORKSMAN

Tricycles.....	161
-----------------------	-----

WORLD DRYER

Hand Dryers.....	351
-------------------------	-----

ZENITH SAFETY PRODUCTS

Absorbents.....	684-685, 691-692
Anti-Fatigue Matting.....	894, 902
Anti-Skid Tape.....	872
Anti-slip Snow Shoes.....	636
Aprons.....	530, 533
Arm / Leg Bands, Traffic Control.....	548
Back Supports.....	641

Barricade Tape.....	868
Barricades, Traffic Control.....	83, 867, 874
Bars, Traffic Cone.....	863
Base, Crowd Control.....	874
Battery Acid Neutralizers.....	686
Blankets, Fire Resistant.....	656
Booms, Spill Control.....	679
Boot Sanitizer.....	907
Chemical Resistant Gloves.....	583-584, 586-588, 590-592
Circular Saws, Framing.....	872
Clean Room Matting.....	907
Cleats.....	872
Coated Gloves.....	562-568, 570-574, 578, 591-592, 627-628
Cones, Traffic Control.....	862
Convex Mirrors.....	882
Coveralls, General Protection.....	532-533, 689-693, 697
Cut Resistant Gloves.....	575, 613
Delineators, Traffic Control.....	863
Disposable Dust Masks.....	447
Disposable Gloves.....	594-595, 597-600
Disposable Respirators.....	447
Dollies, Drum.....	244, 702
Dome Mirrors.....	881, 883
Drain Protectors.....	682
Drain Seals.....	682
Drip Pans.....	252, 680
Entrance Matting	
Rubber.....	888
Vinyl.....	901
Ergonomic Products, Gloves.....	601
Face Mask.....	447
Flame Resistant Clothing, Rainwear.....	541
Flat Mirrors.....	882
Folding Gates.....	83, 309, 867
Foot Guards	
Plastic.....	637
Steel.....	637
Glasses	
Cases.....	407
Cord Retainers.....	408
Safety.....	386-390
Gloves	
Canvas Cotton.....	628
Cotton.....	612
Goggles, Safety.....	404, 412, 689-697
Hair Nets.....	526
Hard Hats.....	418
Harnesses, Traffic Control.....	548
Hazardous Materials Cabinets.....	658
Heat Resistant Gloves.....	623-624
High Visibility Clothing	
T-Shirts.....	547
Vests.....	545
Inspection Gloves.....	625

Jersey Gloves.....	628-629
Kits, Spill Control.....	689-698
Knit Gloves.....	626
Lab Coats, General Protection.....	532-533
Leather Gloves.....	608-613, 618
Megaphones.....	444
Neutralizers, Spill Control.....	686, 697
Pads, Spill Control.....	673-678, 680
Parking Curbs, Traffic Control.....	861
Pillows, Spill Control.....	680
Posts, Crowd Control.....	874-875
Rag Rugs, Spill Control.....	679
Rolls, Spill Control.....	673-678, 689-690
Scoops, Polypropylene.....	694
Shoe Covers.....	527
Sleeves	
Cotton.....	528
Vinyl.....	528
Socks, Spill Control.....	680
Solutions, Lens Cleaning.....	409
Speed Bumps, Traffic Control.....	860
Stations, Lens Cleaning.....	409
Suits, Rain.....	540
Toe Guards.....	637
Towellettes, Lens Cleaning.....	409, 465, 760
Vests, Traffic Control.....	545
Waiter's / Parade Gloves.....	625
Wall Plates, Crowd Control.....	875
Winter Lined Gloves.....	549, 571, 609, 611, 613-618
Winter Liners.....	418, 553

ZIPWALL

Paint Supplies	
Wall Barriers.....	1054

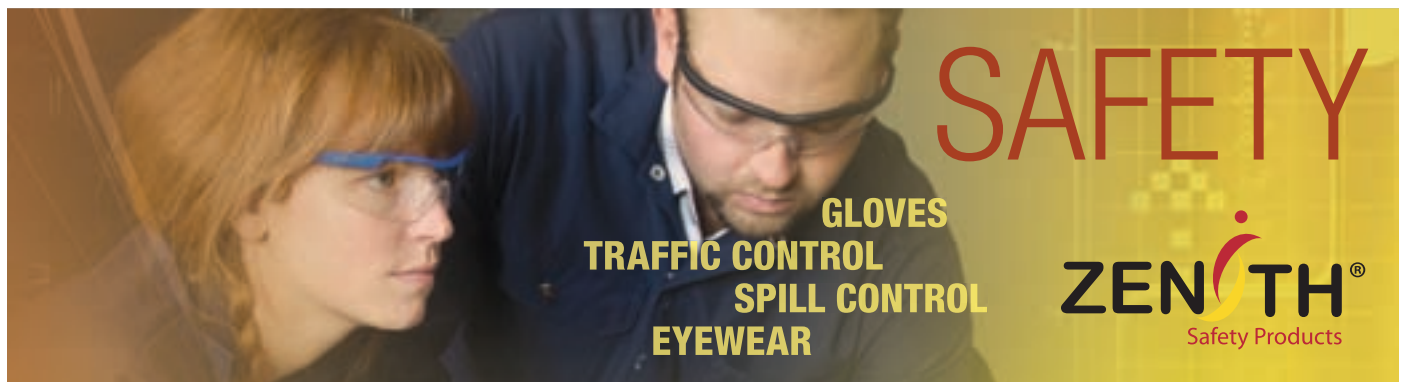

-A-

Abrasives

Backing Pads.....	921-922, 925, 927, 935
Benchstand Belts.....	929
Bristle Brushes.....	921, 1271
Bristle Discs.....	921
Buffing Compounds.....	937
Buffing Wheels.....	937
Cartridge Rolls.....	929
Crimped Filament Wheels.....	912-913
Cup Brushes.....	945
Cut & Polish Wheels.....	938
Cut-Off Wheels.....	912-916
Deburring Wheels.....	936, 938, 1271
Disc Holder Pads.....	922-925, 927, 935-936, 938
End Brushes.....	940, 942, 944
Files.....	1302-1307
Finishing Wheels.....	938
Flap Brushes.....	937
Flap Discs.....	918-919
Flap Wheels.....	919-920, 937
Grinding Wheels.....	912-917, 1271
Grip-On Discs.....	926
Portable Belts.....	928
Portable File Belts.....	928
Rasps.....	1305
Resin Fibre Discs.....	922-923, 925
Rolo™ / Power-Lock Discs.....	924-925, 935
Sanding Sponges.....	933
Sandpaper.....	930-932
Scratch Brushes.....	946-947, 1087
Spiral Bands.....	929
Stick-On Discs.....	926-927
Surface Conditioning Belts.....	937
Surface Conditioning Discs.....	934-936, 938
Surface Conditioning Pads.....	302, 933-934, 938
Surface Conditioning Rolls.....	930, 933-934
Tube Brushes.....	945
Wheel Brushes.....	941-944, 1271
Absorbents	684-685, 691-692
Accelerators, Adhesive	1032
Accident Prevention Tags	786-788, 790
Acetaminophen	752
Acetone	1037
Acetylene Hoses, Welding	1075
Acrylic Coating	1040, 1042-1044
Acrylic Paint	1040, 1042-1044
Adapters, Power Cable	1109
Adaptors, Pipe Thread	1240
ADF Filters	1121, 1124-1126
Adhesive Bandages	741
Adhesives	
Accelerators.....	1032
Acrylic.....	1034
All Purpose.....	1023
Carpenters' Glue.....	1029
Caulk.....	1025
Caulking Guns.....	1018, 1023-1024, 1035, 1045, 1161
Construction & Floor.....	1029
Contact Cement.....	1029
Epoxies.....	1020-1021, 1023, 1033-1034
Epoxy Applicators.....	1021, 1035
Floor Repair.....	1018-1019, 1045
Floor Sealers.....	1019
Glue Guns.....	1035-1036, 1418
Glue Sticks.....	1036, 1418
Instant.....	1031-1032
Pipe Cements.....	1022
Plumbers' Putty.....	1022
Primers.....	1032
Spray.....	1036, 1418
Spreaders.....	1053
Structural.....	1032-1034
Tape.....	1020, 1415
White Glue.....	1029
Wood Glue.....	1029
Adjustable Reamers	985

Adjustable Wrenches	1309-1312, 1330, 1332
Adjusting Valves	1232
Admittance Signs	803-810, 813
Aerosol Can Disposal Systems	1037
Agricultural Jacks	207-208
Air (Gas) Cooled Torches	1101, 1103-1104
Air Conditioners	1500
Air Filters	359, 1058, 1500, 1506
Air Fresheners	314, 321-322
Air Operated Pumps	258
Air Products	
Adjusting Valves.....	1232
Air Dryers.....	1251, 1257
Ball Valves.....	1231
Butterfly Valves.....	1231
Chucks.....	1224
Compressors.....	1262-1265
Cut-Off Tools.....	1204
Drains.....	1257
Filters.....	1251, 1255-1260
Guns.....	1035, 1051, 1225-1230
Hose Fittings.....	1234, 1239, 1247, 1250
Hose Reel Carts.....	1237
Hose Reels.....	1076, 1234-1237, 1532
Hose Whips.....	1250
Hoses.....	1207, 1233-1235
In-Line Regulators.....	1232, 1256, 1261
Lubricators.....	1251, 1256, 1261
Manifolds.....	1250
Pipe Fittings.....	1228, 1240-1244, 1247
Piping.....	81
Pressure Gauges.....	1058, 1224
Quick Couplers.....	1207, 1233, 1246, 1248-1250
Safety Valves.....	1232, 1257
Tire Inflator Gauges.....	1224
Tube Fittings.....	1239, 1248
Tubing.....	1239
Air Purifiers	1500
Air Quality Monitors	487, 1474
Air Tool Oil	1037, 1261
Air Tools	
Buffers.....	1221
Chippers.....	1088, 1207, 1213
Drills.....	1205, 1209, 1221-1223
Engravers.....	1212, 1223
Grinders.....	1204, 1211-1212, 1215, 1220, 1222-1223
Hammers.....	1213
Sanders.....	1207, 1211-1213, 1216-1221
Saws.....	1214
Scalers.....	1207, 1214
Screwdrivers.....	1207, 1209, 1211, 1222
Shears.....	1214
Wrenches.....	1205-1206, 1208, 1210, 1214, 1222
Aircraft Cables	194
Airport Windsocks	871
Airway Kits	763
Aisle Marking Tape	869-870
Aisle Signs	12, 48
Alarms, Smoke	655
Aligners, Pipe Flange	1115-1116
Aligning Punches	1369
Alkyd Coating	1040-1041, 1043-1044
Alkyd Paint	1040-1041, 1043-1044
Alligator Clips	1460, 1463
Alloys, Brazing	1139
Alumina Nozzles	1104-1106
Aluminized Gloves	624
Aluminum Cleaners	1145
Aluminum Foil	1583
Aluminum Foil Tape	1020, 1415
Ambient Air Pump Respirators	466, 481, 1127
Ammonia Inhalants	734, 763
Anchorage Connectors	516-517, 519
Anchors	
Beam Clamp.....	517
Cross-Arm Strap.....	519, 560
D-Bolt.....	516, 519
Friction Bolt.....	516

Anemometers	
Integral Probe.....	1486-1487
Vane.....	1486
Angle Clamps	1285
Angle Drills	
Air.....	1222
Electric.....	1184
Angle Grinders	
Air.....	1204, 1211, 1215, 1222
Electric.....	916, 1163, 1168-1171
Angle Vises	1295
Angle Wrenches	1335
Angled Brooms	290
Annular Cutters	972, 1193
Antibacterial Soap	324-325, 329, 332
Antibacterial Wipes	318, 465, 759-760
Anti-Fatigue Matting	891-909
Anti-Freeze	1144
Anti-inflammatory	752
Antimicrobial Soap	326
Anti-Seize	1016
Antiseptics	
Benzalkonium Towelettes.....	729-735, 748
Dettol™.....	748
Hydrogen Peroxide.....	734, 748, 759
Isopropyl Rubbing Alcohol.....	748
Providine® Solution.....	748
Antiseptics and Ointments	729-732, 745, 748-749
Anti-Skid Cleats	872
Anti-Skid Tape	872-873
Antislip Floor Coating	1045
Anti-Slip Floor Coatings	873, 1019
Antislip Floor Paint	1045
Anti-slip Snow Shoes	636
Anti-Spatter	1143, 1145, 1147
Anti-Static Cleaners	1007
Anti-Static Matting	560, 903-904
Anti-Vibration Gloves	606-607
Anti-Vibration Hammers	1364-1365
Anti-Vibration Pads	1272
Appliance Trucks	150, 1454
Aprons	
Chemical Resistant.....	530-531, 533
General Protection.....	529, 534
Heat Resistant.....	551
Leather.....	1132
Limited Use.....	530-531, 533
Tool.....	1391
Welding.....	1132
Arbor Presses	208
Arbors, Hole Saw	1193, 1198
Arc Flash Clothing	
Coats.....	556
Coveralls.....	554-556
Hoods.....	556-557
Jackets.....	555
Overalls.....	555-556
Pants.....	554
Shirts.....	554
Arc Flash Clothing Kits	556-557
Arc Rated Harness	500, 560
Arc Rated Lanyards	510, 560
Archive, Shelving	57
Arm, Splints	731, 734, 754
Arm / Leg Bands, Traffic Control	548
Arrestors, Welding Torch	1074
Ashtrays	236, 283-285, 383, 657
Audio-Visual Carts	1560-1561
Auger Bits	1199
Augers	
Drain.....	1375
Toilet.....	1375
Auto Body Repair Kits	208
Auto-Ignite Torches	1064
Automatic Brake Winches	195
Automotive	
Carburetor Cleaner.....	1015
Windshield De-Icer.....	1015
Automotive Cleaners	
Diesel Conditioner.....	1015
Automotive Seat Cover	280, 546
Automotive Stands	207, 209

Axes	
All-Purpose.....	368
Carpenter.....	368
Axial Blowers	488-489
Axle Jacks	206, 208
-B-	
Back Caps, TIG Torch	1108
Back Supports	641-642
Backboard, Spinal	755
Backing Pads	921-922, 925, 927, 935
Backpack, Hydration	647
Bag Sealing Tape	1436
Bags	
Garbage.....	278, 280-282, 348-349, 383, 761
Laundry.....	303
Paper.....	1435
Poly.....	1436
Static.....	1435
Tire.....	280
Tool.....	1391-1393, 1464
Balaclavas	553
Balancers, Tool	203
Ball Pein Hammers	
Anti-Vibration.....	1365
Fiberglass Handle.....	1365
Non-Sparking.....	1380
Wood Handle.....	1309-1310, 1312, 1362, 1365
Ball Valve Lockouts	780, 782-784
Ball Valves	1231
Balometers	1488
Bandages	
Adhesive.....	741
Butterfly Wound Closures.....	742
Compresses.....	729-730, 734-735, 743, 746
Elastic.....	731, 740, 746
Fabric.....	734, 740-742, 745
Gauze.....	729-735, 743
Plastic.....	729-735, 741-742, 745
Plastic Strips.....	734, 742
Self-Stick.....	742, 746
Spray.....	742
Support.....	731-732, 746
Transparent.....	741
Triangular.....	729-735, 747
Wound Closures.....	742, 745
Banding Film	1425
Bands	
Hearing.....	430-431
Spiral.....	929
Bandsaws	
Metal Cutting.....	1178
Wood Cutting.....	1178
Bankers® Boxes	1564
Banners, Traffic Control	859
Bar, Grab	350
Bar Clamps	1284-1287
Bar Magnets	1298
Bar Racks	53
Barricade Tape	868
Barricades, Traffic Control	83, 309, 867, 874
Bars	
Cargo.....	212, 1457
Crowbars.....	368, 1380
Jack.....	1457
Pinch.....	1367, 1380
Power.....	1541
Pry.....	1309-1312, 1340, 1366-1367, 1380, 1386
Rolling Head.....	1367
Traffic Cone.....	863
Wrecking.....	1366
Base, Crowd Control	874
Basins	731, 734, 751, 758
Baskets, Dipping	992
Bathroom Faucets	350
Bathroom Mirrors	350
Baths, Eye	728, 734

Baton Light858, 860	Drill948-955, 963-972,1193, 1196, 1198-1199	Boxes	Bushings, Pipe Thread1240, 1243
Batteries	Forstner1199-1200	Corrugated Paper1431	Butane Torches1080, 1083
1.5 Volt.....1507	Hammer1195-1196	Filing.....1564	Butterfly Valve Lockouts783
12 Volt.....1507, 1522	Hex1344	Jobsite.....36, 1394, 1401-1407	Butterfly Valves1231
3 Volt.....1507, 1515	Hex Square Drives1340, 1343	Key.....654	Butterfly Wound Closures742
6 Volt.....223, 1470, 1507, 1517, 1522	Nutsetters1343	Mailboxes.....1576	
9 Volt.....655, 1507	Posidriv®1345	Mailers.....1434	
AA Cell.....419, 444, 1507,1509, 1511-1512, 1514-1519,1529, 1572-1574	Prentice969-970	MSDS.....667	
AAA Cell.....1507, 1509-1510, 1519, 1572	Rotary Hammer1195	Outlet.....1539	
C Cell.....444, 1507, 1515-1516, 1518	Slotted1344-1345	Suggestion.....1581	
Cordless Power Tools.....1156-1164, 1167	Square Recess1344-1345	Tool Storage.....1309-1311, 1393-1394	
D Cell.....866, 1507, 1509-1510, 1517-1518	Torque1343	Braces, Tennis Elbow643	
Battery Acid Neutralizers686, 1037	Torx®1343-1344	Brackets, Gas Cylinder1079	
Battery Chargers1167, 1507, 1515	Tri-Wing1344	Brake Cleaners1005, 1015	
Cordless Drill.....1167	Blacksmiths' Hammers1366	Brakes, Caster231	
Flashlight.....1515	Blade Disposal Case1438	Brass Hammers1365	
Battery Cleaners1015	Blades	Brass Tags793	
Battery Coolant Checkers1490	Circular Saw.....914, 1202-1203	Brazing Alloys1139	
Battery Equalizers1037	Combination Saw.....1203	Brazing Tips1064	
Bay Lights1520	Cut-Off.....1203	Breaker Hammers1187	
Beaded Chain794	Mitre Saw.....1203	Brick Hammers1364	
Beam Clamp Anchors517	Packaging Knife.....1425, 1430, 1434, 1438-1442	Bristle Brushes921, 1271	
Beam Clamps199, 519	Razor.....1052	Bristle Discs921	
Beam Trolleys190, 519	Reciprocating Saw.....1201	Broadcast Spreaders364, 370	
Beams, Decking & Shoring212, 1457	Blank Tags791-793, 1448	Broom & Mop Racks286	
Beanies, Welding1125, 1133	Blankets	Brooms	
Bearing Greases1017	Burn Care.....753	Angled.....290	
Belt Dressing1012	Emergency.....756	Corn.....289-290	
Belt Holsters, Flashlight1509-1511	Fire Resistant.....656, 753	Magnetic.....290	
Belt Sanders	First Aid.....729, 732, 756-757	Push.....287-290, 301	
Air.....1213, 1216-1217, 1220-1221	Moving.....1454	Spill Control.....687	
Electric.....1180	Welding.....1118	Switch.....290	
Belts	Blast Cabinets1056-1057	Water.....377	
Benchstand.....929	Bleach314	Brushes	
Portable.....928	Blood Pressure Monitors756	Acid.....1141, 1145	
Portable File.....928	Blow Guns1225-1227, 1230	Boot & Shoe.....291, 889	
Surface Conditioning.....937	Blowers	Bristle.....921, 1271	
Tool.....1389	Axial.....488-489	Cup.....945	
Bench Cans992	Centrifugal.....489	End.....940, 942, 944	
Bench Grinders917, 1270	Portable.....359, 488, 1059-1060	Flap.....937	
Bench Scales1433, 1491-1495	Boards, Directory1569	Fountain.....799	
Bench Vises1293-1294	Body Lotions749	Maintenance.....26, 300-301, 1383, 1386	
Benches	Bollards54, 85, 87, 865	Paint.....1046	
Locker Room.....108, 382	Bolt Cutters1360-1361	Parts Cleaning.....993	
Packaging.....1433	Bolt Holder Pliers1349	Pot.....26, 301	
Park.....380	Bolt Removal Penetrants1013	Scratch.....946-947, 1087	
Service.....123-125	Bolts	Scrub.....26, 291, 300, 946	
Shipping.....1433	Carriage.....85, 89	Snow.....364	
Work.....103, 112-117, 120-123, 125, 1432	Eye.....194	Toilet Bowl.....349	
Benchstand Belts929	Bonding & Grounding Wires252-253, 665	Tube.....945	
Benzalkonium Towelettes729-735, 748	Bookcases1567	Vehicle.....292	
Berms, Spill Control681, 711-712, 714	Booms	Wheel.....941-944, 1271	
Bevels1280-1281	Jib.....201	Whitewash.....292	
Bibs	Spill Control.....679	Window.....292	
Leather.....1132	Booster Cables1542	Bubble Mailers1435	
Welding.....1132	Boot, Decontamination907	Bubble Pouches1435	
Bicycle Racks379	Boot & Shoe Cleaners889	Bubble Wrap1427	
Bi-Metal Thermometers1473	Boot Brushes291, 889	Buckets305-307	
Bin Carts7-8	Boot Covers289, 527, 534, 632, 889	Buckles	
Bin Racks8-9, 11, 39, 121	Boot Sanitizer907	Plastic.....1421-1422	
Bin Shelves6, 11, 15-17, 21, 59-60	Boot Trays889	Poly.....1422	
Bin Support Panels7	Boots	Stainless Steel.....1420	
Binders1579	Chemical Resistant.....631	Steel.....1421	
MSDS.....849	Knee.....631-632	Buffers, Air1221	
SDS.....849	Waders.....633	Buffing Compounds937	
Bins	Winter.....635-636	Buffing Wheels937	
ESD.....25	Work.....632-633	Bump Caps415, 417	
Mobile.....6	Borescope, Inspection Cameras1485	Bump Guard, Forklift186	
Nesting.....18-19, 26	Bottle Jacks206	Bumpers, Dock213	
Revolving.....29	Bottles	Bung Wrenches250	
Shelf.....13-15, 25	Dispenser.....672	Bungee Cords1455, 1457	
Small Parts.....11, 25, 31, 39	Storage.....28	Burn Care	
Stacking.....4-6, 13-14, 16-17, 21, 26, 40-41	Box Sealing Tape1410-1411, 1413, 1429	Blankets.....753	
Stacking Container.....4	Box Sealing Tape Dispensers1411, 1429	Creams.....749	
Steel.....40-41, 44-45	Box Trucks166, 172-175	Dressings.....732, 753	
Wire Mesh.....4	Box Wrenches	Gels.....753	
Bit Holders1343	15 Degree Offset.....1336	Kits.....753	
Bits	25 Degree Offset.....1336	Ointments.....749	
Auger.....1199	45 Degree Offset.....1336	Sheets.....753	
Core.....1194	Geared.....1331	Burning Guides1117	
Cross-Point / Phillips®.....1345		Burnishing Pads362	
		Burs, Carbide990-991, 1215	



Cabinet Carts660, 662	Cabinet Drawers37	Cabinet Tables124	Cabinet Tip Screwdrivers1309-1312, 1338-1340, 1383
Cabinets	Acid / Corrosives.....658, 664-666	Computer.....1559-1560	Drum.....663, 665
Extinguisher.....653	Filing.....1562-1563, 1565-1566	First Aid.....739	Flammables.....658, 660-662, 665, 667
Gas Cylinder.....1077	Key.....1570	Paint and Ink.....658, 662-663	Small Parts.....30-34, 37-38, 42-43, 45
Storage.....9-10, 35, 94-103, 381, 1561, 1563	Tool Storage.....103, 1309, 1312, 1395-1400	Cable Connectors, Welding1084-1085	Cable Cutters
Industrial Grade.....1085, 1349-1352, 1361	Insulated.....1377	Cable Lockouts779	Cable Lugs, Welding1085
Cable Protectors	Dock.....217	Office.....218, 1540	Welding.....1110
Cable Tie Tools1452	Cable Ties793-794, 1435, 1452	Cable Tracers1468, 1543	Cables
Aircraft.....194	Booster.....1542	Welding.....1085	Caddies, Table1557
Caddy, Waste Container266	Cafeteria Supplies	Aluminum Foil.....1583	Cling Wrap.....1583
Coffee Equipment.....1583-1584	Coolers.....1586	Cup Dispensers.....1583	Cups.....1583
Forks.....1583	Knives.....1583	Microwave Ovens.....1584	Napkin Dispensers.....343-344, 1583
Napkins.....343-344, 1583	Plates.....1583	Refrigerators.....1584	Spoons.....1583
Stirring Sticks.....1583	Straws.....1583	Table Caddies.....1557	Tables.....382, 1556-1557
Calibration Gas Regulator484-486	Calipers, Digital1275, 1309-1310	Cam & Groove Fittings, Pumps263	Cameras
Inspection.....1376, 1485	Thermal.....1470	Cans	Bench.....992
Drip.....670	Garbage.....169, 266-275, 349-350,383, 761, 1577	Gas.....671-672	Jerry.....671-672
Oil.....999	Oily Waste.....670-671	Plunger.....670	

INDEX

Safety.....	668-669	Office.....	1546, 1548-1549, 1553-1554	Cleaners		Liquid Repellent.....	638, 1045
Step.....	269-270, 761	Stacking.....	1555	Battery.....	1015	Rubber.....	1012, 1015, 1045
Cantilever Racks	52	Task.....	1546, 1551	Degreasers.....	312-315, 319, 1002-1007, 1015, 1036, 1144	Coating Thickness Gauges	1478
Cap Seal Crimpers	250-251	Chalk Lines	1279	Electrical.....	319, 686, 1005-1007, 1015, 1037	Coatings	
Cap Seals, Drum	251	Changing Tables	348	File.....	1037	Anti-Slip.....	873, 1019
Cape Chisels	1368	Channelizers, Traffic Control	864	Hand.....	315, 324-329, 331-332	Anti-Spatter.....	1143, 1145, 1147
Caps		Chaps, Welding	1132	Heavy-Duty.....	1037	Belt Dressing.....	1012
Bump.....	415, 417	Chargers		Industrial.....	310-320, 349, 759-760, 889, 1003-1005, 1014-1015, 1020, 1037, 1043, 1144-1146	Floor.....	311, 362, 873, 1019, 1021
Insulator.....	1098	Batteries.....	1167, 1507, 1515	Laundry Detergents.....	317	Galvanizing Compounds.....	1014, 1144, 1146-1147
Welding.....	1125, 1133	Cordless Drill.....	1167	Welding Tip.....	1073	Marking Wands.....	1038-1040
Caps & Plugs, Pipe Thread	1240-1242	Flashlight.....	1515			Paint.....	1040
Carabiners	516, 520	Checklist Kit, Forklift	187			Rust Converters.....	1014, 1146, 1148
Carbon Monoxide Meters	487	Chemical Hazard Signs	804, 808			Rust Preventers.....	1014, 1146
Carburetor Cleaner	1015	Chemical Resistant Boots	631			Striping Machines.....	1039-1040
Cargo Bars	212, 1457	Chemical Resistant Clothing		Cleaning Equipment		Wood Fillers.....	1022
Cargo Nets	1455	Aprons.....	530-531, 533	Broom & Mop Racks.....	286	Coats	
Carpenter Axes	368	Coveralls.....	537-539	Brooms.....	287-290, 301	Arc Flash.....	556
Carpenter Squares	1280	Chemical Resistant Gloves	583-592	Brushes.....	26, 291-292, 300-301, 349, 946, 1383, 1386	Flame Resistant.....	556
Carpenters' Glue	1029	Chest Protectors, Welding	1125	Buckets.....	305-307	Heat Resistant.....	551
Carpet Cleaners	317	Chest Waders	633	Buckets / Wringers.....	306-307	Winter.....	552
Carriage Bolts	85, 89	Chests, Tool Storage	1309-1310, 1394-1399, 1402-1403	Carts.....	275, 309	Coffee Equipment	1583-1584
Carton Rack	1434	Chippers, Air	1088, 1207, 1213	Dusters.....	294, 302, 320	Coil Cleaner	1309-1312, 1367-1368, 1370
Carton Staplers	1446-1447	Chipping Hammers, Welding	1087-1088	Dustpans.....	290, 296, 687	Cold Chisels	731-732, 734, 750
Cartridge Rolls	929	Chisel Holders	1367	Mops.....	292-295, 304-306	Cold Compresses	1091
Cartridges, Respirator	456, 460-464, 466, 470, 472-473, 475, 477, 480	Chisels		Pads.....	292, 294, 302, 320, 362	Cold Wire Feed Torches	1091
		Cape.....	1368	Pressure Washers.....	374-375	Cold Wire Feeders, TIG Torch	1091
		Cold.....	1309-1310, 1312, 1367-1368, 1370	Scrubbers.....	292, 302, 320	Collapsible Containers	44-45
		Hand.....	1194, 1381	Squeegees.....	296-299, 301, 687	Collet Bodies, TIG Torch	1107-1109
		Scaling.....	1088, 1194	Sweepers.....	286, 358	Collets, TIG Torch	1105-1109
		Woodworking.....	1367	Trigger Sprayers.....	302, 320	Column Protectors	86
Carts		Chucks		Vacuum Cleaners.....	352-361, 688, 1225	Combination Saw Blades	1203
Audio-Visual.....	1560-1561	Rail.....	210	Water Brooms.....	377	Combination Slip-Joint Pliers	1377
Bin.....	7-8	Wheel.....	210-211	Window Washers.....	299	Combination Wrenches	1331-1333
Cabinet.....	660, 662	Chop Saws	914, 1174	Wringers.....	294, 307	Sets.....	1309-1310, 1312, 1332, 1334, 1337
Computer.....	1561	Chucking Reamers		Cleaning Fluids, Parts Washers	995	Combined Drills & Countersinks	961
Drum.....	701	Cobalt.....	985	Cleats	636, 872	Combo Kits	1164-1166
Drywall.....	159	HSS.....	981-985	Clevis Grab Hooks	192-193	Combustible Gas Detectors	487
Gas Cylinder.....	1078	Chucks		Cling Wrap	1583	Communication	
Hose Reel.....	1237	Air.....	1224	Clipboards	1579	Cell Phone Accessories.....	443
Janitorial.....	275, 309	Drill.....	1268-1269	Clips, Alligator	1460, 1463	Cell Phone Holders.....	443, 1387, 1390
Ladder.....	134	ER Collet.....	1269	Clocks		Horns.....	221
Laundry.....	303	Circuit Breaker Extension Cords	1538	Time.....	1575	Megaphones.....	444
Lumber.....	159-160	Circuit Breaker Lockouts	781-782	Wall.....	1575	Signal Horns.....	444
Order Picking.....	165	Circuit Testers	1461, 1539	Close Quarter Drills	1184	Two-Way Radios.....	435, 438-439, 441-442
Parts Storage.....	42	Circular Saw Blades	914, 1202-1203	Closures, Drum	234, 251	Compound Leverage Wrenches	1372
Security.....	77	Circular Saws		Clothes Hooks	350	Compounds	
Shelf.....	73, 76-77, 161-165, 167-168, 170	Framing.....	872	Clothing		Buffing.....	937
Shop.....	7-8, 42, 73, 76-77, 161-170	Heavy-Duty.....	1162, 1177	Arc Flash.....	554-557	Retaining.....	1027
Stock Picking.....	165	Circular Split Dies	978, 980	Chemical Resistant.....	530-531, 533, 537-539	Sweeping.....	290
Tool.....	123-125, 1395, 1397, 1400	Citrus Base Cleaners	319, 1003, 1005, 1036	Cooling.....	645-647	Tapping.....	1149
Trades.....	169	Clamp Meters		Flame Resistant.....	538, 541-542, 548, 554-557	Compresses	729-732, 734-735, 743, 746, 750
Utility.....	76, 166, 168-170	AC / DC.....	1466	Flame Retardant.....	542, 548	Compressors	
Welding.....	1078	Current Clamps.....	1461, 1466, 1468, 1540	General Protection.....	527, 529, 531-539, 689-693, 697	Air.....	1262-1265
Wire Spool.....	167	True RMS.....	1460, 1466	Hangers.....	1581	Electric.....	1262-1264
Cases		Clamps		Heat Resistant.....	551	Gas.....	1263-1265
Blade Disposal.....	1438	Angle.....	1285	High Visibility.....	543, 545-549, 551	Computer Cabinets	1559-1560
Equipment.....	1461, 1464-1465, 1471	Bar.....	1284-1287	Limited Use.....	527, 529-539, 689-693, 697	Computer Carts	1561
Eyewear.....	407	Beam.....	199, 519	Rainwear.....	540-543, 548, 551-552	Computer Desks	1560
Small Parts.....	36	C-Clamps.....	1288-1289	Suspenders.....	1389	Computer Supplies	
Casters	137, 152-154, 162-165, 171, 176-177, 227-231, 245-246, 1119, 1433, 1550	Drum Lifting.....	240, 243	Grounding Mats.....	904	Keyboard Trays.....	1558
		Ear.....	1238	Keyboard Wrist Rests.....	1558	Monitor Stands.....	1577
Caulk	1025	Edge-Gluing.....	1288	Conductivity Meters	1490	Conditioners	
Caulking Guns	1018, 1023-1024, 1035, 1045, 1161	Ground - Welding.....	1086	Air.....	1500	Skin.....	333
		Hold-Down.....	1290-1292	Conductor Tubes, MIG Gun	1096	Conductivity Meters	1490
Caution Tags	790	Hose.....	1238	Cone Bars	863	Cones	
C-Clamps	1288-1289	Latch.....	1290-1292	Crowd Control.....	296, 308	Crowd Control.....	296, 308
Ceiling Fans	1498	L-Clamps.....	1284	Pallet.....	48, 1423	Pallet.....	48, 1423
Ceiling Mounted Heaters	1504	Lifting.....	198	Safety.....	308	Safety.....	308
Cell Phone		Paper.....	1565	Traffic Control.....	862-863	Traffic Control.....	862-863
Accessories.....	443	Parallel.....	1286-1287	Confined Space Lockouts	784	Confined Space Signs	758, 804, 808
Holdings.....	443, 1387, 1390	Pipe.....	1285	Confined Space Signs	758, 804, 808	Connectors	
Cements, Pipe	1022	Quick.....	1288	Anchorage.....	516-517, 519	Anchorage.....	516-517, 519
Center Punches	1309-1310, 1312, 1368, 1370	Spring.....	1288	Cable.....	1084-1085	Cable.....	1084-1085
Centrifugal Blowers	489	Straight Line.....	1290, 1292	Swivel.....	1219, 1250	Swivel.....	1219, 1250
Ceramic Magnets	1299	Toggle.....	1290-1291	Wire.....	1543	Wire.....	1543
CFC Free Degreasers	319, 1002-1003, 1007	Claw and Ripping Hammers	1364				
Chain		Claw Hammers	1362, 1364				
Beaded.....	794	Clean Air Solvents	1002				
Crowd Control.....	794, 880	Clean Room Matting	907				
Lifting.....	193	Cleaner, Carburetor	1015				
Chain Nose Pliers	1348						
Chain Wrenches	1372						
Chains, Key	1570-1571						
Chair Caddies	1554						
Chairs							
Ergonomic.....	1547-1549, 1554						
Folding.....	382, 1554						

Conspicuity Tape.....850

Construction, Vapor Barriers.....1437

Construction Adhesives.....1029

Construction Tape.....1437

Contact Cement.....1029

Contact Cleaners.....1005-1007

Contact Tips, MIG Gun.....1094-1098

Container FDA Liners.....280

Containers

- Bottles.....28
- Collapsible.....44-45
- Distribution.....18-20, 22-24, 1564
- ESD.....25
- Food Handling.....175
- Jars.....28
- Mobile Bins.....6
- Nesting Bins.....18-19, 26
- Poly.....27, 234, 671
- Recycling.....276-279, 1577
- Revolving Bins.....29
- Salt & Sand.....363, 689
- Shelf Bins.....13-15, 25
- Small Parts Bins.....11, 25, 31, 39
- Spill Control.....709-710
- Stacking Bins.....4-6, 13-14, 16-17, 21, 26, 40-41
- Steel Bins.....40-41, 44-45
- Tanks.....27
- Transfer Boxes.....19

Control Valves.....1000

Convertible Pliers.....1353

Convex Mirrors.....882

Conveyors.....224-225

Cooking Thermometers.....1471, 1473

Coolant Tanks.....1150

Coolers

- Containers.....1586
- Water.....650

Cooling Clothing

- Hard Hat Liners.....646
- Hats.....645
- Headbands.....645, 647
- Neck Shades.....647
- Towels.....645-646
- Vests.....646-647
- Wraps.....645, 647

Copper Hammers.....1365

Cord Reels

- Extension Cords.....1531-1532, 1537
- Fluorescent.....1532
- Incandescent.....1531-1532
- Quad Box.....1531
- Single Outlet.....1531-1532
- Triple Outlet.....1532
- Work Lights.....1531

Cord Retainers, Eyewear.....408

Cord Sets, GFCL.....1539

Cordless Power Tool Batteries.....1156-1164, 1167

Cordless Screwdrivers.....1161, 1187

Cords

- Bungee.....1455, 1457
- Extension.....1535-1538, 1541

Core Bits.....1194

Coring Motors.....1189

Corkboards.....1569

Corn Brooms.....289-290

Corner Protectors.....48, 86-87, 216, 1421, 1423

Corrugated Boxes.....1431

Corrugated Pads.....1431

Corrugated Paper.....1430

Corvers, Pallet.....1423

Cotton Balls.....747

Cotton Tip Applicators.....729, 732, 747

Cough and Cold Relievers.....752

Counters

- Measuring.....1484
- Ratchet.....1483
- Tally.....1483

Countersinks.....962

Countersinks & Drills, Combined.....961

Counting Scales.....1491

Couplers, Quick.....1207, 1233, 1246, 1248-1250

Couplings, Pipe Thread.....1240-1241, 1243-1244

Coveralls

- Arc Flash.....554-556
- Chemical Resistant.....537-539
- Flame Resistant.....538, 554-556
- General Protection.....532-539, 689-693, 697
- Limited Use.....537-539
- Work.....550, 554

Covers

- Boot.....289, 527, 534, 632, 889
- Drum.....236, 670, 699
- Fire Extinguisher.....653
- Pail.....236
- Shoe.....289, 527, 889
- Toilet Seat.....348
- Waste Containers.....266, 268, 271-272, 276-277

CPR

- Kits.....763
- Masks.....729-730, 762-763
- Shields.....729-735, 762

Crack Check.....1012, 1020, 1144, 1148

Crane Scales.....203, 1496

Cranes

- Floor.....200, 202
- Gantry.....200
- Jib.....201
- Shop.....202, 208
- Truck Mounted.....202

Crayons

- Lumber.....1142, 1444
- Temperature.....1142, 1445

Cream Dispensers.....331

Creams

- Burn Care.....749
- Hand.....331, 333
- Skin.....333

Crimped Filament Wheels.....912-913

Crimpers

- Cap Seal.....250-251
- HVAC.....1359

Crimping Die Pliers.....1349, 1377

Cross Check Tamper Proof Indicator.....1342

Cross-Arm Strap Anchors.....519, 560

Crosses, Pipe Thread.....1244

Crossover Ladders.....140

Cross-Point Bits.....1345

Cross-Point Screwdrivers.....1309-1312, 1338-1341, 1378, 1383, 1386

Crowbars

- Non-Sparking.....1380
- Pitch Point.....368

Crowd Control

- Base.....874
- Chain.....794, 880
- Cones.....296, 308
- Rope & Posts.....821, 874-880
- Wall mounted.....875, 877

Crutches, First Aid.....758

CSA Standard Signs.....814-817

Cultivators.....368

Cup Brushes.....945

Cup Dispensers.....1583

Cup Magnets.....1299

Cupmounts.....1272

Cups

- Cafeteria.....1583
- Measuring.....317, 994
- Vacuum.....196-197

Curtain, Privacy Shower.....727

Curtains, Strip.....91-93

Curved Blade Knives.....1382, 1386

Curved Claw Hammers.....1309-1312, 1364, 1380

Cut & Polish Wheels.....938

Cut Resistant Gloves.....575-581, 613

Cut-Off Blades.....1203

Cut-Off Tools, Air.....1204

Cut-Off Wheels.....912-916

Cutters

- Annular.....972, 1193
- Bolt.....1360-1361
- Cable.....1085, 1349, 1351-1352, 1361, 1377
- Insulated.....1377
- Iron Shear.....1361
- Paper.....1427, 1432-1433
- Rebar.....1361
- Rotary.....1163
- Tubing.....1374

Cutting Attachments, Welding.....1065

Cutting Fluids

- for all Metals.....1148-1149
- for Aluminum.....1148
- for Steel.....1148

Cutting Tips.....1065, 1070-1072

Cutting Tools

- Adjustable Reamers.....985
- Annular Cutters.....972, 1193
- Auger Bits.....1199
- Burs.....990-991, 1215
- Chucking Reamers.....981-985
- Circular Saw Blades.....914, 1202-1203
- Circular Split Dies.....978, 980
- Combination Saw Blades.....1203
- Combined Drills & Countersinks.....961
- Core Bits.....1194
- Countersinks.....962
- Cut-Off Blades.....1203
- Die Stocks.....977
- Drill Bits.....948-955, 963-972, 1193, 1196, 1198-1199
- End Mills.....986-989
- Forstner Bits.....1199-1200
- Hand Reamers.....981
- Hand Taps.....956-960, 974-975, 977, 988
- Hexagonal Dies.....978-979
- Hole Saws.....1193, 1197-1198
- Machine Taps.....976
- Mitre Saw Blades.....1203
- Pipe Taps.....960, 973
- Points.....1194
- Prentice Drill Bits.....969-970
- Reciprocating Saw Blades.....1201
- Rotary Hammer Bits.....1195-1196
- Screw Extractors.....960, 989
- Tap & Drill Sets.....973
- Taper Pin Reamers.....982
- Tool Holders.....986, 1269

Cutting Torches.....1065

-D-

D Handle Drills.....1183-1184

Danger Tags.....790

Davits.....490-491

D-Bolt Anchors.....516, 519

Dead Blow Hammers.....1309-1312, 1362-1363

Deburring Hand Tools.....1308

Deburring Wheels.....936, 938, 1271

Decking Beams.....212, 1457

Degreasers

- CFC Free.....319, 1002-1003, 1007
- Engine.....1015
- Flash Free.....1007
- Food Grade.....1003-1004, 1007
- Heavy-Duty.....312-315, 319, 1002-1005, 1036
- Multi-Purpose.....312, 319, 1002-1004
- Non-Chlorinated.....1144
- Solvent Free.....313, 1002-1003

Deheaders, Drum.....250

De-Icer.....1015

Delineators, Traffic Control.....863-864

Demolition Hammers.....1187

Depressors, Tongue.....734, 747

Desiccant Systems.....1251, 1257

Desiccants.....1429

Desk Lamps.....1524, 1582

Desk Organizers.....1577

Desks

- Computer.....1560
- Office.....1567
- Shop.....102, 126

Detergents, Laundry.....317

Dettol™.....748

Developers

- Non-Aqueous.....1144
- Non-Chlorinated.....1020, 1144

Diagonal Cutters.....1309-1312, 1348, 1350, 1353, 1377, 1383

Dial Scales.....1494

Diaphragm Pumps.....258

Die Grinders

- Air.....1204, 1212, 1215, 1220, 1223
- Electric.....1172

Dielectric Greases.....1018

Dielectric Hasp Lockouts.....780

Dies

- Circular Split.....978, 980
- Die Stocks.....977
- Hexagonal.....978-979

Diesel Conditioner.....1015

Diffusers, MIG Gun.....1095-1098

Digital Thermometers.....1472-1473

Dilution Dispenser.....313

Dip Tanks.....992

Dipping Baskets.....992

Direction Signs.....811

Directory Boards.....1569

Disc Holder Pads.....922-925, 927, 935-936, 938

Discharge Hoses.....263

Discs

- Bristle.....921
- Flap.....918-919
- Grip-On.....926
- Resin Fibre.....922-923, 925
- Roloc™ / Power-Lock.....924-925, 935
- Stick-On.....926-927
- Surface Conditioning.....934-936, 938

Dish Detergents.....316

Disinfectants.....313-314, 318, 759-760

Dispenser Bottles.....672

Dispenser Dilution.....313

Dispensers

- Aisle Marking Tape.....868
- Box Sealing Tape.....1411, 1429
- Cream.....331
- Cup.....1583
- Dust Mask.....453
- Ear Plug.....427, 431
- Filament Tape.....1411-1413
- Gloves.....600
- Gummed Tape.....1411, 1413
- Hand Sanitizer.....323-324
- Hand Soap.....315, 324-326, 330-333
- Napkin.....343-344, 1583
- Paper Towel.....340-343, 1583
- Reel.....167
- Sanitary Napkin.....348
- Scotch™ Tape.....1580
- Strapping.....1420, 1422
- Stretch Wrap.....1424-1426
- Toilet Paper.....345-347
- Toilet Seat Cover.....348
- Two-Way Tape.....1416
- Wipes.....334, 336, 338-340

Display Hangers, Merchandise.....1435

Displays, Literature.....1568

Disposable Dust Masks.....447, 453

Disposable Face Mask.....447

Disposable Gloves.....594-600, 656, 729-735, 762

Disposable Respirators.....447-453

Distribution Containers.....18-20, 22-24, 1564

Dock Equipment

- Bumpers.....213
- Cable & Hose Protectors.....217
- Dock Risers.....215
- Dockboards.....215
- Dockplates.....215
- Fenders.....212

INDEX

Levelers.....	214	Hammer Drill / Driver.....	1157-1159	Dust Masks, Disposable	447, 453	Slot Drills.....	986-987
Lights.....	218-220	Hand Powered.....	1182-1183, 1186	Dust Mop Frames	293-295, 302	Square End.....	988-989
Pallet Pullers.....	186	Drills & Countersinks, Combined	961	Dust Mops	293, 295	Supermills.....	987
Rail Chocks.....	210	D-Ring Harnesses	495	Dusters		Weldon Shank.....	986-987
Twin Ramps.....	214	Drinks, Rehydration	648-649	Aerosol.....	319, 1006-1007	End Wrenches	1373
Walkramps.....	214	Drip Cans	670	Janitorial.....	294, 302, 320	Engine Degreasers	1015
Wheel Chocks.....	210-211	Drip Pans	252, 680-681	Dustpans	290, 296, 687	Engine Stands	208
Dock Lights		Drive Pin Punches	1369	Dye Penetrants	1012, 1020, 1144, 1148	Engine Tilters	208
Double Strut.....	219	Drop Sheets	1054	Drops, Eye	728	Engine-Powered Pumps	264
Flexible.....	218-219	Drum Equipment				Engravers	
Halogen.....	218	Bonding & Grounding Wires.....				Air.....	1212, 1223
Incandescent.....	219	252-253, 665			Dremel.....	1192
Single Strut.....	218-219	Cabinets.....	663, 665	Ear Clamps	1238	Entrance Matting	
Stop & Go.....	220	Cap Seals.....	251	Ear Muffs		Carpet.....	886-887
Docking Stations	482-483, 485-486	Carts.....	701	Cap Mounted.....	433-439	Eco.....	886
Document Laminators	1574	Closures.....	234, 251	Headband.....	433-438, 549	Needle Rib.....	885
Dollies		Covers.....	236, 670, 699	Hygiene Kits.....	435	Pile.....	885-888
Aluminum.....	177	Deheaders.....	250	Neckband.....	434, 436-437	Polypropylene.....	885
Cabinet.....	97, 103	Dollies.....	244, 266, 701-702	Ear Plugs		Rubber.....	886-888, 901, 909
Drum.....	244, 266, 701-702	Faucets.....	251-252	Corded.....	423-426, 428-429	Vinyl.....	901
Gas Cylinder.....	1078	Funnels.....	241, 251, 699	Dispensers.....	427, 431	Wiper.....	874, 885-887
Knee.....	209	Gauges.....	251	Disposable.....	423-427	Envelopes, Packing List	1449
Mechanic's.....	209	Heaters.....	237	Reusable.....	426, 428-429	Environmental Cleaners	317-318
Pail.....	244	Lids.....	423-429	Uncorded.....	423-429	Epoxies	
Polyethylene.....	177	Lifters.....	238-243, 701	Ear Protection Signs	806, 809	for Metal.....	1020-1021
Pry.....	177	Liners.....	235	Earloop Face Mask	447	General Purpose.....	1023, 1033-1034
Stacking.....	20	Mixers.....	249	Edge Protectors	48, 86-87, 216, 1421, 1423	Mixer Cups.....	1021
Steel Deck.....	97, 103	Pail Heaters.....	237	Edge-Gluing Clamps	1288	Putty.....	1020-1021, 1023
Waste Container.....	266, 271, 276-277	Pail Inserts.....	235	Ejectors, Smoke	1501	Syringe.....	1021
Wheel.....	177, 208	Pail Tipplers.....	245	Elastic Bandages	731, 740, 746	Two Part.....	1033
Wood.....	176	Pail Tumblers.....	248	Elbow Protectors	643	Epoxy Applicators	1021, 1035
Dome Mirrors	881, 883	Pails.....	27, 695-696	Elbows, Pipe Thread	1240-1244	Epoxy Coating	1042-1043
Doors, Curtain	91-93	Pallet Servers.....	239	Electrical Cleaners		Epoxy Paint	1042-1043
Double Faced Hammers	1366	Pumps.....	254-258	Anti-Static.....	1007	Equalizers, Battery	1037
Double Sided Tape	1416	Racks.....	245, 703	Contact.....	1005-1007	Equipment Cases	1461, 1464-1465, 1471
Double Stepladders	129-131	Rockers.....	245	Dusters.....	319, 1006-1007	Equipment Stands	170
Drain Augers	1375	Rotators.....	239, 248	Electrical Gloves	558-559	ER Collet Chucks	1269
Drain Cleaners	316	Spill Pallets.....	704-708, 710, 713-714	Electrical Hazard Signs	804-805, 808	Ergonomic Products	
Drain Protectors	682	Spotters.....	247	Electrical Plug Lockouts	781-782	Back Supports.....	641-642
Drain Seals	681-683, 689-693	Stackers.....	242	Electrical Supplies		Elbow Protectors.....	643
Drain Spades	366	Strainers.....	235	Alligator Clips.....	1460, 1463	Forearm Protectors.....	643
Drains, Air	1257	Tilters.....	239-240, 254	Batteries.....	1507	Gloves.....	601-603, 605
Drawers, Cabinet	37	Trays.....	681, 703, 711, 713	Battery Chargers.....	1167, 1507, 1515	Knee Pads.....	639-640, 1133
Dremel Tools	1192	Trucks.....	246-247	Booster Cables.....	1542	Kneeling Pads.....	639
Drench Hoses	726	Upenders.....	250	Cable Protectors.....	218, 1540	Seating.....	1547-1549, 1554
Dressings		Valves.....	252	Connectors.....	1219, 1250, 1543	Tennis Elbow Braces.....	643
Burn Care.....	732, 753	Vents.....	251	Cord Reels.....	1531-1532, 1537	Wrist Supports.....	643-644, 746
Eye.....	728, 734	Drum Fans	1497, 1502	Extension Cords.....	1535-1538, 1541	Escape Ladders	656
Drift Punches	1309-1310, 1369-1370	Drum Tools		GFCI Products.....	1539-1542	ESD Products, Bins	25
Drill Bits		Cap Seal Crimpers.....	250-251	Outlet Boxes.....	1539	Exhaust Fans	1501
Aircraft Extension.....	968, 972	Pail Openers.....	250	Plugs.....	1084	Exit Lights	1521
Hex Shank.....	1198	Wrenches.....	250	Power Bars.....	1541	Exit Signs	807, 810-811, 1521
Jobber.....	948-953, 963-967	Drums		Receptacles.....	1084	Expandable Gates	309
Masonry.....	1196	Fibre.....	234	Tape.....	1417, 1544	Extension Cords	
Silver & Deming.....	954	Polyethylene.....	234, 691-695	Circuit Breaker.....	1538	Circuit Breaker.....	1538
Spiral Flute.....	972	Steel.....	234, 236	Double Outlet.....	1541	Double Outlet.....	1541
Spline-Shank.....	1196	Dry Lubricants		Single Outlet.....	1535-1538, 1541	Single Outlet.....	1535-1538, 1541
Straight Shank.....	971	Graphite.....	1008	Timers.....	378	Triple Outlet.....	1535-1537
Stub.....	953-954	Silicone.....	1010	Wire Strippers.....	1351	Extension Ladders	132-133, 135
Taper Length.....	969	Synthetic.....	1009, 1012	Electrical Switch Lockouts	781	Extension Poles	287-288, 292-294, 297-299, 302, 1048
Taper Shank.....	955, 971	Dryers		Electrode / Rod Containers	1089, 1134	Extensions, Forklift	187, 242
Through-Hole.....	1199	Air.....	1251, 1257	Electrode Holders	1084	Extinguisher Cabinets	653
Two-Piece.....	1193	Hand.....	351	Electrode Ovens	1089	Extinguishers, Fire	651-652
Drill Press Vises	1295-1296	Drywall Carts	159	Electrodes		Extractors	
Drill Presses		Drywall Tools		Gouging.....	1087	Fume.....	1058-1060
Bench.....	1266-1267	Hand Sanders.....	1053	Stick.....	1136-1137, 1139	Screw.....	960, 989
Electromagnetic.....	1188-1189	Hawks.....	1053	Tungsten.....	1114	Extraction Devices	754-755
Floor.....	1266-1267	Knives.....	1052-1053, 1382, 1386	Electromagnetic Drill Presses	1188-1189	Eye Baths	728, 734
Drilling Machines		Putty Knives.....	1052, 1382, 1386	Emergency Blankets	756	Eye Bolts	194
Drill Presses.....	1188-1189, 1266-1267	Razor Blades.....	1052	Emergency Escape Respirators	459	Eye Dressings	728, 734
Gearhead.....	1267	Sanding Blocks.....	1053	Emergency Lights	1521-1522	Eye Drops	728
Drills		Saws.....	1053	Emergency Showers	718-719	Eye Patches	728, 730, 735
Air.....	1205, 1209, 1221-1223	Scrapers.....	1052, 1382	Enclosures		Eye Protection Signs	806, 809
Angle.....	1184	Spatulas.....	1382	Fences.....	866	Eyewash, Water Heater	721
Chucks.....	1268-1269	Trowels.....	1053	Steel Mesh.....	90	Eye Wash Stations	
Close Quarter.....	1184	T-Squares.....	1280	End Brushes	940, 942, 944	Bottled.....	724-725
D Handle / Spade Handle.....	1183-1184	Duct Tape	1415	End Cutters	1349	Faucet Mounted.....	720
Drill / Drivers.....	1182	Dump Trucks	172-173	End Mills		Matting.....	727, 893
Drill / Drivers - Cordless.....		Durometers	1479	Ball End.....	988-989	Pedestal Mounted.....	717
.....	1156-1158, 1161, 1164	Dust Collectors, Sandblasting	1056	Carbide.....	988-989	Self Contained.....	722-723, 725
Hammer.....	1158-1159, 1184-1187	Dust Mask Dispensers	453	HS-Co.....	986-987	Sink Mounted.....	720



Solutions..... 722-725, 728, 734
 Supplemental..... 724-725
 Wall Mounted..... 716, 720
 Water Preservatives..... 722-723, 725

Eyewear
 Cases..... 407
 Cord Retainers..... 408
 Reading Glasses..... 399
 Safety Glasses..... 386-403, 407, 1310-1311
 Safety Goggles..... 404-406, 412, 689-697, 1120
 Welding Goggles..... 1120

-F-

Fabric Bandages..... 734, 740-742, 745
Fabric Shears..... 1357
Face Mask..... 447
Faceshields..... 410-413, 557
Facial Tissue..... 344

Fall Protection
 Anchorage Connectors... 516-517, 519, 560
 Carabiners..... 516, 520
 Davits..... 490-491
 Fall Protection Kits..... 505-507
 Harness..... 496, 500
 Harnesses..... 141, 494-502, 519, 560
 Kits..... 505-507
 Lanyards..... 141, 492, 507-515, 522-524, 560
 Life Lines..... 492, 512-515, 517-518, 520
 Rescue Hoist..... 492
 Rescue Systems..... 490-492, 496, 518
 Rope Grabs..... 517-518, 520
 Signs..... 806
 Winches..... 492

Fall Protection Kits..... 505-507
Fall Protection Lanyards, Hard Hat..... 420, 522, 524

Fan Forced Heaters..... 1503, 1505
Fan Guards..... 489

Fans
 Ceiling..... 1498
 Drum..... 1497, 1502
 Exhaust..... 1501
 Floor..... 1499
 Fume Extractor..... 1058
 Guards..... 489
 Office..... 1499
 Pedestal..... 1497-1499
 Wall Mounted..... 1497-1499

Fasteners
 Carriage Bolts..... 85, 89
 Eye Bolts..... 194
 Hex Nuts..... 85, 89
 Hook & Loop..... 1577
 Nails..... 1446
 Staples..... 1447
 Thread Repair..... 1307

Faucets
 Bathroom..... 350
 Drum..... 251-252

Fault Detectors, Welding..... 1012, 1020, 1144, 1148

FDA Liners..... 280

Feeders, Cold Wire..... 1091

Feeler Gauge Stock..... 1274

Fences
 Barrier..... 866
 Safety..... 865
 Snow..... 865

Fenders, Dock..... 212

Filament Tape..... 1412
Filament Tape Dispensers..... 1411-1413

File Cleaners..... 1307

File Folders..... 1564, 1579

File Handles..... 1307

Files
 Chain Saw Sharpening..... 1302
 Flat..... 1302-1305
 Half Round..... 1303
 Lathe..... 1303

Mill..... 1304
 Round..... 1302, 1304
 Sets..... 1306-1307
 Square..... 1304
 Thread Repair..... 1307
 Triangular..... 1304-1305
 Warding..... 1305

Filing Boxes..... 1564

Filing Cabinets
 Lateral..... 1562-1563, 1565
 Oversized Files..... 1566
 Vertical..... 1562-1563, 1565

Filing Trays..... 1577

Filler Metals..... 1136-1138, 1140

Fillet Gauges..... 1073

Filter Plate Lenses..... 1122, 1128

Filter Plates..... 1126, 1128

Filter/Regulator/Coalescing Filters..... 1257-1258, 1260

Filter/Regulator/Lubricators..... 1255, 1258-1259

Filter/Regulators..... 1255-1256, 1259

Filters
 ADF..... 1121, 1124-1126
 Air..... 359, 1058, 1251, 1255-1260, 1500, 1506
 Mechanical..... 1059
 Respirator..... 452, 456-461, 464, 475, 480
 Water..... 1585-1586

Finger Splints..... 754

Fingercots..... 600

Finishing Wheels..... 938

Fire Protection
 Blankets..... 656, 753
 Extinguisher Cabinets..... 653
 Extinguisher Covers..... 653
 Extinguishers..... 651-652
 Fire Alarm Protectors..... 654-655
 Signs..... 653, 807, 810, 812, 817, 822
 Smoke Alarm Testers..... 656
 Smoke Alarms..... 655

First Aid
 Airway Kits..... 763
 Ammonia Inhalants..... 734, 763
 Antiseptics..... 729-735, 745, 748-749, 759
 Bandages..... 729-735, 740-743, 745-747
 Blankets..... 729, 732, 756-757
 Burn Care..... 732, 749, 753
 Cabinets..... 739
 Coagulants..... 742, 761
 Compresses..... 731-732, 734, 750
 Cotton Products..... 729, 732, 747
 CPR Devices..... 729-735, 762-763
 Crutches..... 758
 Drench Hoses..... 726
 Dressings..... 728, 734
 Emergency Showers..... 718-719
 Extrication Devices..... 754-755
 Eye Care..... 728, 730, 734-735
 Eyewash Stations..... 716-717, 720-725, 728, 734
 Furnishings..... 757-758
 Instrument Tray..... 751
 Instruments..... 729-735, 747, 751, 756
 Kits..... 729-739, 745
 Leg Splints..... 754
 Lip Balm..... 335, 384, 750
 Literature..... 729-735
 Ointments..... 729-732, 745, 748-749
 Oxygen Mask..... 763
 Sharps Collectors..... 757, 760
 Signs..... 727, 805, 809, 812
 Stethoscopes..... 756
 Stretchers..... 754-755
 Tape..... 729, 744
 Thermometers..... 756
 Wheel Chair..... 758

First Aid Instruments, Sanitizing Solution..... 751

First Aid Room Furnishings..... 757-758

Fit Test Kits, Respirators..... 465

Fitters' Gloves..... 608-613, 618, 1310-1311

Fittings
 Air Hose..... 1234, 1239, 1247, 1250
 Cam & Groove..... 263
 Lubrication..... 999-1001
 Push to Connect..... 1239

Fixtures, Light..... 1520

Flagging Tape..... 869

Flags
 Marking..... 871
 Snow..... 871
 Traffic Control..... 858

Flagstaffs..... 856

Flame Resistant Clothing
 Coats..... 556
 Coveralls..... 538, 554-556
 Hoods..... 556-557
 Jackets..... 555
 Overalls..... 555-556
 Pants..... 554
 Rainwear..... 541-542, 548
 Shirts..... 554

Flame Retardant Clothing, Jackets..... 542, 548

Flange Sealants..... 1026

Flap Brushes..... 937

Flap Discs..... 918-919

Flap Wheels..... 919-920, 937

Flare Nut Wrenches..... 1335-1336

Flares, Traffic Control..... 859

Flaring Tools..... 1374

Flash Free Degreasers..... 1007

Flashback Arrestors..... 1074

Flashing Lights..... 222-223, 863, 866

Flashlights
 12 V..... 1162, 1513
 18 V..... 1162
 AA Cell..... 1511-1519
 AAA Cell..... 1509-1510, 1512, 1514, 1517
 Belt Holsters..... 1509-1511
 C Cell..... 1512-1513, 1516
 Coin..... 1514
 CR123 Cell..... 1511
 D Cell..... 1509-1510, 1517
 Hazardous Locations..... 1513
 Mini..... 1509, 1514, 1517, 1519
 N..... 1513
 Pocket..... 1512, 1515
 Rechargeable..... 1162, 1511, 1513, 1515-1516, 1518-1519
 Tactical..... 1512
 Waterproof..... 1513, 1517-1518

Flat Files..... 1302-1305

Flat Fold Respirator..... 447

Flat Mirrors..... 882

Flat Tip Screwdrivers..... 1309-1312, 1338-1341, 1378, 1383, 1386

Flat Top Dispensers..... 326, 330, 332-333

Flex Head Wrenches..... 1334-1335

Flex Torches..... 1103-1104

Flexible Netting..... 1430

Flint Lighters..... 1073

Flints..... 1073

Flip Charts, TDG..... 854

Flip-Top Mitts..... 604

Floodlights..... 1162, 1520, 1526-1528, 1530

Floor Cleaners..... 310-311, 317

Floor Coating..... 1019, 1044-1045

Floor Coatings..... 311, 362, 873, 1019, 1021

Floor Cranes..... 200, 202

Floor Fans..... 1499

Floor Finishes..... 311, 362

Floor Lamps..... 1527

Floor Lock Brakes..... 231

Floor Paint..... 1019, 1044-1045

Floor Repair..... 1018-1019, 1021, 1045

Floor Scales..... 1496

Floor Scrapers..... 292, 298

Floor Sealers..... 311, 362, 1019

Floor Signs..... 308, 813
 Safety..... 296, 308

Floor Stripper..... 311, 362

Flooring Knives..... 1441

Flowmeters, Welding..... 1068

Fluorescent Lamps / Light Bulbs..... 1524-1526, 1529-1530, 1582

Flux..... 1141, 1145

Foam, Packaging..... 1427

Foam Sealants..... 1023

Folders, File..... 1564, 1579

Folding Chairs..... 382, 1554

Folding Gates..... 82-83, 309, 867

Folding Stretchers..... 754

Folding Tables..... 121, 382, 1557

Food Grade Cleaners, Non-Flammable..... 1004

Food Grade Degreasers..... 1003-1004, 1007

Food Grade Lubricants..... 1008, 1010-1011, 1018

Food Handling Containers..... 175

Food Thermometer..... 1471, 1473

Foot, Splints..... 731, 734, 754

Foot Guards
 Aluminum..... 637
 Plastic..... 637
 Steel..... 637

Foot Warmers..... 636

Footrests..... 1549

Footwear
 Boot Trays..... 889
 Brushes..... 291, 889
 Chemical Resistant Boots..... 631
 Covers..... 289, 527, 534, 632, 889
 Foot Guards..... 637
 Foot Warmers..... 636
 Insoles..... 638
 Knee Boots..... 631-632
 Overboots..... 633
 Overshoes..... 633-634
 Toe Guards..... 637
 Waders..... 633
 Winter Boots..... 635-636
 Work Boots..... 632-633

Footwear Odour Neutralizers..... 750

Force Gauges..... 1484

Forceps..... 751

Forearm Protectors..... 643

Forklift Attachments
 Drum Lifters..... 238-239, 241-242
 Extensions..... 187, 242
 Maintenance Platforms..... 141

Forklift Bump Guard..... 186

Forklift Checklist Kit..... 187

Forklift PPE Battery Kit..... 186

Forks
 Cafeteria..... 1583
 Spading..... 367

Forstner Bits..... 1199-1200

Fountain Brushes..... 799

Fountain Rollers..... 799

Fountains, Water..... 1585-1586

Frames
 Crowd Control..... 880
 Dust Mop..... 293-295, 302

Framing Saws..... 872

Freeze Spray..... 1006

Friction Bolt Anchors..... 516

Full Face Respirators..... 455, 458-459, 462-463, 469

Fume Extractor Fans..... 1058

Fume Extractors..... 1058-1060

Fume Filters, Welding..... 1058-1059

Funnels
 Clean..... 994
 Drum..... 241, 251, 699
 Pail..... 699
 Polyethylene..... 317, 994
 Spill Control..... 699
 Steel..... 993

Furniture Pads..... 1454

Furniture Polish..... 319

Fuse Blocks, TIG Torch..... 1110

-G-

Galvanizing Compounds..... 1014, 1144, 1146-1147

Gantry Cranes.....200

Garage Jacks.....206

Garbage Bag Stands.....383

Garbage Bags.....278-282, 348-349, 383, 761

Garbage Cans.....169, 266-275, 349-350, 383, 761, 1577

Garden Hose Hangers.....378

Garden Hoses.....378

Garden Spades.....366

Gas Cans.....671-672

Gas Cylinder

- Brackets.....1079
- Cabinets.....1077
- Dollies.....1078
- Lockouts.....106
- Racks.....1079
- Stands.....1079
- Trucks.....1078
- Wrenches.....1073

Gas Detectors

- Air Quality.....487, 1474
- Calibration Gas.....484-486
- Carbon Monoxide.....487
- Combustible Gas.....487
- Multi-Gas.....482-486
- Sensor.....484-486
- Single-Gas.....482, 485

Gas Hoses, Welding.....1075, 1110

Gas Torches.....1064

Gasflux[®].....1145

Gasket Remover.....1015

Gaskets.....1025-1026

Gate Valve Lockouts.....784

Gate Valves.....252

Gates

- Expandable.....309
- Folding.....82-83, 309, 867
- Security.....82-84, 216, 866, 878

Gauge Protectors, Welding.....1067

Gauges

- Coating Thickness.....1478
- Drum.....251
- Force.....1484
- Pocket.....1275
- Pressure.....1068, 1224, 1232, 1489
- Thickness.....1478-1479
- Weld Fillet.....1073

Gauze Bandages.....729-735, 743

Gaylord Liners.....4, 280

Gear Wrenches, Sets.....1333-1334, 1337

Gearhead Machines, Drilling.....1267

Gels, Burn Care.....753

General Protection Clothing

- Aprons.....529, 534
- Coveralls.....532-539, 689-693, 697
- Hoods.....527, 534
- Lab Coats.....531-534, 536, 539
- Pants.....534
- Shirts.....534

GFCI

- Cord Sets.....1539
- Outlet Adaptors.....1540
- Outlet Boxes.....1539
- Plugs.....1540
- Power Strips.....1540-1542
- UPS Systems.....1542

GHS

- Information Centres.....848
- Information Charts.....847
- Safety Labels.....844-845
- Wallet Card.....844

Glass Cleaners.....315, 1004

Glasses

- Cases.....407
- Cord Retainers.....408
- Reading.....399
- Safety.....386-403, 407, 1310-1311

Gloves

- Aluminized.....624
- Anti-Vibration.....606-607
- Canvas Cotton.....612, 628
- Chemical Resistant.....583-592
- Coated.....562-580, 591-593, 627-628
- Cotton.....612
- Cut Resistant.....575-581, 613
- Dispensers.....600
- Disposable.....594-600, 656, 729-735, 762
- Dyneema[®].....577, 579, 581
- Electrical.....558-559
- Ergonomic.....601-603, 605
- Fingercots.....600
- Fitters'.....608-613, 618, 1310-1311
- Heat Resistant.....605, 622-624
- High Voltage.....558-559
- Holders.....593, 629
- Impact.....605-607, 644
- Inspection.....625
- Jersey.....628-629
- Kevlar[®].....575-576, 578-579, 581
- Knit.....626, 629
- Latex.....598-599
- Leather.....608-613, 618-621, 1129-1131, 1310-1311
- Natural Rubber.....569, 572
- Neoprene.....590
- Neoprene / Rubber.....589-590
- Nitrile.....563-574, 580, 583-586, 594-597, 656
- Nitrile/Polyurethane.....563-569, 571-574, 580
- Parade / Waiter's.....625
- Polyethylene.....600
- Polyurethane/Nitrile.....562-563, 574-580, 593
- Polyurethane.....562-563, 574-578, 580, 593
- PVC.....571, 591-592, 627-628
- Rubber.....570, 587-589
- Rubber Latex.....570, 586-589
- Sandblasting.....591
- Stainless Steel.....581
- Vinyl.....573, 597-598
- Welding.....619-621, 1129-1131
- Winter Lined.....604-605, 609-618, 626

Glow in the Dark Tape.....811, 870, 872-873

Glow Wands.....858, 860

Glue

- Carpenters'.....1029
- Sticks.....1036, 1418
- White.....1029
- Wood.....1029

Glue Guns.....1035-1036, 1418

Goggles

- Safety.....404-406, 412, 689-697, 1120
- Welding.....1120

Gouging Electrodes.....1087

Gouging Torches.....1087

Grab Bar.....350

Graffiti Removers.....319, 1005, 1043

Grain and Coal Scoops.....366

Grease Control Valves.....1000

Grease Guns.....996-997, 1017, 1161, 1309

Grease Pencils.....1142, 1445

Grease Pumps.....999-1000

Greases

- Bearing.....1017
- Dielectric.....1018
- High Temperature.....1017
- Multi-Purpose.....1011, 1018
- Synthetic.....1018
- White Lithium.....1018

Grinders

- Angle.....916, 1163, 1168-1171
- Angle - Air.....1204, 1211, 1215, 1222
- Bench.....917, 1270
- Die.....1172
- Die - Air.....1204, 1212, 1215, 1220, 1223
- Mini Die - Air.....1215
- Pencil - Air.....1223
- Tungsten Electrode.....1113-1114

Grinding Wheels

- Bench Mounted.....917, 1271
- Depressed Center.....912, 915-916
- Type 27.....912, 915-916
- Zirconium.....913-915

Grip-On Discs.....926

Ground Clamps, Welding.....1086

Grounding Mats.....904

Grounds, Welding.....1086

Grounds Maintenance

- Broadcast Spreaders.....364, 370
- Cultivators.....368
- Forks.....367
- Garden Hose Hangers.....378
- Garden Hoses.....376-378
- Hedge Shears.....369
- Hoes.....368
- Ice Salt.....364
- Lopping Shears.....369
- Picks.....368, 1381
- Rakes.....367
- Shovels.....364-366, 368, 1381
- Sidewalk Scrapers.....368
- Spades.....366
- Sprayers.....320, 371-373
- Sprinklers.....376
- Tree Pruners.....369
- Tree Trimmers.....369
- Turf Edgers.....368
- Wheelbarrows.....172, 370

Guard Rails.....54, 84-85, 489

Guards

- Foot.....637
- Perimeter.....51, 84-85, 88
- Shin.....638
- Toe.....637

Guides, Welding.....1117

Gummed Tape.....1413

Gummed Tape Dispensers.....1411, 1413

Guns

- Air.....1035, 1051, 1225-1230
- Caulking.....1018, 1023-1024, 1035, 1045, 1161
- Garden Hose.....376-377
- Glue.....1035-1036, 1418
- Grease.....996-997, 1017, 1161, 1309
- Heat.....1190-1191
- MIG.....1094-1096
- Nail.....1163, 1446
- Paint.....1051
- Sandblasting.....1057, 1225
- Screw.....1187
- Soldering.....1080-1082

-H-

H.I.D. Lamps / Light Bulbs.....1529-1530

Hacksaws

- Blades.....1300
- Frames.....1300-1301, 1309-1312

Hair Nets.....526-527

Half Mask Respirators.....454-455, 458, 461-464, 469

Half Round Files.....1303

Half Round Rasps.....1305

Halogen Lamps / Light Bulbs

-219, 1524, 1527-1528, 1582

Hammer Bits.....1195-1196

Hammer Drill / Drivers.....1157-1159

Hammer Drills.....1158-1159, 1184-1187

Hammer Tackers.....1446

Hammers

- Air.....1213
- Anti-Vibration.....1364-1365
- Ball Pein.....1309-1312, 1362, 1365, 1380
- Blacksmiths'.....1366
- Brass.....1365
- Brick.....1364
- Chipping.....1087-1088
- Claw.....1309-1312, 1362, 1364, 1380
- Club.....369, 1365-1366

- Copper.....1365
- Dead Blow.....1309-1312, 1362-1363
- Demolition.....1187
- Double Faced.....1366
- Mallets.....1309, 1311, 1362-1363, 1380
- Non-Sparking.....1380, 1386
- Rotary.....1159, 1185-1187
- Scaling.....1364
- Sledge.....369, 1365-1366, 1380
- Soft Face.....1363

Hampers.....303

Hand Chisels.....1194, 1381

Hand Cleaners

- Cream.....331
- Foam.....325, 329, 332
- Gel.....315, 326, 328
- Liquid.....315, 326, 331
- Lotion.....315, 324, 326-329, 332

Hand Creams.....331, 333

Hand Crimpers, HVAC.....1359

Hand Dryers.....351

Hand Lamps.....1525-1528, 1531-1532

Hand Pad Holders.....933-934, 938

Hand Pads.....621, 1131

Hand Powered Drills.....1182-1183, 1186

Hand Pumps.....254-256, 258-259

Hand Reamers.....981

Hand Rollers.....799

Hand Sanitizer Dispensers.....323-324

Hand Sanitizers.....323-324, 333, 760

Hand Scrapers, Non-Sparking.....1382, 1386

Hand Scrubbers.....292, 302, 320

Hand Seamers, HVAC.....1359

Hand Shields, Welding.....1123

Hand Stamps.....795-796, 1117

Hand Taps.....956-960, 974-975, 977, 988

Hand Tools

- Arbor Presses.....208
- Auto Body Repair.....208
- Axes.....368
- Bolt Cutters.....1360-1361
- Cable Cutters.....1085, 1349, 1351-1352, 1361, 1377
- Chisels.....1088, 1194, 1309-1312, 1367-1370, 1381
- Clamps.....1238, 1284-1292
- Crowbars.....368, 1380
- Deburring.....1308
- Drywall Tools.....1052-1053, 1280, 1382, 1386
- Hammers.....369, 1309-1312, 1362-1366, 1380, 1386
- Hex Keys.....81, 1309-1312, 1346-1347, 1383
- Hooks & Picks.....1307
- Insulated Cutters.....1377
- Iron Shear Cutters.....1361
- Knives.....1355, 1371, 1382, 1386, 1440-1442
- Levels.....1115-1117, 1279, 1281-1283, 1461
- Locking Pliers.....1352
- Magnets.....286, 1086, 1297-1299
- Mallets.....1309, 1311, 1362-1363, 1380
- Multi-Purpose.....1355
- Nippers.....282, 383, 1357
- Non-Sparking.....1380-1383, 1385-1386
- Nut Drivers.....1342, 1378
- Paper Cutters.....1427, 1432-1433
- Pinch Bars.....1367, 1380
- Pipe Tools.....1115-1117, 1309, 1372-1374, 1378
- Pliers.....364, 1288, 1309-1312, 1348-1354, 1377, 1383, 1386
- Pry Bars.....1309-1312, 1340, 1366-1367, 1380, 1386
- Pullers.....1309-1310, 1312, 1368-1370
- Punches.....1309-1310, 1312, 1368-1370
- Ratchets.....1315-1322, 1324
- Rebar Cutters.....1361
- Rolling Head Bars.....1367
- Rotary Cutters.....1163
- Saws.....1300-1301, 1309-1312
- Scissors.....1356-1357, 1442, 1580
- Scrapers.....292, 298, 1382, 1386
- Screwdriver Bits.....1340, 1343-1345

Screwdrivers.....	1309-1312, 1338-1341, 1378, 1383, 1386	Hex Keys	81, 1309-1312, 1346-1347	HVAC		Impact Sockets	1323-1327
Sealing Spatula.....	1052	Non-Sparking.....	1383	Air Conditioners.....	1500	Impact Wrenches	
Shears.....	1356-1357	Hex Nuts	85, 89	Air Filters.....	359, 1058, 1500, 1506	Air.....	1205, 1208, 1210, 1214, 1222
Snips.....	1357-1359	Hex Square Drive Bits	1340, 1343	Air Purifiers.....	1500	Cordless.....	1159-1160
Socket Sets.....	1309-1315, 1325-1326	Hex Wrenches	1372, 1378	Axial Blowers.....	488-489	Electric.....	1181
Sockets.....	1309-1310, 1312-1327, 1385	Hexagonal Dies	978-979	Ceiling Fans.....	1498	Incandescent Lamps / Light Bulbs	1525-1526, 1528, 1532, 1582
Squares.....	1280-1281	High Heat Coating	1042-1043	Ceiling Mounted Heaters.....	1504	Indigestion Relievers	752
Technicians'.....	1309-1312, 1378-1379	High Heat Paint	1042-1043	Centrifugal Blowers.....	489	Indoor / Outdoor Thermometers	1472
Tubing Cutters.....	1374	High Temperature Greases	1017	Drum Fans.....	1497, 1502	Industrial Cleaners	
Vises.....	1293-1296	High Visibility Clothing		Exhaust Fans.....	1501	Aluminum.....	1145
Wedge.....	1381	Hat/Toque.....	549	Fan Forced Heaters.....	1503, 1505	Bleach.....	314
Wrecking Bars.....	1366	Jackets.....	547-548	Fan Guards.....	489	Boot and Shoe.....	889
Wrenches.....	960, 977, 1309-1312, 1330-1337, 1384-1386	Overalls.....	543	Floor Fans.....	1499	Brake.....	1005, 1015
Hand Towels	334, 340-344, 384, 1005, 1583	Pants.....	548, 551	Fume Extractors.....	1058-1060	Carpet.....	317
Hand Truck Step Ladder	1581	Parkas.....	547	Fume Filters.....	1058-1059	Coil Cleaner.....	1005
Hand Trucks	144-146, 148-151, 1454, 1554	Rain Jackets.....	543	Hand Crimpers.....	1359	Dish Detergents.....	316
Hand Warmers	629	Rain Suits.....	543	Hand Seamers.....	1359	Disinfectants.....	313-314, 318, 759-760
Hand Winches	195	Sweatshirts.....	547	Humidifiers.....	1500	Drain.....	316
Handles		T-Shirts.....	547	Mechanical Filters.....	1059	Floor.....	310-311, 317
File.....	1307	Vests.....	545-547	Office Fans.....	1499	Food Grade.....	1004
Torch.....	1065	High Voltage Gloves	558-559	Pedestal Fans.....	1497-1499	Furniture Polish.....	319
Handling Labels	1430, 1448	Hi-Liters	1578	Portable Blowers.....	359, 488, 1059-1060	Glass.....	315, 1004
Hangers		Hinges, Weld-On	1088	Portable Heaters.....	1504	Graffiti Removers.....	319, 1005, 1043
Clothes.....	1581	Hip Waders	633	Radiant Heaters.....	1503-1505	Heavy-Duty.....	1037
Garden Hose.....	378	Hoes	368	Radiator Heaters.....	1503	Machine.....	320
Merchandise Display.....	1435	Hoist, Rescue	492	Smoke Ejectors.....	1501	Multi-Purpose.....	312-316, 319, 1003-1004, 1037
Hanging Scales	203, 1493-1494, 1496	Hoists		Tent Heaters.....	489	Non-Chlorinated.....	1020, 1144
Hard Hat Lanyards	420, 522, 524	Air.....	191	Wall Heaters.....	1504	Oven.....	316
Hard Hat Liners, Cooling	646	Electric.....	191	Wall Mounted Fans.....	1497-1499	Rust Removers.....	1014, 1146
Hard Hats	414-418	Manual.....	190-191, 199	Hydration Backpack	647	Scouring Powder.....	316
Hardness Testers		Hold-Down Clamps	1290-1292	Hydrogen Peroxide	734, 748, 759	Stainless Steel.....	316, 319, 1004
Non-Metals.....	1479	Holders		Hydrophobic Coating	638, 1045	Toilet Bowl.....	314
Steel & Alloys.....	1479	Cell Phone.....	443, 1387, 1390	Hygienic Products		Urinal.....	349
Hardware		Chisel.....	1367	Basins.....	731, 734, 751, 758	Industrial Jacks	207
Shims.....	1273-1274	Electrode.....	1084	Sanitary Napkins.....	348-349	Inflator Gauges, Tire	1224
Stock.....	1274	Gloves.....	593, 629	Shampoo.....	325, 329	Information Centers, MSDS	848-849
Harnesses		Hand Pad.....	933-934, 938	Tampons.....	348	Information Centres	
Arc Rated.....	500, 560	TDG.....	851	Hygrometers, Thermo	1474, 1476	GHS.....	848
D-Ring.....	495	Tool.....	986			SDS.....	848-849
General.....	141, 494-499, 501-502, 519	Tool Storage.....	1387-1388, 1392	I-Beam Frame Levels	1281	Information Charts	
Traffic Control.....	548	Hole Saw Arbors	1193, 1198	Ibuprofen	752	GHS.....	847
Welding.....	496, 500	Hole Saws	1197-1198	Ice Cleats	636	WHMIS.....	847
Hasp Lockouts	764, 768-769, 780	Hoop, Respirators	473, 479, 1127	Ice Salt	364	Infrared Thermometers	1469-1470
Hats		Hoods		Ice Spikes	636	Inhalants, Ammonia	734, 763
Cooling.....	645	Arc Flash.....	556-557	Identification		Ink, Stencil	799
Hard.....	414-418	Flame Resistant.....	556-557	Fountain Brushes.....	799	Ink Stencils	797
Hawks	1053	General Protection.....	527, 534	Fountain Rollers.....	799	In-Line Drills, Air	1209, 1221
Hazardous Materials Cabinets	658, 660-667	Rain.....	541-543, 548	GHS Products.....	844, 847	In-Line Filters	1251, 1256
Hazardous Materials Signs	808	Hook & Loop Fasteners	1577	Grease Pencils.....	1142, 1445	In-Line Lubricators	1251, 1256, 1261
Head Assemblies, MIG Gun	1095	Hooks		Hand Rollers.....	799	In-Line Regulators	1232, 1256, 1261
Headbands, Cooling	645, 647	Clevis Grab.....	192-193	Hand Stamps.....	795-796, 1117	Insect Repellent	335, 384
Headgear, Respirators	473, 479, 1127	Clothes.....	350	Label Holders.....	5, 12, 48, 72-73, 1571	Insect Sting Relief	749
Headlights, Hard Hat	419, 549	Drum Lifting.....	243	Label Makers.....	5, 12, 824-830, 1572-1574	Inserts, Pail	235
Headsets	435, 438-439	Lifting.....	192-193	Labels.....	818-819, 844-845	Insoles	638
Hearing Bands	430-431	Sky.....	199	Lumber Crayons.....	1142, 1444	Inspection Cameras	1376, 1485
Heat Guns	1190-1191	Slip.....	192-193	Marking Flags.....	871	Borescope.....	1485
Heat Resistant Clothing		Hooks & Picks	1307	Metal Markers.....	1444	Inspection Gloves	625
Aprons.....	551	Hoppers, Self-Dumping	171	MSDS Products.....	667, 848-849	Inspection Mirrors	883
Coats.....	551	Horizontal Sheet Rack	53	Paint Markers.....	1142, 1442-1444	Instant Adhesives	1031-1032
Leggings.....	551	Horns	221	Paint Sticks.....	1142, 1443-1444	Instrument Tray	751
Heat Resistant Gloves	605, 622-624	Signal.....	444	Pipe Markers.....	833-841	Instruments	
Heat Resistant Mitts	622	Hose Clamps	1238	Safety Whips.....	856	Anemometers.....	1486-1487
Heat Stress Meter	645, 1475	Hose Fittings	1234, 1239, 1247, 1250	SDS Products.....	847-849	Balometers.....	1488
Heaters		Welding.....	1074	Self-Adhesive Letters.....	800	Bi-Metal Thermometers.....	1473
Ceiling Mounted.....	1504	Hose Protectors, Dock	217	Self-Adhesive Numbers.....	800	Borescope.....	1485
Drum.....	237	Hose Reel Carts	1237	Signs.....	12, 48, 210, 308, 653, 727, 758, 803-817, 820-823, 849, 851, 857-859	Cable Tracers.....	1468, 1543
Fan Forced.....	1503, 1505	Hose Reels	1076, 1234-1237, 1532	Snow Flags.....	871	Calipers.....	1275, 1309-1310
Pail.....	237	Hose Repair Kits	377	Soapstone.....	1143	Circuit Testers.....	1461, 1539
Portable.....	1504	Welding.....	1075	Stencil Inks.....	799	Clamp Meters.....	1460-1461, 1466, 1468, 1540
Radiant.....	1503-1505	Hose Whips	1250	Stencils.....	797-798	Conductivity Meters.....	1490
Radiator.....	1503	Hoses		Tags.....	12, 786-788, 790-793, 1448	Cooking Thermometers.....	1471, 1473
Tent.....	489	Air.....	1207, 1233-1235	Tape.....	811, 868-870	Counters.....	1483
Wall.....	1504	Discharge.....	263	TDG Products.....	851-854	Digital Thermometers.....	1472-1473
Heating Tips	1072	Drench.....	726	WHMIS Products.....	845-847	Distance Measurers.....	1276-1279, 1309-1312, 1482, 1484
Hedge Shears	369	Garden.....	378	Windsocks.....	871	Feeler Gauge Stock.....	1274
Helmets, Welding	481, 1121-1127	Loc-Line®.....	1150-1153	Illuminometers, Digital	1481	First Aid.....	729-735, 747, 751, 756
Hex Bit Sockets	1315-1316	Lubricant.....	996	Impact Gloves	605-607, 644	Force Gauges.....	1484
Hex Bits	1344	Welding.....	1068, 1075, 1110	Impact Labels	1430	Gas Detectors.....	482-487, 1474
		Hot Compresses	731-732, 734, 750			Hardness Testers.....	1479
		Humidifiers	1500				
		Humidity Labels	1429				
		Humidity Meters, Infrared	1475				



Heat Stress Meter.....	645, 1475	Pipe.....	1115	Straws.....	1583	Laminators, Document	1574
Humidity Meters.....	1475	Trailer.....	212	Table Caddies.....	1557	Lamps	
Hygrometers.....	1474, 1476	Janitorial Products		Tables.....	382, 1556-1557	Desk.....	1524, 1582
Illuminometers.....	1481	Broom & Mop Racks.....	286	Kits		Floor.....	1527
Indoor / Outdoor Thermometers.....	1472	Brooms.....	287-290, 301	Airway.....	763	Fluorescent.....	1524-1526, 1529-1530, 1582
Infrared Thermometers.....	1469-1470	Brushes.....	26, 291-292, 300-301,	Auto Body Repair.....	208	H.I.D.....	1529-1530
Inspection Cameras.....	1376, 1485	349, 946, 1383, 1386	Burn Care.....	753	Halogen.....	219, 1524, 1527-1528, 1582
Inspection Mirrors.....	883	Buckets.....	305-307	CPR.....	763	Incandescent.....	1525-1526, 1528, 1532, 1582
Insulation Testers.....	1467	Buckets / Wringers.....	306-307	Fall Protection.....	505-507	LED.....	219
LCR Meters.....	1468	Burnishing Pads.....	362	First Aid.....	729-739, 745	Lanterns	
Light Meters.....	1481	Carts.....	275, 309	Laser Distance.....	1482	6 V.....	1517
Magnifiers.....	1524	Cleaning Pads.....	292, 294, 302, 320, 362	Lockout.....	772, 777-779	Cordless.....	1516
Manometers.....	1487-1488	Cloths.....	293-294	Power Tool Combo.....	1164-1166	Waterproof.....	1518
Micrometers.....	1275	Dusters.....	294, 302, 320	Spill Control.....	689-698, 760	Lanyards	
Moisture Meters.....	1477	Dustpans.....	290, 296, 687	Welding Torch.....	1064, 1109	Arc Rated.....	510, 560
Motor Rotation Testers.....	1468	Extension Poles.....	287-288, 292-294,	Knee Boots	631-632	Eyewear.....	408
Multi-Function Testers.....	1462	297-299, 302, 1048	Knee Pads		Hard Hat.....	420, 522, 524
Multimeters.....	1460, 1462	Funnels.....	317, 993-994	Co-Polymer / Ester Tricot.....	639	Positioning and Restraint.....	508
Oral Thermometers.....	756	Hand Towels.....	Foam.....	640	Self-Retracting.....	492, 512-513, 515
ORP Meters.....	1490	334, 340-344, 384, 1005, 1583	Foam / Hard Shell.....	640	Shock Absorbing.....	141, 507-510
pH Meters.....	1490	Liquid Measures.....	993	Gel.....	639-640	Tie-Back.....	509-510
Phase Rotation Testers.....	1468	Measuring Cups.....	317, 994	Hard Shell.....	640	Tool.....	522-524
Pocket Gauges.....	1275	Mops.....	292-295, 304-306	Leather.....	1133	Welding.....	510
Porosity Detectors.....	1478	Pressure Washers.....	374-375	Rubber.....	640	Laser Distance Kits	1482
Pressure Gauges.....	1068, 1224, 1232, 1489	Scoops.....	363, 366, 694, 994	Knelling Pads	639	Laser Levels	1282-1283, 1461
Psychrometers.....	1475	Scrubbers.....	292, 302, 320	Knit Gloves	626, 629	Latch Clamps	1290-1292
Refractometers.....	1490	Squeegees.....	296-299, 301, 687	Knives		Latex Coating	1042
Scales.....	203, 1433, 1491-1496	Sweepers.....	286, 358	Cafeteria.....	1583	Latex Paint	1042
Sound Level Meters.....	440, 1480-1481	Trigger Sprayers.....	302, 320	Curved Blade.....	1382, 1386	Laundry Equipment	
Stem Thermometers.....	1473	Vacuum Cleaners.....	352-361, 688, 1225	Drywall.....	1052-1053, 1382, 1386	Bags.....	303
Stopwatches.....	645, 1475, 1483	Washroom Products.....	314, 321-322,	Flooring.....	1441	Carts.....	303
Stroboscopes.....	1483	340-351, 1375, 1583	Linoleum.....	1382, 1441	Detergents.....	317
Surface Mount Thermometers.....	1473	Waste Management.....	169, 236, 266-285,	Packaging.....	1309, 1312, 1425,	Hampers.....	303
Tachometers.....	1482	290, 348-350, 383, 657, 761, 1037, 1577	1430, 1434, 1438-1442	Ironer Trucks.....	303
Temperature Probes.....	1471, 1475, 1488	Water Brooms.....	377	Pocket.....	1355	Linen Trucks.....	303
Temperature Recorders.....	1476	Window Washers.....	299	Putty.....	1052, 1382, 1386	Lava Nozzles	1105
Thermal Cameras.....	1470	Wipes.....	316, 318, 332, 334-339,	Roofing.....	1441	Layout Fluids	1145, 1148
Thermocouple Thermometers.....	384, 465, 759-760, 1054	Rubber Cutting.....	1371, 1441	L-Clamps	1284
.....	1429, 1471, 1474-1475	Wipes Dispensers.....	334, 336, 338-340	Straight Blade.....	1382, 1386	LCR Meters	1468
Thermometer / Hygrometers.....	Wringers.....	294, 307	Utility.....	1382, 1440-1442	Leads, Test	1463
.....	645, 1472, 1474-1476	Jars, Storage	28	Knockout Tools	1162	Leak Diverters	683
Thickness Gauges.....	1478-1479	Jelly, Petroleum	749	Kraft Paper	1428, 1430	Leak Plug	683
Time Clocks.....	1575	Jerry Cans	671-672	Leak Seal	683	Leather Gloves	
Timers.....	378, 1483	Jersey Gloves	628-629	608-613, 618, 621, 1131, 1310-1311	LED Lamps / Light Bulbs	219
Torque Meters.....	1329	Jib Booms	201	Lab Coats	550	Leg / Arm Bands, Traffic Control	548
Torque Multipliers.....	1328	Jib Cranes	201	General Protection.....	531-534, 536, 539	Leggings, Heat Resistant	551
Torque Screwdrivers.....	1329	Jig Saws		Label Holders	5, 12, 48, 72-73, 1571	Lens Cleaners	
Torque Wrenches.....	1328	Heavy-Duty.....	1178	Label Makers		Solutions.....	409
Vibration Meters.....	1484	Orbital.....	1178	Accessories.....	5, 12, 825, 827-828	Stations.....	409
Voltage Testers.....	1462, 1543	Jiggers	144, 182-186	Portable.....	824-825, 827, 1572-1574	Tissues.....	409
Wall Clocks.....	1575	Jobsite Boxes	36, 1394, 1401-1407	Ribbons.....	824-828, 830, 1573	Towellettes.....	409, 465, 760
Insulated Cutters	1377			Software.....	1574	Lenses, Filter Plate	1122, 1128
Insulation Testers	1467			Table Top Versions.....	828, 1572-1573	Letters, Self-Adhesive	800
Insulator Caps, MIG Gun	1098			Tapes.....	825-826, 828-830, 1572-1574	Levelers, Dock	214
Insulators, TIG Torch	1108			Labels		Leveling Mounts	1272
Integral Probe Anemometers	1486-1487			GHS Safety.....	844-845	Levels	
Iron Shear Cutters	1361			Handling.....	1430, 1448	Chalk Lines.....	1279
Ironer Trucks	303	Keel Klamp® Pipe Fittings	79-81	Humidity.....	1429	I-Beam Frame.....	1281
Irons, Soldering	1080-1082	Keel Klamp® Piping	81	Impact.....	1430	Laser.....	1282-1283, 1461
ISO Safety Labels	818-819, 845	Key Boxes	654	ISO Safety.....	818-819, 845	Pipefitting.....	1115-1117
Isolators, Vibration	1272	Key Cabinets	1570	Lock.....	770	Plumb Bobs.....	1279, 1283
Isopropyl Rubbing Alcohol	748	Key Chains	1570-1571	TDG.....	855, 1448	Pocket.....	1115
		Key Racks	1570	Temperature.....	1429	Torpedo.....	1281
		Key Rings	794	WHMIS.....	846	Lever Pumps	256
		Key Tags	1570	Ladder, Step Stool Hand Truck	1581	Lids.....	266, 268, 271-272, 276-277
		Keyboard Trays	1558	Ladder Trucks	134	Drum.....	236, 670, 699
		Keyboard Wrist Rests	1558	Ladders		Pail.....	236
		Keys, Hex	81, 1309-1312, 1346-1347, 1383	Crossover.....	140	Waste Container.....	266, 268, 271-272, 276-277
		Keys, Hex	81, 1309-1312, 1346-1347, 1383	Double Stepladders.....	129-131	Life Lines	
		Kitchen Supplies		Escape.....	656	Self-Retracting.....	492, 512-515, 518
		Aluminum Foil.....	1583	Extension.....	132-133, 135	Vertical.....	517, 520
		Cling Wrap.....	1583	Multi-Purpose.....	131-132, 1150	Lift Tables	178-179, 181, 184
		Coffee Equipment.....	1583-1584	Platform.....	127, 129-131, 135	Lifters	
		Coolers.....	1586	Rolling.....	135, 137-140	Drum.....	238-243, 701
		Cup Dispensers.....	1583	Single.....	127, 132-133	Shop.....	180, 703
		Cups.....	1583	Stairway.....	140	Lifting Equipment	
		Forks.....	1583	Stepladders.....	127-128, 134-135	Aircraft Cables.....	194
		Knives.....	1583	Stepstands.....	135-137	Beam Clamps.....	199, 519
		Microwave Ovens.....	1584	Stepstools.....	134, 136, 1549	Beam Trolleys.....	190, 519
		Napkin Dispensers.....	343-344, 1583	Trestle Stepladders.....	129-131	Chain.....	193
		Napkins.....	343-344, 1583				
		Plates.....	1583				
		Refrigerators.....	1584				
		Spoons.....	1583				
		Stirring Sticks.....	1583				

Clevis Grab Hooks.....192-193
 Cranes.....200-202, 208
 Engine Tilters.....208
 Hoists.....190-191, 199
 Hooks.....192-193
 Jacks.....206-208, 212
 Jibs.....201
 Lift Tables.....178-179
 Lifting Clamps.....198
 Magnetic Lifters.....196, 198, 1298
 Manhole Lid Lifters.....489
 Pallet Lifters.....181, 184, 201
 Pallet Trucks.....144, 182-186
 Skid Lifts.....181, 184
 Sky Hooks.....199
 Slings.....188-189
 Slip Hooks.....192-193
 Stackers.....180, 703
 Vacuum Cups.....196-197

Light Bulbs
 Fluorescent.....1524-1526, 1529-1530, 1582
 H.I.D.....1529-1530
 Halogen.....219, 1524, 1527-1528, 1582
 Incandescent.....1525-1526, 1528, 1532, 1582
 LED.....219

Light Fixtures.....1520
Light Meters, Digital.....1481
Lighters, Flint.....1073

Lighting
 Bay Lights.....1520
 Desk Lamps.....1524, 1582
 Dock Lights.....218-220
 Emergency Lights.....1521-1522
 Exit Lights.....1521
 Flashing Lights.....222-223, 863, 866
 Flashlight Belt Holsters.....1509-1511
 Flashlights.....1162, 1509-1519
 Floodlights.....1162, 1520, 1526-1528, 1530
 Floor Lamps.....1527
 Hand Lamps.....1525-1528, 1531-1532
 Headlights.....419, 549
 Lamps / Light Bulbs.....219, 1524-1530, 1532, 1582
 Lanterns.....1516-1518
 Lightsticks.....858, 860
 Penlights.....1512
 Spot Lights.....187, 1516, 1518
 String Lights.....1528
 Task Lights.....1523, 1529-1530
 Telescopic Lights.....1528
 Traffic Wands.....1509
 Warning Lights.....222-223, 863, 866

Lighting Baton.....858, 860
Lightsticks.....858, 860

Limited Use Clothing
 Aprons.....529-531, 533-534
 Coveralls.....532-533, 535-539, 689-693, 697
 Hoods.....527, 534
 Lab Coats.....531-534, 536, 539
 Pants.....534
 Shirts.....534

Line Stripping Paint.....1039
Lineman's Pliers.....1309-1312, 1348
Linen Trucks.....303

Liners
 Container.....280
 Drum.....235
 Gaylord.....4, 280
 Hard Hat.....418, 553
 MIG Gun.....1095-1097
 Waste Container.....267, 269-270, 273, 285

Linoleum Knives.....1382, 1441
Lip Balm.....335, 384, 750
Liquid Measures.....993
Liquid Tip Markers.....846, 1445, 1578
Literature, First Aid.....729-735
Literature Displays.....1568
Litter Pickers.....282, 383
Litter Scoops.....282, 290, 383
Load Binders.....192
Lock Labels.....770
Locker Room Benches.....108, 382

Lockers
 Plastic.....109-110
 Steel.....104-108

Locking Pliers.....1288, 1309-1312, 1351-1354

Lockouts
 Ball Valve.....780, 782-784
 Butterfly Valve.....783
 Cable.....779
 Circuit Breaker.....781-782
 Confined Space.....784
 Electrical Plug.....781-782
 Electrical Switch.....781
 Gas Cylinder.....106
 Gate Valve.....784
 Hasps.....764, 768-769, 780
 Kits.....772, 777-779
 Pneumatic Fitting.....1250
 Pump.....259
 Stations.....772-779
 Tags.....786-790

Lockouts Dielectric, Hasps.....780

Locks
 Dielectric Padlocks.....769
 Padlocks.....99, 110, 764-772
 Wheel.....782

Loc-Line® Hosing.....1150-1153

Logistic Straps.....246, 1456
Logistic Tracks.....212, 1457

Long Nose Pliers.....1309-1312, 1348, 1351, 1377

Loosefill.....1428

Lopping Shears.....369

Lotions, Body.....749

Loudspeakers.....444

Lubricants
 Air Tool Oil.....1037, 1261
 Anti-Seize.....1016
 Bearing Greases.....1017
 Cutting Fluids.....1148-1149
 Dielectric Greases.....1018
 Dry.....1008-1010, 1012
 Food Grade.....1008, 1010-1011, 1018
 Freeze Spray.....1006
 General Purpose.....1013
 Graphite.....1008
 High Temperature Greases.....1017
 Layout Fluids.....1145, 1148
 Machinery Oil.....1011
 Mold Release.....1009
 Multi-Purpose Greases.....1011, 1018
 Penetrants.....1004, 1012-1013, 1020, 1144
 Pump.....1144
 Silicone.....1008, 1010
 Spray.....1008-1013, 1018
 Synthetic.....1009, 1012
 Synthetic Greases.....1018
 Tapping Compounds.....1149
 White Lithium.....1018
 White Lithium Greases.....1018
 Wire Pulling.....1012, 1543

Lubricating Equipment
 Control Valves.....1000
 Fittings.....999-1001
 Grease Guns.....996-997, 1017, 1161, 1309
 Grease Pumps.....999-1000
 Hoses.....996
 Loc-Line Hosing.....1150-1153
 Oil Cans.....999

Lubricators, In-Line.....1251, 1256, 1261
Lugs, Welding Cable.....1085

Lumber Carts.....159-160
Lumber Crayons.....1142, 1444



Machine Cleaners, Heavy-Duty.....320
Machine Stands.....120
Machine Taps.....976
Machine Tool Pumps.....1150
Machine Vises.....1295
Machine Wrap.....1426

Machinery
 Bandsaws.....1178
 Drilling Machines.....1188-1189, 1266-1267
 Rollers.....204-205
 Sandblasting Equipment.....1055-1057, 1225
 Shrink Wrap.....1426

Machinery & Operations Signs.....804-805, 809

Machinery Oil.....1011
Machinery Rollers.....204-205
Magnetic Brooms.....290
Magnetic Lifters.....196, 198, 1298
Magnetic Retrievers.....1297-1298
Magnetic Tags.....12

Magnets
 Bar.....1298
 Ceramic.....1299
 Cup.....1299
 Print Holders.....1298
 Rare Earth.....1299
 Retrievers.....1297-1298
 Strip.....1298
 Sweeper.....286
 Welding Grounds.....1086
 Welding Squares.....1086

Magnifier Plates.....1126, 1128

Magnifiers
 Illuminated.....1524
 Lenses.....1524

Mail Sorters.....1566
Mailboxes.....1576
Mailers.....1434-1435
Maintenance Brushes.....26, 300-301, 1383, 1386
Maintenance Platforms.....141
Maintenance Signs.....808-809, 813
Mallets.....1309, 1311, 1362-1363, 1380
Manhole Lid Lifters.....489
Manhole Shields.....489, 491
Manifolds, Air.....1250
Manometers.....1487-1488
Marine Jacks.....207

Markers
 Liquid Tip.....846, 1445, 1578
 Lumber Crayons.....1142, 1444
 Metal.....1444
 Office.....823, 846, 1442, 1445, 1569, 1578
 Paint.....1142, 1442-1444
 Paint Sticks.....1142, 1443-1444
 Permanent.....1442, 1445, 1578
 Pipe.....833-841
 Pipe Contour.....1116-1117
 Soapstone.....1143
 Whiteboard.....823, 1569

Marking Flags.....871
Marking Paint.....1038, 1040
Marking Paint Applicator.....1040
Marking Wands.....1038-1040
Masking Tape.....1414
 Painter's.....1050

Masks
 CPR.....729-730, 762-763
 Dust.....447, 453

Material Handling
 Box Trucks.....166, 172-175
 Cargo Bars.....212, 1457
 Carts.....660, 662
 Conveyors.....224-225
 Decking & Shoring Beams.....212, 1457
 Dollies.....20, 97, 103, 176-177, 208-209, 1078
 Drywall Carts.....159
 Engine Stands.....208
 Forklift Bump Guard.....186
 Forklift Checklist Kit.....187
 Forklift Extensions.....141, 187, 242
 Forklift PPE Battery Kit.....186
 Gas Cylinder Trucks.....1078
 Hand Trucks.....144-146, 148-151, 1454, 1554
 Hoppers.....171
 Lifting Equipment.....144, 178-202, 206-208, 212, 489, 519, 703, 1298
 Load Binders.....192

Lumber Carts.....159-160
 Pallet Turntables.....181
 Panel Trucks.....158-160
 Pipe Trucks.....160-161
 Platform Trucks.....152-158, 160, 165
 Reel Dispensers.....167
 Reel Racks.....78
 Security Carts.....77
 Semi-Live Skids.....154, 158
 Shop Carts.....7-8, 42, 73, 76-77, 161-170
 Stands.....207, 209
 Step Ladder Hand Truck.....1581
 Stock Trucks.....166
 Tilt Trucks.....172-173
 Tricycles.....161
 Wagons.....154, 157, 370
 Winches.....195
 Wire Spool Carts.....167
 Work Positioners.....181
 Work Stands.....209, 225

Mats, Grounding.....904

Matting
 Anti-Fatigue.....891-894, 896-897, 899-900, 902-909
 Anti-Static.....560, 903-904
 Clean Room.....907
 Eco.....886
 Entrance.....874, 885-888, 901, 909
 Eyewash Stations.....727, 893
 Runner.....885-888, 901, 909
 Welding.....904, 1119
 Wiper.....874, 885-887

Measurement Devices
 Laser Distance Kits.....1482
 Measuring Counters.....1484
 Tape.....1276-1279, 1309-1312
 Wheels.....1278, 1482, 1484
 Wire Measurers.....1484

Measures, Liquid.....993
Measuring Counters.....1484
Measuring Cups.....317, 994

Measuring Tape
 Oil Gaging.....1279
 Reel.....1279
 Retractable Blade.....1276-1278, 1309-1312

Measuring Wheels.....1278, 1482, 1484
Mechanical Filters.....1059
Mechanic's Dollies.....209
Media, Sandblasting.....1055
Media Recyclers, Sandblasting.....1055-1056

Medicine
 Acetaminophen.....752
 Antacids.....752
 Cough and Cold Relief.....752
 Ibuprofen.....752

Megaphones.....444
Mesh Enclosures.....90
Mesh Partitions.....51, 84-85, 88-89
Message Pads.....1579
Metal Markers.....1444
Metal Snips.....1357-1359
Metal Working Fluids.....1145, 1148-1149
Microfiber Cloths.....293-294
Micrometer, Vernier.....1275
Micrometers, Digital.....1275
Microwave Ovens.....1584
MIG Guns.....1094-1096
MIG Pliers.....1088
MIG Welders.....1092-1093

MIG Wire
 Aluminum.....1138
 Bronze.....1138
 Copper.....1138
 Steel.....1135, 1137

Mini Die Grinders, Air.....1215

Mirrors
 Bathroom.....350
 Convex.....882
 Dome.....881, 883
 Flat.....882
 Inspection.....883

INDEX

Rectangular.....	882
Round.....	882
Mitre Saw Blades	1203
Mitre Saws	1175-1176
Mitts, Heat Resistant	622
Mixers	
Drum.....	249
Pail.....	249
Paint.....	1046
Mixing Valves, Thermostatic	721
Mobile Bins	6
Moisture Meters	1477
Mold Release Lubricants	1009
Monitor Mounts	1558
Monitor Stands	1577
Mops	
Cotton.....	304-305
Dust.....	293, 295
Microfibre.....	295
Poly / Mesh.....	305
Polyester / Rayon.....	304
Sponge.....	292-293
Wet.....	292-295, 304-306
Motor Oil	1015
Motor Rotation Testers	1468
Motors, Coring	1189
Mounts	
Cupmounts.....	1272
Leveling.....	1272
Monitor.....	1558
Moving Supplies	
Cargo Nets.....	1455
Jack Bars.....	1457
Logistic Tracks.....	212, 1457
Moving Blankets.....	1454
Straps.....	150, 246, 1454-1456
Tie-Downs.....	683, 1455-1457
MSDS	
Binders.....	849
Information Centers.....	848-849
Storage Boxes.....	667
Muffs	
Cap Mounted.....	433-439
Headband.....	433-438, 549
Headstrap.....	433-438, 549
Hearing.....	435
Neckband.....	434, 436-437
Multi-Gas Detectors	482-486
Multi-Gas Meters	483
Multimeters	
AC/DC.....	1460, 1462
Electrical.....	1460
True RMS.....	1460
Multi-Purpose Greases	1011, 1018
Multi-Purpose Hand Tools	1355
Multi-Purpose Ladders	131-132, 1150
Multi-Tip Screwdrivers	1340-1341
-N-	
Nail Guns	
Cordless.....	1163
Electric.....	1446
Nails, for Nail Guns	1446
Napkin Dispensers	343-344, 1583
Napkins	
Cafeteria.....	343-344, 1583
Sanitary.....	348
Neck Protectors, Welding	1125
Neck Shades, Cooling	647
Needle Nose Pliers	1349, 1351
Nesting Bins	18-19, 26
Nets	
Cargo.....	1455
Hair.....	526-527
Neutralizers	
Battery Acid.....	686, 1037
Spill Control.....	686, 697
Newsprint	1428
Nibblers	1173
Nippers, End Cut	282, 383, 1357

Nipples, Pipe Thread	1240, 1243-1244
No Smoking Signs	806-808, 810
Non-Aqueous Developers	1144
Non-Chlorinated Cleaners	1020, 1144
Non-Chlorinated Degreasers	1144
Non-Chlorinated Developers	1020, 1144
Non-Sparking Tool Kits	1386
Non-Sparking Tools	
Chisels.....	1381
Hammers.....	1380, 1386
Hex Keys.....	1383
Mallets.....	1380
Pliers.....	1383, 1386
Scrapers.....	1382, 1386
Sockets.....	1385
Spatulas.....	1382
Wedge.....	1381
Wrenches.....	1384-1386
Nose Cutting Pliers	1350, 1353
Nozzle Cleaners	1143
Nozzle Gels, MIG Gun	1145
Nozzle Reamers	1088
Nozzles	
Garden Hose.....	376-377
MIG Gun.....	1095-1098
TIG Torch.....	1104-1106
Numbered Tags	793
Numbers, Self-Adhesive	800
Nut Drivers	
Cushion Grip.....	1342
Hollow Shaft.....	1342
Insulated.....	1378
Magnetic.....	1342
Sets.....	1342
Nuts, Hex	85, 89
Nutsetters	1343

-O-

Odour Neutralizers, Footwear	750
Office, Dry Erase Whiteboard Wipes	1569
Office Desks	1567
Office Fans	1499
Office Seating	1546, 1548-1549, 1553-1554
Ergonomic.....	1547-1549, 1554
Office Supplies	
Binders.....	1579
Clipboards.....	1579
Corkboards.....	1569
Desk Organizers.....	1577
Directory Boards.....	1569
Display Hangers.....	1435
Dry Erase Whiteboard Wipes.....	1569
File Folders.....	1564, 1579
Filing Boxes.....	1564
Grounding Mats.....	904
Hi-Liters.....	1578
Literature Displays.....	1568
Markers.....	823, 846, 1442, 1445, 1569, 1578
Message Pads.....	1579
Monitor Mounts.....	1558
Paper Clamps.....	1565
Paper Clips.....	1580
Pencil Sharpeners.....	1578
Pencils.....	729, 732-733, 1578
Pens.....	1578
Printer & Photocopier Paper.....	1579
Push Pins.....	1569
Rubber Bands.....	1423, 1580
Sheet Protectors.....	1579
Staples.....	1446
Suggestion Boxes.....	1581
Tape.....	1580
Tape Dispensers.....	1580
Whiteboards.....	1569
Offset Wrenches	1373
Oil	
Air Tool.....	1037, 1261
Machinery.....	1011
Oil Cans	999

Oily Waste Cans	670-671
Ointments, Burn Care	749
Omni-Directional Stands	225
Open End Wrenches	1335
Open Wire Workstations	118
Openers, Pail	250
Oral Thermometers	756
Orbital Sanders, Air	1207, 1211-1212, 1218-1219
Order Picking Carts	165
O-Rings, MIG Gun	1095
ORP Meters	1490
Oscillators, Garden Hose	376
Outdoor Equipment	
Bicycle Racks.....	379
Grounds Maintenance.....	172, 320, 364-373, 376-378, 1381
Park Benches.....	380
Picnic Tables.....	380
Snow Removal.....	364, 871
Outfits, Welding	1062-1064
Outlet Adaptors, GFCI	1540
Outlet Boxes, GFCI	1539
Oval Sleeves	194
Oven Cleaners	316
Ovens, Electrode	1089
Overalls	
Arc Flash.....	555-556
Flame Resistant.....	555-556
Rain.....	542
Overboots	633
Overpack	689-690, 693, 697, 700-702, 713
Overshoes	633-634
Oxygen Hoses, Welding	1075
Oxygen Masks, Kits	763

-P-

Packaging	
Benches.....	1433
Boxes.....	1431
Bubble Pouches.....	1435
Bubble Wrap.....	1427
Bungee Cords.....	1455, 1457
Cable Tie Tools.....	1452
Cable Ties.....	793-794, 1435, 1452
Corrugated Paper.....	1430
Desiccants.....	1429
Edge and Corner Protectors.....	48, 86-87, 216, 1421, 1423
Flexible Netting.....	1430
Foam.....	1427
Handling Labels.....	1429-1430, 1448
Knife Blades.....	1425, 1430, 1434, 1438-1442
Knives.....	1309, 1312, 1425, 1430, 1434, 1438-1442
Kraft Paper.....	1428, 1430
Loosefill.....	1428
Mailers.....	1434-1435
Moving Straps.....	150, 246, 1454-1456
Newsprint.....	1428
Packing List Envelopes.....	1449
Pads.....	1431
Poly Bags.....	1436
Poly Tubing.....	1430, 1437
Rope.....	1450
Shrink Wrap.....	1426
Shrink Wrap Machines.....	1426
Staple Removers.....	1447
Staplers.....	1446-1447
Staples.....	1446-1447
Strapping.....	1419-1422
Stretch Wrap.....	1424-1426
Stretch Wrap Dispensers.....	1424-1426
Tape.....	829, 1410-1416, 1429, 1436
Tape Dispensers.....	1411-1413, 1416, 1429
TDG Labels.....	855, 1448
Temperature Labels.....	1429
Tie-Downs.....	683, 1455-1457

Tissue Paper.....	1428
Twine.....	1450
Packing List Envelopes	1449
Padlock Caddy	773
Padlocks	99, 110, 764-772
Pads	
Anti-Vibration.....	1272
Backing.....	921-922, 925, 927, 935
Burnishing.....	362
Cleaning.....	292, 294, 302, 320, 362
Corrugated Paper.....	1431
Disc Holder.....	922-925, 927, 935-936, 938
Furniture.....	1454
Hand.....	621, 1131
Knee.....	639-640, 1133
Kneeling.....	639
Message.....	1579
Scouring.....	292, 302, 320, 362
Soldering & Welding.....	1118
Spill Control.....	673-678, 680
Stripping.....	362
Surface Conditioning.....	302, 933
Pail Dollies	244
Pail Funnels	699
Pail Heaters	237
Pail Inserts	235
Pail Mixers	249
Pail Openers	250
Pail Tipplers	245
Pail Tumblers	248
Pails	27, 695-696
Pain Relievers	752
Paint	
Acrylic.....	1040, 1042-1044
Alkyd.....	1040-1041, 1043-1044
Antislip.....	1045
Applicator.....	1040
Epoxy.....	1042-1043
Floor.....	1019, 1044-1045
High Heat.....	1042-1043
Latex.....	1042
Line Striping.....	1039
Marking.....	1038, 1040
Rubber.....	1012, 1015, 1045
Paint Accessories	1046, 1050, 1054
Paint Brushes	1046-1049
Paint Markers	1142, 1442-1444
Paint Remover	1039
Paint Roller Covers	1049-1051
Paint Rollers	1049-1051
Paint Stencils	797-798
Paint Sticks	1142, 1443-1444
Paint Supplies	
Accessories.....	1046, 1050, 1054
Brushes.....	1046-1049
Cloths.....	1054
Drop Sheets.....	1054
Foam Rollers.....	1049
Paint Remover.....	1039
Paint Thinner.....	1037
Roller Covers.....	1049-1051
Rollers.....	1049-1051
Sponging & Ragging.....	1050
Wall Barriers.....	1054
Paint Thinner	1037
Painting Supplies	
Extension Poles.....	287-288, 292-294, 297-299, 302, 1048
Masking Tape.....	1050
Mixers.....	1046
Paint Guns.....	1051
Paint Sprayers.....	1042, 1051
Paint Trays.....	1050
Pallet Covers	1423
Pallet Lifters	181, 184, 201
Pallet Pullers	186
Pallet Racks	49-51
Pallet Servers	239
Pallet Tilters	184
Pallet Top Sheet	1423
Pallet Trucks	144, 182-186

Pallets		Eyewear.....	386-408, 412,	Structural Foam Deck.....	157	Power Sockets	1323, 1327
Aluminum.....	48	689-697, 1120, 1310-1311	Wood Deck.....	153-154	Power Strips, GFCI	1540-1542
Plastic.....	46-48, 1423	Faceshields	410-413, 557	Platforms		Power Tools	
Spill Control.....	704-708, 710, 713-714	Fingercots	600	Maintenance.....	141	Balancers.....	203
Palm Sanders	1180	Footwear	289, 527, 534, 631-638, 889	Work.....	135-136, 906	Combo Kits.....	1164-1166
Panel Trucks	158-160	Forearm Protectors	528-529, 534, 643	Pliers		Demolition Hammers.....	1187
Panels, Bins	7	Gloves	549, 558-559, 562-629, 644, 656,	Bolt Holder.....	1349	Dremel Tools.....	1192
Pans, Drip	252, 680-681	729-735, 762, 1129-1131, 1310-1311	Chain Nose.....	1348	Drill / Drivers...1156-1158, 1161, 1164, 1182	
Pants		Headwear	414-418, 526-527	Combination Slip-Joint.....	1377	Drill Chucks.....	1268-1269
Arc Flash.....	554	Hearing Bands	430-431	Convertible.....	1353	Drills.....	1158-1159, 1182-1187
Flame Resistant.....	554	Knee Pads	639-640, 1133	Crimping Die.....	1349, 1377	Grinders.....	916-917, 1163, 1168-1172, 1270
General Protection.....	534	Mitts	622	Cutting.....	1309-1312,	Hammer Drill / Drivers.....	1157-1159
Rain.....	541, 551-552	Respirators	447-466, 469-473, 475, 477,	1348-1351, 1353, 1377, 1383	Heat Guns.....	1190-1191
Work.....	550, 552	Shin Guards.....	479-481, 1122, 1127	Lineman's.....	1309-1312, 1348	Impact Wrenches.....	1159-1160, 1181
Paper		Petroleum Jelly	638	Locking.....	1288, 1309-1312,	Knockout.....	1162
Corrugated.....	1430	pH Meters	749	1351-1352, 1354	Nail Guns.....	1163, 1446
Kraft.....	1428, 1430	Pharmaceutical Products	1490	Long Nose.....	1309-1312, 1348, 1351, 1377	Nibblers.....	1173
Printer & Photocopier.....	1579	Cream Dispensers.....	331	MIG.....	1088	Power Scrapers.....	1186
Tissue.....	1428	Hand Creams.....	331, 333	Needle Nose.....	1349, 1351	Rotary Hammers.....	1159, 1185-1187
Toilet.....	340, 345-346	Hand Sanitizers.....	323-324, 333, 760	Non-Sparking.....	1383, 1386	Sanders.....	1180
Paper Bags	1435	Insect Repellent.....	335, 384	Pump.....	1377	Saws.....	872, 914, 1162-1163, 1174-1179
Paper Clamps, Hanging	1565	Insect Sting Relief.....	749	Retaining Ring.....	1353	Screw Guns	
Paper Clips	1580	Medicine.....	752	Round Nose.....	364	Screwdrivers.....	1161, 1187
Paper Cutters	1427, 1432-1433	Petroleum Jelly.....	749	Sets.....	1354	Shears.....	1173
Paper Towel Dispensers	340-343, 1583	Skin Conditioners.....	333	Slip Joint.....	1309-1312, 1348-1349	Power-Lock Discs	924-925, 935
Paper Towels	341-344, 346	Skin Creams.....	333	Snipe Nose.....	1377	PPE Battery Kit, Forklift	186
PAPR Respirators		Sunscreens.....	335, 384	Tongue & Groove.....1309-1312, 1348-1349		Precision Screwdrivers	1341
.....	466, 470-481, 1122, 1127	Phase Rotation Testers	1468	Vise Grips.....	1352	Prentice Drill Bits	969-970
Parade / Waiter's Gloves	625	Phillips® Bits	1345	Wire Stripping.....	1377	Presses, Arbor	208
Parallel Clamps	1286-1287	Phillips® Screwdrivers	1309-1312,	Plugs		Pressure Gauges	
Park Benches	380	1338-1341, 1378, 1383, 1386	Electrical.....	1084	Dial.....	1058
Parkas	552, 555	Photocopier Paper	1579	GFCI.....	1540	Dry.....	1489
Parking Curbs, Traffic Control	861	Picks	368, 1381	Plumb Bobs	1279, 1283	Liquid Filled.....	1489
Parking Signs	810, 820	Picks & Hooks	1307	Plumbers' Putty	1022	Tire.....	1224
Particulate	685	Pick-up Magnets	1297-1298	Plunger Cans	670	Pressure Sensitive Letters	800
Partitions		Picnic Tables	380	Plungers, Toilet	349	Pressure Sensitive Numbers	800
Column Protectors.....	86	Pictograms		Pneumatic Fitting Lockouts	1250	Pressure Washers	374-375
Enclosures.....	866	Right-To-Know.....	846	Pneumatic Pipe Fittings		Prick Punches	1370
Fences.....	865	WHMIS.....	845-846	1228, 1240-1244, 1247	Primers, Adhesive	1032
Gates.....	82-84, 216, 309, 866-867, 878	Pillows, Spill Control	680	Pneumatic Piping	81	Print Holders	1298
Guard Rails.....	54, 84-85, 489	Pin Face Spanners	1330	Pneumatic Tube Fittings	1239, 1248	Printer Paper	1579
Manhole Shields.....	489, 491	Pin Punches	1309-1310, 1312, 1368-1370	Pneumatic Tubing	1239	Privacy Shower Curtain	727
Perimeter Guards.....	51, 84-85, 88	Pinch Bars	1367, 1380	Pocket Gauges	1275	Probes	
Steel Mesh.....	51, 84-85, 88-89	Pins, Push	1569	Pocket Knives	1355	Temperature.....	1471, 1475, 1488
Strip Curtain Doors.....	91-93	Pipe Cements	1022	Pocket Levels	1115	Test.....	1463
Parts Cleaning		Pipe Contour Markers	1116-1117	Points, Cutting	1194	Process Gauges	1489
Bench Cans.....	992	Pipe Fittings		Poly Bags	1436	Propane Hoses, Welding	1068
Brushes.....	993	Kee Klamp®.....	79-81	Poly Tubing	1430, 1437	Propane Torches	1064
Dip Tanks.....	992	Lubrication.....	999-1001	Polyethylene Foam Tape	1416	Protective Wear Signs	806, 809
Dipping Baskets.....	992	Pneumatic.....	1228, 1240-1244, 1247	Pools, Spill Control	694, 711	Provioline® Solution	748
Parts Washers.....	993, 995	Pipe Flange Aligners	1115-1116	Porosity Detectors	1478	Pruners, Tree	369
Rinse Tanks.....	992	Pipe Markers	833-841	Portable Belts	928	Pry Bars	
Wash Tanks.....	992	Pipe Taps	960, 973	Portable Blasters ,		Crate Openers.....	1380, 1386
Parts Storage Carts	42	Pipe Tools		Sandblasting.....	1055, 1057	Multi-Purpose.....	1309-1312, 1366
Parts Washers	993, 995	Clamps.....	1285	Portable Blowers	359, 488, 1059-1060	Nail Pullers.....	1366, 1380
Cleaning Fluids.....	995	Contour Markers.....	1116-1117	Portable Buildings ,		Non-Sparking.....	1380
Patches, Eye	728, 730, 735	Flange Aligners.....	1115-1116	Smoking Shelters.....	381	Rolling Head.....	1367
Pavement Tape	868	Flaring Tools.....	1374	Portable File Belts	928	Tack Pullers.....	1340
Pedestal Fans	1497-1499	Jacks.....	1115	Portable Heaters	1504	with Handle.....	1367
Pencil Grinders, Air	1223	Wrenches.....	1309, 1372-1373, 1378	Portable Scales	1492-1494	Pry Dollies	177
Pencil Sharpeners	1578	Pipe Trucks	160-161	Portable Sheds	381	Psychrometers	1475
Pencils	729, 732-733, 1578	Pipefitting Levels	1115-1117	Posidriv® Bits	1345	PTC Fittings	1239
Grease.....	1142, 1445	Piping		Positioners, Work	181	Pullers	
Penetrants		Kee Klamp®.....	81	Positioning and Restraint Lanyards	508	Pallet.....	186
5-Way.....	1013	Pneumatic.....	81	Positive Pressure Respirators	466, 470-481, 1122, 1127	Pilot Bearing.....	1365
Bolt Removal.....	1013	Placards, TDG	851-854	Postal Tubes	1434	Pump Lubricants	1144
KB 88.....	1013	Plasma Cutter Guides	1069	Posters		Pump Pliers	1377
Multi-Purpose.....	1013	Plasma Cutters	1090	SDS.....	847	Pump Wrenches	1335
Water Based.....	1144	Plastic Bandages	729-735, 741-742, 745	WHMIS.....	847	Pumps	
WD-40®.....	1004, 1012-1013	Plastic Strips	734, 742	Posts		Air Operated.....	258
Penlights	1512	Plates		Crowd Control.....	821, 874-880	Cam & Groove Fittings.....	263
Pennants, Traffic Control	871	Cafeteria.....	1583	Snow Clearing.....	871	Coolant Tanks.....	1150
Pens		Styrofoam.....	1583	Pot Brushes	26, 301	Diaphragm.....	258
Office.....	1578	Platform Ladders	127, 129-131, 135	Pouch Tape	1449	Discharge Hoses.....	263
pH.....	1490	Platform Scales	1494-1495	Pouches		Drum.....	254-258
Perimeter Guards	51, 84-85, 88	Platform Trucks		Bubble.....	1435	Engine-Powered.....	264
Permanent Markers	1442, 1445, 1578	Aluminum Deck.....	155-156	Tool.....	523, 1387-1388, 1390-1392	Grease.....	999-1000
Personal Protection		Dead Skids.....	154	Powder, Scouring	316	Hand.....	254-256, 258-259
Dust Masks.....	447, 453	Non-skid Vinyl Deck.....	156	Power Bars	1541	Lever.....	256
Ear Muffs.....	433-439, 549	Plastic Deck.....	156-158	Power Cable Adapters, TIG Torch	1109	Lockouts.....	259
Ear Plugs.....	423-429, 431	Semi-Live Skids.....	154, 158	Power Cables, TIG Torch	1110	Machine Tool.....	1150
Elbow Protectors.....	643	Steel Deck.....	152-153, 155, 160, 165	Power Scrapers	1186	Rotary.....	256-258

INDEX

Submersible.....262-263, 1150
Transfer.....258, 263, 671

Punches
Aligning.....1369
Center.....1309-1310, 1312, 1368, 1370
Drift.....1309-1310, 1369-1370
Drive Pin.....1369
Pin.....1309-1310, 1312, 1368-1370
Prick.....1370
Starting.....1370

Purifiers, Air.....1500

Push Brooms.....287-290, 301

Push Pins.....1569

Push to Connect Fittings.....1239

Putty Knives.....1052
Flexible.....1052, 1382
Stiff.....1052, 1382, 1386

-Q-

Quick Clamps.....1288

Quick Couplers.....1207, 1233, 1246, 1248-1250

Quick-Connects, Welding.....1074

-R-

Rack, Carton.....1434

Racks
Bar.....53
Bicycle.....379
Bin.....8-9, 11, 39, 121
Broom & Mop.....286
Cantilever.....52
Coat.....1581
Drum.....245, 703
Gas Cylinder.....1079
Key.....1570
Pallet.....49-51
Reel.....78
Sheet.....53
Stacking.....41, 53-54, 157
Threaded Rod.....45
Tire.....78
Welding.....1078

Radiant Heaters.....1503-1505

Radiator Heaters.....1503

Radios, Two-Way.....435, 438-439, 441-442

Rafter Squares.....1280

Rag Rugs, Spill Control.....679

Rags.....338, 1054

Rail, Grab.....350

Rail Chocks.....210

Rainwear
Flame Resistant.....541-542, 548
Hoods.....541-543, 548
Jackets.....541-542, 551
Overalls.....542
Pants.....541, 551-552
Suits.....540, 543

Rakes.....367

Ramps
Twin.....214
Walk.....214

Rare Earth Magnets.....1299

Rasps
Half Round.....1305
Round.....1305

Ratchet Counters.....1483

Ratchet Straps.....1456

Ratchet Wrenches, Air.....1206, 1210

Ratcheting Wrenches.....1333-1334

Ratchets
1 1/2" Drive.....1324
1" Drive.....1324
1/2" Drive.....1315, 1317-1318, 1320-1321
1/4" Drive.....1317, 1324
3/4" Drive.....1322
3/8" Drive.....1316, 1318-1319

Razor Blades.....1052

Reamers
Adjustable.....985
Chucking.....981-985
Hand.....981
Nozzle.....1088
Taper Pin.....982

Rebar Cutters.....1361

Rebar Tie Wire Cutters.....1350

Receiving Scales.....1494

Receptacles
Electrical.....1084
Sanitary Napkin.....348-349

Reciprocating Saw Blades.....1201

Reciprocating Saws
Air.....1214
Cordless.....1163
Electric.....1179

Record Storage, Shelving.....57

Recycling Containers.....276-279, 1577

Reel Dispensers.....167

Reel Racks.....78

Reels
Cord.....1531-1532, 1537
Hose.....1076, 1234-1237, 1532
Welding.....1076

Refacers, Welding Tip.....1073

Reflectors, Traffic Control.....859

Refractometers.....1490

Refrigerators.....1584

Regulator, Calibration Gas.....484-486

Regulator/Flowmeters, Welding.....1068

Regulators
In-Line.....1232, 1256, 1261
Welding.....1064, 1066-1069

Rehydration Drinks, Sqwincher®.....648-649

Repair Kits, Hose.....377

Repellent, Insect.....335, 384

Rescue Hoist.....492

Rescue Systems.....490-492, 496, 518

Resin Fibre Discs.....922-923, 925

Respirators
Ambient Air Pump.....466, 481, 1127
Cartridges.....456, 460-464, 466, 470, 472-473, 475, 477, 480
Disposable.....447-453
Emergency Escape.....459
Filters.....452, 456-459, 461, 464, 475, 480
Fit Test Kits.....465
Full Face.....455, 458-459, 462-463, 469
Half Mask.....454-455, 458, 461-464, 469
Headgear.....473, 479, 1127
PAPR.....466, 470-481, 1122, 1127
Positive Pressure.....466, 470-481, 1122, 1127
SCBA.....469
Supplied Air.....466, 479
Welding.....450

Retaining Compounds.....1027

Retaining Ring Pliers.....1353

Retaining Rings, MIG Gun.....1095

Revolving Bins.....29

Right-To-Know Pictograms.....846

Rings, Key.....794

Rinse Tanks.....992

Risers, Dock.....215

Robertson® Screwdrivers.....1309-1312, 1338-1340

Rockers, Drum.....245

Rod / Electrode Containers.....1089, 1134

Rods, TIG.....1136-1138, 1140

Rollers
Fountain.....799
Hand.....799
Machinery.....204-205

Rolling Head Bars.....1367

Rolling Knee Dollies.....209

Rolling Ladders.....135, 137-140

Rolling Workbenches.....125

Rolls
Cartridge.....929
Spill Control.....673-678, 689-690
Surface Conditioning.....930, 933-934

Roofing Knives.....1441

Rope
Crowd Control.....879
Packaging.....1450

Rope Ends, Crowd Control.....879

Rope Grabs.....517-518, 520

Rotary Cutters.....1163

Rotary Hammer Bits.....1195-1196

Rotary Hammers.....1159, 1185-1187

Rotary Pumps.....256-258

Rotary Sanders, Air.....1211

Rotators, Drum.....239, 248

Round Files.....1302, 1304

Round Nose Pliers.....364

Round Point Shovels.....366, 1381

Round Rasps.....1305

Rubber Bands.....1423, 1580

Rubber Coating.....1012, 1015, 1045

Rubber Cutting Knives.....1371, 1441

Rubber Paint.....1012, 1015, 1045

Rubbing Alcohol.....748

Runner Matting
Carpet.....886-887
Needle Rib.....885
Pile.....885-888
Polypropylene.....885
Rubber.....888, 901, 909
Vinyl.....901

Rust Converters.....1014, 1146, 1148

Rust Preventers.....1014, 1146

Rust Removers.....1014, 1146

-S-

Safes.....1562, 1577

Safety
Anti-Skid Cleats.....872
Arm Protection.....528-529, 534, 643
Cans.....668-669
Cones.....48, 308, 1423
Cooling Clothing.....645-647
Crowd Control.....794, 821, 874-880
Ear Protection.....423-431, 433-439, 549
Ergonomic Products.....639-644, 746, 1133
Eyewear.....386-408, 412, 689-697, 1120, 1310-1311
Faceshields.....410-413, 557
Fall Protection.....141, 490-492, 494-502, 507-510, 512-520, 522-524, 560
Fire Protection.....651-656, 753
First Aid.....335, 384, 716-763
Flame Resistant Clothing.....541-542, 548
Floor Signs.....296, 308
Flooring.....872-873, 906
Foot Protection.....289, 527, 534, 631-638, 889
Gas Detectors.....482, 484-486
Hand Protection.....549, 558-559, 562-629, 644, 656, 729-735, 762, 1129-1131, 1310-1311
Headwear.....414-418, 526-527
High Visibility Clothing.....543, 545-549, 551
Hygienic Products.....325, 329, 348-349, 731, 734, 751, 758
Insect Repellent.....335, 384
Locking Systems.....654, 770, 782, 1562, 1570, 1577
Lockouts.....106, 259, 764, 768-769, 772-784, 786-790, 1250
Matting.....560, 727, 891-894, 896-897, 899-900, 902-909, 1119
Medicine.....752
Mirrors.....881-883
Oxygen Masks.....763
Padlocks.....99, 110, 764-773
Pharmaceutical.....323-324, 331, 333, 335, 384, 749, 760
Rehydration Drinks.....648-649
Respirators.....447-466, 469-473, 475, 477, 479-481, 1122, 1127
Safes.....1562, 1577
Security Seals.....794, 1451

Shin Guards.....244, 252, 266, 290, 638
Spill Control.....244, 252, 266, 290, 670, 673-687, 689-714, 760
Traffic Clothing.....543, 545-549, 551
Traffic Control.....83, 309, 545-548, 850, 858-864, 867-869, 871, 874
Whips.....856

Safety Pins.....730-735, 751

Safety Signs.....727, 806, 809, 849

Safety Tags.....786-788, 790

Salt.....364

Salt & Sand Containers.....363, 689

Salvage Drums.....689-690, 693, 697, 700-702, 713

Sandblasting Equipment
Dust Collectors.....1056
Guns.....1057, 1225
Media.....1055
Media Recyclers.....1055-1056
Portable Blasters.....1055, 1057
Suction Cabinets.....1056-1057

Sandblasting Gloves.....591

Sanders
Belt.....1180
Belt - Air.....1213, 1216-1217, 1220-1221
Hand.....1053
Orbital - Air.....1207, 1211-1212, 1218-1219
Palm.....1180
Rotary - Air.....1211

Sanding Blocks.....1053

Sanding Sponges.....933

Sandpaper.....930-932

Sanitary Napkin Dispensers.....348

Sanitary Napkin Receptacles.....348-349

Sanitary Napkins.....348

Sanitizing Solution
First Aid Instruments.....751

Saw Blades
Circular Saw.....914, 1202-1203
Combination Saw.....1203
Cut-Off.....1203
Mitre Saw.....1203
Reciprocating Saw.....1201

Sawhorses.....135

Saws
Bandsaws.....1178
Chop.....914, 1174
Circular.....872, 1162, 1177
Drywall.....1053
Framing.....872
Hacksaws.....1300-1301, 1309-1312
Hole.....1197-1198
Jig Saws.....1178
Mitre.....1175-1176
Reciprocating.....1163, 1179
Reciprocating - Air.....1214

Scaffolding.....134, 141-143

Scales, Air.....1207, 1214

Scales
Bench.....1433, 1491-1495
Counting.....1491
Crane.....203, 1496
Dial.....1494
Floor.....1496
Hanging.....203, 1493-1494, 1496
Platform.....1494-1495
Portable.....1492-1494
Receiving.....1494
Utility.....1492-1494
Weighing.....1491-1492

Scaling Chisels.....1088, 1194

Scaling Hammers.....1364

SCBA Respirators.....469

Scissors
Electrician.....1357
First Aid.....729-735, 747
General Purpose.....1356
Industrial.....1356-1357, 1442, 1580

Scoop Shovels.....1381

Scoops
Aluminum.....366, 994
Grain and Coal.....366
Litter.....282, 290, 383

Polyethylene.....	363	Seating	Packing List Envelopes.....	1449	Kevlar®.....	529
Polypropylene.....	694	Chair Caddies.....	Pallets.....	46-48, 1423	Nylon.....	528
Spill Control.....	687	Ergonomic.....	Strapping.....	1419-1422	Polypropylene.....	528, 534
Scoreboard Signs	822-823	Folding Chairs.....	Tamper Seals.....	1451	PVC.....	528-529
Scotch® Tape Dispensers	1580	Footrests.....	TDG Labels.....	855, 1448	SuperFabric®.....	529
Scotch-Brite™ Deburring Wheels		Locker Room Benches.....	Temperature Labels.....	1429	Vinyl.....	528
.....	936, 938, 1271	Office Chairs... 1546, 1548-1549, 1553-1554	Shipping & Receiving Signs	813	Welding.....	1132
Scotch-Brite™ Discs	935	Stacking Chairs.....	Shirts		Sleigh Shovels	365
Scouring Pads	292, 302, 320, 362	Swivel Stools.....	Arc Flash.....	554	Slide Hammers	1365
Scouring Powder	316	Task.....	Flame Resistant.....	554	Slings	
Scrapers		Security	General Protection.....	534	Chain.....	189
Drywall.....	1052, 1382	Carts.....	Work.....	550	Drum Lifting.....	243
Floor.....	292, 298	Gates.....	Shock Absorbing Lanyards	141, 507-510	Nylon.....	188
Non-Sparking.....	1382, 1386	Locking Systems.....	Shoe Brushes	291, 889	Polyester.....	188-189
Power.....	1186	Shoe Covers	289, 527, 889	Slip Hooks	192-193
Rubber.....	886-888	Shop Carts	7-8, 42, 73, 76-77, 161-170	Slip Joint Pliers	1309-1312, 1348-1349
Sidewalk.....	368	Lockouts.....	Shop Coats	550	Slot Drills	986-987
Spill Control.....	687	Shop Cranes	202, 208	Slot Screwdrivers	1309-1312, 1338-1341, 1378, 1383, 1386
Scratch AWL Screwdrivers	1340	Safes.....	Shop Desks	102, 126	Slotted Bits	1344-1345
Scratch Brushes	946-947, 1087	Seals.....	Shop Lifters	180, 703	Slow Moving Vehicle Signs	859
Screens		Self-Adhesive Letters	Shop Stands	207, 209	Small Parts Bins	25, 31, 39
Urinal.....	349	Self-Adhesive Numbers	Shop Sweepers	286, 358	Fiberboard.....	11
Welding.....	1118-1119	Self-Retracting Lanyards	Shop Tables	102	Small Parts Cabinets	30-34, 37-38, 42-43, 45
Screw Extractors	960, 989	Shoring Beams	212, 1457	Small Parts Cases	
Screw Guns	1187	Self-Retracting Life Lines	Shovels		Smoke Alarm Testers	656
Screwdriver Bits		Round Point.....	366, 1381	Smoke Alarms, Ionization	655
Bit Holders.....	1343	Self-Stick Bandages	Scoop.....	1381	Smoke Ejectors	1501
Cross-Point / Phillips®.....	1345	Sleigh.....	365	Smoking Shelters	381
Hex.....	1344	Semi-Live Skids	Snow.....	364-365	Snipe Nose Pliers	1377
Hex Square Drives.....	1340, 1343	Sensor, Gas Detectors.....	Spill Control.....	686	Snips	
Nutsetters.....	1343	Service Benches	Square Point.....	365-366, 368, 1381	All Purpose.....	1357-1359
Posidriv®.....	1345	Shower Testers	726	Duckbill.....	1357
Slotted.....	1344-1345	Service Writers	Showers, Emergency	718-719	Grape & Orchid.....	1357
Square Recess.....	1344-1345	Shredders, Paper	1580	Metal Cutting.....	1358-1359
Torque.....	1343	Sets	Shrink Wrap	1426	Snow Brushes	364
Torx®.....	1343-1344	Cold Chisel.....	Shrink Wrap Machines	1426	Snow Clearing Posts	871
Tri-Wing.....	1344	Side Cutting Pliers	1349, 1351, 1377	Snow Fences	865
Screwdrivers		Files.....	Sidewalk Scrapers	368	Snow Flags	871
Air.....	1207, 1209, 1211, 1222	Forstner Bit.....	Signal Horns	444	Snow Shovels	364-365
Cabinet Tip.....	1309-1312, 1338-1340, 1383	Nut Driver.....	Signs		Soap	
Cordless.....	1161, 1187	Pliers.....	Admittance.....	803-810, 813	Antibacterial.....	324-325, 329
Cross-Point / Phillips®.....	1309-1312, 1338-1341, 1378, 1383, 1386	Rotary Hammer Bit.....	Aisle.....	12, 48	Antimicrobial.....	326
.....		Screwdriver.....	Chemical Hazard.....	804, 808	Body Lotion.....	749
Flat Tip / Slot.....	1309-1312, 1338-1341, 1378, 1383, 1386	Socket.....	Confined Space.....	758, 804, 808	Hair and Body.....	325, 329
Multi-Tip.....	1340-1341	Tap & Drill.....	CSA Standard.....	814-817	Hand.....	315, 324-329, 331-332
Precision.....	1341	Wrench... 1309-1310, 1312, 1332-1334, 1337	Direction and Exit.....	807, 810-811	Soap Dispensers	315, 324-326, 330-333
Scratch AWL.....	1340	Shampoo	Ear Protection.....	806, 809	Soapstone	1143
Sets.....	1338-1341, 1383	Electrical Hazard.....	804-805, 808	Socket Accessories	1314-1324, 1327
Square / Robertson®.....	1309-1312, 1338-1340	Shards Collectors	Exit.....	1521	Socket Sets	
Torque.....	1329	Eye Protection.....	806, 809	Hex Bit.....	1315
Torx®.....	1339, 1341	Shears	Fall Protection.....	806	Impact.....	1325-1326
Scribe Pens	1212, 1223	Air.....	Fire.....	653, 807, 810, 812, 817, 822	Standard.....	1309-1310, 1312-1315
Scrub Brushes	26, 291, 300, 946	Fabric.....	First Aid.....	727, 805, 809, 812	Sockets	
Scrubbers, Hand	292, 302, 320	Hedge.....	Floor.....	296, 308, 813	Hex Bit.....	1316
SDS		Industrial.....	Hazardous Materials.....	808	Impact.....	1323-1324, 1327
Binders.....	849	Lopping.....	Machinery & Operations.....	804-805, 809	Non-Sparking.....	1385
Information Centre.....	848-849	Power.....	Maintenance.....	808-809, 813	Power.....	1323, 1327
Poster.....	847	Sheathing Tape	No Smoking.....	806-808, 810	Standard.....	1314-1322
Sealant, Spill Control	683, 694	Parking.....	810, 820	Socks, Spill Control	680
Sealant Tape	1027-1028, 1416	Sheet Holders	Protective Wear.....	806, 809	Soft Face Hammers	1363
Sealants		Sheet Protectors	Safety.....	727, 806, 809, 849	Solder	1140
Flange.....	1026	Sheets, Burn Care	Scoreboard.....	822-823	Soldering Guns	1080-1082
Foam.....	1023	Shelf Bins	Shipping & Receiving.....	813	Soldering Irons	1080-1082
Gaskets.....	1025-1026	Slow Moving Vehicle.....	859	Soldering Pads	1118
Retaining Compounds.....	1027	Bin.....	TDG.....	851-854	Soldering Stations	1082
Silicone.....	1025	Chrome.....	Traffic.....	210, 807, 810, 812, 820-821, 851, 857-859	Soldering Tips	1064
Teflon® Tape.....	1027-1028, 1416	Plastic.....	Washroom.....	813	Solutions, Lens Cleaning	409
Thread.....	1026	Stainless Steel.....	Silicone Lubricants	1008, 1010	Solvent Free Degreasers	313, 1002-1003
Threadlockers.....	1020, 1027-1028	Steel.....	Silver & Deming Drill Bits	954	Sorbents	
Sealers, Floor	1019	Steel Wire.....	Single Ladders	127, 132-133	Absorbents.....	684-685, 691-692
Sealing Press, Security Seals	794	Widespan.....	Single-Gas Detectors	482, 485	Booms.....	679
Sealing Spatula	1052	Shields	Skid Lifts	181	Pads.....	673-678, 680
Seals		CPR.....	Skin Conditioners	333	Particulate.....	685
Sealing Press.....	794	Face.....	Skin Creams	333	Pillows.....	680
Security.....	794, 1451	Manhole.....	Sky Hooks	199	Rag Rugs.....	679
Steel.....	1419, 1421	Shims	Sledge Hammers		Rolls.....	673-678, 689-690
Tamper.....	1451	Double Faced.....	369, 1366	Socks.....	680
Seamers, HVAC	1359	Shin Guards, Plastic	Non-Sparking.....	369, 1365, 1380	Sweeping Compounds.....	290
Seat Cover, Automotive	280, 546	Shipping	Sleeves		Sorters, Mail	1566
		Benches.....	Canvas.....	528		
		Cargo Nets.....	Cotton.....	528-529		
		Handling Labels.....				
		Jack Bars.....				
		Logistic Tracks.....				
		Mailers.....				
		Moving Blankets.....				

INDEX

Sound Level Meters		Stainless Steel Cleaners316, 319, 1004	Revolving Bins.....29	Surface Conditioning Belts937
Digital.....440, 1480		Stairway Ladders140	Safety Cans.....668-669	Surface Conditioning Discs934-936, 938
Integral Probe.....440, 1480-1481		Stamps, Hand795-796, 1117	Salt & Sand Containers.....363, 689	Surface Conditioning Pads302, 933
Spade Handle Drills1183-1184		Stands	Shelf Bins.....13-15, 25	Surface Conditioning Rolls930, 933-934
Spades		Automotive.....207, 209	Shelving Units.....11, 17, 55-58, 61-67,	Surface Mount Thermometers1473
Drain.....366		Engine.....208	70-75, 78, 99	Surge Protectors1540-1541
Garden.....366		Equipment.....170	Small Parts Bins.....11, 25, 31, 39	Surge Suppressors1540, 1542
Spading Forks367		Garbage Bag.....383	Small Parts Cabinets.....30-34, 37-38, 42-43, 45	Surgical Tape729, 744
Spanner Wrenches1330		Gas Cylinder.....1079	Small Parts Cases.....36	Suspenders1389
Spanners, Pin Face1330		Monitor.....1577	Stacking Bins.....4-6, 13-17, 21, 26, 40-41	Sweatbands420, 1133
Spats, Welding1132		Work.....209, 225	Stacking Racks.....41, 53-54, 157	Sweeper Magnets286
Spatula, Sealing1052		Staple Removers, Packaging1447	Static Bags.....1435	Sweepers286, 358
Spatulas, Non-Sparking1382		Staplers, Packaging1446-1447	Steel Bins.....40-41, 44-45	Sweeping Compounds290
Speed Bumps, Traffic Control860		Staples	Tanks.....27	Switch Brooms290
Spill Control		Carton Staplers.....1446-1447	Threaded Rod Racks.....45	Swivel Connectors1219, 1250
Berms.....681, 711-712, 714		Office Staplers.....1446	Tire Racks.....78	Swivel Stools1554
Brooms.....687		Pneumatic Stapler.....1447	Tool Aprons.....1391	Synthetic Greases1018
Containers.....709-710		Starcarts™.....174-175	Tool Bags.....1391-1393, 1464	
Drain Protectors.....682		Starting Punches1370	Tool Belts.....1389	
Drain Seals.....681-683, 689-693		Static Bags1435	Tool Boxes.....1309-1311, 1393-1394	
Drip Cans.....670		Stations	Tool Cabinets.....103, 1309, 1312, 1395-1400	
Drip Pans.....252, 680-681		Docking.....482-483, 485-486	Tool Carts.....123-125, 1395, 1397, 1400	
Drum Carts.....701		Lens Cleaning.....409	Tool Chests.....1309-1310, 1394-1399, 1402-1403	
Drum Dollies.....244, 266, 701-702		Stem Thermometers1473	Tool Holders.....1387-1388, 1392	
Drum Racks.....703		Stencil Inks799	Tool Pouches.....523, 1387-1388, 1390-1392	
Drum trays.....681, 703, 711, 713		Stencils	Transfer Boxes.....19	
Funnels.....699		Paint.....798	Van and Truck Equipment.....1407	
Kits.....689-698, 760		Paint & Ink.....797	Straight Blade Knives1382, 1386	
Leak Diverters.....683		Step Cans269-270, 761	Straight Ladders127, 132-133	
Leak Seal.....683		Step Ladder Hand Truck1581	Straight Line Clamps1290, 1292	
Neutralizers.....686, 697		Stepladders127-128, 134-135	Straight Wrenches1373	
Overpack.....689-690, 693, 697, 700-702, 713		Stepstands, Steel135-137	Strainers, Drum & Pail235	
Pallets.....704-708, 710, 713-714		Stepstools	Strap Wrenches1372	
Pools.....694, 711		Fiberglass.....134	Strapping	
Salvage Drums.....689-690, 693, 697,		Polyethylene.....136, 1549	Buckles.....1420-1422	
700-702, 713		Stethoscopes756	Dispensers.....1420, 1422	
Scoops.....687		Stick Electrodes1136-1137, 1139	Machines & Tools.....1419-1422	
Scrapers.....687		Stick-On Discs926-927	Poly.....1421-1422	
Sealant.....683, 694		Sting Relief, Insect749	Seals.....1419, 1421	
Shelters.....708		Stirring Sticks1583	Stainless Steel.....1420	
Shovels.....686		Stock1274	Steel.....1419-1420	
Sorbents.....290, 673-680, 684-685, 689-692		Stock Picking Carts165	Tape.....1412	
Spinal Backboard755		Stock Trucks166	Straps, Moving150, 246, 1454-1456	
Spiral Bands929		Stools	Straws1583	
Spilts731, 734, 754		Swivel.....1554	Stretch Wrap	
Finger.....754		Task.....209, 1134, 1550-1554	Banding Film.....1425	
Leg.....731, 734, 754		Stop & Go Lights220	Blown.....1424	
Sponges, Sanding933		Stop Sleeves194	Cast.....1424, 1426	
Spoons, Cafeteria1583		Stopwatches645, 1475, 1483	Clear.....1424-1425	
Spot Lights187, 1516, 1518		Storage	Coloured.....1424	
Spotter, Drum247		Bar Racks.....53	Machine.....1426	
Spray Adhesives1036, 1418		Bin Racks.....8-9, 11, 39, 121	Opaque.....1424	
Spray Bandages742		Bin Shelves.....6, 11, 15-17, 21, 59-60	Stretch Wrap Dispensers1424-1426	
Spray Lubricants1008-1013, 1018, 1543		Bottles.....28	Stretchers	
Sprayers		Cabinet Tables.....124	Folding.....754	
Lawn & Garden.....320, 371-373		Cabinets.....9-10, 35, 94-103, 381,	Wire Basket.....755	
Paint.....1042, 1051		658, 660-667, 1561, 1563	Striking Face Wrenches1331	
Trigger.....302, 320		Cantilever Racks.....52	String Lights1528	
Spreaders, Adhesive1053		Carton Rack.....1434	Strip Curtain Doors91-93	
Spring Clamps1288		Collapsible Containers.....44-45	Strip Magnets1298	
Sprinklers, Garden Hose376		Dispenser Bottles.....672	Stripping Machines1039-1040	
Spud Wrenches1372		Distribution Containers.....18-20, 22-24, 1564	Strippers, Wire1351	
Square Files1304		Drawers.....37	Stripping Pads362	
Square Point Shovels365-366, 368, 1381		Equipment Cases.....1461, 1464-1465, 1471	Stroboscopes1483	
Square Recess Bits1344-1345		ESD Bins.....25	Structural Adhesives1032-1034	
Square Screwdrivers1309-1312, 1338-1340		Food Handling Containers.....175	Structural Wrenches1330	
Squares		Gas Cans.....671-672	Structures	
Bevels.....1280-1281		Gas Cylinder Brackets.....1079	Bollards.....54, 85, 87, 865	
Carpenter.....1280		Gas Cylinder Cabinets.....1077	Portable Buildings.....381	
Drywall.....1280		Gas Cylinder Racks.....1079	Portable Sheds.....381	
Rafter.....1280		Gas Cylinder Stands.....1079	Tents.....382, 489, 647	
Try.....1280		Horizontal Sheet Rack.....53	Submersible Pumps262-263, 1150	
Welding.....1086		Jars.....28	Suction Cabinets1056-1057	
Squeegees296-299, 301, 687		Jobsite Boxes.....36, 1394, 1401-1407	Suggestion Boxes1581	
Sqwincher®648-649		Lockers.....104-110	Suits, Rain540, 543	
Stackers		Mobile Bins.....6	Sunscreens335, 384	
Drum.....242		Nesting Bins.....18-19, 26	Supermills987	
Stacking Bins4-6, 13-17, 21, 26, 40-41		Oily Waste Cans.....670-671	Supplied Air Respirators466, 479	
Stacking Chairs1555		Pallet Racks.....49-51	Support Bandages731-732, 746	
Stacking Dollies20		Paper Bags.....1435		
Stacking Racks41, 53-54, 157		Plunger Cans.....670		
Stacking Tables1556-1557		Poly Containers.....27, 234, 671		



T Squares, Drywall1280
Table Caddies1557
Tables
Cabinet.....124
Changing.....348
Folding.....382, 1557
Lift.....178-179, 181, 184
Picnic.....380
Shop.....102
Stacking.....1556-1557
Work.....120, 1556, 1561
Tachometers1482
Tags
Accident Prevention.....786-788, 790
Blank.....791-793, 1448
Brass.....793
Caution.....790
Danger.....790
Key.....1570
Lockout.....786-790
Magnetic.....12
Numbered.....793
Safety.....786-788, 790
Tally Counters1483
Tamper Proof Torque Mark1342
Tamper Seals1451
Tampers348
Tanks
Coolant.....1150
Dip.....992
Rinse.....992
Storage.....27
Wash.....992
Tap & Drill Sets973
Tap Wrenches960, 977
Tape
Aisle Marking.....869-870
Aluminum Foil.....1020, 1415
Anti-Skid.....872-873
Bag Sealing.....1436
Barricade.....868
Box Sealing.....1410-1411, 1413, 1429
Conspicuity.....850
Double Sided.....1416
Duct.....1415
Electrical.....1417, 1544
Filament.....1412
First Aid.....729, 744
Flagging.....869
Glow in the Dark.....811, 870, 872-873
Gummed.....1413
Masking.....1414
Measuring.....1276-1279, 1309-1312
Office.....1580
Painter's Masking.....1050
Pavement.....868
Polyethylene Foam.....1416
Pouch.....1449
Sheathing.....1437
Strapping.....1412
Surgical.....729, 744

Teflon®.....1027-1028, 1416	TIG Torches1091, 1101, 1103-1105	Towels	Tube Fittings, Pneumatic1239, 1248
Vinyl.....829, 1416	TIG Welders1091, 1113	Cooling.....645-646	Tubes
Tape Dispensers	Tilt Trucks172-173	Hand.....334, 340-344, 384, 1005, 1583	Conductor.....1096
Aisle Marking Tape.....868	Tilters	Paper.....341-344, 346	Postal.....1434
Box Sealing Tape.....1411, 1429	Drum.....239-240, 254	Tracks, Logistic212, 1457	Tubing, Pneumatic1239
Filament Tape.....1411-1413	Engine.....208	Trades Carts169	Tubing Cutters1374
Gummed Tape.....1411, 1413	Tilting Vises1295-1296	Traffic Control	Tumblers, Pail248
Office.....1580	Time Clocks1575	Banners.....859	Tungsten Electrode Grinders1113-1114
Two-Way Tape.....1416	Timers	Barricade Tape.....868	Tungsten Electrodes1114
Taper Pin Reamers982	Digital.....1483	Barricades.....83, 309, 867, 874	Turf Edgers368
Tapping Compounds1149	Mechanical.....378	Channelizers.....864	Turntables, Pallet181
Taps	Tip Cleaners1073	Cones.....862-863	Turpentine1037
Hand.....956-960, 974-975, 977, 988	Tip Refacers1073	Delineators.....863-864	Tweezers, First Aid729-735, 751
Machine.....976	Tipppers, Pail245	Flagging Tape.....869	Twin Ramps214
Pipe.....960, 973	Tips	Flags.....858	Twine, Packaging1450
Tarpaulins379, 1453	Cutting.....1065, 1070-1072	Flares.....859	Two-Way Radios435, 438-439, 441-442
Task Chairs1546, 1551	Heating.....1072	Harnesses.....548	Two-Way Tape Dispensers1416
Task Lights1523, 1529-1530	Soldering & Brazing.....1064	Parking Curbs.....861	
Task Seating209, 1134, 1546, 1550-1554	Tire Bags280	Pennants.....871	
Task Stools209, 1134, 1550-1554	Tire Inflator Gauges1224	Reflectors.....548, 850, 859	
TDG Labels855, 1448	Tire Pressure Gauges1224	Speed Bumps.....860	
TDG Placards851-854	Tire Racks78	Vests.....545-546	
TDS Meters1490	Tissue Paper1428	Traffic Safety Clothing	
Technicians' Tools1309-1312, 1378-1379	Tissues, Lens Cleaning409	Hat/Toque.....549	Umbrellas, Welding1118
Tees, Pipe Thread1240-1241, 1244	Toe Guards637	Jackets.....547-548	Undershirts552
Teflon® Tape1027-1028, 1416	Toggle Clamps1290-1291	Overalls.....543	Undershirts552
Telescopic Lights1528	Toilet Augers1375	Pants.....548, 551	Uppers, Drum250
Temperature Crayons1142, 1445	Toilet Auto Flush Adapter350	Parkas.....547	Upright Protectors54, 85
Temperature Labels1429	Toilet Bowl Brushes349	Rain Jackets.....543	UPS Systems1542
Temperature Probes1471, 1475, 1488	Toilet Bowl Cleaners314	Rain Suits.....543	Urinal Blocks349
Temperature Recorders1476	Toilet Paper340, 345-346	Sweatshirts.....547	Urinal Screens349
Tennis Elbow Braces643	Toilet Paper Dispensers345-347	T-Shirts.....547	Utility Carts76, 166, 168-170
Tensabarriers821, 874-880	Toilet Plungers349	Vests.....545-547	Utility Knives1382, 1440-1442
Tent Heaters489	Toilet Seat Cover Dispensers348	Traffic Signs210, 807, 810, 812,	Utility Scales1492-1494
Tents, Work382, 489, 647	Toilet Seat Covers348	820-821, 851, 857-859	
Test Leads1463	Tongue & Groove Pliers	Traffic Wands1509	
Test Probes14631309-1312, 1348-1349	Traffic Cone Bars863	
Test Weights1496	Tongue Depressors734, 747	Trailer Jacks212	
Testers	Tool Balancers203	Trailer Winches195	
Circuit.....1461, 1539	Tool Holders	Transfer Boxes19	
Hardness.....1479	ER Collet Chucks.....1269	Transfer Pumps258, 263, 671	
Insulation.....1467	Turning Tools.....986	Transparent Bandages741	
Motor Rotation.....1468	Tool Kit, Welder's1134	Trash Cans169, 266-275, 349-350,	
Multi-Function.....1462	Tool Kits, Non-Sparking1386	383, 761, 1577	
Phase Rotation.....1468	Tool Lanyards522-524	Trays	
Shower.....726	Tool Storage	Boot.....889	
Smoke Alarm.....656	Aprons.....1391	Drum.....681, 703, 711, 713	
Voltage.....1462, 1543	Bags.....1391-1393, 1464	Filing.....1577	
Tethering, Hard Hats420, 522, 524	Belts.....1389	Paint.....1050	
Thermal Cameras1470	Boxes.....1309-1311, 1393-1394	Tree Pruners369	
Thermocouple Probes1471	Cabinets.....103, 1309, 1312, 1395-1400	Tree Trimmers369	
Thermocouple Thermometers1429, 1471, 1474-1475	Carts.....123-125, 1395, 1397, 1400	Trestle Stands209	
Thermo-Hygrometers1474, 1476	Chests.....1309-1310, 1394-1399, 1402-1403	Trestle Stepladders129-131	
Thermometer / Hygrometers645, 1472, 1474-1476	Holders.....1387-1388, 1392	Triangular Bandages729-735, 747	
Thermometers	Jobsite Boxes.....36, 1394, 1401-1407	Triangular Files1304-1305	
Bi-Metal.....1473	Pouches.....523, 1387-1388, 1390-1392	Tricycles161	
Cooking.....1471, 1473	Tops, Drum236, 670, 699	Trigger Sprayers302, 320	
Digital.....1472-1473	Toque, High Visibility549	Triggers, MIG Gun1095	
Hygrometers.....645, 1472, 1474-1476	Torch Handles1065	Trimmers, Tree369	
Indoor / Outdoor.....1472	Torch Kits, Welding1064, 1109	Tripods, Fall Protection491-492	
Infrared.....1469-1470	Torches	Tri-Wing Bits1344	
Oral.....756	Air (Gas) Cooled.....1101, 1103-1104	Trolleys, Beam190, 519	
Stem.....1473	Butane.....1080, 1083	Trowels, Drywall1053	
Surface Mount.....1473	Cutting.....1065	Truck Mounted Cranes202	
Temperature Crayons.....1142, 1445	Gas.....1064	Trucks	
Thermocouple.....1429, 1471, 1474-1475	Gouging.....1087	Appliance.....150, 1454	
Thermostatic Mixing Valves721	Propane.....1064	Box.....166, 172-175	
Thickness Gauges1478-1479	Water Cooled.....1091, 1103-1105	Drum.....246-247	
Thimbles194	Torpedo Levels1281	Gas Cylinder.....1078	
Thread Repair, Files1307	Torque Bits1343	Hand.....144-146, 148-151, 1454, 1554	
Thread Sealants1026	Torque Meters1329	Ironer.....303	
Threaded Rod Racks45	Torque Multipliers1328	Ladder.....134	
Threadlockers1020, 1027-1028	Torque Paste1342	Linen.....303	
Three Square Files1304-1305	Torque Screwdrivers1329	Pallet.....144, 182-186	
Thumb Tacks1569	Torque Wrenches1328	Panel.....158-160	
Tie-Back Lanyards509-510	Torx® Bits1343-1344	Pipe.....160-161	
Tie-Downs683, 1455-1457	Torx® Screwdrivers1339, 1341	Platform.....152-158, 160, 165	
Ties, Cable793-794, 1435, 1452	Towellettes, Benzalkonium729-735, 748	Stock.....166	
TIG Rods1136-1138, 1140	Towellettes, Lens Cleaning409, 465, 760	Tilt.....172-173	



Umbrellas, Welding1118
Undershirts552
Undershirts552
Uppers, Drum250
Upright Protectors54, 85
UPS Systems1542
Urinal Blocks349
Urinal Screens349
Utility Carts76, 166, 168-170
Utility Knives1382, 1440-1442
Utility Scales1492-1494



Vacuum Cups196-197
Vacuums
Accessories.....
.....352-353, 357-359, 361, 688, 1225
Back Pack.....357
Portable.....358
Upright.....360
Wet / Dry.....352-357, 360-361, 688
Valves
Adjusting.....1232
Ball.....1231
Butterfly.....1231
Drum.....252
Gate.....252
Safety.....1232, 1257
Water Mixing.....721
Van and Truck Equipment1407
Vane Anemometers1486
Vapor Barrier1437
Vehicle Brushes292
Vents, Drum251
Vertical Life Lines517, 520
Vertical Sheet Rack53
Vests
Cooling.....646-647
Reflective.....545-546
Traffic Control.....545-546
Winter.....552
Vibration Isolation
Anti-Vibration Pads.....1272
Cupmounts.....1272
Isolators.....1272
Leveling Mounts.....1272
Vibration Meters1484
Vinyl Tape829, 1416
Vise Grips1352
Vises
Angle.....1295
Bench.....1293-1294
Drill Press.....1295-1296
Machine.....1295
Tilting.....1295-1296
Visors410-413, 557
Voltage Testers1462, 1543

-W-

Wagons	154, 157, 370
Waiter's / Parade Gloves	625
Walkie-Talkies	435, 438-439, 441-442
Walkramps	214
Wall Barrier, Temporary	1054
Wall Clocks	1575
Wall Heaters	1504
Wall Mounted Fans	1497-1499
Wall Plates, Crowd Control	875, 877
Wallet Cards, WHMIS	846
Wands, Marking	1038-1040
Warmers, Hand	629
Warning Lights	222-223, 863, 866
Warning Systems, Horns	221
Wash Tanks	992
Washroom Cleaners	
Disinfectants.....	313-314, 318, 759-760
Toilet Bowl.....	314
Urinal.....	349
Washroom Products	
Air Fresheners.....	314, 321-322
Changing Tables.....	348
Clothes Hooks.....	350
Drain Augers.....	1375
Facial Tissue.....	344
Faucets.....	350
Grab Bar.....	350
Hand Dryers.....	351
Mirrors.....	350
Paper Towel Dispensers.....	340-343, 1583
Paper Towels.....	341-344, 346
Shelves.....	350
Toilet Augers.....	1375
Toilet Auto Flush Adapter.....	350
Toilet Paper.....	340, 345-346
Toilet Paper Dispensers.....	345-347
Toilet Plungers.....	349
Toilet Seat Cover Dispensers.....	348
Toilet Seat Covers.....	348
Urinal Screens.....	349
Washroom Sign	813
Waste Container Caddy	266
Waste Container Dollies	266, 271, 276-277
Wastebaskets	169, 267-272, 383, 1577
Water Brooms	377
Water Cooled Torches	1091, 1103-1105
Water Coolers	650
Water Filters	1585-1586
Water Fountains	1585-1586
Water Heater, Eyewash	721
Water Hoses, Welding	1110
Water Preservatives	722-723, 725
WD-40®	1004, 1012-1013
Wedge, Non-Sparking	1381
Weighting Scales	1491-1492
Weights, Test	1496
Welder's Tool Kit	1134
Welding Clothing	
Aprons.....	1132
Beanies.....	1125, 1133
Bibs.....	1132
Chaps.....	1132
Jackets.....	1132
Sleeves.....	1132
Spats.....	1132
Welding Equipment	
ADF Filters.....	1121-1122, 1124-1126, 1128
Burning Guides.....	1117
Butane Torches.....	1080, 1083
Carts.....	1078
Chest Protectors.....	1125
Chipping Hammers.....	1087-1088
Connectors.....	1084-1085
Cutting Tips.....	1065, 1070-1072
Cutting Torches.....	1065
Electrode Holders.....	1084
Electrode Ovens.....	1089
Filter Plates.....	1126, 1128
Flint Lighters.....	1073
Flowmeters.....	1068
Fume Filters.....	1058-1059
Gas Cylinder Wrenches.....	1073
Gas Torches.....	1064
Gels.....	1145
Gouging Torches.....	1087
Hand Shields.....	1123
Heating Tips.....	1072
Helmets.....	481, 1121-1127
Magnifier Plates.....	1126, 1128
MIG Guns.....	1094-1098
MIG Pliers.....	1088
MIG Welders.....	1092-1093
Neck Protectors.....	1125
Nozzle Reamers.....	1088
Outfits.....	1062-1064
Plasma Cutters.....	1069, 1090
Propane Torches.....	1064
Quick-Connects.....	1074
Racks.....	1078
Reels.....	1076
Regulator/Flowmeters.....	1068
Regulators.....	1064, 1066-1069
Respirators.....	450
Screens.....	1118-1119
Soldering & Brazing Tips.....	1064
Soldering Guns.....	1080-1082
Soldering Irons.....	1080-1082
Soldering Stations.....	1082
TIG Torches.....	1091, 1101, 1103-1110
TIG Welders.....	1091, 1113
Tip Cleaners.....	1073
Tip Refacers.....	1073
Torch Handles.....	1065
Torch Kits.....	1064, 1109
Tungsten Electrode Grinders.....	1113-1114
Umbrellas.....	1118
Weld Fillet Gauges.....	1073
Welding Harnesses	496, 500
Welding Lanyards	510
Welding Supplies	
Arrestors.....	1074
Blankets.....	1118
Brazing Alloys.....	1139
Cable Lugs.....	1085
Cable Protectors.....	1110
Cables.....	1085
Developers.....	1020, 1144
Fault Detectors.....	1012, 1020, 1144, 1148
Flints.....	1073
Flux.....	1141, 1145
Gouging Electrodes.....	1087
Ground Clamps.....	1086
Hose Fittings.....	1074
Hoses.....	1068, 1075, 1110
Matting.....	904, 1119
MIG Wire.....	1135, 1137-1138
Pads.....	1118
Rod / Electrode Containers.....	1089, 1134
Solder.....	1140
Stick Electrodes.....	1136-1137, 1139
TIG Rods.....	1136-1138, 1140
Tungsten Electrodes.....	1114
Weld-On Hinges	1088
Wet Mops	292-295, 304-306
Wheel Brushes	941-944, 1271
Wheel Chair	758
Wheel Chocks	210-211
Wheel Dollies	177, 208
Wheel Locks	782
Wheel Risers	215
Wheelbarrows	172, 370
Wheels	144-145, 148, 154, 232-233, 246
Buffing.....	937
Crimped Filament.....	912-913
Cut & Polish.....	938
Cut-Off.....	912-916
Deburring.....	936, 938, 1271
Finishing.....	938
Flap.....	919-920, 937
Grinding.....	912-917, 1271
Measuring.....	1278, 1482, 1484
Whips	
Hose.....	1250
Safety.....	856
White Glue	1029
White Lithium Greases	1018
White Lithium Lubricants	1018
Whiteboard Dry Erase Wipes	1569
Whiteboard Markers	823, 1569
Whiteboards	1569
Whitewash Brushes	292
WHMIS	
Information Charts.....	847
Labels.....	846
Pictograms.....	845-846
Posters.....	847
Wallet Cards.....	846
Winches	
Hand.....	195
Personal.....	492
Windex®	315
Window Brushes	292
Window Washers	299
Windshield De-Icer	1015
Windssocks	871
Winter Boots	635-636
Winter Clothing	
Coats.....	552
Jackets.....	552
Parkas.....	552, 555
Vests.....	552
Winter Lined Gloves	549, 571, 593, 604-605, 609, 611, 613-618, 626
Winter Liners	418, 553
Wipes	316, 318, 332, 334, 336-339, 384, 465, 759-760, 1054
Dry Erase Whiteboard.....	1569
Wipes Dispensers	334, 336, 338-340
Wire, MIG	1135, 1137-1138
Wire Basket Stretchers	755
Wire Cleaner	1143
Wire Connectors	1543
Wire Measurers	1484
Wire Mesh Bins	4
Wire Pulling Lubricants	1012, 1543
Wire Spool Carts	167
Wire Strippers	1351
Wire Stripping Pliers	1377
Wires, Bonding & Grounding	252-253, 665
Wood Fillers	1022
Wood Glue	1029
Woodworking Chisels	1367
Woodworking Machines, Bandsaws	1178
Work Boots	632-633
Work Clothing	
Aprons.....	530-531
Balaclavas.....	553
Coveralls.....	550, 554
Hard Hat Liners.....	418, 553
Lab Coats.....	550
Pants.....	550, 552
Shirts.....	550
Shop Coats.....	550
Sweatbands.....	420, 1133
Undergarments.....	552
Work Lights	1162, 1520, 1525-1528, 1530
Work Platforms	135-136, 906
Work Positioners	181
Work Stands	209, 225
Work Tables	120, 1556, 1561
Work Tents	382, 489, 647
Workbenches	103, 112-123, 125, 1432
Accessories.....	118-119
Folding.....	121
Workstations	118-119
Accessories.....	118-119
Computer.....	1559-1560
Mail.....	1566
Office.....	1567
Open Wire.....	118
Packaging.....	1433
Service Benches.....	123-125
Shipping.....	1433
Shop.....	102, 126
Work Tables.....	120, 1556, 1561
Workbenches.....	103, 112-123, 125, 1432
Worm Gear Winches	195
Wound Closures	742, 745
Wrap	
Bubble.....	1427
Shrink.....	1426
Stretch.....	1424-1426
Wraps, Cooling	645, 647
Wrecking Bars	1366
Wrenches	
Adjustable.....	1309-1312, 1330, 1332
Angle.....	1335
Box.....	1331, 1336
Bung.....	250
Chain.....	1372
Combination.....	1309-1310, 1312, 1331-1334, 1337
Compound Leverage.....	1372
Drum.....	250
End.....	1373
Flare Nut.....	1335-1336
Flex Head.....	1334-1335
Gas Cylinder.....	1073
Gear.....	1333-1334, 1337
Hex.....	1372, 1378
Impact.....	1159-1160, 1181
Impact - Air.....	1205, 1208, 1210, 1214, 1222
Non-Sparking.....	1384-1386
Offset.....	1373
Open End.....	1335
Pipe.....	1309, 1372-1373, 1378
Pump.....	1335
Ratchet - Air.....	1206, 1210
Ratcheting.....	1333-1334
Spanner.....	1330
Spud.....	1372
Straight.....	1373
Strap.....	1372
Striking Face.....	1331
Structural.....	1330
Tap.....	960, 977
Torque.....	1328
Wringers	294, 306-307
Wrist Supports	643-644, 746

-Y-

Y Connections	
Hose.....	1074