



TOOLS & EQUIPMENT



| | |
|--|-------------|
| Cordless Power Tools & Accessories | 1156 - 1167 |
| Corded Tools & Accessories | 1168 - 1189 |
| Dremel Tools, Heat Guns & Accessories..... | 1190 - 1192 |
| Cutter, Core & Drill Bits | 1193 - 1196 |
| Saw Blades | 1197 - 1203 |
| Air Tools & Accessories | 1204 - 1232 |
| Hoses, Reels & Clamps | 1233 - 1237 |
| Fittings, Couplers & Valves | 1238 - 1251 |
| Compressors & Accessories | 1252 - 1265 |
| Drill Press..... | 1266 - 1267 |
| Drill Chucks | 1268 - 1269 |
| Bench Grinders & Grinding Wheels..... | 1270 - 1271 |
| Shims, Gauges & Machinist Tools..... | 1272 - 1274 |
| Measures, Squares, Levels & Calipers..... | 1275 - 1283 |
| Vises, Magnets & Clamps..... | 1284 - 1299 |
| Hand Tool & Accessories..... | 1300 - 1308 |
| Tool Sets..... | 1309 - 1312 |
| Wrench & Socket Sets..... | 1313 - 1337 |
| Screwdrivers, Insert Bits & Hex Keys | 1338 - 1347 |
| Pliers, Knives, Scissors & Bolt Cutters | 1348 - 1361 |
| Hammers, Pry Bars, Punches & Gasket Cutters | 1362 - 1371 |
| Plumbing Tools | 1372 - 1376 |
| Non-Sparking, Non-Magnetic Tools & Insulated Tools | 1377 - 1385 |
| Tool Storage | 1386 - 1407 |



CORDLESS POWER TOOLS & ACCESSORIES

12 V 3/8" DRIVER DRILLS

- Two speed gearing
- Built-in LED light
- Ergonomic soft grip design for vibration absorption
- Includes: (2x) 12 V Lithium-Ion batteries, charger, holster and tool bag

Model No. TLV183

Mfg. No. FD02

Price/Each \$187.00

SPECIFICATIONS

| | |
|---------------------------------------|--------------------|
| Voltage: | 12 V |
| Chuck Size: | 3/8" |
| Max Torque: | 200 in.-lbs. |
| # of Speed Settings: | 2 |
| No Load RPM Setting #1: | 0-350 |
| No Load RPM Setting #2: | 0-1300 |
| Clutch Settings: | 18 |
| Chuck Type: | Ratcheting keyless |
| Tool Weight: | 2.2 lbs. |
| Replacement Battery Model No.: | TLV226 |



12 V M12™ FUEL™ 1/4" HEX 2-SPEED SCREWDRIVERS

- Redlithium™ Battery Technology delivers more work per charge and more work over pack life than any battery on the market
- Redlink Plus™ Intelligence provides optimized performance and overload protection using total system communication between tool, battery and charger
- LED light
- Includes: (2x) M12™ Redlithium™ 2.0 compact battery pack, M12™ Lithium-Ion battery charger, belt clip and hard carrying case

Model No. TLV679

Mfg. No. 2402-22

Price/Each \$269.00

SPECIFICATIONS

| | |
|---------------------------------------|------------------|
| Voltage: | 12 V |
| Chuck Size: | 1/4" |
| Max Torque: | 325 in.-lbs. |
| # of Speed Settings: | 2 |
| No Load RPM Setting #1: | 0-450 |
| No Load RPM Setting #2: | 0-1700 |
| Chuck Type: | Hex quick change |
| Tool Weight: | 2.0 lbs. |
| Replacement Battery Model No.: | TLV694 |



12 V 3/8" DRIVER DRILLS

- All metal gears for more efficient power transmission
- Compact design with a reduced body length of only 7 9/16"
- Ergonomic soft grip design for vibration absorption
- Includes: (2x) 12 V (1.3 Ah) NiCd batteries, charger and case

Model No. TLZ848

Mfg. No. 6271DWPE

Price/Each \$129.00

SPECIFICATIONS

| | |
|---------------------------------------|--------------------|
| Voltage: | 12 V |
| Chuck Size: | 3/8" |
| Max Torque: | 250 in.-lbs. |
| # of Speed Settings: | 2 |
| No Load RPM Setting #1: | 0-400 |
| No Load RPM Setting #2: | 0-1300 |
| Clutch Settings: | 16 |
| Chuck Type: | Ratcheting keyless |
| Tool Weight: | 3.3 lbs. |
| Replacement Battery Model No.: | VI457 |



12 V M12™ 1/4" HEX 2-SPEED SCREWDRIVERS

- On-board battery fuel gauge displays remaining run time
- New ergonomic handle design for increased comfort
- LED light
- Includes: (2x) M12™ Redlithium™ battery, M12™ Lithium-Ion battery charger, belt clip and carrying case

Model No. TLV676

Mfg. No. 2406-22

Price/Each \$229.00

SPECIFICATIONS

| | |
|---------------------------------------|------------------|
| Voltage: | 12 V |
| Chuck Size: | 1/4" |
| Max Torque: | 275 in.-lbs. |
| # of Speed Settings: | 2 |
| No Load RPM Setting #1: | 0-400 |
| No Load RPM Setting #2: | 0-1500 |
| Chuck Type: | Hex quick change |
| Tool Weight: | 2.2 lbs. |
| Replacement Battery Model No.: | TLZ368 |



14.4 V 3/8" DRIVER DRILLS

- All metal gears for more efficient power transmission
- Compact design with a reduced body length of only 7 9/16"
- Ergonomic soft grip design for vibration absorption
- Includes: (2x) 14.4 V (1.3 Ah) NiCd batteries, charger and case

Model No. TLZ849

Mfg. No. 6281DWPE

Price/Each \$143.00

SPECIFICATIONS

| | |
|---------------------------------------|--------------------|
| Voltage: | 14.4 V |
| Chuck Size: | 3/8" |
| Max Torque: | 320 in.-lbs. |
| # of Speed Settings: | 2 |
| No Load RPM Setting #1: | 0-400 |
| No Load RPM Setting #2: | 0-1300 |
| Clutch Settings: | 16 |
| Chuck Type: | Ratcheting keyless |
| Tool Weight: | 3.5 lbs. |
| Replacement Battery Model No.: | TLZ880 |



Refer to pages 1343 - 1345 for Screwdriver Insert Bits



APEX

18 V 1/2" DRILL DRIVER

- Compact and lightweight design
- All-metal gear construction ensures high transmission durability
- Single sleeve keyless chuck enables easy bit installation/removal with one hand
- Ergonomically designed rubberized soft grip provides more control and comfort
- Includes: (2) 1.5 Ah Li-Ion batteries and charger

Model No. TYB806
Mfg. No. DDF453SYE
Price/Each \$251.00



SPECIFICATIONS

| | |
|----------------------|-------------|
| Voltage: | 18 V |
| Chuck size: | 1/2" |
| Battery Type: | Lithium-Ion |
| No Load RPM: | 1300 |
| Max. Torque: | 27 N.m |

18 V 1/2" DRIVER DRILLS

- New battery protection system provides over-discharge, temperature and current protection for enhanced performance, battery cycle life and overall battery life
- LED job light with afterglow feature
- Ergonomic soft rubber grip and comfortable operation
- Includes: (2x) 18 V (3.0 Ah) Lithium-Ion batteries, charger, hook, plastic carrying case and double ended bit 2-45



Model No. TLV227
Mfg. No. LXF001
Price/Each \$404.00

SPECIFICATIONS

| | |
|---------------------------------------|---------------------|
| Voltage: | 18 V |
| Chuck Size: | 1/2" |
| Max Torque: | 480 in.-lbs. |
| # of Speed Settings: | 2 |
| No Load RPM Setting #1: | 0-400 |
| No Load RPM Setting #2: | 0-1500 |
| Clutch Settings: | 16 |
| Chuck Type: | Keyless drill chuck |
| Tool Weight: | 4.0 lbs. |
| Replacement Battery Model No.: | TLZ847 |

18 V 1/2" COMPACT DRILL/DRIVERS

- Compact size allows users to fit into tight spaces
- High performance frameless motor
- Built-in LED light
- Includes: (2x) 18 V NiCd batteries, charger and case

Model No. TLZ205
Mfg. No. DC720KA
Price/Each \$247.00



SPECIFICATIONS

| | |
|---------------------------------------|--------------------|
| Voltage: | 18 V |
| Chuck Size: | 1/2" |
| Max Torque: | 410 UWO |
| # of Speed Settings: | 2 |
| No Load RPM Setting #1: | 0-500 |
| No Load RPM Setting #2: | 0-1700 |
| Clutch Settings: | 17 |
| Chuck Type: | Ratcheting keyless |
| Tool Weight: | 4.8 lbs. |
| Replacement Battery Model No.: | TT906 |

18 V XRP DRILLS/DRIVERS

- 3-speed all-metal transmission
- High power, high efficiency motor
- Built-in LED light
- Includes: (2x) 18 V NiCd batteries, charger, side handle and case



Model No. TLZ874
Mfg. No. DCD940KX
Price/Each \$357.00

SPECIFICATIONS

| | |
|---------------------------------------|--------------------|
| Voltage: | 18 V |
| Chuck Size: | 1/2" |
| Max Torque: | 450 UWO |
| # of Speed Settings: | 3 |
| No Load RPM Setting #1: | 0-500 |
| No Load RPM Setting #2: | 0-1250 |
| No Load RPM Setting #3: | 0-2000 |
| Clutch Settings: | 22 |
| Chuck Type: | Ratcheting keyless |
| Tool Weight: | 6.25 lbs. |
| Replacement Battery Model No.: | TT906 |

12 V M12™ 3/8" HAMMER DRILL/DRIVERS

- On-board battery fuel gauge displays remaining run time
- New ergonomic handle design for increased comfort
- LED light
- Includes: (2x) M12™ Redlithium™ battery, M12™ Lithium-Ion battery charger, belt clip and carrying case

Model No. TLV677
Mfg. No. 2408-22
Price/Each \$263.00



SPECIFICATIONS

| | |
|---------------------------------------|------------------|
| Voltage: | 12 V |
| Chuck Size: | 3/8" |
| Max Torque: | 275 in.-lbs. |
| # of Speed Settings: | 2 |
| No Load RPM Setting #1: | 0-400 |
| No Load RPM Setting #2: | 0-1500 |
| Chuck Type: | Metal ratcheting |
| Tool Weight: | 2.7 lbs. |
| Replacement Battery Model No.: | TLZ368 |

12 V M12 FUEL™ 1/2" HAMMER DRILL/DRIVERS

- Redlink Plus™ Intelligence provides optimized performance and overload protection using total system communication between tool, battery and charger
- Redlithium™ Battery Technology delivers more work per charge and more work over pack life than any battery on the market
- Includes: M12™ Redlithium™ 2.0 compact battery pack, M12™ Redlithium™ XC 4.0 extended capacity battery pack, M12™ lithium-ion battery charger, belt clip and carrying case

Model No. TLV678
Mfg. No. 2404-22
Price/Each \$310.00



SPECIFICATIONS

| | |
|---------------------------------------|---------------------------------------|
| Voltage: | 12 V |
| Chuck Size: | 1/2" |
| Max Torque: | 350 in.-lbs. |
| # of Speed Settings: | 2 |
| No Load RPM Setting #1: | 0-450 |
| No Load RPM Setting #2: | 0-1700 |
| Chuck Type: | Metal single sleeve - ratcheting lock |
| Tool Weight: | 2.9 lbs. |
| Replacement Battery Model No.: | TLV694 |

CORDLESS POWER TOOLS & ACCESSORIES

18 V 1/2" HAMMER DRIVER DRILLS

- Compact and lightweight design (only 9 7/16" length)
- Soft rubber grip design for vibration absorption
- Includes: (2x) 18 V (compact) Lithium-Ion batteries, charger, battery cover, double ended bit, hook and plastic carrying case

Model No. TLV229
Mfg. No. BHP453H
Price/Each \$259.00

SPECIFICATIONS

| | |
|---------------------------------------|------------------|
| Voltage: | 18 V |
| Chuck Size: | 1/2" |
| Max Torque: | 340 in.-lbs. |
| # of Speed Settings: | 2 |
| No Load RPM Setting #1: | 0-400 |
| No Load RPM Setting #2: | 0-1300 |
| Clutch Settings: | 16 |
| Chuck Type: | Keyless drill ch |
| Tool Weight: | 2.9 lbs. |
| Replacement Battery Model No.: | TLZ854 |



20 V MAX BRUSHLESS 3-SPEED HAMMER DRILL

- High efficiency brushless motor provides superior power
- XR Li-Ion batteries with fuel gauge provide 33% more capacity
- Improved LED Light placement minimizes chuck shadows
- Compact size, 8.4" front-to-back length fits tight areas
- Includes: (2) 20 V MAX* XR High Capacity Li-Ion Batteries (4.0Ah), fast charger, Belt hook, 360° side handle and kitbox

Model No. TYD753
Mfg. No. DCD995M2
Price/Each \$499.00

SPECIFICATIONS

| | |
|---------------------------------------|-------------------|
| Voltage: | 20 V |
| Chuck Size: | 1/2" |
| Max Torque: | 650 UWO |
| Battery Type: | Lithium-Ion |
| # of Speed Settings: | 3 |
| No Load RPM: | 2000 |
| BPM: | 34000 |
| Clutch Settings: | 11 |
| Chuck Type: | Metal, ratcheting |
| Tool Weight: | 4.7 lbs. |
| Replacement Battery Model No.: | TLV657 |



18 V XRP HAMMER DRIVER DRILLS

- 3-speed all-metal transmission
- High power, high efficiency motor
- Built-in LED light
- Includes: (2x) 18 V NiCd batteries, charger, side handle and case

Model No. TLZ875
Mfg. No. DCD950KX
Price/Each \$377.00

SPECIFICATIONS

| | |
|---------------------------------------|--------------------|
| Voltage: | 18 V |
| Chuck Size: | 1/2" |
| Max Torque: | 450 UWO |
| # of Speed Settings: | 3 |
| No Load RPM Setting #1: | 0-500 |
| No Load RPM Setting #2: | 0-1250 |
| No Load RPM Setting #3: | 0-2000 |
| Max BPM Setting #1: | 0-8500 |
| Max BPM Setting #2: | 0-21250 |
| Max BPM Setting #3: | 0-34000 |
| Clutch Settings: | 22 |
| Chuck Type: | Ratcheting keyless |
| Tool Weight: | 6.25 lbs. |
| Replacement Battery Model No.: | TT906 |



M18 FUEL™ 1/2" DRILL/DRIVER KIT

- Chuck Type: Metal Single Sleeve - Ratcheting Lock
- POWERSTATE™ Brushless Motor: Delivers up to 725 in lbs of torque with maximum sustained torque to complete the toughest of applications
- REDLITHIUM™ Battery Technology: Superior pack construction, electronics, and performance deliver more work per charge and more work over pack life than any battery on the market
- REDLINK PLUS™ Intelligence: The most advanced system of cordless power tool electronics. Provides optimized performance and overload protection using total system communication between tool, battery and charger.
- Includes : (1) M18 FUEL™ 1/2" Drill/Driver, (2) M18™ REDLITHIUM™ XC 4.0 Extended Capacity Battery Pack, (1) M18™ & M12™ Multi-Voltage Charger, (1) Carrying Case

Model No. TMB548
Mfg. No. 2703-22
Price/Each \$496.00

SPECIFICATIONS

| | |
|-----------------------------|--------------|
| Voltage: | 18 V |
| Chuck Size: | 1/2" |
| Replacement Battery: | Lithium-Ion |
| No Load RPM: | 2000 |
| Max Torque: | 725 in.-lbs. |



18 V M18™ 1/2" COMPACT DRILL/DRIVERS

- Compact, ergonomic drill/driver with an all-metal gear case for maximum durability
- Most compact drill/driver in its class
- Includes: (2) M18™ Redlithium™ compact battery, multi-voltage 12 V-18 V charger and carrying case

Model No. TLV700
Mfg. No. 2606-22CT
Price/Each \$299.00

SPECIFICATIONS

| | |
|---------------------------------------|--------------|
| Voltage: | 18 V |
| Chuck Size: | 1/2" |
| Max Torque: | 500 in.-lbs. |
| # of Speed Settings: | 2 |
| No Load RPM Setting #1: | 0-450 |
| No Load RPM Setting #2: | 0-1800 |
| Max BPM: | 0-29000 |
| Clutch Settings: | Adjustable |
| Chuck Type: | 1/2" metal |
| Tool Weight: | 3.6 lbs. |
| Replacement Battery Model No.: | TLZ453 |



18 V M18™ 1/2" COMPACT HAMMER DRILLS/DRIVERS

- Compact, ergonomic hammer drill/driver with an all-metal gear case for maximum durability
- Redlithium™ Battery Pack provides more work per charge and more work over battery pack life
- Includes: (2) M18™ Redlithium™ XC high capacity battery, multi-voltage 12 V-18 V charger and carrying case

Model No. TLV701
Mfg. No. 2607-22
Price/Each \$399.00

SPECIFICATIONS

| | |
|---------------------------------------|--------------|
| Voltage: | 18 V |
| Chuck Size: | 1/2" |
| Max Torque: | 525 in.-lbs. |
| # of Speed Settings: | 2 |
| No Load RPM Setting #1: | 0-450 |
| No Load RPM Setting #2: | 0-1800 |
| Max BPM: | 0-28800 |
| Clutch Settings: | Adjustable |
| Chuck Type: | 1/2" metal |
| Tool Weight: | 3.7 lbs. |
| Replacement Battery Model No.: | TLZ452 |



18 V M18™ FUEL™ 1/2" HAMMER DRILL/DRIVERS



- RedLithium™ Battery Technology delivers more work per charge and more work over pack life than any battery on the market
- Powerstate™ Brushless Motor: Delivers up to 725 in-lbs. of torque with maximum sustained torque to complete the toughest of applications
- Redlink Plus™ Intelligence provides optimized performance and overload protection using total system communication between tool, battery and charger
- Includes: (2) M18™ XC high capacity batteries and multi-voltage charger

Model No. TLV501
Mfg. No. 2704-22
Price/Each \$499.00

SPECIFICATIONS

| | |
|---------------------------------------|--|
| Voltage: | 18 V |
| Chuck Size: | 1/2" |
| Max Torque: | 725 in-lbs. |
| # of Speed Settings: | 2 |
| No Load RPM Setting #1: | 0-550 |
| No Load RPM Setting #2: | 0-1850 |
| Max BPM: | 0-31 450 |
| Chuck Type: | 1/2" metal single sleeve - ratcheting lock |
| Tool Weight: | 3.7 lbs. |
| Replacement Battery Model No.: | TLZ453 |



28 V M28™ HAMMER DRILLS



- Revolutionary 28 V lithium-ion technology
- 750 in-lbs. of maximum torque
- 1-2" all-metal, single-sleeve ratcheting chuck with carbide jaws
- Up to 2X run-time of 18 V tools
- Includes: (2x) 28 V Lithium-Ion batteries, charger, side handle, no. 2 Phillips bit

Model No. TLV092
Mfg. No. 0726-22
Price/Each \$749.00

SPECIFICATIONS

| | |
|---------------------------------------|------------------------------------|
| Voltage: | 28 V |
| Chuck Size: | 1/2" |
| Max Torque: | 750 in-lbs. |
| # of Speed Settings: | 2 |
| No Load RPM Setting #1: | 0-450 |
| No Load RPM Setting #2: | 0-1800 |
| Clutch Settings: | 24 |
| Chuck Type: | Ratcheting chuck with carbide jaws |
| Tool Weight: | 6.7 lbs. |
| Replacement Battery Model No.: | TGX012 |



18 V M18™ 5/8" SDS PLUS ROTARY HAMMERS



- Delivers up to 20% faster drilling and 50% longer life
- Lightweight and compact
- Ideal for drilling in tight spaces and overhead
- LED light
- Two drilling modes: Rotary Hammer and Hammer Only
- Includes: (2x) M18™ XC high capacity RedLithium™ battery, M18™ and M12™ multi-voltage charger, carrying case, depth rod and side handle

Model No. TLV683
Mfg. No. 2612-22
Price/Each \$682.00

SPECIFICATIONS

| | |
|---------------------------------------|-------------|
| Voltage: | 18 V |
| Chuck Size: | 5/8" |
| Max Torque: | 275 in-lbs. |
| # of Speed Settings: | 1 |
| No Load RPM: | 0-1300 |
| Max BPM: | 0-7000 |
| Tool Weight: | 5.5 lbs. |
| Replacement Battery Model No.: | TLZ452 |



12 V M12™ FUEL™ 1/4" HEX IMPACT DRIVERS



- RedLithium™ 2.0 Battery Technology delivers more work per charge and more work over pack life than any battery on the market
- Redlink Plus™ Intelligence provides optimized performance and overload protection using total system communication between tool, battery and charger
- Drive Control™: Two fastening modes provide variable power and speed for precision work and heavy duty applications
- Includes: (2x) M12™ RedLithium™ 2.0 compact battery pack, M12™ Lithium-Ion battery charger, belt clip and carrying case

Model No. TLV682
Mfg. No. 2453-22
Price/Each \$273.00

SPECIFICATIONS

| | |
|---------------------------------------|--------------|
| Voltage: | 12 V |
| Chuck Size: | 1/4" |
| Max Torque: | 1200 in-lbs. |
| # of Speed Settings: | 1 |
| No Load RPM: | 0-2650 |
| Max BPM: | 0-3550 |
| Tool Weight: | 2.2 lbs. |
| Replacement Battery Model No.: | TLV694 |



18 V M18™ 1/4" COMPACT IMPACT DRIVERS

- RedLithium™ Battery Pack provides more work per charge and more work over battery pack life
- Rubber overmold
- Includes: (2) M18™ RedLithium™ XC batteries, belt clip, multi-voltage 12 V-18 V charger and carrying case

Model No. TLV702
Mfg. No. 2657-22
Price/Each \$474.00

SPECIFICATIONS

| | |
|---------------------------------------|------------------------|
| Voltage: | 18 V |
| Chuck Size: | 1/4" Hex Quick Connect |
| Max Torque: | 1500 in-lbs. |
| # of Speed Settings: | 1 |
| No Load RPM: | 0-2700 |
| Max BPM: | 0-3400 |
| Tool Weight: | 3.6 lbs. |
| Replacement Battery Model No.: | TLZ453 or TLZ452 |



M18 FUEL™ 1-1/8" SDS PLUS ROTARY HAMMER & HAMMERVAC™ DUST EXTRACTOR KIT

- FUEL™ technology delivers faster than corded speed and durability
- Anti-Vibration System minimizes vibration for maximum comfort
- HAMMERVAC™ Dedicated Dust Extractor connects directly to the rotary hammer
- High Capacity Dust Box allows user to go longer without emptying dust box as often
- Replaceable Certified HEPA Filter: Filters 99.97% of all particles greater than 0.3 µm
- Includes: Rotary hammer, HAMMERVAC™ Dedicated Dust Extractor, Charger, (2) M18™ REDLITHIUM™ XC 4.0 Battery Pack, HEPA Filter, Nozzle, Depth Rod, Side Handle and Carrying Case

Model No. TYO318
Mfg. No. 2715-22DE
Price/Each \$999.00

SPECIFICATIONS

| | |
|---------------------------------------|-------------|
| Voltage: | 18 V |
| Chuck Size: | 1 1/8" |
| Battery Type: | Lithium-Ion |
| Max. Torque: | 3.3 ft-lbs |
| # of Speed Settings: | 5000 |
| No Load RPM: | 1350 |
| Max BPM: | 5000 |
| Replacement Battery Model No.: | TLV635 |



18 V M18™ 1/2" IMPACT WRENCHES

- Lightweight new design
- Rubber overmold
- Includes: (2) M18™ Redlithium™ XC battery, multi-voltage 12 V-18 V charger and carrying case

Model No. TLV704
Mfg. No. 2659-22
Price/Each \$539.00

SPECIFICATIONS

| | |
|---------------------------------------|-----------------|
| Voltage: | 18 V |
| Socket Size: | 1/2" Pin Detent |
| Max Torque: | 2200 in.-lbs. |
| # of Speed Settings: | 1 |
| No Load RPM: | 0-2450 |
| Max BPM: | 0-3350 |
| Tool Weight: | 4.1 lbs. |
| Replacement Battery Model No.: | TLZ452 |



Milwaukee

18V 1/2" CORDLESS IMPACT WRENCH

- Compact and lightweight design with high maximum fastening torque
- Same fastening torque in forward and reverse rotation
- Rubber joint construction suppresses transmission of vibration to battery, minimizing battery failures due to terminal breakage or poor electrical contact
- Rubber bumper protects material from damage
- Easy to operate On/Off rocker switch
- 1 3/4" wide hook enables tool to be hung on rafters, pipes, etc. when not immediately in use
- LED Light with afterglow feature and independent On/Off Switch
- Ergonomic soft rubber grip design for vibration absorption and comfortable operation
- Includes: 2 18V (5.0 Ah) Li-Ion batteries, charger, hook, battery cover, plastic carrying case

Model No. TYL031
Mfg. No. DTW450RTE
Price/Each \$859.00

Makita

SPECIFICATIONS

| | |
|----------------------------|--------------|
| Voltage: | 18 V |
| Socket Size: | 1/2" |
| Max Torque: | 325 ft.-lbs. |
| No Load RPM: | 0-1600 |
| Impacts per minute: | 2200 |
| Noise Level: | 94 dB(A) |
| Weight: | 7.5 lbs. |



18 V M18™ FUEL™ 1/2" IMPACT WRENCHES W/FRICTION RING

- The M18™ Fuel™ high torque impact wrench is the most powerful 18-volt cordless impact wrench in its class
- 1/2" friction ring anvil allows to make quick and tool-free socket changes
- Includes: (2) M18™ Redlithium™ XC 4.0 extended capacity battery pack, M18™ and M12™ multi-voltage charger and carrying case

Model No. TLV705
Mfg. No. 2763-22
Price/Each \$699.00

SPECIFICATIONS

| | |
|---------------------------------------|-----------------------------|
| Voltage: | 18 V |
| Socket Size: | 1/2" Square - Friction Ring |
| Max Torque: | 7.0 ft.-lbs. |
| # of Speed Settings: | 1 |
| No Load RPM: | 0-1700 |
| Max BPM: | 0-2400 |
| Tool Weight: | 7.2 lbs. |
| Replacement Battery Model No.: | TLV635 |



Milwaukee

18V LXT 1/2" IMPACT WRENCH

- 4-pole motor design with dual steel ball bearings provides maximum torque
- Hammer case cover protects work piece from scratches, increasing maneuverability
- Built-in L.E.D. light for more illuminated accurate work
- Includes: 2 x 3.0Ah Lithium-ion batteries, charger, belt clip and carry case

Model No. TYL019
Mfg. No. DTW251RFE
Price/Each \$553.00

Makita

SPECIFICATIONS

| | |
|---------------------------------------|--------------|
| Voltage: | 18 V |
| Socket Size: | 1/2" |
| Battery Type: | Lithium-Ion |
| Max Torque: | 170 ft.-lbs. |
| No Load RPM: | 2400 |
| Max BPM: | 3200 |
| Tool Weight: | 3.7 lbs. |
| Replacement Battery Model No.: | TLZ847 |



18 V M18™ FUEL™ 7/16" IMPACT WRENCHES

- M18™ Fuel™ high torque impact wrench is the most powerful 18-volt cordless impact wrench in its class
- The 7/16" quick connect allows users fast, secure insertion/removal of auger bits and socket adapters
- Includes: (2) M18™ Redlithium™ XC 4.0 extended capacity battery pack, M18™ and M12™ multi-voltage charger and carrying case

Model No. TLV706
Mfg. No. 2765-22
Price/Each \$807.00

SPECIFICATIONS

| | |
|---------------------------------------|-------------------------|
| Voltage: | 18 V |
| Socket Size: | 7/16" Hex Quick Connect |
| Max Torque: | 4.5 ft.-lbs. |
| # of Speed Settings: | 1 |
| No Load RPM: | 0-1700 |
| Max BPM: | 0-2400 |
| Tool Weight: | 7.5 lbs. |
| Replacement Battery Model No.: | TLV635 |



Milwaukee

18 V 1/2" HEAVY-DUTY XRP™ IMPACT WRENCHES

- Frameless motor with replaceable brushes for extended tool durability and life
- Compact size and lightweight design allows user to get into tight spaces
- Heavy-duty impact mechanism directs torque to fastener without kickback
- Includes: (2) 18 V XRP™ batteries, 1 hour charger and kit box

Model No. TLZ206
Mfg. No. DC820K
Price/Each \$369.00

SPECIFICATIONS

| | |
|---------------------------------------|--------------|
| Voltage: | 18 V |
| Socket Size: | 1/2" |
| Max Torque: | 145 ft.-lbs. |
| No Load RPM: | 0-2400 |
| Tool Weight: | 4.6 lbs. |
| Replacement Battery Model No.: | TT906 |



DEWALT

4 V M4™ 1/4" HEX SCREWDRIVERS

- 21-position clutch setting with auto shut-off
- Includes: (2x) M4™ 2.0 battery and M4™ charger

Model No. TLV684
Mfg. No. 2101-22
Price/Each \$215.00

SPECIFICATIONS

| | |
|--------------------------------|-------------|
| Voltage: | 4 V |
| Chuck Size: | 1/4" Hex |
| Maximum Torque: | 44 in.-lbs. |
| # of Speed Settings: | 2 |
| # of Speed Settings: | 2 |
| No Load RPM Setting #1: | 0-200 |
| No Load RPM Setting #2: | 0-600 |
| Clutch Settings: | 21 |
| Tool Weight: | 0.85 lbs. |
| Replacement Battery | |
| Model No.: | TLV691 |



Milwaukee

7.2 V LITHIUM-ION IMPACT DRIVERS

- Built-in LED light
- Forward and reverse switch
- Lightweight, compact design
- Includes: (2) 7.2 V DC (1.0 Ah) Lithium-Ion batteries, charger, bit set (Phillips No. 2-45; No. 1-45; No. 2-45; drill bit 1/8" and soft carrying case

Model No. TJZ791
Mfg. No. DF010DSE
Price/Each \$159.00

SPECIFICATIONS

| | |
|----------------------------|-------------|
| Voltage: | 7.2 V |
| Maximum Torque: | 50 in.-lbs. |
| No Load RPM: | 0-200 |
| Max BPM: | 0-650 |
| Tool Weight: | 1.2 lbs. |
| Replacement Battery | |
| Model No.: | TNB485 |



Makita

8 V MAX* GYROSCOPIC SCREWDRIVERS

- Good for fastening into wood, plastic and light-gauge metal
- Variable speed & reversing controls
- Adjustable 2-position handle allows for operation in either in-line or pistol-grip
- Built-in LED light
- Includes: 8 V MAX* compact battery, 1 hour charger and kit bag

Model No. TLV653
Mfg. No. DCF680N1
Price/Each \$128.00

SPECIFICATIONS

| | |
|----------------------------|----------|
| Voltage: | 8 V |
| Chuck Size: | 1/4" Hex |
| No Load RPM: | 0-430 |
| Tool Weight: | 1.1 lbs. |
| Replacement Battery | |
| Model No.: | TNB487 |



DEWALT

M12™ 3/8" RIGHT ANGLE DRILL DRIVERS

- 3/8" single sleeve ratcheting chuck
- 3 3/4" head length, great for working in tight spaces
- Extended paddle switch
- Battery fuel gauge
- Built-in LED light
- Includes: 12 V Lithium-Ion battery pack, 12 V charger and carrying case

Model No. TLV038
Mfg. No. 2415-21
Price/Each \$229.00

SPECIFICATIONS

| | |
|-----------------------------|--------------------------|
| Voltage: | 12 V |
| Chuck Size: | 3/8" |
| Maximum Torque: | 100 in.-lbs. |
| # of Speed Settings: | 1 |
| No Load RPM: | 0-800 |
| Clutch Settings: | 11 |
| Chuck Type: | Single sleeve ratcheting |
| Tool Weight: | 2.43 lbs. |
| Replacement Battery | |
| Model No.: | TLZ368 |



Milwaukee

M12™ GREASE GUNS

- Powerful 12 V motor: Delivers over 8000 PSI max operating pressure
- Best in class run-time: Dispenses up to 7 cartridges per charge
- Superior handle balance and ergonomics: Only 14" long and 7.2 lbs.
- Integrated hose storage and LED fuel gauge: Added user convenience and less down time
- Air bleeder valve: Priming mechanism for quick flow
- M12™ Lithium-Ion System: Compatible with over 20 M12™ lithium-ion tools for greater versatility in the workplace
- Maximum durability: Backed by a 5-year warranty
- Includes: M12™ XC Lithium-Ion battery pack, 30-minute charger, 36" flex hose with spring guard, grease coupler and carrying case

Model No. TLV192
Mfg. No. 2446-21XC
Price/Each \$327.00

SPECIFICATIONS

| | |
|----------------------------|--|
| Voltage: | 12 V |
| Output Pressure: | Over 8000 PSI |
| Grease Capacity: | 14-oz. cartridge 16-oz. bulk |
| Hose Type: | 36" high pressure flex hose w/spring guard |
| Tool Weight: | 7.2 lbs. |
| Replacement Battery | |
| Model No.: | TLV039 |



Milwaukee

20 V MAX LITHIUM ION GREASE GUN

- High-volume pump pushes up to 5.0 oz./min high-flow applications
- Up to 16 cartridges per charge
- Variable speed trigger offers precise control of the grease flow
- 42" extra-long and flexible hose designed for reaching hard to access grease fittings
- Includes: 20 V MAX XR premium Li-ion battery (4.0 Ah), fast charger, shoulder strap and kit box

Model No. TYD766
Mfg. No. DCG571M1
Price/Each \$429.00

SPECIFICATIONS

| | |
|----------------------------|-------------|
| Voltage: | 20 V |
| Output Pressure: | 10000 PSI |
| Battery Type: | Lithium-Ion |
| Cartridge Size: | 14 oz. |
| Replacement Battery | |
| Model No.: | TLV657 |



DEWALT

18 V CIRCULAR SAWS

- Easy-to-read aircraft aluminium shoe
- 18 V XC high capacity Lithium-Ion battery provides up to 20% more torque
- Battery fuel gauge
- Includes: (2x) 18 V high capacity Lithium-Ion batteries, charger and tool bag

Model No. TLZ450
Mfg. No. 2630-22
Price/Each \$569.00

SPECIFICATIONS

Voltage: 18 V
Blade Diameter: 6 1/2"
No Load RPM: 3500
Capacity @ 90°: 2 1/8"
Capacity @ 45°: 1 5/8"
Spindle Lock: Yes
Electric Brake: Yes
Arbor: 5/8"
Blade Guard Material: Magnesium
Shoe Material: Aircraft aluminium
Tool Weight: 8.5 lbs.
Replacement Battery Model No.: TLZ452



Milwaukee

18 V M18™ METAL SAWS

- Compact, low-profile design for increased control
- Extra-large cut guide, impact resistant window and LED light for more accurate cut
- Superior Cut Quality - 30T Metal Tech™ carbide-tipped blade
- Tool-free depth adjustment quickly and easily adjusts cutting depth from 1/8"-2"
- Includes: (2x) M18 XC™ high capacity RedLithium™ battery packs, charger, 30T Metal Tech™ carbide-tipped blade, blade wrench and contractor bag

Model No. TLV190
Mfg. No. 2682-22
Price/Each \$623.00

SPECIFICATIONS

Voltage: 18 V
Blade Diameter: 6 1/2"
No Load RPM: 3600
Capacity @ 90°: 2"
Arbor: 6/8"
Blade Guard Material: Polycarbonate
Shoe Material: Stainless steel
Tool Weight: 5.8 lbs.
Replacement Battery Model No.: TLZ452



Milwaukee

FORCELOGIC™ M18™ 10 TON KNOCKOUT TOOL 1/2"-2" KIT

- Powerful enough to punch holes in 10 gauge mild steel and 12 gauge stainless steel
- Quick Connect Alignment System allows for easy set-up without the tool
- Exact™ 1/2" - 2" Punches and Dies with cross-hairs for accurate holmaking
- Includes : 2 M18™ REDLITHIUM™ XC Extended Capacity Batteries, Multi-Voltage Charger, EXACT™ 1/2" Stainless Steel Die, EXACT™ 1/2" Stainless Steel Punch, EXACT™ 3/4" Die, EXACT™ 3/4" Punch, EXACT™ 1" Die, EXACT™ 1" Punch, EXACT™ 1-1/4" Die, EXACT™ 1-1/4" Punch, EXACT™ 1-1/2" Die, EXACT™ 1-1/2" Punch, EXACT™ 2" Die, EXACT™ 2" Punch, 7/16" Draw Stud, 3/4" Draw Stud, Coupler, Quick Connect Collar and Carrying Case

Model No. TYO317
Mfg. No. 2676-22
Price/Each \$2335.00

SPECIFICATIONS

Voltage: 18 V
Punch Capacity: Up to 2"
Output Force: 10 tons
Power Source: Cordless
Replacement Battery Model No.: TLZ452



Milwaukee

M18™ LED FLOOD LIGHT

- Up to 30% brighter than corded 250 halogen lights
- Innovative roll cage design
- Versatile hanger provides hands-free use in a variety of applications
- Up to 8 hours of run-time
- **Runs on M18™ batteries (not included)**
- Battery and charger sold separately
- Dimensions: 6-1/4" L x 6-1/4" W x 6-1/4" H
- Lamp type: LED
- Lumens: 160
- Wattage: 8 W
- Lamp life: 50000 hrs.
- Housing material: Rubber
- Colour: Red

Model No. TYD830
Mfg. No. 2361-20
Price/Each \$163.00



Milwaukee

M12™ WORK LIGHTS

- 90° pivoting head
- Xenon incandescent bulb
- Integrated magnet provides hands-free use
- Runs on M12™ battery (not included)

Model No. TLZ369
Mfg. No. 49-24-0145
Price/Each \$34.80



Milwaukee

18 V M18™ LED WORK LIGHTS

- Sealed, aluminum head – Impact and weather resistant
- 160 lumen LED – Bright, white, smooth beam
- Integrated hook – Hands-free use
- 135° rotating head
- Runs on M18™ battery (not included)
- Tool length: 8 1/2"
- Tool weight: 1 lbs.

Model No. TLV686
Mfg. No. 2735-20
Price/Each \$86.30



Milwaukee

18V LXT® LED FLASHLIGHT

- Flashlight head folds up and down with 7 positive stops and rotates left to right for multiple lighting angles
- Metal hang hook swivels 360° and folds away for extra convenience
- Compact and ergonomic design at only 15" long
- Rubberized soft grip provides increased comfort on the job
- Battery and charger sold separately
- 1-year warranty on flashlight
- Lamp type: LED
- Lumens: 240 (High); 120 (Low)
- Run time hrs.: 22 (High); 30 (Low)
- Material: Polymer
- Batteries required: 18V LXT Lithium-Ion 3AH
- Colour: Blue
- Beam distance: 10 m
- Batteries not included

Model No. TYO321
Mfg. No. DML801
Price/Each \$62.10



Makita

HEAVY-DUTY FLASHLIGHTS

- High quality construction
- 4-position pivoting head
- Uses standard pod style Makita battery (not included)
- Lightweight design



Makita

| Model No. | Mfg. No. | Volts | Price/Each |
|-----------|----------|-------|------------|
| TJ128 | ML180 | 18 | 73.80 |
| TJ129 | ML140 | 14.4 | 69.90 |
| TJ134 | ML120 | 12 | 56.90 |

CORDLESS ANGLE GRINDERS

- Electronic current limiter with warning light prevents motor burnout caused by overloading
- Anti-restart feature prevents accidental start up of tool during battery changing
- Removable side handle can be mounted on either side of grinder body
- Conveniently located thumb switch for operator comfort
- Includes: Plastic carrying case, 2 batteries, 1 charger included

Model No. TYL146
Mfg. No. DGA452RFE
Price/Each \$522.00



SPECIFICATIONS

Voltage: 18 V
Wheel Size: 4-1/2"
Battery Type: Lithium-Ion
No Load RPM: 10000
Spindle Size: 5/8"
Tool Weight: 5.1 lbs.

CORDLESS ANGLE GRINDERS

- Brushless motor: Delivers maximum power and up to 10X longer motor life
- Redlink Plus™ Intelligence provides optimized performance, electronic clutch, and overload protection using total system communication between tool, battery and charger
- Same metal housing and gearing system as legendary high performance corded grinders
- Paddle-switch design
- Includes: Plastic carrying case, 2 batteries, 1 charger

Model No. TYD891
Mfg. No. 2780-22
Price/Each \$664.00



SPECIFICATIONS

Voltage: 18 V
Wheel Size: 5"
Battery Type: REDLITHIUM™ Lithium-Ion
No Load RPM: 8500
Spindle Size: 5/8"
Tool Weight: 5.8 lbs.

18 V GRINDERS

- L-shape vents keep debris from entering the tool
- Overload protection to prevent overheating
- Tool free guard adjustment, paddle switch design
- Includes: (2x) 18 V XC Lithium-Ion batteries, cutting wheel, tool bag, wrench, side handle and charger

Model No. TLV035
Mfg. No. 2680-22
Price/Each \$559.00



SPECIFICATIONS

Voltage: 18 V
Wheel Diameter: 4 1/2"
No Load RPM: 9000
Spindle Size: 5/8"
Spindle Lock: Yes
Tool Weight: 5.9 lbs.
Replacement Battery Model No.: TLZ452

M12™ ROTARY TOOLS

- Powerful motor: Unmatched performance under load
- 1/8" collet: Compatible with all current rotary tool accessories
- Variable speed (5000-32 000): Up to 10% faster than the competition
- Compact and lightweight: Only 9.5" long and 1.3 lbs.
- Milwaukee durability: Grinder style exhaust ports and protected front bearing deliver up to 10X the tool life
- Includes: M12™ Redlithium™ battery, (5x) cutting wheels, mandrel, wrench and 30-minute charger

Model No. TLV193
Mfg. No. 2460-21
Price/Each \$179.00



SPECIFICATIONS

Voltage: 12 V
No of Speed Settings: 2
No Load RPM Setting #1: 0-5000
No Load RPM Setting #2: 0-32000
Tool Weight: 1.3 lbs.
Replacement Battery Model No.: TLZ368

18 V SAWZALL® RECIPROCATING SAWS

- Low vibration high speed functioning
- Lever action Quik-Lok™ blade clamp
- Patented gear-protecting clutch
- Includes: (2x) 18 V high capacity Lithium-Ion batteries, saw blade, charger and tool bag

Model No. TLZ449
Mfg. No. 2621-22
Price/Each \$499.00



SPECIFICATIONS

Voltage: 18 V
Max strokes per minute (SPM): 0-3200
Stroke Length: 1"
Tool Weight: 7.9 lbs.
Replacement Battery Model No.: TLZ452

18 V M18™ FUEL™ SAWZALL®

- Features a keyless Adjustable shoe, integrated LED light, and a rafter hook for easy storage
- Quik-Lok® Universal blade clamp for quick tool-free blade changes
- Includes: (2) M18™ Redlithium™ XC 4.0 extended capacity battery pack, M18™ and M12™ multi-voltage charger, blade and carrying case

Model No. TLV707
Mfg. No. 2720-22
Price/Each \$646.00



SPECIFICATIONS

Voltage: 18 V
Max strokes per minute (SPM): 0-3000
Stroke Length: 1 1/8"
Tool Weight: 8.9 lbs.
Replacement Battery Model No.: TLV635

20 V MAX XR DUAL SPEED FRAMING NAILER

- Brushless motor and engine design provides enough power to drive 3-1/2" nails
- Dual speed optimizes motor speed for different nail lengths
- Accepts 30-34 degree paper tape nails
- Clipped head or Offset Full Round Head
- Includes: (1) 20 V MAX® XR Premium Li-Ion Battery (4.0 Ah), charger and No-Mar Tip

Model No. TYD774
Mfg. No. DCN692M1
Price/Each \$829.00

SPECIFICATIONS

Voltage: 20 V
Battery Type: Lithium-Ion
Nail Diameter: .113 - .131 gauge
Nail Length Capacity: 2" to 3-1/2"
Magazine Angle: 33°
Magazine Capacity: 55



See page 1201 for
 Reciprocating Saw Blades



CORDLESS POWER TOOLS & ACCESSORIES

18 V COMBO KITS

- M18™ 1/2" compact drill/driver delivers 400 in-lbs. of torque and is only 4 lbs. and 7 3/4" long
- M18™ 1/4" hex compact impact with the Milwaukee® 4-pole frameless motor delivers 1400 in-lbs. of torque
- Includes: (2x) 18 V Redlithium™ compact batteries, charger, carrying case

Model No. TLZ887
Mfg. No. 2691-22
Price/Each \$339.00

SPECIFICATIONS

Voltage: 18 V
Replacement Battery Model No.: TLZ453



Milwaukee

12V MAX LI-ION DRILL/DRIVER & IMPACT DRIVER COMBO

- Battery Type: Lithium-Ion
- 12V MAX 3/8" drill/driver features two speed transmission (0-400 / 0-1,500)
- 12V MAX 1/4" impact driver features 3 LED lights
- Includes: 3/8" drill/driver, 1/4" impact driver, (2) 12V MAX Li-Ion batteries, fast charger, (2) belt hooks and contractor bag

Model No. TLV751
Mfg. No. DCK211S2
Price/Each \$299.00

SPECIFICATIONS

Voltage: 12 V
Replacement Battery Model No.: TLV665



DEWALT

2-TOOL COMBO KITS

- M18™ 1/2" hammer drill driver with Milwaukee M18™ 1/4" hex compact impact driver
- Includes: M18™ 2607-20 1/2" hammer drill driver, M18™ 2656-20 1/4" hex compact impact driver, (2x) M18™ XC high capacity Redlithium™ batteries, charger and contractor bag

Model No. TLV047
Mfg. No. 2697-22
Price/Each \$439.00

SPECIFICATIONS

Voltage: 18 V
Chuck Size: 1/2" (hammer drill driver)
 1/4" (hex compact impact driver)
Max Torque: 550 in-lbs. (hammer drill driver)
 1400 in-lbs. (hex compact impact driver)
of Speed Settings: 2
No Load RPM Setting #1: 0-450
No Load RPM Setting #2: 0-1700
Clutch Settings: 24
Chuck Type: Keyless drill chuck
Tool Weight: 13.67 lbs.
Replacement Battery Model No.: TLZ452



Milwaukee

20 V MAX* COMBO KITS

- 20 V MAX* 1/2" hammer drill with 3-speed all-metal transmission and all-metal ratcheting chuck delivers 535 watts out of maximum performance and superior bit retention
- 20 V MAX* 1/2" impact driver features 3 LED lights with 20 second delay to provide visibility without shadows
- Includes: (2) 20 V MAX* Lithium-Ion 3.0 Ah battery packs, fast charger, 360° side handle, belt hook and contractor bag

Model No. TLV654
Mfg. No. DCK290L2
Price/Each \$489.00

SPECIFICATIONS

Voltage: 20 V
Replacement Battery Model No.: TLV656



DEWALT

M18™ FUEL™ COMBO KITS

- M18™ Fuel™ 1/2" hammer drill/driver
- M18™ Fuel™ 1/4" Hex impact driver
- The Powerstate™ brushless motor works harder and lives longer, while reducing noise and cooling more rapidly to deliver years of maintenance-free performance
- Includes: (2x) M18™ Redlithium™ XC 4.0 extended capacity battery pack, M18™ and M12™ Multi-Voltage Charger, belt clip, carrying case and side handle

Model No. TLV680
Mfg. No. 2897-22
Price/Each \$599.00

SPECIFICATIONS

Voltage: 18 V
Replacement Battery Model No.: TLV635



Milwaukee

20 V MAX XR BRUSHLESS PREMIUM HAMMERDRILL & IMPACT DRIVER COMBO

- Brushless motor delivers up to 57% more run time over brushed
- XR Li-Ion batteries with fuel gauge provide 33% more capacity
- 20 V MAX 1/2" Hammer drill 3-speed, high performance (0-2000 RPM) all-metal transmission
- 20 V MAX 1/2" Hammer drill 0-34000 BPM for fast drilling in masonry materials
- 20 V MAX 1/4" Impact driver provides 1500 in-lbs of max torque at fast 0-2800 RPM speed and 0-3200 impacts per minute
- Includes: 1/2" Hammer Drill, 1/4" Impact Driver, (2) 20 V MAX* XR High Capacity Li-Ion Batteries (4.0Ah), Fast Charger, (2) Belt Hooks, (1) Bit Holder, 360° side handle and Contractor Bag

Model No. TYD769
Mfg. No. DCK296M2
Price/Each \$599.00

SPECIFICATIONS

Voltage: 20 V
Replacement Battery Model No.: TLV657



DEWALT

18 V LXT 2-PC. COMBO KITS

- Variable 2-speed 1/2" hammer driver-drill (0-400 and 0-1500 RPM) with Makita-built 4-pole motor delivers 480 in-lbs. of max. torque
- Variable speed impact driver (0-2300 RPM and 0-3200 BPM) provides 1420 in-lbs. of max torque
- Includes: (2x) 18 V (3.0 Ah) Lithium-Ion batteries, charger and case

Model No. TLZ888
Mfg. No. LXT211
Price/Each \$492.00

SPECIFICATIONS

Voltage: 18 V
Replacement Battery Model No.: TLZ847



Makita

CORDLESS POWER TOOLS & ACCESSORIES

12V MAX LI-ION 4-TOOL COMBO KIT

- Voltage: 12 V
- Battery Type: Lithium-Ion
- What's included: (1) DCD710 3/8" drill/driver, (1) DCF815 1/4" impact driver, (1) DCS310 pivot reciprocating saw, (1) DCL510 LED work light, (2) 12V MAX* Li-Ion batteries, (1) fast charger, (2) belt hooks, (1) 4" 6 tpi wood cutting reciprocating blade, (1) Kit bag, (1) 4" 18 tpi metal cutting reciprocating blade

Model No. TLV753
Mfg. No. DCK413S2
Price/Each \$443.00

DEWALT



20 V MAX PREMIUM 4-TOOL COMBO KIT

- Voltage: 20 V
- Battery Type: Lithium-Ion
- What's Included: (1) DCD985 1/2" Hammer drill, (1) DCS380 Reciprocating Saw, (1) DCF885 1/4" Impact Driver, (1) DCL040 LED Work Light, (2) 20 V MAX* Lithium Ion 3.0 Ah Battery Packs, (1) Fast Charger, (1) 360° Side Handle, (1) Belt Hook, (1) Contractor Bag

Model No. TYD771
Mfg. No. DCK492L2
Price/Each \$866.00

DEWALT



18V LXT 4-PIECE CORDLESS COMBO KIT

- Voltage: 18 V
- Battery Type: Lithium-Ion
- What's Included: (1) 1/2" Cordless Hammer Driver Drill (DHP458Z), (1) 1/4" Cordless Impact Driver (DTD146Z), (1) 6-1/2" Cordless Circular Saw (DSS611Z), (1) Cordless Reciprocating Saw (DJR182Z), (2) 18V (4.0 Ah) Li-Ion Batteries BL1840 (196401-9), (1) Charger (DC18RC) Tool Bag (831278-2)

Model No. TYL184
Mfg. No. DLX4022M
Price/Each \$791.00

Makita



18V LXT 4-PIECE CORDLESS COMBO KIT

- Voltage: 18 V
- Battery Type: Lithium-Ion
- What's Included: (1) 1/2" Cordless Hammer Driver Drill (DHP453Z), (1) 1/4" Cordless Impact Driver (DTD146Z), (1) Cordless Reciprocating Saw (DJR182Z), (1) 6-1/2" Cordless Circular Saw (DSS611Z), (2) 18V (3.0 Ah) Li-Ion Batteries BL1830 (194205-3), (1) Charger (DC18SD), (1) Tool Bag (831278-2)

Model No. TLV098
Mfg. No. LXT430
Price/Each \$660.00

Makita



M18™ CORDLESS LITHIUM-ION 4-TOOL COMBO KIT

- Voltage: 18 V
- Battery Type: Lithium-Ion
- What's Included: (1) M18™ Compact 1/2" Hammer Drill/Driver (Bare Tool) (2607-20), (1) M18™ SAWZALL® Reciprocating Saw (Bare Tool) (2620-20), (1) M18™ 6-1/2" Circular Saw (Bare Tool) (2630-20), (1) M18™ LED Work Light (2735-20), (2) M18™ REDLITHIUM™ XC Extended Capacity Battery (48-11-1828), (1) M18™ & M12™ Multi-Voltage Charger (48-59-1812), (1) Contractor Bag

Model No. TLV046
Mfg. No. 2694-24
Price/Each \$877.00

Milwaukee



M18 FUEL™ LITHIUM-ION 4-TOOL COMBO KIT

- Voltage: 18 V
- Battery Type: Lithium-Ion
- What's Included: (1) M18 FUEL™ 1/2" Hammer Drill/Driver (Bare Tool) (2604-20), (1) M18 FUEL™ 1/4" Hex Impact Driver (Bare Tool) (2653-20), (1) M18 FUEL™ SAWZALL® Reciprocating Saw (2720-20), (1) M18™ LED Work Light (2735-20), (2) M18™ REDLITHIUM™ XC 4.0 Extended Capacity Battery Pack (48-11-1840), (1) M18™ & M12™ Multi-Voltage Charger (48-59-1812), (1) Belt Clip, (1) Contractor Bag, (1) Reciprocating Blade

Model No. TYD896
Mfg. No. 2896-24
Price/Each \$1093.00

Milwaukee



The ultimate!

210-Piece Socket Set, made of chrome vanadium steel for extra strength and durability.

aurora tools®



Model TLV362
See page 1313

CORDLESS POWER TOOLS & ACCESSORIES

20 V MAX PREMIUM 5-TOOL COMBO KIT

- Voltage: 20 V
- Battery Type: Lithium-Ion
- What's Included: (1) DCD985 1/2" Hammer Drill, (1) DCS380 Reciprocating Saw, (1) DCF885 1/4" Impact Driver, (1) DCS391 6-1/2" Circular Saw, (1) DCL040 LED Work Light, (2) 20 V MAX* Lithium Ion 3.0 Ah Battery Packs, (1) Fast Charger, (1) 360° Side Handle, (1) Belt Hook, (1) Carbide Tipped Blade, (1) Contractor Bag

Model No. TYD772
Mfg. No. DCK592L2
Price/Each \$889.00

DEWALT



18V LXT 6-PIECE CORDLESS COMBO KIT

- Voltage: 18 V
- Battery Type: Lithium-Ion
- What's Included: (1) 1/2" Cordless Hammer Driver Drill (DHP458Z), (1) 1/4" Cordless Impact Driver (DTD146Z), (1) 4-1/2" Cordless Angle Grinder (DGA452Z), (1) Cordless Reciprocating Saw (DJR182Z), (1) 6-1/2" Cordless Circular Saw (DSS611Z), (1) Cordless Jigsaw (DJV180Z), (2) 18V (4.0 Ah) Li-Ion Batteries BL1840 (196401-9), (1) Charger (DC18RC), (1) Tool Bag (831278-2)

Model No. TYL185
Mfg. No. DLX6007M
Price/Each \$925.00

Makita



M18™ CORDLESS LITHIUM-ION 6-TOOL COMBO KIT

- Voltage: 18 V
- Battery Type: Lithium-Ion
- (1) M18™ Cordless 1/2" Hammer Drill/Driver (Bare Tool) (2602-20), (1) M18™ SAWZALL® Reciprocating Saw (Bare Tool) (2620-20), (1) M18™ 6-1/2" Circular Saw (Bare Tool) (2630-20), (1) M18™ 1/4" Hex Compact Impact Driver (Bare Tool) (2650-20), (1) M18™ Cordless 4-1/2" Cut-off / Grinder (Bare Tool) (2680-20), (2) M18™ REDLITHIUM™ XC Extended Capacity Battery (48-11-1828), (1) M18™ & M12™ Multi-Voltage Charger (48-59-1812), (1) M18™ Work Light (49-24-0171), (1) Contractor Bag

Model No. TMB508
Mfg. No. 2696-26
Price/Each \$999.00

Milwaukee



M18 FUEL™ LITHIUM-ION 6-TOOL COMBO KIT

- Voltage: 18 V
- Battery Type: Lithium-Ion
- What's Included: (1) M18 FUEL™ 1/2" Hammer Drill/Driver (Bare Tool) (2604-20), (1) M18 FUEL™ 1/4" Hex Impact Driver (Bare Tool) (2653-20), (1) M18 FUEL™ SAWZALL® Reciprocating Saw (2720-20), (1) M18 FUEL™ 6-1/2" Circular Saw (Bare Tool) (2730-20), (1) M18™ LED Work Light (2735-20), (1) M18 FUEL™ 4-1/2" / 5" Grinder, Paddle Switch No-Lock (Bare Tool) (2780-20), (2) M18™ REDLITHIUM™ XC 4.0 Extended Capacity Battery Pack (48-11-1840), (1) M18™ & M12™ Multi-Voltage Charger (48-59-1812), (1) Belt Clip, (1) Circular Saw Blade, (2) Contractor Bag, (1) Reciprocating Blade, (1) Spanner Wrench

Model No. TYD897
Mfg. No. 2896-26
Price/Each \$1689.00

Milwaukee



M18™ CORDLESS LITHIUM-ION 9-TOOL COMBO KIT

- Voltage: 18 V
- Battery Type: Lithium-Ion
- What's Included: (1) M18™ Cordless 1/2" Hammer Drill/Driver (Bare Tool) (2602-20), (1) M18™ Cordless Right Angle Drill (Bare Tool) (2615-20), (1) M18™ SAWZALL® Reciprocating Saw (Bare Tool) (2620-20), (1) M18™ 6-1/2" Circular Saw (Bare Tool) (2630-20), (1) M18™ Jig Saw (Bare Tool) (2645-20), (1) M18™ 1/4" Hex Compact Impact Driver (Bare Tool) (2650-20), (1) M18™ 1/2" High-Torque Impact Wrench with Friction Ring (Bare Tool) (2663-20), (1) M18™ Cordless 4-1/2" Cut-off/Grinder (Bare Tool) (2680-20), (2) M18™ REDLITHIUM™ XC Extended Capacity Battery (48-11-1828), (1) M18™ & M12™ Multi-Voltage Charger (48-59-1812), (1) M18™ Work Light (49-24-0171)

Model No. TMB509
Mfg. No. 2696-29
Price/Each \$1794.00

Milwaukee



M18™ 15-TOOL COMBO KIT

- Voltage: 18 V
- Battery Type: Redlithium™ Lithium-Ion
- What's Included: (1) M18™ Compact Blower (Bare Tool) (0884-20), (1) M18™ Compact 1/2" Hammer Drill/Driver (Bare Tool) (2607-20), (1) M18™ Cordless 5/8" SDS Plus Rotary Hammer (Bare Tool) (2612-20), (1) M18™ Cordless Right Angle Drill (Bare Tool) (2615-20), (1) M18™ SAWZALL® Reciprocating Saw (Bare Tool) (2620-20), (1) M18™ Cordless Multi-Tool (Bare Tool) (2626-20), (1) M18™ Band Saw (Bare Tool) (2629-20), (1) M18™ 6 1/2" Circular Saw (Bare Tool) (2630-20), (1) M18™ Jig Saw (Bare Tool) (2645-20), (1) M18™ 1/4" Hex Impact Driver (Bare Tool) (2656-20), (1) M18™ 1/2" Impact Wrench with Pin Detent (Bare Tool) (2659-20), (1) M18™ 1/2" High-Torque Impact Wrench with Friction Ring (Bare Tool) (2663-20), (1) M18™ Cordless 4-1/2" Cut-off/Grinder (Bare Tool) (2680-20), (1) M18™ 5-3/8" Metal Saw (Bare Tool) (2682-20), (1) M18™ LED Work Light (2735-20), (1) M18™ Six Pack Sequential Charger (48-59-1806), (4) M18™ REDLITHIUM™ XC 4.0 Extended Capacity Battery Pack (48-11-1840)

Model No. TYD874
Mfg. No. 2695-15
Price/Each \$3473.00

Milwaukee



CORDLESS POWER TOOLS & ACCESSORIES

BATTERIES

| Model No. | Mfg. No. | Voltage | Manufacturer | Price /Each |
|-----------|------------|--|--------------|-------------|
| TF352 | 48-11-0100 | 2.4 V Battery Pack | | 35.50 |
| TLV691 | 48-11-2001 | 4 V M4™ Redlithium™ 2.0 Battery | | 59.60 |
| TLZ881 | 48-11-1830 | Battery 18 V (Single Pack) | | 189.00 |
| TFX221 | 48-11-2232 | Battery 18 V 2.4 Ah | | 277.00 |
| TYL255 | 48-11-1850 | 18 V M18™ Redlithium™ 2.0 Compact Battery Pack | | 217.00 |
| TLZ452 | 48-11-1828 | Battery 18 V Lithium High Capacity XC | | 144.00 |
| TLZ453 | 48-11-1815 | Battery 18 V Lithium 1.4 Ah XC | | 99.90 |
| TYO323 | 48-11-1852 | 18 V M18™ Redlithium™ Battery Two Pack | | 307.00 |
| TYO322 | 48-11-1841 | 18 V M18™ Redlithium™ Battery Ten Pack | | 1514.00 |
| TGX012 | 48-11-2830 | 28 V Battery Lithium-Ion | | 231.00 |
| TLV226 | 195332-9 | 12 V Lithium-Ion 1.3 Ah BL1014 - Single | | 55.90 |
| TLZ368 | 48-11-2401 | 12 V M12™ Lithium-Ion Battery | | 58.60 |
| TLV039 | 48-11-2402 | 12 V M12™ XC Battery Pack | | 99.90 |
| TLV692 | 48-11-2411 | 12 V M12™ Redlithium™ Battery 2 Pack | | 112.00 |
| TLV693 | 48-11-2412 | 12 V M12™ Redlithium™ Battery 2 Pack | | 191.00 |
| TLV694 | 48-11-2420 | 12 V M12™ Redlithium™ 2.0 Battery | | 79.90 |
| TLV695 | 48-11-2440 | 12 V M12™ Redlithium™ 4.0 Battery | | 119.00 |
| TYO324 | 48-59-2420 | 12 V M12™ Redlithium™ System Starter Kit | | 121.00 |
| TLV688 | 48-11-1811 | 18 V M18™ Battery 2 Pack | | 208.00 |
| TLV689 | 48-11-1820 | 18 V M18™ Redlithium™ 2.0 Battery | | 129.00 |
| TLV690 | 48-11-1822 | 18 V M18™ Battery 2 Pack | | 225.00 |
| TYO328 | 48-59-1813 | 18 V M18™ Redlithium™ XC System Starter Kit | | 214.00 |
| TYO329 | 48-59-1850 | 18 V M18™ Redlithium™ XC 5.0 System Starter Kit | | 267.00 |
| TNB485 | BL7010 | 7.2 V Lithium-Ion 1.0 Ah | | 61.50 |
| VI457 | 192681-5 | 12 V Battery 1220 w/clip (1.3 Ah) | | 87.80 |
| TLZ880 | 193062-6 | 14.4 V NiCd 1.3 Ah | | 99.90 |
| TLZ850 | 193139-7 | 14.4 V Ni-MH Battery 1435 (3.0 Ah) | | 99.90 |
| TDX430 | 193159-1 | 18 V 2.6 Ah Ni-MH Battery Pod Style 1834 | | 179.00 |
| TYO644 | 197198-3 | Makita® BL1850 18V Battery (5.0 Ah) | | 159.00 |
| TYL080 | 196891-6 | Makita® BL1840 18V Battery - Non Carded (4.0 Ah) | | 124.00 |
| TLZ847 | 194205-3 | 18 V Lithium-Ion Battery BL1830 (3.0 Ah) | | 114.00 |
| TLZ851 | 193140-2 | 18 V Ni-MH Battery 1835 (3.0 Ah) | | 99.90 |
| TLZ879 | 194230-4 | 18 V Lithium-Ion 3.0 Ah BL1830 - Twin | | 240.00 |
| TT909 | DW9061 | Battery Pack 9.6 V | | 80.20 |
| TT908 | DC9071 | Battery Pack 12.0 V XRP | | 98.50 |
| TT907 | DC9091 | Battery Pack 14.4 V XRP | | 109.00 |
| TT906 | DC9096 | Battery Pack 18.0 V XRP | | 137.00 |
| TGZ299 | DC9096-2 | 18 V Battery, Pack of 2 | | 199.00 |
| TNB487 | DCB080 | 8 V MAX* Lithium-Ion Battery Pack | | 31.50 |
| TLV656 | DCB203 | 20 V MAX* Compact XR Lithium-Ion Battery Pack | | 119.00 |
| TLV657 | DCB204 | 20 V MAX* Premium XR Lithium Ion Battery Pack | | 159.00 |
| TLV774 | DCB204-2 | 20 V MAX Premium XR Lithium-Ion 2-Pack | | 242.00 |

Milwaukee

Makita

DEWALT

TDX430



TYL255



TYO328



TT906



TGZ299



TLZ850



TLZ453

CHARGERS

| Model No. | Mfg. No. | Description | Manufacturer | Price /Each |
|-----------|------------|--|--------------|-------------|
| TMB526 | 48-59-2001 | M4™ Charger | | 67.20 |
| TEA462 | 48-59-0255 | Charger Universal | | 93.80 |
| TLY294 | 48-59-0280 | Charger Multi Bay Lithium-Ion/NiCd | | 281.00 |
| TEA461 | 48-59-0300 | Charger 2.4 V 120 V | | 86.40 |
| TYO327 | 48-59-1807 | M18™ & M12™ Rapid Charge Station | | 314.00 |
| TLY296 | 48-59-1812 | Charger 12 and 18 V Lithium-Ion | | 80.10 |
| TLY297 | 48-59-2401 | Charger 12 V | | 75.10 |
| TYO326 | 48-59-1204 | M12™ Four Bay Sequential Charger | | 143.00 |
| TDX433 | DC1804 | 7.2 V-18 V Charger for NiCd & Ni-MH | | 108.00 |
| TNB486 | DC185E | LXT Lithium-Ion Optimum Automotive Charger 7.2V | | 99.90 |
| TLZ901 | DC18RC | LXT Lithium-Ion 18 V Charger | | 123.00 |
| VE139 | DC012 | Charger/Radio (Charges Most 7.2 V - 18 V DeWalt Batteries) | | 247.00 |
| TYD775 | DCR015 | 12 V & 20 V MAX Worksite Charger Radio | | 288.00 |
| THZ762 | DC9000 | 36 V 1-Hour Charger | | 161.00 |
| TLZ204 | DC9310 | Heavy-Duty 7.2 V - 18 V 1-Hour Charger - Nano/NiCd | | 105.00 |
| TLZ878 | DC9319 | Heavy-Duty 7.2 V - 18 V 1-Hour Vehicle Charger - Nano/NiCd | | 154.00 |
| TLZ855 | DC9320 | Heavy-Duty 7.2 V-18 V Dual Port 1-Hour Charger - Nano/NiCd | | 158.00 |
| TLV658 | DCB101 | 12 V MAX*-20 V MAX* Lithium-Ion Battery Charger | | 106.00 |

Milwaukee

Makita

DEWALT

TLZ901



TYO327



VE139



CORDED GRINDERS & SANDERS



ANGLE GRINDERS

- Powerful 7.5 Amp, 10000 RPM motor: Provides maximum performance and durability
- Overload protection: Maximizes motor life
- Electronic clutch: Extends tool life and prevents bind-up
- Tool-free accessory change: Easily change all accessories without a wrench
- Tool-free adjustable guard: Provides quick guard installations and adjustments
- Includes: 4 1/2" grinding wheel, wheel guard, lock nut, lock nut wrench, side handle and inner flange

Model No. TGZ314
Mfg. No. 9557NB
Price/Each \$105.00

SPECIFICATIONS

Wheel Diameter: 4 1/2"
Voltage: 120 V
Amperage: 7.5
No Load RPM: 10000
Spindle Size: 5/8"
Tool Weight: 4.5 lbs.

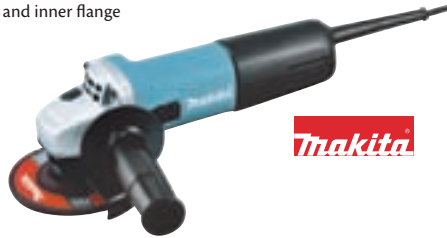

Makita

ANGLE GRINDERS W/CASE

- Labyrinth construction seals motor and bearings from contamination
- Thumb switch conveniently located for operator comfort
- Ergonomic soft grip for vibration absorption and comfortable operation
- Slim housing design for easy handling and maneuverability
- Includes: Grinding wheel, lock nut, lock nut wrench, inner flange, wheel cover assembly and plastic carrying case

Model No. TLV165
Mfg. No. GA4530K
Price/Each \$93.40

SPECIFICATIONS

Wheel Diameter: 4 1/2"
Voltage: 120 V
Amperage: 6.0
No Load RPM: 11000
Spindle Size: 5/8"
Tool Weight: 4.0 lbs.



Makita

ANGLE GRINDERS

- Compact, lightweight design
- 750 MWO motor: Powerful for daily applications
- Debris baffles: Protect internal components by deflecting damaging debris out of the airflow at the intake vents
- Multi-port exhaust: Reduces motor burn-up by efficiently venting hot air out of the grinder
- Tool free, burst resistant guard: The only grinder in its class with a tool free guard
- Compatible with multiple grinder guards and flanges
- Includes: Type 27 guard, side handle and spanner wrench

Model No. TLV064
Mfg. No. 6130-33
Price/Each \$99.90

SPECIFICATIONS

Wheel Diameter: 4 1/2"
Voltage: 120 V
Amperage: 7.0
No Load RPM: 11000
Spindle Size: 5/8"-11
Tool Weight: 3.5 lbs.



Milwaukee

ANGLE GRINDERS

- Super Joint System II reduces vibration and prevents kickback during wheel lock up
- Soft start feature gradually increases speed to eliminate start up shock
- Constant speed control maintains constant speed under heavy load
- Labyrinth construction features a series of channels to prevent penetration of dust and debris into the field and armature
- Rotatable gear housing can be positioned at every 90° for optimal positioning
- Includes: Depressed centre wheel, anti-vibration side handle, lock nut wrench, toolless wheel cover, inner flange and lock nut

Model No. TYL234
Mfg. No. GA4542C01
Price/Each \$219.00

SPECIFICATIONS

Wheel Diameter: 4 1/2"
Voltage: 120 V
Amperage: 12.0
No Load RPM: 2800-11000
Spindle Size: 5/8"-11
Tool Weight: 5.5 lbs.



Makita

ANGLE GRINDERS

- Powerful 11 Amp, 11000 RPM motor: Provides maximum performance and durability
- Overload protection: Maximizes motor life
- Electronic clutch: Extends tool life and prevents bind-up
- Tool-free accessory change: Easily change "All Accessories" without a wrench
- Tool-free adjustable guard: Provides quick guard installations and adjustments
- Trigger grip handle: Provides better control, reach and leverage
- Includes: Type 27 guard, side handle, spanner wrench, flanges

Model No. TLV734
Mfg. No. 6121-31
Price/Each \$213.00

SPECIFICATIONS

Wheel Diameter: 4 1/2"
Voltage: 120 V
Amperage: 11.0
No Load RPM: 11000
Spindle Size: 5/8"
Tool Weight: 5.4 lbs.



Milwaukee

4-1/2" ANGLE GRINDERS

- Dust Ejection System™ provides durability by ejecting damaging dust and debris particles
- Large spiral bevel gear provides long transmission life
- One-Touch™ Guard allows for 360° rotation of the guard with a single action
- Paddle switch with safety lock-off prevents accidental start up
- Includes: 2-position side handle and One-Touch™ Guard

Model No. TYL343
Mfg. No. DWE402
Price/Each \$139.00

SPECIFICATIONS

Wheel Diameter: 4 1/2"
Voltage: 120 V
Amperage: 11.0
No Load RPM: 11000
Spindle Size: 5/8"-11
Tool Weight: 4.6 lbs.



DEWALT

See pages 912 - 945 for
Abrasive Wheels & Brushes



CORDED GRINDERS & SANDERS

ANGLE GRINDERS

- Labyrinth construction seals motor and bearings from contamination
- Side handle can be mounted on left or right side of tool
- Conveniently located thumb switch for operator comfort
- Includes: 5" depressed centre wheel and side handle

Model No. TT957
Mfg. No. 9558NB
Price/Each \$130.00

SPECIFICATIONS

Wheel Diameter: 5"
Voltage: 120 V
Amperage: 7.5
No Load RPM: 10000
Spindle Size: 5/8"
Tool Weight: 4.6 lbs.



Makita

HEAVY-DUTY ANGLE GRINDERS

- High power-to-weight ratio for greater efficiency and reduced user fatigue
- External brush doors for easy servicing
- Sealed ball and roller bearings for extended motor life
- Includes: Grinding wheel, wrench, keyless adjustable guard and two position side handle

Model No. VE980
Mfg. No. DW831
Price/Each \$137.00

SPECIFICATIONS

Wheel Diameter: 5"
Voltage: 120 V
Amperage: 12.0
No Load RPM: 10000
Spindle Size: 5/8"
Tool Weight: 7.4 lbs.



DEWALT

ANGLE GRINDERS

- Labyrinth construction seals motor and bearings from contamination
- New motor with added resistance to heat and overload
- Motor winding protection to protect the wires from abrasion
- Includes: Side handle and 5" grinding wheel

Model No. TLZ330
Mfg. No. GA5010
Price/Each \$156.00

SPECIFICATIONS

Wheel Diameter: 5"
Voltage: 120 V
Amperage: 10.5
No Load RPM: 11000
Spindle Size: 5/8"
Tool Weight: 7.9 lbs.



Makita

HEAVY-DUTY HIGH PERFORMANCE GRINDERS

- Dust Ejection System™ provides increased durability by ejecting damaging dust and debris particles that enter the tool through the air intake vents
- E-Clutch® shuts the grinder off when a wheel pinch or wheel stall occurs, Power-Off® overload protection shuts the tool off before it reaches overload or burn-up
- Power Loss Reset® prevents accidental re-starts following a power disruption when the tool is left in the "on" position
- Includes: 2-position side handle, depressed centre wheel and wrench

Model No. TKZ855
Mfg. No. D28131
Price/Each \$240.00

SPECIFICATIONS

Wheel Diameter: 4 1/2" to 5"
Voltage: 120 V
Amperage: 13.0
No Load RPM: 11000
Spindle Size: 5/8"
Tool Weight: 4.6 lbs.



DEWALT

ANGLE GRINDERS

- Rear handle design for greater control
- Trigger lock
- Light weight for high production work with less fatigue
- Includes: 5" grinding wheel 24 grit and side handle

Model No. TF719
Mfg. No. 9005B
Price/Each \$156.00

SPECIFICATIONS

Wheel Diameter: 5"
Voltage: 120 V
Amperage: 10.0
No Load RPM: 10000
Spindle Size: 5/8"
Tool Weight: 6.6 lbs.



Makita

ANGLE GRINDERS W/TRIGGER GRIP

- Trigger grip handle provides better control, reach and leverage
- Debris baffles protect internal components by deflecting damaging debris out of the airflow at the intake vents
- External brush doors reduces service time by providing easy access to brushes
- Includes: Side handle, spanner wrench and type 27 guard

Model No. TLZ810
Mfg. No. 6121-31A
Price/Each \$169.00

SPECIFICATIONS

Wheel Diameter: 5"
Voltage: 120 V AC/DC
Amperage: 11.0
No Load RPM: 11000
Spindle Size: 5/8"
Tool Weight: 5.6 lbs.



Milwaukee

ANGLE GRINDERS W/LOCK-ON

- Powerful 13 Amp, 11 000 RPM motor: Provides maximum performance and durability
- Overload protection: Maximizes motor life
- Electronic clutch: Extends tool life and prevents bind-up
- Tool-free accessory change: Easily change all accessories without a wrench
- Tool-free adjustable guard: Provides quick guard installations and adjustments
- Anti-vibration side handle: Reduces vibration, increasing user comfort during extended use
- Soft start: Allows maximum control at start-up
- Includes: Type 27 guard, side handle, spanner wrench and flanges

Model No. TLV197
Mfg. No. 6117-30
Price/Each \$217.00

SPECIFICATIONS

Wheel Diameter: 5"
Voltage: 120 V
Amperage: 13.0
No Load RPM: 11000
Spindle Size: 5/8"
Tool Weight: 5.7 lbs.



Milwaukee

ZENITH
Safety Products

100% Canadian Owned Company

Safety Products for Industry

CORDED GRINDERS & SANDERS

ANGLE GRINDERS

- Slide switch with Lock-On
- Powerful 13 Amp, 11 000 RPM motor
- Electronic clutch: Extends tool life and prevents bind-up
- Tool-free accessory change: Easily change all accessories without a wrench
- Tool-free adjustable guard: Provides quick guard installations and adjustments
- Anti-vibration side handle: Reduces vibration, increasing user comfort during extended use
- Soft start: Allows maximum control at start-up
- Includes: Type 27 guard, side handle, spanner wrench and flanges

Model No. TLV735
Mfg. No. 6117-33
Price/Each \$226.00

SPECIFICATIONS

Wheel Diameter: 5"
Voltage: 120 V
Amperage: 13.0
No Load RPM: 11 000
Spindle Size: 5/8"
Tool Weight: 5.7 lbs.



ANGLE GRINDERS W/TRIGGER GRIP

- Powerful 13 Amp, 9000 RPM motor: Provides maximum performance and durability
- Overload protection: Maximizes motor life
- Electronic clutch: Extends tool life and prevents bind-up
- Tool-free accessory change: Easily change all accessories without a wrench
- Tool-free adjustable guard: Provides quick guard installations and adjustments
- Anti-vibration side handle: Reduces vibration, increasing user comfort during extended use
- Trigger grip handle: Provides better control, reach and leverage
- Includes: Lock-on, type 27 guard, side handle, spanner wrench and flanges

Model No. TLV198
Mfg. No. 6124-30
Price/Each \$249.00

SPECIFICATIONS

Wheel Diameter: 5"
Voltage: 120 V
Amperage: 13.0
No Load RPM: 9000
Spindle Size: 5/8"
Tool Weight: 5.7 lbs.



ANGLE GRINDERS W/LOCK-ON

- Powerful 13 Amp, 9000 RPM motor: Provides maximum performance and durability
- Overload protection: Maximizes motor life
- Electronic clutch: Extends tool life and prevents bind-up
- Constant Power Technology™: Maintains constant speed under load
- Tool-free accessory change: Easily change all accessories without a wrench
- Tool-free adjustable guard: Provides quick guard installations and adjustments
- Anti-vibration side handle: Reduces vibration, increasing user comfort during extended use
- Soft start: Allows maximum control at start-up
- Includes: Lock-on, type 1 guard, side handle and spanner

Model No. TLV199
Mfg. No. 6161-30
Price/Each \$229.00

SPECIFICATIONS

Wheel Diameter: 6"
Voltage: 120 V
Amperage: 12.0
No Load RPM: 9000
Spindle Size: 5/8"
Tool Weight: 6.3 lbs.



ROTO™ LARGE ANGLE GRINDERS TRIGGER GRIP W/LOCK-ON OR NON LOCK-ON

- 9-position rotating handle allows the user to adjust the main handle for better control
- Debris baffles protect internal components by deflecting damaging debris out of the airflow at the intake vents
- External brush doors - reduces service time by providing easy access to brushes
- Includes: Side handle, 7" and 9" type 27 guard and spanner wrench

Model No. TLZ821
Mfg. No. 6089-30
Price/Each \$314.00

SPECIFICATIONS

Wheel Diameter: 7" to 9"
Voltage: 120 V
Amperage: 15.0
No Load RPM: 6000
Spindle Size: 5/8"
Tool Weight: 13.7 lbs.
Trigger, Non Lock-On
Model No.: TLZ82



LARGE ANGLE GRINDERS TRIGGER GRIP W/LOCK-ON OR NON LOCK-ON

- Debris baffles protect internal components by deflecting damaging debris out of the airflow at the intake vents
- External brush doors reduce service time by providing easy access to brushes
- Soft-grip main handle provides better control and comfort
- Includes: Side handle, 7" and 9" type 27 guard and spanner wrench

Model No. TLZ819
Mfg. No. 6088-30
Price/Each \$254.00

SPECIFICATIONS

Wheel Diameter: 7" to 9"
Voltage: 120 V
Amperage: 15.0
No Load RPM: 6000
Spindle Size: 5/8"
Tool Weight: 13.7 lbs.
Trigger, Non Lock-On
Model No.: TLZ820



HEAVY-DUTY MEDIUM ANGLE GRINDERS

- High power-to-weight ratio for greater efficiency and reduced user fatigue
- External brush doors for easy servicing
- Sealed ball and roller bearing for extended motor life
- Includes: Grinding wheel and 2-position side handle

Model No. VE383
Mfg. No. DW840
Price/Each \$188.00

SPECIFICATIONS

Wheel Diameter: 7"
Voltage: 120 V
Amperage: 13.0
No Load RPM: 8000
Spindle Size: 5/8"
Tool Weight: 8.0 lbs.



CORDED GRINDERS & SANDERS

HIGH PERFORMANCE GRINDERS W/TRIGGER GRIP

- Dust Ejection System™ provides increased durability by ejecting damaging dust and debris particles that enter the tool through the air intake vents
- Jam-pot, low profile gear case provides precise gear alignment for a smoother, quieter transmission while allowing access to tight spaces
- Auto-off brushes shut the tool down when the brushes need replacing to avoid tool damage
- Includes: 2-position side handle, 5" keyless adjustable guard and 6" keyless adjustable guard

Model No. TLZ232
Mfg. No. D28065
Price/Each \$194.00

SPECIFICATIONS

Wheel Diameter: 5" or 6"
Voltage: 120 V
Amperage: 13.0
No Load RPM: 9000
Spindle Size: 5/8"
Tool Weight: 4.75 lbs.



DEWALT

HEAVY-DUTY HIGH PERFORMANCE CUT-OFF/GRINDERS

- Dual Clutch Protection™ prevents the gears from stripping and motor from burning up in a wheel pinch/stall
- Provides increased durability by ejecting damaging dust and debris particles that enter the tool through the air intake vents
- E-Clutch® shuts the grinder off when a wheel pinch or wheel stall occurs, Power-Off® overload protection shuts the tool off before it reaches overload or burn-up Power-Loss Reset™ prevents accidental re-starts following a power disruption when the tool is left in the "on" position
- Includes: 2-position side handle, depressed centre wheel and cutting wheel

Model No. TKZ854
Mfg. No. D28140
Price/Each \$273.00

SPECIFICATIONS

Wheel Diameter: 6"
Voltage: 120 V
Amperage: 13.0
No Load RPM: 9000
Spindle Size: 5/8"
Tool Weight: 4.6 lbs.



DEWALT

ANGLE GRINDERS

- Labyrinth construction seals motor and bearings from contamination
- Removable side handle can be mounted in three positions
- Low vibration rear handle with soft grip for operator comfort and control
- Includes: 7" depressed centre wheel and side handle

Model No. TLY386
Mfg. No. GA7020
Price/Each \$230.00

SPECIFICATIONS

Wheel Diameter: 7"
Voltage: 120 V
Amperage: 15.0
No Load RPM: 8500
Spindle Size: 5/8"
Tool Weight: 11.2 lbs.



Makita

ANGLE GRINDERS

- Ergonomic soft rubber grip for vibration absorption and comfortable operation
- Removable side handle can be mounted on left or right side of tool
- Rotatable gear housing can be positioned at every 90°
- Rear handle swivels 180°
- Includes: Vibration proof grip, dust cover attachment set, lock nut wrench, toolless wheel cover assembly, inner flange and lock nut

Model No. TLV144
Mfg. No. GA7031
Price/Each \$272.00

SPECIFICATIONS

Wheel Diameter: 7"
Voltage: 120 V
Amperage: 15.0
No Load RPM: 8500
Spindle Size: 5/8"
Tool Weight: 13.5 lbs.



Makita

6" ANGLE GRINDER

- Trigger Switch with No Lock-On Button
- SJS (Super Joint System) prevents kickback during wheel lock
- Electric Brake for increased operator safety
- Rotatable gear housing can be positioned at every 90° for optimal positioning
- Removable side handle can be mounted on left or right side of tool
- Ergonomic soft rubber grip design for vibration absorption and comfortable operation
- Includes: Grip, Lock Nut Wrench, Tool-less Wheel Cover, 6" Depressed Centre Wheel, Inner Flange, Lock Nut, Dust Cover Attachment

Model No. TNB127
Mfg. No. GA6020
Price/Each \$190.00

SPECIFICATIONS

Wheel Diameter: 6"
Voltage: 120 V
Amperage: 10.5 A
No Load RPM: 10000
Spindle Thread: 5/8" - 11 UNC
Net Weight: 6.6 lbs.



Makita

ANGLE GRINDERS

- Side handle can be mounted on left or right side of tool.
- AC/DC paddle switch
- Features: Labyrinth construction seals motor and bearings from contamination.
- Includes: 5" depressed centre wheel, side handle

Model No. VK529
Mfg. No. 9015DB
Price/Each \$210.00

SPECIFICATIONS

Wheel Diameter: 5"
Voltage: 120 V
Amperage: 12.5 A
No Load RPM: 10000
Spindle Size: 5/8"
Tool Weight: 7.7 lbs.



Makita

CORDED GRINDERS & SANDERS

HEAVY-DUTY 1 1/2" DIE GRINDERS

- AC/DC capacity works off welding machines and generators for increased productivity and versatility
- Convenient paddle switch with lock-on button for easy gripping
- Precision 1/4" collet with 1/8" reducing sleeve securely holds all proper accessories
- Includes: Two wrenches, 1/4" collet and 1/8" reducing sleeve

Model No. TYK731
Mfg. No. DWE4887
Price/Each \$250.00

SPECIFICATIONS

Collet Size: 1/4"
Voltage: 120 V AC/DC
Amperage: 3.0
No Load RPM: 25 000
Tool Weight: 3.25 lbs.



HEAVY-DUTY 1 5/8" DIE GRINDERS

- All ball and roller bearing construction
- Sturdy aluminum gear case
- Lightweight glass-reinforced nylon motor housing and handles
- For mounted wheels up to 1 5/8", reinforced wheels up to 2"

Model No. TF419
Mfg. No. 5192
Price/Each \$386.00

SPECIFICATIONS

Collet Size: 1/4"
Voltage: 120 V AC/DC
Amperage: 4.5
No Load RPM: 21 000
Tool Weight: 4.5 lbs.



DIE GRINDERS

- All ball and roller bearing construction
- Paddle switch operated with body grip control
- 1/4" collet standard equipment, 1/8" collet available
- Includes: 11/16" open end wrench and 1/2" open end wrench

Model No. TF420
Mfg. No. 5194
Price/Each \$397.00

SPECIFICATIONS

Collet Size: 1/4"
Voltage: 120 V AC/DC
Amperage: 4.5
No Load RPM: 21 000
Tool Weight: 4.5 lbs.



HEAVY-DUTY DIE GRINDERS

- External brush caps for easy servicing
- Collet w/ sleeve allows users to operate both 1/4" & 1/8" shaft accessories
- Includes: 2 wrenches, 1/4" collet and 1/8" reducing sleeve

Model No. TT978
Mfg. No. DW888
Price/Each \$489.00

SPECIFICATIONS

Size: 2"
Collet Size: 1/4"
Voltage: 120 V AC/DC
Amperage: 5.0
No Load RPM: 19 000
Tool Weight: 6.0 lbs.



DIE GRINDERS

- Low speed with very high torque, ideal for grinding and finishing work using brushes, flap discs and points
- Labyrinth dust proof construction prolongs tool life
- Electronic constant speed controller with soft start and variable speed dial
- Includes: Collet 1/4", two wrench and side handle set

Model No. TDU735
Mfg. No. GD0810C
Price/Each \$429.00

SPECIFICATIONS

Collet Size: 1/4"
Voltage: 120 V AC/DC
Amperage: 6.6
No Load RPM: 1800-7000
Tool Weight: 6.6 lbs.



HEAVY-DUTY 2" DIE GRINDERS

- All ball and roller bearing construction
- Ball-bearing mounted armature
- Sturdy aluminum gear case
- Helical cut alloy steel gears and shaft
- For mounted wheels up to 2", reinforced wheels up to 2"

Model No. TF421
Mfg. No. 5196
Price/Each \$499.00

SPECIFICATIONS

Collet Size: 1/4"
Voltage: 120 V AC/DC
Amperage: 11.0
No Load RPM: 14 500
Tool Weight: 7.8 lbs.



The ultimate!

210-Piece Socket Set, made of chrome vanadium steel for extra strength and durability.

aurora tools®



Model TLV362
See page 1313

CORDED SHEARS & NIBBLERS

14-GAUGE SHEARS

- Rugged aluminium alloy gear case for maximum durability
- Paddle switch for convenient one-handed operation
- Cuts radius as small as 1"
- Includes: Blade kit (upper and lower blades, screws, nuts and wrenches)

Model No. TT960
Mfg. No. DW892
Price/Each \$652.00

SPECIFICATIONS

| | |
|------------------------------|----------|
| Voltage: | 120 V |
| Amperage: | 3.0 Amp |
| Strokes per minute: | 2700 |
| Capacity in Steel: | 14 gauge |
| Capacity in Stainless Steel: | 16 gauge |
| Tool Weight: | 5.5 lbs. |



DEWALT

16-GAUGE NIBBLERS

- Die rotates 360°, easy punch and die replacement for less down time
- Built-in thickness gauge for convenience
- Lock-on sliding switch for continuous use
- Includes: Wrench, hex wrench, punch and die

Model No. TW024
Mfg. No. JN1601
Price/Each \$541.00

SPECIFICATIONS

| | |
|------------------------------|----------|
| Voltage: | 120 V |
| Amperage: | 5.0 Amp |
| Strokes per minute: | 2200 |
| Capacity in Steel: | 16 gauge |
| Capacity in Stainless Steel: | 18 gauge |
| Tool Weight: | 3.5 lbs. |



Makita

SHEARS - 16 GAUGE

- Built-in thickness gauge for operator convenience
- Sliding on/off thumb switch
- 360° rotatable shear head
- Small circumference, ergonomic motor housing for increased comfort, maneuverability and control

Model No. TNB290
Mfg. No. JS1602
Price/Each \$468.00

SPECIFICATIONS

| | |
|------------------------------|------|
| Steel cutting capacity (mm): | 1.6 |
| Stainless Steel | |
| Cutting Capacity (mm): | 1.2 |
| Minimum Cutting Radius (mm): | 30 |
| Strokes per minute: | 4000 |



Makita

16-GAUGE NIBBLERS

- Cuts up to 7 ft. per minute
- Cutter can be set in eight positions
- Paddle switch
- Includes: Allen wrench and plate wrench

Model No. TF638
Mfg. No. 6890
Price/Each \$1021.00

SPECIFICATIONS

| | |
|------------------------------|----------|
| Voltage: | 120 V |
| Amperage: | 4.0 Amp |
| Strokes per minute: | 1900 |
| Capacity in Steel: | 16 gauge |
| Capacity in Stainless Steel: | 18 gauge |
| Tool Weight: | 4.8 lbs. |



Milwaukee

18-GAUGE SHEARS

- 360° swivel head
- Trigger speed control
- Ergonomic tactile grip for optimal user comfort
- Includes: Hex wrench

Model No. THZ879
Mfg. No. 6852-20
Price/Each \$292.00

SPECIFICATIONS

| | |
|------------------------------|----------|
| Voltage: | 120 V |
| Amperage: | 6.8 Amp |
| Strokes per minute: | 2500 |
| Capacity in Steel: | 18 gauge |
| Capacity in Stainless Steel: | 20 gauge |
| Tool Weight: | 4.1 lbs. |



Milwaukee

10-GAUGE NIBBLERS

- Cuts up to 8.75 ft. per minute
- Cutter can be set in eight positions
- Toggle switch
- Includes: Allen wrench and side handle

Model No. TF637
Mfg. No. 6880
Price/Each \$1824.00

SPECIFICATIONS

| | |
|------------------------------|-------------|
| Voltage: | 120 V AC/DC |
| Amperage: | 4.0 Amp |
| Strokes per minute: | 1000 |
| Capacity in Steel: | 10 gauge |
| Capacity in Stainless Steel: | 12 gauge |
| Tool Weight: | 9.3 lbs. |



Milwaukee

For Hand Punches & Chisels
see pages 1367 - 1370



CORDED SAWS

14" CHOP SAWS

- Guide plate adjusts 45° right and left and moves to three locations for various sizes of materials
- Spark guard, adjustable depth stop and quick release vice
- Cuts a wide variety of materials including ferrous and non-ferrous metals
- Includes: One abrasive wheel, socket wrench and quick vise

Model No. VI526
Mfg. No. 2414DB
Price/Each \$239.00

SPECIFICATIONS

Amperage: 15.0
Motor Horsepower: 3.2
No Load RPM: 3800
Blade Diameter: 14"
Tool Weight: 43.0 lbs.



HEAVY-DUTY 14" CHOP SAWS

- 45° pivoting fence allows accurate angle cuts
- Spindle lock allows users to make wheel changes quickly
- Includes: 14" abrasive wheel and wrench

Model No. TGZ305
Mfg. No. D28710
Price/Each \$273.00

SPECIFICATIONS

Amperage: 15.0
Motor Horsepower: 4.0
No Load RPM: 3800
Blade Diameter: 14"
Cutting Capacity
Round: 5"
Rectangle: 4 3/4" x 5 1/3"
Tool Weight: 35.0 lbs.



HEAVY-DUTY 14" MULTI-CUTTER SAWS

- Cuts a wide variety of materials including ferrous and non-ferrous metals
- Depth of cut remains constant for carbide tipped blade
- Includes: 14" carbide tipped blade, wrench and vertical clamp

Model No. UG967
Mfg. No. DW872
Price/Each \$817.00

SPECIFICATIONS

Amperage: 15.0
Motor Horsepower: 4.0
No Load RPM: 1300
Blade Diameter: 14"
Cutting Capacity
Round: 5 3/16"
Rectangle: 4 1/2" x 6 1/2"
Tool Weight: 47.0 lbs.



14" CHOP SAWS KEYLESS BLADE CHANGE

- 45° adjustable fence allows angle cuts without using a wrench
- Soft start extends gear and motor life
- Includes: 14" abrasive wheel, fence wrench and tool free flange system

Model No. TJZ872
Mfg. No. D28715
Price/Each \$335.00

SPECIFICATIONS

Amperage: 15.0
Motor Horsepower: 5.5
No Load RPM: 4000
Blade Diameter: 14"
Cutting Capacity
Round: 5"
Rectangle: 4 1/2" x 6 1/2"
Tool Weight: 39.0 lbs.



14" ABRASIVE CHOP SAWS

- Powerful 15 Amp, 4.0 max. HP motor: Delivers maximum cutting performance in a wide variety of materials
- Large cutting capacity: Provides versatility for a wide range of cutting applications, up to 5" pipe
- 45° miter capacity with adjustable fence
- Quick adjust vise clamp: Allows clamp to be adjusted quickly when cutting different material sizes
- All ball bearing construction: Delivers maximum durability
- Includes: Vise, abrasive wheel and hex wrench

Model No. TLV202
Mfg. No. 6177-20
Price/Each \$276.00

SPECIFICATIONS

Amperage: 15.0
Motor Horsepower: 4.0
No Load RPM: 3900
Blade Diameter: 14"
Tool Weight: 40.0 lbs.



PERFORMANCE PLUS 14" CHOP SAWS

- Ball bearing induction motor
- Spark deflector for safe operation
- Quick release vise for holding workpiece, which allows cuts up to a 45° angle

Model No. WK772
Mfg. No. 8342N
Price/Each \$195.00



SPECIFICATIONS

Amperage: 15.0
No Load RPM: 3750
Blade Diameter: 14"
Max. Depth of Cut: 4"
Max. Width of Cut: 7 1/4"
Tool Weight: 45.0 lbs.



14" HAND HELD CUT-OFF MACHINES

- Downward cutting motion makes this handheld cut-off machine ideal for heavy-duty concrete and metal cutting applications
- Full 4 7/16" cut depth and downward cutting rotation
- Blade, cut-depth and guard angle adjustments are fast and easy because of the spindle lock and large footplate wing nuts
- Includes: One Allen wrench, one back flange, one flange nut and one top flange

Model No. TEA157
Mfg. No. 6185-20
Price/Each \$992.00

SPECIFICATIONS

Amperage: 15.0
Motor Horsepower: 4.8
No Load RPM: 4600
Blade Diameter: 14"
Tool Weight: 27.3 lbs.



See pages
 386 - 406 for
 Eye Protection
 Section



10" DUAL SLIDING COMPOUND MITRE SAWS W/LASER



- Sliding rail mechanism incorporating three linear ball bearings provides increased rigidity to produce precise cuts right out of the box
- Sliding fence (left side) can be adjusted outwards when bevel cutting or inwards for increased support of small or delicate materials
- Battery operated, factory calibrated Class 2 laser
- Bevel capacity of 45° left or right
- Mitre capacity of 47° left or 60° right with positive stops at 0°, 15°, 22.5°, 31.6° and 45°
- 2-stage safety switch for increased operator safety
- Includes: 10" mitre saw blade 40CT, box wrench, dust bag, vertical vise, triangle rule, 2 ea. holder

Model No. TLV225
Mfg. No. LS1018L
Price/Each \$524.00

SPECIFICATIONS

| | |
|---------------------|-----------------------|
| Amperage: | 13.0 |
| No Load RPM: | 4300 |
| Arbor: | 5/8" |
| Mitre Range: | 47° Left to 60° Right |
| Bevel Range: | 45° Left to 45° Right |
| Soft Start: | Yes |
| Tool Weight: | 43.7 lbs. |



HEAVY DUTY 12" DOUBLE BEVEL COMPOUND MITRE SAWS



- Precise mitre system and machined base fence support deliver increased cutting accuracy
- Tall sliding fences support crown mouldings up to 6 5/8" nested and base mouldings up to 6 1/2" vertically
- Adjustable stainless steel mitre detent plate
- Innovative gearbox and belt-drive design
- Includes: Carbide blade, dust bag, blade wrench

Model No. TGZ310
Mfg. No. DW716
Price/Each \$678.00

SPECIFICATIONS

| | |
|-----------------------------|---|
| Positive Mitre | |
| Detents: | 11 Positive Stops |
| Mitre Range: | 0°-50° Left, 0°-50° Right |
| Bevel Range: | 0°-48° Left, 0°-48° Right |
| Vertical Capacity: | 6 1/2" (baseboard against fence) |
| Horizontal Capacity: | 8" (10" with back fence, baseboard lying flat) |
| No Load RPM: | 3600 |
| Arbor: | 5/8" or 1" |
| Motor: | 120 VAC, 15 A |
| Tool Weight: | 44 lbs. |



12" DUAL SLIDING COMPOUND MITRE SAWS



- Dual sliding rail mechanism incorporating six linear ball bearings provides increased rigidity to produce precise, adjustment free cuts right out of the box
- 3-stage gear reduction system greatly increases capacity
- Electronic speed control maintains constant speed under heavy load
- Bevel capacity of 45° left or right with positive stops at 0°, 22.5°, 33.9° and 45°
- Mitre capacity of 52° left or 60° right with positive stops at 0°, 15°, 22.5°, 31.6° and 45°
- Re-located mitre scale enables easier viewing during operation
- Includes: 12" mitre saw blade 70CT, box wrench, dust bag, 2 ea. switch safety buttons, vertical vise, triangle rule, 2 ea. holder

Model No. TLV171
Mfg. No. LS1216
Price/Each \$849.00

SPECIFICATIONS

| | |
|---------------------|-----------------------|
| Amperage: | 15.0 |
| No Load RPM: | 3200 |
| Arbor: | 1" |
| Mitre Range: | 52° Left to 60° Right |
| Bevel Range: | 45° Left to 45° Right |
| Soft Start: | Yes |
| Tool Weight: | 58.6 lbs. |



10" DUAL SLIDING COMPOUND MITRE SAWS



- Mitre cuts 0-47° left and 0-52° right with positive stops at 15°, 22.5°, 31.6°, 45° left and right and 0°
- Electronic speed control for constant speed regardless of load
- Two pole linear ball bearing mounted sliding cutting head, adjustable pivot fence for supporting larger stock
- Includes: (1x) 10" (64 tooth) Carbide tipped saw blade, vertical vise, socket wrench #13, dust bag, triangular rule

Model No. TD896
Mfg. No. LS1016
Price/Each \$785.00

SPECIFICATIONS

| | |
|---------------------|-----------------------------|
| Amperage: | 13.0 |
| No Load RPM: | 3700 |
| Arbor: | 5/8" |
| Mitre Range: | 0°-47° Left to 0°-52° Right |
| Blade Size: | 10" Dia. |
| Tool Weight: | 46.5 lbs. |

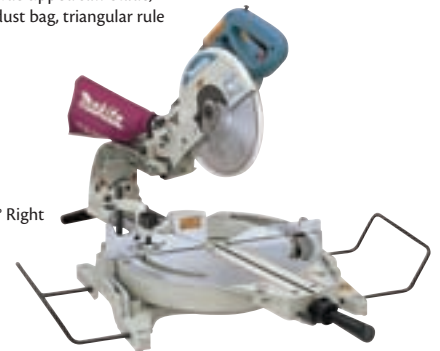

12" COMPOUND MITRE SAWS



- Positive stops at nine settings; 15°, 22.5°, 31.6°, 45°, left and right and 0° mitre cuts
- Horizontal D-handle design
- Includes: Carbide blade, socket wrench, dust bag, triangular rule, two holders and vertical vise

Model No. TDU772
Mfg. No. LS1221
Price/Each \$480.00

SPECIFICATIONS

| | |
|---------------------|-----------------------|
| Amperage: | 15.0 |
| No Load RPM: | 4000 |
| Arbor: | 1" |
| Mitre Range: | 48° Left to 48° Right |
| Bevel Range: | 45° Left to 0° Right |
| Tool Weight: | 36.4 lbs. |



10" COMPOUND MITRE SAWS



- Precision machined aluminum base
- Shaft lock for easy blade changes
- Includes: Cross-out blade, dust bag, triangular rule and socket wrench

Model No. VK963
Mfg. No. LS1040
Price/Each \$280.00

SPECIFICATIONS

| | |
|--------------------------------|--|
| Positive mitre detents: | 0°, 15°, 22.5°, 31.6° and 45° left and right |
| Mitre range: | 45° left, 52½° right |
| Bevel range: | 45° left |
| Vertical cap.: | 2 3/4" |
| Horizontal cap.: | 5 1/8" |
| No load speed: | 4600 RPM |
| Arbor: | 5/8" |
| Motor: | 120 V AC, 15.0 A |
| Weight: | 24.2 lbs. |
| Blade Size: | 10" Dia |



CORDED SAWS

12" DOUBLE BEVEL SLIDING COMPOUND MITER SAW



- Integrated XPS cross cut positioning system provides adjustment-free cut line indication for better accuracy and visibility
- Powerful 15 amp motor delivers extended power and durability
- Super efficient dust collection system captures over 75% of dust generated
- Exclusive back fence design cuts up to 2 x 16 dimensional lumber at 90° and 2 x 12 at 45°
- Adjustable stainless steel miter detent plate with 10 positive stops
- Dual horizontal steel rails with innovative clamping mechanism and linear ball bearings
- Innovative gearbox and belt-drive design increases vertical cutting capacity
- Includes: Carbide blade, blade wrench, dust bag & vertical material clamp

Model No. TLV876
Mfg. No. DWS780
Price/Each \$979.00

SPECIFICATIONS

| | |
|---------------------|------------------------|
| Voltage: | 120 |
| Amperage: | 15.0 |
| Arbor: | 5/8" or 1" |
| Mitre Range: | 50° Left and 60° Right |
| Tool Weight: | 56.0 lbs. |



12" DUAL-BEVEL SLIDING COMPOUND MITRE SAWS



- Digital angle readout provides accuracy of +/- 0.1°
- Fine adjust to dial-in precise miter angles
- Integral dust channel captures up to 75% of the dust and debris cut
- Oversized single lever bevel adjustment allows the saw to easily bevel left and right
- Includes: Carbide tipped blade, dust bag and blade wrench

Model No. TLZ332
Mfg. No. 6955-20
Price/Each \$1039.00

SPECIFICATIONS

| | |
|---------------------|-----------------------|
| Amperage: | 15.0 |
| No Load RPM: | 3200 |
| Arbor: | 5/8" or 1" |
| Mitre Range: | 55° Left to 60° Right |
| Bevel Range: | 48° Left to 48° Right |
| Soft Start: | Yes |
| Tool Weight: | 65.0 lbs. |



10" SLIDING COMPOUND MITRE SAWS W/LASER



- Twin laser guide system indicates the cut line on both sides of the blade kerf for reliable cuts every time
- Dual rail sliding system for sturdy, accurate and smooth sliding action
- Rotating table has nine positive stops at 0°, 15°, 22.5°, 30° and 45° right and left
- Includes: 2-position vertical hold down vise, retractable extension wings, dust bag and blade socket wrench

Model No. TBS757
Mfg. No. 83880
Price/Each \$271.00

SPECIFICATIONS

| | |
|---------------------|-----------------------|
| Amperage: | 15.0 |
| No Load RPM: | 5200 |
| Arbor: | 5/8" |
| Mitre Range: | 45° Left to 45° Right |
| Bevel Range: | 45° Left to 0° Right |
| Tool Weight: | 40.0 lbs. |

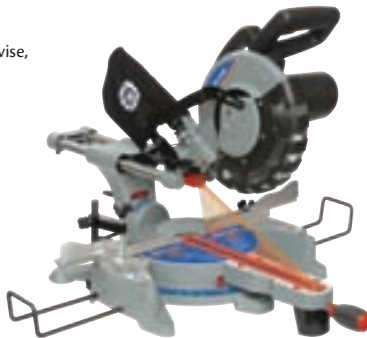

10" SLIDING DUAL COMPOUND MITRE SAWS W/LASER



- Twin laser guide system indicates the cut line on both sides of the blade kerf for reliable cuts every time
- Dual compound cuts (mitre and bevel) up to 45° left and right
- Dual rail sliding system for sturdy, accurate and smooth sliding action
- Rotating table has nine positive stops at 0°, 15°, 22.5°, 30° and 45° right and left
- Includes: 2-position vertical hold down vise, retractable extension wings, dust bag and blade socket wrench

Model No. TLV733
Mfg. No. 8385N
Price/Each \$331.00

SPECIFICATIONS

| | |
|---------------------|-----------------------|
| Amperage: | 15.0 |
| No Load RPM: | 5000 |
| Arbor: | 5/8" |
| Mitre Range: | 45° Left to 45° Right |
| Bevel Range: | 45° Left to 0° Right |
| Tool Weight: | 42.0 lbs. |



12" SINGLE-BEVEL COMPOUND MITRE SAWS



- Adjustable stainless steel miter detent plate with 11 positive stops
- Tall sliding fence supports crown molding up to 5 1/4" nested and base molding up to 6 1/2" vertically against the fence
- Designed for use with the THZ670 adjustable mitre saw laser system
- Includes: Carbide blade, extension kit, dust bag and blade wrench

Model No. TGZ308
Mfg. No. DW715
Price/Each \$511.00

SPECIFICATIONS

| | |
|---------------------|-----------------------|
| Amperage: | 15.0 |
| No Load RPM: | 4000 |
| Arbor: | 5/8" or 1" |
| Mitre Range: | 50° Left to 50° Right |
| Bevel Range: | 48° Left to 3° Right |
| Tool Weight: | 42.0 lbs. |



12" SLIDING DUAL COMPOUND MITRE SAWS W/LASER



- Twin laser guide system indicates the cut line on both sides of the blade kerf for reliable cuts every time
- Dual rail sliding system for sturdy, accurate and smooth sliding action
- Rotating table has nine positive stops at 0°, 15°, 22.5°, 30° and 45° right and left
- Includes: 2-position vertical hold down vise, retractable extension wings, dust bag and blade socket wrench

Model No. TLY298
Mfg. No. 8390N
Price/Each \$421.00

SPECIFICATIONS

| | |
|---------------------|-----------------------|
| Amperage: | 15.0 |
| No Load RPM: | 3600 |
| Arbor: | 1" |
| Mitre Range: | 45° Left to 45° Right |
| Bevel Range: | 45° Left to 45° Right |
| Tool Weight: | 55.0 lbs. |



7 1/4" CIRCULAR SAWS W/HIGH STRENGTH BASE

- High strength base will withstand a one story drop
- 56° beveling capacity with stops at 45° and 22.5°
- Electric brake stops blade after use
- Includes: Carbide tipped blade, blade wrench and contractor bag

Model No. TSW598
Mfg. No. DWE575SB
Price/Each \$222.00

SPECIFICATIONS

| | |
|-----------------------------|----------|
| Amperage: | 15.0 |
| No Load RPM: | 5200 |
| Depth of Cut at 45°: | 1 3/4" |
| Depth of Cut at 90°: | 2 1/2" |
| Tool Weight: | 8.8 lbs. |



DEWALT

8 1/4" CIRCULAR SAWS

- Rear pivot depth of cut adjustment
- 50° bevel capacity
- Electric brake stops blade after use
- Includes: Carbide tipped blade and blade wrench

Model No. TW314
Mfg. No. DW384
Price/Each \$377.00

SPECIFICATIONS

| | |
|-----------------------------|------------|
| Amperage: | 15.0 |
| No Load RPM: | 5800 |
| Depth of Cut at 45°: | 2 1/4" |
| Depth of Cut at 90°: | 2 15/16" |
| Tool Weight: | 12.75 lbs. |



DEWALT

7 1/4" CIRCULAR SAWS

- High power, maximum cutting depth of 2 1/2"
- Electric brake, twin LED lights, heavy gauge aluminium base with ruler markings
- Bevel adjustment with positive stops at 22.5° and 45°
- Includes: Guide rule, hex wrench, carbide tipped black M-Force saw blade

Model No. TLV574
Mfg. No. 500FA
Price/Each \$198.00

SPECIFICATIONS

| | |
|-----------------------------|------------------------|
| Amperage: | 15.0 |
| No Load RPM: | 5800 |
| Depth of Cut at 45°: | 1 3/4" (1 3/8" at 50°) |
| Depth of Cut at 90°: | 2 1/2" |
| Tool Weight: | 11.1 lbs. |



Makita

7 1/4" CIRCULAR SAWS

- Heavy-duty aluminum base plate for jobsite durability
- Well balanced design for better control from above or behind the saw
- Bevel capacity of 45°
- Includes: 1 ea. 7-1/4" Blade 24T, Wrench 13 (782016-4)

Model No. TF382
Mfg. No. 5007NB
Price/Each \$157.00

SPECIFICATIONS

| | |
|-----------------------------|--------|
| Amperage: | 15.0 |
| No Load RPM: | 5800 |
| Depth of Cut at 45°: | 1 3/4" |
| Depth of Cut at 90°: | 2 3/8" |



Makita

7 1/4" LEFT BLADE CIRCULAR SAWS

- Handle position can be moved to eight different positions
- Full 50° bevel capacity
- Cut visibility for right hand users with the blade on the left side
- Includes: Case, blade and hex blade wrench

Model No. TEA172
Mfg. No. 6391-21
Price/Each \$268.00

SPECIFICATIONS

| | |
|-----------------------------|-----------|
| Amperage: | 15.0 |
| No Load RPM: | 5800 |
| Depth of Cut at 45°: | 1 13/16" |
| Depth of Cut at 90°: | 2 7/16" |
| Tool Weight: | 10.4 lbs. |



Milwaukee

TILT-LOK™ 7 1/4" CIRCULAR SAWS

- Handle can be moved to different positions
- Full 50° bevel capacity
- Quick-Lok™ cord
- Includes: Blade and hex blade wrench

Model No. TEA173
Mfg. No. 6394-21
Price/Each \$325.00

SPECIFICATIONS

| | |
|-----------------------------|-----------|
| Amperage: | 15.0 |
| No Load RPM: | 5800 |
| Depth of Cut at 45°: | 1 13/16" |
| Depth of Cut at 90°: | 2 7/16" |
| Tool Weight: | 10.4 lbs. |



Milwaukee

8" METAL CUTTING SAWS

- Durable blade shield with integral chiptank deflects hot chips and sparks
- Quick-release shield latch for fast waste disposal and blade changes
- Lever's location ensures user has both hands firmly on the saw
- Includes: Case, circular saw blade and hex blade wrench

Model No. TEX280
Mfg. No. 6370-21
Price/Each \$512.00

SPECIFICATIONS

| | |
|-----------------------------|-----------|
| Amperage: | 13.0 |
| No Load RPM: | 3700 |
| Depth of Cut at 90°: | 2 9/16" |
| Tool Weight: | 13.3 lbs. |



Milwaukee

8 1/4" CIRCULAR SAWS

- High performance magnesium blade casing and base
- Bevel adjustment with positive stops at 22.5°, 45°, and 50°
- Electric brake, two built in LED lights, rubberized grips
- Includes: Carbide tipped blade, guide rule, hex wrench

Model No. TLY363
Mfg. No. 5008MGA
Price/Each \$261.00

SPECIFICATIONS

| | |
|-----------------------------|--------------------|
| Amperage: | 15.0 |
| No Load RPM: | 5200 |
| Depth of Cut at 45°: | 2 1/4" (2" at 50°) |
| Depth of Cut at 90°: | 3 |
| Tool Weight: | 11.2 lbs. |



Makita



COMPACT BAND SAWS

- 45% lighter than deep cut, 9.5 lbs. compact lightweight design for cutting overhead and in tight places
- 200-360 SFPM variable speed dial
- Drop resistant pulley guard, cast aluminum gear case, LED work light
- Includes: Blade and case

Model No. TLV040
Mfg. No. 6242-6
Price/Each \$310.00



Milwaukee

SPECIFICATIONS

| | |
|--|-----------------|
| Amperage: | 7.0 |
| Saw Surface Feet per Minute (SFPM): | 200-360 |
| Max Capacity | |
| Rectangular: | 3 1/4" x 3 1/4" |
| Round: | 3 1/4" |
| Tool Weight: | 9.5 lbs. |

DEEP CUT BAND SAWS

- Variable speeds dial and trigger and 2-finger variable speed trigger
- Adjustable material guide
- Rear blade guard - 30% thicker steel protects the guard from bending or pinching during material break-through
- Includes: Carrying case

Model No. TLV447
Mfg. No. 6232-21
Price/Each \$446.00



Milwaukee

SPECIFICATIONS

| | |
|--|-----------------|
| Amperage: | 10.5 |
| Saw Surface Feet per Minute (SFPM): | 0-420 |
| Max Capacity | |
| Rectangular: | 4 7/8" x 4 7/8" |
| Round: | 4 7/8" |
| Tool Weight: | 17.5 lbs. |

DEEP CUT PORTA-BAND® SAWS

- Dual bearing blade guide rollers increase durability in the blade support system
- Speed control knob allows to tailor the blade speed
- Blade tracking adjustment increases blade life
- Includes: Hex wrench and standard blade

Model No. TKZ842
Mfg. No. DWMT20K
Price/Each \$574.00



DEWALT

SPECIFICATIONS

| | |
|--|-------------|
| Amperage: | 10.0 |
| Saw Surface Feet per Minute (SFPM): | 100-350 |
| Max Capacity | |
| Rectangular: | 5" x 4 3/4" |
| Round: | 5" |
| Tool Weight: | 14 lbs. |

COMPACT JIG SAWS

- Keyless blade lever
- Variable speed with 4-position orbital action
- Shoe bevels 0° to 45° for bevelled cuts
- Includes: Heavy-duty case and one blade

Model No. TDX440
Mfg. No. DW317K
Price/Each \$156.00



DEWALT

SPECIFICATIONS

| | |
|----------------------------------|----------|
| Amperage: | 5.5 |
| Stroke Length: | 1" |
| Strokes per Minute (SPM): | 0-3100 |
| Tool Weight: | 6.2 lbs. |

ORBITAL JIG SAWS

- Keyless shoe adjustment with 45° in both directions and orbital action with four adjustment levels
- Quik-Lok™ blade change system and built-in dust collection port
- Tachometer feedback for constant cutting speed
- Includes: Dust shield and two blades

Model No. TKZ868
Mfg. No. 6268-21
Price/Each \$269.00



Milwaukee

SPECIFICATIONS

| | |
|----------------------------------|----------|
| Amperage: | 6.5 |
| Stroke Length: | 1" |
| Strokes per Minute (SPM): | 0-3000 |
| Tool Weight: | 6.4 lbs. |

JIG SAWS

- Uses tang style blades only
- Variable speed, vacuum port, three orbital settings plus straight cutting
- Adjustable base bevels from 0°-45° left and right
- Includes: One jig saw blade and carrying case

Model No. TLY335
Mfg. No. 4329K
Price/Each \$110.00



Makita

SPECIFICATIONS

| | |
|----------------------------------|----------|
| Amperage: | 3.9 |
| Stroke Length: | 11/16" |
| Strokes per Minute (SPM): | 500-3100 |
| Tool Weight: | 4.2 lbs. |

ORBITAL/STRAIGHT JIG SAWS

- Built-in LED job light
- Orbital change lever offers three stages and one straight cutting action, accepts tang shank blades
- Adjustable cast aluminium base; 0-45° bevel right and left
- Includes: Jig saw blade set and carrying case

Model No. TLY334
Mfg. No. 4350FCT
Price/Each \$272.00



Makita

SPECIFICATIONS

| | |
|----------------------------------|----------|
| Amperage: | 6.3 |
| Stroke Length: | 1" |
| Strokes per Minute (SPM): | 800-2800 |
| Tool Weight: | 5.3 lbs. |

HEAVY-DUTY JIG SAWS

- Keyless blade lever
- Variable speed with 4-position orbital action
- Integrated dust blower maintains visibility of cut line
- Includes: Heavy-duty case

Model No. TGZ304
Mfg. No. DW331K
Price/Each \$226.00



DEWALT

SPECIFICATIONS

| | |
|----------------------------------|----------|
| Amperage: | 6.5 |
| Stroke Length: | 1" |
| Strokes per Minute (SPM): | 500-3100 |
| Tool Weight: | 6.4 lbs. |

SAWZALL® RECIPROCATING SAWS

- Powerful 12 Amp motor: Delivers 0-3000 SPM for high performance cutting in a variety of materials
- 3/4" stroke length
- Counter weighted mechanism: Provides reduced vibration for smoother operation
- Quik-Lok™ blade clamp: Provides fast, tool-free blade changes
- Includes: Carrying case

Model No. TLV200
Mfg. No. 6509-31
Price/Each \$199.00

SPECIFICATIONS

Stroke Length: 3/4"
Amperage: 12.0
Strokes per Minute: 0-3000
Tool Weight: 7.1 lbs.



SAWZALL® RECIPROCATING SAWS

- Powerful 12 Amp motor: Delivers 0-3000 SPM for high performance cutting in a variety of materials
- 1 1/8" stroke length
- Counter weighted mechanism: Provides reduced vibration for smoother operation
- Quik-Lok™ blade clamp for fast, tool-less blade changes
- Includes: Carrying case

Model No. TLV201
Mfg. No. 6519-31
Price/Each \$195.00

SPECIFICATIONS

Stroke Length: 1 1/8"
Amperage: 12.0
Strokes per Minute: 0-3000
Tool Weight: 7.1 lbs.



VARIABLE SPEED RECIPROCATING SAWS

- Tool-less blade change system
- Blade can be inverted for near flush cutting
- Accepts standard 1/2" shank blades
- Includes: One saw blade

Model No. TFX099
Mfg. No. JR3050TY
Price/Each \$132.00

SPECIFICATIONS

Stroke Length: 1 1/8"
Amperage: 11.0
Strokes per Minute: 0-2800
Tool Weight: 7.1 lbs.



ANTI-VIBRATION RECIPROCATING SAWS

- Features anti-vibration technology (AVT)
- Orbital change lever offers three stages and one straight cutting action
- Accepts standard 1/2" shank blades
- Includes: One saw blade and carrying case

Model No. TGX675
Mfg. No. JR3070CT
Price/Each \$298.00

SPECIFICATIONS

Stroke Length: 1 1/4"
Amperage: 15.0
Strokes per Minute: 0-2800
Tool Weight: 9.5 lbs.



360° ROTATING HANDLE ORBITAL SUPER SAWZALL®

- Rotating handle locks at 45° increments
- Variable speed trigger and dial speed control
- Quik-Lok™ blade clamp, tool-less blade change and impact protection
- Includes: Carrying case and one blade

Model No. TFX209
Mfg. No. 6523-21
Price/Each \$299.00

SPECIFICATIONS

Stroke Length: 1 1/4"
Amperage: 13.0
Strokes per Minute: 0-3000
Tool Weight: 10.0 lbs.



SUPER SAWZALL®

- Maintains constant speed under load
- Variable speed trigger and dial speed control
- Quik-Lok™ blade clamp, tool-less blade change and impact protection
- Includes: Carrying case and one blade

Model No. TLY299
Mfg. No. 6538-21
Price/Each \$339.00

SPECIFICATIONS

Stroke Length: 1 1/4"
Amperage: 15.0
Strokes per Minute: 0-2800
Tool Weight: 9.8 lbs.



HEAVY-DUTY RECIPROCATING SAWS

- Orbital action
- Keyless blade clamp and keyless adjustable shoe
- Variable speed trigger and dial
- Includes: Carrying case

Model No. TGZ301
Mfg. No. DW311K
Price/Each \$269.00

SPECIFICATIONS

Stroke Length: 1 1/8"
Amperage: 13.0
Strokes per Minute: 0-2700
Tool Weight: 9.0 lbs.



See page 1201 for
 Reciprocating Saw Blades



CORDED GRINDERS & SANDERS

RANDOM ORBIT PALM SANDERS

- Fast random-orbit action for aggressive sanding
- Efficient through the pad dust collection system
- High power motor for heavy duty application
- Includes: 5" abrasive disc, dust bag and pad

Model No. TLY383
Mfg. No. BO5030
Price/Each \$99.50

SPECIFICATIONS

Sandpaper Size: 5"
Voltage: 120 V
Amperage: 3.0
Orbits per Minute: 12000
Orbit Diameter: 1/8"
Tool Weight: 2.9 lbs.



RANDOM ORBIT PALM SANDERS

- Variable speed dial: 7000-12000 orbits per minute
- Electronic soft start quickly and steadily ramps the motor up in stages
- Integrated vacuum ports fits 1 1/4" or 2 1/4" hoses
- Includes: Dust bag and carrying case

Model No. TLZ441
Mfg. No. 6021-21
Price/Each \$114.00

SPECIFICATIONS

Sandpaper Size: 5"
Voltage: 120 V
Amperage: 3.0
Orbits per Minute: 7000-12000
Orbit Diameter: 3/32"
Tool Weight: 3.3 lbs.



SHEET PALM SANDERS

- Dust bag for clean and efficient sanding with extended sandpaper life by reducing clogging
- All ball bearing construction for smooth operation, engineered to operate at low noise level with reduced vibration
- Comes with easy to use clamp lever and hook and loop pad
- Includes: Dust bag, nozzle, dust nozzle, punch plate, three sanding paper and plastic case

Model No. TLY382
Mfg. No. BO4555K
Price/Each \$76.00

SPECIFICATIONS

Sandpaper Size: 1/4 sheet
Voltage: 120 V
Amperage: 2.0
Orbits per Minute: 14000
Tool Weight: 2.4 lbs.



SHEET PALM SANDERS

- 100% ball bearing construction
- Dust sealed switch
- Dual plane counter-balanced, low vibration design reduces fatigue
- Includes: Dust bag with vacuum adapter and sandpaper punch

Model No. TGZ307
Mfg. No. D26441
Price/Each \$78.10

SPECIFICATIONS

Sandpaper Size: 1/4 sheet
Voltage: 120 V
Amperage: 2.4
Orbits per Minute: 13500
Orbit Diameter: 1/16"
Tool Weight: 3.0 lbs.



SHEET FINISHING SANDERS

- Powerful motor features increased power input and increased cooling for demanding sanding applications
- Redesigned housing reduces height creating a lower centre of gravity to improve handling and maneuverability
- Large clamping Lever for quick and easy sandpaper changes
- Large trigger switch for comfortable operation
- Rigid aluminum foot with sponge sleeves for durability and effective vibration dampening
- Ergonomic soft rubber grip design for vibration absorption and comfortable operation
- Fixed Speed
- Includes: Dust bad, Punch plate, pad, Sanding machine, (1) Sheet of abrasive paper 120G

Model No. TDU674
Mfg. No. BO3710
Price/Each \$76.00

SPECIFICATIONS

Pad Size: 3-5/8" W x 7-1/4" D
Overall Length: 10"
Cord Length: 6.6'
Sheet Size: 1/3 sheet
Voltage: 120 V
Amperage: 1.7 A
Orbits per Minute: 11000
Tool Weight: 3.5 lbs.



SHEET FINISHING SANDERS

- Variable speed dial adjusts sanding speed based on materials or applications
- Improved balancer minimizes vibration
- Paper dust bag for easy disposal of collected dust
- Improved through-the-pad dust collection system
- Large clamping lever for quick and easy sandpaper changes
- Ergonomically designed front grip and top housing for increased operator control and comfort
- Variable Speed
- Includes: Paper dust bag & holder, Hook and loop pad, Sanding machine, (1) Sheet of abrasive paper 120G

Model No. TF728
Mfg. No. BO4900V
Price/Each \$326.00

SPECIFICATIONS

Pad Size: 4-1/2" W x 9" D
Overall Length: 11-3/8"
Cord Length: 8.2'
Sheet Size: 1/2 sheet
Voltage: 120 V
Amperage: 2.9 A
Orbits per Minute: 4000 - 10000
Tool Weight: 6 lbs.



VARIABLE SPEED SANDERS

- Motor is located over platen for maximum performance and perfect balance
- Variable-speed dial is conveniently placed on the handle, allowing belt speed adjustment from 850 to 1300 SFPM
- Fingertip belt-tracking knob for quick, accurate belt adjustments, quick release belt change lever
- Includes: 100 g ceramic aluminium oxide belt and dust bag assembly

Model No. TF258
Mfg. No. 352VS
Price/Each \$299.00

SPECIFICATIONS

Belt Size: 3" x 21"
Voltage: 120 V
Amperage: 8.0
Surface Feet per Minute: 850 - 1300
Tool Weight: 10.75 lbs.



VARIABLE SPEED SANDERS

- Motor is located over platen for maximum performance and perfect balance
- Variable-speed dial is conveniently placed on the handle, allowing belt speed adjustment from 1000 to 1500 SFPM
- Fingertip belt tracking knob for quick, accurate belt adjustments, quick release belt change lever
- Includes: 100 g ceramic aluminium oxide belt and dust bag assembly

Model No. TD645
Mfg. No. 362V
Price/Each \$495.00

SPECIFICATIONS

Belt Size: 4" x 24"
Voltage: 120 V
Amperage: 12.0
Surface Feet per Minute: 1000 - 1500
Tool Weight: 14.5 lbs.



CORDED IMPACT WRENCHES

1/2" IMPACT WRENCHES

- Pin-detent system to retain sockets or adapters and a rocker switch for quick selection of forward or reverse
- Ergonomic handle with a soft cushioned grip provides a well-balanced and controllable feel to the tool
- Rocker switch for quick selection of forward and reverse

Model No. WJ082
Mfg. No. 9070-20
Price/Each \$299.00

SPECIFICATIONS

Socket Size: 1/2"
Amperage: 7.0
Torque: 300 ft.-lbs.
No Load RPM: 0-4000
No Load IPM: 2600
Tool Weight: 6.0 lbs.



Milwaukee

1/2" IMPACT WRENCHES

- Forward/Reverse rocking switch
- Soft grip handle
- Ball bearing construction for durability

Model No. TDX438
Mfg. No. DW293
Price/Each \$310.00

SPECIFICATIONS

Socket Size: 1/2"
Amperage: 7.5
Torque: 345 ft.-lbs.
No Load RPM: 2100
No Load IPM: 2700
Tool Weight: 7.0 lbs.



DEWALT

1/2" VSR IMPACT WRENCH KITS

- Pin-detent system to retain sockets or adapters and a rocker switch for quick selection of forward or reverse
- Ergonomic handle with a soft cushioned grip provides a well-balanced and controllable feel to the tool
- 10' Quik-Lok® 2-wire cord
- Includes: Case and six sockets

Model No. WJ083
Mfg. No. 9072-22
Price/Each \$399.00

SPECIFICATIONS

Socket Size: 1/2"
Amperage: 7.0
Torque: 100-300 ft.-lbs.
No Load RPM: 600-1800
No Load IPM: 1000-2600
Tool Weight: 6.0 lbs.



Milwaukee

1/2" IMPACT WRENCHES

- Heavy-duty aluminum gear housing
- Rubber inlay grip reduces vibration
- Rocker switch for forward and reverse
- Includes: Plastic carrying case

Model No. TDX437
Mfg. No. TW0350
Price/Each \$314.00

SPECIFICATIONS

Socket Size: 1/2"
Amperage: 3.5
Torque: 258.2 ft.-lbs.
No Load RPM: 2000
No Load IPM: 2000
Tool Weight: 6.4 lbs.



Makita

3/4" IMPACT WRENCHES

- Rocker switch for quick selection of forward and reverse
- Friction ring socket retention
- Light weight with balanced feel and cushioned grip

Model No. TEA202
Mfg. No. 9075-20
Price/Each \$467.00

SPECIFICATIONS

Socket Size: 3/4"
Amperage: 7.0
Torque: 380 ft.-lbs.
No Load RPM: 1750
No Load IPM: 2500
Tool Weight: 6.2 lbs.



Milwaukee

3/4" IMPACT WRENCHES

- 3/4" detent pin anvil
- Forward/reverse rocking switch
- Soft grip handle
- Ball bearing construction

Model No. TDX439
Mfg. No. DW294
Price/Each \$419.00

SPECIFICATIONS

Socket Size: 3/4"
Amperage: 7.5
Torque: 345 ft.-lbs.
No Load RPM: 2100
No Load IPM: 2700
Tool Weight: 7.0 lbs.



DEWALT

3/4" IMPACT WRENCHES

- Rocker reversing switch for one handed forward/reverse operation
- Side handle adjusts 360°
- Heavy duty rubber bumper in front
- Includes: Steel carrying case and grip assembly

Model No. TF646
Mfg. No. 6906
Price/Each \$669.00

SPECIFICATIONS

Socket Size: 3/4"
Amperage: 9.0
Torque: 433 ft.-lbs.
No Load RPM: 1500
No Load IPM: 1600
Tool Weight: 11.0 lbs.



Makita



CORDED DRILLS



1/4" MAGNUM® DRILLS

- All metal gear case and diaphragm
- Heavy-duty keyed chuck
- 360° locking side handle, 8' cord
- Includes: Side handle and chuck key holder

Model No. WJ092
Mfg. No. 0100-20
Price/Each \$268.00

SPECIFICATIONS

Chuck Size: 1/4"
Amperage: 7.0
No Load RPM: 0-2500
Chuck Type: Keyed
Tool Weight: 4.7 lbs.



3/8" MAGNUM® DRILLS

- All metal Grip-Lok™ 2-sleeve keyless chuck
- All metal gear case and diaphragm
- 360° locking side handle, 10' cord
- Includes: Side handle

Model No. WJ090
Mfg. No. 0201-20
Price/Each \$199.00

SPECIFICATIONS

Chuck Size: 3/8"
Amperage: 7.0
No Load RPM: 0-2500
Chuck Type: Keyless
Tool Weight: 4.1 lbs.



3/8" VSR DRILLS

- Helical-cut steel, heat-treated gears for increased durability
- Single-sleeve keyless chuck with spindle lock
- Two-finger trigger

Model No. TD933
Mfg. No. DW222
Price/Each \$182.00

SPECIFICATIONS

Chuck Size: 3/8"
Amperage: 6.7
No Load RPM: 0-1200
Chuck Type: Keyless
Tool Weight: 3.3 lbs.



3/8" VSR DRILLS

- Durable all ball-bearing construction
- Textured handle provides better gripping surface
- Glass-filled nylon housing is durable and impact resistant
- Includes: Kit bag

Model No. TLV567
Mfg. No. DWD110K
Price/Each \$106.00

SPECIFICATIONS

Chuck Size: 3/8"
Amperage: 8.0
No Load RPM: 0-2500
Chuck Type: Keyless
Tool Weight: 4.1 lbs.



3/8" MAGNUM® DRILLS

- Heavy-duty industrial keyless chuck
- 8' 2-wire rubber cord
- Exclusive brush cartridge system changes brushes in less than one minute
- Includes: Side handle

Model No. TT997
Mfg. No. 0233-20
Price/Each \$174.00

SPECIFICATIONS

Chuck Size: 3/8"
Amperage: 5.5
No Load RPM: 0-2800
Chuck Type: Keyless
Tool Weight: 4.0 lbs.



1/2" MAGNUM® DRILLS

- Powerful 8.0 Amp motor with variable speed control
- All metal gear case and diaphragm
- 8' 3-wire rubber cord and 360° locking side handle
- Includes: Side handle and chuck key with holder

Model No. TEA090
Mfg. No. 0299-20
Price/Each \$189.00

SPECIFICATIONS

Chuck Size: 1/2"
Amperage: 8.0
No Load RPM: 0-850
Chuck Type: Keyed
Tool Weight: 5.4 lbs.



3/8" DRILLS W/CASE

- Low decibel rating (79dB) for quieter operation
- Variable speed
- Keyless chuck for fast and easy bit installation and removal
- Includes: Plastic case

Model No. TDU647
Mfg. No. 6408K
Price/Each \$99.60

SPECIFICATIONS

Chuck Size: 3/8"
Amperage: 4.9
No Load RPM: 0-2500
Chuck Type: Keyless
Tool Weight: 3.1 lbs.



1/2" DRILLS

- Industrial aluminum gear housing for durability
- Large reversing switch and lock-on button
- Convenient belt clip
- Includes: Side handle and chuck key

Model No. TW242
Mfg. No. 6303H
Price/Each \$190.00

SPECIFICATIONS

Chuck Size: 1/2"
Amperage: 6.5
No Load RPM: 0-850
Chuck Type: Keyed
Tool Weight: 4.8 lbs.



1/2" MAGNUM® DRILLS

- Trigger speed control with reversing
- Heavy-duty industrial chuck and 8' 3-wire cord
- Exclusive brush cartridge system changes brushes in less than one minute
- Includes: Side handle and chuck key with holder

Model No. TF016
Mfg. No. 0234-6
Price/Each \$262.00

SPECIFICATIONS

Chuck Size: 1/2"
Amperage: 5.5
No Load RPM: 0-850
Chuck Type: Keyed
Tool Weight: 4.8 lbs.



Milwaukee

1/2" VSR DRILLS

- Single-sleeve keyless chuck with spindle lock
- Triple gear reduction provides increased torque
- Helical-cut steel, heat-treated gears for increased durability
- Includes: 360° locking side handle

Model No. TD936
Mfg. No. DW246
Price/Each \$275.00

SPECIFICATIONS

Chuck Size: 1/2"
Amperage: 7.8
No Load RPM: 0-600
Chuck Type: Keyless
Tool Weight: 4.4 lbs.



DEWALT

1/2" MAGNUM® DRILLS

- Powerful 8.0 Amp motor with variable speed control
- All metal ratcheting chuck with carbide jaws has the highest grip torque on bits
- Ergonomic tactile grip and two finger trigger
- Includes: Side handle

Model No. TEA092
Mfg. No. 0302-20
Price/Each \$229.00

SPECIFICATIONS

Chuck Size: 1/2"
Amperage: 8.0
No Load RPM: 0-850
Chuck Type: Keyless
Tool Weight: 5.6 lbs.



Milwaukee

1/2" VSR DRILLS

- Triple gear reduction provides increased torque
- Metal gear housing for jobsite durability
- Helical-cut steel, heat-treated gears for increased durability
- Includes: 360° side handle and chuck key with holder

Model No. TD935
Mfg. No. DW245
Price/Each \$251.00

SPECIFICATIONS

Chuck Size: 1/2"
Amperage: 7.8
No Load RPM: 0-600
Chuck Type: Keyed
Tool Weight: 4.4 lbs.



DEWALT

1/2" COMPACT DRILLS

- Made for two handed operation
- Rear mounted assist spade handle
- Heat treated gears are helical-cut for quiet performance
- Includes: Pipe handle

Model No. TF092
Mfg. No. 1660-6
Price/Each \$404.00

SPECIFICATIONS

Chuck Size: 1/2"
Amperage: 7.0
No Load RPM: 0-500
Chuck Type: Keyed
Tool Weight: 11.4 lbs.



Milwaukee

1/2" SPADE HANDLE DRILLS

- Variable speed reversing switch avoids air bubbles when mixing mud and offers greater control
- 0-550 RPM provides increased torque for drilling and mud mixing
- Soft grip handle provides comfort and ergonomics
- Includes: 3-position side handle, chuck key with holder and 2-position rear spade handle

Model No. TKZ843
Mfg. No. DW130V
Price/Each \$224.00

SPECIFICATIONS

Chuck Size: 1/2"
Amperage: 9.0
No Load RPM: 0-550
Chuck Type: Keyed
Tool Weight: 7.5 lbs.



DEWALT

3/4" LARGE DRILLS

- Heavy duty aluminum alloy housing
- Powerful reversing motor
- Drive shafts run smoothly on pre-lubricated ball-bearings
- Includes: Pipe handle

Model No. TF103
Mfg. No. 1854-1
Price/Each \$999.00

SPECIFICATIONS

Chuck Size: 3/4"
Amperage: 10.0
No Load RPM: 0-350
Chuck Type: Keyed
Tool Weight: 19.0 lbs.



Milwaukee

1/2" DRILLS W/HANDLE

- Rocker switch for easy one handed reversing
- Double gear reduction for added torque
- Rear handle rotates 360°
- Includes: Side handle and chuck key

Model No. TF481
Mfg. No. 6013BR
Price/Each \$219.00

SPECIFICATIONS

Chuck Size: 1/2"
Amperage: 6.3
No Load RPM: 0-550
Chuck Type: Keyed
Tool Weight: 6.2 lbs.



Makita

CORDED DRILLS

1/2" D-HANDLE DRILLS

- Heat treated metal gears for quiet performance
- Trigger speed control: 0-500 RPM, reversing
- Can be used with our right angle drive attachment to increase versatility
- Includes: Side handle and chuck key with holder

Model No. TF058
Mfg. No. 1107-6
Price/Each \$387.00

SPECIFICATIONS

Chuck Size: 1/2"
Amperage: 7.0
No Load RPM: 0-500
Chuck Type: Keyed
Tool Weight: 6.8 lbs.



Milwaukee

1/2" D-HANDLE RIGHT ANGLE DRILLS

- Heat treated metal gears for quiet performance
- All ball and roller bearings
- Head and handle swivel 360°
- Includes: right angle adaptor assembly, side handle, 9/16" open end wrench, 3/16" socket wrench and carrying case

Model No. TF198
Mfg. No. 3102-6
Price/Each \$439.00

SPECIFICATIONS

Chuck Size: 1/2"
Amperage: 7.0
No Load RPM: 335/500/750
Chuck Type: Keyed
Tool Weight: 10.3 lbs.



Milwaukee

1/2" RIGHT ANGLE DRILLS

- Three speed ranges. 400/900 RPM for right angle drilling and 600 RPM for straight
- Die-cast metal gear housing for jobsite durability
- 5-position side handle
- Includes: Chuck key with holder, 5-position handle, Allen wrench and heavy-duty kit box

Model No. TW249
Mfg. No. DW120K
Price/Each \$495.00

SPECIFICATIONS

Chuck Size: 1/2"
Amperage: 7.0
No Load RPM: 400/600/900
Chuck Type: Keyed
Tool Weight: 9.75 lbs.

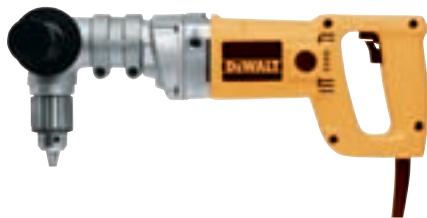

DEWALT

3/8" ANGLE DRILLS

- Built-in LED job light and reduced head height (2 5/8")
- Compact (10 5/8" length) design for close quarters
- Paddle switch with speed limiting dial
- Includes: Grip and chuck key with holder

Model No. TF811
Mfg. No. DA3010F
Price/Each \$288.00

SPECIFICATIONS

Chuck Size: 3/8"
Amperage: 4.0
No Load RPM: 0-2400
Chuck Type: Keyed
Tool Weight: 3.1 lbs.



Makita

1/2" SUPER HAWG™

- Two operating speeds of 1750 and 450 RPM with a clutch in the low gear range
- Grip Roto-Lok® handle features 3 positions with 90° left-right rotation
- Includes: Side handle

Model No. TEA124
Mfg. No. 1680-21
Price/Each \$642.00

SPECIFICATIONS

Chuck Size: 1/2"
Amperage: 13.0
No Load RPM: 450/1750
Chuck Type: Keyed
Tool Weight: 14.7 lbs.



Milwaukee

3/8" CLOSE QUARTER ANGLE DRILLS

- Angled chuck for reaching close quarters
- Large paddle trigger
- Angled cord exit and metal framed gear train
- Includes: Chuck key and holder

Model No. TLZ155
Mfg. No. 0370-20
Price/Each \$199.00

SPECIFICATIONS

Chuck Size: 3/8"
Amperage: 3.5
No Load RPM: 0-1300
Chuck Type: Keyed
Tool Weight: 3.9 lbs.



Milwaukee

1/2" DUAL RANGE IMPACT DRILLS

- Thumb wheel for preselecting of speed
- Die cast aluminum gear housing
- Two-speed gear unit
- Clockwise and anticlockwise rotation
- Auto-stop carbon brushes
- Includes: Chuck key, long side handle, depth guide and carrying case

Model No. TKZ001
Mfg. No. SEB751
Price/Each \$450.00

SPECIFICATIONS

Chuck Size: 1/2"
Amperage: 6.2
No Load RPM: 0-1000/0-3000
No Load BPM: 0-57000
Chuck Type: Keyed
Tool Weight: 5.2 lbs.



metabo

1/2" VSR DUAL RANGE HAMMER DRILLS

- High/low speed for high speed drilling or high torque applications
- 8.2 Amp motor provides high performance and overload protection
- 360° side handle with depth rod offers greater control
- Includes: 360° side handle, depth rod and chuck key with holder

Model No. TKZ841
Mfg. No. DW520K
Price/Each \$254.00

SPECIFICATIONS

Chuck Size: 1/2"
Amperage: 10
No Load RPM: 0-1200/0-3500
No Load BPM: 0-56000
Chuck Type: Keyed
Tool Weight: 6.0 lbs.



DEWALT

1/2" DUAL RANGE HAMMER DRILLS W/CARRYING CASE

- 1/2" capacity; 7.5 Amp motor
- Trigger-lock, trigger speed control in two ranges: 0-1350 RPM, 0-22 000 BPM; 0-2500 RPM, 0-40 000 BPM; reversing
- Hammer with rotation or rotation only
- Self-stop brush system
- Includes: Depth gauge, side handle, chuck key and case

Model No. TEA141
Mfg. No. 5378-21
Price/Each \$239.00

SPECIFICATIONS

Chuck Size: 1/2"
Amperage: 7.5
No Load RPM: 0-1350/0-2500
No Load BPM: 0-20000/0-40000
Chuck Type: Keyed
Tool Weight: 6.0 lbs.



Milwaukee

1/2" VSR HAMMER DRILLS

- Lightweight design for less user fatigue
- Dual mode hammer drill/drill for wood, steel or masonry applications
- Variable speed allows for precise hole placement on work surface
- Includes: 360° side handle, depth rod and chuck key with holder

Model No. TSW576
Mfg. No. DW511
Price/Each \$159.00

SPECIFICATIONS

Chuck Size: 1/2"
Amperage: 6.7
No Load RPM: 0-2700
No Load BPM: 0-46000
Chuck Type: Keyed
Tool Weight: 4.3 lbs.



DEWALT

1/2" DUAL RANGE HAMMER DRILLS

- Trigger speed control in two ranges: 0-1350 RPM, 0-22 000 BPM, 0-2500 RPM, 0-40 000 BPM, reversing
- A removable side handle assists in setting the depth rod for pre-set hole drilling
- Hammer with rotation or rotation only
- Includes: Depth gauge, side handle and chuck key

Model No. TT928
Mfg. No. 5378-20
Price/Each \$229.00

SPECIFICATIONS

Chuck Size: 1/2"
Amperage: 7.5
No Load RPM: 0-1350/0-2500
No Load BPM: 0-20000/0-40000
Chuck Type: Keyed
Tool Weight: 6.0 lbs.



Milwaukee

1/2" VSR DUAL RANGE HAMMER DRILLS

- High/low speed for high speed drilling or high torque applications
- Lightweight design for less user fatigue
- 360° side handle with depth rod offers greater control
- Includes: Side handle, chuck key and plastic carrying case

Model No. TD944
Mfg. No. DW505K
Price/Each \$212.00

SPECIFICATIONS

Chuck Size: 1/2"
Amperage: 7.8
No Load RPM: 0-1100/0-2700
No Load BPM: 0-19000/0-46000
Chuck Type: Keyed
Tool Weight: 4.8 lbs.



DEWALT

1/2" HAMMER DRILLS WITH CARRYING CASE

- Anti-vibration system (AVS): Delivers maximum comfort by minimizing vibration
- 2-mode operation: Hammer drill/drill for maximum versatility in wood, metal, and concrete
- 2-speed gear box: Allows the user to select the correct drilling speed for the material and accessory
- 360° side handle with depth gauge
- Includes: Depth gauge, removable side handle and carrying case

Model No. TLZ439
Mfg. No. 5380-21
Price/Each \$254.00

SPECIFICATIONS

Chuck Size: 1/2"
Amperage: 9.0
No Load RPM: 0-1500/0-3500
No Load BPM: 0-24000/0-56000
Chuck Type: Keyed
Tool Weight: 7.3 lbs.



Milwaukee

1" THREE MODE SDS ROTARY HAMMERS

- Three modes of operation: hammer-drill, drill only, and chipping
- Variable speed allows for precise hole placement on work surface
- Factory set clutch reduces sudden, high torque reactions if bit jams
- Includes: 360° side handle

Model No. TKZ858
Mfg. No. D25123K
Price/Each \$350.00

SPECIFICATIONS

Solid Bit Capacity: 1"
Amperage: 8.0
No Load RPM: 0-1150
No Load BPM: 0-4300
Impact Energy: 2.5 ft.-lbs.
Tool Weight: 5.7 lbs.



DEWALT

CORDED DRILLS

5/8" SDS+ ROTARY HAMMERS

- Lightweight, 4.6 lbs, compact, 10 1/4" length: Allows for work in tight spaces
- Mechanical clutch: Protects tool when bit binds up
- AVS - Anti vibration system: Delivers maximum comfort by minimizing vibration
- 2-mode operation: Rotary hammer and rotation only for maximum versatility
- Includes: Side handle, depth rod and carrying case

Model No. TLV203
Mfg. No. 5263-21
Price/Each \$289.00

SPECIFICATIONS

Solid Bit Capacity: 5/8"
Amperage: 5.5
No Load RPM: 0-3700
No Load BPM: 0-4400
Impact Energy: 1.5 ft.-lbs.



Milwaukee

7/8" SDS PLUS ROTARY HAMMERS

- Three modes of operation: Rotary hammer, hammer only and rotation only
- Mechanical clutch: Protects the motor when the bit binds
- Variable position chisel stop: Allows material to be adjusted, regardless of orientation
- Includes: Depth gauge, side handle and carrying case

Model No. TLV204
Mfg. No. 5262-21
Price/Each \$299.00

SPECIFICATIONS

Solid Bit Capacity: 7/8"
Amperage: 7.0
No Load RPM: 0-1500
No Load BPM: 0-5625
Impact Energy: 1.8 ft.-lbs.
Tool Weight: 5.8 lbs.



Milwaukee

SDS MAX ROTARY HAMMERS

- Thin wall core bit capacity: 4"
- Drilling mode: 2-mode: Rotary hammer and hammer only
- Heavy-duty 5.5 ft.-lbs. of impact energy for solid performance
- Constant Power Technology ensures consistent drilling power for the toughest applications
- A 12-position chipping adjustment lets you maintain the optimum hammer position while chipping in any orientation
- A mechanical clutch protects the motor when the bit binds
- Two-mode operation offers maximum versatility regardless of the application
- Tool comes with a side handle and carrying case

Model No. TMB675
Mfg. No. 5317-21
Price/Each \$719.00

SPECIFICATIONS

Solid Bit Capacity: 1 9/16"
Amperage: 10.5
No Load RPM: 0-450
No Load BPM: 0-3000
Impact Energy: 5.5 ft.-lbs.
Tool Weight: 15 lbs.



Milwaukee

1 3/4" SDS-MAX ROTARY HAMMERS

- Clutch reduce the tools reaction to embedded steel when bits "lock-up" in operation
- Electronic Variable Speed allows the user to control the speed of drilling and chipping
- Includes: 360° side handle, depth rod and heavy-duty kit box

Model No. TSW682
Mfg. No. D25602K
Price/Each \$1117.00

SPECIFICATIONS

Solid Bit Capacity: 1 3/4"
Amperage: 11.5
No Load RPM: 140-280
No Load BPM: 1330-2660
Impact Energy: 8 ft.-lbs.
Tool Weight: 13.4 lbs.



DEWALT

SDS PLUS ROTARY HAMMER KITS

- Thin Wall Core Bit Capacity: 3"
- Vibration: 10.6 m/s²
- Drilling mode: 3-mode: Rotary hammer, hammer only, rotation only
- Get up to 85% faster drilling and 85% harder hitting while reducing vibration
- Equipped with an all metal gear case and mechanical clutch to provide maximum durability
- Powerful and lightweight
- Kit includes a side handle, depth rod and carrying case

Model No. TYO341
Mfg. No. 5268-21
Price/Each \$589.00

SPECIFICATIONS

Solid Bit Capacity: 1 1/8"
Amperage: 8
No Load RPM: 0-1500
No Load BPM: 0-5500
Impact Energy: 3.6 ft.-lbs.
Tool Weight: 7.5 lbs.



Milwaukee

1 9/16" SPLINE ROTARY HAMMERS

- Electronic Variable Speed allows the user to control the speed of drilling and chipping
- Spline tool holder is compatible with all spline drive bits
- Includes: 360° side handle, depth rod and heavy-duty kit box

Model No. TSW672
Mfg. No. D25553K
Price/Each \$974.00

SPECIFICATIONS

Solid Bit Capacity: 3/8" x 1 1/4"
Amperage: 12.0
No Load RPM: 490
No Load BPM: 3300
Impact Energy: 7.3 ft.-lbs.
Tool Weight: 14.0 lbs.



DEWALT

POWER SCRAPERS

- Quick change bit retainer for easy changes
- Motor has auto shut-off feature when brushes must be replaced
- Factory grease packed for approximately 200 hours of maintenance free operation
- Includes: 1 3/16" and 2" scaling chisels, bull point, dust cover and plastic carrying case

Model No. TF850
Mfg. No. HK1820
Price/Each \$656.00

SPECIFICATIONS

Amperage: 5
No Load BPM: 0-3200
Impact Energy: 2.9 ft.-lbs.
Tool Weight: 7.5 lbs.



Makita

1 3/4" SDS-MAX ROTARY HAMMERS

- AVS: anti vibration system that actively reduces user vibration
- 2-speed impact mode: Low reduces speed (350 RPM) and beats per minute (2200 BPM) for light materials
- Constant power technology maintains drilling speed and power when the tool is under load mechanical clutch and protects the gears and provides added control
- Includes: Side handle, depth rod and carrying case

Model No. TLZ834
Mfg. No. 5426-21
Price/Each \$1089.00

SPECIFICATIONS

Solid Bit Capacity: 1 3/4"
Amperage: 14.0
No Load RPM: 0-350
No Load BPM: 0-2200
Impact Energy: 8.8 ft.-lbs.



Milwaukee

2" SDS MAX ROTARY HAMMERS

- Heavy-duty robust construction, digs and drills under the most demanding jobsite conditions
- Three handle positions offer greater user comfort
- System of vibration absorption/reduction reduces operator fatigue
- The side handle can be attached to the rear switch handle which minimizes bending over
- Includes: Side handle and carrying case

Model No. TFX202
Mfg. No. 5342-21
Price/Each \$1599.00

SPECIFICATIONS

Solid Bit Capacity: 2"
Amperage: 15.0
No Load RPM: 125-250
No Load BPM: 975-1950
Impact Energy: 19.9 ft.-lbs.
Tool Weight: 27.75 lbs.



Milwaukee

2" SPLINE DRIVE ROTARY HAMMERS

- Large electric hammer used for drilling large holes or breaking concrete and asphalt
- System of vibration absorption/reduction reduces operator fatigue
- The side handle can be attached to the rear switch handle which minimizes bending over
- Includes: Side handle and carrying case

Model No. TFX201
Mfg. No. 5340-21
Price/Each \$1645.00

SPECIFICATIONS

Solid Bit Capacity: 2"
Amperage: 15.0
No Load RPM: 125-250
No Load BPM: 975-1950
Impact Energy: 19.9 ft.-lbs.
Tool Weight: 26.2 lbs.



Milwaukee

DRYWALL SCREW GUNS

- Variable speed control
- Ramp-off depth locator for easy depth adjustments
- Ergonomic tactile grip and two finger trigger for user comfort and balance
- Includes: Belt clip

Model No. WJ087
Mfg. No. 6742-20
Price/Each \$162.00

SPECIFICATIONS

Amperage: 6.5
No Load RPM: 0-4000
Tool Weight: 3.5 lbs.



Milwaukee

DEMOLITION HAMMERS W/ANTI-VIBRATION

- Anti-Vibration Technology enabled to reduce fatigue and injury due to exposure to vibration
- Extra long auto cut off carbon brushes provides reduced maintenance
- Electronic speed and variable control gives efficient hammering at the desired speed
- Includes: Side handle, bull point and carrying case

Model No. TLY750
Mfg. No. HM1214C
Price/Each \$1379.00

SPECIFICATIONS

Amperage: 14.0
BPM: 950-1900
Impact Energy: 18.95 ft.-lbs.
Tool Weight: 27.1 lbs.



Makita

HEAVY-DUTY DRYWALL SCREW GUNS

- Variable speed, reversible
- Externally adjustable 6 stage torque-sensitive clutch mechanism
- Adjustable depth sensitive control mechanism
- 5/16" magnetic nutsetter included

Model No. TDU641
Mfg. No. FS2701
Price/Each \$158.00

SPECIFICATIONS

Amperage: 6.0
No Load RPM: 0-2500
Tool Weight: 3.5 lbs.



Makita

PAVEMENT BREAKERS

- Active Vibration Control reduces user fatigue and increases comfort and productivity
- Electronic soft start increases productivity by reducing bit walking
- Rubber coated handles provide greater comfort and control

Model No. TLY751
Mfg. No. D25980
Price/Each \$2650.00

SPECIFICATIONS

Amperage: 15.0
BPM: 900
Impact Energy: 61 ft.-lbs.
Tool Weight: 68.3 lbs.



DeWALT

HIGH SPEED VSR DRYWALL SCREW GUNS

- Depth-sensitive nosepiece for consistent fastener depth
- Two-finger trigger
- Helical-cut, heat-treated gears for durability

Model No. TSW573
Mfg. No. DW255
Price/Each \$135.00

SPECIFICATIONS

Amperage: 6.0
No Load RPM: 0-5300
Tool Weight: 2.9 lbs.



DeWALT

PORTABLE DRILL PRESSES

COMPACT ELECTROMAGNETIC DRILL PRESSES

- Two-coil magnet provides 2300 lbs. of dead lift force on 1 in. thick steel
- Light weight with carrying handle
- Feed handle can be relocated to the opposite side without tools
- Includes: Lubricant bottle, nylon safety strap and two hex wrenches

Model No. WK773
Mfg. No. 4270-20
Price/Each \$1599.00

SPECIFICATIONS

| | |
|-----------------------|-----------|
| Amperage: | 9.0 |
| Drill Capacity: | 1/2" |
| No Load RPM: | 450 |
| Drill Point Pressure: | 750 lbs. |
| Drill Travel: | 6.6" |
| Tool Weight: | 26.5 lbs. |

Milwaukee



1/2" ADJUSTABLE POSITION ELECTROMAGNETIC DRILL PRESSES

- Solid state electronic switching
- Feedback speed control
- Line Lock-Out prevents tool from operating should voltage be restored to an interrupted line

Model No. TF318
Mfg. No. 4204-1
Price/Each \$2262.00

SPECIFICATIONS

| | |
|-----------------------|----------------|
| Amperage: | 7.2 |
| Drill Capacity: | 1/2" |
| No Load RPM: | 600 |
| Drill Point Pressure: | 1610/1650 lbs. |
| Drill Travel: | 9" |
| Tool Weight: | 57.0 lbs. |

Milwaukee



3/4" FIXED POSITION ELECTROMAGNETIC DRILL PRESSES

- Solid state electronic switching
- Feedback speed control
- Line Lock-Out prevents tool from operating should voltage be restored to an interrupted line

Model No. TF322
Mfg. No. 4210-1
Price/Each \$2321.00

SPECIFICATIONS

| | |
|-----------------------|----------------|
| Amperage: | 12.5 |
| Drill Capacity: | 3/4" |
| No Load RPM: | 350 |
| Drill Point Pressure: | 1630/1670 lbs. |
| Drill Travel: | 9" |
| Tool Weight: | 62.0 lbs. |

Milwaukee



3/4" ADJUSTABLE POSITION ELECTROMAGNETIC DRILL PRESSES

- Solid state electronic switching
- Feedback speed control
- Line Lock-Out prevents tool from operating should voltage be restored to an interrupted line

Model No. TF319
Mfg. No. 4206-1
Price/Each \$2630.00

SPECIFICATIONS

| | |
|-----------------------|----------------|
| Amperage: | 12.5 |
| Drill Capacity: | 3/4" |
| No Load RPM: | 350 |
| Drill Point Pressure: | 1630/1670 lbs. |
| Drill Travel: | 11" |
| Tool Weight: | 70.0 lbs. |

Milwaukee



1 1/4" ADJUSTABLE POSITION ELECTROMAGNETIC DRILL PRESSES

- Solid state electronic switching
- Feedback speed control
- Line Lock-Out prevents tool from operating should voltage be restored to an interrupted line

Model No. TF320
Mfg. No. 4208-1
Price/Each \$2699.00

SPECIFICATIONS

| | |
|-----------------------|----------------|
| Amperage: | 12.5 |
| Drill Capacity: | 1 1/4" |
| No Load RPM: | 500/250 |
| Drill Point Pressure: | 1530/1600 lbs. |
| Drill Travel: | 11" |
| Tool Weight: | 72.0 lbs. |

Milwaukee



1 1/4" ADJUSTABLE POSITION ELECTROMAGNETIC DRILL PRESSES

- Solid state electronic switching
- Feedback speed control
- Line Lock-Out prevents tool from operating should voltage be restored to an interrupted line

Model No. TEA125
Mfg. No. 4209-1
Price/Each \$2699.00

SPECIFICATIONS

| | |
|-----------------------|----------------|
| Amperage: | 12.5 |
| Drill Capacity: | 1 1/4" |
| No Load RPM: | 750/375 |
| Drill Point Pressure: | 1530/1600 lbs. |
| Drill Travel: | 11" |
| Tool Weight: | 72.0 lbs. |

Milwaukee



3/4" MOTOR FOR ELECTROMAGNETIC DRILL PRESSES

- Dual mount gear case
- Reverse mount for tight quarter drilling
- Taps up to 1"-14 threaded hole
- Develops up to 1670 pounds of drill point pressure with a 1" steel plate

Model No. TF328
Mfg. No. 4262-1
Price/Each \$996.00



SPECIFICATIONS

| | |
|------------------------------|----------------|
| Amperage: | 11.5 |
| Drill Capacity: | 3/4" |
| No Load RPM: | 350 |
| Drill Point Pressure: | 1630/1670 lbs. |
| Tool Weight: | 21.0 lbs. |

DIAMOND CORING RIGS W/SMALL BASE, VAC-U-RIG® KIT, METER BOX & MOTOR

- Cast aluminum base with four levelling screws for adjustment
- Durable precision-ground 2 1/2" steel column, 43 1/2" high
- Rear mounted rack and pinion feed
- Includes: 4096 diamond coring motor

Model No. VH886
Mfg. No. 4115-22
Price/Each \$3535.00



SPECIFICATIONS

| | |
|---------------------|------------|
| Height: | 43 1/2" |
| Wheels: | Yes |
| Vac Base: | Yes |
| Vac Pump: | Yes |
| Motor: | Yes |
| Meter Box: | Yes |
| Tool Weight: | 111.5 lbs. |

DIAMOND CORING LARGE BASE STANDS

- Cast aluminum base with four levelling screws for adjustment
- Durable precision-ground 2 1/2" steel column, 43 1/2" high
- Rear mounted rack and pinion feed
- Includes: Jackscrew for ceiling and back wall bracing

Model No. TEA017
Mfg. No. 4120
Price/Each \$1158.00



SPECIFICATIONS

| | |
|---------------------|-----------|
| Height: | 43 1/2" |
| Wheels: | Yes |
| Vac Base: | Yes |
| Vac Pump: | No |
| Motor: | No |
| Meter Box: | No |
| Tool Weight: | 67.0 lbs. |

DIAMOND CORING RIGS W/SMALL BASE, VAC-U-RIG® KIT, METER BOX & MOTOR

- Cast aluminum base with four levelling screws for adjustment
- Durable precision-ground 2 1/2" steel column, 43 1/2" high
- Rear mounted rack and pinion feed
- Includes: 4096 diamond coring motor

Model No. VH889
Mfg. No. 4120-22
Price/Each \$3638.00



SPECIFICATIONS

| | |
|---------------------|------------|
| Height: | 43 1/2" |
| Wheels: | Yes |
| Vac Base: | Yes |
| Vac Pump: | Yes |
| Motor: | Yes |
| Meter Box: | Yes |
| Tool Weight: | 115.3 lbs. |

SEE PAGES 1288 - 1292 FOR HOLD DOWN CLAMPS & C-CLAMPS

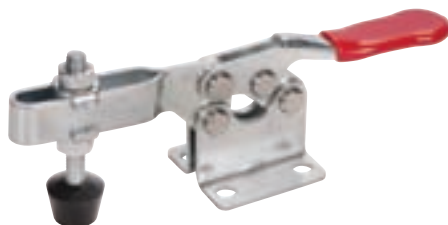

HEAVY-DUTY VARIABLE TEMPERATURE HEAT GUNS

- LCD digital readout display
- Removable air filter
- Ceramic encapsulated heating element
- Thermo protection prevents tool from overheating

Model No. TEA200
Mfg. No. 8988-20
Air volume: Cool air only: 7.06 cu.ft./min.
Low air with heat: 8.83 cu.ft./min.
High air with heat: 15.89 cu.ft./min.
Air temperatures: 90°F-1050°F
Motor: 120 V AC, 12.5 A
Weight: 2.0 lbs.
Price/Each \$283.00



HEAVY-DUTY DUAL TEMPERATURE HEAT GUNS

- Increases surface temperature to required working temperature faster than conventional hot air heat guns
- 3-position rocker switch: off, high and low
- Impact resistant heating element
- Support stand enables gun to be stationary for workbench or assembly work

Model No. TF714
Mfg. No. 8975-6
Air volume: 14.8 cu.ft./min.
Air temperatures: 570° F/1000°F
Motor: 120 V AC, 11.6 A
Weight: 1.6 lbs.
Price/Each \$106.00



ACCESSORIES

AIR REDUCTION NOZZLE

- Intensified heat in a specific area – soldering

Model No. TF373 Mfg. No. 49-80-0297
Price/Each \$22.90



HOOK NOZZLE

- For surround-bending, soldering pipe or shrinking tubing

Model No. TF370 Mfg. No. 49-80-0292
Price/Each \$22.90



DEFLECTOR

- Deflects air away from glass when stripping paint or softening putty

Model No. TF371 Mfg. No. 49-80-0293
Price/Each \$23.20



AIR SPREADER

- Intensified heat for removing floor coverings, paint burning and vinyl top removal

Model No. TF372 Mfg. No. 49-80-0294
Price/Each \$23.20



ACCESSORY ASSORTMENT

- Includes TF373, TF370, TF371 and TF372

Model No. TF374 Mfg. No. 49-80-0300
Price/Each \$58.30

VARIABLE TEMPERATURE HEAT GUNS

- Electronic control for progressive temperature variation
- 3-speed settings
- 13 A, 1400 W
- Air temperatures: 50/350/550°C
- 3 CFM settings: 8.8, 12.4, 17.7

Model No. TKZ033
Mfg. No. HT16-500
Price/Each \$165.00

metabo



HEAT GUNS

- Length: 10 1/2"
- Ergonomic style and powerful heating elements
- The variable temperature adjustment allows you to dial in the proper temperature for your job
- Handle Type: Pistol Grip

Model No. TF715
Mfg. No. 8977-20
Air volume: 20 cu.ft./min.
Air temperatures: 100°F - 1040°F (37°C - 560°C)
Motor: 120 V, 11.6 A
Weight: 1.8 lbs.
Price/Each \$168.00



THERMOCOUPLE HEAT GUNS

- Precise temperature maintained by thermocouple control
- Variable temp. control 250°F - 1100°F
- 2-speed blower setting for 8.8 CFM or 16 CFM
- 12 A
- 10" overall length
- Weight: 1.39 lbs.
- Heating element protected by ceramic core for longer tool life

Model No. TF849
Mfg. No. HG551V
Price/Each \$125.00



ACCESSORIES

| Model No. | Description | Price/Each |
|-----------|--|------------|
| TD196 | Wide-angle slit nozzle | 20.80 |
| TD198 | Reflector nozzle | 22.10 |
| TD199 | PVC plastic welding rods 16/pkg | 23.80 |
| TD200 | ABS plastic welding rods 16/pkg | 22.20 |
| TD201 | Plastic welding nozzle (attaches to D) | 15.00 |
| TD206 | 3/8" reflector nozzle | 24.90 |

SEE PAGES 1469 - 1471 FOR CONTACT & NON-CONTACT THERMOMETERS



1500 W ELECTRONIC HOT AIR GUNS

- Electronically controlled hot air gun with continuously variable temperature
- Ceramic-encapsulated heating element
- Heating element has the Steinel® thermocouple technology

Model No. ZD551
Mfg. No. HG2000E
Price/Each \$315.00

STEINEL
PROFESSIONAL



ACCESSORIES



WJ583



WJ584



WJ585



WJ586



WJ587



WJ588



WJ589



WJ591



WJ592



WJ593

| Model No. | Mfg. No. | Description | Price /Each |
|-----------|----------|----------------------------|-------------|
| WJ583 | 07081-1 | Reduction Nozzle 20 mm | 19.50 |
| WJ584 | 07071-2 | Reduction Nozzle 14 mm | 18.90 |
| WJ585 | 07061-3 | Reduction Nozzle 9 mm | 33.50 |
| WJ586 | 07461-1 | Soldering Reflector Nozzle | 22.50 |
| WJ587 | 07051-4 | Reflector Nozzle | 19.50 |
| WJ588 | 07031-6 | Window Nozzle 50 mm | 18.90 |
| WJ589 | 07011-8 | Surface Nozzle 50 mm | 18.90 |
| WJ591 | 07301-0 | Large Reflector Nozzle | 26.90 |
| WJ592 | 07041-5 | Window Nozzle 75 mm | 18.90 |
| WJ593 | 07021-7 | Surface Nozzle 75 mm | 18.90 |

HB 1750 HEAT BLOWERS

- Powerful turbine blower with air delivery rate up to 23 CFM
- Colour coded keys for the right temperature every time
- Maintenance free factory sealed motor
- Lightweight, well balanced design
- Soft grip handle with convenient slide switch
- Ultra quiet operation
- Plug-in heating element takes only seconds to change
- Quick-lock stand is fully adjustable and stores keys
- Applications: Packaging, paint drying, window tinting, stripping paint, cable assembly
- Includes: Quick lock stand, 5 temperature keys, large reflector, spare element, silver case

Model No TLV254
Mfg. No. 34759
Price/Each \$324.00



ACCESSORIES

| Model No. | Mfg. No. | Description | Price/Each |
|-----------|----------|------------------------------|------------|
| TLV255 | 07695 | 7 mm Reducer Nozzle | 54.50 |
| TLV256 | 07725 | 200 mm Spreader Nozzle | 64.50 |
| TLV257 | 07705 | 50 mm Large Reflector Nozzle | 28.50 |
| TLV258 | 07715 | 20 mm Small Reflector Nozzle | 25.50 |

STEINEL
PROFESSIONAL

HG 2310 LCD PROGRAMMABLE INTELLITEMP™ HOT AIR GUNS

- LCD display enables temperature selection in 10°F increments
- Lockable override control
- Variable temperature and air flow control
- Duratherm™ heating element
- Double insulated
- Net weight: 2.2 lbs.

Model No. THZ793
Mfg. No. 34870
Price/Each \$399.00



ACCESSORIES

| Model No. | Mfg. No. | Description | Price /Each |
|-----------|----------|----------------------------|-------------|
| WJ583 | 07081-1 | Reduction Nozzle 20 mm | 19.50 |
| WJ584 | 07071-2 | Reduction Nozzle 14 mm | 18.90 |
| WJ585 | 07061-3 | Reduction Nozzle 9 mm | 33.50 |
| WJ586 | 07461-1 | Soldering Reflector Nozzle | 22.50 |
| WJ587 | 07051-4 | Reflector Nozzle | 19.50 |
| WJ588 | 07031-6 | Window Nozzle 50 mm | 18.90 |
| WJ589 | 07011-8 | Surface Nozzle 50 mm | 18.90 |
| WJ591 | 07301-0 | Large Reflector Nozzle | 26.90 |
| WJ592 | 07041-5 | Window Nozzle 75 mm | 18.90 |
| WJ593 | 07021-7 | Surface Nozzle 75 mm | 18.90 |

STEINEL
PROFESSIONAL

DREMEL TOOLS, HEAT GUNS & ACCESSORIES

ENGRAVERS

The model **TF191** engraver is the perfect tool for personalizing and protecting your valuables.

- Includes: Engraver Tool, Letter/Number Template & 1 Carbide Point



DREMEL®

| Model No. | Mfg. No. | Description | Price/Each |
|-----------|----------|---------------------------|------------|
| TF191 | 290-01 | Engraver | 37.80 |
| TF794 | 9924 | Carbide replacement point | 8.73 |
| TF796 | 9929 | Diamond engraving point | 27.20 |

DREMEL® TWO-SPEED ROTARY TOOL KITS

- Ideal for multiple applications on a variety of materials
- Two-speed control allows you to set your speed at 15 000 or 35 000 RPM
- **Includes:** 1 attachment and 15 accessories

Model No. WJ132
Mfg. No. 200-1/15
Price/Each \$107.00



DREMEL®

DREMEL® VARIABLE SPEED ROTARY TOOL KITS

- 3000 Series variable speed rotary tool
- The attachments included are: A sanding/grinding guide and a multipurpose cutting guide
- Includes storage case and 28 genuine Dremel® accessories

Model No. TLV170
Mfg. No. 3000-2/28
Price/Each \$169.00



DREMEL® MULTI-MAX OSCILLATING TOOLS

- Multi-tasking tool with fast side-to-side motion
- Optimal control, safe operation, high precision, minimal dust
- For cutting, grinding, sanding, scraping and grout removal

Model No. TLV494
Mfg. No. MM30-04
Price/Each \$221.00



DREMEL®

DREMEL®

DREMEL® MINIMITE CORDLESS ROTARY TOOLS

- Features two speeds and can be used with any Dremel® accessory bit with up to a 1/8" shank
- Ideal performance for small craft projects
- Lightweight and compact for precision and control
- 4.8 V battery and charger

Model No. TLV261
Mfg. No. 7300-N/8
Price/Each \$58.50

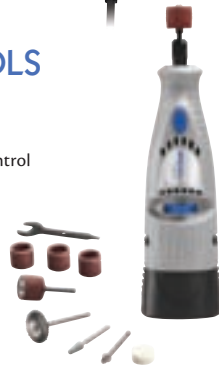

DREMEL® CORDLESS 12 V LITHIUM-ION ROTARY TOOLS

- Fastest, strongest performing cordless rotary tool available
- Can be used with all Dremel® accessories and attachments
- Lithium-ion battery maintains charge up to two years while in storage

Model No. TLY791
Mfg. No. 8220-2/28
Price/Each \$311.00



DREMEL®

DREMEL®

DREMEL® ATTACHMENTS

(ALL ROTARY TOOLS & BITS ARE SOLD SEPARATELY)

FLEX-SHAFT ATTACHMENTS

Flexible 36" shaft allows fingertip control for polishing, carving, sanding, engraving and more.

Model No. TW002
Mfg. No. 225-01
Price/Each \$55.70



WORK STATIONS

Functions as an articulating drill press that rotates 90°, rotary tool holder, and flex-shaft tool stand

- Detents click the tool in place in 15° increments from vertical to horizontal
- "Crow's Nest" provides on-board storage for Dremel® accessories
- Durable, die-cast aluminum base

Model No. TGZ380
Mfg. No. 220-01
Price/Each \$81.90



RIGHT-ANGLE ATTACHMENTS

Allows to get to hard-to-reach areas.

Model No. WJ125
Mfg. No. 575
Price/Each \$44.60



DREMEL® 160 PIECE ACCESSORY SETS

- Comes with re-useable storage case and 160 accessories
- Can stand upright or hang on a wall by hook
- Ideal for cutting, sanding, polishing, grinding, and carving
- A complete start-up kit offering the breadth of accessories helpful for wide assortment of tasks
- Clear lid and eight storage bins make accessories easy to locate

Model No. TYK594
Mfg. No. 710-08
Price/Each \$66.90

DREMEL®



THREAD STEEL HAWG CARBIDE TIPPED CUTTERS

2" CUTTING DEPTH

- Carbide-tipped multiple alternating inside and outside cutting edges
- For steel, cast iron or aluminum
- 3 times faster than twist drills in steel, stainless or non-ferrous metals



VH110

| Dia." | Model No. | Price /Each | Dia." | Model No. | Price /Each | Dia." | Model No. | Price /Each |
|---------|-----------|-------------|---------|-----------|-------------|-------|-----------|-------------|
| 3/4 | VH101 | 155.00 | 1 3/16 | VH180 | 492.00 | 3 3/8 | VH241 | 1156.00 |
| 13/16 | VH106 | 168.00 | 1 7/8 | VH185 | 520.00 | 3 1/2 | VH242 | 1227.00 |
| 7/8 | VH110 | 176.00 | 1 15/16 | VH190 | 555.00 | 3 5/8 | VH244 | 1296.00 |
| 15/16 | VH115 | 190.00 | 2 | VH194 | 577.00 | 3 3/4 | VH245 | 1365.00 |
| 1 | VH119 | 207.00 | 2 1/16 | VH198 | 601.00 | 3 7/8 | VH247 | 1429.00 |
| 1 1/16 | VH124 | 209.00 | 2 1/8 | VH201 | 625.00 | 4 | VH249 | 1498.00 |
| 1 1/8 | VH129 | 247.00 | 2 1/4 | VH205 | 653.00 | 4 1/8 | VH250 | 1510.00 |
| 1 3/16 | VH133 | 258.00 | 2 5/16 | VH208 | 677.00 | 4 1/4 | VH251 | 1579.00 |
| 1 1/4 | VH139 | 264.00 | 2 3/8 | VH210 | 705.00 | 4 3/8 | VH252 | 1662.00 |
| 1 5/16 | VH143 | 282.00 | 2 1/2 | VH215 | 734.00 | 4 1/2 | VH253 | 1749.00 |
| 1 3/8 | VH148 | 295.00 | 2 9/16 | VH217 | 762.00 | 4 5/8 | VH254 | 1858.00 |
| 1 7/16 | VH153 | 339.00 | 2 5/8 | VH220 | 795.00 | 4 3/4 | VH255 | 2079.00 |
| 1 1/2 | VH157 | 354.00 | 2 3/4 | VH224 | 826.00 | 5 | VH256 | 2345.00 |
| 1 9/16 | VH162 | 397.00 | 2 7/8 | VH228 | 911.00 | 5 1/2 | VH257 | 2993.00 |
| 1 5/8 | VH166 | 427.00 | 3 | VH232 | 956.00 | 6 | VH258 | 3654.00 |
| 1 11/16 | VH171 | 442.00 | 3 1/8 | VH236 | 1018.00 | | | |
| 1 3/4 | VH175 | 470.00 | 3 1/4 | VH239 | 1090.00 | | | |

ARBOR ASSEMBLIES FOR THREADED SHANK STEEL HAWG CUTTERS

3/4" SHANK ARBOR ASSEMBLY

For use on motors TF328. Oil hose and hand pump not included.

Model No. VH080 Price/Each \$211.00



VH080

NO. 3 MORSE TAPER QUICK ARBOR ASSEMBLY

For use on motors TF334 and TF335. Oil hose and hand pump not included.

Model No. TEA295 Price/Each \$259.00



TEA295

NO. 3 MORSE TAPER ASSEMBLY

For use on motors TF328. No. 3 Morse taper assembly will allow 3/4" Weldon style shank cutters to be used with Milwaukee's large magnetic drill stands.

Model No. VH074 Price/Each \$211.00

ANNULAR CUTTERS

- M2 quality high speed steel
- Right-hand cutting direction
- 3/4" Weldon shank

Applications:

- For general purpose cutting of steel plate, structural steel, steel pipe, etc
- 3 to 5 X faster cutting than conventional drills
- Produces quality burr-free hole in a single pass
- Ideal for magnetic base drill, drill presses and milling machines



CLARKSON OSBORN

1" DEPTH OF CUT

2" DEPTH OF CUT

3" DEPTH OF CUT

| Fractional Size" | Model No. | Price /Each | Fractional Size" | Model No. | Price /Each | Fractional Size" | Model No. | Price /Each |
|------------------|-----------|-------------|------------------|-----------|-------------|------------------|-----------|-------------|
| 1/2 | TFX101 | 42.40 | 1/2 | TFX129 | 68.90 | 3/4 | TFX156 | 185.00 |
| 9/16 | TFX102 | 47.30 | 9/16 | TFX130 | 75.00 | 13/16 | TFX157 | 195.00 |
| 5/8 | TFX103 | 49.20 | 5/8 | TFX131 | 81.10 | 7/8 | TFX158 | 204.00 |
| 11/16 | TFX104 | 52.90 | 11/16 | TFX132 | 89.80 | 15/16 | TFX159 | 211.00 |
| 3/4 | TFX105 | 54.00 | 3/4 | TFX133 | 93.50 | 1 | TFX160 | 223.00 |
| 13/16 | TFX106 | 60.20 | 13/16 | TFX134 | 103.00 | 1 1/16 | TFX161 | 241.00 |
| 7/8 | TFX107 | 62.70 | 7/8 | TFX135 | 106.00 | 1 1/8 | TFX162 | 255.00 |
| 15/16 | TFX108 | 67.60 | 15/16 | TFX136 | 112.00 | 1 3/16 | TFX163 | 274.00 |
| 1 | TFX109 | 70.10 | 1 | TFX137 | 114.00 | 1 1/4 | TFX164 | 301.00 |
| 1 1/16 | TFX110 | 73.20 | 1 1/16 | TFX138 | 123.00 | 1 5/16 | TFX165 | 332.00 |
| 1 1/8 | TFX111 | 80.00 | 1 1/8 | TFX139 | 135.00 | 1 3/8 | TFX166 | 362.00 |
| 1 3/16 | TFX112 | 82.30 | 1 3/16 | TFX140 | 140.00 | 1 7/16 | TFX167 | 369.00 |
| 1 1/4 | TFX113 | 111.00 | 1 1/4 | TFX141 | 160.00 | 1 1/2 | TFX168 | 383.00 |
| 1 5/16 | TFX114 | 116.00 | 1 5/16 | TFX142 | 165.00 | 1 9/16 | TFX169 | 403.00 |
| 1 3/8 | TFX115 | 150.00 | 1 3/8 | TFX143 | 186.00 | 1 5/8 | TFX170 | 436.00 |
| 1 7/16 | TFX116 | 165.00 | 1 7/16 | TFX144 | 196.00 | 1 11/16 | TFX171 | 445.00 |
| 1 1/2 | TFX117 | 167.00 | 1 1/2 | TFX145 | 199.00 | 1 3/4 | TFX172 | 464.00 |
| 1 9/16 | TFX118 | 180.00 | 1 9/16 | TFX146 | 214.00 | 1 13/16 | TFX173 | 501.00 |
| 1 5/8 | TFX119 | 184.00 | 1 5/8 | TFX147 | 224.00 | 1 7/8 | TFX174 | 538.00 |
| 1 11/16 | TFX120 | 199.00 | 1 11/16 | TFX148 | 236.00 | 1 15/16 | TFX175 | 547.00 |
| 1 3/4 | TFX121 | 211.00 | 1 3/4 | TFX149 | 246.00 | 2 | TFX176 | 566.00 |
| 1 13/16 | TFX122 | 234.00 | 1 13/16 | TFX150 | 266.00 | 2 1/16 | TFX177 | 640.00 |
| 1 7/8 | TFX123 | 246.00 | 1 7/8 | TFX151 | 285.00 | - | - | - |
| 1 15/16 | TFX124 | 256.00 | 1 15/16 | TFX152 | 290.00 | - | - | - |
| 2 | TFX125 | 271.00 | 2 | TFX153 | 300.00 | - | - | - |
| 2 1/16 | TFX126 | 290.00 | 2 1/16 | TFX154 | 330.00 | - | - | - |
| 2 1/4 | TFX127 | 374.00 | 2 1/4 | TFX155 | 389.00 | - | - | - |

Cut pin required TFX178
Price/Each \$8.34

Cut pin required TFX179
Price/Each \$9.72

Cut pin required TFX180
Price/Each \$17.40

CUTTER, CORE & DRILL BITS



THIN WALL CORE BITS

CUP, CENTRE PIN & GUIDE PLATE ONLY

| Bit Size" | Model No. | Price /Each |
|-----------|-----------|-------------|
| 1 1/2 | TE977 | 106.00 |
| 1 3/4 | TE978 | 119.00 |
| 2 | TE979 | 182.00 |
| 2 1/2 | TE980 | 127.00 |
| 3 | TE981 | 174.00 |
| 3 1/2 | TE982 | 209.00 |
| 4 | TE983 | 313.00 |
| 5 | TE984 | 383.00 |
| 6 | TE985 | 521.00 |



Usable cut depth of 3".



REPLACEMENT GUIDE PLATES

| Bit Size" | Model No. | Price /Each |
|-----------|-----------|-------------|
| 1 1/2 | TE988 | 6.16 |
| 1 3/4 | TE989 | 6.54 |
| 2 | TE990 | 7.09 |
| 2 1/2 | TE991 | 7.81 |
| 3 | TE992 | 9.00 |
| 3 1/2 | TE993 | 10.40 |
| 4 | TE994 | 11.60 |
| 5 | TE995 | 19.40 |
| 6 | TE996 | 21.70 |



THICK WALL CORE BITS

CUP, CENTRE PIN & GUIDE PLATE ONLY

| Bit Size" | Model No. | Price /Each |
|-----------|-----------|-------------|
| 1 1/2 | TJ012 | 195.00 |
| 1 3/4 | TJ013 | 183.00 |
| 2 | TJ014 | 217.00 |
| 2 1/2 | TJ015 | 260.00 |
| 3 | TJ016 | 323.00 |
| 3 1/2 | TJ017 | 372.00 |
| 4 | TJ018 | 392.00 |
| 5 | TJ019 | 441.00 |
| 6 | TJ020 | 547.00 |



Usable cut depth of 4 3/8"



REPLACEMENT GUIDE PLATES

| Bit Size" | Model No. | Price /Each |
|-----------|-----------|-------------|
| 1 1/2 | TJ023 | 11.50 |
| 1 3/4 | TJ024 | 12.90 |
| 2 | TJ025 | 14.20 |
| 2 1/2 | TJ026 | 16.70 |
| 3 | TJ027 | 17.90 |
| 3 1/2 | TJ028 | 21.70 |
| 4 | TJ029 | 24.50 |
| 5 | TJ030 | 30.30 |
| 6 | TJ031 | 35.50 |



SDS+ THIN WALL CORE BIT ADAPTERS

(Not included with core bit)

| Model No. | Mfg. No. | Length" | Price /Each |
|---|------------|---------|-------------|
| FOR USE WITH 1" TO 1 1/2" CORE BITS | | | |
| TE997 | 48-03-3545 | 8 | 61.10 |
| TE998 | 48-03-3551 | 12 | 69.70 |
| FOR USE WITH 1 3/4" TO 3 1/2" CORE BITS | | | |
| TE999 | 48-03-3555 | 8 | 61.10 |
| TJ001 | 48-03-3561 | 12 | 69.70 |



SPLINE THICK WALL CORE BIT ADAPTERS

(Not included with core bit)

| Model No. | Mfg. No. | Length" | Price /Each |
|------------------------------------|------------|---------|-------------|
| FOR USE WITH 1 1/2" TO 6" CORE BIT | | | |
| TJ034 | 48-03-3564 | 12 | 119.00 |
| TJ035 | 48-03-3565 | 18 | 146.00 |



SPLINE THIN WALL CORE BIT ADAPTERS

(Not included with core bit)

| Model No. | Mfg. No. | Length" | Price /Each |
|-------------------------------------|------------|---------|-------------|
| FOR USE WITH 1 3/4" TO 6" CORE BITS | | | |
| TJ004 | 48-03-3540 | 12 | 65.80 |



REPLACEMENT CENTRE PINS

For 1 1/4" to 1 1/2" core bit

Model No. TJ006 Mfg. No. 48-20-6150
Price/Each \$25.50

For 1 3/4" to 6" core bit

Model No. TJ007 Mfg. No. 48-20-6155
Price/Each \$25.50



1" and 1/8" core bits do not require centre pins

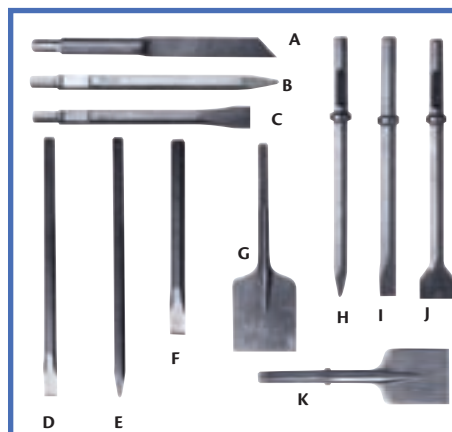

POINTS & CHISELS

| Model No. | Mfg. No. | Description | Code | Shank Type | Price /Each |
|-----------|------------|---------------------------------|------|--------------------------|-------------|
| TJ154 | 48-62-2080 | Mortar cutting chisel 12" | A | For spline drive hammers | 48.20 |
| TJ156 | 48-62-2000 | Bull point 12" | B | For spline drive hammers | 22.10 |
| TJ157 | 48-62-2010 | Bull point 18" | B | For spline drive hammers | 28.90 |
| TJ158 | 48-62-2040 | Scaling chisel 1 1/4" W x 12" L | C | For spline drive hammers | 34.80 |
| TJ159 | 48-62-2050 | Scaling chisel 2" W x 12" L | C | For spline drive hammers | 38.30 |
| TJ160 | 48-62-3000 | Bull point 12" | D | 3/4" hex | 16.40 |
| TJ161 | 48-62-3005 | Bull point 18" | E | 3/4" hex | 22.20 |
| TJ162 | 48-62-3010 | Flat chisel 12" | F | 3/4" hex | 16.40 |
| TJ164 | 48-62-3090 | Asphalt cutter 16 1/2" | G | 3/4" hex | 126.00 |
| TJ165 | 48-62-4000 | Moil point 20" | H | Ringed 1 1/8" hex | 41.20 |
| TJ166 | 48-62-4005 | Narrow chisel 20 1/2" | I | Ringed 1 1/8" hex | 42.90 |
| TJ167 | 48-62-4010 | Chisel 3" - 20 1/2" | J | Ringed 1 1/8" hex | 53.80 |
| TJ168 | 48-62-4020 | Asphalt cutter 5" W x 17 1/2" L | K | Ringed 1 1/8" hex | 120.00 |



GROO-V TIP MULTI-PURPOSE SPECIALTY CARBIDE TIPPED DRILL BITS

- Specialized Ram Tip® bits w/serrated carbide tip, allows drilling up to 50% faster than standard masonry bits

Application: Percussion or rotary, hard metals, plastic, masonry, tile, wood, marble, granite

RELTON



| Size" | Shank" | Overall Length" | Drill Depth" | Model No. | Price /Each |
|-------|--------|-----------------|--------------|-----------|-------------|
| 3/16 | 3/16 | 3 | 1 7/8 | TGX973 | 9.18 |
| 3/16 | 3/16 | 4 | 2 3/8 | TGX974 | 10.00 |
| 1/4 | 1/4 | 4 | 2 1/4 | TGX976 | 10.00 |
| 1/4 | 1/4 | 6 | 3 3/4 | TGX977 | 10.80 |
| 5/16 | 1/4 | 6 | 4 | TGX980 | 13.40 |
| 3/8 | 3/8 | 6 | 4 | TGX982 | 14.20 |
| 1/2 | 3/8 | 6 | 4 | TGX984 | 17.50 |
| 5/8 | 1/2 | 6 | 4 | TGX968 | 25.00 |
| 3/4 | 1/2 | 6 | 4 | TGX970 | 30.90 |
| 1 | 1/2 | 6 | 4 | TGX972 | 52.60 |

5-PC. GROO-V TIP SETS

- Includes: 3/16", 1/4", 5/16", 3/8", 1/2"
- Model No. TGX986
Price/Each \$62.60



SDS+ SHANKS

RELTON



| Size" | Overall Length" | Drill Depth" | Model No. | Price /Each |
|-------|-----------------|--------------|-----------|-------------|
| 5/32 | 6 | 4 | TGX766 | 12.50 |
| 5/32 | 8 | 6 | TGX770 | 13.40 |
| 3/16 | 4 | 2 | TGX778 | 6.68 |
| 3/16 | 6 | 4 | TGX779 | 7.51 |
| 3/16 | 8 | 6 | TGX780 | 9.18 |
| 3/16 | 10 | 8 | TGX776 | 18.40 |
| 3/16 | 14 | 12 | TGX777 | 26.70 |
| 7/32 | 6 | 4 | TGX775 | 10.00 |
| 7/32 | 10 | 8 | TGX773 | 20.90 |
| 7/32 | 16 | 14 | TGX774 | 28.40 |
| 1/4 | 4 | 2 | TGX785 | 6.68 |
| 1/4 | 6 | 4 | TGX786 | 7.51 |
| 1/4 | 8 | 6 | TGX787 | 9.18 |
| 1/4 | 10 | 8 | TGX782 | 15.90 |
| 1/4 | 14 | 12 | TGX783 | 20.90 |
| 1/4 | 20 | 18 | TGX784 | 24.20 |
| 9/32 | 8 | 6 | TGX781 | 16.70 |
| 5/16 | 6 | 4 | TGX790 | 10.80 |
| 5/16 | 10 | 8 | TGX788 | 17.50 |
| 5/16 | 14 | 12 | TGX789 | 20.90 |
| 3/8 | 6 | 4 | TGX795 | 9.18 |
| 3/8 | 10 | 8 | TGX791 | 17.50 |
| 3/8 | 14 | 12 | TGX792 | 21.70 |
| 3/8 | 18 | 16 | TGX793 | 31.70 |
| 3/8 | 25 | 22 | TGX794 | 47.60 |
| 7/16 | 6 | 4 | TGX797 | 17.50 |
| 7/16 | 12 | 10 | TGX796 | 21.70 |
| 1/2 | 6 | 4 | TGX802 | 11.70 |
| 1/2 | 10 | 8 | TGX798 | 24.20 |
| 1/2 | 14 | 12 | TGX799 | 29.20 |
| 1/2 | 18 | 16 | TGX800 | 37.60 |
| 1/2 | 25 | 22 | TGX801 | 49.20 |
| 9/16 | 6 | 4 | TGX806 | 20.90 |
| 9/16 | 12 | 10 | TGX803 | 30.00 |
| 9/16 | 18 | 16 | TGX804 | 42.60 |

5-PC. SDS+ DRILL SETS

- Includes: 3/16" x 6", 1/4" x 6", 5/16" x 6", 3/8" x 6", 1/2" x 6"

Model No. THZ772
Price/Each \$48.40



CARBIDE TIPPED ROTARY REBAR CUTTERS

- No need to relocate the hole to avoid the rebar
- Teeth can be sharpened or replaced as necessary
- Shank has three flats to eliminate slippage in 3-jaw chuck
- Design to drill dry, no water or coolant required
- Carbide teeth design for rotary use only
- To be used with rotary function only, percussion will break the carbide teeth
- Available in 1/2" straight shank or SDS shank

RELTON



1. Stop hammer bit when rebar is encountered



2. Using same size rebar cutter as masonry bit, rotary only through rebar



3. Return to hammer drilling to desired depth



Removable

Non-removable

| Size" | Style | Overall Length" | Model No. | Price /Each |
|-----------------------|---------------|-----------------|-----------|-------------|
| STRAIGHT SHANK | | | | |
| 3/8 | Non-Removable | 8 | TGY282 | 49.20 |
| 1/2 | Non-Removable | 12 | TGY283 | 50.90 |
| 1/2 | Non-Removable | 18 | TGY284 | 76.80 |
| 9/16 | Non-Removable | 12 | TGY285 | 59.30 |
| 5/8 | Non-Removable | 12 | TGY257 | 61.80 |
| 5/8 | Non-Removable | 18 | TGY258 | 82.60 |
| 11/16 | Non-Removable | 12 | TGY259 | 70.10 |
| 3/4 | Non-Removable | 12 | TGY260 | 70.90 |
| 3/4 | Non-Removable | 18 | TGY262 | 91.00 |
| 3/4 | Non-Removable | 24 | TGY261 | 104.00 |
| 13/16 | Non-Removable | 12 | TGY263 | 76.80 |
| 7/8 | Removable | 12 | TGY264 | 98.50 |
| 1 | Removable | 12 | TGY266 | 103.00 |
| 1 1/8 | Removable | 12 | TGY268 | 121.00 |
| 1 1/4 | Removable | 12 | TGY270 | 127.00 |
| 1 3/8 | Removable | 12 | TGY272 | 129.00 |
| 1 1/2 | Removable | 12 | TGY274 | 141.00 |
| 1 3/4 | Removable | 12 | TGY276 | 178.00 |
| 2 | Removable | 12 | TGY278 | 200.00 |
| 2 1/2 | Removable | 12 | TGY280 | 217.00 |
| SDS+ SHANK | | | | |
| 3/8 | Non-Removable | 8 | TB0279 | 50.90 |
| 1/2 | Non-Removable | 12 | TB0280 | 53.40 |
| 1/2 | Non-Removable | 18 | TB0281 | 79.30 |
| 9/16 | Non-Removable | 12 | TB0282 | 60.90 |
| 5/8 | Non-Removable | 12 | TB0283 | 63.40 |
| 5/8 | Non-Removable | 18 | TB0284 | 84.30 |
| 11/16 | Non-Removable | 12 | TB0285 | 71.80 |
| 3/4 | Non-Removable | 12 | TB0286 | 72.60 |
| 3/4 | Non-Removable | 18 | TB0287 | 92.60 |
| 3/4 | Non-Removable | 24 | TB0288 | 106.00 |
| 13/16 | Non-Removable | 12 | TB0289 | 79.30 |
| 7/8 | Removable | 12 | TB0290 | 101.00 |
| 1 | Removable | 12 | TB0291 | 105.00 |
| 1 1/8 | Removable | 12 | TB0292 | 124.00 |
| 1 1/4 | Removable | 12 | TB0293 | 129.00 |
| 1 3/8 | Removable | 12 | TB0294 | 131.00 |
| 1 1/2 | Removable | 12 | TB0295 | 144.00 |
| 2 | Removable | 12 | TB0297 | 204.00 |
| 2 1/2 | Removable | 12 | TB0298 | 220.00 |

CUTTER, CORE & DRILL BITS

SPLINE SHANKS



SDS-MAX



| Size" | Overall Length" | Drill Depth" | Model No. | Price /Each |
|-------|-----------------|--------------|-----------|-------------|
| 3/8 | 10 | 4 | TGX736 | 45.10 |
| 3/8 | 14 | 8 | TGX737 | 46.70 |
| 3/8 | 18 | 12 | TGX738 | 51.70 |
| 7/16 | 14 | 8 | TGX739 | 46.70 |
| 1/2 | 14 | 8 | TGX740 | 46.70 |
| 1/2 | 18 | 12 | TGX741 | 51.70 |
| 1/2 | 22 | 16 | TGX742 | 65.90 |
| 1/2 | 28 | 22 | TGX743 | 79.30 |
| 9/16 | 14 | 8 | TGX745 | 50.90 |
| 9/16 | 18 | 12 | TGX746 | 58.40 |
| 9/16 | 22 | 16 | TGX747 | 70.10 |
| 9/16 | 28 | 22 | TGX748 | 85.10 |
| 5/8 | 14 | 8 | TGX696 | 50.90 |
| 5/8 | 18 | 12 | TGX697 | 59.30 |
| 5/8 | 22 | 16 | TGX698 | 75.10 |
| 3/4 | 14 | 8 | TGX703 | 56.80 |
| 3/4 | 18 | 12 | TGX704 | 66.80 |
| 3/4 | 22 | 16 | TGX705 | 77.60 |
| 7/8 | 14 | 8 | TGX712 | 59.30 |
| 7/8 | 18 | 12 | TGX713 | 70.90 |
| 7/8 | 22 | 16 | TGX714 | 82.60 |
| 1 | 14 | 8 | TGX717 | 64.30 |
| 1 | 18 | 12 | TGX718 | 77.60 |
| 1 | 22 | 16 | TGX719 | 96.00 |
| 1 1/8 | 14 | 8 | TGX722 | 81.00 |
| 1 1/8 | 22 | 16 | TGX723 | 99.30 |
| 1 1/4 | 14 | 8 | TGX726 | 94.30 |
| 1 1/4 | 22 | 16 | TGX727 | 115.00 |
| 1 3/8 | 22 | 16 | TGX730 | 134.00 |
| 1 1/2 | 14 | 8 | TGX732 | 111.00 |
| 1 1/2 | 22 | 16 | TGX733 | 156.00 |

Additional sizes available

| Size" | Overall Length" | Drill Depth" | Model No. | Price /Each |
|-------|-----------------|--------------|-----------|-------------|
| 3/8 | 10 | 4 | TGY166 | 51.70 |
| 3/8 | 14 | 8 | TGY167 | 52.60 |
| 3/8 | 18 | 12 | TGY168 | 59.30 |
| 7/16 | 14 | 8 | TGY169 | 52.60 |
| 1/2 | 14 | 8 | TGY170 | 53.40 |
| 1/2 | 18 | 12 | TGY171 | 59.70 |
| 1/2 | 22 | 16 | TGY172 | 73.40 |
| 1/2 | 28 | 22 | TGY173 | 81.00 |
| 9/16 | 14 | 8 | TGY175 | 59.30 |
| 9/16 | 18 | 12 | TGY176 | 66.80 |
| 9/16 | 22 | 16 | TGY177 | 79.30 |
| 9/16 | 28 | 22 | TGY178 | 97.60 |
| 5/8 | 14 | 8 | TGY126 | 59.30 |
| 5/8 | 18 | 12 | TGY127 | 67.60 |
| 5/8 | 22 | 16 | TGY128 | 84.30 |
| 3/4 | 14 | 8 | TGY133 | 63.40 |
| 3/4 | 18 | 12 | TGY134 | 75.90 |
| 3/4 | 22 | 16 | TGY135 | 87.60 |
| 7/8 | 14 | 8 | TGY142 | 66.80 |
| 7/8 | 18 | 12 | TGY143 | 81.00 |
| 7/8 | 22 | 16 | TGY144 | 95.10 |
| 1 | 14 | 8 | TGY147 | 72.60 |
| 1 | 18 | 12 | TGY148 | 88.50 |
| 1 | 22 | 16 | TGY149 | 107.00 |
| 1 1/8 | 14 | 8 | TGY152 | 90.10 |
| 1 1/8 | 22 | 16 | TGY153 | 113.00 |
| 1 1/4 | 14 | 8 | TGY156 | 104.00 |
| 1 1/4 | 22 | 16 | TGY157 | 129.00 |
| 1 3/8 | 22 | 16 | TGY160 | 150.00 |
| 1 1/2 | 14 | 8 | TGY162 | 124.00 |
| 1 1/2 | 22 | 16 | TGY163 | 175.00 |

Additional sizes available

SPLINE SHANKS PYRAMID POINT



| Model No. | Size" | OAL" | Drill Depth" | Price /Each |
|-----------|-------|------|--------------|-------------|
| TGY184 | 5/8 | 14 | 8 | 59.30 |
| TGY185 | 5/8 | 18 | 12 | 68.40 |
| TGY186 | 5/8 | 22 | 16 | 85.10 |
| TGY187 | 5/8 | 42 | 36 | 165.00 |
| TGY188 | 3/4 | 14 | 8 | 64.30 |
| TGY189 | 3/4 | 18 | 12 | 77.60 |
| TGY190 | 3/4 | 22 | 16 | 89.30 |
| TGY191 | 3/4 | 42 | 36 | 175.00 |
| TGY192 | 7/8 | 14 | 8 | 67.60 |

| Model No. | Size" | OAL" | Drill Depth" | Price /Each |
|-----------|-------|------|--------------|-------------|
| TGY193 | 7/8 | 18 | 12 | 82.60 |
| TGY194 | 7/8 | 22 | 16 | 97.60 |
| TGY195 | 7/8 | 42 | 36 | 199.00 |
| TGY196 | 1 | 14 | 8 | 73.40 |
| TGY197 | 1 | 18 | 12 | 89.30 |
| TGY198 | 1 | 22 | 16 | 110.00 |
| TGY199 | 1 | 42 | 36 | 235.00 |
| TGY200 | 1 1/8 | 14 | 8 | 92.60 |
| TGY201 | 1 1/8 | 22 | 16 | 114.00 |

| Model No. | Size" | OAL" | Drill Depth" | Price /Each |
|-----------|-------|------|--------------|-------------|
| TGY202 | 1 1/8 | 42 | 36 | 291.00 |
| TGY203 | 1 1/4 | 14 | 8 | 108.00 |
| TGY204 | 1 1/4 | 22 | 16 | 133.00 |
| TGY205 | 1 1/4 | 42 | 36 | 300.00 |
| TGY206 | 1 3/8 | 22 | 16 | 155.00 |
| TGY207 | 1 3/8 | 42 | 36 | 366.00 |
| TGY208 | 1 1/2 | 14 | 8 | 126.00 |
| TGY209 | 1 1/2 | 22 | 16 | 180.00 |
| TGY210 | 1 1/2 | 42 | 36 | 396.00 |

SDS-MAX PYRAMID POINT



| Model No. | Size" | OAL" | Drill Depth" | Price /Each |
|-----------|-------|------|--------------|-------------|
| TGY220 | 5/8 | 14 | 8 | 61.80 |
| TGY221 | 5/8 | 18 | 12 | 70.10 |
| TGY222 | 5/8 | 22 | 16 | 88.50 |
| TGY223 | 5/8 | 42 | 36 | 170.00 |
| TGY224 | 3/4 | 14 | 8 | 67.60 |
| TGY225 | 3/4 | 18 | 12 | 79.30 |
| TGY226 | 3/4 | 22 | 16 | 91.00 |
| TGY227 | 3/4 | 42 | 36 | 180.00 |
| TGY228 | 7/8 | 14 | 8 | 70.10 |

| Model No. | Size" | OAL" | Drill Depth" | Price /Each |
|-----------|-------|------|--------------|-------------|
| TGY229 | 7/8 | 18 | 12 | 84.30 |
| TGY230 | 7/8 | 22 | 16 | 100.00 |
| TGY231 | 7/8 | 42 | 36 | 205.00 |
| TGY232 | 1 | 14 | 8 | 78.50 |
| TGY233 | 1 | 18 | 12 | 91.80 |
| TGY234 | 1 | 22 | 16 | 113.00 |
| TGY235 | 1 | 42 | 36 | 240.00 |
| TGY236 | 1 1/8 | 14 | 8 | 96.00 |
| TGY237 | 1 1/8 | 22 | 16 | 119.00 |

| Model No. | Size" | OAL" | Drill Depth" | Price /Each |
|-----------|-------|------|--------------|-------------|
| TGY238 | 1 1/8 | 42 | 36 | 299.00 |
| TGY239 | 1 1/4 | 14 | 8 | 111.00 |
| TGY240 | 1 1/4 | 22 | 16 | 135.00 |
| TGY241 | 1 1/4 | 42 | 36 | 305.00 |
| TGY242 | 1 3/8 | 22 | 16 | 158.00 |
| TGY243 | 1 3/8 | 42 | 36 | 371.00 |
| TGY244 | 1 1/2 | 14 | 8 | 132.00 |
| TGY245 | 1 1/2 | 22 | 16 | 184.00 |
| TGY246 | 1 1/2 | 42 | 36 | 398.00 |

STRAIGHT SHANKS



| Size" | Shank" | Overall Length" | Drill Depth" | Model No. | Price /Each |
|-------|--------|-----------------|--------------|-----------|-------------|
| 1/8 | 1/8 | 3 | 1 3/4 | TGY342 | 3.34 |
| 3/16 | 3/16 | 4 | 2 1/2 | TGY343 | 2.84 |
| 1/4 | 1/4 | 4 | 2 1/2 | TGY345 | 3.25 |
| 1/4 | 1/4 | 6 | 4 | TGY346 | 4.17 |
| 1/4 | 1/4 | 12 | 10 | TGY344 | 10.50 |
| 5/16 | 1/4 | 4 | 2 1/2 | TGY348 | 4.17 |
| 5/16 | 1/4 | 6 | 4 | TGY349 | 4.67 |
| 5/16 | 1/4 | 12 | 10 | TGY347 | 10.50 |
| 3/8* | 1/4 | 4 | 2 1/2 | TGY351 | 4.26 |
| 3/8* | 1/4 | 6 | 4 | TGY352 | 5.76 |
| 3/8* | 3/8 | 12 | 10 | TGY350 | 13.20 |
| 7/16* | 1/4 | 6 | 2 1/2 | TGY353 | 6.59 |
| 7/16* | 1/4 | 6 | 4 | TGY354 | 7.43 |
| 1/2* | 1/4 | 4 | 2 1/2 | TGY356 | 6.26 |

| Size" | Shank" | Overall Length" | Drill Depth" | Model No. | Price /Each |
|--------|--------|-----------------|--------------|-----------|-------------|
| 1/2* | 1/4 | 6 | 4 | TGY358 | 7.51 |
| 1/2* | 3/8 | 6 | 4 | TGY357 | 7.51 |
| 1/2* | 3/8 | 12 | 10 | TGY355 | 14.00 |
| 9/16* | 3/8 | 6 | 4 | TGY359 | 9.68 |
| 5/8* | 1/2 | 6 | 4 | TGY334 | 10.20 |
| 5/8* | 1/2 | 12 | 10 | TGY333 | 17.50 |
| 11/16* | 1/2 | 6 | 4 | TGY335 | 14.00 |
| 3/4* | 1/2 | 6 | 4 | TGY337 | 14.20 |
| 3/4* | 1/2 | 12 | 10 | TGY336 | 23.80 |
| 7/8* | 1/2 | 6 | 4 | TGY339 | 15.90 |
| 7/8* | 1/2 | 12 | 10 | TGY338 | 26.30 |
| 1* | 1/2 | 6 | 4 | TGY341 | 23.00 |
| 1* | 1/2 | 12 | 10 | TGY340 | 36.30 |

*Three flats on shank to eliminate slippage

ICE HARDENED™ HOLE SAW KITS

Ice Hardened™ products utilize a proprietary cryogenic hardening process (harden to the core by minimizing soft metal and creating more hard metal) that improves upon traditional heat treat processes.

Features and benefits:

- Ice Hardened™ for up to 50% longer life
- Optimized tooth form for up to 2x faster cutting
- Functional slots for faster plug removal



15-PC GENERAL PURPOSE ICE HARDENED™ HOLE SAW KIT

Comes with:

- Eleven (11) hole saws: 3/4", 7/8", 1", 1 1/8", 1 3/8", 1 1/2", 1 3/4", 2", 2 1/8", 2 1/4", 2 1/2"
- Two (2) arbors: **VH701, TBO276**
- Two (2) drill bits: **TW232**
- One (1) adapter: **VH066**
- One (1) spacer: **VH435**
- Space for additional hole saws

Model No. TBO157
Price/Each \$212.00



19-PC MASTER ELECTRICIANS ICE HARDENED™ HOLE SAW KIT

Comes with:

- Fourteen (14) hole saws: 3/4", 7/8", 1 1/8", 1 3/8", 1 1/2", 1 3/4", 2", 2 1/4", 2 1/2", 2 5/8", 3", 3 5/8", 4 1/8", 4 3/4"
- Two (2) arbors: **VH701, TBO276**
- Three (3) drill bits: **TW232**
- One (1) adapter: **VH066**
- One (1) spacer: **VH435**
- Space for additional hole saws

Model No. TBO159
Price/Each \$317.00



28-PC ALL PURPOSE PROFESSIONAL ICE HARDENED™ HOLE SAW KIT

Comes with:

- Twenty-two (22) hole saws: 3/4", 7/8", 1", 1 1/8", 1 1/4", 1 3/8", 1 1/2", 1 3/4", 2", 2 1/8", 2 1/4", 2 1/2", 2 5/8", 3", 3 1/4", 3 3/8", 3 5/8", 3 3/4", 4 1/8", 4 1/4", 4 1/2", 4 3/4"
- Three (3) arbors: **VH070, VH701, TBO276**
- Three (3) drill bits: **TW232**
- Space for additional hole saws

Model No. TBO165
Price/Each \$512.00



10-PC PLUMBERS ICE HARDENED™ HOLE SAW KIT

Comes with:

- Six (6) hole saws: 3/4", 7/8", 1 1/8", 1 1/2", 1 3/4", 2 1/4"
- Two (2) arbors: **VH701, TBO276**
- Two (2) drill bits: **TW232**
- One (1) adapter: **VH066**
- One (1) spacer: **VH435**
- Space for additional hole saws

Model No. TBO163
Price/Each \$137.00



10-PC ELECTRICIANS ICE HARDENED™ HOLE SAW KIT

Comes with:

- Six (6) hole saws: 7/8", 1 1/8", 1 1/8", 1 1/4", 2", 2 1/2"
- Two (2) arbors: **VH701, TBO276**
- Two (2) drill bits: **TW232**
- One (1) adapter: **VH066**
- One (1) spacer: **VH435**
- Space for additional hole saws

Model No. TBO160
Price/Each \$143.00



18-PC MASTER PLUMBERS ICE HARDENED™ HOLE SAW KIT

Comes with:

- Thirteen (13) hole saws: 3/4", 7/8", 1 1/8", 1 3/8", 1 1/2", 1 3/4", 2 1/4", 2 5/8", 3", 3 1/2", 4", 4 1/4", 4 1/2"
- Two (2) arbors: **VH701, TBO276**
- Three (3) drill bits: **TW232**
- One (1) adapter: **VH066**
- One (1) spacer: **VH435**
- Space for additional hole saws

Model No. TBO164
Price/Each \$315.00



BIG HAWG® KITS

Big Hawk® hole cutters are specifically designed for drilling large holes in rough wood applications.

Features and benefits:

- Aggressive tooth geometry for up to ten times faster cutting than hole saws
- Deep gullets for easy plug removal
- Three hardened steel teeth provide maximum durability against unintended nail impacts.
- Cuts up to 600 holes in wood without needing to be re-sharpened
- Storage space for additional hole cutters



7-PC BIG HAWG® KIT

Comes with:

- Three (3) hole cutters: 2 1/8", 2 9/16", 3 5/8"
- One (1) arbor with pilot bit
- Two (2) pilot bits
- One (1) diamond file
- One (1) hex wrench and impact resistant case

Model No. TBO277
Price/Each \$202.00



10-PC BIG HAWG® KIT

Comes with:

- Six (6) hole cutters: 2 1/8", 2 1/4", 2 9/16", 3", 3 5/8", 4 1/4"
- One (1) arbor with pilot bit
- Two (2) pilot bits
- One (1) diamond file
- One (1) hex wrench and impact resistant case

Model No. TBO278
Price/Each \$355.00



CUTTER, CORE & DRILL BITS

ICE HARDENED™ & CARBIDE TIPPED HOLE SAWS

ICE HARDENED™ HOLE SAWS

Utilize a proprietary cryogenic hardening process that improves upon traditional heat treat processes. Unlike surface coatings that wear away, cryogenics harden to the core by minimizing soft metal (austenite) and creating more hard metal (martensite).

Feature and benefits:

- Ice Hardened™ for up to 50% longer life than the competition
- Optimized tooth form for up to 2x faster cutting
- Functional slots for faster plug removal
- Matrix II bi-metal teeth for greater durability



CARBIDE TIPPED 3 TEETH PER INCH HOLE SAWS

Provide longer life and faster cutting when holes are needed in ceramic tile, flake board, fibreboard, fibreglass and wood. Carbide tipped hole saws are **NOT** recommended for use on metal.

Feature and benefits:

- Carbide-tipped 3 teeth per inch design
- Sturdy 3/16" thick steel back



| ICE HARDENED™ | | | CARBIDE TIPPED | | |
|------------------------|-----|--------------|----------------|--------------|----------------|
| Saw diameter Inches | mm | Model No. | Price /Each | Model No. | Price /Each |
| 5/8 | 16 | TB0108 | 11.00 | TW198 | 19.20 |
| 11/16 | 17 | TB0109 | 11.00 | - | - |
| 3/4 | 19 | TB0110 | 11.00 | TW199 | 19.20 |
| 13/16 | 21 | TB0111 | 11.00 | - | - |
| 7/8 | 22 | TB0112 | 11.00 | TW200 | 19.60 |
| 15/16 | 24 | TB0113 | 11.00 | - | - |
| 1 | 25 | TB0114 | 11.10 | TW201 | 19.60 |
| 1 1/16 | 27 | TB0115 | 11.10 | - | - |
| 1 1/8 | 29 | TB0116 | 11.10 | TW202 | 19.60 |
| 1 3/16 | 30 | TB0117 | 11.10 | - | - |
| 1 1/4 | 32 | TB0118 | 11.10 | TW203 | 21.50 |
| 1 5/16 | 33 | TB0119 | 11.10 | - | - |
| 1 3/8 | 35 | TB0120 | 11.70 | TW204 | 23.30 |
| 1 7/16 | 37 | TB0121 | 11.70 | - | - |
| 1 1/2 | 38 | TB0122 | 11.70 | TW205 | 25.00 |
| 1 9/16 | 40 | TB0123 | 11.70 | - | - |
| 1 5/8 | 41 | TB0124 | 11.70 | TW206 | 25.00 |
| 1 11/16 | 43 | TB0125 | 11.70 | - | - |
| 1 3/4 | 44 | TB0126 | 14.70 | TW207 | 28.70 |
| 1 13/16 | 46 | TB0127 | 14.70 | - | - |
| 1 7/8 | 48 | TB0128 | 14.70 | TW208 | 28.70 |
| 2 | 51 | TB0129 | 14.70 | TW209 | 32.30 |
| 2 1/16 | 52 | TB0130 | 17.50 | - | - |
| 2 1/8 | 54 | TB0131 | 17.50 | TW210 | 32.30 |
| 2 1/4 | 57 | TB0132 | 17.50 | TW211 | 33.80 |
| 2 5/16 | 59 | TB0133 | 17.50 | - | - |
| 2 3/8 | 60 | TB0134 | 17.50 | TW212 | 33.80 |
| 2 1/2 | 64 | TB0135 | 19.30 | TW213 | 37.50 |
| 2 9/16 | 65 | TB0136 | 19.30 | - | - |
| 2 5/8 | 67 | TB0137 | 19.30 | TW214 | 39.40 |
| 2 3/4 | 70 | TB0138 | 19.30 | TW215 | 39.40 |
| 2 7/8 | 73 | TB0139 | 19.60 | TW216 | 39.40 |
| 3 | 76 | TB0140 | 20.50 | TW217 | 39.40 |
| 3 1/8 | 79 | TB0141 | 20.50 | - | - |
| 3 1/4 | 83 | TB0142 | 20.50 | TW218 | 43.00 |
| 3 3/8 | 86 | TB0143 | 20.50 | - | - |
| 3 1/2 | 89 | TB0144 | 22.00 | TW219 | 43.00 |
| 3 5/8 | 92 | TB0145 | 24.20 | - | - |
| 3 3/4 | 95 | TB0146 | 27.50 | TW220 | 46.70 |
| 3 7/8 | 98 | TB0147 | 28.60 | - | - |
| 4 | 102 | TB0148 | 30.30 | TW221 | 53.70 |
| 4 1/8 | 105 | TB0149 | 32.40 | - | - |
| 4 1/4 | 108 | TB0150 | 42.90 | TW222 | 68.10 |
| 4 3/8 | 111 | TB0151 | 50.60 | - | - |
| 4 1/2 | 114 | TB0152 | 59.50 | TW223 | 85.80 |
| 4 3/4 | 121 | TB0153 | 66.10 | - | - |
| 5 | 127 | TB0154 | 73.40 | TW224 | 107.00 |
| 5 1/2 | 140 | TB0155 | 88.00 | - | - |
| 6 | 152 | TB0156 | 102.80 | TW225 | 129.00 |

HOLE SAW ARBORS & PILOT DRILLS

Features and benefits:

- **Quick Change VH072:** Backing plate equipped with push pins which lock into holes on the backing plate of the hole saw for positive efficient transmission of torque



VH067



VH070



VH072



| Model No. | For Hole Saw Diameter" | Shank" Thread" | Will Fit Chuck Size" | Standard Pilot Included General Purpose (Wood and Metal) | Can Also be Used with 1/4" Carbide Pilot | Price /Each | |
|-----------|------------------------|----------------|----------------------|--|--|-------------|-------|
| VH067 | 9/16 to 1 3/16 | 1/4 round | 1/2 - 20 | 1/4 and larger | TW229 | TW233 | 10.03 |
| VH070 | 9/16 to 1 3/16 | 7/16 hex | 1/2 - 20 | 1/2 and larger | TW229 | TW233 | 14.10 |
| VH071 | 9/16 to 1 3/16 | 3/8 hex | 1/2 - 20 | 3/8 and larger | TW232 | - | 12.90 |
| VH072 | 1 1/4 and + | 7/16 hex | 5/8 - 18 | 1/2 and larger | TW229 | TW233 | 28.10 |

Can't find what you're looking for?

Call us today!

CUTTER, CORE & DRILL BITS

QUIK-LOK™ FLAT BORING SETS

- 1/4" Quick-change hex shank provides quick and easy accessory changes
- Double wing spurs for easy hole formation and reduced vibration, preventing "break out"
- Patented cutting edge for easier and faster wood boring and fast chip removal which dissipates heat from the bit
- Includes: 6" universal Quik-Lok™ bit extension, 3/8", 1/2", 5/8", 3/4", 7/8", and 1 1/8" spade bits

Model No. TBO612
Price/Each \$39.70



Milwaukee

4-PIECE AUGER SETS

- Double wing spurs for clean hole cutting
- Non-stick coated flutes for faster chip ejection
- Impact rated shank
- Canvas roll-up pouch for easy storage and job site organization
- Includes: 1/2" auger bit, 3/4" auger bit, 7/8" auger bit, 1" auger bit

Model No. TBO615
Price/Each \$68.80



Milwaukee

6" SPEEDBOR FLAT BITS

- Blue-Groove point and cutting edge for faster chip removal, 4x faster than standard spade bits
- Double cutting spurs scribe the outside of the hole reducing breakout
- 10% larger shank for added durability
- Grooved hex shank prevents slipping in drill chuck or bit extension
- Fits all standard quick change chucks

| Diameter" | Shank Length" | Shank Size" | Model No. | Price /Each |
|-----------|---------------|-------------|-----------|-------------|
| 1/4 | 6 | 1/4 | TU937 | 4.50 |
| 5/16 | 6 | 1/4 | TU938 | 4.50 |
| 3/8 | 6 | 1/4 | TU939 | 4.56 |
| 7/16 | 6 | 1/4 | TU940 | 4.56 |
| 1/2 | 6 | 1/4 | TU941 | 4.56 |
| 9/16 | 6 | 1/4 | TU942 | 4.77 |
| 5/8 | 6 | 1/4 | TU943 | 5.02 |
| 11/16 | 6 | 1/4 | TU944 | 5.02 |
| 3/4 | 6 | 1/4 | TQ628 | 5.02 |
| 13/16 | 6 | 1/4 | TQ629 | 5.27 |
| 7/8 | 6 | 1/4 | TQ630 | 5.27 |
| 15/16 | 6 | 1/4 | TQ631 | 5.54 |
| 1 | 6 | 1/4 | TQ632 | 5.54 |
| 1 1/8 | 6 | 1/4 | TQ633 | 8.00 |
| 1 1/4 | 6 | 1/4 | TQ634 | 8.00 |
| 1 3/8 | 6 | 1/4 | TQ635 | 8.00 |
| 1 1/2 | 6 | 1/4 | TQ636 | 8.00 |

IRWIN
Industrial Tools



POWER DRILL LONG SHIP AUGER BITS

- Hollow centre flutes clear chips quickly out of holes
- Single cutter and side lip effortlessly bores holes in wood, cuts through nails without damaging the bit
- Full-length heat treatment guards against bending in heavy-duty applications and strengthens the twist where the greatest strain occurs
- Medium-fast screw point ideal for general wood boring applications
- Bit can be resharpened

IRWIN
Industrial Tools



| Diameter" | Shank Size" | Twist Length" | Overall Length" | Model No. | Price /Each |
|-----------|-------------|---------------|-----------------|-----------|-------------|
| 3/8 | 5/16 hex | 12 | 17 | TH663 | 38.90 |
| 7/16 | 5/16 hex | 12 | 17 | TH664 | 39.60 |
| 1/2 | 5/16 hex | 12 | 17 | TH665 | 39.90 |
| 9/16 | 7/16 hex | 12 | 17 | TH666 | 42.10 |
| 5/8 | 7/16 hex | 12 | 17 | TH667 | 42.90 |
| 11/16 | 7/16 hex | 12 | 17 | TH668 | 46.60 |
| 3/4 | 7/16 hex | 12 | 17 | TH669 | 48.10 |
| 13/16 | 7/16 hex | 12 | 17 | TH670 | 50.40 |
| 7/8 | 7/16 hex | 12 | 17 | TH671 | 53.60 |
| 15/16 | 7/16 hex | 12 | 17 | TQ661 | 54.90 |
| 1 | 7/16 hex | 12 | 17 | TH673 | 57.30 |
| 1 1/8 | 7/16 hex | 12 | 17 | TH674 | 69.90 |
| 1 1/4 | 7/16 hex | 12 | 17 | TH675 | 81.40 |
| 1 3/8 | 7/16 hex | 12 | 17 | TH676 | 93.20 |
| 1 1/2 | 7/16 hex | 12 | 17 | TH677 | 98.40 |

SWITCHBLADE™ SELF-FEED BITS

- This innovative replaceable blade system provides maximum productivity by eliminating downtime and the cost to resharpen
- Designed for drilling holes in all types of wood for pipe, vents, gas lines, and bulk wire routing
- Aggressive feed screw design allows the bit to pull through the wood faster, resulting in faster drilling
- Replacement blades made with hardened steel increases bit life
- Size and model number engraved on each bit

1 3/8" Switchblade™ Self-Feed Bits come with:

- 1 3/8" Switchblade™ self-feed bit
- 2 replaceable blades
- 2 feed screws
- 2 set screws
- One (1) hex wrench



Milwaukee

REPLACEMENT PACKS

| Dim" | Model No. | Price /Each | 3 Blades | | 10 Blades | |
|--------|-----------|-------------|-----------|-------------|-----------|-------------|
| | | | Model No. | Price /Each | Model No. | Price /Each |
| 1 3/8 | TB0301 | 65.20 | TB0306 | 24.80 | TB0311 | 64.20 |
| 1 1/2 | TB0302 | 65.20 | TB0307 | 25.50 | TB0312 | 65.60 |
| 2 | TB0303 | 77.00 | TB0308 | 26.20 | TB0313 | 68.40 |
| 2 1/8 | TB0304 | 77.00 | TB0309 | 27.60 | TB0314 | 70.40 |
| 2 9/16 | TB0305 | 84.70 | TB0310 | 29.00 | TB0315 | 73.20 |

POWER DRILL I-100 AUGER BITS

- Solid centre design provides extra rigidity while boring
- The flutes are ground behind the lands to funnel chips to the inside of the bit and away from the outside diameter, producing a faster, cleaner cut
- Single-spur cutting edge scribes the circumference of the hole for a smoother finish
- Full-length heat treated bit guards against bending in heavy-duty applications and strengthens the twist where the greatest strain occurs
- Coarse screw point provides fast boring in hard and soft woods



IRWIN
Industrial Tools

| Diameter" | Shank Size" | Twist Length" | Overall Length" | Model No. | Price /Each |
|-----------|-------------|---------------|-----------------|-----------|-------------|
| 1/4 | 7/32 hex | 4 1/2 | 7 1/2 | TH785 | 17.50 |
| 5/16 | 7/32 hex | 4 1/2 | 7 1/2 | TH786 | 17.50 |
| 3/8 | 7/32 hex | 4 1/2 | 7 1/2 | TH787 | 17.60 |
| 7/16 | 7/32 hex | 4 1/2 | 7 1/2 | TH788 | 17.60 |
| 1/2 | 7/32 hex | 4 1/2 | 7 1/2 | TH789 | 17.70 |
| 9/16 | 5/16 hex | 4 1/2 | 7 1/2 | TH790 | 17.70 |
| 5/8 | 5/16 hex | 4 1/2 | 7 1/2 | TH791 | 17.80 |
| 11/16 | 5/16 hex | 4 1/2 | 7 1/2 | TH792 | 18.40 |
| 3/4 | 5/16 hex | 4 1/2 | 7 1/2 | TH793 | 19.20 |
| 13/16 | 5/16 hex | 4 1/2 | 7 1/2 | TH794 | 21.20 |
| 7/8 | 5/16 hex | 4 1/2 | 7 1/2 | TH795 | 21.90 |
| 15/16 | 5/16 hex | 4 1/2 | 7 1/2 | TH796 | 22.90 |
| 1 | 5/16 hex | 4 1/2 | 7 1/2 | TH797 | 23.60 |

CUTTER, CORE & DRILL BITS



WOODPECKER FORSTNER BITS

- Designed to bore clean, flat, precise holes in a variety of woods
- Made of high carbon steel
- Up to 1" diameter are made with 1/4" hex shank
- Over 1" diameter made with 5/16" or 7/16" hex shank to prevent slippage

| Model No. | Diameter" | Shank" | Length" | Price /Each |
|-----------|-----------|--------|---------|-------------|
| WK611 | 1/4 | 1/4 | 3 1/2 | 3.42 |
| WK612 | 5/16 | 1/4 | 3 1/2 | 3.65 |
| WK613 | 3/8 | 1/4 | 3 1/2 | 3.86 |
| WK614 | 7/16 | 1/4 | 3 1/2 | 4.02 |
| WK615 | 1/2 | 1/4 | 3 1/2 | 4.11 |
| WK616 | 9/16 | 1/4 | 3 1/2 | 4.33 |
| WK617 | 5/8 | 1/4 | 3 1/2 | 4.56 |
| WK618 | 11/16 | 1/4 | 3 1/2 | 4.67 |
| WK619 | 3/4 | 1/4 | 3 1/2 | 4.79 |
| WK620 | 13/16 | 1/4 | 3 1/2 | 5.00 |
| WK621 | 7/8 | 1/4 | 3 1/2 | 5.25 |
| WK622 | 15/16 | 1/4 | 3 1/2 | 5.49 |
| WK623 | 1 | 1/4 | 3 1/2 | 5.70 |
| WK624 | 1 1/16 | 5/16 | 3 1/2 | 5.93 |
| WK625 | 1 1/8 | 5/16 | 3 1/2 | 6.16 |
| WK626 | 1 3/16 | 5/16 | 3 1/2 | 6.39 |
| WK627 | 1 1/4 | 5/16 | 3 1/2 | 6.39 |
| WK628 | 1 5/16 | 5/16 | 3 1/2 | 6.51 |
| WK629 | 1 3/8 | 5/16 | 3 1/2 | 6.74 |
| WK630 | 1 7/16 | 5/16 | 3 1/2 | 7.07 |
| WK631 | 1 1/2 | 5/16 | 3 1/2 | 7.28 |
| WK632 | 1 9/16 | 5/16 | 3 1/2 | 7.53 |
| WK633 | 1 5/8 | 5/16 | 3 1/2 | 7.88 |
| WK634 | 1 11/16 | 5/16 | 3 1/2 | 8.09 |
| WK635 | 1 3/4 | 5/16 | 3 1/2 | 8.42 |
| WK636 | 1 13/16 | 5/16 | 3 1/2 | 8.90 |
| WK637 | 1 7/8 | 5/16 | 3 1/2 | 9.23 |
| WK638 | 1 15/16 | 5/16 | 3 1/2 | 9.58 |
| WK639 | 2 | 5/16 | 3 1/2 | 10.00 |
| WK640 | 2 1/16 | 5/16 | 3 1/2 | 10.30 |
| WK641 | 2 1/8 | 5/16 | 3 1/2 | 10.70 |



WK664



KITS IN A WOODEN BOX

7-Pieces including: 1/4", 3/8", 1/2", 5/8", 3/4, 7/8", 1"

Model No. WK664
Price/Each \$32.50

16-Pieces including: 1/4", 3/8", 1/2", 5/8", 3/4, 7/8", 1", 1 1/8", 1 1/4", 1 3/8", 1 1/2", 1 5/8", 1 3/4", 1 7/8", 2", 2 1/8"

Model No. WK665
Price/Each \$110.00

29-Pieces including: 1/4", 5/16", 3/8", 7/16", 1/2", 9/16", 5/8", 3/4, 13/16", 7/8", 15/16", 1", 1 1/8", 1 1/4", 1 3/8", 1 1/2", 1 5/8", 1 3/4", 1 7/8", 2", 2 1/8", 2 1/4", 2 3/8", 2 1/2", 2 5/8", 2 3/4", 2 7/8", 3"

Model No. WK666
Price/Each \$262.00

| Model No. | Diameter" | Shank" | Length" | Price /Each |
|-----------|-----------|--------|---------|-------------|
| WK642 | 23/16 | 7/16 | 6 1/4 | 12.30 |
| WK643 | 2 1/4 | 7/16 | 6 1/4 | 14.10 |
| WK644 | 25/16 | 7/16 | 6 1/4 | 14.90 |
| WK645 | 2 3/8 | 7/16 | 6 1/4 | 15.70 |
| WK646 | 27/16 | 7/16 | 6 1/4 | 16.70 |
| WK647 | 2 1/2 | 7/16 | 6 1/4 | 17.30 |
| WK648 | 29/16 | 7/16 | 6 1/4 | 18.20 |
| WK649 | 2 5/8 | 7/16 | 6 1/4 | 18.90 |
| WK650 | 2 11/16 | 7/16 | 6 1/4 | 19.80 |
| WK651 | 2 3/4 | 7/16 | 6 1/4 | 20.40 |
| WK652 | 2 13/16 | 7/16 | 6 1/4 | 21.30 |
| WK653 | 2 7/8 | 7/16 | 6 1/4 | 22.00 |
| WK654 | 2 15/16 | 7/16 | 6 1/4 | 22.90 |
| WK655 | 3 | 7/16 | 6 1/4 | 23.60 |
| WK656 | 3 1/8 | 7/16 | 6 1/4 | 25.20 |
| WK657 | 3 1/4 | 7/16 | 6 1/4 | 29.60 |
| WK658 | 3 3/8 | 7/16 | 6 1/4 | 31.90 |
| WK659 | 3 1/2 | 7/16 | 6 1/4 | 33.00 |
| WK660 | 3 5/8 | 7/16 | 6 1/4 | 33.00 |
| WK661 | 3 3/4 | 7/16 | 6 1/4 | 33.10 |
| WK662 | 3 7/8 | 7/16 | 6 1/4 | 34.70 |
| WK663 | 4 | 7/16 | 6 1/4 | 36.20 |

BORMAX FORSTNER BITS

- Innovative new design outlasting any bit on the market
- European quality bits, made in Germany, CNC machined
- Premium tool steel construction, heat treated for durability and accuracy
- Razor sharp edge for excellent finish
- Incorporates saw tooth style and wave-form side clearance for tear free accurate holes
- Modified cutting head for reduced friction, cooler boring and reduced burning



| Model No. | Diameter" | Shank" | Length" | Price /Each |
|-----------|-----------|--------|---------|-------------|
| TB0650 | 1/2 | 5/16 | 3 1/2 | 18.90 |
| WK596 | 5/8 | 5/16 | 3 1/2 | 20.30 |
| TB0651 | 11/16 | 5/16 | 3 1/2 | 21.60 |
| WK597 | 3/4 | 5/16 | 3 1/2 | 21.60 |
| TB0652 | 13/16 | 5/16 | 3 1/2 | 23.00 |
| WK598 | 7/8 | 5/16 | 3 1/2 | 23.00 |
| TB0653 | 15/16 | 5/16 | 3 1/2 | 25.70 |
| WK599 | 1 | 5/16 | 3 1/2 | 28.40 |
| TB0654 | 1 1/16 | 5/16 | 3 1/2 | 28.40 |
| WK600 | 1 1/8 | 5/16 | 3 1/2 | 28.40 |
| TB0655 | 1 3/16 | 5/16 | 3 1/2 | 29.80 |
| WK601 | 1 1/4 | 3/8 | 3 1/2 | 32.50 |
| TB0656 | 1 5/16 | 3/8 | 3 1/2 | 40.60 |
| WK602 | 1 3/8 | 3/8 | 3 1/2 | 40.60 |
| WK603 | 1 1/2 | 3/8 | 3 1/2 | 43.30 |
| WK604 | 1 5/8 | 3/8 | 3 1/2 | 50.10 |
| WK605 | 1 3/4 | 3/8 | 3 1/2 | 59.60 |
| WK606 | 1 7/8 | 3/8 | 3 1/2 | 59.60 |
| WK607 | 2 | 3/8 | 3 1/2 | 65.00 |
| WK608 | 2 1/8 | 3/8 | 3 1/2 | 75.80 |
| TB0657 | 2 1/4 | 3/8 | 3 1/2 | 108.00 |
| TB0658 | 2 3/8 | 1/2 | 6 1/4 | 175.00 |
| TB0659 | 2 1/2 | 1/2 | 6 1/4 | 187.00 |
| TB0660 | 2 5/8 | 1/2 | 6 1/4 | 241.00 |
| TB0661 | 3 | 1/2 | 6 1/4 | 248.00 |

KITS IN A WOODEN BOX

5-Pieces including: 5/8", 3/4, 7/8", 1", 1 1/8", 1 3/8"

Model No. WK609
Price/Each \$194.00

7-Pieces including: 1/4" and 3/8" (Super Forstner bits), 1/2", 5/8", 3/4", 7/8", 1"

Model No. TB0662
Price/Each \$163.00

16-Pieces including: 1/4" and 3/8" (Super Forstner bits), 1/2", 5/8", 3/4", 7/8", 1", 1 1/8", 1 1/4", 1 3/8", 1 1/2", 1 5/8", 1 5/8", 1 3/4", 1 7/8", 2", 2 1/8"

Model No. WK610
Price/Each \$542.00

SUPER FORSTNER BITS

- European quality bits, made in Germany
- Premium steel construction
- Newly design cutter heads drill faster, cut cleaner and last longer
- **Application:** Flat



| Model No. | Diameter" | Shank" | Length" | Price /Each |
|-----------|-----------|--------|---------|-------------|
| WK667 | 1/4 | 5/16 | 3 1/2 | 14.40 |
| WK668 | 3/8 | 5/16 | 3 1/2 | 14.50 |
| WK669 | 1/2 | 5/16 | 3 1/2 | 15.30 |
| WK670 | 9/16 | 5/16 | 3 1/2 | 16.60 |
| WK671 | 5/8 | 5/16 | 3 1/2 | 16.60 |
| WK672 | 11/16 | 5/16 | 3 1/2 | 18.70 |
| WK673 | 3/4 | 5/16 | 3 1/2 | 17.90 |
| WK674 | 13/16 | 5/16 | 3 1/2 | 19.10 |
| WK675 | 7/8 | 5/16 | 3 1/2 | 19.10 |
| WK676 | 15/16 | 5/16 | 3 1/2 | 22.30 |
| WK677 | 1 | 5/16 | 3 1/2 | 22.30 |
| WK678 | 1 1/16 | 5/16 | 3 1/2 | 23.60 |
| WK679 | 1 1/8 | 5/16 | 3 1/2 | 23.80 |
| WK680 | 1 3/16 | 5/16 | 3 1/2 | 25.40 |
| WK681 | 1 1/4 | 3/8 | 3 1/2 | 27.00 |
| WK682 | 1 5/16 | 3/8 | 3 1/2 | 34.70 |
| WK683 | 1 3/8 | 3/8 | 3 1/2 | 34.70 |
| WK684 | 1 1/2 | 3/8 | 3 1/2 | 36.40 |
| WK685 | 1 5/8 | 3/8 | 3 5/8 | 42.40 |
| WK686 | 1 3/4 | 3/8 | 3 5/8 | 50.40 |
| WK687 | 1 7/8 | 3/8 | 3 5/8 | 50.70 |
| WK688 | 2 | 3/8 | 3 5/8 | 55.60 |
| WK689 | 2 1/8 | 3/8 | 3 5/8 | 64.70 |
| WK690 | 2 1/4 | 3/8 | 3 5/8 | 93.60 |

KITS IN A WOODEN BOX

7-Pieces including: 1/4", 3/8", 1/2", 5/8", 3/4, 7/8", 1"

Model No. WK721
Price/Each \$140.00

9-Pieces including: 1 1/8", 1 1/4", 1 3/8", 1 1/2", 1 5/8", 1 3/4", 1 7/8", 2", 2 1/8"

Model No. WK722
Price/Each \$365.00

16-Pieces including: 1/4", 3/8", 1/2", 5/8", 3/4, 7/8", 1", 1 1/8", 1 1/4", 1 3/8", 1 1/2", 1 5/8", 1 3/4", 1 7/8", 2", 2 1/8"

Model No. WK723
Price/Each \$497.00

HIGH PERFORMANCE SUPER SAWZALL® BLADES

Matrix II high speed steel teeth with 8% cobalt. Tough bi-metal design for the fastest cutting, longest blade life available. 1/2" universal tang.

ICE HARDENED™ SAWZALL® BLADE FOR METAL

- Cryogenically treated to minimize soft metal (austenite) and create more hard metal (martensite) for up to 50% longer life than standard blades
- Combination of relief angles forms a radius on the back of the tooth that reduces stress build-up and extends blade life
- Precision forming process creates sharper teeth for fast cutting
- Matrix II bi-metal teeth for greater durability

ICE HARDENED™ THE TORCH® SAWZALL® BLADE FOR METAL

- All the features of Ice Hardened™ Sawzall® blade for metal, plus:
- Precision forming process creates sharper teeth for fast cutting
- A thicker, more rigid blade body resists fracturing and bending for maximum durability
- The 1" tall blade body reduces blade twisting for straighter, more accurate cuts



| Dimensions | | | TPI | Recommended for Cutting | Pack of 5 Model No. | Price /Each |
|--|--|--|-------|--|---------------------|-------------|
| L" x W" x Thick" | | | | | | |
| WOOD CUTTING BLADES | | | | | | |
| 6 x 3/4 x 0.050 | | | 6 | Very fast cutting nail embedded wood and | TW181 | 23.40 |
| 9 x 3/4 x 0.050 | | | 6 | general roughing in | TW182 | 30.70 |
| 12 x 3/4 x 0.050 | | | 6 | | TW183 | 34.80 |
| WOOD, NAIL EMBEDDED WOOD & DEMOLITION | | | | | | |
| 6 x 1.0 x 0.062 | | | 5 | Plunge cutting | TW185 | 26.30 |
| 9 x 1.0 x 0.062 | | | 5 | Demolition work | TW186 | 34.90 |
| 12 x 1.0 x 0.062 | | | 5 | Long demolition blade | TW187 | 40.10 |
| PLASTER CUTTING BLADE | | | | | | |
| 5 x 3/4 x 0.050 | | | 6 | Cuts forward and backward stroke | TW188 | 17.30 |
| METAL CUTTING BLADES | | | | | | |
| 6 x 3/4 x 0.035 | | | 14 | Metal 3/16" thru 1/4" | TW189 | 19.60 |
| 6 x 3/4 x 0.035 | | | 18 | Metal 1/8" thru 3/16" | TW190 | 19.60 |
| 9 x 3/4 x 0.035 | | | 18 | Metal 1/8" thru 3/16" | TW191 | 24.10 |
| 6 x 3/4 x 0.035 | | | 24 | Metal thinner than 1/8" | TW192 | 19.60 |
| 4 x 3/4 x 0.035 | | | 14 | Metal 3/16" thru 1/4" | TE533 | 14.30 |
| 9 x 3/4 x 0.035 | | | 14 | Metal 3/16" thru 1/4" | TE534 | 24.10 |
| 12 x 3/4 x 0.035 | | | 18 | Metal 1/8" thru 3/16" | TE535 | 30.10 |
| ALL PURPOSE BLADES | | | | | | |
| 6 x 3/4 x 0.050 | | | 8 1/2 | All Woods, Nail Embedded | TW193 | 19.60 |
| 8 x 3/4 x 0.050 | | | 8 1/2 | Composition Material, Plastic | TW194 | 25.20 |
| 12 x 3/4 x 0.050 | | | 8 1/2 | Non-Ferrous Metals, Cast Iron | TW195 | 38.30 |

| ICE HARDENED™ THE TORCH® SAWZALL® BLADE FOR METAL | | | | | | |
|---|--|--|----|--|--------|-------|
| 6 x 1 x 0.042 | | | 10 | | TB0316 | 33.40 |
| 6 x 1 x 0.042 | | | 14 | | TB0320 | 33.40 |
| 6 x 1 x 0.042 | | | 18 | | TB0324 | 33.40 |
| 9 x 1 x 0.042 | | | 14 | | TB0336 | 44.50 |
| 9 x 1 x 0.042 | | | 18 | | TB0340 | 44.50 |

| ICE HARDENED™ SAWZALL® BLADE FOR METAL | | | | | | |
|--|--|--|------|--|--------|-------|
| 6 x 3/4 x 0.042 | | | 14 | | TB0318 | 25.20 |
| 6 x 3/4 x 0.042 | | | 18 | | TB0322 | 25.20 |
| 6 x 3/4 x 0.042 | | | 24 | | TB0326 | 25.20 |
| 6 x 3/4 x 0.042 | | | 8-12 | | TB0328 | 25.20 |
| 6 x 3/4 x 0.042 | | | 8-12 | | TB0330 | 32.20 |
| 9 x 3/4 x 0.042 | | | 14 | | TB0334 | 30.80 |
| 9 x 3/4 x 0.042 | | | 18 | | TB0338 | 30.80 |

| Dimensions | | | Type Grit | Recommended for Cutting | Pack of 3 Model No. | Price /Each |
|--------------------------------|--|--|-----------|--|---------------------|-------------|
| L" x W" x Thick" | | | | | | |
| TUNGSTEN CARBIDE BLADES | | | | | | |
| 6 x 3/4 x 0.030 | | | Coarse | fibreglass, ceramic tile, stone brick, | TW197 | 26.50 |
| 9 x 3/4 x 0.039 | | | Coarse | plaster and marble | TE536 | 34.10 |

DIAMOND GRIT THE TORCH™ SAWZALL® BLADES

Features and benefits:

- D6A steel body, durable 1" tall profile for straighter and cleaner cuts
- Featuring industrial diamond grit embedded in high strength nickel
- Blades last up to 30x longer and cut 2x faster than traditional carbide grit blades

| Dimensions | | | Type Grit | Recommended for Cutting | Model No. | Price /Each |
|------------------|--|--|----------------|---|-----------|-------------|
| L" x W" x Thick" | | | | | | |
| 6 x 1 x 0.042 | | | Diamond coarse | Cast iron, hard tile (grade 5), ceramic tile, plaster, | TB0299 | 20.60 |
| 9 x 1 x 0.042 | | | Diamond coarse | masonry, brick, fibreglass and other abrasive materials | TB0300 | 25.00 |



Wood Cutting Blade



Wood, Nail Embedded Wood and Demolition



Plaster Cutting Blade



Metal Cutting Blade



All Purpose Blade



Ice Hardened™ The Torch® Sawzall® Blade for metal



Ice Hardened™ Sawzall® Blade for metal



Tungsten Carbide Blade

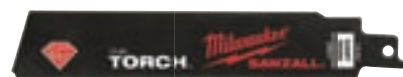

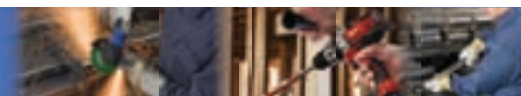

WHAT YOU SHOULD KNOW ABOUT CIRCULAR SAW BLADES

Tooth design is the determining factor in deciding which blade is best for which industrial application. Here's a quick overview of how subtle changes in bevel, gullet and kerf affect cutting performance.

freud

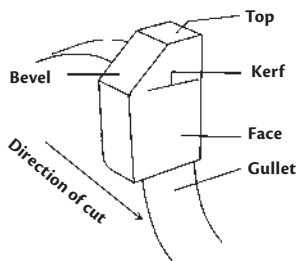

BEVEL

Teeth can have a single bevel, two bevels or no bevel at all. Types of bevels can alternate from tooth to tooth on a given blade. The bevel is what gives the blade its specific cutting pattern.

GULLET

This is the space between teeth that clears the work piece of chips after the cut. The deeper the gullet, the more efficiently chips are cleared.

KERF

This is the face of the tooth, where the actual cutting takes place. The pattern of alternating kerfs, known as the grind, decides what applications a blade is best for.

GRIND

There are many types of grinds, but the five basic ones are:

Flat top grind (FTG) - best for ripping.

Alternate top bevel (ATB) - for crosscutting, cut-off and trimming.

Triple chip grind (TCG) - perfect for hard, abrasive materials like non-ferrous metals, hardwoods and plastics.

Multi-purpose carbide tipped (MCT) or ripping and crosscutting, mitre.

Tri-grind (TRI) - combination grind.



INDUSTRIAL BLADES

TCS

Feature Freud's newest and most resilient PermaShield® coating. This blade now combines Freud's highest quality blade with its highest quality coating. The TCS coating helps reduce blade distorting heat and makes cutting a breeze.

freud

GENERAL PURPOSE

- Crosscut and cutoff of hard and soft woods

| Model No. | Mfg. No. | Blade Dia.™ | Arbor™ | No. of Teeth | Kerf™ | Degrees | Hook Grind | Price /Each |
|-----------|----------|-------------|--------|--------------|-------|---------|------------|-------------|
| TT815 | LU84R008 | 8 | 5/8 | 40 | 0.126 | 10 | MCT | 103.00 |
| TT817 | LU84R010 | 10 | 5/8 | 50 | 0.126 | 10 | MCT | 88.98 |
| TT818 | LU84R012 | 12 | 1 | 60 | 0.126 | 10 | MCT | 163.00 |

SLIDING COMPOUND MITER BLADES

- Easy fast cutting

| Model No. | Mfg. No. | Blade Dia.™ | Arbor™ | No. of Teeth | Kerf™ | Degrees | Hook Grind | Price /Each |
|-----------|----------|-------------|--------|--------------|-------|---------|------------|-------------|
| TT833 | LU91R008 | 8 | 5/8 | 48 | 0.090 | -5 | ATB | 94.83 |
| TT834 | LU91R010 | 10 | 5/8 | 60 | 0.090 | -5 | TCG | 117.00 |

RIPPING

- Rips hard and soft woods

| Model No. | Mfg. No. | Blade Dia.™ | Arbor™ | No. of Teeth | Kerf™ | Degrees | Hook Grind | Price /Each |
|-----------|----------|-------------|--------|--------------|-------|---------|------------|-------------|
| TT809 | LM72R008 | 8 | 5/8 | 24 | 0.126 | 20 | FTG | 83.00 |
| TT810 | LM72R010 | 10 | 5/8 | 24 | 0.126 | 20 | FTG | 93.48 |
| TT811 | LM72R012 | 12 | 1 | 30 | 0.169 | 20 | FTG | 125.00 |

CROSSCUT & FINISHING

- Ultra smooth crosscut and mitres

| Model No. | Mfg. No. | Blade Dia.™ | Arbor™ | No. of Teeth | Kerf™ | Degrees | Hook Grind | Price /Each |
|-----------|----------|-------------|--------|--------------|-------|---------|------------|-------------|
| TT821 | LU85R008 | 8 | 5/8 | 64 | 0.116 | 10 | ATB | 112.00 |
| TT823 | LU85R010 | 10 | 5/8 | 80 | 0.116 | 10 | ATB | 126.00 |
| TT824 | LU85R012 | 12 | 1 | 96 | 0.116 | 10 | ATB | 218.00 |

LAMINATE & CHIPBOARD

- Cuts dense abrasive man-made materials

| Model No. | Mfg. No. | Blade Dia.™ | Arbor™ | No. of Teeth | Kerf™ | Degrees | Hook Grind | Price /Each |
|-----------|----------|-------------|--------|--------------|-------|---------|------------|-------------|
| TT836 | LU98R008 | 8 | 5/8 | 64 | 0.126 | -10 | TCG | 138.00 |
| TT838 | LU98R010 | 10 | 5/8 | 80 | 0.126 | -10 | TCG | 135.00 |
| TT839 | LU98R012 | 12 | 1 | 96 | 0.126 | -10 | TCG | 191.00 |

PREMIER FUSION GENERAL PURPOSE SAW BLADES

- Rips woods, crosscuts wood, plywood, laminate

freud

| Model No. | Mfg. No. | Blade Dia.™ | Arbor™ | No. of Teeth | Kerf™ | Hook Grind | Price /Each |
|-----------|----------|-------------|--------|--------------|-------|------------|-------------|
| TB0352 | P408 | 8 | 5/8 | 34 Hi | 0.126 | ATB | 119.00 |
| TB0353 | P410 | 10 | 5/8 | 40 Hi | 0.126 | ATB | 124.00 |
| TB0354 | P412 | 12 | 1 | 48 Hi | 0.126 | ATB | 159.00 |

HEAVY-DUTY GLUE LINE RIPPING BLADES

- Rips wood, crosscuts wood, chip board, plywood, laminate

freud

| Model No. | Mfg. No. | Blade Dia.™ | Arbor™ | No. of Teeth | Kerf™ | Hook Grind | Price /Each |
|-----------|----------|-------------|--------|--------------|-------|------------|-------------|
| TB0357 | LM74R010 | 10 | 5/8 | 30 | 0.118 | TCG | 92.03 |
| TB0358 | LM74R012 | 12 | 1 | 40 | 0.118 | TCG | 117.00 |
| TB0359 | LM74R014 | 14 | 1 | 44 | 0.138 | TCG | 133.00 |

MITRE CROSSCUT

- Crosscut and mitre of hard and soft woods

freud

| Model No. | Mfg. No. | Blade Dia.™ | Arbor™ | No. of Teeth | Kerf™ | Degrees | Hook Grind | Price /Each |
|-----------|----------|-------------|--------|--------------|-------|---------|------------|-------------|
| TT684 | LU73M010 | 10 | 5/8 | 60 | 0.126 | 10 | ATB | 100.00 |
| TT685 | LU73M012 | 12 | 1 | 72 | 0.126 | 10 | ATB | 148.00 |
| TT686 | LU73M014 | 14 | 1 | 84 | 0.138 | 10 | ATB | 180.00 |

GENERAL PURPOSE SAW BLADES

- For crosscutting thick hardwoods and softwoods (3/4" to 3 1/2") and thinner stock material (1/4" to 1")
- Anti-vibration design, Silver Ice™ coating

freud

| Model No. | Mfg. No. | Blade Dia.™ | Arbor™ | No. of Teeth | Kerf™ | Degrees | Hook Grind | Price /Each |
|-----------|----------|-------------|--------|--------------|-------|---------|------------|-------------|
| TT639 | LU72M014 | 14 | 1 | 54 | 0.138 | 13 | ATB | 145.00 |

DOUBLE SIDED LAMINATE/MELAMINE

- Rips wood, crosscuts wood, chip board, plywood, melamine, laminate

freud

| Model No. | Mfg. No. | Blade Dia.™ | Arbor™ | No. of Teeth | Kerf™ | Hook Grind | Price /Each |
|-----------|----------|-------------|--------|--------------|-------|------------|-------------|
| TB0360 | LM97R008 | 8 | 5/8 | 64 | 0.126 | TCG | 107.00 |
| TB0361 | LM97R010 | 10 | 5/8 | 80 | 0.126 | TCG | 128.00 |
| TB0362 | LM97R012 | 12 | 1 | 96 | 0.126 | TCG | 164.00 |
| TB0363 | LM97R014 | 14 | 1 | 108 | 0.138 | TCG | 162.00 |

CONTRACTOR SAW BLADES

DIABLO® SAW BLADES

- Thin kerf, ideal for portable and low powered saws
- Perma-Shield® coating, keeps the blades resistant to gumming and corrosion
- Laser-cut stabilizer vents reduces vibration and heat built up

freud®

Combination

- For ripping and crosscutting

| Model No. | Mfg. No. | Blade Dia." | Arbor" | No. of Teeth | Hook Grind | Price /Each |
|-----------|----------|-------------|--------|--------------|------------|-------------|
| TDX905 | D1050X | 10 | 5/8 | 50 | ATB | 65.64 |

Finishing

- For ripping, crosscutting, decking, fencing and plywood

| Model No. | Mfg. No. | Blade Dia." | Arbor" | No. of Teeth | Hook Grind | Price /Each |
|-----------|----------|-------------|--------|--------------|------------|-------------|
| TDX992 | D0740A | 7 1/4 | 5/8 | 40 | ATB | 25.13 |
| TEX006 | D0840X | 8 1/2 | 5/8 | 40 | ATB | 30.95 |

Fine Finishing

- For crosscutting oak, pine, melamine, plywood and molding, very smooth finish

| Model No. | Mfg. No. | Blade Dia." | Arbor" | No. of Teeth | Hook Grind | Price /Each |
|-----------|----------|-------------|--------|--------------|------------|-------------|
| TEX005 | D0860S | 8 1/2 | 5/8 | 60 | ATB | 69.24 |
| TDX909 | D1060S | 10 | 5/8 | 60 | ATB | 76.51 |
| TDX931 | D1280X | 12 | 1 | 80 | ATB | 87.95 |

General Purpose

- For cutting oak, pine, plywood, pressure treated lumber and beams

| Model No. | Mfg. No. | Blade Dia." | Arbor" | No. of Teeth | Hook Grind | Price /Each |
|-----------|----------|-------------|--------|--------------|------------|-------------|
| TDX901 | D1040X | 10 | 5/8 | 40 | ATB | 53.17 |
| TDX926 | D1244X | 12 | 1 | 44 | ATB | 53.94 |

METAL CUTTING SAW BLADE

- For cutting ferrous metals up to 25 HRC, aluminum, wood and composite material

DIMAR

| Model No. | Mfg. No. | Blade Dia." | Arbor" | No. of Teeth | Kerf | Price /Each |
|-----------|-----------|-------------|--------|--------------|-------|-------------|
| TB0728 | 8-40 MET | 8 | 5/8 | 40 | 0.086 | 94.20 |
| TB0729 | 10-48 MET | 10 | 1 | 48 | 0.094 | 94.20 |
| TRW236 | 12-60 MET | 12 | 1 | 60 | 0.094 | 141.00 |
| TRW240 | 12-80 MET | 12 | 1 | 80 | 0.094 | 166.00 |
| TB0730 | 14-90 MET | 14 | 1 | 90 | 0.1 | 204.00 |

SAWS FOR NON-FERROUS METAL

- Material must be clamped firmly to the table on both sides during cutting operation and the use of coolant is very important

DIMAR

| Model No. | Mfg. No. | Blade Dia." | Arbor" | No. of Teeth | Kerf" | Degrees | Hook Grind | Price /Each |
|-----------|--------------|-------------|--------|--------------|-------|---------|------------|-------------|
| TRW242 | 6 1/4-48 N/F | 6 1/4 | 5/8 | 48 | 0.113 | -6 | TCG | 96.80 |
| TRW244 | 7 1/4-58 N/F | 7 1/4 | 5/8 | 58 | 0.113 | -6 | TCG | 104.00 |
| TRW114 | 8-48 N/F | 8 | 5/8 | 48 | 0.113 | -6 | TCG | 109.00 |
| TRW245 | 8-64 N/F | 8 | 5/8 | 64 | 0.113 | -6 | TCG | 131.00 |
| TRW117 | 10-80 N/F | 10 | 5/8 | 80 | 0.126 | -6 | TCG | 164.00 |
| TRW153 | 10-100 N/F | 10 | 5/8 | 100 | 0.126 | -6 | TCG | 197.00 |
| TRW119 | 12-96 N/F | 12 | 1 | 96 | 0.126 | -6 | TCG | 202.00 |
| TRW120 | 14-84 N/F | 14 | 1 | 84 | 0.126 | -6 | TCG | 219.00 |
| TRW121 | 14-108 N/F | 14 | 1 | 108 | 0.126 | -6 | TCG | 238.00 |
| TRW163 | 15-100 N/F | 15 | 1 | 100 | 0.126 | -6 | TCG | 263.00 |

GROOVING SAW

BLADES FOR ALUMINUM

- Used for milling, clean up and grooving of aluminum welds and cutting out welding tracks
- Used with hand held grinder

DIMAR

| Model No. | Mfg. No. | Blade Dia. mm | Arbor" | No. of Teeth | Kerf" | Price /Each |
|-----------|--------------|---------------|--------|--------------|-------|-------------|
| TRW263 | 4-24 N/F | 100 | 5/8 | 24 | 0.154 | 70.30 |
| TRW264 | 4-30 N/F | 100 | 5/8 | 30 | 0.154 | 75.40 |
| TRW265 | 4 1/2-24 N/F | 115 | 5/8 | 24 | 0.154 | 75.40 |
| TRW266 | 4 1/2-30 N/F | 115 | 5/8 | 30 | 0.154 | 83.10 |

CROSSCUT & PLYWOOD

- Smooth crosscut and plywood

freud®

| Model No. | Mfg. No. | Blade Dia." | Arbor" | No. of Teeth | Hook Grind | Price /Each |
|-----------|----------|-------------|--------|--------------|------------|-------------|
| TV663 | TK303 | 7 1/4 | 5/8 | 40 | FTG | 31.31 |
| TV664 | TK304 | 8 1/4 | 5/8 | 40 | FTG | 33.99 |
| TV665 | TK306 | 10 | 5/8 | 40 | FTG | 50.95 |

SAFETY

GLOVES
TRAFFIC CONTROL
SPILL CONTROL
EYEWEAR

ZENITH®
Safety Products



aurora tools®

Aurora pneumatic tools are constructed to withstand the most demanding applications. These professional pneumatic tools are ideal for use in automotive, construction and industrial applications.

5" PNEUMATIC ANGLE GRINDERS

- Polyurethane grip reduces operator fatigue and vibration
- 5/8" x 11 UNC spindle
- Powerful twin – chamber motor-delivers much higher torque
- Side handle and wrenches included

Model No. THZ674



aurora tools®

| Model No. | Grinding Wheel | | Spindle Thread | | Free Speed RPM | Average Air Consumption CFM | | Air Inlet | Hose Size | | Vibration Less Than m/s ² | Sound Pressure Level dB(A) | Net Weight | | Price /Each |
|-----------|----------------|-----|----------------|------|----------------|-----------------------------|----|---------------|-----------|-----|--------------------------------------|----------------------------|------------|------|-------------|
| | in | mm | in | mm | | in | mm | | in | mm | | | lbs. | kg | |
| THZ674 | 5 | 127 | 5.8 | 15.9 | 10000 | 5 | | 1/4" - 18 NPT | 3/8 | 9.5 | 3.1 | 83 | 3.1 | 1.41 | 210.00 |

1/4" PNEUMATIC MINI DIE GRINDERS

- Polyurethane grip reduces operator fatigue and vibration
- Power/speed regulator allows for easy PSI adjustment
- Twin-bearing design for smooth operation
- Wrenches included

Model No. THZ678



aurora tools®

1/4" PNEUMATIC ANGLE DIE GRINDERS

- Polyurethane grip reduces operator fatigue and vibration
- Power/speed regulator allows for easy PSI adjustment
- Twin-bearing design for smooth operation
- Wrenches included

Model No. THZ679



aurora tools®

| Model No. | Collet Size | | Free Speed RPM | Average Air Consumption CFM | | Air Inlet | Hose Size | | Horsepower HP | Vibration Less Than m/s ² | Sound Pressure Level dB(A) | Net Weight | | Price /Each |
|-----------|-------------|-----|----------------|-----------------------------|----|---------------|-----------|-----|---------------|--------------------------------------|----------------------------|------------|------|-------------|
| | in | mm | | in | mm | | in | mm | | | | lbs. | kg | |
| THZ678 | 1/4 | 6.4 | 25000 | 3 | | 1/4" - 18 NPT | 3/8 | 9.5 | 0.35 | 0.1 | 83 | 0.9 | 0.43 | 78.95 |
| THZ679 | 1/4 | 6.4 | 18000 | 3 | | 1/4" - 18 NPT | 3/8 | 9.5 | 0.45 | 0.1 | 80 | 1.7 | 0.77 | 96.50 |

3" AIR CUT-OFF TOOLS

- Polyurethane handle reduces operator fatigue and vibration
- Power/speed regulator allows for easy PSI adjustment
- Twin-bearing design for smooth operation and cut off powerfully
- Wrenches included

Model No. THZ677



aurora tools®

| Model No. | Cutting Wheel | | Free Speed RPM | Average Air Consumption CFM | | Air Inlet | Hose Size | | Horsepower HP | Vibration Less Than m/s ² | Sound Pressure Level dB(A) | Net Weight | | Price /Each |
|-----------|---------------|------|----------------|-----------------------------|----|-------------|-----------|-----|---------------|--------------------------------------|----------------------------|------------|------|-------------|
| | in | mm | | in | mm | | in | mm | | | | lbs. | kg | |
| THZ677 | 3 | 76.2 | 21000 | 3 | | 1/4"-18 NPT | 3/8 | 9.5 | 0.45 | 0.2 | 81 | 1.8 | 0.82 | 71.95 |

3/8" AIR REVERSIBLE DRILLS

- Lightweight composite design minimizes operator fatigue
- Ergonomic grip reduces vibration
- Two-gear structure runs smoothly

Model No. THZ675



aurora tools

1/2" AIR REVERSIBLE DRILLS

- Lightweight composite design minimizes operator fatigue
- Ergonomic grip reduces vibration
- Two-gear structure runs smoothly
- Side handle included

Model No. THZ676



aurora tools

| Model No. | Chuck Size in mm | Spindle Thread | Free Speed RPM | Average Air Consumption CFM | Air Inlet | Hose Size in mm | Vibration Less Than m/s ² | Sound Pressure Level dB(A) | Net Weight lbs. kg | Price /Each |
|-----------|---------------------|-------------------|----------------|-----------------------------|---------------|--------------------|--------------------------------------|----------------------------|-----------------------|-------------|
| THZ675 | 3/8 9.5 | 3/8" - 24 threads | 1800 | 4 | 1/4" - 18 NPT | 3/8 9.5 | 0.10 | 88 | 2.0 0.91 | 125.00 |
| THZ676 | 1/2 12.7 | 3/8" - 24 threads | 450 | 4 | 1/4" - 18 NPT | 3/8 9.5 | 0.15 | 88 | 3.0 1.36 | 160.00 |

3/4" HEAVY-DUTY AIR IMPACT WRENCHES

- Lightweight composite design minimizes operator fatigue
- Ergonomic grip reduces vibration
- Twin hammer impact mechanism
- Three step forward/reverse regulator allows the operator to adjust the power to the job
- Rear exhaust directs air away from work piece and operator
- Special heat-treatment of major parts & anvil for long life

Model No. THZ672



aurora tools

1/2" HEAVY-DUTY AIR IMPACT WRENCHES

- Pin-clutch hammer mechanism
- Built-in regulator to prevent over-torquing
- Low noise, low vibration
- Forward-reverse switch, and high-low speed regulator
- Durability and longer life

Model No. THZ673



aurora tools

| Model No. | Square Drive in mm | Bolt Capacity in mm | Free Speed RPM | Torque Range ft.-lbs. | Average Air Consumption CFM | Air Inlet | Hose Size in mm | Vibration Less Than m/s ² | Sound Pressure Level dB(A) | Net Weight lbs. kg | Price /Each |
|-----------|-----------------------|------------------------|----------------|-----------------------|-----------------------------|---------------|--------------------|--------------------------------------|----------------------------|-----------------------|-------------|
| THZ672 | 3/4 19 | 1 25.4 | 4600 | 565-1100 | 9 | 1/4" - 18 NPT | 3/8 9.5 | 6.1 | 90 | 11.21 5.09 | 415.00 |
| THZ673 | 1/2 12.7 | 5/8 15.9 | 7000 | 25-320 | 12 | 1/4" - 18 NPT | 3/8 9.5 | 3.1 | 94 | 5 2.27 | 152.00 |

3/8" HEAVY-DUTY COMPOSITE AIR IMPACT WRENCHES

- Lightweight composite design minimizes operator fatigue
- Ergonomic grip reduces vibration
- Exhaust air outlet directs air away from operator
- Forward-reverse switch, and high-low speed regulator
- Low noise, low vibration
- Overall length: 7"
- Weight: 2.8 lbs.

Model No. TLZ137



aurora tools

1/2" HEAVY-DUTY COMPOSITE AIR IMPACT WRENCHES

- Lightweight composite design minimizes operator fatigue
- Ergonomic grip reduces vibration
- Exhaust air outlet directs air away from operator
- Forward-reverse switch, and high-low speed regulator
- Low noise, low vibration
- Overall length: 7 3/4"
- Weight: 4.6 lbs.

Model No. TLZ138



aurora tools

| Model No. | Square Drive in mm | Bolt Capacity in mm | Free Speed RPM | Torque Range ft.-lbs. | Average Air Consumption CFM | Air Inlet | Hose Size in mm | Vibrations Less Than m/s ² | Sound Pressure Level dB(A) | Price /Each |
|-----------|-----------------------|------------------------|----------------|-----------------------|-----------------------------|---------------|--------------------|---------------------------------------|----------------------------|-------------|
| TLZ137 | 3/8 9.53 | 1/2 13 | 10000 | 90-280 | 10.6 | 1/4" - 18 NPT | 3/8 9.5 | 3.7 | 91.5 | 285.00 |
| TLZ138 | 1/2 12.7 | 5/8 16 | 10000 | 400-1000 | 13.7 | 1/4" - 18 NPT | 3/8 9.5 | 6.0 | 94 | 355.00 |

AIR TOOLS

COMPOSITE 3/4" HEAVY-DUTY AIR IMPACT WRENCHES

- Lightweight composite design minimizes operator fatigue
- Ergonomic grip reduces vibration
- Exhaust air outlet directs air away from operator
- Forward-reverse switch, and high-low speed regulator
- Overall length: 8"
- Weight: 5 lbs.

Model No. TLZ139



aurora tools

| Model No. | Square Drive in mm | Bolt Capacity in mm | Free Speed RPM | Torque Range ft-lbs. | Average Air Consumption CFM | Air Inlet | Hose Size in mm | Vibrations Less Than m/s ² | Sound Pressure Level dB(A) | Price /Each |
|-----------|--------------------|---------------------|----------------|----------------------|-----------------------------|---------------|-----------------|---------------------------------------|----------------------------|-------------|
| TLZ139 | 3/4 19.1 | 1 26 | 9000 | 450-1000 | 13.7 | 1/4" - 18 NPT | 3/8 9.5 | 9.2 | 95.9 | 499.00 |

3/8" HEAVY-DUTY AIR RATCHET WRENCHES

- Lightweight aluminum design minimizes operator fatigue
- Polyurethane grip reduces vibration
- Variable speed, reversible
- Paddle style trigger provides better speed control
- Ideal for automotive and industrial fastener removal and installation work

Model No. THZ671



aurora tools

1/2" HEAVY-DUTY AIR RATCHET WRENCHES

- Lightweight aluminum design minimizes operator fatigue
- Polyurethane grip reduces vibration
- Variable speed, reversible
- Paddle style trigger provides better speed control
- Ideal for automotive and industrial fastener removal and installation work

Model No. THZ680



aurora tools

| Model No. | Square Drive Size in mm | Free Speed RPM | Torque Range ft-lbs. | Average Air Consumption CFM | Air Inlet | Hose Size in mm | Horse Power HP | Vibration Less Than m/s ² | Sound Pressure Level dB(A) | Net Weight lbs. kg | Price /Each |
|-----------|-------------------------|----------------|----------------------|-----------------------------|---------------|-----------------|----------------|--------------------------------------|----------------------------|--------------------|-------------|
| THZ671 | 3/8 9.5 | 175 | 5-75 | 3 | 1/4" - 18 NPT | 3/8 9.5 | 0.45 | 1.0 | 78 | 2.6 1.18 | 105.00 |
| THZ680 | 1/2 12.7 | 175 | 5-75 | 3 | 1/4" - 18 NPT | 3/8 9.5 | 0.45 | 1.0 | 83 | 2.6 1.18 | 120.00 |

1/4" STUBBY TYPE AIR RATCHET WRENCHES

- Lightweight aluminum design minimizes operator fatigue
- Polyurethane grip reduces vibration
- Variable speed, reversible
- Paddle style trigger provides better speed control
- Powerful tool in a compact design
- (Polyurethane handle helps insulate vibration)
- Overall length: 7 1/4"
- Weight: 1.4 lbs.

Model No. TLZ140



aurora tools

| Model No. | Square Drive in mm | Free Speed RPM | Torque Range ft-lbs. | Average Air Consumption CFM | Air Inlet | Hose Size in mm | Vibrations Less Than m/s ² | Sound Pressure Level dB(A) | Price /Each |
|-----------|--------------------|----------------|----------------------|-----------------------------|---------------|-----------------|---------------------------------------|----------------------------|-------------|
| TLZ140 | 1/4 6.35 | 230 | 5-30 | 3 | 1/4" - 18 NPT | 5/16 8 | 4.4 | 87 | 135.00 |

See pages 1262 - 1265 for Air Compressors



5" DUAL-ACTION ORBIT SANDERS

- Dual-action, compact and lightweight design
- Lever throttle offers one hand control
- Low vibration for swirl-free finishes
- Non-vacuum model
- Pad size (5"-6")
- Overall length: 6 1/2"
- Weight: 1.8 lbs.
- Stick-on pad comes standard (TLZ472)
- Optional Hook & Loop pad (TLZ473)

Model No. TLZ142



aurora tools

6" DUAL-ACTION ORBIT SANDERS

- Dual-action, compact and lightweight (ergonomic) design
- Lever throttle offers one hand control
- Low vibration for swirl-free finishes
- Non-vacuum model
- Pad size (5"-6")
- Overall length: 7"
- Weight: 1.9 lbs.
- Stick-on pad comes standard (TLZ474)
- Optional Hook & Loop pad (TLZ475)

Model No. TLZ143



aurora tools

| Model No. | Free Speed RPM | Average Air Consumption CFM | Air Inlet | Hose Size in mm | Horse Power HP | Vibrations Less Than m/s ² | Sound Pressure Level dB(A) | Price /Each |
|-----------|----------------|-----------------------------|---------------|-----------------|----------------|---------------------------------------|----------------------------|-------------|
| TLZ142 | 10 000 | 9 | 1/4" – 18 NPT | 3/8 9.5 | 0.35 | 0.80 | 78 | 226.00 |
| TLZ143 | 10 000 | 9 | 1/4" – 18 NPT | 3/8 9.5 | 0.35 | 0.80 | 78 | 226.00 |

1/4" AIR SCREWDRIVERS

- Durable steel body
- Forward-reverse switch
- Low noise, low vibrations
- Overall length: 7 1/2"
- Weight: 2.4 lbs.



aurora tools

| Model No. | Free Speed RPM | Torque Range ft.-lbs. | Average Air Consumption CFM | Air Inlet | Hose Size in mm | Horse Power HP | Vibrations Less Than m/s ² | Sound Pressure Level dB(A) | Price /Each |
|-----------|----------------|-----------------------|-----------------------------|---------------|-----------------|----------------|---------------------------------------|----------------------------|-------------|
| TLV495 | 1800 | 45-115 | 6 | 1/4" – 18 NPT | 3/8 9.5 | 0.5 | 0.7 | 82 | 148.00 |

AIR FLUX CHIPPERS & NEEDLE SCALERS

- Lightweight compact design permits increased operator efficiency
- Paddle style trigger offers better speed control and precision
- Low noise, low vibration
- Durability and longer life

TLZ133

- Overall length: 10 1/4"
- Weight: 4.1 lbs.
- Comes with 35 mm flat chisel

- **Available accessories:** TLZ134 – 20 mm flat chisel
TLZ135 – 35 mm flat chisel
TLZ136 –moil point

TLZ131

- Weight: 6.1 lbs.
- Comes with 19 needles
- Replacement needles TLZ132



aurora tools

| Model No. | Stroke in mm | Blows per minute BPM | Average Air Consumption CFM | Air Inlet | Hose Size in mm | Vibrations Less Than m/s ² | Sound Pressure Level dB(A) | Price /Each |
|-----------|--------------|----------------------|-----------------------------|---------------|-----------------|---------------------------------------|----------------------------|-------------|
| TLZ133 | 1-1/2 38 | 4400 | 9 | 1/4" – 18 NPT | 3/8 9.5 | 10.2 | 92 | 199.00 |
| TLZ131 | 1-1/2 38 | 4000 | 9 | 1/4" – 18 NPT | 3/8 9.5 | 10.2 | 104.3 | 225.00 |

AIR HOSES NYLON COIL C/W FITTING

- Light and easy to handle
- Maximum working pressure, 300 PSI
- 3/8" NPT Male threads
- High impact and abrasion resistance
- Excellent elastic memory, can be stretched repeatedly yet return to original shape for convenient storage
- Colour: High-viz yellow
- Temperature range: -5°C to 70°C



aurora tools

| Model No. | NPT (M)" | Length | Hose Inside Diameter" | Price/Each |
|-----------|----------|--------|-----------------------|------------|
| TLZ150 | 1/4 | 25' | 1/4 | 12.30 |
| TLZ151 | 1/4 | 50' | 1/4 | 19.55 |
| TLZ152 | 3/8 | 25' | 3/8 | 21.90 |
| TLZ153 | 3/8 | 50' | 3/8 | 32.65 |

PLUG QUICK COUPLER KITS, 5 PIECES

Set includes:

- One 1/4" Quick coupler
- One 1/4" Female plug
- Three 1/4" Male plugs

Model No. TLZ148

Price/Each \$16.50



aurora tools

AIR TOOLS

3/8" IMPACT WRENCHES

For general maintenance

- Twin hammer clutch
- Composite handle and magnesium clutch housing
- S2S technology allows to effortless change between forward and reverse
- Three positive power settings
- Full teasing trigger

Model No. TLV696



3/8" BUTTERFLY IMPACT WRENCHES

- Butterfly forward/reverse throttle
- Rocking dog clutch for smooth operations and durability
- Four positive power settings
- Easy maneuvering with 360° air inlet swivel
- Comfort and maneuverability
- Shank size: 3/8"
- Shank retainer type: Friction ring
- Working torque: 5-65 ft-lbs.
- Ideal for bench work, carburetors, ignitions, body panels, transmissions, oil pans and small engine repair

Model No. THZ806



3/8" IMPACT WRENCHES

General duty for maintenance/repair.

- High torque Dyna Pact™ clutch
- Ergonomic handle for excellent balance and feel
- 1/4" (NPTF) air inlet thread
- 3/8" min. hose size

Model No. THZ944



1/2" IMPACT WRENCHES

Standard duty for use in a variety of fastening operations.

- Dyna Pact™ clutch
- Built-in power regulator
- Push-through reverse mechanism

Model No. THZ946



1/2" IMPACT WRENCHES

For general duty repair/maintenance and light-to-medium assembly applications.

- Twin clutch increases ultimate torque for smooth operation under heavy loading
- Oil bath clutch
- Teasing throttle

Model No. THZ948



3/4" IMPACT WRENCHES

High ultimate torque for tough applications.

- Ideal for hard pull up conditions
- Push-through reverse mechanism
- Teasing throttle
- Oil bath clutch chamber
- Pin clutch
- 3/8" (NPTF) air inlet thread
- 3/8" min. hose size

Model No. THZ955



1" IMPACT WRENCHES

Standard duty for use in steel erection, heavy assembly/disassembly, maintenance/repair, and construction.

- Teasing throttle
- Rocking dog clutch
- Closed-grip inside trigger
- 6" extended shank
- 1/2" (NPTF) air inlet thread
- 1/2" min. hose size

Model No. TJZ370

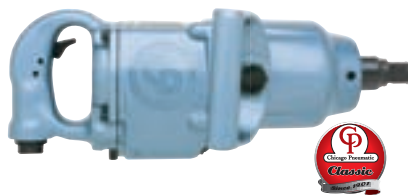

Chicago Pneumatic™

| Model No. | Mfg. No. | Shank | | | Working Torque | | Maximum Torque | | CFM | Overall Length | | Net Weight | | Price /Each |
|-----------|----------|-------|------|---------------------|----------------|----------|----------------|------|-----|----------------|-----|------------|------|-------------|
| | | Size | | Retainer Type | ft-lbs. | Nm | ft-lbs. | Nm | | in. | mm | lbs. | kg | |
| | | in. | mm | | | | | | | | | | | |
| TLV696 | CP7722 | 3/8 | 10 | Friction Ring | 50-300 | 68-407 | 415 | 563 | 20 | 6 1/2 | 163 | 2.8 | 1.3 | 343.00 |
| THZ806 | CP772 | 3/8 | 10 | Friction Ring | 5-50 | 6.8-70 | 90 | 122 | 10 | 5 3/4 | 146 | 2 | 0.9 | 227.00 |
| THZ944 | CP724H | 3/8 | 10 | Friction Ring | 20-160 | 27-217 | 200 | 272 | 12 | 6 | 152 | 3.1 | 1.4 | 269.00 |
| THZ946 | CP734H | 1/2 | 13 | Friction Ring | 25-310 | 34-420 | 425 | 576 | 15 | 7 1/2 | 191 | 5 | 2.3 | 249.00 |
| THZ948 | CP749 | 1/2 | 13 | Friction Ring | 25-330 | 34-450 | 450 | 610 | 16 | 7 1/2 | 194 | 5.5 | 2.5 | 319.00 |
| THZ955 | CP772H | 3/4 | 19 | Friction Ring | 150-700 | 200-950 | 1000 | 1360 | 24 | 9 5/8 | 244 | 10.5 | 4.8 | 659.00 |
| TJZ370 | CP797 | 1 | 25.4 | Hole for Socket Pin | 150-900 | 200-1225 | 1400 | 1900 | 40 | 15 1/2 | 394 | 27 | 12.3 | 1389.00 |

Noise levels are at 1.0 m per Pneurop Standard 8N-1. Vibration levels are per ISO 8662-1.

Standard equipment: removable dead handle. **TG063:** Socket pin and retaining ring. **TG065:** adjustable and removable dead handle, socket pin and retaining ring.

DRILLS

NON-REVERSIBLE DRILLS 1/8" TO 3/8" CAPACITY

For maintenance and general use

- 1/2 HP motor
- Light weight
- Triple idler planetary gears
- Double ball bearing supported spindle
- Teasing throttle
- 1/4" (NPTF) air inlet thread
- 3/8" min. hose size

Model No. TG070



REVERSIBLE DRILLS 1/8" TO 1/2" CAPACITY

For precision drilling, hole sawing, honing, countersinking, and reaming

- 1/2 HP reversible motor
- Variable speed
- Teasing throttle
- Jacobs chuck
- 1/4" (NPTF) air inlet thread
- 3/8" min. hose size

Model No. TG072



REVERSIBLES ANGLE DRILLS/ NON-REVERSIBLE IN-LINE DRILLS 1/8" TO 3/8" CAPACITY

For drilling in hard-to-reach areas

- Compact for confined spaces
- Rear exhaust
- Teasing throttle
- 1/4" (NPTF) air inlet thread
- 3/8" min. hose size

Model No. THZ740

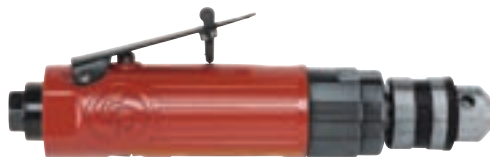

Chicago Pneumatic™

| Model No. | Mfg. No. | Chuck Size | | Spindle Thread | Free Speed RPM | Air Consumption CFM | Overall Length | | Net Weight | | Price /Each |
|-----------|----------|------------|----|----------------|----------------|---------------------|----------------|-----|------------|-----|-------------|
| | | in | mm | | | | in | mm | lbs. | kg | |
| TG070 | CP9285 | 3/8 | 10 | 3/8"-24 | 2900 | 21 | 6.5 | 165 | 2.4 | 1.1 | 159.00 |
| TG072 | CP9789 | 1/2 | 13 | 3/8"-24 | 800 | 24 | 7 | 177 | 4 | 1.8 | 269.00 |
| THZ740 | CP887 | 3/8 | 10 | 3/8"-24 | 2800 | 26 | 8.5 | 215 | 2 | 0.9 | 159.00 |

Noise levels are at 1.0 m per Pneuop Standard 8N-1. Vibration levels are per ISO 8662-1. Standard equipment: Removable support handle on TG072.

INDUSTRIAL SCREWDRIVERS

REVERSIBLE, PISTOL GRIP SCREWDRIVERS

- One hand operation reverse valve
- Compact pistol grip
- Roller clutch
- Shut-off clutch

Model No. TG090
Model No. TG091



REVERSIBLE IN-LINE SCREWDRIVERS

- Progressive lever start
- Ideal for centering screws during the fastening cycle
- Roller clutch
- Reversible
- Use for disassembly

Model No. TG092



REVERSIBLE IN-LINE SCREWDRIVERS

- Push-to-start operation
- Quick change reverse operation
- Shut-off clutch
- Ideal for continuous operation
- Positive shut-off at preset torque

Model No. TG093



Chicago Pneumatic™

| Model No. | Mfg No. | Free Speed RPM | Torque Range in.-lbs. (Nm) Soft-pull-up Work | | CFM | dBA | Vibration m/s ² | Overall Length in. (mm) | Net Weight lbs. (kg) | Price /Each |
|-----------|---------|----------------|---|----------|-----|-----|----------------------------|-------------------------|----------------------|-------------|
| | | | Min. | Max. | | | | | | |
| TG090 | CP2612 | 1470 | 3.5 (0.4) | 39 (4.4) | 14 | 75 | 2.3-3.9 | 72 (182) | 1.8 (0.8) | 554.00 |
| TG091 | CP2611 | 1000 | 3.5 (0.4) | 38 (4.3) | 20 | 76 | <2.5 | 72 (182) | 1.8 (0.8) | 1190.00 |
| TG092 | CP2621 | 1000 | 3.5 (0.4) | 39 (4.4) | 14 | 77 | 9-35 | 9.6 (224) | 2.58 (1.2) | 865.00 |
| TG093 | CP2622 | 1700 | 3.5 (0.4) | 38 (4.3) | 14 | 81 | <2.5 | 8.8 (223) | 1.39 (.7) | 799.00 |

1/4" (NPTF) air inlet thread; 3/8" min. hose size.

Noise levels are at 1.0 m per Pneuop Standard 8N-1. Vibration levels are per ISO 8662-1.



RATCHETS

1/4" RATCHETS

For light duty repair or assembly work

- Also for confined space or hard to reach areas
- 1/4" square drive spindle with pin retainer
- Reverse button
- Ball-type socket retainer
- Teasing throttle
- 1/4" (NPTF) air inlet

Model No. THZ865



3/8" RATCHETS

For assembly, including electronics, appliances, and light manufacturing

- Fast change, 3/8" square drive spindle
- Improved ratchet head
- Reverse button
- Use as hand ratchet for final torque up or to break fastener loose
- 1/4" (NPTF) air inlet

Model No. THZ869



1/2" RATCHETS

For assembly, including electronics, appliances, and light manufacturing

- Fast change, 1/2" square drive spindle
- Improved ratchet head
- Reverse button
- Use as hand ratchet for final torque up or to break fastener loose
- 1/4" (NPTF) air inlet

Model No. TG069



| Model No. | Mfg No. | Square Drive in. | Free Speed RPM | Torque Range Ft.-lbs. (Nm) | | CFM | dBA | Vibration m/s ² | Head Dimensions | | Overall Length in. (mm) | Net Weight lbs. (kg) | Price /Each |
|-----------|---------|------------------|----------------|----------------------------|---------|-----|-----|----------------------------|--------------------------------|-------------------------|-------------------------|----------------------|-------------|
| | | | | Min. | Max | | | | Ht. To Rear of Socket in. (mm) | Side to Centre in. (mm) | | | |
| THZ865 | CP825 | 1/4 | 200 | 5 (7) | 15 (20) | 10 | 87 | 10 | 1 5/16 (24) | 1 19/32 (15) | 6 1/2 (165) | 1 7/8 (.85) | 199.00 |
| THZ869 | CP828 | 3/8 | 150 | 10 (14) | 50 (68) | 16 | 92 | 10 | 1 3/16 (30.2) | 25/32 (19.8) | 10 (254) | 2 5/8 (1.2) | 178.00 |
| TG069 | CP828H | 1/2 | 150 | 10 (14) | 50 (68) | 16 | 92 | 10 | 1 3/16 (30.2) | 25/32 (19.8) | 10 (254) | 2 5/8 (1.2) | 179.00 |

Noise levels are at 1.0 m per Pneurop Standard 8N-1. Vibration levels are per ISO 8662-1. For initial loosening and final tightening, apply torque by hand, not to exceed 30 ft.-lbs. (41 Nm)

MINI RATCHET WRENCHES 1/4" & 3/8"

- Under 6" in length
- Small, lightweight and compact
- Soft handle grip
- TLZ709 has a quick release button
- Up to 27 ft.-lbs. in torque
- Speed: 275 RPM



TLZ708



| Model No. | TLZ708 | TLZ709 |
|------------------|----------------------|----------------------|
| Mfg. No. | CP9426 | CP9427 |
| Square drive: | 1/4" | 3/8" |
| Free Speed: | 275 RPM | 275 RPM |
| Torque range: | 5-27 ft.-lbs. | 5-27 ft.-lbs. |
| Length: | 5.1" | 5.1" |
| Air Flow: | 12.5 CFM | 12.5 CFM |
| Air Inlet: | 1/4" | 1/4" |
| Air Hose Bore: | - | - |
| Sound Level: | 82 dB (A) | 82 dB (A) |
| Sound Power: | 93 dB (A) | 93 dB (A) |
| Vibration Level: | 5.5 m/s ² | 4.5 m/s ² |
| Weight: | 1.08 lbs. | 1.11 lbs. |
| Price/Each | \$189.00 | \$186.00 |

LIGHTWEIGHT, HEAVY-DUTY, ALUMINUM IMPACT WRENCHES

- Lightweight, high power, low noise
- Composite body and aluminum clutch housing
- Great durability and power
- 3 forward power settings



TLZ323



| Model No. | TLZ320 | TLZ321 | TLZ322 | TLZ323 |
|------------------|----------------------|----------------------|----------------------|---------------------------|
| Mfg. No. | CP8222-R | CP8242-R | CP8252-R | CP8272-D |
| Square drive: | 3/8" | 1/2" | 1/2" | 3/4" |
| Socket retainer: | Friction ring | Friction ring | Friction ring | Both friction ring & hole |
| Clutch Type: | Twin hammer | Twin hammer | Twin hammer | Twin hammer |
| Torque working: | 184-295 ft.-lbs. | 184-295 ft.-lbs. | 220-590 ft.-lbs. | 100-960 ft.-lbs. |
| Torque max.: | 331 ft.-lbs. | 479 ft.-lbs. | 775 ft.-lbs. | 1217 ft.-lbs. |
| Length: | 6.96" | 6.96" | 7.87" | 9.05" |
| Air Flow: | 32 CFM | 32 CFM | 28.8 CFM | 48 CFM |
| Air Inlet: | 1/4" NPTF | 1/4" NPTF | 1/4" NPTF | 3/8" NPTF |
| Air Hose Bore: | 3/8" | 3/8" | 3/8" | 1/2" |
| Sound Level: | 89 dBA | 89 dBA | 94 dBA | 96 dBA |
| Sound Power: | 100 dBA | 100 dBA | 105 dBA | 107 dBA |
| Vibration Level: | 3.9 m/s ² | 3.9 m/s ² | 7.9 m/s ² | 9 m/s ² |
| Weight: | 2.53 lbs. | 2.64 lbs. | 4.4 lbs. | 7.16 lbs. |
| Price/Each | \$329.00 | \$329.00 | \$345.00 | \$729.00 |

DIRECT DRIVE REVERSIBLE SCREWDRIVERS

- Suitable for variable torque
- High speed fast screw rundown
- Ergonomic pistol grip improves operator comfort and productivity

| | |
|------------------------|-------------------------|
| Model No. | TLZ339 |
| Mfg. No. | CP2755 |
| Clutch Type | Direct drive reversible |
| Handle style | Pistol grip |
| Operation | Trigger start |
| Free Speed | 2200 RPM |
| Output | Hex. 1/4" |
| Torque range | 124 in.-lbs. |
| Length | 6.3" |
| Weight | 2.27 lbs. |
| Air Flow | 29 CFM |
| Air Inlet | 1/4"NPTF |
| Air Hose Bore | 3/8" |
| Sound Level | 90 dBA |
| Vibration Level | <2.5 m/s ² |
| Price/Each | \$279.00 |



POSITIVE CLUTCH REVERSIBLE SCREWDRIVERS

- Quick change chuck
- Operator can force clutch engagement for higher torque
- Reverse control at the trigger
- Good for prevailing torque applications
- High speed and high torque

| | |
|------------------------|-----------------------|
| Model No. | TLZ340 |
| Mfg. No. | CP2780 |
| Clutch Type | Positive clutch |
| Handle style | Pistol grip |
| Operation | Trigger start |
| Free Speed | 2100 RPM |
| Output | Hex. 1/4" |
| Torque range | 133 in.-lbs. |
| Length | 6.46" |
| Weight | 2.35 lbs. |
| Air Flow | 29 CFM |
| Air Inlet | 1/4"NPTF |
| Air Hose Bore | 3/8" |
| Sound Level | 89 dBA |
| Vibration Level | 26.8 m/s ² |
| Price/Each | \$349.00 |



SANDERS

RANDOM ORBITAL SANDERS

Use the orbital motion for fine finishing; rotary motion for rapid material removal.

- Balanced counterweight design
- Heavy-duty bearing construction
- Cross-bolt-style hub mounting
- 1/4" (NPTF) air inlet thread
- 3/8" min. hose size

Model No. THZ829



THZ829

MINI ROTARY SANDERS

- Ideal for small work area
- Adjustable speed regulator
- Through-handle exhaust
- Directs exhaust air away from the operator/workpiece
- Match the speed to the job

Model No. TG086



TG086

SANDERS

For use in a variety of sanding, blending and smoothing operations in the appliance, construction, shipyard and electronics industries or wherever metal or fiberglass is being prepared or finished.

Model No. TG084

Model No. TG085



TG084



TG085



| Model No. | Mfg. No. | Paper Size | | Spindle Thread | Free Speed RPM | CFM | dBA | Vibration m/s ² | Net Weight | | Price /Each |
|-----------|----------|------------|-----|----------------|----------------|-----|-----|----------------------------|------------|-----|-------------|
| | | in. | mm | | | | | | lbs. | kg | |
| THZ829 | CP870 | 6 | 150 | 5/16"-24 | 10000 | 18 | 94 | <2.5 | 4 | 1.9 | 96.20 |
| TG084 | CP72655 | 7 | 178 | 5/8"-11 | 4500 | 24 | 89 | <2.5 | 4.5 | 2.0 | 433.00 |
| TG085 | CP72695 | 7 | 178 | 5/8"-11 | 4500 | 24 | 89 | <2.5 | 6.5 | 3.0 | 399.00 |
| TG086 | CP7202 | 3 | 75 | 3/8"-24 | 14000 | 19 | 77 | <2.5 | 1.5 | 0.7 | 159.00 |

Noise levels are at 1.0 m per Pneuop Standard 8N-1. Vibration levels are per ISO 8662-1.

ANGLE GRINDERS

For cleaning, deburring, blending and smoothing

- 0.8 HP motor
- Aluminum alloy housing
- Spiral bevel gearing in angle head
- 1/4" (NPTF) air inlet
- 3/8" minimum hose size

Model No. TG080

Model No. TG081

Model No. TLV383



7" ANGLE GRINDERS

For cleaning, deburring, blending, and smoothing

- Use with 7", Type 27 grinding wheels
- 1.12 HP motor
- Aluminum alloy housing
- Spiral bevel gearing in angle head
- 3/8" (NPTF) air inlet
- 3/8" minimum hose size

Model No. TKZ804



| Model No. | Mfg No. | Wheel Size in. (mm) | Spindle Thread" | Free Speed RPM | CFM | dBA | Vibration m/s ² | Overall Length Less Guard in. (mm) | Net Weight Less Guard lbs. (kg) | Price /Each |
|-----------|----------|---------------------|-----------------|----------------|-----|-----|----------------------------|------------------------------------|---------------------------------|-------------|
| TG080 | CP9120CR | 4 (102) | 3/8-24 | 14000 | 21 | 84 | 7.5 | 9 (229) | 4.0 (1.8) | 329.00 |
| TG081 | CP9121CR | 5 (127) | 3/8-24 | 12000 | 21 | 84 | 8.1 | 9 (229) | 4.2 (1.9) | 327.00 |
| TLV383 | CP9122BR | 4.5 (114) | 5/8-11 | 12000 | 30 | 84 | 8.6 | 9 | 4.2 | 339.00 |
| TKZ804 | CP9123 | 7 (178) | 5/8-11 | 7500 | 33 | 93 | 4.2 | 13 1/8 (333) | 6 1/4 (2.84) | 599.00 |

Noise levels are at 1.0 m per Pneuop Standard 8N-1. Vibration levels are per ISO 8662-1.



AIR SCRIBE® PENS

- Vibration level: 4.2 m/s²
- INCLUDED ACCESSORIES:**
 - Air hose - 3/16" (5 mm) I.D.
 - Air filter assembly
 - Stylus - carbide tipped for writing and engraving
 - Anvil for use with chisels and blank
 - Flat chisel for scaling and deburring
 - Chisel blank, customized to suit
 - Round nose chisel for cleaning weld beads
 - Carrying case



| Model No. | Mfg. No. | Max Blows Per Minute | | Weight lbs. kg | | Length in. mm | | Air Flow L/s CFM | | Min Hose Bore in. mm | | Sound Level dBA | Price /Each |
|------------------------|--------------|----------------------|-----|----------------|------|---------------|--------------------|------------------|-----|----------------------|---|-----------------|-------------|
| | | | | | | | | | | | | | |
| AIR SCRIBE® KIT | | | | | | | | | | | | | |
| TCW246 | CP9361-1 KIT | 13 | 500 | 0.31 | 0.14 | 5 | 127 | 0.5 | 1.1 | 3/16 | 5 | 79 | 629.00 |
| TKZ813 | POS4177 | | | | | | Replacement Stylus | | | | | | 33.90 |

NON-VACUUM ORBITAL SANDERS

- Random orbital sanders for general sanding, orbit dia. 3/16" (5 mm)**
- Low noise and vibration
 - 3/16" orbit



COMPACT ENGRAVING PENS

- Finger tip start valve
- Fine point stylus
- Enhanced control
- Compact and lightweight
- Engraves at 32 400 BPM
- Quiet operation @ 59 dB(A)



Model No. THZ727
Mfg. No. CP9160
Price/Each \$199.00



| Model No. | Mfg. No. | Pad Size in. mm | | Weight lbs. kg | | Height with Pad in. mm | | Air Consumption (CFM) Average At load | | Air Inlet Thread" | Hose I.D." | Price /Each |
|-----------|----------|-----------------|-----|----------------|------|------------------------|----|---------------------------------------|------|-------------------|------------|-------------|
| | | | | | | | | | | | | |
| TCW303 | CP3511 | 5 | 127 | 1.63 | 0.74 | 3 1/4 | 83 | 8.0 | 16.6 | 1/4 | 1/4 | 269.00 |
| TDU633 | CP7255 | 6 | 150 | 1.74 | 0.79 | 3 1/4 | 83 | 8.0 | 16.6 | 1/4 | 1/4 | 246.00 |

INDUSTRIAL DIE GRINDERS

- Excellent ergonomics
- Very low maintenance
- Low vibration
- Built for continuous use



| Model No. | Mfg. No. | Free Speed RPM | Collet Max Capacity" | HP | Power W | Weight | | At Free Speed CFM | Air Consumption | | Air Inlet Thread" | Hose I.D." | Price /Each |
|-----------|--------------|----------------|----------------------|-----|---------|--------|------|-------------------|-----------------|-------------------|-------------------|------------|-------------|
| | | | | | | lbs. | kg | | L/s | At Max Output CFM | | | |
| TCW168 | CP3451-18SEC | 18000 | 1/4 | 1.0 | 750 | 3.1 | 1.4 | 14 | 6.7 | 17 | 8 | 5/16 | 649.00 |
| TCW258 | CP3000-424R | 24000 | 1/4 | 0.5 | 400 | 1.8 | 0.84 | 27 | 13 | 25 | 12 | 1/4 | 417.00 |
| TCW144 | CP3030-420R | 13000 | 1/4 | 0.8 | 600 | 2.6 | 1.3 | 21 | 10 | 40 | 19 | 3/8 | 519.00 |
| TCW044 | CP3109-13AC | 13000 | 1/4 | 0.8 | 600 | 2.4 | 1.1 | 21 | 10 | 32 | 15 | 3/8 | 1199.00 |
| TCW088 | CP3109-24ES | 24000 | 1/4 | 0.8 | 600 | 2.9 | 1.3 | 21 | 10 | 32 | 15 | 3/8 | 1176.00 |
| TCW174 | CP3109-24 | 24000 | 1/4 | 0.8 | 600 | 2.0 | 0.9 | 21 | 10 | 32 | 15 | 3/8 | 879.00 |

BELT SANDERS

- Ergonomic design
- Low maintenance motor
- Easy belt changes
- Unequaled power to weight ratio



TCW005



TCW006

| Model No. | Mfg. No. | Free Speed RPM | Belt Size L x l | | Power | | Weight | | Air Consumption At Free Speed | | Air Inlet Thread" | Hose I.D." | Price /Each |
|-----------|----------|----------------|-----------------|----------|-------|-----|--------|------|-------------------------------|-----|-------------------|------------|-------------|
| | | | in. | mm | HP | W | lbs. | kg | CFM | L/s | | | |
| TCW005 | CP9779 | 22000 | 13 x 3/8 | 330 x 10 | 0.4 | 300 | 2.09 | 0.95 | 14 | 6 | 1/4 | 3/8 | 279.00 |
| TCW006 | CP9780 | 20000 | 20.4 x 3/4 | 520 x 20 | 0.4 | 300 | 2.09 | 0.95 | 15 | 7 | 1/4 | 3/8 | 349.00 |

UTILITY HAMMERS

For light to medium duty chipping, trimming, riveting, cutting, piercing & peening jobs

- Aluminum body
- 2 5/8" stroke (TG087), 3 1/2" stroke (TG088)
- Piston air-cushioned on return stroke
- 1/4" (NPTF) air inlet
- 3/8" minimum air hose size



TG087



TG088



| Model No. | Mfg. No. | Capacity Cold Rivets in. (mm) | | Bore and Stroke in. (mm) | Blows per Minute | Rivet Set and Chisel Shank | CFM | dBA | Vibration m/s ² | Overall Length in. (mm) | Net Weight lbs. (kg) | Price /Each |
|-----------|----------|-------------------------------|------------|--------------------------|------------------|----------------------------|-----|-----|----------------------------|-------------------------|----------------------|-------------|
| | | Dural | Steel | | | | | | | | | |
| TG087 | CP7111 | 1/4 (6.4) | 3/16 (4.8) | 3/4 x 2 5/8 (19 x 67) | 3000 | 0.401 (10.19 mm) | 25 | 100 | 8.9 | 6 3/4 (171) | 3 1/2 (1.6) | 83.50 |
| TG088 | CP7150 | 5/16 (7.9) | 1/4 (6.4) | 3/4 x 3 1/2 (19 x 89) | 2300 | 0.401 (10.19 mm) | 25 | 100 | 9.4 | 8 7/8 (225) | 4.2 (1.9) | 99.50 |

Noise levels are at 1.0 m per Neurop Standard 8N-1. Vibration levels are per ISO 8662-1.

INDUSTRIAL CHIPPERS/SCALERS

- For industrial use
- Powerful
- Durable



TCW253



TCW235



TCW108



| Model No. | Mfg. No. | Bore | | Stroke | | Shank" | Blows Per Minute | Weight | | Air Consumption At Free Speed | | Air Inlet Thread" | Hose I.D." | Price /Each |
|-----------|----------|------|------|--------|------|----------------|------------------|--------|-----|-------------------------------|-----|-------------------|------------|-------------|
| | | in. | mm | in. | mm | | | lbs. | kg | CFM | L/s | | | |
| TCW253 | CP9356NS | 0.71 | 18.0 | 1.18 | 30.0 | ISO 1/2 square | 3800 | 3.3 | 1.5 | 3.0 | 1.4 | 1/4 | 5/16 | 589.00 |
| TCW235 | CP9356WF | 0.93 | 23.5 | 1.40 | 35.6 | ISO 1/2 square | 3000 | 4.4 | 2.0 | 5.5 | 2.6 | 1/4 | 3/8 | 663.00 |
| TCW108 | CP0952 | 1.30 | 33.0 | 1.94 | 49.2 | ISO 1/2 square | 2200 | 8.8 | 4.0 | 8.5 | 4.0 | 1/4 | 3/8 | 859.00 |

AIR TOOLS

WELD FLUX CHIPPERS & NEEDLE SCALERS

- For removing rust, scale, paint & medium duty weld flux removal
- Simple plate valve design allows for smooth throttling
- Heat-treated piston, cylinder sleeve and chisel bushing for long life
- Removal of needle attachment converts tool to a weld flux chipper

| | |
|-------------------------|----------------------|
| Model No. | TLZ158 |
| Mfg. No. | CP7120 |
| Bore | 1 1/8" |
| Blows per minute | 4800 BPM |
| Shank | 1/2 sq.in. |
| Length | 18" |
| Weight | 6.2 lb |
| Air Flow | 15.5 CFM |
| Min. Hose Size | 3/8" |
| Air Inlet | 1/4" NPT |
| Sound Level | 99 dBA |
| Sound Power | 110 dBA |
| Vibration Level | 9.7 m/s ² |
| Price/Each | \$275.00 |

Kit Includes:
 1 x Tool Body
 1 x 19 needles
 1 x 35 mm chisel



HEAVY-DUTY AIR SHEARS

- Cuts up to 18 gauge steel
- Powerful 1/2 HP motor
- Triple idler planetary gears
- Ergonomic handle design
- 1/4" (NPTF) air inlet

Model No. TG096

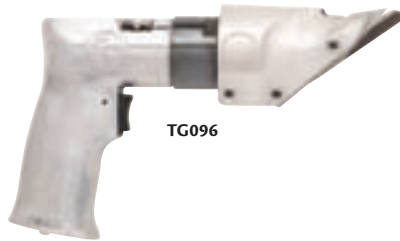

TG096

HEAVY-DUTY RECIPROCATING AIR SAW

- Ergonomic rubber grip
- Heavy-duty construction
- Lock-off throttle
- Universal saw blade holder
- 1/4" (NPTF) swivel air inlet
- 3/8" minimum hose size
- Includes: Replacement blades, 18T, 24T, 32T and carry case

Model No. THZ855



THZ855



| Model No. | Mfg. No. | Strokes per Minute | Capacity Steel | CFM | dBA | Vibration m/s ² | Overall Length in. (mm) | Net Weight lbs. (kg) | Price /Each |
|-----------|----------|--------------------|----------------|-----|-----|----------------------------|-------------------------|----------------------|-------------|
| TG096 | CP7855 | 2400 | 18 gauge | 50 | 92 | 3.2 | 8 2/3 (220) | 2 1/2 (1.1) | 359.00 |
| THZ855 | CP7901K | 10000 | 16 gauge | 27 | 88 | <2.5 | 10 1/2 (268) | 1.9 (.86) | 337.00 |

Noise levels are at 1.0 m per Pneuop Standard 8N-1. Vibration levels are per ISO 8662-1.
 *Standard equipment: saw blade, 24 teeth per in.

INDUSTRIAL IMPACT WRENCHES

- Heavy-duty
- More durable
- More serviceable

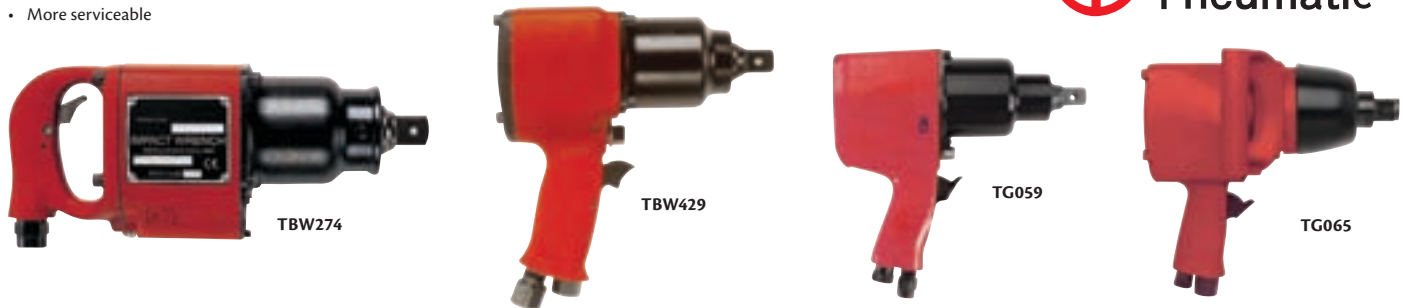

TBW274

TBW429

TG059

TG065

| Model No. | Mfg. No. | Drive" | Socket Retainer | Clutch Type | Handle Style | Torque Working pi-lbs. | Torque max ft-lbs. | Air Consumption CFM* | Overall Length" | Side to Center" | Weight lbs. | Price /Each |
|--|--------------|--------|-----------------|-------------|------------------|------------------------|--------------------|----------------------|-----------------|-----------------|-------------|-------------|
| 3/4" DRIVE- 75-650 FT-LB | | | | | | | | | | | | |
| TBW429 | CP6060 SASAB | 3/4 | Hole | 2-jaw | Pistol | 650 | 1000 | 42 | 7.63 | 1.78 | 11.6 | 2881.00 |
| TG059 | CP9561 | 3/4 | Hole | Pin | Pistol | 500 | 750 | 30 | 8.5 | 1.535 | 11.1 | 1109.00 |
| 1"-1 1/2" DRIVE- 280-2400 FT-LB | | | | | | | | | | | | |
| TBW274 | CP0611 PASED | 1 | Hole | 2-jaw | D inside trigger | 900-1800 | 2800 | 85 | 12.5 | 2.25 | 22.4 | 5445.00 |
| TG065 | CP0611P RS | 1 | Hole | 2-jaw | Pistol | 900 | 2800 | 48 | 10.7 | 1.811 | 23.1 | 4549.00 |

*Free speed

Torque ranges should be used as a guide only. Final torque will depend on the joint, operating pressure and drive accessories. Air inlet 1/4" NPT.

INDUSTRIAL ANGLE GRINDERS

- Powerful production tool
- Easy maintenance
- Lubricate only every 1000 hours
- Unequaled power to weight ratio



TCW014



TBW661



| Model No. | Mfg. No. | Free Speed RPM | Wheel | | Threaded Spindle | Power | | Weight | | Air Consumption | | | | Air Inlet Thread" | Hose I.D." | Price /Each |
|-----------|--------------|----------------|-------------------|-----|------------------|-------|-----|--------|-----|-------------------|-----|-------------------|-----|-------------------|------------|-------------|
| | | | Max. Capacity in. | mm | | HP | W | lbs. | kg | At Free Speed CFM | L/s | At Max Output CFM | L/s | | | |
| TCW014 | CP3450-12AC4 | 12000 | 4 | 100 | 3/8"-24 | 1.1 | 810 | 3.7 | 1.7 | 18 | 10 | 36 | 18 | 3/8 | 1/2 | 836.00 |
| TBW661 | CP3450-12AB5 | 12000 | 5 | 127 | 5/8"-11 | 1.1 | 810 | 6.3 | 2.9 | 18 | 14 | 36 | 18 | 1/2 | 1/2 | 836.00 |

GRINDERS

MINI ANGLE DIE GRINDERS

For high-speed blending, smoothing, porting and deburring in confined areas.

- Compact, lightweight design
- Lock-off throttle
- 90° angle head
- Front exhaust
- 1/4" (NPTF) air inlet thread
- 3/8" min. hose size

Model No. TG077



TG077

DIE GRINDERS & EXTENDED SPINDLE DIE GRINDERS

For die contouring and repair, weld cleaning, casting and forging cleanup, deburring, blending, and smoothing.

- 1/2 HP motor
- Square handle design
- Lock-off throttle
- Rear exhaust
- TG079 - 6" extended spindle
- 1/4" (NPTF) air inlet thread
- 3/8" min. hose size

Model No. TG078, TG079



TG078

MINI DIE GRINDERS

For high-speed blending, smoothing, porting and deburring in confined areas.

- Compact, lightweight design
- Lock-off throttle
- Front exhaust
- 1/4" (NPTF) air inlet thread
- 3/8" min. hose size

Model No. TG076



TG076



| Model No. | Mfg. No. | Collet Size | | Spindle Thread" | Free Speed RPM | CFM | dBA | Vibration m/s ² | Overall Length | | Net Weight | | Price /Each |
|-----------|----------|-------------|----|-----------------|----------------|-----|-----|----------------------------|----------------|-----|------------|------|-------------|
| | | in. | mm | | | | | | in. | mm | lbs. | kg | |
| TG076 | CP876 | 1/4 | 6 | 3/8"-24 | 28000 | 16 | 101 | 2.5 | 43/4 | 119 | 3/4 | 0.3 | 97.90 |
| TG077 | CP875 | 1/4 | 6 | 3/8"-24 | 21000 | 16 | 101 | 2.5 | 47/8 | 123 | 1 | 0.5 | 93.50 |
| TG078 | CP860 | 1/4 | 6 | M10 x 1.25" | 24000 | 20 | 90 | 3.0 | 53/4 | 146 | 1 1/4 | 0.6 | 189.00 |
| TG079 | CP860ES | 1/4 | 6 | M10 x 1.25" | 24000 | 20 | 90 | 3.0 | 11 3/4 | 298 | 2 1/10 | 0.95 | 399.00 |

Noise levels are at 1.0 m per Pneurop Standard 8N-1. Vibration levels are per ISO 8662-1.

8 PIECE SOLID CARBIDE BURR SETS - 1/4" SHANK

Model No. BL445
Mfg. No. SC90801
Price/Each \$390.00



CLARKSON OSBORN

KIT CONTAINS:

| No. | Head Dia." | Flute Length" |
|------|------------|---------------|
| SA-5 | 1/2 | 1 |
| SC-3 | 3/8 | 3/4 |
| SC-5 | 1/2 | 1 |
| SD-5 | 1/2 | 7/16 |
| SE-3 | 3/8 | 3/4 |
| SF-5 | 1/2 | 1 |
| SG-3 | 3/8 | 3/4 |
| SL-4 | 1/2 | 1 1/8 |

FOR CARBIDE BURRS, PLEASE SEE PAGES 990-991





DYNAFILE® ABRASIVE BELT MACHINES

- Replaces tedious hand filing and sanding
- Superior belt tracking and fast abrasive belt changes
- New composite quick-change housing cover reduces vibration and is thermal-insulated
- New belt housing has larger opening for belt tracking and operation
- Includes: Contact arm THZ336

DYNAFILE® VERSATILITY KITS

TGY725 Dynaflex® with 5 contact arms, **THZ353**, **THZ354**, **THZ336**, **THZ337** & **THZ355** and abrasive belts in a durable case

Model No. TGY726
Mfg. No. 14010
Price/Each \$999.00

Model No.
Mfg. No.
Abrasive Belt Size:

Air Flow Rate @ 90 PSI:
Sound Level:
Horsepower:
Free Speed:
Air Pressure:
Air Inlet Thread:
Hose Size (I.D.):
Max. SFPM:
Length:
Height:
Weight:
Price/Each:

TGY725
 14000
 1/8-1/2" W x 24" L
 (3-13 mm x 610 mm)
 31 SCFM
 77 dB (A)
 0.50 HP
 20000 RPM
 90 PSI
 1/4 NPT
 3/8" (10 mm)
 5800 SFPM
 14 3/5" (371 mm)
 4" (102 mm)
 3.1 lbs. (1.41 kg)
\$811.00



TGY726 Versatility Kit



DYNAFILE® II ABRASIVE BELT MACHINES

- New lightweight composite housing reduces vibration and is thermal-insulated to prevent cold air transmission to the operator's hand. Grinding head pivots 360°
- Air motor easily converts to 1/4" die grinder or 1/4" drill
- Order collet and chuck separately

DYNAFILE® II VERSATILITY KITS

Kit Includes: Dynaflex® II model **TGY737**, 3-contact arms (**THZ343**, **THZ341** & **THZ342**), 8-abrasive belts, 1/4" Collet for die grinder use and carrying case

Model No. TGY738
Mfg. No. 40321
Price/Each \$966.00

Model No.
Mfg. No.
Abrasive Belt Size:

Air Flow Rate @ 90 PSI:
Sound Level:
Horsepower:
Free Speed:
Air Pressure:
Air Inlet Thread:
Hose Size (I.D.):
Max. SFPM:
Length:
Height:
Weight:
Price/Each:

TGY737
 40320
 1/4" - 3/4" W x 18"- 24" L
 (6-19 mm x 457-610 mm)
 28 SCFM
 80 dB (A)
 0.50 HP
 20000 RPM
 90 PSI
 1/4 NPT
 3/8" (10 mm)
 4550 SFPM
 14 1/4" (362 mm)
 4 7/8" (124 mm)
 2.5 lbs. (1.14 kg)
\$797.00



TGY738 Versatility Kit



ELECTRIC DYNAFILE® II ABRASIVE BELT MACHINES

- Runs coated-abrasive and non-woven nylon belts
- Ideal for grinding, deburring, blending, finishing and surface conditioning
- Tool includes model **THZ341** contact arm, for abrasive belts 1/2" wide by 18" long
- Tool accepts over 20 interchangeable contact arms
- Sanding head pivots 360°, for working in previously inaccessible areas
- Side handle included for operator comfort
- Handle is reversible for left or right hand use
- Tool is double-insulated for safety, includes electric cord 8 feet in length

ELECTRIC DYNAFILE® II VERSATILITY KITS

- Includes model **TGY744** electric Dynaflex® II with model **THZ341** contact arm, and two additional arms models **THZ340** and **THZ342**, eight abrasive belts of various grits, and an assortment of platen pads
- All items contained in handy and durable carrying case

Model No. TGY745 **Mfg. No. 40611** **Price/Each \$628.00**

Model No.
Mfg. No.
Abrasive Belt size:

Max. RPM:
Max. SFPM:
Length:
Height:
Weight:
Price/Each:

TGY744
 40610
 1/4" - 3/4" W x 18"- 24" L
 (6-19 mm x 457-610 mm)
 11 000 RPM
 2520 SFPM
 19" (445 mm)
 5 1/2" (121 mm)
 5 lbs. (2.1 kg)
\$458.00



TGY745 Versatility Kit



MINI-DYNAFILE® II ABRASIVE BELT MACHINES

- Pop-off guard for easy abrasive belt changes
- Multi-positioning grinding head pivots 360°
- Easy abrasive belt tracking with adjustment knob
- Strap polish, grind, deburr, enter narrow openings
- Materials: woodworking, metal, ceramics, composites, stainless steel, plastics, fiberglass, rubber, glass & stone

MINI-DYNAFILE® II VERSATILITY KITS

- Kit includes: Mini-Dynaflex® model **TGY731**, 2 additional contact arms (models **THZ346** and **THZ356**), assorted belts, threaded collet insert and durable carrying case
- Multi-positioning grinding head pivots 180°
- Easy abrasive belt tracking with adjustment knob

Model No. TGY732
Mfg. No. 15006
Price/Each \$917.00

Model No.
Mfg. No.
Abrasive Belt Size:

Air Flow Rate @ 90 PSI:
Sound Level:
Horsepower:
Free Speed:
Air Pressure:
Air Inlet Thread:
Hose Size (I.D.):
Max. SFPM:
Length:
Height:
Weight:
Price/Each:

TGY731
 15003
 1/8-1/2" W x 12" L
 (3-13 mm x 305 mm)
 20 SCFM
 78 dB (A)
 0.35 HP
 25 000 RPM
 90 PSI
 1/4 NPT
 1/4" (6 mm)
 4890 SFPM
 10 3/4" (273 mm)
 3 1/2" (89 mm)
 1.8 lbs. (0.82 kg)
\$788.00

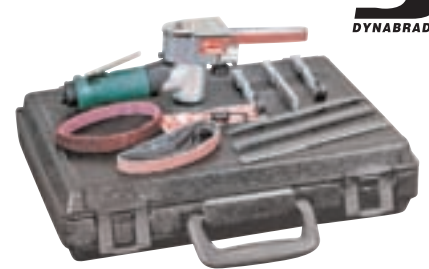

TGY732 Versatility Kit





DYNAFILE® III ABRASIVE BELT MACHINES

- Lightweight, ergonomic design for operator control & comfort
- Composite housing reduces vibration and is thermal-insulated to prevent cold air transmission to operator
- Grinding head pivots 360°

DYNAFILE® III VERSATILITY KITS

- Composite housing reduces vibration and is thermal-insulated to prevent cold air transmission to operator.
- Grinding head pivots 360°
- Kit includes: Dynafile® III model TGY733, 3-Contact Arms models THZ348, THZ357 and THZ351, spare drive wheel, wrenches, hex keys, 6 abrasive belts and carrying case

Model No. TGY734 Mfg. No. 15302
Price/Each \$1257.00

Model No. TGY733
Mfg. No. 15300
Abrasive Belt Size: 1/4" - 1" W x 18" L (6-25 mm x 457 mm)
Air Flow Rate @ 90 PSI: 32 SCFM
Sound Level: 87 dB (A)
Horsepower: 0.70 HP
Free Speed: 20000 RPM
Air Pressure: 90 PSI
Air Inlet Thread: 1/4 NPT
Hose Size (I.D.): 3/8" (10 mm)
Max. SFPM: 4550 SFPM
Length: 14 1/4" (362 mm)
Height: 4 7/8" (124 mm)
Weight: 2.5 lbs. (1.14 kg)
Price/Each: \$1059.00



TGY734 Versatility Kit

DYNAFILE® CONTACT ARMS

4" to 14" Workable Reach (Includes bearing and shaft)



| Model No. | Mfg. No. | Description | Belt Size | Contact Wheel Ass. | Platen Pad | Price /Each |
|-----------|----------|---|-------------------------|--|-----------------|-------------|
| THZ336 | 11218 | Standard Arm on TGY725 | 1/2" x 24" | 11078 5/8" Dia. x 3/8" W, rubber | 11025 1/2" W | 78.70 |
| THZ337 | 11219 | No platen due to off set design, Grind radiuses, slack polish, Offset for slack polishing | 1/4", 5/16" or 2" x 24" | 11080 1" Dia. x 3/8" wide, radius rubber | None | 78.70 |
| THZ338 | 11232 | For 1/8" wide belts, No platen due to offset design Grind corners, strap polish | 1/8" or 1/4" x 24" | 11086 1" Dia. x 3/8" W, tapered urethane | None | 96.50 |
| THZ339 | 11215 | Enter 1/2" x 1/2" openings | 1/4" x 24" | 11072 7/16" Dia. x 1/4" wide 1/8" wide, brass | 11034 | 93.20 |

DYNAFILE® II CONTACT ARMS

For Air and electric Models - 4" to 17" Workable Reach



| Model No. | Mfg. No. | Description | Belt Size | Contact Wheel Ass. | Platen Pad | Price /Each |
|-----------|----------|--|---------------------------------|--|-----------------|-------------|
| THZ340 | 11202 | Enter 5/16" x 3/4" openings | 1/4" x 18" | 11074 5/8" Dia. x 1/8" W, rubber | 11032 1/4" W | 78.70 |
| THZ341 | 11203 | Standard on Models TGY742 and TGY744, Grind over contact wheel or platen | 1/2" x 1/8" | 11078 5/8" Dia. x 3/8" W, rubber | 11025 1/2" W | 78.70 |
| THZ342 | 11204 | Unique offset design Strap polishing is easy with this arm | 1/8", 1/4", 5/16" or 1/2" x 18" | 11080 1" Dia. x 3/8" W, radiused rubber | None | 78.70 |
| THZ343 | 11206 | Standard on models TGY737 and TGY741 | 5/8" or 3/4" x 18" | 11282 3/4" Dia. x 5/8" W, rubber | 11109 3/4" W | 91.70 |
| THZ344 | 11280 | Grind corners, enter grooves, strap polish "V" shape wheel | 1/8" or 1/4" x 18" | 11086 1" Dia. x 3/8" W, urethane, tapered | None | 99.90 |

DYNAFILE® III CONTACT ARMS

4" to 6 3/4" Workable Reach



| Model No. | Mfg. No. | Description | Belt Size | Contact Wheel Ass. | Platen Pad | Price /Each |
|-----------|----------|---|-----------|--|---------------|-------------|
| THZ348 | 15350 | Reversible Arm - arm can be flipped to allow for platen sanding or strap polishing Standard with tool | 1" x 18" | 15349 90 durometer 2" Dia. x 1" W | 15323 1" W | 217.00 |
| THZ349 | 15351 | Reversible Arm - arm can be flipped to allow for platen sanding or strap polishing | 1" x 18" | 15348 70 durometer 2" Dia. x 1" W | 15323 1" W | 217.00 |
| THZ350 | 15356 | Reversible Arm - arm can be flipped to allow for platen sanding or strap polishing | 1" x 18" | 15346 40 durometer 2" Dia. x 5/8" W | 15323 1" W | 217.00 |
| THZ351 | 15357 | Reversible Arm - arm can be flipped to allow for platen sanding or strap polishing "V" shape wheel | 1" x 18" | 15347 2" Dia. x 1" W | 15323 1" W | 217.00 |
| THZ352 | 15375 | Great for strap polishing | 1" x 24" | 15348 70 durometer 2" Dia. x 1" W | None | 293.00 |

MINI-DYNAFILE® II CONTACT ARMS

3" workable Reach



| Model No. | Mfg. No. | Description | Belt Size | Contact Wheel Ass. | Platen Pad | Price /Each |
|-----------|----------|---|----------------------------------|-------------------------------------|------------|-------------|
| THZ345 | 15026 | Standard on model TGY731 Grind corners, enter grooves, strap polish | 1/2" x 12" 5/8" Dia. x 3/8" W | 11078 1/2" W rubber | 11026 | 78.70 |
| THZ346 | 15028 | No Platen due to offset design Grind radiuses, slack polish or Offset for slack polishing | 1/4" x 5/16" 1/2" x 12" | 11080 1" Dia. x 3/8" wide rubber | None | 78.70 |
| THZ347 | 15029 | Grind corners, enter grooves and strap polish | 1/8" x 12" | 11086 1" Dia. x 3/8" W urethane | None | 99.90 |

AIR TOOLS

5" NON-VACUUM DYNORBITAL-SPIRIT® RANDOM ORBITAL SANDERS

- Palm-style grip
- Colour-coded composite lever (identifies orbit size)
- Low sound levels
- One-piece speed control dial
- Custom engineered composite cylinder
- Double row balancer bearing keeps out contaminants
- Includes low profile, premium urethane, weight-mated, non-vac pad for use with PSA discs
- Can be converted easily to self-generated or central vac model for hook-up to dust collection system



| Model No | TGY861 | TGY852 | TGY870 |
|--------------------------------|---------------------------|---------------------------|---------------------------|
| Mfg. No. | 59020 | 59005 | 59035 |
| Abrasive Information: | 5" dia. discs (127 mm) | 5" dia. discs (127 mm) | 5" dia. discs (127 mm) |
| Pad Information: | 5" dia. pad (127 mm) | 5" dia. pad (127 mm) | 5" dia. pad (127 mm) |
| Air Flow Rate @ 90 PSI: | 14 SCFM | 14 SCFM | 14 SCFM |
| Sound Level: | 80 dB (A) | 82 Db (A) | 79 dB (A) |
| Horsepower: | 0.25 HP | 0.25 HP | 0.25 HP |
| Free Speed: | 12 000 RPM | 12 000 RPM | 12 000 RPM |
| Air Pressure: | 90 PSI | 90 PSI | 90 PSI |
| Air Inlet Thread: | 1/4 NPT | 1/4 NPT | 1/4 NPT |
| Hose Size (I.D.): | 1/4" (6 mm) | 1/4" (6 mm) | 1/4" (6 mm) |
| Orbit Diameter: | 3/16" (4.8 mm) | 3/8" (9.5 mm) | 3/32" (2.4 mm) |
| Tool Spindle Thread: | 5/16"- 24 female | 5/16"- 24 female | 5/16"- 24 female |
| Length: | 6 1/2" (165 mm) | 6 1/2" (165 mm) | 6 1/2" (165 mm) |
| Height: | 3 1/2" (89 mm) | 3 1/2" (89 mm) | 3 1/2" (89 mm) |
| Weight: | 1.4 lbs. (0.64 kg) | 1.5 lbs. (0.68 kg) | 1.4 lbs. (0.64 kg) |
| Price/Each | \$248.00 | \$248.00 | \$248.00 |



TGY861

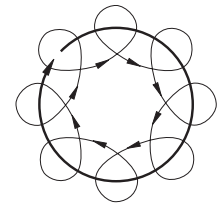

3/16" (5 mm) dia. orbit
for general sanding



TGY852

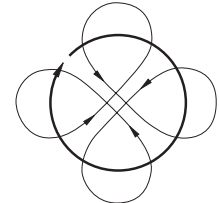

3/8" (10 mm) dia. orbit
for aggressive sanding



TGY870

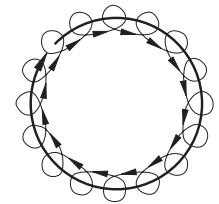

3/32" (2.5 mm) dia. orbit
for ultra-fine sanding

6" NON-VACUUM DYNORBITAL-SPIRIT™ RANDOM ORBITAL SANDERS

- Palm-style grip
- Colour-coded composite lever (identifies orbit size)
- Low sound levels
- One-piece speed control dial
- Custom engineered composite cylinder
- Double row balancer bearing keeps out contaminants
- Includes low profile, premium urethane, weight-mated, non-vac pad
- Can be converted easily to self-generated system or central vac model for hook-up to dust collection system



TGY873



TGY855

| Model No. | TGY855 | TGY873 |
|--------------------------------|---------------------------|---------------------------|
| Mfg. No. | 59010 | 59040 |
| Abrasive Information: | 6" dia. discs (152 mm) | 6" dia. discs (152 mm) |
| Pad Information: | 6" dia. pad (152 mm) | 6" dia. pad (152 mm) |
| Air Flow Rate @ 90 PSI: | 14 SCFM | 14 SCFM |
| Sound Level: | 80 dB (A) | 80 dB (A) |
| Horsepower: | 0.25 HP | 0.25 HP |
| Free Speed: | 12 000 RPM | 12 000 RPM |
| Air Pressure: | 90 PSI | 90 PSI |
| Air Inlet Thread: | 1/4 NPT | 1/4 NPT |
| Hose Size (I.D.): | 1/4" (6 mm) | 1/4" (6 mm) |
| Orbit Diameter: | 3/8" (9.5 mm) | 3/32" (2.4 mm) |
| Tool Spindle Thread: | 5/16"- 24 female | 5/16"- 24 female |
| Length: | 7" (178 mm) | 7" (178 mm) |
| Height: | 3 1/2" (89 mm) | 3 1/2" (89 mm) |
| Weight: | 1.6 lbs. (0.73 kg) | 1.5 lbs. (0.68 kg) |
| Price/Each | \$248.00 | \$248.00 |



3 1/2" NON-VACUUM DYNORBITAL-SPIRIT™ RANDOM ORBITAL SANDERS

- Replaceable drop-in motor
- Palm-style grip; colour coded composite lever (identifies orbit size)
- Low sound levels
- One-piece speed control dial
- Custom engineered composite cylinder; double row balancer bearing keeps out contaminants
- Includes low profile, premium urethane, weight-mated, non-vac pad
- Can be converted easily to self-generated or central vac model for hook-up to dust collection system

| | |
|--------------------------------|---------------------------|
| Model No. | TGY858 |
| Mfg. No. | 59015 |
| Abrasive Information: | 3 1/2" (89 mm) dia. discs |
| Pad Information: | 3 1/2" (89 mm) dia. pad |
| Air Flow Rate @ 90 PSI: | 16 SCFM |
| Sound Level: | 73 dB (A) |
| Horsepower: | 0.25 HP |
| Free Speed: | 12 000 RPM |
| Air Pressure: | 90 PSI |
| Air Inlet Thread: | 1/4 NPT |
| Hose Size (I.D.): | 1/4" (6 mm) |
| Orbit Diameter: | 3/16" (4.8 mm) |
| Tool Spindle Thread: | 5/16"-24 female |
| Length: | 6" (152 mm) |
| Height: | 3 1/2" (89 mm) |
| Weight: | 1.4 lbs. (0.64 kg) |
| Price/Each: | \$248.00 |



3 1/2" NON-VACUUM DYNORBITAL® SUPREME RANDOM ORBITAL SANDERS

- Includes low profile, premium urethane, weight-mated, non-vac pad for use with PSA discs
- Can be converted easily to self-generated vac model for hook-up to dust collection system
- Random circular & elliptical motion produces superior finishes

| | |
|--------------------------------|---------------------------|
| Model No | TGY810 |
| Mfg. No. | 56800 |
| Abrasive Information: | 3 1/2" (89 mm) dia. discs |
| Pad Information: | 3 1/2" (89 mm) dia. |
| Length: | 6" 152 mm |
| Height: | 3 3/4" (95 mm) |
| Weight: | 2.1 lbs. (0.95 kg) |
| Air Flow Rate @ 90 PSI: | 18 SCFM |
| Sound Level: | 76 dB(A) |
| Horsepower: | 0.24 HP |
| Free Speed: | 12 000 RPM |
| Air Pressure: | 90 PSI |
| Air Inlet Thread: | 1/4 NPT |
| Hose Size (I.D.): | 1/4" (6 mm) |
| Orbit Diameter: | 3/16" (4.8 mm) |
| Tool Spindle Thread: | 5/16"-24 female |
| Price/ Each: | \$275.00 |



5" & 6" NON-VACUUM DYNORBITAL® SUPREME RANDOM ORBITAL SANDERS

- Can be converted easily to self-generated vac model for hook-up to dust collection system
- Random circular & elliptical motion produces superior finishes
- Includes low profile, premium urethane, weight-mated, non-vac pad



| Model No. | TGY813 | TGY816 |
|--------------------------------|------------------------|------------------------|
| Mfg. No. | 56815 | 56826 |
| Abrasive Information: | 5" (127 mm) dia. discs | 6" (152 mm) dia. discs |
| Pad Information: | 5" (127 mm) dia. | 6" (152 mm) dia. |
| Air Flow Rate @ 90 PSI: | 18 SCFM | 18 SCFM |
| Sound Level: | 79 dB (A) | 79 dB (A) |
| Horsepower: | 0.28 HP | 0.24 HP |
| Free Speed: | 12 000 RPM | 12 000 RPM |
| Air Pressure: | 90 PSI | 90 PSI |
| Air Inlet Thread: | 1/4 NPT | 1/4 NPT |
| Hose Size (I.D.): | 1/4" (6 mm) | 1/4" (6 mm) |
| Orbit Diameter: | 3/16" (4.8 mm) | 3/16" (4.8 mm) |
| Tool Spindle Thread: | 5/16"-24 female | 5/16"-24 female |
| Length: | 6 1/2" (165 mm) | 7" (178 mm) |
| Height: | 3 5/8" (92 mm) | 3 1/2" (89 mm) |
| Weight: | 2.1 lbs. (0.95 kg) | 2.2 lbs. (1 kg) |
| Price/Each | \$275.00 | \$275.00 |

AIR LINE CONNECTORS

- Swivels 360° at two pivot points allowing the air hose to drop directly to the floor while providing superb tool handling



THZ359



THZ360



THZ361



COMPOSITE DYNASWIVEL® AIR LINE CONNECTORS

| | |
|------------------------------|--------------------|
| Model No. | THZ359 |
| Mfg. No. | 94300 |
| Thread Size: | 1/4" NPT |
| Weight: | 2.15 oz. (0.06 kg) |
| Air Flow Range: | Up to 33 SCFM |
| Maximum Air Pressure: | 150 PSI |
| Price/Each: | \$28.20 |

1/4" NPT HEAVY-DUTY DYNASWIVEL® AIR LINE CONNECTORS

| | |
|-------------------------------|---------------------|
| Model No. | THZ361 |
| Mfg. No. | 95460 |
| Air Inlet Thread Size: | 1/4" NPT |
| Air Flow Range: | Up to 25 SCFM |
| Maximum Air Pressure: | 150 PSI |
| Weight: | 0.20 lbs. (0.09 kg) |
| Price/ Each: | \$39.95 |

COMPOSITE FLOW CONTROL DYNASWIVEL® AIR LINE CONNECTORS

| | |
|------------------------------|-------------------|
| Model No | THZ360 |
| Mfg. No. | 94407 |
| Thread Size: | 1/4" NPT |
| Air Flow Range: | Up to 46 SCFM |
| Maximum Air Pressure: | 150 PSI |
| Weight: | 2.4 oz. (0.08 kg) |
| Price/Each: | \$42.70 |

AIR TOOLS

DYNASTRAIGHT® AIR POWERED ABRASIVE FINISHING TOOLS

- Ideal set-up for Dynacushion® wheel (not included)
- Threaded arbor (5/8" -11) for exclusive use with Dynacushion® pneumatic wheel
- Shown with optional pneumatic wheel

Model No. TGY774
Mfg. No. 13505
Abrasive Information: 15-1/2" long x 3-1/2" wide Dynacushion® belts (394 mm x 89 mm)
Air Flow Rate @ 90 PSI: 44 SCFM
Sound Level: 88 dB (A)
Horsepower: 1.00 HP
Free Speed: 3400 RPM
Air Pressure: 90 PSI
Air Inlet Thread: 3/8 NPT
Hose Size (I.D.): 3/8" (10 mm)
Threaded Arbor: 5/8" - 11 male
Tool Spindle Thread: 1/2" - 20 male
Length: 14 7/8" (378 mm)
Height: 1 7/8" (48 mm)
Weight: 4 lbs. (1.82 kg)
Price/Each: \$1050.00



DYNISHER® FINISHING TOOLS

- Excellent for blending and finishing stainless steel and most other metals, leaving an in-line pattern
- Includes: 3/4" dia. arbor for mounting a variety of abrasives & accessories
- Shown with optional Dynacushion® pneumatic wheel not included

Model No TGY767
Mfg. No. 13450
Abrasive Information: 3-1/2"(84 mm) x 15-1/2"(394 mm) abrasive belts 4" dia. (102 mm) Abrasive flap wheels 4" (102 mm) dia. conditioning discs 42 SCFM
Air Flow Rate @ 90 PSI: 80 dB (A)
Sound Level: 1.00 HP
Horsepower: 2800 RPM
Free Speed: 90 PSI
Air Pressure: 3/8 NPT
Air Inlet Thread: 3/8" (10 mm)
Hose Size (I.D.): 3665 SFPM
Max. SFPM: 3/4" x 2 5/16" (19 mm x 59.5 mm)
Arbor Information: 15" (381 mm)
Length: 7" (178 mm)
Height: 5.7 lbs. (2.59 kg)
Weight: \$1640.00
Price/Each:



DIE GRINDERS STRAIGHT & OFFSET (7°)

- Gearless motor reduces downtime and lessens repair expense compared to geared tools
- Governor-controlled to maintain RPM under heavy load
- Lightweight thermal-insulated housing reduces cold air transmission and vibration to the operator



4" LIGHTWEIGHT DYNINGER® FINISHING TOOLS (1/4" COLLET)

- Mount 4" dia. spindle-mount dry-cut sanding stars with 1/4" shank. Order stars separately
- Tool includes air-flow control Dynaswivel® fitting for maximum tool manoeuvrability and control
- Eliminates raised grain and removes loose fibres when whitewood sanding as well as scuffing sealer coats

Model No TGY792
Mfg. No. 52050
Abrasive Information: -
Order Separately: 3/4", 1", 1-1/2", 2", 3", & 4", dia. sanding stars (19, 25, 38, 51, 76, & 102 mm)
Air Flow Rate @ 90 PSI: 21 SCFM
Sound Level: 81 dB (A)
Horsepower: 0.40 HP
Free Speed: 0 to 3200 RPM
Air Pressure: 90 PSI
Air Inlet Thread: 1/4 NPT
Hose Size (I.D.): 1/4" (6 mm)
Max. SFPM: 3350 SFPM
Tool Spindle Thread: 3/8"-24 male
Length: 8 3/4" (222 mm)
Height Diameter: 2 3/8" (60 mm)
Weight: 2.2 lbs. (1 kg)
Price/Each: \$731.00



| Model No. | TGZ172 | TGZ174 | TGZ175 | TGZ073 |
|------------------------------|-----------|-----------|-----------|-----------|
| Mfg. No. | 52666 | 52668 | 52669 | 48205 |
| Head type | Straight | Straight | Straight | 7° |
| Collet Insert Size: | 1/4" | 1/4" | 1/4" | 1/4" |
| Free Speed (RPM): | 12000 | 18000 | 20000 | 25000 |
| HP (W): | 1.0 (746) | 1.0 (746) | 1.0 (746) | 0.4 (224) |
| Motor Characteristic: | Gearless | Gearless | Gearless | Gearless |
| Exhaust Type: | Rear | Rear | Rear | Rear |
| Wt. lbs.: | 2.3 | 2.4 | 2.4 | 1.5 |
| Price/Each: | 635.00 | 635.00 | 635.00 | 519.00 |

PENCIL GRINDERS 60 000 RPM

- High-speed air motor, controlled with patented governor, provides constant speed under load
- Precision, high-tolerance, low run-out collet. Run-out is a true 0.0002 @ 1" (25 mm) from face
- Super flexible hose for maximum agility

Model No. TGZ034
Mfg. No. 51700
Collet Insert Size: 1/8"
Air Flow Rate @ 90 PSI: 8 SCFM
Sound Level: 66 dB(A)
Motor Characteristic: Oil-Less Turbine
Free Speed: 60000 RPM
Bearing Type: Metal
Exhaust Type: Rear
Weight: 0.6 lbs.
Packaged Weight: 1.6 lbs.
Price/Each: \$568.00



ELECTRIC DYNISHER® FINISHING TOOLS

- 3/4" (19 mm) dia. arbor; pneumatic tire and abrasive sold separately
- Variable speed On/Off switch
- 5/8" - 11 spindle and 3/4" arbor

Model No THZ358
Mfg. No. 51585
Max. RPM: 0-3000 RPM
Voltage: 120 V (AC) Phase: 1
Current: 11 A, 60 Hz Frequency
Length: 17" (468 mm)
Height: 8" (468 mm)
Weight: 9.5 lbs. (3.8 kg)
Price/Each: \$798.00



DYNISHER® FINISHING TOOL VERSATILITY KITS

- Excellent for blending and finishing stainless steel and most other metals, leaving an in-line pattern
- Includes: 3/4" dia. Arbor for mounting a variety of abrasives & accessories
- Shown with optional Dynacushion® pneumatic wheel, not included

Model No TGY768
Mfg. No. 13460
Abrasive Information: 3 1/2"(84 mm) x 15-1/2"(394 mm) Abrasive belts. 4"(102 mm) dia. Abrasive flap wheels. 4"(102 mm) dia. conditioning discs
Air Flow Rate @ 90 PSI: 41 SCFM
Sound Level: 84 dB (A)
Horsepower: 1.00 HP
Free Speed: 2800 RPM
Air Pressure: 90 PSI
Air Inlet Thread: 3/8 NPT
Hose Size (I.D.): 3/8" (10 mm)
Max. SFPM: 3665 SFPM
Arbor Information: 3/4" x 2 5/16" (19 mm x 59.5 mm)
Length: 15" (381 mm)
Height: 7" (178 mm)
Weight: 5.7 lbs. (2.59 kg)
Price/Each: \$1737.00



ELECTRIC RIGHT ANGLE POLISHERS

- Double-Insulated tool housing for protection against electric shock; variable speed control and with feather-touch trigger
- Lock in desired speed with Lock-Set button; Easy removal of backing pad with Locking-Head
- Two-hand control for addition comfort when working in vertical positions; Simple brush replacement



Shown with optional backing pad

Model No TGY974
Mfg. No. 51580
Abrasive Information: 5-8" dia. buffs (127-203 mm) 6"-8" dia. (127-203 mm) 88 dB (A)
Pad Information: 6"-8" dia. (127-203 mm) 88 dB (A)
Sound Level: 88 dB (A)
Voltage: 120 V (AC) Phase: 1
Current: 11 Amps Frequency: 60 Hz
Horsepower: 1.12 HP
Free Speed: 0 - 3000 RPM
Tool Spindle Thread: 5/8" - 11 Male
Length: 17" (423 mm)
Height: 5 1/4" (127 mm)
Weight: 7.8 lbs. (3.2 kg)
Price/Each: \$405.00



CLECO® HERITAGE 236 SERIES - INLINE GRINDERS

- Abrasive capacity: 1" carbide burr or 2" wheel
- Engineered for heavy duty applications in the most demanding environment
- Robust and efficient 0.9 HP (0.7 kw) motor
- Lightweight and rugged alloy housing
- Performance rated @ 90 PSI / 620 kPa air pressure
- Air consumption: 16 CFM
- Air inlet: 1/4"
- Collet size: 1/4"



TYM407

CLECO® HERITAGE 25 SERIES - EXTENDED GRINDERS

- Powerful 1.4 HP (1.0 kw) motor
- Lightweight and rugged alloy housing
- Engineered for heavy duty applications in the most demanding environment
- Performance rated @ 90 PSI / 620 kPa air pressure
- Air consumption: 16 CFM
- Air inlet: 3/8"
- Tool length: 14.4"



TYM439



| Model No. | Mfg. No. | Exhaust Location | Tool Length" | No Load RPM | Price /Each |
|-----------|---------------|------------------|--------------|-------------|-------------|
| TYM407 | 236GLF-250-C4 | Front | 6.8 | 25 000 | 790.00 |
| TYM421 | 236GLR-250-C4 | Rear | 7.4 | 25 000 | 872.00 |
| TYM430 | 236GLS-240-C4 | Side | 6.8 | 24 000 | 809.00 |



| Model No. | Mfg. No. | Abrasive Capacity | Collet Size" | No Load RPM | Price /Each |
|-----------|-----------------|-----------------------------|--------------|-------------|-------------|
| TYM442 | 25GELC-180-C4 | 1" Carbide Burr or 2" Wheel | 1/4 | 18 000 | 1678.00 |
| TYM440 | 25GELC-140-P3T | 1.25" Cone or Plug Wheel | 3/8 | 14 000 | 1684.00 |
| TYM439 | 25GELC-120-W3T4 | 4" Type 1 | 3/8 | 12 000 | 1741.00 |

AIR TOOLS

CLECO® 19 SERIES - STALL SCREWDRIVERS

- Tool weight: 1.16 lbs.
- Tool length: 5.9"
- Free speed: 1100 RPM
- Max Torque: 40 in.-lbs.
- Engineered for heavy duty applications in the most demanding environment
- Adjustable reverse lever for true one-hand - left-handed or right-handed - operation
- Trigger start
- "P" handle style
- Interchangeable soft-touch grip sizes
- Air consumption: 11 CFM
- Air inlet: 1/4"
- Sound level (dBA): 80
- Chuck Size: 1/4"
- Chuck Type: Keyless

Model No. TYN249
Mfg. No. 19PTS04Q
Price/Each \$1090.00



Cleco®

CLECO® 19 SERIES - PISTOL GRIP SCREWDRIVERS W/ADJUSTABLE TORQUE SETTINGS

- Tool weight: 1.41 lbs.
- Tool length: 8.0"
- Free speed: 1100 RPM
- Max Torque: 40 in.-lbs.
- Engineered for heavy duty applications in the most demanding environment
- Class-leading accuracy and repeatability
- Adjustable reverse lever for true one-hand - left-handed or right-handed - operation
- "P" handle style
- Interchangeable soft-touch grip sizes
- Trigger and Push & Trigger start
- External torque adjustment from 10 - 40 in.-lbs.
- Air consumption: 11 CFM
- Air inlet: 1/4"
- Sound level (dBA): 80
- Chuck Size: 1/4"
- Chuck Type: Keyless

Model No. TYN248
Mfg. No. 19PTA04Q
Price/Each \$1614.00



Cleco®

CLECO® RIGHT ANGLE GRINDERS

- Compact, yet powerful motor
- Reversible safety lever throttle
- Dual auxiliary handle positions
- Maximum material removal for a right angle grinder
- Streamlined all metal housing
- Performance rated @ 90 PSI / 620 kPa air pressure
- Air consumption: 15 CFM
- Air inlet: 1/2"
- No load RPM: 12 000



Cleco®

| Model No. | Mfg. No. | Wheel Size" | Spindle Size | Motor Power HP | Price /Each |
|--------------------|----------------|-------------|--------------|----------------|----------------|
| 1660 SERIES | | | | | |
| TYM371 | 1660AGL-04 | 4 | 3/8" | 1.6 | 958.00 |
| TYM374 | 1660AGL-45 | 4 1/2 | 5/8" | 1.6 | 958.00 |
| TYM372 | 1660AGL-05 | 5 | 5/8" | 1.6 | 958.00 |
| TYM373 | 1660AGL-05-M14 | 5 | M14 | 1.6 | 958.00 |
| 2260 SERIES | | | | | |
| TYM396 | 2260AGL-06 | 6 | 5/8" | 2.2 | 1256.00 |
| TYM397 | 2260AGL-07 | 7 | 5/8" | 2.2 | 1256.00 |

CLECO® CWC PREMIUM COMPOSITE SERIES - IMPACT WRENCHES

- The ultimate balance of performance, ergonomics and durability
- Composite housing with a high output motor that delivers a maximum power-to-weight ratio
- On hand push button forward/reverse with variable speed trigger, dial speed settings
- Twin hammer impact mechanism



TYN507

Cleco®

| Model No. | Mfg. No. | Air Consumption CFM | Retainer Type | Drive" Drive" | Impacts Per Minute | Free Speed RPM | Max Torque ft.-lbs. | Price /Each |
|---------------|-----------|---------------------|--------------------|---------------|--------------------|----------------|---------------------|---------------|
| TYN508 | CWC-250QC | 2.7 | Quick Change Chuck | 1/4 | 1200 | 13 000 | 50 | 237.00 |
| TYN507 | CWC-250R | 2.7 | Ring | 1/4 | 1200 | 13 000 | 50 | 237.00 |
| TYN501 | CWC-375R | 5.3 | Ring | 3/8 | 1600 | 10 000 | 450 | 447.00 |
| TYN503 | CWC-375P | 5.3 | Pin | 3/8 | 1600 | 10 000 | 450 | 447.00 |
| TYN509 | CWC-500R | 5.7 | Ring | 1/2 | 1250 | 8000 | 800 | 473.00 |
| TYN512 | CWC-500P | 5.7 | Pin | 1/2 | 1250 | 8000 | 800 | 473.00 |
| TYN511 | CWC-500RE | 5.7 | Ring* | 1/2 | 1250 | 8000 | 800 | 523.00 |
| TYN514 | CWC-500PE | 5.7 | Pin* | 1/2 | 1250 | 8000 | 800 | 505.00 |
| TYN505 | CWC-750P | 9.7 | Pin | 3/4 | 1200 | 6500 | 1400 | 971.00 |

*Extended anvil

CLECO® CWM PREMIUM METAL SERIES - IMPACT WRENCHES

- Engineered for heavy duty applications in the most demanding environment
- Rugged all-metal construction
- Withstands heavy abuse with twin impact mechanism
- Large lever forward/reverse and speed settings with variable speed trigger
- Soft touch grip protects against slip, temperature and vibration



TYN499

Cleco®

| Model No. | Mfg. No. | Air Consumption CFM | Retainer Type | Drive" Drive" | Impacts Per Minute | Free Speed RPM | Max Torque ft.-lbs. | Price /Each |
|---------------|----------|---------------------|---------------|---------------|--------------------|----------------|---------------------|---------------|
| TYN496 | CWM-375R | 3.8 | Ring | 3/8 | 1400 | 12 000 | 340 | 381.00 |
| TYN497 | CWM-375P | 3.8 | Pin | 3/8 | 1400 | 12 000 | 340 | 381.00 |
| TYN499 | CWM-500R | 5.6 | Ring | 1/2 | 1200 | 9000 | 850 | 421.00 |
| TYN500 | CWM-500P | 5.6 | Pin | 1/2 | 1200 | 9000 | 850 | 421.00 |
| TYN498 | CWM-750P | 7.6 | Pin | 3/4 | 1200 | 6000 | 1350 | 932.00 |

DOTCO® 15LF SERIES - RIGHT ANGLE DRILLS

- Tool weight: 1.7 lbs.
- Tool length: 11.0"
- Motor power: 0.4 HP (0.30 kW)
- Engineered for heavy duty applications in the most demanding environment
- Reinforced angle head for added durability
- Comfortable and ergonomic handle
- Performance rated @ 90 PSI / 620 kPa air pressure
- Air consumption: 22 CFM
- Air inlet: 1/4"
- Sound level (dBA): 80
- Chuck Size: 1/4"
- No load RPM: 3700

Model No. TYM161
Mfg. No. 15LF281-52
Price/Each \$1422.00

DOTCO®



DOTCO® 12-10 SERIES - INLINE COLLET GRINDERS

- Tool weight: 0.8 lbs.
- Tool length: 6.0"
- Motor power: 0.3 HP (0.22 kW)
- Abrasive capacity: 1/2" carbide burr or 1" mounted wheel
- Durable and ergonomic composite housing
- Compact size for ultimate control - easy access to confined areas
- Ideal for die and mold work as well as deburring
- Standard equipped with lock-off lever
- Performance rated @ 90 PSI / 620 kPa air pressure
- Air consumption: 16 CFM
- Air inlet: 1/4"
- Sound level (dBA): 81
- Collet size: 1/4"
- No load RPM: 25 000

DOTCO®

| Model No. | Mfg. No. | Exhaust Location | Price /Each |
|---------------|------------|------------------|---------------|
| TYL601 | 12L1003-36 | Front | 474.00 |
| TYL620 | 12L1082-36 | Rear | 514.00 |



TYL601

DOTCO® 12-25 SERIES - INLINE COLLET GRINDERS

- Tool weight: 1.8 lbs.
- Tool length: 7.3"
- Motor power: 0.9 HP (0.67 kW)
- Abrasive capacity: 1" carbide burr or 1.5" mounted wheel
- Ergonomic composite housing
- High power-to-weight ratio for optimal productivity
- Ideal for die and mold work as well as deburring
- Performance rated @ 90 PSI / 620 kPa air pressure
- Air Consumption: 38 CFM
- Air Inlet: 1/4"
- Sound Level (dBA): 81
- Collet Size: 1/4"

DOTCO®

| Model No. | Mfg. No. | Exhaust Location | No Load RPM | Price /Each |
|---------------|------------|------------------|-------------|---------------|
| TYL718 | 12L2500-01 | Front | 23 000 | 666.00 |
| TYL741 | 12L2582-01 | Rear | 18 000 | 696.00 |



TYL718

DOTCO® 12LF SERIES - RIGHT ANGLE GRINDERS

- Tool weight: 1.1 lbs.
- Tool length: 6.6"
- Motor power: 0.4 HP (0.29 kW)
- Abrasive capacity: 1/2" carbide burr or 1" mounted wheel
- Ergonomic composite housing
- Ergonomic and balanced design minimizes operator fatigue
- Engineered for heavy duty applications in the most demanding environment
- Suitable for wide range of finishing and deburring applications
- Performance rated @ 90 PSI / 620 kPa air pressure
- Air inlet: 1/4"
- Sound level (dBA): 79
- Collet size: 1/4"

DOTCO®

| Model No. | Mfg. No. | Air Consumption CFM | Exhaust Location | No Load RPM | Price /Each |
|---------------|------------|---------------------|------------------|-------------|---------------|
| TYL839 | 12LF201-36 | 9 | Front | 20 000 | 818.00 |
| TYL847 | 12LF280-36 | 11 | Rear | 12 000 | 818.00 |



TYL839

DOTCO® 10-90 SERIES - PRECISION TURBINE GRINDERS

- Tool weight: 0.5 lbs.
- Tool length: 5.4"
- Motor power: 0.06 HP (0.044 kW)
- Requires no air line lubrication - High precision ball bearings for long life expectancy
- Two-stage turbine motor with roll throttle
- Achieves a superb finish with its high speed and precision spindle
- Lightweight and durable aluminum housing
- Low vibration and quiet operation minimizes operator fatigue
- CAUTION: Use dry air at 90 PSI maximum: Do not lubricate turbine grinders. Lubrication will be detrimental to the operation and life of turbine tools
- Air consumption: 6 CFM
- Air inlet: 1/8"
- Sound level (dBA): 75
- Collet size: 1/8"
- No load RPM: 100 000

Model No. TYL572
Mfg. No. 10R9000-08
Price/Each \$812.00

DOTCO®



DOTCO® 15Z SERIES - AIR MARKING PEN

- Tool weight: 0.3 lbs.
- Tool length: 5.5"
- Free speed: 20 000 RPM
- Abrasive capacity: 1/8" stylus
- Motor power: 0.06 HP (0.044 kW)
- Sliding sleeve throttle
- Ideal for marking a variety of materials, ranging from aluminum to titanium
- Carbide tipped stylus
- Engineered for heavy duty applications in the most demanding environment
- Air consumption: 9 CFM
- Air inlet: 1/4"
- Sound level (dBA): 80

Model No. TYN251
Mfg. No. 15Z-710
Price/Each \$565.00

DOTCO®



DOTCO® NON REVERSIBLE DRILLS

- Equipped with Jacobs® geared chuck and chuck key
- Ergonomically critical finger and thumb guides for the hand to aid control
- Excellent for aerospace, metal fabrication, and wood working application
- Performance rated @ 90 PSI / 620 kPa air pressure
- Drill diameter capacity matches chuck size
- Air consumption: 38 CFM
- Air inlet: 1/4"
- Sound level (dBA): 80
- Chuck Type: Keyed



TYM017

DOTCO®

| Model No. | Mfg. No. | Motor Power | Chuck Size" | Free Speed RPM | Price /Each |
|--------------------|------------|------------------|-------------|----------------|---------------|
| 14CS SERIES | | | | | |
| TYM084 | 14CSL92-38 | 0.6 HP (0.67 kW) | 1/4 | 3200 | 869.00 |
| TYM088 | 14CSL95-51 | 0.6 HP (0.67 kW) | 3/8 | 1300 | 971.00 |
| 14CF SERIES | | | | | |
| TYM017 | 14CFS91-51 | 0.4 HP (0.30 kW) | 3/8 | 5200 | 712.00 |
| TYM021 | 12CFS92-51 | 0.4 HP (0.30 kW) | 3/8 | 3800 | 712.00 |

DOTCO® 10-04 SERIES - PRECISION PENCIL GRINDERS

- Tool weight: 0.2 lbs.
- Tool length: 5.8"
- Motor power: 0.1 HP (0.074 kW)
- Industrial bearing provides long life expectancy
- Designed for precision deburring and metal removal
- Compact and light aluminum weight housing
- Roll throttle equipped
- Tool requires lubricated airline at 90 PSI maximum
- Air consumption: 9 CFM
- Air inlet: 1/8"
- Sound level (dBA): 78
- Collet size: 1/8"
- No load RPM: 60 000

Model No. TYL565
Mfg. No. 10R0401-18
Price/Each \$685.00

DOTCO®





TIRE PRESSURE GAUGES

TOPRING

All pencil gauges have a precision engineered brass chuck to assure gauge fits squarely on the valve. This prevents air leakage and guarantees accurate pressure readings. All gauges have a permanent deflating pin to release excessive air.

STANDARD TIRE GAUGES (NYLON BAR PENCIL TYPE)

- Double calibration
PSI: 5 to 50
- kPa: 50 to 350
- Ideal for automobile and light trucks

Model No. TA888
Mfg. No. 63.400C
Price/Each \$6.53



HIGH PRESSURE TIRE GAUGES (NYLON BAR PENCIL TYPE)

- Double calibration
PSI: 10 to 120
- kPa: 90 to 820
- For high pressure bicycle and motorcycle tires

Model No. TA889
Mfg. No. 63.410C
Price/Each \$7.49



TIRE PRESSURE GAUGES - DUAL WHEEL TYPE

TOPRING

All dual-wheel truck tire gauges have precision-engineered brass chuck guides to assure gauge fits squarely on the valve. This prevents air leakage and guarantees accurate pressure reading.

PISTOL GRIP DIAL INFLATOR GAUGES

- Large 2.5" dial for accurate reading 0-90 PSI
- Nitrogen compatible
- 15" rubber hose
- 1/4 (M) NPT Air Inlet



DUAL FOOT TIRE GAUGES (ALUMINUM BAR)

- Double calibration
- PSI: 10 to 160
- Kg: 1 to 11

Model No. TNB064
Mfg. No. 63.545C
Price/Each \$25.30



DUAL STRAIGHT CHUCK TIRE GAUGES (NYLON BAR)

- Straight-on chuck head with a 30° reverse angle for tandem wheels
- PSI: 10 to 150
- kPa: 100 to 1000

Model No. TNB063
Mfg. No. 63.570C
Price/Each \$27.90

| Model No. | Mfg. No. | Description | Price/Each |
|-----------|----------|---------------------|------------|
| TNB060 | 63.710 | Dual Foot Air Chuck | 56.50 |
| BC317 | 63.711 | Clip-On Air Chuck | 56.10 |

PROFESSIONAL DIAL TIRE GAUGES

- Large 3.5" dial for accurate reading 10-170 PSI
- 20" rubber hose
- Nitrogen compatible
- Swivel clip-on air chuck

Model No. BU129
Mfg. No. 63.585C
Price/Each \$76.10



AIRPRO INFLATOR GAUGES

- Large 2.5" dial for accurate reading 0-174 PSI
- Three functions: inflation, deflation and pressure measurement
- Nitrogen compatible
- 72" rubber hose
- Air inlet 1/4 (F) NPT
- Includes two interchangeable chucks

Model No. BU133
Mfg. No. 63.651
Price/Each \$135.00



PROFESSIONAL INFLATOR GAUGES

- Large 3.5" dial for accurate reading 0-90 PSI
- Nitrogen compatible
- 39" rubber hose
- Air inlet 1/4 (M) NPT

Model No. TNB058
Mfg. No. 63.691
Price/Each \$139.00



PROFESSIONAL INFLATOR GAUGES FOR HEAVY VEHICLES

- Designed for heavy vehicles
- Large 3.5" dial for accurate reading 0-170 PSI
- Nitrogen compatible
- 78" rubber hose
- Air inlet 1/4 (M) NPT

Model No. TNB059
Mfg. No. 63.692
Price/Each \$139.00



DIGITAL PISTOL GRIP DIAL INFLATOR GAUGES

TOPRING

- Large 3.5" dial with LCD display for reading from 0-218 PSI
- Four pressure reading measures PSI, BAR, KFG and KPA
- Nitrogen compatible
- 39" rubber hose
- Air inlet 1/4 (F) NPT

Model No. TNB061
Mfg. No. 63.661
Price/Each \$121.00



INFLATOR GAUGES

- Easy to read 2" dial from 10-220 PSI
- Nitrogen compatible
- 12" rubber hose
- Air inlet 1/4 (F) NPT
- With clip-on chuck

Model No. TNB472
Mfg. No. 63.659C
Price/Each \$39.10



STANDARD AIR CHUCKS

TOPRING

For regular live air lines. These chucks have a built-in shutoff valve and will not work on inflator gauges.

LOCK-ON AIR CHUCKS (CLOSED)

- Firmly locks onto valve when pushed forward
- 1/4" (F) NPT

Model No. TA877
Mfg. No. 63.100C
Price/Each \$21.40



DUAL FOOT AIR CHUCKS

- 1/4" (F) NPT
- 6" long

Model No. TA881
Mfg. No. 63.140C
Price/Each \$8.71



DUAL FOOT AIR CHUCKS

- For hard-to-reach valves
- 1/4" (F) NPT
- 13" long

Model No. TA882
Mfg. No. 63.150C
Price/Each \$17.90



TILT LOCK DUAL FOOT AIR CHUCKS (CLOSED)

- Straight-on chuck with threaded, deep wheel lock nuts which lock onto valve mouth when tilted
- 6" and 1/4 (F) NPT
- 14" and 1/4 (F) NPT (extended TA884)

Model No. TA883
Mfg. No. 63.160C
Price/Each \$14.90

Model No. TA884
Mfg. No. 63.170
Price/Each \$20.40



HEX BALL FOOT AIR CHUCKS

- 3/4" hex
- 1/4" (F) NPT

Model No. TA879
Mfg. No. 63.130C
Price/Each \$4.86



TOPRING

LIQUID TRANSFER & CLEAN-UP SYSTEMS

Fills a 55-gal. (205 L) drum in less than 2 minutes without electricity - eliminates shop vac liquid handling.

- Transforms an ordinary 55-gal. drum into a liquid vacuum cleaner; a simple two-way valve and 80-100 PSI air allows pumping to a sealed drum
- Easily picks up high-viscosity liquids, chip, granulated products
- Ideal for paint, coolant, oils - any non-flammable liquids
- Safe in wet areas, no electricity; requires only compressed air
- Lightweight, portable, easily transferred to another drum in minutes
- Stainless steel construction
- No moving parts, no motor or hand crank, maintenance-free
- Instant On/Off control from air valve
- Easy to clean
- No spills; overflow protected with automatic valve
- Complete system includes vacuum unit, 12' hose with tapered PVC couplings, PVC tapered hose bung, extension tubes, crevice tool, skimmer tool, round brush
- Drum not included

Model No TG142 Complete kit
Mfg. No. 67.400
Price/Each \$918.00



TG143

TG142
Drum not included

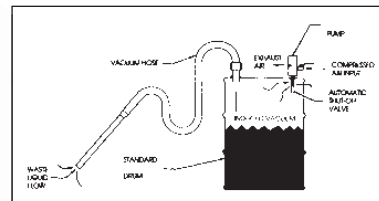
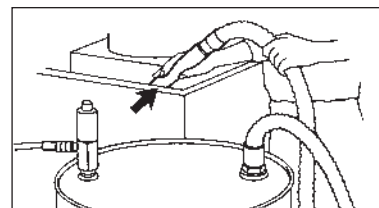

SPARE PARTS

| Model No. | Mfg. No. | Description | Price/Each |
|-----------|----------|--------------------|------------|
| TG143 | 67.410 | Vacuum/pump unit | 735.00 |
| TG144 | 67.415 | 10' suction hose | 132.00 |
| TG145 | 67.420 | Squeegee | 99.90 |
| TG146 | 67.425 | 19" extension tube | 33.80 |

| Model No. | Mfg. No. | Description | Price/Each |
|-----------|----------|----------------------|------------|
| TG147 | 67.430 | Male drum adaptor 2" | 53.90 |
| TG148 | 67.435 | Crevice tool | 26.60 |
| TG149 | 67.440 | Round brush | 38.50 |
| TG150 | 67.445 | Skimmer | 24.80 |

TOPRING

QUIKVAC AIR VACUUM & BLOW GUN KITS

- Provides the operator with both a vacuum and a blow gun in a hand held, easy to use model
- A low cost solution to a wide variety of industrial applications
- Lightweight and easy to use
- The trigger switch is used for on/off
- Four different size vacuum accessories fits all jobs
- Complete kit with gun, accessories and vacuum bag
- 1/4 (F) NPT inlet and operates at 90 PSI

Model No. TNB066
Mfg. No. 67.200
Price/Each \$86.40



GUNVAC VACUUM GUN KITS

- Will quickly clean up metal chips, dust, glass, cloth scraps, plastic trim, paper, rubber and other residues
- Total cleaning versatility without electricity or moving parts
- Inexpensive
- Lightweight and easy to use
- Venturi Jet creates a powerful vortex which multiplies input air flow more than 12-fold
- Complete kit with gun, accessories and vacuum bag
- 1/4 (F) NPT inlet and working pressure 60 to 125 PSI

Model No. TG151
Mfg. No. 67.050
Price/Each \$184.00



TOPRING

TOPRING

GUN-VAC VACUUM UNITS

The most powerful pneumatic Gun-Vac available and it handles like a blow gun. Vacuums metal chips, debris, sawdust, pellets, trimmings, and crumbs instead of blowing them. Sumps can be drained by removing the bag and connecting vac to a drum with a hose. It has no electrical fields or wires. Kit comes complete with 9" crevice tool. Constructed of rugged aluminum, it has a 1/4" NPT inlet and operates at 80-160 PSI. Tapered vacuum inlet accepts all standard 1-1/4" vac ccessories.

Model No. TB155
Mfg. No. 1500
Price/Each \$163.00



GUARDAIR

MAXPRO GRAVITY FED SAND BLASTERS

- High pressure blasting force for powerful cleaning
- Material control valve meters sand flow precisely
- Spot blast system included
- Ceramic nozzle
- 1/4 (F) NPT inlet

Model No. TKZ834
Mfg. No. 61.040
Price/Each \$126.00



TOPRING

AIR TOOLS & ACCESSORIES



AIR BLOW GUNS

- Contoured body fits comfortably in the operators hand and made to protect the palm of the hand against the connection fittings
- Curved tip 5" long
- 1/4" (F) - 18 NPT Air Inlet

Model No. TLZ146
Price/Each \$11.25

aurora tools®



MAXJET INTERCHANGEABLE TIP BLOW GUN KITS

- Each tip fits both blow gun bodies with a convenient, quick coupler style connection
- Ergonomic blow gun body provides a narrow, high velocity jet of air

INCLUDED IN THE KIT:

- Plastic-body ergonomic blow gun with quick coupler style connection for tips
- Compact metal blow gun with quick coupler style connection for tips
- 1/4 industrial plug, 1/4 (M) NPT
- Plastic safety tip
- Safety booster tip
- Rubber tip
- Inflator needle
- Aerosol spray nozzle
- Siphon tip
- 3 inch needle extension tip
- 4 inch extension tip
- 6 inch safety extension

Model No. TKZ833
Mfg. No. 60.550
Price/Each \$60.20

BLOW GUN W/RUBBER TIP ONLY

Model No. TNB470
Mfg. No. 60.322
Price/Each \$10.60

TOPRING



HEAVY-DUTY AIR BLOW GUN, 7-PC. KITS

- Impact and weather resistant nylon body
- Ergonomic soft rubber grip
- Variable speed trigger controls the amount of air dispensed
- Brass threaded air inlet ensures that threads do not shear
- Silent operation with noise level under 80 dB
- 1/4" (F) - 18 NPT air inlet
- Maximum working pressure: 235 PSI
- Operating temperature: -10° C to 70° C

INCLUDED IN THE KIT:

- Heavy-duty safety blow gun w/4 1/2" long S.S. nozzle
- 4" protective shield provides safety from projectiles
- Soft rubber star tip nozzle for use on delicate materials
- Venturi nozzle for turbo charging output
- 1/2" rubber tip for blowing out lines and cavities
- 1" rubber tip for blowing out lines and cavities
- 1 3/8" rubber tip for blowing out lines and cavities

Model No. TYB523
Price/Each \$6.25

aurora tools®



HEAVY-DUTY BLOW GUNS

- Impact and weather resistant nylon body
- Ergonomic soft rubber grip
- Variable speed trigger controls the amount of air dispensed
- Brass threaded air inlet ensures that threads do not shear
- Silent operation with noise level under 80 dB
- 1/4" (F) - 18 NPT air inlet
- Maximum working pressure: 235 PSI
- Operating temperature: -10° C to 70° C



aurora tools®

| Model No. | Comes with | Noise Level at 100 PSI | Price/Each |
|-----------|---|------------------------|------------|
| TYB519 | - | 77 | 24.45 |
| TYB520 | Snub Nose Rubber Tip | 77 | 28.00 |
| TYB521 | 4 1/2" Long Stainless Steel Nozzle | 80 | 28.00 |
| TYB522 | 5 1/2" Long Stainless Steel Nozzle and Silencer | 75 | 34.55 |

AIRPRO SAFETY BLOW GUNS W/VENTURI TIP

Features

- Specially designed to project a large volume of air at low velocity
- Venturi function increases the amount of inlet air by 250%

Applications

- Automotive and industrial applications
- Ideally suited for moving a large volume of chips or drying or cooling

Model No. UW573 Mfg. No. 60.386 Price/Each \$34.80



AIRPRO BLOW GUNS

Features

- Powerful air stream

Applications

- Ideal for cleaning equipment in industries, as well as automobile repair shops

WITH ANGLED TUBE

Model No. UW577

Mfg. No. 60.390

Price/Each \$18.30



AIRPRO QUIET SAFETY BLOW GUNS

Features

- Specially designed to keep noise level under 75 dB

Applications

- Ideal for automotive and industrial cleaning applications
- Ideal for the electronics industry, repair shops or other industries requiring a low noise level and precise control of air flow

Model No. UW574 Mfg. No. 60.387 Price/Each \$37.30



AIRPRO BLOW GUNS W/THROTTLE SCREW

Features

- Adjustable knob controls the amount of air supplied
- Ergonomic design reduces hand fatigue

Applications

- Ideal for cleaning equipment in industries, as well as automobile repair shops
- Perfect for uses where reduced air flow is required

Model No. UW579 Mfg. No. 60.392 Price/Each \$42.60



AIRPRO QUIET SAFETY BLOW GUNS W/THROTTLE SCREW

Features

- Specially designed to keep noise level under 75 dB

Applications

- Ideal for automotive and industrial cleaning applications
- Ideal for the electronics industry, repair shops or other industries requiring a low noise level and precise control of air flow

Model No. UW575 Mfg. No. 60.388 Price/Each \$52.30



AIRPRO LONG TIP BLOW GUNS

Features

- 12" or 20" long tip
- Ideal for cleaning places which are not easily accessible

Applications

- Ideal for cleaning motors, equipment and machinery in industrial and agricultural sectors

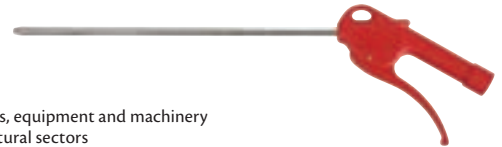

AIRPRO QUIET SAFETY BLOW GUNS W/LIMITED PRESSURE OF 30 PSI

Features

- Meets the safety requirements of OSHA and other health and safety agencies' strictest norms
- Reduction valve in the handle of the blow gun limits the pressure to 30 PSI
- Pressure is controlled so that it does not exceed 30 PSI as recommended by OSHA and other safety agencies' requirements

Applications

- For cleaning equipment where maximum safety is required
- For very delicate operations requiring small quantity of air

Model No. UW576 Mfg. No. 60.389 Price/Each \$51.40

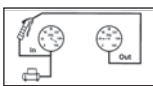

30 PSI

TOPRING

AIRPRO BLOW GUNS

This model does not have a safety by-pass and must be used on airlines which have a pressure regulator set at 30 PSI maximum to conform to OSHA requirements.

Characteristics

- A very compact gun with exclusive features
- The gun works by simply bending the body made from pure Buna-N rubber and automatically stops by simply releasing the body back to a straight position
- The contoured body lies perfectly in the palm of the hand and with only one finger you can operate the progressive valve which adjusts the flow with a sensitive and gradual manner
- The body is made to protect the palm of the hand against the connection fittings
- Especially indicated for specialized fields such as: car repair, aviation etc... where compact size, progressive flow and anti-scratch materials are required

Specifications

- Working temperature: -4°F to 176°F (-20°C to 80°C)
- Maximum working pressure: 150 PSI

Applications

- Air, water, oil, grease, glue
- Fluids compatible with Buna-N rubber

BY-PASS TIP SAFETY BLOW GUNS

- Eliminates risk if hole is obstructed

Model No. TA835

Mfg. No. 60.350

Price/Each \$32.50

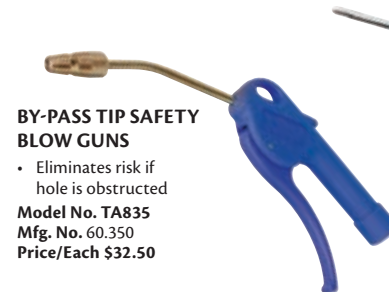

5" BASIC BLOW GUNS

- Curved tip 5" long

Model No. TA831

Mfg. No. 60.320

Price/Each \$19.80



TOPRING

12" BASIC BLOW GUNS

- Straight tip 12" long

Model No. TA832

Mfg. No. 60.325

Price/Each \$34.50

RUBBER TIP BLOW GUNS

- Anti-scratch tip
- Will not scratch or mark surfaces

Applications

- Used in automotive and industrial shops for blowing out blocked passages such as automatic transmissions, carburetors, moulds and dies

Model No. TA833

Mfg. No. 60.330

Price/Each \$23.90



AIR TOOLS & ACCESSORIES

BLIND HOLE AIR GUNS

The most effective blind hole air gun available, it is ideal for both deep crevices and blind holes.

This air gun is 100% effective in delivering a high velocity jet of air to flush out chips and dirt. It has a small diameter air tube to access into holes down to 1/8" diameter, a 1/4" NPT air inlet, and a maximum operating pressure of 120 PSI. Safety air shield provides effective chip-guarding as required by OSHA. Pistol grip casting and angled extension make this light weight air gun easy to handle. It has a 4" straight extension and a 2" extension after the 45 degree bend.

Model No. TB136
Mfg. No. 74BH006Z
Price/Each \$43.90

GUARDAIR®

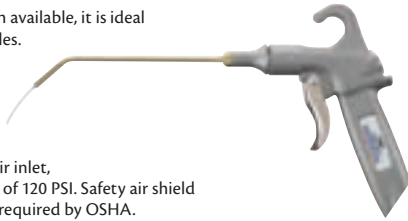

JET GUARD® SAFETY AIR GUNS

Ideally suited for machine shop and production line operation, it provides for years of dependable, non-fatiguing, effective operation. It incorporates a protective air cone which is recognized by OSHA as an effective safeguard for reducing injury from flying chips. An operator controlled knurled adjusting nut to control air volume. Air thrust can be set for whisper or blast.

Model No. TB137
Mfg. No. 74SK
Price/Each \$40.50

GUARDAIR®



WHISPER JET® SAFETY AIR GUNS

The quietest safety air gun available has a unique nozzle with a serrated periphery that reduces noise levels 6-20 dB less than conventional air guns. Solid conical tip design prevents blockage of nozzle, has a 1/4" NPT inlet with a maximum operating pressure of 150 PSI meets NPT standard.

Model No. TB151
Mfg. No. 80WJ
Price/Each \$40.60

GUARDAIR®



SYPHON SPRAY GUNS

The most economical spray gun available. Ideal for spraying thin and medium solutions such as oils, solvents, insulating compounds, metal preservatives and coatings. Operates on compressed air with no moving electrical parts. The high vacuum syphon delivers up to 16 gallons per hour, has a 1/4" NPT inlet and maximum operating pressure of 150 PSI meets OSHA standards. It includes a 12" extension for reaching difficult, hard to reach locations, 6 feet of feed tube and sinker, and an adjustable trigger and nozzle tip to control volume and spray pattern.

Model No. TB152
Mfg. No. 79SG012
Price/Each \$116.00

GUARDAIR®

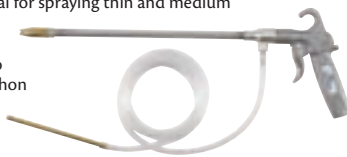

SYPHON SPRAY GUN KITS

- High vacuum syphon delivers up to 12 gallons per hour, knurled adjusting nut controls air volume
- Both 6" and 12" extensions allow for a longer reach
- One quart metal screw-on canister eliminates feed tubes and buckets
- 1/4" FNPT inlet
- Includes: Gun, canister, 6" rigid and 12" flexible plastic spray nozzles
- Conforms to MIL-G-952 type 1
- Meets OSHA standards



GUARDAIR®

| Model No. | Mfg. No. | Description | Price/Each |
|-----------|----------|----------------------|------------|
| TLZ783 | 79SGM | Siphon Spray Gun Kit | 237.00 |

XTRA-THRUST® SAFETY AIR GUNS

The most powerful safety air gun available, it is designed to quickly move large volumes of debris. The Venturi tip increases thrust, with a 1/4" inlet and a maximum operating pressure of 150 PSI, resulting in a very high volume of air that equals 1/2" open pipe in effectiveness, yet meets OSHA standard with a limit of 30 PSI dead end static pressure. Constructed with rugged, cast aluminum body and full length trigger. For maximum performance of XTRA Thrust Air Gun high flow couplers and connectors of 5/16" interior diameter are recommended, as opposed to 3/16" I.D. for standard couplers and connectors.



GUARDAIR®

| Model No. | Mfg. No. | Overall Length" | Price /Each |
|-----------|-----------|-----------------|-------------|
| TB138* | 75XXT | 6 | 47.10 |
| TB139 | 75XT012AA | 12 | 58.60 |
| TB140 | 75XT024AA | 24 | 63.30 |
| TB141 | 75XT036AA | 36 | 67.60 |
| TB142 | 75XT048AA | 48 | 73.40 |
| TB143 | 75XT060AA | 60 | 78.20 |
| TB144 | 75XT072AA | 72 | 97.90 |

* Includes air gun and nozzle only

HIGH FLOW CONNECTORS FOR XTRA-THRUST

| Model No. | Description | Price /Each |
|-----------|-------------------------------------|-------------|
| TB156 | Connector, male 1/4" NPT 5/16" I.D. | 5.82 |
| TB158 | 1/4" hose barb for 1/4" hose | 39.10 |
| TB159 | 3/8" hose barb for 3/8" hose | 35.90 |

LONG JOHN SAFETY AIR GUNS

The longest safety air gun available, it is ideal for cleaning areas that are hard to reach. Long John air guns are used for blowing floor debris into piles, cleaning masonry forms, tanks, ovens, large molds, pipelines, rafters as well as heavy machinery and storage areas. These air guns meet OSHA standards, has a 1/4" NPT inlet with a maximum operating pressure of 150 PSI. The pistol grip casting and aluminum extension make Long John lightweight and easy to handle. Special Venturi tip increases thrust by 200%.

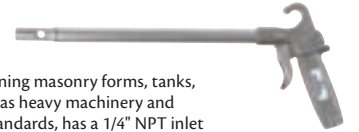

GUARDAIR®

| Model No. | Mfg. No. | Extension Length" | Price /Each |
|-----------|-----------|-------------------|-------------|
| TB130 | 75LJ012AA | 12 | 49.90 |
| TB131 | 75LJ024AA | 24 | 55.20 |
| TB132 | 75LJ036AA | 36 | 60.00 |
| TB133 | 75LJ048AA | 48 | 64.90 |
| TB134 | 75LJ060AA | 60 | 69.60 |
| TB135 | 75LJ072AA | 72 | 74.30 |

900LI THUMB SWITCH SAFETY AIR GUN

The lightest, thumb lever operated, extended reach, safety air gun available. It is ideal for cleaning and drying machines, ovens, floors and rafters and production equipment. It fits comfortably in the palm of your hand and is constructed of an economical, rugged, die cast aluminum. The Venturi tip has a 1/4" NPT inlet, and a maximum operating pressure 120 PSI, boosts the thrust and limits static pressure to less than 30 PSI when tip is blocked. Meets OSHA standards.

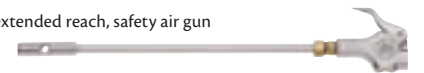

GUARDAIR®

| Model No. | Mfg. No. | Overall Length" | Price /Each |
|-----------|------------|-----------------|-------------|
| TB145 | 900LJ012AA | 12 | 46.90 |
| TB146 | 900LJ024AA | 24 | 47.90 |
| TB147 | 900LJ036AA | 36 | 52.20 |
| TB148 | 900LJ048AA | 48 | 56.10 |
| TB149 | 900LJ060AA | 60 | 59.70 |
| TB150 | 900LJ072AA | 72 | 63.60 |

AIR TOOLS & ACCESSORIES

WHISPER JET® EXTENDED REACH AIR GUNS

- Durable cast aluminum body
- Unique Coandaire® nozzle reduces noise 6 to 20 dB compared to conventional air guns
- Solid conical tip design prevents blockage of nozzle
- Standard stock lengths from 6" - 72"
- 1/4" FNPT inlet
- Meets OSHA standards



GUARDAIR®

| Model No. | Mfg. No. | Description | Price/Each |
|-----------|-----------|---|------------|
| TLZ747 | 80LJ006AA | Whisper Jet® w/ Aluminum Extension & Aluminum Nozzle, 6" | 47.10 |
| TLZ748 | 80LJ012AA | Whisper Jet® w/ Aluminum Extension & Aluminum Nozzle, 12" | 49.10 |
| TLZ749 | 80LJ018AA | Whisper Jet® w/ Aluminum Extension & Aluminum Nozzle, 18" | 51.30 |
| TLZ750 | 80LJ036AA | Whisper Jet® w/ Aluminum Extension & Aluminum Nozzle, 36" | 57.60 |
| TLZ751 | 80LJ048AA | Whisper Jet® w/ Aluminum Extension & Aluminum Nozzle, 48" | 61.80 |

LAZER® SERIES PALM SAFETY AIR GUNS

- All-metal construction with rubber over-molded trigger
- Unique shape and soft over-molded trigger conforms to any hand
- Ergonomic grip reduces hand fatigue
- Ready for use with any 1/4" NPT inlet connector
- Features 1/8" NPSM outlet for optional safety nozzles
- Meets OSHA 1910.242(b) regarding output pressure



GUARDAIR®

| Model No. | Mfg. No. | Description | Price/Each |
|-----------|-------------|---|------------|
| TLZ759 | LZR600 | Palm Switch Style Lazer Air Gun | 24.70 |
| TLZ760 | LZR600006AA | Palm Switch Style Lazer Air Gun w/6" extension | 43.80 |
| TLZ761 | LZR600012AA | Palm Switch Style Lazer Air Gun w/12" extension | 45.20 |
| TLZ762 | LZR600018AA | Palm Switch Style Lazer Air Gun w/18" extension | 46.00 |
| TLZ763 | LZR600024AA | Palm Switch Style Lazer Air Gun w/24" extension | 47.00 |
| TLZ764 | LZR600036AA | Palm Switch Style Lazer Air Gun w/36" extension | 49.20 |
| TLZ765 | LZR600048AA | Palm Switch Style Lazer Air Gun w/48" extension | 51.40 |
| TLZ766 | LZR600060AA | Palm Switch Style Lazer Air Gun w/60" extension | 53.60 |
| TLZ767 | LZR600072AA | Palm Switch Style Lazer Air Gun w/72" extension | 55.80 |

FORCE 5® SERIES AIR GUNS

- Advanced Venturi nozzle delivers 100% of the power
- Air speed increases as it passes through the nozzle, drawing surrounding ambient air through the side ports
- The increased volume of air greatly intensifies power at the tip
- Meets OSHA Standards



GUARDAIR®

| Model No. | Mfg. No. | Description | Price/Each |
|-----------|----------|--|------------|
| TLZ769 | F5024AA | Force 5 Series with 24" Aluminum Extension And Standard Nozzle | 322.00 |
| TLZ770 | F5036AA | Force 5 Series with 36" Aluminum Extension And Standard Nozzle | 329.00 |
| TLZ771 | F5048AA | Force 5 Series with 48" Aluminum Extension And Standard Nozzle | 336.00 |
| TLZ772 | F5060AA | Force 5 Series with 60" Aluminum Extension And Standard Nozzle | 343.00 |

900 THUMB SWITCH SAFETY AIR GUN

The most compact safety air gun available that fits in the palm of your hands. It is constructed of an economical, rugged die cast aluminum. The Venturi tip, consisting of a 1/4" NPT inlet with a maximum operating pressure of 120 PSI, boosts the thrust and limits static pressure to less than 30 PSI. **TB154** includes an air shield to prevent hazardous chip fly-back.



GUARDAIR®

STANDARD MODEL

Model No. TB153
Mfg. No. 900
Price/Each \$21.70

WITH AIR SHIELD

Model No. TB154
Mfg. No. 900S
Price/Each \$27.90

LAZER® SERIES PISTOL GRIP SAFETY AIR GUNS

- All-metal construction
- Unique design offers comfort for any size hand
- Ergonomic grip reduces hand fatigue
- Ready for use with any 1/4" NPT inlet connector
- Features 1/8" NPSM outlet for optional safety nozzles
- Meets OSHA 1910.242(b) regarding output pressure



GUARDAIR®

| Model No. | Mfg. No. | Description | Price/Each |
|-----------|-------------|---|------------|
| TLZ752 | LZR650 | Pistol Grip Style Lazer Air Gun | 24.70 |
| TLZ753 | LZR650006AA | Pistol Grip Style Lazer Air Gun w/6" extension | 43.80 |
| TLZ754 | LZR650012AA | Pistol Grip Style Lazer Air Gun w/12" extension | 45.20 |
| TLZ755 | LZR650018AA | Pistol Grip Style Lazer Air Gun w/18" extension | 46.20 |
| TLZ756 | LZR650024AA | Pistol Grip Style Lazer Air Gun w/24" extension | 47.20 |
| TLZ757 | LZR650036AA | Pistol Grip Style Lazer Air Gun w/36" extension | 49.20 |
| TLZ758 | LZR650048AA | Pistol Grip Style Lazer Air Gun w/48" extension | 51.40 |

EASY ACCESS SAFETY AIR GUNS

- Durable cast aluminum body
- Patented air-shield protective air cone protects operator from dangerous chip fly-back
- Delivers high thrust in hard to reach areas
- 6" screw-on brass extension
- 1/4" FNPT inlet
- Meets OSHA standards



GUARDAIR®

| Model No. | Mfg. No. | Description | Price/Each |
|-----------|----------|------------------------|------------|
| TLZ768 | 765006 | Booster Safety Air Gun | 36.80 |

QUIET FORCE™ NOZZLES

- Made from rugged, lightweight components
- Nozzle is ideal for noise sensitive applications
- Up to 20 dBA quieter than conventional nozzles
- Develops 7 lbs. of thrust using 130 SCFM @100 PSI
- Meets OSHA Standards



GUARDAIR®

| Model No. | Mfg. No. | Description | Price/Each |
|-----------|----------|-----------------------------------|------------|
| TLZ773 | F5024AQF | 24" Force 5 (Quiet Force™ nozzle) | 492.00 |
| TLZ774 | F5036AQF | 36" Force 5 (Quiet Force™ nozzle) | 499.00 |
| TLZ775 | F5048AQF | 48" Force 5 (Quiet Force™ nozzle) | 506.00 |
| TLZ776 | F5060AQF | 60" Force 5 (Quiet Force™ nozzle) | 512.00 |
| TLZ777 | F5072AQF | 72" Force 5 (Quiet Force™ nozzle) | 519.00 |

INFORCER AIR GUNS

- Super Venturi nozzle accelerates air flow
- 3/4" FNPT inlet, adjustable handle
- Thermally insulated ergonomic grip
- Palm or finger actuated dead man safety trigger



GUARDAIR®

SPECIFICATIONS

| Incoming Air Line Pressure (PSI) | Flow (SCFM) | Thrust (lbs.) |
|----------------------------------|-------------|---------------|
| 120 | 185 | 12 |

| Model No. | Mfg. No. | Description | Price/Each |
|-----------|-----------|--|------------|
| TLZ778 | INF5024AA | Inforcer 24" Air Gun with Aluminum Ext and Std Nozzle | 348.00 |
| TLZ779 | INF5036AA | Inforcer 36" Air Gun with Aluminum Ext and Std Nozzle | 355.00 |
| TLZ780 | INF5048AA | Inforcer 48" Air Gun with Aluminum Ext and Std. Nozzle | 361.00 |
| TLZ781 | INF5060AA | Inforcer 60" Air Gun with Aluminum Ext and Std Nozzle | 368.00 |

THE ORIGINAL SAFETY AIR GUNS

- Patented protective air cone protects operator from dangerous chip fly-back
- Venturi nozzle draws in ambient air to intensify both power and thrust
- Knurled adjusting nut controls air volume
- 1/4" FNPT inlet, convenient hanging hook
- Meets OSHA standards



GUARDAIR®

| Model No. | Mfg. No. | Description | Price/Each |
|-----------|----------|---|------------|
| TLZ782 | 57530XB | The Original Safety Air Gun with Volume Control | 38.10 |

AIR TOOLS & ACCESSORIES

COMPACT BLOW GUNS

CHARACTERISTICS

- Flow stabilizer valve for precise air control
- Contoured design to fit comfortably into the user's hand
- Chrome plated, lightweight zinc body
- Cushioned thumb lever
- The hook design enables the gun to be stored conveniently by hanging on almost anything up to 1" diameter
- Industrial and automotive applications
- 1/4" (F) NPT inlet
- Maximum working pressure: 150 PSI

TAPERED TIP BLOW GUNS

- Convenient thumb lever control
- Tapered tip
- Compact design for ease of operation

Applications

- Use in industrial and automotive shops for general cleaning, where high velocity air is not required

Model No. TA820

Mfg. No. 60.112C

Price/Each \$19.50



SAFETY BLOW GUNS W/EXTENSION



| Model No. | Mfg. No. | Description | Price/Each |
|-----------|----------|------------------------|------------|
| TA821 | 60.114 | 3" Straight extension | 35.60 |
| TA822 | 60.116 | 6" Straight extension | 39.30 |
| TA823 | 60.118 | 12" Straight extension | 45.80 |

SIPHON TIP BLOW GUNS

- Complete with 8' of plastic suction tubing and 6" extension
- Convenient thumb lever control
- Chrome plated brass siphon tip



Applications

- Used in industrial and automotive shops for spraying air and liquid mixtures, (i.e. cleaners, solvents and sealants)

Model No. TA825

Mfg. No. 60.130

Price/Each \$53.40

AIR SCREEN TIP BLOW GUNS

- Brass air screen tip producing 30° conical safety air screen designed to deflect particles away from operator
- Minimizes blow-back of chips or particles

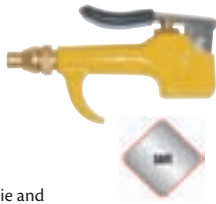

Applications

- Used in machine, tool and die and where drilled or tapped blind holes must be blown out causing chip and particle blow-back

Model No. TA817

Mfg. No. 60.102

Price/Each \$33.90

RUBBER TIP BLOW GUNS

- Will not scratch or mark surfaces
- Provides a leak proof seal between gun and fluid lines



Applications

- Used in automotive and industrial shops for blowing out blocked passages such as automatic transmissions, carburetors, moulds and dies

Model No. TA819

Mfg. No. 60.110C

Price/Each \$19.90

INTERCHANGEABLE TIP BLOW GUN KITS

- Designed for light duty applications
- Contoured design fits comfortably in operator's hand
- Cushioned thumb lever
- Large hanging hook
- Lightweight zinc body
- Brass valve with only one moving part
- 1/4" Female NPT
- Chrome plated
- Comes with four tips: safety tip, rubber tip, needle tip, and long needle tip



Long Needle

Needle

Safety Tip

Rubber Tip

Model No. BV804

Mfg. No. 60.070C

Price/Each \$20.10

TOPRING

COMPACT PERMATIP SAFETY BLOW GUNS

- Tamper-proof vent holes increase total air flow
- In the event of tip blockage, air escapes through radial holes, keeping tip pressure safely below 30 PSI
- Case-hardened steel restrictor inside the gun provides a concentrated air stream

| Model No. | Mfg. No. | Noise Level* dB | Air Consumption* SCFM | Price/Each |
|-----------|----------|-----------------|-----------------------|------------|
| TA816 | 60.100C | 89 | 2.5 | 18.90 |

*At 75 PSI air line pressure



TOPRING

AIR BLOW GUNS WITH BRASS SAFETY NOZZLE

- Contoured design fits comfortably in operators hand
- Brass tip increases air flow
- Cushioned thumb lever
- Hook design allows for easy and convenient storage
- 1/4" (F) - 18 NPT inlet

Model No. TLV118

Price/Each \$12.50



aurora tools®

5-PC. BLOW GUN KITS

- Contoured design fits comfortably in operators hand
- Chrome plated
- Large hanging hook
- 1/4" (F) - 18 NPT
- Comes with four tips: Safety tip, rubber tip, needle tip, and long needle tip

Model No. TLZ147

Price/Each \$11.50



aurora tools®

TWO-PIECE STAINLESS STEEL BALL VALVES - SERIES BV2M

FULL PORT, 1000 PSI (69 BAR)

End Connections: Female NPT
Pressure Limits: 1000 PSI (69 bar) WOG, 150 PSI (10.3 bar) SWP
Wetted Materials: Body, ball, end cap: CF8M SS; stem: 316 SS; seat, thrust washer: RTFE; end gasket, stem packing: PTFE
Temperature Limits: -20 to 450°F (-29 to 232°C)

| Model No. | Mfg. No. | Size" | Price/Each |
|-----------|----------|-------|------------|
| THZ590 | BV2M100 | 1/4 | 51.00 |
| THZ591 | BV2M101 | 3/8 | 46.00 |
| THZ592 | BV2M102 | 1/2 | 57.00 |
| THZ593 | BV2M103 | 3/4 | 73.00 |
| THZ594 | BV2M104 | 1 | 123.00 |
| THZ595 | BV2M105 | 1 1/4 | 139.00 |
| THZ596 | BV2M106 | 1 1/2 | 191.00 |
| THZ597 | BV2M107 | 2 | 276.00 |
| THZ598 | BV2M108 | 2 1/2 | 557.00 |
| THZ599 | BV2M109 | 3 | 720.00 |



THZ590

MINI BRASS BALL VALVES

Service: Gases and liquids compatible with wetted materials. Not rated for steam use.

Wetted Materials: Valve body: chrome plated brass
 Valve ball: chrome-plated brass
 O-ring stem seal: Fluoroelastomer
 Ball seats: PTFE

Temperature Limits: MV4: -4 to 200°F (-20 to 93.3°C)
 MV5: -4 to 250°F (-20 to 121°C)

Connections: NPT, see model chart



Lever

Tee

Wedge

Screwdriver

FEMALE X FEMALE

MALE X FEMALE

| Pipe Size" | Cv Value | Model No. | Mfg. No. | Price /Each | Model No. | Mfg. No. | Price /Each |
|--|----------|-----------|----------|-------------|-----------|----------|-------------|
| LEVER HANDLE - 200 PSI (CWP) MAXIMUM PRESSURE | | | | | | | |
| 1/8 | 5.3 | THZ638 | MVB-LF1 | 9.00 | THZ654 | MVB-LM1 | 10.00 |
| 1/4 | 6.6 | THZ639 | MVB-LF2 | 9.00 | THZ655 | MVB-LM2 | 10.00 |
| 3/8 | 6.6 | THZ640 | MVB-LF3 | 9.00 | THZ656 | MVB-LM3 | 10.00 |
| 1/2 | 11 | THZ641 | MVB-LF4 | 12.00 | THZ657 | MVB-LM4 | 12.00 |
| TEE HANDLE - 200 PSI (CWP) MAXIMUM PRESSURE | | | | | | | |
| 1/8 | 5.3 | THZ642 | MVB-TF1 | 10.00 | THZ658 | MVB-TM1 | 10.00 |
| 1/4 | 6.6 | THZ643 | MVB-TF2 | 10.00 | THZ659 | MVB-TM2 | 10.00 |
| 3/8 | 6.6 | THZ644 | MVB-TF3 | 10.00 | THZ660 | MVB-TM3 | 10.00 |
| 1/2 | 11 | THZ645 | MVB-TF4 | 12.00 | THZ661 | MVB-TM4 | 12.00 |
| WEDGE HANDLE - 450 PSI (CWP) MAXIMUM PRESSURE | | | | | | | |
| 1/8 | 5.3 | THZ646 | MVB-WF1 | 10.00 | THZ662 | MVB-WM1 | 10.00 |
| 1/4 | 6.6 | THZ647 | MVB-WF2 | 10.00 | THZ663 | MVB-WM2 | 10.00 |
| 3/8 | 6.6 | THZ648 | MVB-WF3 | 10.00 | THZ664 | MVB-WM3 | 10.00 |
| 1/2 | 11 | THZ649 | MVB-WF4 | 12.00 | THZ665 | MVB-WM4 | 12.00 |
| SCREWDRIVER SLOT - 450 PSI (CWP) MAXIMUM PRESSURE | | | | | | | |
| 1/8 | 5.3 | THZ650 | MV5-SF1 | 18.00 | THZ666 | MV5-SM1 | 18.00 |
| 1/4 | 6.6 | THZ651 | MV5-SF2 | 17.00 | THZ667 | MV5-SM2 | 17.00 |
| 3/8 | 6.6 | THZ652 | MV5-SF3 | 17.00 | THZ668 | MV5-SM3 | 17.00 |
| 1/2 | 11 | THZ653 | MV5-SF4 | 23.00 | THZ669 | MV5-SM4 | 23.00 |

THREE-PIECE BALL VALVES - SERIES WE02

INVESTMENT CAST STAINLESS STEEL CONSTRUCTION, INTEGRAL ACTUATOR MOUNTING PAD

End Connections: Female NPT
Pressure Limits: 1000 PSI (68.9 bar) WOG; 150 PSI (10.3 bar) SWP
Wetted Materials: Body, ball, end cap: CF8M SS; stem: 316 SS; seat, thrust washer: RTFE; stem packing: PTFE
Temperature Limits: -20 to 392°F (-29 to 200°C)

| Model No. | Mfg. No. | Size" | Price/Each |
|-----------|------------|-------|------------|
| THZ602 | WE02-CHD00 | 1/2 | 96.00 |
| THZ603 | WE02-DHD00 | 3/4 | 115.00 |
| THZ605 | WE02-FHD00 | 1 1/4 | 240.00 |
| THZ606 | WE02-GHD00 | 1 1/2 | 364.00 |
| THZ607 | WE02-HHD00 | 2 | 479.00 |
| THZ608 | WE02-IHD00 | 2 1/2 | P.O.A. |
| THZ609 | WE02-JHD00 | 3 | P.O.A. |



THZ602

TWO-PIECE HAND LEVER BRASS BALL VALVES - SERIES BV2MB

FULL PORT, ECONOMICAL, BLOWOUT-PROOF STEM

Body: Two-Piece
End Connections: 1/4" to 3" female NPT
Pressure Limits: 1/4" to 1": 600 PSI (41.4 bar), 1 1/4" to 2": 400 PSI (27.6 bar), 2 1/2 to 3": 200 PSI (13.8 bar) WOG
Wetted Materials: Body and body cap: forged brass (ASTM B283-C37700); ball and stem: brass; seat and packing Teflon®
Temperature Limits: 10 to 200°F (-12 to 93°C)
Other Materials: Body seal: rubber; handle: plated steel; nut and gasket: brass



THZ610

| Model No. | Mfg. No. | Size" | Cv | Price/Each |
|-----------|----------|-------|-----|------------|
| THZ610 | BV2MB00 | 1/4 | 7.5 | 8.00 |
| THZ611 | BV2MB01 | 3/8 | 7.5 | 8.00 |
| THZ612 | BV2MB02 | 1/2 | 16 | 12.00 |
| THZ613 | BV2MB03 | 3/4 | 43 | 18.00 |
| THZ614 | BV2MB04 | 1 | 58 | 27.00 |
| THZ615 | BV2MB05 | 1 1/4 | 105 | 42.00 |
| THZ616 | BV2MB06 | 1 1/2 | 160 | 59.00 |
| THZ617 | BV2MB07 | 2 | 325 | 87.00 |
| THZ618 | BV2MB08 | 2 1/2 | 475 | 238.00 |
| THZ619 | BV2MB09 | 3 | 780 | 324.00 |

BUTTERFLY VALVES - SERIES BFV

LOW COST, LEVER OPERATED, LUG OR WAFER PATTERN, 225 PSI

Service: Compatible liquids, gases, and steam
Line Size: 2" to 12"
Body Style: 2-way, wafer or lug butterfly
End Connections: Flange, to be used with flanges that are ANSI Class 125 (B16.1) and ANSI Class 150 (B16.5) dimensions
Pressure Limits: 225 PSI (151.5 bar) WOG
Wetted Materials: Body: Ductile iron
 Disc: 316 SS
 Seat and O-ring: EPDM or PTFE
 Stem: 410 SS
Temperature Limits: EPDM: -50 to 250°F (-46 to 121°C).
 PTFE: 0 to 300°F (-18 to 149°C)
Bearings: Nylontron
Flow Rate: See Cv chart
Operator: 2 to 6": 10-position locking hand lever. 8 to 12": manual gear



Wafer



Lug



CV VALUES

| Size | Degree Opening | | | | | | | | | Full Open |
|-------|----------------|-----|-----|------|------|------|------|------|------|-----------|
| | 10° | 20° | 30° | 40° | 50° | 60° | 70° | 80° | 90° | |
| 2 | 0.1 | 5 | 12 | 24 | 45 | 64 | 90 | 125 | 135 | |
| 2 1/2 | 0.2 | 8 | 20 | 37 | 65 | 98 | 144 | 204 | 220 | |
| 3 | 0.3 | 12 | 22 | 39 | 70 | 116 | 183 | 275 | 302 | |
| 4 | 0.5 | 17 | 36 | 78 | 139 | 230 | 364 | 546 | 600 | |
| 5 | 0.8 | 29 | 61 | 133 | 237 | 392 | 620 | 930 | 1022 | |
| 6 | 2 | 45 | 95 | 205 | 366 | 605 | 958 | 1437 | 1579 | |
| 8 | 3 | 89 | 188 | 408 | 727 | 1202 | 1903 | 2854 | 3136 | |
| 10 | 4 | 151 | 320 | 694 | 1237 | 2047 | 3240 | 4859 | 5340 | |
| 12 | 5 | 234 | 495 | 1072 | 1911 | 3162 | 5005 | 7505 | 8250 | |

| Model No. | Mfg. No. | Size" | Type | Liner | Price /Each |
|-----------|-----------------|-------|-------|-------|-------------|
| THZ620 | BFV202WFB311HLO | 2 | Wafer | EPDM | 137.00 |
| THZ621 | BFV202WFB341HLO | 2 | Wafer | PTFE | 188.00 |
| THZ622 | BFV202LTB311HLO | 2 | Lug | EPDM | 166.00 |
| THZ623 | BFV202LTB341HLO | 2 | Lug | PTFE | 203.00 |
| THZ624 | BFV225WFB311HLO | 2 1/2 | Wafer | EPDM | 156.00 |
| THZ625 | BFV225WFB341HLO | 2 1/2 | Wafer | PTFE | 238.00 |
| THZ626 | BFV225LTB311HLO | 2 1/2 | Lug | EPDM | 203.00 |
| THZ627 | BFV225LTB341HLO | 2 1/2 | Lug | PTFE | 257.00 |
| THZ628 | BFV203WFB311HLO | 3 | Wafer | EPDM | 188.00 |
| THZ629 | BFV203WFB341HLO | 3 | Wafer | PTFE | 284.00 |
| THZ630 | BFV203LTB311HLO | 3 | Lug | EPDM | 196.00 |
| THZ631 | BFV203LTB341HLO | 3 | Lug | PTFE | 301.00 |
| THZ632 | BFV204WFB311HLO | 4 | Wafer | EPDM | 267.00 |
| THZ633 | BFV204WFB341HLO | 4 | Wafer | PTFE | 381.00 |
| THZ634 | BFV204LTB311HLO | 4 | Lug | EPDM | 284.00 |
| THZ635 | BFV204LTB341HLO | 4 | Lug | PTFE | 423.00 |
| THZ636 | BFV205WFB311HLO | 5 | Wafer | EPDM | 355.00 |
| THZ637 | BFV205WFB341HLO | 5 | Wafer | PTFE | 490.00 |

AIR TOOLS & ACCESSORIES

IN-LINE AIR FLOW REGULATORS

- Especially designed to control air pressure to air tools
- High volume air adjusting regulator
- Pressure Range 0-160 PSI



| Model No. | Mfg. No. | Inlet NPT(M)" | Outlet NPT(F)" | Price /Each |
|-----------|----------|---------------|----------------|-------------|
| TA838 | 62.105 | 1/4 | 1/4 | 26.20 |

TOPRING



AIR ADJUSTING VALVES

- Permits accurate flow control in either direction
- Set knurled knob to desired flow rate
- Spring-loaded ratchet permit positive flow adjustment without drift
- Oil resistant seals prevent leakage

Warning: Do not use as a shut-off-valve

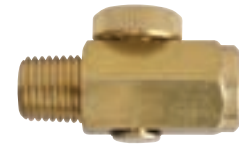

TOPRING

| Model No. | Mfg. No. | Inlet (F) NPT" | Outlet (M) NPT" | Price /Each |
|-----------|----------|----------------|-----------------|-------------|
| TA837 | 62.101 | 1/4 | 1/4 | 9.97 |

IN-LINE PRE-SET PRESSURE REGULATORS

- Ensure optimal air tool efficiency by supplying a constant pre-set pressure
- Limit over-consumption of compressed air, thereby reducing energy costs
- Blow guns in order to respect OSHA and other Safety Agencies' requirements (maximum pressure of 30 PSI)

| Model No. | Mfg No. | Pre-Set Pressure | Price/Each |
|-----------|---------|------------------|------------|
| TLZ013 | 62.202C | 27 | 56.80 |
| TLZ014 | 62.210C | 90 | 56.80 |

TOPRING



MINI REGULATORS

- Specially designed for use with air tools for accurate pressure regulation
- Full diaphragm regulation for precise air pressure
- 3-position knob pushed to lock and can be removed for taper - resistance
- Push-pull lock setting to avoid unplanned readjustment
- Lightweight and compact
- Temp. Range: 40°F to 120°F
- Flow Cap.: Up to 14 SCFM
- Pressure PSI 2-125 PSI



TOPRING



| Model No. | Mfg. No. | Port Size (M) NPT" | Pressure PSI | Price /Each |
|-----------|----------|--------------------|--------------|-------------|
| TA849 | 62.125C | 1/4 | 0-165 | 65.40 |
| TA796 | 55.121 | Replacement Gauge | | 11.60 |

ANTI HOSE WHIP SAFETY VALVES

- Anti hose whip safety valve is an inline emergency shutoff valve
- Under failure conditions, the valve closes - the air is shut off
- Small amount of air continues to bleed after shut off at a rate of 9 SCFM.
- Automatically return to the normal position when pressure is re-established

OSHA standard no. 1926.302(b)(7): "All hoses exceeding 1/2" inside diameter shall have a safety device at the source of supply or branch line to reduce pressure in case of hose failure." Topring anti hose whip safety valves satisfy this standard.

| Model No. | Mfg. No. | Inlet Size NPT | Outlet (F) NPT | Shutoff Range* (SCFM) | Total Length" | Price /Each |
|-----------|----------|----------------|----------------|-----------------------|---------------|-------------|
| BB396 | 58.952 | 1/4 (M) | 1/4 | 21 | 2 21/64 | 59.70 |
| BB398 | 58.957 | 3/8 (M) | 3/8 | 42 | 2 3/4 | 78.00 |
| UQ888 | 58.962 | 1/2 (M) | 1/2 | 99 | 3 7/64 | 89.30 |
| UQ889 | 58.967 | 3/4 (F) | 3/4 | 125 | 2 63/64 | 157.00 |

* Based on an inlet pressure of 90 PSI

TOPRING



PRESSURE GAUGES

- Corrosion resistant stainless steel case and ring, plastic lens
- Balanced adjustable black pointer
- Soft soldered phosphor bronze tube with brass socket. Suitable for steam, water, air, oil, gas or any medium not corrosive to copper alloys
- Phosphor bronze movement is recommended for average general use
- Easy to read dial, white background with bold black numerals and graduations, 270° arc
- 1/4" NPT bottom connection only
- 1% accuracy

REED



| Model No. | Mfg. No. | Dial Ranges | Figure Intervals | Minor Div. | Price /Each |
|------------------------|---------------|--------------|------------------|------------|-------------|
| PRESSURE RANGES | | | | | |
| IA326 | 421AVND-30 | 0-30 PSI | 5 PSI | 0.5 PSI | 44.00 |
| IA327 | 421AVND-60 | 0-60 PSI | 10 PSI | 1 PSI | 44.00 |
| IA328 | 421AVND-100 | 0-100 PSI | 10 PSI | 1 PSI | 44.00 |
| IA329 | 421AVND-160 | 0-160 PSI | 20 PSI | 2 PSI | 44.00 |
| IA330 | 421AVND-200 | 0-200 PSI | 20 PSI | 2 PSI | 44.00 |
| IA331 | 421AVND-300 | 0-300 PSI | 50 PSI | 5 PSI | 44.00 |
| IA332 | 421AVND-500 | 0-500 PSI | 50 PSI | 5 PSI | 44.00 |
| VACUUM RANGES | | | | | |
| IA333 | 421AVND-30VAC | 30"-0 Hg Vac | 5" | 0.5" | 44.00 |

INADEQUATE PIPING & HOSES INFORMATION

The largest pressure loss in a system serving air tools is found in two areas: hoses that are too long and hoses that are too small. The longer the hose, the more friction is created, regardless of size; this can be addressed by increasing hose size. For this reason, small diameter hoses inevitably limit flow. Choosing the proper diameter hose for the distance and flow required will go a long way to limiting pressure loss at the tool.

RECOMMENDED FLEXIBLE HOSE SIZES (I.D.) FOR VARIOUS DISTANCES & FLOWS

| Flow (SCFM) | Pressure PSI | Distance | | | | | | | |
|-------------|--------------|----------|------|-----|-----|------|------|------|-----|
| | | 25' | 35' | 50' | 75' | 100' | 150' | 200' | |
| 1 | 100 | 1/4 | 1/4 | 1/4 | 1/4 | 1/4 | 1/4 | 1/4 | 1/4 |
| 2 | 100 | 1/4 | 1/4 | 1/4 | 1/4 | 1/4 | 1/4 | 1/4 | 1/4 |
| 5 | 100 | 1/4 | 1/4 | 1/4 | 1/4 | 5/16 | 5/16 | 3/8 | 3/8 |
| 10 | 100 | 5/16 | 5/16 | 3/8 | 3/8 | 3/8 | 1/2 | 1/2 | 1/2 |
| 15 | 100 | 3/8 | 3/8 | 1/2 | 1/2 | 1/2 | 1/2 | 1/2 | 1/2 |
| 20 | 100 | 3/8 | 1/2 | 1/2 | 1/2 | 1/2 | 3/4 | 3/4 | 3/4 |
| 25 | 100 | 1/2 | 1/2 | 1/2 | 1/2 | 3/4 | 3/4 | 3/4 | 3/4 |
| 30 | 100 | 1/2 | 1/2 | 1/2 | 3/4 | 3/4 | 3/4 | 3/4 | 3/4 |
| 40 | 100 | 1/2 | 3/4 | 3/4 | 3/4 | 3/4 | 3/4 | 3/4 | 3/4 |
| 50 | 100 | 3/4 | 3/4 | 3/4 | 3/4 | 3/4 | 3/4 | 1 | 1 |
| 60 | 100 | 3/4 | 3/4 | 3/4 | 3/4 | 3/4 | 1 | 1 | 1 |
| 70 | 100 | 3/4 | 3/4 | 3/4 | 3/4 | 1 | 1 | 1 | 1 |
| 80 | 100 | 3/4 | 3/4 | 3/4 | 1 | 1 | 1 | 1 | 1 |
| 90 | 100 | 3/4 | 3/4 | 1 | 1 | 1 | 1 | 1 | 1 |
| 100 | 100 | 3/4 | 3/4 | 1 | 1 | 1 | 1 | 1 | 1 |

Calculations based on a pressure loss (ΔP) of maximum 5 PSIG

NYLON COIL AIR HOSES W/FITTINGS

- Light and easy to handle
- Maximum working pressure, 300 PSI
- 3/8" NPT Male threads
- High impact and abrasion resistance
- Excellent elastic memory, can be stretched repeatedly yet return to original shape for convenient storage
- Colour: High-viz yellow



aurora tools

| Model No. | NPT (M)" | Length' | Price/Each |
|-----------|----------|---------|------------|
| TLZ150 | 1/4 | 25 | 12.30 |
| TLZ151 | 1/4 | 50 | 19.55 |
| TLZ152 | 3/8 | 25 | 21.90 |
| TLZ153 | 3/8 | 50 | 32.65 |

AIR HOSE REPAIR KITS

- For a 3/8" hose, 1/4" NPT threads
- Set includes:**
- 1 hose splicer
 - 1 hose end fitting
 - 3 hose clamps
- Model No. TLZ149**
Price/Each \$6.45



PLUG QUICK COUPLER KITS, 5 PIECES

- Set includes:**
- One 1/4" quick coupler
 - One 1/4" female plug
 - Three 1/4" male plugs
- Model No. TLZ148**
Price/Each \$16.50



aurora tools

See page 1374
for Tubing Cutters



VOLUME/CAPACITY

| | |
|---|---|
| 1 in ³ (cubic inch) = 16.387 cm ³ | 1 m ³ = 35.3 ft ³ |
| 1 ft ³ (cubic feet) = 0.0283 m ³ | 1 litre = 0.001 m ³ |
| 1 ft ³ = 28.32 litres | 1 litre = 0.0353 ft ³ |
| 1 gallon (US) = 3.785 litres | 1 litre = 0.264 gallon (US) |
| 1 gallon (imperial) = 4.546 litres | 1 litre = 0.220 gallon (imperial) |
| 1 cm ³ (cubic centimeter) = 0.0610 in ³ | 1 fl. ounce (imperial) = 28.413 ml |
| 1 m ³ (cubic meter) = 1000 litres | 1 litre = 35.2 ounces |

LENGTH

| | |
|-----------------------|-----------------|
| 1 inch = 25.4 mm | 1 mm = 0.039 in |
| 1 ft (feet) = 0.305 m | 1 m = 3.28 ft |

WEIGHT

| | |
|---------------------|-------------------|
| 1 ounce = 28.349 g | 1 g = 0.035 ounce |
| 1 pound = 453.592 g | 1 kg = 2.205 lbs |

HOSES & HOSE CLAMPS

EASYFLEX AIR HOSES W/FITTINGS

- Techno polymer engineered to be tough and ultra-flexible at extremely low temperatures
- Easily re-coiled after use, no memory
- Lightweight
- -65°F to 149°F, 300 PSI
- Colour: Yellow or blue

TLZ735



TOPRING

| Model No. | Mfg. No. | Colour | Hose I.D." | Hose Length' | Fittings (M)NPT | Price /Each |
|-----------|----------|--------|------------|--------------|-----------------|-------------|
| TLZ735 | 72.164 | Yellow | 1/4 | 25 | 1/4 | 35.90 |
| TLZ736 | 72.168 | Yellow | 1/4 | 50 | 1/4 | 61.40 |
| TLZ737 | 72.170 | Yellow | 1/4 | 100 | 1/4 | 108.00 |
| TLZ738 | 72.364 | Yellow | 3/8 | 25 | 1/4 | 38.20 |
| TNB049 | 72.384 | Blue | 3/8 | 25 | 1/4 | 38.50 |
| TLZ739 | 72.368 | Yellow | 3/8 | 50 | 1/4 | 72.10 |
| TLZ740 | 72.388 | Blue | 3/8 | 50 | 1/4 | 132.00 |

NYLON AIR HOSES W/FITTINGS

- Self-storing
- Excellent abrasion resistance
- Swivel fittings allow maximum directional flexibility
- Reusable and repairable fittings
- -40°F to 180°F, up to 200 PSI
- Colour: Red

TA181

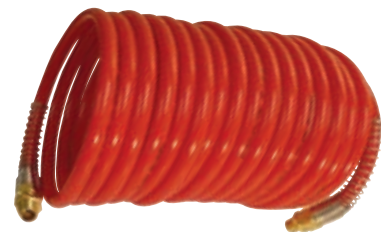

TOPRING

| Model No. | Mfg. No. | Hose I.D." | Hose Length' | Fittings (M)NPT | Price /Each |
|-----------|----------|------------|--------------|-----------------|-------------|
| TA181 | 11.421 | 1/4 | 12,5 | 1/4 | 28.10 |
| TA182 | 11.441 | 1/4 | 25 | 1/4 | 37.20 |
| TA185 | 11.641 | 3/8 | 25 | 3/8 | 67.30 |
| TA187 | 11.681 | 3/8 | 50 | 3/8 | 99.40 |

REPLACEMENT SWIVEL FITTINGS

| Model No. | Mfg. No. | Hose I.D." | Hose Length' | Fittings (M)NPT | Price /Each |
|-----------|----------|------------|--------------|-----------------|-------------|
| TS332 | 11.042 | 1/4 | - | 1/4 | 11.90 |
| TS334 | 11.062 | 3/8 | - | 3/8 | 20.80 |
| TS335 | 11.065 | 3/8 | - | 1/4 | 16.40 |

FLEXHYBRID HOSES W/FITTINGS

- Engineered hybrid polymer combining best features from PVC and rubber
- Superior flexibility, lightweight and economical
- 14°F to 140°F, 300 PSI
- Colour: Red

TNB036



TOPRING

| Model No. | Mfg. No. | Hose I.D." | Hose Length' | Fittings (M)NPT | Price /Each |
|-----------|----------|------------|--------------|-----------------|-------------|
| TNB036 | 70.115 | 1/4 | 25 | 1/4 | 22.10 |
| TNB037 | 70.119 | 1/4 | 50 | 1/4 | 39.60 |
| BC368 | 70.316 | 3/8 | 25 | 1/4 | 26.20 |
| BC370 | 70.318 | 3/8 | 50 | 1/4 | 46.40 |
| BC376 | 70.415 | 1/2 | 25 | 3/8 | 49.90 |
| BC380 | 70.419 | 1/2 | 50 | 3/8 | 87.80 |

AIRFLEX RUBBER AIR HOSES W/FITTINGS

- Excellent abrasion resistance
- Medium oil resistance
- -40°F to 212°F, 250 PSI
- Colour: Red

BU260



TOPRING

| Model No. | Mfg. No. | Hose I.D." | Hose Length' | Fittings (M)NPT | Price /Each |
|-----------|----------|------------|--------------|-----------------|-------------|
| BU260 | 71.114 | 1/4 | 25 | 1/4 | 35.70 |
| UP477 | 71.118 | 1/4 | 50 | 1/4 | 61.20 |
| BU282 | 71.315 | 3/8 | 25 | 1/4 | 43.60 |
| BU286 | 71.319 | 3/8 | 50 | 1/4 | 76.80 |
| BU285 | 71.318 | 3/8 | 50 | 3/8 | 77.20 |
| BU306 | 71.419 | 1/2 | 50 | 3/8 | 109.00 |
| BU305 | 71.418 | 1/2 | 50 | 1/2 | 111.00 |

TOPFLEX RUBBER AIR HOSES

- Maximum oil resistance
- Spark resistant
- Reusable fittings – no crimping required
- -40°F to 212°F, 250 PSI
- Colour: Black



TA511

TNB038



TOPRING

| Model No. | Mfg. No. | Hose I.D." | Hose Length' | Fittings (M)NPT | Price /Each |
|-----------|----------|------------|--------------|-----------------|-------------|
| TNB038 | 77.125 | 1/4 | 25 | 1/4 | 50.20 |
| TNB039 | 77.128 | 1/4 | 50 | 1/4 | 96.10 |
| TNB040 | 77.130 | 1/4 | 100 | 1/4 | 187.00 |
| BU472 | 77.348 | 3/8 | 50 | 1/4 | 138.00 |
| TNB042 | 77.338 | 3/8 | 50 | 3/8 | 129.00 |
| TNB043 | 77.110 | 1/4 | 600 | - | 982.00 |
| TNB044 | 77.310 | 3/8 | 600 | - | 1309.00 |

REPLACEMENT REUSABLE FITTINGS

| Model No. | Mfg. No. | Hose I.D." | Hose Length' | Fittings (M)NPT | Price /Each |
|-----------|----------|------------|--------------|-----------------|-------------|
| TA511 | 41.861 | 1/4 | - | 1/4 | 2.66 |
| TA512 | 41.862 | 3/8 | - | 1/4 | 2.78 |
| TA526 | 41.880 | 1/4 | - | Barb joint | 2.35 |
| TA527 | 41.881 | 3/8 | - | Barb joint | 3.75 |

FLEXCOIL POLYURETHANE AIR HOSES W/FITTINGS

- Self-storing
- Offers little resistance to pull and automatically recoils
- Swivel fittings allow maximum directional flexibility
- Reusable and repairable fittings
- -40°F to 158°F, 140 PSI
- Colour: Red

TA216

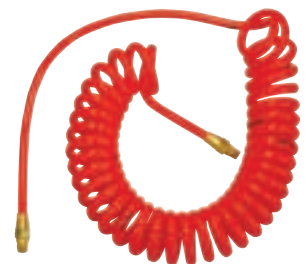

TOPRING

| Model No. | Mfg. No. | Hose I.D." | Hose Length' | Fittings (M)NPT | Price /Each |
|-----------|----------|------------|--------------|-----------------|-------------|
| TA216 | 17.610 | 1/4 | 15 | 1/4 | 37.10 |
| TA217 | 17.615 | 1/4 | 20 | 1/4 | 46.30 |
| TA218 | 17.620 | 1/4 | 25 | 1/4 | 51.10 |
| TA219 | 17.625 | 1/4 | 30 | 1/4 | 74.10 |
| TA220 | 17.650 | 1/4 | 50 | 1/4 | 87.10 |
| TA221 | 17.660 | 5/16 | 15 | 1/4 | 69.60 |
| TA223 | 17.670 | 5/16 | 25 | 1/4 | 99.60 |
| TA226 | 17.710 | 3/8 | 15 | 3/8 | 81.70 |
| TA227 | 17.714 | 3/8 | 15 | 1/4 | 82.40 |
| TA230 | 17.720 | 3/8 | 25 | 3/8 | 109.00 |
| TA231 | 17.724 | 3/8 | 25 | 1/4 | 109.00 |

CUT TO LENGTH TUBING



GENERAL PURPOSE FOR COMPRESSED AIR

Characteristics:

- Ideal for compressed air and water service
- Moderate resistance to oil
- Resists heat, sunlight, ozone and weather

Applications:

- Air tools

Specifications:

- Working temperature: 40°F to 200°F (40°C to 93°C)

Construction:

Tube: Black EPDM
 Cover: Red EPDM
 Reinforcement: Synthetic rubber - multiple textile plies

| Model No. | Hose I.D." | Max. PSI | Price /Each Ft. |
|-----------|------------|----------|-----------------|
| TA070 | 1/4 | 250 | 1.32 |
| TA071 | 5/16 | 300 | 1.51 |
| TA072 | 3/8 | 250 | 1.65 |
| TA073 | 1/2 | 250 | 2.16 |
| TZ899 | 3/4 | 250 | 3.23 |



MULTI-PURPOSE MEDIUM OIL RESISTANT (NON-CONDUCTIVE) TUBING

Characteristics:

- Double-reinforced makes it extra strong and tough
- Durable for rugged environmental conditions
- Economical and versatile general purpose hose (air and water)
- Lightweight, flexible
- Performs well in both hot and cold temperatures
- Long service life
- Available in lengths up 700' in one piece

Applications:

- Ideal for air tool and compressed air applications
- Used with all kinds of compressed air equipment found in foundries, shipyards, engineering workshops, construction sites, quarries and mines.

Specifications:

- Working temperature: -29°C to +82°C (-20°F to +180°F)
- Working pressure: 250 PSI two braids

Construction:

Tube: Black nitrile tube, Class A
 Cover: Red medium oil resistant nitrile blend, Class B
 Reinforcement: Spirals of synthetic yarn

| Model No. | Hose I.D." | Hose O.D." | Wt. lbs. per 100' | Price /Each ft. |
|-----------|------------|------------|-------------------|-----------------|
| TA074 | 1/4 | 0.5 | 8 | 1.72 |
| TA075 | 3/8 | 0.72 | 17 | 1.99 |
| TA076 | 1/2 | 0.88 | 24 | 2.45 |

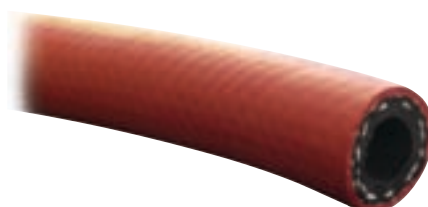

MULTI-PURPOSE FOR COMPRESSED AIR & FLUIDS

Characteristics:

- High quality multi-purpose hose
- Durable for longer life
- High flexibility
- Abrasion resistance
- Good resistance to oils and greases, gasoline and solvents
- May be used to transmit water, oil and many chemicals up to 300 PSI

Applications:

- Ideal for air tool applications

Specifications:

- Working temperature: -20°F to 250°F (-29°C to 121°C)
- Working pressure: 300 PSI two braids

Construction:

Tube: Black Buna-N
 Cover: Red neoprene
 Reinforcement: Synthetic fibre braids

| Model No. | Hose I.D." | Hose O.D." | Wt. lbs. per 100' | Price /Each Ft. |
|-----------|------------|------------|-------------------|-----------------|
| TA081 | 1/4 | 0.63 | 18 | 2.22 |
| TA082 | 3/8 | 0.72 | 20 | 2.41 |
| TA083 | 1/2 | 0.88 | 27 | 3.14 |
| TZ901 | 3/4 | 1.14 | 43 | 4.42 |
| TA084 | 1 | 1.50 | 65 | 6.54 |

AUTOMATIC REWIND HOSE REELS W/PVC AIR HOSE

- Durable construction, made from high impact resistant polypropylene
- Compact design
- Double adjustment action to lock hose at desired length
- Sealed connection points at swivel and hose inlet to prevent leaks
- Integrated wall/overhead swivel bracket
- Non-sag hose rollers reduce hose wear
- Adjustable hose stopper
- 60" lead-in hose included



TLV341

TOPRING

| Model No. | Mfg. No. | Hose Width" | Hose Length' | Inlet (M) NPT" | Outlet (M) NPT" | Price /Each |
|-----------|----------|-------------|--------------|----------------|-----------------|-------------|
| TLV341 | 79.370 | 1/4 | 33 | 1/4 | 1/4 | 165.00 |
| TLV342 | 79.375 | 3/8 | 30 | 1/4 | 1/4 | 190.00 |
| TLV343 | 79.380 | 3/8 | 50 | 1/4 | 1/4 | 197.00 |

MANUAL REWIND AIR/WATER REELS

- This light weight hand crank reel is designed for general use and lighter-duty applications that require longer lengths of low pressure air/water hoses
- Economical choice for storing and retrieving hoses
- Brass swivel and brass inlet
- Maximum temperature 150°F (65°C)
- Hose not included and assembly is required



REELCRAFT

| Model No | Hose I.D." | Outlet (F)NPT" | Inlet (F)NPT" | Hose Length' | Max PSI | Dimensions W" x D" x H" | Wt lbs. | Price /Each |
|----------|------------|----------------|---------------|--------------|---------|--------------------------|---------|-------------|
| FI054 | 3/8 | 3/8 | 3/8 | 50 | 300 | 16 3/4 x 10 1/2 x 11 1/2 | 12 | 119.00 |
| FI055 | 3/8 | 3/8 | 3/8 | 100 | 300 | 21 1/8 x 10 1/2 x 11 1/2 | 16 | 149.00 |

HOSES & HOSE CLAMPS



WELDING HOSE REELS

- Heavy-duty, reinforced steel stampings for increased strength
- 1/4" oxygen and acetylene twin hose
- Leakproof double O-ring seals
- Compact design allows reels to fit in tight locations
- Multi-position guide arms for multiple mounting options
- Kinkless, oil resistant high quality hose
- Spring rewind features long life spring with declutching arbor
- Grade R hose
- Durable, corrosion-resistant powder coat paint

aurora tools®



TLZ487

| Model No. | Drive Type | Hose I.D." | Hose Length' | Max PSI | Oxygen Inlet & Outlet | Acetylene Inlet & Outlet | Dimensions | | | | Wt. lbs. | Price /Each | |
|-----------|------------|------------|--------------|---------|-------------------------|--------------------------|------------|---|--------|---|----------|-------------|--------|
| | | | | | | | W" | x | D" | x | H" | | |
| TLZ487 | Spring | 1/4 | 25 | 300 | 9/16" x 18 UNF (female) | 9/16" x 18 UNF (female) | 8 | x | 14 3/4 | x | 13 5/8 | 25.9 | 167.00 |
| TLZ488 | Spring | 1/4 | 50 | 300 | 9/16" x 18 UNF (female) | 9/16" x 18 UNF (female) | 8 5/8 | x | 20 1/2 | x | 20 1/2 | 42.2 | 225.00 |

AIR/WATER DELIVERY REELS

- Lightweight and easy to handle
- Made of corrosion proof polypropylene
- Working temperature to 65°C
- Designed to protect the hose and allow for easy cleaning of both hose and reel
- Wall or floor mount (floor stand not included)
- Hose included

REELCRAFT



FH821

| Model No. | Mfg. No. | Hose I.D." | Hose Length' | Max PSI | Hose Outlet (M) NPT" | Reel Inlet (F) NPT" | Dimensions | | | | Wt. lbs. | Price /Each | |
|-----------|-------------|------------|--------------|---------|----------------------|---------------------|------------|---|----|---|----------|-------------|--------|
| | | | | | | | W" | x | D" | x | H" | | |
| FH821 | SGA3650 OLP | 3/8 | 50 | 232 | 3/8 | 3/8 | 9 1/8 | x | 22 | x | 19 3/8 | 21 | 379.00 |
| FH822 | SGA3665 OLP | 3/8 | 65 | 232 | 3/8 | 3/8 | 9 1/8 | x | 22 | x | 19 3/8 | 25 | 409.00 |
| FH823 | SGA3850 OLP | 1/2 | 50 | 232 | 1/2 | 1/2 | 9 1/8 | x | 22 | x | 19 3/8 | 23 | 389.00 |

LIGHTWEIGHT & ECONOMICAL INDUSTRIAL REELS

- Lighter spring driven hose reel designed for applications that are less demanding, yet require a product that can withstand industrial use
- Steel components are individually powder coated and teamed with composite materials, which virtually eliminates corrosion

REELCRAFT



FH522

STEEL & COMPOSITE REELS

| Model No. | Mfg. No. | Drive Type | Hose I.D." | Hose Length' | Max PSI | Hose Outlet (M) NPT" | Reel Inlet (F) NPT" | Reel Outlet (F) NPT" | Dimensions | | | | Wt. lbs. | Price /Each | |
|-----------|-----------|------------|------------|--------------|---------|----------------------|---------------------|----------------------|------------|---|--------|---|----------|-------------|--------|
| | | | | | | | | | W" | x | D" | x | H" | | |
| FH522 | RT435-OLP | Spring | 1/4 | 35 | 300 | 1/4 | 3/8 | - | 5 3/4 | x | 16 1/2 | x | 17 7/8 | 20 | 239.00 |
| FH523 | RT450-OLP | Spring | 1/4 | 50 | 300 | 1/4 | 3/8 | - | 5 3/4 | x | 16 1/2 | x | 17 7/8 | 24 | 289.00 |
| FH524 | RT635-OLP | Spring | 3/8 | 35 | 300 | 1/4 | 3/8 | - | 5 3/4 | x | 16 1/2 | x | 17 7/8 | 21 | 269.00 |
| FH525 | RT650-OLP | Spring | 3/8 | 50 | 300 | 1/4 | 1/2 | - | 6 1/4 | x | 16 1/2 | x | 17 7/8 | 27 | 349.00 |
| FI056 | RT835-OLP | Spring | 1/2 | 35 | 300 | 1/2 | 1/2 | - | 6 1/4 | x | 16 1/2 | x | 17 7/8 | 27 | 369.00 |
| FI057 | RT850-OLP | Spring | 1/2 | 50 | 300 | 1/2 | 1/2 | - | 7 3/4 | x | 16 1/2 | x | 17 7/8 | 37 | 469.00 |

2-Year Limited Warranty Standard colour as shown - black composite / powder coat paint red base & guide arm

Looking for a workbench?
Refer to pages 112 - 121



HOSE REELS

REELS CONTRIBUTE TO AN IMPROVED WORK ENVIRONMENT WHICH SAVES TIME, EQUIPMENT & MONEY

Standard features Include:

- Durable, corrosion-resistant powder coat paint
- Heavy-duty, reinforced steel stampings for increased strength
- Permanently lubricated for long, trouble-free service
- Multi-position guide arms for versatile mounting options
- Kinkless, high quality hoses
- Spring rewind features long life spring with declutching arbor

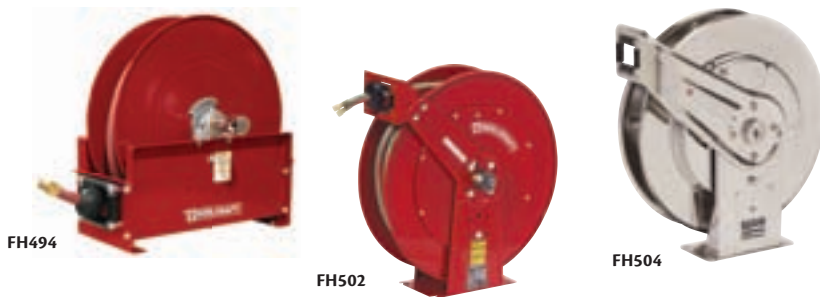

REELCRAFT

HEAVY-DUTY INDUSTRIAL STEEL REELS

| Model No. | Mfg. No. | Drive Type | Hose I.D." | Hose Length' | Max PSI | Hose Outlet (M)NPT" | Reel Inlet (F)NPT" | Reel Outlet (F)NPT" | W" | Dimensions D" x H" | Wt. lbs. | Price /Each |
|---|------------|------------|------------|--------------|---------|---------------------|--------------------|---------------------|--------|--------------------|----------|-------------|
| AIR or WATER reels for manufacturing plants, body shops, workshops, service stations, fabricators, spray booths - sold with hose | | | | | | | | | | | | |
| TN315 | 4435-OLP | Spring | 1/4 | 35 | 300 | 1/4 | 3/8 | - | 5 5/8 | x 12 3/8 x 12 7/8 | 19 | 309.00 |
| TN317 | 4625-OLP | Spring | 3/8 | 25 | 300 | 1/4 | 3/8 | - | 5 5/8 | x 12 3/8 x 12 7/8 | 20 | 319.00 |
| TN316 | 5635-OLP | Spring | 3/8 | 35 | 300 | 1/4 | 3/8 | - | 6 1/8 | x 14 x 14 3/8 | 25 | 388.00 |
| TN318 | 7650-OLP | Spring | 3/8 | 50 | 300 | 1/4 | 1/2 | - | 7 | x 19 3/4 x 20 1/4 | 43 | 579.00 |
| TN319 | 7850-OLP | Spring | 1/2 | 50 | 300 | 3/8 | 1/2 | - | 7 | x 19 3/4 x 20 1/4 | 47 | 599.00 |
| FI058 | 5450-OLP | Spring | 1/4 | 50 | 300 | 1/4 | 3/8 | - | 6 1/8 | x 14 x 14 3/8 | 26 | 409.00 |
| FH533 | 5650-OLP | Spring | 3/8 | 50 | 300 | 1/4 | 3/8 | - | 5 7/8 | x 16 1/2 x 17 5/8 | 36 | 469.00 |
| FH534 | 81100-OLP | Spring | 3/8 | 100 | 300 | 3/8 | 1/2 | - | 10 1/2 | x 24 x 25 3/8 | 82 | 929.00 |
| FH490 | 82100-OLP | Spring | 1/2 | 100 | 300 | 1/2 | 1/2 | - | 10 1/2 | x 24 x 25 3/8 | 95 | 959.00 |
| FH491 | 83050-OLP | Spring | 3/4 | 50 | 250 | 3/4 | 3/4 | - | 10 1/2 | x 24 x 25 3/8 | 88 | 929.00 |
| FH492 | D83075-OLP | Spring | 3/4 | 75 | 250 | 3/4 | 3/4 | - | 13 | x 24 x 25 3/8 | 102 | 1149.00 |
| FH493 | D84050-OLP | Spring | 1 | 50 | 250 | 3/4 | 1 | - | 15 3/4 | x 24 x 25 3/8 | 103 | 1175.00 |
| FH494 | E9350-OLP | Spring | 3/4 | 50 | 250 | 3/4 | 3/4 | - | 16 3/4 | x 26 1/4 x 26 3/8 | 140 | 1349.00 |
| FH495 | E9450-OLP | Spring | 1 | 50 | 250 | 3/4 | 1 | - | 16 3/4 | x 26 1/4 x 26 3/8 | 157 | 1419.00 |

| | | | | | | | | | | | | |
|--|----------|--------|-----|----|------|-----|-----|---|---|-------------------|----|--------|
| OIL - medium pressure - furnished standard with S.A.E. 100 RTT one wire braid hose - sold with hose | | | | | | | | | | | | |
| TN323 | 7850-OMP | Spring | 1/2 | 50 | 3250 | 1/2 | 1/2 | - | 7 | x 19 3/4 x 20 1/4 | 57 | 789.00 |

| | | | | | | | | | | | | |
|---|----------|--------|-----|----|------|-----|-----|---|---|-------------------|----|--------|
| GREASE or HYDRAULIC OIL - high pressure reel - furnished standard with S.A.E. 100 R2T two wire braid hose - sold with hose | | | | | | | | | | | | |
| TN325 | 7650-OHP | Spring | 3/8 | 50 | 4800 | 1/4 | 1/2 | - | 7 | x 19 3/4 x 20 1/4 | 60 | 869.00 |

| | | | | | | | | | | | | |
|---|-------------|--------|-----|-----|------|---|-----|-----|--------|-------------------|----|--------|
| WASHDOWN - high pressure reel with maximum product delivery - equipment cleaning, pressure washing - sold without hose | | | | | | | | | | | | |
| FI059 | PW7600-OHP | Spring | 3/8 | 50 | 5000 | - | 1/2 | 3/8 | 7 | x 19 3/4 x 20 1/4 | 43 | 599.00 |
| FH496 | PW81000-OHP | Spring | 3/8 | 100 | 5000 | - | 1/2 | 1/2 | 10 1/2 | x 24 x 25 3/8 | 86 | 909.00 |

| | | | | | | | | | | | | |
|--|-------------|--------|-----|----|------|-----|-----|---|----|---------------|-----|---------|
| DUAL HYDRAULIC - medium pressure reel ideal for operating hydraulic cylinders, tools and equipment - sold with hose | | | | | | | | | | | | |
| FH497 | TH88050-OMP | Spring | 1/2 | 50 | 2000 | 1/2 | 1/2 | - | 13 | x 24 x 25 3/8 | 114 | 1799.00 |

| | | | | | | | | | | | | |
|---|-------------|--------|-----|----|-----|-----|-----|---|--------|-------------------|-----|---------|
| FUEL DELIVERY - low pressure equipped with Viton® seals & fuel grade hose for mobile & permanent mount applications - sold with hose | | | | | | | | | | | | |
| FH498 | F7925-OLP | Spring | 3/4 | 25 | 250 | 3/4 | 3/4 | - | 7 | x 19 3/4 x 20 1/4 | 47 | 739.00 |
| FH499 | F83050-OLP | Spring | 3/4 | 50 | 250 | 3/4 | 3/4 | - | 10 1/2 | x 24 x 25 3/8 | 89 | 1249.00 |
| FH500 | FD84050-OLP | Spring | 1 | 50 | 250 | 1 | 1 | - | 15 3/4 | x 24 x 25 3/8 | 120 | 1369.00 |

| | | | | | | | | | | | | |
|---|--------------|--------|-----|-----|-----|--------|--------|---|-------|-------------------|-----|---------|
| WELDING REELS - used for a wide variety of gases such as acetylene, Mapp gas, propane gas, natural gas and fuel gases - sold with hose | | | | | | | | | | | | |
| FH501 | TW7450-OLPT | Spring | 1/4 | 50 | 200 | note 1 | 1/4 | - | 7 3/8 | x 19 3/4 x 20 1/4 | 50 | 709.00 |
| FH502 | TW84100-OLPT | Spring | 1/4 | 100 | 200 | note 1 | note 2 | - | 13 | x 24 x 25 3/8 | 101 | 1399.00 |

| | | | | | | | | | | | | |
|---|----------|--------|-----|----|------|---|-----|-----|-------|-------------------|----|---------|
| STAINLESS STEEL for AIR, WATER or OIL - corrosion-resistant reels - swivels include Viton® O-rings - sold without hose | | | | | | | | | | | | |
| FH503 | 5600-OLS | Spring | 3/8 | 35 | 500 | - | 3/8 | 3/8 | 6 1/8 | x 14 x 14 3/8 | 22 | 899.00 |
| FH504 | 7800-OLS | Spring | 1/2 | 50 | 500 | - | 1/2 | 1/2 | 7 | x 19 3/4 x 20 1/4 | 41 | 1299.00 |
| FH505 | 7800-OMS | Spring | 1/2 | 50 | 3000 | - | 1/2 | 1/2 | 7 | x 19 3/4 x 20 1/4 | 45 | 1449.00 |

| | | | | | | | | | | | | |
|---|----------|--------|-----|-----|------|---|-----|--------|--------|-------------------|----|--------|
| HAND CRANK for AIR or WATER - designed for medium-duty applications requiring longer lengths of hose - sold without hose | | | | | | | | | | | | |
| FH506 | CA32106L | Manual | 1/2 | 100 | 1000 | - | 1/2 | 1/2 | 19 3/4 | x 17 3/4 x 20 1/4 | 40 | 329.00 |
| FH507 | CA32112L | Manual | 1/2 | 200 | 1000 | - | 1/2 | 1/2 | 25 3/4 | x 17 3/4 x 20 1/4 | 46 | 329.00 |
| FH508 | CA33112L | Manual | 3/4 | 100 | 1000 | - | 3/4 | 3/4 | 19 3/4 | x 17 3/4 x 20 1/4 | 46 | 429.00 |
| FI060 | CB37118L | Manual | 1 | 100 | 300 | - | 1 | note 3 | 34 | x 17 3/4 x 20 1/4 | 52 | 509.00 |

| | | | | | | | | | | | | |
|--|----------|---|---|---|---|---|---|---|--------|---------------|---|--------|
| HOSE REEL CART FOR 12" HAND CRANK REELS - 8" semi-pneumatic rubber tires, adjustable handle, rugged 1" square tubular steel frame | | | | | | | | | | | | |
| FH509 | 600741-2 | - | - | - | - | - | - | - | 23 3/4 | x 27 x note 4 | - | 219.00 |

2-Year Limited Warranty - Note 1: 9/16" - 18 UNF Female Note 2: 9/16" - 18 UNF Male Note 3: 1" NPTM Note 4: Handle height adjustable to 35 5/8", 38 5/8", 41 1/2", 44 1/2" Standard colour as shown - powder coat paint red

HOSE REELS

- Heavy-duty, reinforced steel stampings for increased strength
- For use with air and water
- Compact design allows reels to fit in tight locations
- Multi-position guide arms for multiple mounting options

- Kinkless, oil resistant high quality hose
- Spring rewind features long life spring with declutching arbor
- Durable, corrosion-resistant powder coat paint

| Model No. | Drive Type | Hose I.D." | Hose Length' | Max PSI | Hose Outlet (M) NPT" | Reel Inlet (F) NPT" | Dimensions W" x D" x H" | Wt. lbs. | Price /Each |
|-----------|------------|------------|--------------|---------|----------------------|---------------------|-------------------------|----------|-------------|
| TLZ482 | Spring | 1/4 | 35 | 300 | 1/4 | 3/8 | 6 x 15 1/2 x 14 | 26.6 | 216.00 |
| TLZ483 | Spring | 3/8 | 25 | 300 | 1/4 | 3/8 | 6 x 15 1/8 x 13 7/8 | 26.2 | 221.00 |
| TLZ484 | Spring | 3/8 | 35 | 300 | 1/4 | 3/8 | 6 5/8 x 17 1/2 x 16 1/2 | 34.7 | 267.00 |
| TLZ485 | Spring | 3/8 | 50 | 300 | 1/4 | 3/8 | 6 1/2 x 20 x 18 3/8 | 40.3 | 361.00 |
| TLZ486 | Spring | 1/2 | 50 | 300 | 1/2 | 1/2 | 6 5/8 x 20 1/4 x 17 7/8 | 44.3 | 378.00 |



HOSES & HOSE CLAMPS

HOSE CLAMPS

STAINLESS STEEL BAND & SCREW



5/16" HEX HEAD SCREW 1/2" BAND

| Model No. | Mfg. No. | Diameter Min." | Diameter Max." | Price/Each |
|-----------|----------|----------------|----------------|------------|
| TLY173 | DHCS-6 | 0.375 | 0.875 | 1.55 |
| TLY177 | DHCS-8 | 0.438 | 1 | 1.57 |
| TLY152 | DHCS-10 | 0.5 | 1.125 | 1.66 |
| TLY154 | DHCS-12 | 0.5 | 1.25 | 1.66 |
| TLY157 | DHCS-16 | 0.75 | 1.5 | 1.73 |
| TLY160 | DHCS-20 | 0.75 | 1.75 | 1.84 |
| TLY164 | DHCS-24 | 1 | 2 | 1.91 |
| TLY165 | DHCS-28 | 1.313 | 2.25 | 2.00 |
| TLY166 | DHCS-32 | 1.563 | 2.5 | 2.00 |
| TLY167 | DHCS-36 | 0.875 | 2.75 | 2.02 |
| TLY168 | DHCS-40 | 1.125 | 3 | 2.02 |
| TLY169 | DHCS-44 | 1.313 | 3.25 | 2.09 |
| TLY170 | DHCS-48 | 1.625 | 3.5 | 2.13 |
| TLY171 | DHCS-52 | 1.875 | 3.75 | 3.17 |
| TLY172 | DHCS-56 | 2.125 | 4 | 2.28 |
| TLY175 | DHCS-64 | 2.625 | 4.5 | 2.35 |
| TLY176 | DHCS-72 | 3.125 | 5 | 2.58 |
| TLY178 | DHCS-80 | 3.625 | 5.5 | 3.08 |
| TLY180 | DHCS-88 | 4.25 | 6 | 2.69 |
| TLY181 | DHCS-96 | 4.75 | 6.5 | 2.82 |
| TLY153 | DHCS-104 | 4 | 7 | 2.82 |
| TLY155 | DHCS-128 | 6.5 | 8.5 | 3.51 |
| TLY156 | DHCS-152 | 8 | 10 | 5.32 |
| TLY158 | DHCS-164 | 8.75 | 10.75 | 5.96 |
| TLY159 | DHCS-188 | 10.25 | 12.25 | 6.74 |
| TLY161 | DHCS-212 | 11.75 | 13.75 | 7.79 |

HOSE CLAMPS

STAINLESS STEEL BAND & ZINC PLATED SCREW



5/16" HEX HEAD SCREW 1/2" BAND

| Model No. | Mfg. No. | Diameter Min." | Diameter Max." | Price/Each |
|-----------|----------|----------------|----------------|------------|
| TLY205 | DHC6-6 | 0.375 | 0.875 | 1.01 |
| TLY208 | DHC6-8 | 0.438 | 1 | 1.10 |
| TLY182 | DHC6-10 | 0.5 | 1.125 | 1.10 |
| TLY185 | DHC6-12 | 0.5 | 1.25 | 1.15 |
| TLY188 | DHC6-16 | 0.75 | 1.5 | 1.12 |
| TLY191 | DHC6-20 | 0.75 | 1.75 | 1.19 |
| TLY195 | DHC6-24 | 1 | 2 | 1.17 |
| TLY196 | DHC6-28 | 1.313 | 2.25 | 1.24 |
| TLY198 | DHC6-32 | 1.563 | 2.5 | 1.24 |
| TLY199 | DHC6-36 | 0.875 | 2.75 | 1.33 |
| TLY200 | DHC6-40 | 1.125 | 3 | 1.37 |
| TLY201 | DHC6-44 | 1.313 | 3.25 | 1.55 |
| TLY202 | DHC6-48 | 1.625 | 3.5 | 1.57 |
| TLY203 | DHC6-52 | 1.875 | 3.75 | 1.60 |
| TLY204 | DHC6-56 | 2.125 | 4 | 1.66 |
| TLY206 | DHC6-64 | 2.625 | 4.5 | 1.84 |
| TLY207 | DHC6-72 | 3.125 | 5 | 1.87 |
| TLY209 | DHC6-80 | 3.625 | 5.5 | 2.05 |
| TLY210 | DHC6-88 | 4.25 | 6 | 2.02 |
| TLY211 | DHC6-96 | 4.75 | 6.5 | 2.09 |
| TLY183 | DHC6-104 | 4 | 7 | 2.65 |
| TLY184 | DHC6-116 | 5.75 | 7.75 | 4.80 |
| TLY186 | DHC6-128 | 6.5 | 8.5 | 3.17 |
| TLY187 | DHC6-152 | 8 | 10 | 4.22 |
| TLY189 | DHC6-164 | 8.75 | 10.75 | 4.31 |
| TLY190 | DHC6-188 | 10.25 | 12.25 | 7.08 |
| TLY760 | DHC6-200 | 11 | 13 | 6.01 |
| TLY192 | DHC6-212 | 11.75 | 13.75 | 6.57 |

HOSE CLAMPS

STAINLESS STEEL BAND & SCREW



MINI-GEAR 1/4" HEX HEAD SCREW 5/16" BANDS

| Model No. | Mfg. No. | Diameter Min." | Diameter Max." | Price/Each |
|-----------|----------|----------------|----------------|------------|
| TLY283 | DMHCS-4 | 0.219 | 0.625 | 1.57 |
| TLY284 | DMHCS-6 | 0.316 | 0.875 | 1.96 |
| TLY285 | DMHCS-8 | 0.438 | 1 | 2.07 |
| TLY281 | DMHCS-12 | 0.563 | 1.25 | 2.76 |

HOSE CLAMPS

STAINLESS STEEL BAND & ZINC PLATED SCREW



MINI-GEAR 1/4" HEX HEAD ZINC PLATED SCREW 5/16" BANDS

| Model No. | Mfg. No. | Diameter Min." | Diameter Max." | Price/Each |
|-----------|----------|----------------|----------------|------------|
| TLY289 | DMHCC-4 | 0.219 | 0.625 | 1.17 |
| TLY290 | DMHCC-5 | 0.438 | 0.6875 | 1.42 |
| TLY291 | DMHCC-6 | 0.438 | 0.875 | 1.33 |
| TLY292 | DMHCC-8 | 0.438 | 1 | 1.37 |
| TLY286 | DMHCC-10 | 0.5 | 1.063 | 1.48 |
| TLY287 | DMHCC-12 | 0.563 | 1.25 | 1.48 |
| TLY288 | DMHCC-16 | 0.813 | 1.75 | 1.66 |

2-EAR HOSE CLAMPS



| Model No. | Mfg. No. | Size" | Price/Each |
|-----------|----------|-------|------------|
| 320-2020 | 305 | 3/16 | 0.39 |
| 320-2040 | 507 | 1/4 | 0.39 |
| 320-2060 | 709 | 5/16 | 0.39 |
| 320-2070 | 811 | 3/8 | 0.42 |
| 320-2090 | 1113 | 1/2 | 0.45 |
| 320-2110 | 1315 | 9/16 | 0.48 |
| 320-2130 | 1517 | 19/32 | 0.50 |
| 320-2140 | 1518 | 5/8 | 0.52 |
| 320-2150 | 1720 | 3/4 | 0.59 |
| 320-2170 | 1922 | 13/16 | 0.85 |
| 320-2180 | 2023 | 7/8 | 0.69 |
| 320-2210 | 2327 | 1 | 0.74 |

1-EAR HOSE CLAMPS

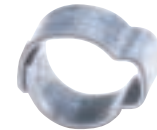

| Model No. | Mfg. No. | Size" | Price/Each |
|-----------|------------|-------|------------|
| TLY259 | DHC8-6 | 3/8 | 0.45 |
| TLY260 | DHC8-7 | 7/16 | 0.45 |
| TLY261 | DHC8-7 1/2 | 15/32 | 0.54 |
| TLY262 | DHC8-8 1/2 | 1/2 | 0.45 |
| TLY264 | DHC8-9 | 9/16 | 0.45 |
| TLY212 | DHC8-10 | 5/8 | 0.52 |
| TLY213 | DHC8-11 | 11/16 | 0.49 |
| TLY215 | DHC8-12 | 3/4 | 0.52 |
| TLY216 | DHC8-13 | 13/16 | 0.52 |
| TLY217 | DHC8-14 | 7/8 | 0.49 |
| TLY218 | DHC8-15 | 15/16 | 0.52 |
| TLY219 | DHC8-16 | 1 | 0.52 |

KEY TURN HOSE CLAMPS

- Zinc Plated Screw
Stainless Steel Band
- TLY752 and TLY753 will accept 22 to 24 inch/lbs. of torque on the key
- Item TLY754 to TLY758 will accept 40 to 50 inch/lbs. of torque on the key



TWO EAR CLAMP

| Model No. | Mfg. No. | Size | Price/Each |
|-----------|------------|--------------|------------|
| TLY752 | DKTC12-04 | 6-16 mm | 0.47 |
| TLY753 | DKTC12-06 | 8-22 mm | 0.47 |
| TLY754 | DKTC12-12 | 12.7-31.7 mm | 0.90 |
| TLY755 | DKTC12-20 | 19-44.4 mm | 0.97 |
| TLY756 | DKTC12-28 | 31.7-57 mm | 2.07 |
| TLY757 | DKTC12-36 | 44.4-69.8 mm | 1.03 |
| TLY758 | DKTC12-100 | 100-125 mm | 1.78 |

FITTINGS, COUPLERS & VALVES

P.T.C. TEES



TS681



BC209

| Size" | Brass Model No. | Price /Each | Composite Model No. | Price /Each |
|-------|-----------------|-------------|---------------------|-------------|
| 1/8 | TS681 | 8.75 | BC209 | 3.55 |
| 5/32 | TS682 | 8.75 | TLY824 | 1.73 |
| 3/16 | TDX116 | 13.20 | - | - |
| 1/4 | TS683 | 9.38 | TLY823 | 1.84 |
| 3/8 | TQ873 | 13.80 | TLY825 | 2.35 |
| 1/2 | TS685 | 18.90 | TLY826 | 2.41 |

P.T.C. SWIVEL MALE BRANCH TEES



TLY769



BT502

| Size" | Brass Model No. | Price /Each | Composite Model No. | Price /Each |
|--------------|-----------------|-------------|---------------------|-------------|
| 1/8 x 1/8 | TLY769 | 19.30 | TA360 | 9.64 |
| 5/32 x 1/8 | TS674 | 11.30 | BT502 | 2.85 |
| 5/32 x 10-32 | TBV373 | 17.70 | TLY785 | 13.30 |
| 1/4 x 1/8 | TS675 | 11.30 | BT522 | 4.25 |
| 1/4 x 1/4 | TS676 | 11.90 | BT523 | 4.25 |
| 3/8 x 1/4 | TS677 | 15.60 | BT526 | 4.98 |
| 3/8 x 3/8 | TS678 | 16.60 | BT527 | 4.98 |
| 1/2 x 3/8 | TBV476 | 28.40 | BC208 | 7.44 |
| 1/2 x 1/2 | TBV477 | 37.70 | TA369 | 7.99 |

P.T.C. MALE CONNECTORS



TS625



TS987

| Size" | Brass Model No. | Price /Each | Composite Model No. | Price /Each |
|--------------|-----------------|-------------|---------------------|-------------|
| 1/8 x 1/8 | TS625 | 4.24 | TS987 | 1.90 |
| 5/32 x 1/8 | TS627 | 4.24 | TS989 | 1.93 |
| 5/32 x 1/4 | TS628 | 4.24 | TS990 | 2.05 |
| 5/32 x 10-32 | TBX570 | 5.73 | TS988 | 1.93 |
| 3/16 x 10-32 | TBU474 | 10.00 | - | - |
| 3/16 x 1/8 | TBX862 | 6.83 | - | - |
| 1/4 x 10-32 | TBX571 | 9.73 | BC200 | 2.05 |
| 1/4 x 5/32 | TLY765 | 10.80 | - | - |
| 1/4 x 1/8 | TS629 | 4.47 | TLV009 | 1.60 |
| 1/4 x 1/4 | TQ876 | 4.47 | TLV010 | 1.78 |
| 1/4 x 3/8 | TBY078 | 7.56 | TLV011 | 4.82 |
| 3/8 x 1/8 | TS631 | 6.82 | TLV012 | 2.02 |
| 3/8 x 1/4 | TS632 | 6.82 | TLV013 | 2.45 |
| 3/8 x 3/8 | TS633 | 6.82 | TLV014 | 2.28 |
| 3/8 x 1/2 | TS634 | 12.20 | TLV015 | 3.64 |
| 1/2 x 1/4 | TS635 | 9.29 | TLV016 | 3.25 |
| 1/2 x 3/8 | TQ878 | 9.29 | TLV017 | 3.45 |
| 1/2 x 1/2 | TQ879 | 9.29 | TLV018 | 8.18 |

P.T.C. UNION



TA338

| Composite Model No. | Tube Size" | Thread Size" | Price /Each |
|---------------------|------------|--------------|-------------|
| TA338 | 1/8 | 1/8 | 7.13 |
| TA339 | 1/4 | 1/4 | 7.33 |
| TA340 | 3/8 | 3/8 | 10.20 |
| TA342 | 1/2 | 1/2 | 11.10 |

P.T.C. MALE RUN TEES



TBY624



TA374

| Size" | Brass Model No. | Price /Each | Composite Model No. | Price /Each |
|------------|-----------------|-------------|---------------------|-------------|
| 1/8 x 1/8 | TBY624 | 10.20 | TA374 | 9.64 |
| 5/32 x 1/8 | TBY326 | 10.70 | TLY818 | 3.04 |
| 3/16 x 1/8 | TBY327 | 12.50 | - | - |
| 1/4 x 1/8 | TBY625 | 11.50 | TLY816 | 2.97 |
| 1/4 x 1/4 | TBY626 | 13.60 | TLY817 | 2.97 |
| 3/8 x 1/8 | TBY627 | 14.80 | TLY819 | 2.97 |
| 3/8 x 1/4 | TBY628 | 17.40 | TLY820 | 2.97 |
| 3/8 x 3/8 | TBY629 | 19.10 | TLY821 | 3.62 |
| 1/2 x 3/8 | TBY630 | 20.60 | TLY822 | 5.30 |

P.T.C. QUICK DISCONNECT



TBX574



TS991

| Size" | Brass Model No. | Price /Each | Composite Model No. | Price /Each |
|-----------|-----------------|-------------|---------------------|-------------|
| 1/4 x 1/8 | TBX574 | 29.80 | TS991 | 2.05 |
| 1/4 x 1/4 | TBX575 | 30.90 | TS992 | 2.09 |
| 3/8 x 1/4 | TBX576 | 32.90 | TS998 | 2.78 |

P.T.C. MALE ELBOWS 90°



TS651



BT500

| Size" | Brass Swivel Model No. | Price /Each | Brass Non Swivel Model No. | Price /Each | Composite Swivel Model No. | Price /Each |
|--------------|------------------------|-------------|----------------------------|-------------|----------------------------|-------------|
| 1/8 x 1/8 | TS651 | 5.70 | TBX012 | 6.98 | BT500 | 2.93 |
| 5/32 x 1/8 | TQ880 | 5.70 | TS643 | 5.33 | TLY845 | 2.93 |
| 5/32 x 1/4 | TS653 | 5.70 | - | - | BT503 | 2.93 |
| 5/32 x 10-32 | TS652 | 5.70 | - | - | BT501 | 2.93 |
| 1/4 x 10-32 | TBV119 | 11.20 | - | - | BC206 | 2.93 |
| 1/4 x 1/8 | TQ881 | 6.60 | TS644 | 5.33 | BT504 | 2.93 |
| 1/4 x 1/4 | TS654 | 7.41 | TQ877 | 5.33 | BT505 | 2.93 |
| 1/4 x 3/8 | TBX015 | 19.10 | TLY767 | 14.20 | BT506 | 3.32 |
| 3/8 x 1/8 | TS655 | 11.20 | TBX016 | 9.56 | TLY847 | 2.28 |
| 3/8 x 1/4 | TS656 | 11.20 | TS647 | 9.34 | TLY848 | 6.89 |
| 3/8 x 3/8 | TS657 | 11.20 | TQ884 | 9.34 | TLY849 | 8.35 |
| 3/8 x 1/2 | TU961 | 11.20 | - | - | TA351 | 13.90 |
| 1/2 x 3/8 | TQ883 | 13.60 | TBX020 | 14.80 | BT514 | 6.94 |
| 1/2 x 1/2 | TS658 | 13.60 | - | - | TLY851 | 4.31 |

TUBING

- Roll length: 100'

NYLON TUBING

- Working temperature: -60 to 200°F, -40°C to 80°C

POLYETHYLENE TUBING

- Working temperature: -50° to 140° F, -45° to 60°C



| Model No. | Tube O.D." | Tube I.D." | Maximum Working Pressure PSI | Price /Each |
|----------------------------|------------|------------|------------------------------|-------------|
| NYLON TUBING | | | | |
| TA299 | 1/4 | 0.180 | 250 | 63.10 |
| TA301 | 3/8 | 0.275 | 250 | 123.00 |
| TA302 | 1/2 | 0.375 | 250 | 203.00 |
| POLYETHYLENE TUBING | | | | |
| TA309 | 1/4 | 0.170 | 140 | 29.90 |
| TA310 | 3/8 | 0.250 | 125 | 48.80 |
| TA311 | 1/2 | 0.375 | 100 | 60.50 |

FITTINGS, COUPLERS & VALVES

HEX PIPE NIPPLES



TDV543

Brass Pipe Fittings

| Size" | Model No. | Mfg. No. | Price/Each |
|-------|-----------|----------|------------|
| 1/8 | TDV543 | D122-A | 0.88 |
| 1/4 | TDV544 | D122-B | 1.37 |
| 3/8 | TDV545 | D122-C | 2.26 |
| 1/2 | TDV546 | D122-D | 3.47 |
| 3/4 | TDV547 | D122-E | 5.47 |
| 1 | TDV816 | D122-F | 13.50 |

PIPE PLUGS COUNTERSUNK HEX



TDV418

Brass Pipe Fittings

| Size" | Model No. | Mfg. No. | Price/Each |
|-------|-----------|----------|------------|
| 1/8 | TDV418 | D118-A | 0.61 |
| 1/4 | TDV419 | D118-B | 0.83 |
| 3/8 | TDV420 | D118-C | 1.17 |
| 1/2 | TDV421 | D118-D | 2.35 |
| 3/4 | TDV422 | D118-E | 4.74 |

PIPE PLUG HEX HEADS



TDV045

Brass Pipe Fittings

| Size" | Model No. | Mfg. No. | Price/Each |
|-------|-----------|----------|------------|
| 1/8 | TDV045 | D121-A | 0.58 |
| 1/4 | TDV046 | D121-B | 0.83 |
| 3/8 | TDV047 | D121-C | 1.28 |
| 1/2 | TDV048 | D121-D | 2.56 |
| 3/4 | TDV049 | D121-E | 4.03 |
| 1 | TDV432 | D121-F | 10.60 |

PIPE ADAPTERS

FEMALE TO MALE
REDUCING



TDV424

Brass Pipe Fittings

| Size" | Model No. | Mfg. No. | Price/Each |
|-----------|-----------|----------|------------|
| 1/4 x 1/8 | TDV424 | D120-BA | 1.53 |
| 3/8 x 1/8 | TBV820 | D120-CA | 2.58 |
| 3/8 x 1/4 | TDV426 | D120-CB | 2.50 |
| 1/2 x 1/4 | TDV428 | D120-DB | 4.00 |
| 1/2 x 3/8 | TDV429 | D120-DC | 3.42 |
| 3/4 x 1/2 | TDV431 | D120-ED | 6.35 |

PIPE BUSHINGS



TDV406

Brass Pipe Fittings

| Size" | Model No. | Mfg. No. | Price/Each |
|-----------|-----------|----------|------------|
| 1/4 x 1/8 | TDV406 | D110-BA | 0.76 |
| 3/8 x 1/8 | TDV407 | D110-CA | 1.39 |
| 3/8 x 1/4 | TDV408 | D110-CB | 1.12 |
| 1/2 x 1/8 | TDV409 | D110-DA | 2.26 |
| 1/2 x 1/4 | TDV410 | D110-DB | 1.98 |
| 1/2 x 3/8 | MLM712 | D110-DC | 1.91 |
| 3/4 x 1/8 | TDV412 | D110-EA | 8.76 |
| 3/4 x 1/4 | TDV413 | D110-EB | 3.60 |
| 3/4 x 3/8 | MLM590 | D110-EC | 3.66 |
| 3/4 x 1/2 | TDV415 | D110-ED | 3.08 |
| 1 x 1/4 | TDV668 | D110-FB | 10.40 |
| 1 x 3/8 | TDV669 | D110-FC | 9.69 |
| 1 x 1/2 | TDV670 | D110-FD | 8.31 |
| 1 x 3/4 | TDV671 | D110-FE | 6.46 |

MALE PIPE ELBOWS 90°



TDX340

Brass Pipe Fittings

| Size" | Model No. | Mfg. No. | Price/Each |
|-----------|-----------|----------|------------|
| 1/8 | TDX340 | D99-A | 5.32 |
| 1/4 | TDX341 | D99-B | 5.40 |
| 1/4 x 1/8 | TDX231 | D99-BA | 7.54 |
| 3/8 | TDX342 | D99-C | 10.30 |
| 3/8 x 1/4 | TDX232 | D99-CB | 9.60 |
| 1/2 | TDX343 | D99-D | 12.80 |
| 1/2 x 3/8 | TDX233 | D99-DC | 10.90 |

HEX PIPE NIPPLES REDUCING



MLM721

Brass Pipe Fittings

| Size" | Model No. | Mfg. No. | Price/Each |
|-----------|-----------|----------|------------|
| 1/4 x 1/8 | MLM721 | D122-BA | 1.44 |
| 3/8 x 1/4 | TBX435 | D122-CB | 2.20 |
| 1/2 x 1/4 | TBX436 | D122-DB | 3.94 |
| 3/4 x 1/2 | TBX438 | D122-ED | 5.90 |

BRANCH TEES EXTRUDED MALE ON BRANCH



TDX155

Brass Pipe Fittings

| Size" | Model No. | Mfg. No. | Price/Each |
|-------|-----------|----------|------------|
| 1/8 | TDX155 | D106-A | 3.94 |
| 1/4 | TDX156 | D106-B | 5.88 |
| 3/8 | TDX157 | D106-C | 8.23 |
| 1/2 | TDX234 | DF106-D | 13.50 |

PIPE COUPLINGS



TDV799

Brass Pipe Fittings

| Size" | Model No. | Mfg. No. | Price/Each |
|-------|-----------|----------|------------|
| 1/8 | TDV799 | D103-A | 1.24 |
| 1/4 | TDV800 | D103-B | 1.91 |
| 3/8 | TDV801 | D103-C | 2.52 |
| 1/2 | TDV802 | D103-D | 4.18 |
| 3/4 | TDV803 | D103-E | 4.50 |

HEX PIPE NIPPLES REDUCING



TBX434

Brass Pipe Fittings

| Size" | Model No. | Mfg. No. | Price/Each |
|-----------|-----------|----------|------------|
| 3/8 x 1/8 | TBX434 | D122-CA | 3.66 |
| 1/2 x 3/8 | TBX437 | D122-DC | 3.38 |

PIPE CAPS



TDX291

Brass Pipe Fittings

| Size" | Model No. | Mfg. No. | Price/Each |
|-------|-----------|----------|------------|
| 1/8 | TDX291 | D108-A | 1.15 |
| 1/4 | TDX292 | D108-B | 1.60 |
| 3/8 | TDX293 | D108-C | 2.41 |
| 1/2 | TDX294 | D108-D | 3.08 |
| 3/4 | TDX295 | D108-E | 6.65 |

MALE PIPE TEES



TDV950

Brass Pipe Fittings

| Size" | Model No. | Mfg. No. | Price/Each |
|-------|-----------|----------|------------|
| 1/8 | TDV950 | DM101-A | 6.42 |
| 1/4 | TDV951 | DM101-B | 5.60 |
| 3/8 | TDV952 | DM101-C | 8.59 |
| 1/2 | TBV137 | DM101-D | 14.80 |
| 3/4 | TBV138 | DM101-E | 32.00 |

PIPE ADAPTERS

FEMALE TO MALE



TDV423

Brass Pipe Fittings

| Size" | Model No. | Mfg. No. | Price/Each |
|-----------|-----------|----------|------------|
| 1/8 x 1/8 | TDV423 | D120-AA | 1.01 |
| 1/4 x 1/4 | TDV425 | D120-BB | 1.91 |
| 3/8 x 3/8 | TDV427 | D120-CC | 2.65 |
| 1/2 x 1/2 | TDV430 | D120-DD | 4.31 |

PIPE ELBOWS 45° EXTRUDED



TDV039

Brass Pipe Fittings

| Size" | Model No. | Mfg. No. | Price/Each |
|-------|-----------|----------|------------|
| 1/8 | TDV039 | D105-A | 7.64 |
| 1/4 | TDV040 | D105-B | 7.90 |

PIPE REDUCING COUPLINGS



TBZ106

Brass Pipe Fittings

| Size" | Model No. | Mfg. No. | Price/Each |
|-----------|-----------|----------|------------|
| 1/4 x 1/8 | TBZ106 | D119-BA | 2.24 |
| 3/8 x 1/8 | TBZ107 | D119-CA | 3.32 |
| 3/8 x 1/4 | TBZ108 | D119-CB | 2.76 |
| 1/2 x 1/4 | TBZ110 | D119-DB | 3.94 |
| 1/2 x 3/8 | TBZ111 | D119-DC | 4.16 |
| 1/2 x 1/8 | TBZ109 | D119-DA | 7.26 |
| 3/4 x 1/2 | TBZ113 | D119-ED | 6.44 |

SQUARE HEAD PIPE PLUGS



TBZ288

Brass Pipe Fittings

| Size" | Model No. | Mfg. No. | Price/Each |
|-------|-----------|----------|------------|
| 1/8 | TBZ288 | D109-A | 0.58 |
| 1/4 | TBZ289 | D109-B | 0.85 |
| 3/8 | TBZ290 | D109-C | 1.42 |
| 1/2 | TBZ291 | D109-D | 2.56 |
| 3/4 | TBZ292 | D109-E | 3.34 |
| 1 | TBZ819 | D109-F | 10.20 |

STREET TEES EXTRUDED



TDX159

Brass Pipe Fittings

| Size" | Model No. | Mfg. No. | Price/Each |
|-------|-----------|----------|------------|
| 1/8 | TA471 | 41.283 | 4.10 |
| 1/4 | TDX159 | D107-B | 3.73 |
| 3/8 | TDX160 | D107-C | 4.97 |
| 1/2 | TDX161 | D107-D | 8.91 |
| 3/4 | TBZ818 | D107-E | 30.10 |

FITTINGS, COUPLERS & VALVES

COMPRESSION ELBOWS 90°

TUBE TO TUBE

TBY758



| Model No. | Mfg. No. | Size" | Price/Each |
|-----------|----------|-----------|------------|
| TBY758 | D65-2 | 1/8 | 6.65 |
| TBY466 | D65-3 | 3/16 | 6.44 |
| TBY759 | D65-4 | 1/4 | 3.75 |
| TBY467 | D65-5 | 5/16 | 5.23 |
| TBY760 | D65-6 | 3/8 | 4.46 |
| TBY468 | D65-6-4 | 3/8 x 1/4 | 11.70 |
| TBY469 | D65-7 | 7/16 | 11.70 |
| TBY761 | D65-8 | 1/2 | 7.56 |
| TBY470 | D65-8-6 | 1/2 x 3/8 | 16.80 |

COMPRESSION REDUCING UNIONS

TBY002



| Model No. | Mfg. No. | Size" | Price/Each |
|-----------|----------|------------|------------|
| TBY002 | D62-8-6 | 1/2 x 3/8 | 3.96 |
| TBY001 | D62-4-2 | 1/4 x 1/8 | 4.35 |
| TBX694 | D62-4-3 | 1/4 x 3/16 | 6.98 |
| TBX695 | D62-5-4 | 5/16 x 1/4 | 6.93 |
| TBZ096 | D62-6-4 | 3/8 x 1/4 | 2.61 |
| TBX696 | D62-6-5 | 3/8 x 5/16 | 3.57 |
| TBY003 | D62-10-6 | 5/8 x 3/8 | 4.84 |
| TBY004 | D62-10-8 | 5/8 x 1/2 | 6.57 |

COMPRESSION ELBOWS 90°

TUBE TO MALE PIPE

TBX736



| Model No. | Mfg. No. | Size" | Price/Each |
|-----------|----------|------------|------------|
| TBX736 | D69-2A | 1/8 x 1/8 | 4.46 |
| TBX404 | D69-3A | 3/16 x 1/8 | 2.91 |
| TBX405 | D69-3B | 3/16 x 1/4 | 4.89 |
| TBX737 | D69-4A | 1/4 x 1/8 | 2.15 |
| TBX738 | D69-4B | 1/4 x 1/4 | 2.58 |
| TBX739 | D69-4C | 1/4 x 3/8 | 4.07 |
| TBX740 | D69-4D | 1/4 x 1/2 | 7.45 |
| TBX406 | D69-5A | 5/16 x 1/8 | 3.27 |
| TBX407 | D69-5B | 5/16 x 1/4 | 3.68 |
| TBX408 | D69-5C | 5/16 x 3/8 | 13.70 |
| TBX741 | D69-6A | 3/8 x 1/8 | 3.90 |
| TBX742 | D69-6B | 3/8 x 1/4 | 3.06 |
| TBX743 | D69-6C | 3/8 x 3/8 | 3.32 |
| TBX744 | D69-6D | 3/8 x 1/2 | 5.53 |
| TBX745 | D69-6E | 3/8 x 3/4 | 10.80 |
| TBX409 | D69-7B | 7/16 x 1/4 | 12.20 |

COMPRESSION SEALING PLUGS



| Model No. | Mfg. No. | Size" | Price/Each |
|-----------|----------|-------|------------|
| TDV405 | D67-4 | 1/4 | 5.04 |

COMPRESSION TEES

TUBE ALL ENDS

TDV528



| Model No. | Mfg. No. | Size" | Price/Each |
|-----------|-----------|------------------|------------|
| TDV528 | D64-2 | 1/8 | 6.74 |
| TDV402 | D64-3 | 3/16 | 4.54 |
| TDV529 | D64-4 | 1/4 | 4.26 |
| TBX377 | D64-4-2 | 1/4 x 1/4 x 1/8 | 11.50 |
| TBX169 | D64-4-3 | 1/4 x 1/4 x 3/16 | 11.00 |
| TBX378 | D64-4-6 | 1/4 x 1/4 x 3/8 | 13.20 |
| TDV403 | D64-5 | 5/16 | 6.46 |
| TDV530 | D64-6 | 3/8 | 5.94 |
| TBX379 | D64-6-4 | 3/8 x 3/8 x 1/4 | 12.80 |
| TBV652 | D64-6-4-4 | 3/8 x 1/4 x 1/4 | 13.60 |
| TDV531 | D64-8 | 1/2 | 9.67 |
| TBX380 | D64-8-4 | 1/2 x 1/2 x 1/4 | 22.20 |
| TBX381 | D64-8-6 | 1/2 x 1/2 x 3/8 | 20.00 |
| TDV532 | D64-10 | 5/8 | 12.00 |
| TBX382 | D64-10-8 | 5/8 x 5/8 x 1/2 | 24.60 |
| TDV533 | D64-12 | 3/4 | 39.40 |
| TDV534 | D64-14 | 7/8 | 38.50 |

COMPRESSION UNIONS

TDV239



| Model No. | Mfg. No. | Size" | Price/Each |
|-----------|----------|-------|------------|
| TDV234 | D62-2 | 1/8 | 2.05 |
| TDV235 | D62-3 | 3/16 | 1.48 |
| TDV398 | D62-4 | 1/4 | 1.51 |
| TDV236 | D62-5 | 5/16 | 1.87 |
| TDV399 | D62-6 | 3/8 | 2.22 |
| TDV037 | D62-7 | 7/16 | 10.70 |
| TDV237 | D62-8 | 1/2 | 4.22 |
| TDV238 | D62-10 | 5/8 | 5.15 |
| TDV239 | D62-12 | 3/4 | 10.40 |
| TDV240 | D62-14 | 7/8 | 13.30 |

COMPRESSION CONNECTORS

TUBE TO MALE PIPE

TBX716



| Model No. | Mfg. No. | Size" | Price/Each |
|-----------|----------|------------|------------|
| TBX716 | D68-2A | 1/8 x 1/8 | 1.39 |
| TBX388 | D68-3A | 3/16 x 1/8 | 1.21 |
| TBX389 | D68-3B | 3/16 x 1/4 | 2.43 |
| TBX717 | D68-4A | 1/4 x 1/8 | 1.24 |
| TBX718 | D68-4B | 1/4 x 1/4 | 1.51 |
| TBX719 | D68-4C | 1/4 x 3/8 | 2.56 |
| TBX720 | D68-4D | 1/4 x 1/2 | 4.09 |
| TBX390 | D68-5A | 5/16 x 1/8 | 2.24 |
| TBX391 | D68-5B | 5/16 x 1/4 | 1.78 |
| TBX392 | D68-5C | 5/16 x 3/8 | 7.77 |
| TBX393 | D68-5D | 5/16 x 1/2 | 19.70 |
| TBX721 | D68-6A | 3/8 x 1/8 | 2.05 |
| TBX722 | D68-6B | 3/8 x 1/4 | 1.73 |
| TBX723 | D68-6C | 3/8 x 3/8 | 2.20 |
| TBX724 | D68-6D | 3/8 x 1/2 | 2.93 |
| TBX725 | D68-6E | 3/8 x 3/4 | 10.00 |
| TBX170 | D68-7A | 7/16 x 1/8 | 8.91 |

COMPRESSION CONNECTORS

TUBE TO FEMALE PIPE

TBX697



| Model No. | Mfg. No. | Size" | Price/Each |
|-----------|----------|------------|------------|
| TBX697 | D66-2A | 1/8 x 1/8 | 2.07 |
| TBX383 | D66-3A | 3/16 x 1/8 | 1.96 |
| TBX384 | D66-3B | 3/16 x 1/4 | 2.35 |
| TBX698 | D66-4A | 1/4 x 1/8 | 1.53 |
| TBY240 | D66-4B | 1/4 x 1/4 | 2.30 |
| TBX699 | D66-4C | 1/4 x 3/8 | 5.75 |
| TBX700 | D66-4D | 1/4 x 1/2 | 6.44 |
| TBX385 | D66-5A | 5/16 x 1/8 | 3.68 |
| TBX386 | D66-5B | 5/16 x 1/4 | 3.36 |
| TBX387 | D66-5C | 5/16 x 3/8 | 5.75 |
| TBX701 | D66-6A | 3/8 x 1/8 | 2.93 |
| TBX702 | D66-6B | 3/8 x 1/4 | 2.15 |
| TBX703 | D66-6C | 3/8 x 3/8 | 2.63 |
| TBX704 | D66-6D | 3/8 x 1/2 | 3.53 |
| TBX705 | D66-6E | 3/8 x 3/4 | 13.90 |
| TBX706 | D66-8B | 1/2 x 1/4 | 17.20 |
| TBX707 | D66-8C | 1/2 x 3/8 | 3.92 |
| TBX708 | D66-8D | 1/2 x 1/2 | 4.56 |
| TBX709 | D66-8E | 1/2 x 3/4 | 13.80 |
| TBX710 | D66-10C | 5/8 x 3/8 | 10.70 |

FITTINGS, COUPLERS & VALVES



FLARE ELBOWS 45° FORGED

TUBE TO MALE PIPE

TBV328



SAE 45° FLARE FITTINGS

| Model No. | Mfg. No. | Size" | Price/Each |
|-----------|----------|------------|------------|
| TBV328 | DF54-4A | 1/4 x 1/8 | 3.40 |
| TBV329 | DF54-4B | 1/4 x 1/4 | 8.79 |
| TBV330 | DF54-4C | 1/4 x 3/8 | 7.60 |
| TBV187 | DF54-5A | 5/16 x 1/8 | 10.40 |
| TBV188 | DF54-5B | 5/16 x 1/4 | 10.80 |
| TBV331 | DF54-6B | 3/8 x 1/4 | 4.26 |
| TBV332 | DF54-6C | 3/8 x 3/8 | 5.40 |
| TBV333 | DF54-6D | 3/8 x 1/2 | 9.86 |

FLARE NUT FORGED SHORT STANDARD

TBY443



SAE 45° FLARE FITTINGS

| Model No. | Mfg. No. | Size" | Price/Each |
|-----------|----------|------------|------------|
| TBY443 | D40-3 | 3/16 | 4.89 |
| TBY733 | D40-4 | 1/4 | 1.15 |
| TBX373 | D40-4-3 | 1/4 x 3/16 | 5.94 |
| TBY444 | D40-5 | 5/16 | 2.58 |
| TBX374 | D40-5-4 | 5/16 x 1/4 | 13.30 |
| TBY734 | D40-6 | 3/8 | 1.48 |
| TBX674 | D40-6-4 | 3/8 x 1/4 | 3.04 |
| TBX375 | D40-6-5 | 3/8 x 5/16 | 5.99 |

FLARE COPPER GASKETS

TBZ627



SAE 45° FLARE FITTINGS

| Model No. | Mfg. No. | Size" | Price/Each |
|-----------|----------|-------|------------|
| TBZ627 | D59-3 | 3/16 | 2.54 |
| TBZ797 | D59-4 | 1/4 | 0.31 |
| TBZ628 | D59-5 | 5/16 | 1.75 |
| TBZ798 | D59-6 | 3/8 | 2.07 |

FLARE ELBOWS 90° FORGED

TUBE TO MALE PIPE

TBV290



SAE 45° FLARE FITTINGS

| Model No. | Mfg. No. | Size" | Price/Each |
|-----------|----------|------------|------------|
| TBV290 | DF49-2A | 1/8 x 1/8 | 8.79 |
| TBV179 | DF49-3A | 3/16 x 1/8 | 5.40 |
| TBV180 | DF49-3B | 3/16 x 1/4 | 10.00 |
| TBV291 | DF49-4A | 1/4 x 1/8 | 2.07 |
| TBV292 | DF49-4B | 1/4 x 1/4 | 2.48 |
| TBV293 | DF49-4C | 1/4 x 3/8 | 6.98 |
| TBV294 | DF49-4D | 1/4 x 1/2 | 10.10 |
| TBV181 | DF49-5A | 5/16 x 1/8 | 5.30 |
| TBV182 | DF49-5B | 5/16 x 1/4 | 4.22 |
| TBV183 | DF49-5C | 5/16 x 3/8 | 12.40 |
| TBV295 | DF49-6A | 3/8 x 1/8 | 4.09 |
| TBV296 | DF49-6B | 3/8 x 1/4 | 3.10 |
| TBV297 | DF49-6C | 3/8 x 3/8 | 3.06 |
| TBV298 | DF49-6D | 3/8 x 1/2 | 4.89 |
| TBV299 | DF49-6E | 3/8 x 3/4 | 9.67 |

FLARE ELBOWS 90° FORGED

TUBE TO TUBE

TBU852



SAE 45° FLARE FITTINGS

| Model No. | Mfg. No. | Size" | Price/Each |
|-----------|----------|-----------|------------|
| TBU852 | DF55-3 | 3/16 | 6.98 |
| TBU921 | DF55-4 | 1/4 | 3.25 |
| TBU853 | DF55-5 | 5/16 | 4.67 |
| TBU922 | DF55-6 | 3/8 | 3.66 |
| TBU594 | DF55-6-4 | 3/8 x 1/4 | 9.86 |



KLETON

Canada's Leading Material Handling Supplier



FITTINGS, COUPLERS & VALVES

ELBOWS 90°

Class 150 Malleable
Iron Pipe Fittings



TBY636

| Size" | Model No. | Mfg. No. | Price/Each |
|-------------|-----------|-----------|------------|
| 1/8 | TBY636 | DBM100-A | 1.39 |
| 1/4 | TBY637 | DBM100-B | 1.37 |
| 1/4 x 1/8 | TBU887 | DBM100-BA | 1.74 |
| 3/8 | TBY986 | DBM100-C | 1.37 |
| 3/8 x 1/4 | TBV219 | DBM100-CB | 1.72 |
| 1/2 | TBY987 | DBM100-D | 1.11 |
| 1/2 x 1/4 | TBV220 | DBM100-DB | 1.58 |
| 1/2 x 3/8 | TBV221 | DBM100-DC | 1.58 |
| 3/4 | TBY988 | DBM100-E | 1.60 |
| 3/4 x 3/8 | TBV222 | DBM100-EC | 2.00 |
| 3/4 x 1/2 | TBV223 | DBM100-ED | 2.00 |
| 1 | TBZ410 | DBM100-F | 2.38 |
| 1 x 1/2 | TBV478 | DBM100-FD | 2.93 |
| 1 x 3/4 | TBV479 | DBM100-FE | 2.93 |
| 1 1/4 | TBY328 | DBM100-G | 3.69 |
| 1 1/4 x 1/2 | TBU946 | DBM100-GD | 4.74 |

STREET ELBOWS 90°

Class 150 Malleable
Iron Pipe Fittings



TBX040

| Size" | Model No. | Mfg. No. | Price/Each |
|-------|-----------|----------|------------|
| 1/8 | TBX040 | DBM116-A | 1.58 |
| 1/4 | TBX041 | DBM116-B | 1.58 |
| 3/8 | TBX042 | DBM116-C | 1.58 |
| 1/2 | TBX043 | DBM116-D | 1.28 |
| 3/4 | TBX044 | DBM116-E | 1.90 |
| 1 | TBX586 | DBM116-F | 2.60 |
| 1 1/4 | TBV737 | DBM116-G | 5.05 |
| 1 1/2 | MLM511 | DBM116-H | 5.51 |
| 2 | MLM480 | DBM116-I | 8.47 |

HEX BUSHINGS

Class 150 Malleable
Iron Pipe Fittings



TBX021

| Size" | Model No. | Mfg. No. | Price/Each |
|-------------|-----------|-----------|------------|
| 1/4 x 1/8 | TBX021 | DBM110-BA | 1.67 |
| 3/8 x 1/8 | TBX022 | DBM110-CA | 1.25 |
| 3/8 x 1/4 | TBX023 | DBM110-CB | 1.23 |
| 1/2 x 1/8 | TBX024 | DBM110-DA | 1.02 |
| 1/2 x 1/4 | TBX025 | DBM110-DB | 1.02 |
| 1/2 x 3/8 | TBX026 | DBM110-DC | 1.00 |
| 3/4 x 1/8 | TBX027 | DBM110-EA | 1.18 |
| 3/4 x 1/4 | TBX028 | DBM110-EB | 1.18 |
| 3/4 x 3/8 | MLM709 | DBM110-EC | 1.18 |
| 3/4 x 1/2 | TBX030 | DBM110-ED | 1.16 |
| 1 x 1/4 | TBX580 | DBM110-FB | 1.67 |
| 1 x 3/8 | MLM666 | DBM110-FC | 1.67 |
| 1 x 1/2 | TBX582 | DBM110-FD | 1.67 |
| 1 x 3/4 | MLM667 | DBM110-FE | 1.67 |
| 1 1/4 x 1/4 | TBV729 | DBM110-GB | 2.56 |
| 1 1/4 x 3/8 | TBV730 | DBM110-GC | 2.56 |

FLOOR FLANGES

Class 150 Malleable
Iron Pipe Fittings



TBX918

| Size" | Model No. | Mfg. No. | Price/Each |
|-------|-----------|----------|------------|
| 1/4 | TBX918 | DBMFF-B | 3.96 |
| 3/8 | TBX919 | DBMFF-C | 3.62 |
| 1/2 | TBX920 | DBMFF-D | 3.34 |
| 3/4 | TBX921 | DBMFF-E | 4.67 |
| 1 | TBY369 | DBMFF-F | 5.63 |
| 1 1/4 | TBX304 | DBMFF-G | 8.20 |
| 1 1/2 | TBX305 | DBMFF-H | 9.61 |
| 2 | TBY370 | DBMFF-I | 10.90 |

CLOSE NIPPLES

Black Iron



TDV902

| Size" | Model No. | Mfg. No. | Price/Each |
|---------------|-----------|----------|------------|
| 1/8 x CLOSE | TDV902 | DBM112-A | 1.44 |
| 1/4 x CLOSE | TDV903 | DBM112-B | 1.30 |
| 3/8 x CLOSE | TBX899 | DBM112-C | 1.46 |
| 1/2 x CLOSE | TBX900 | DBM112-D | 0.88 |
| 3/4 x CLOSE | TBX901 | DBM112-E | 1.05 |
| 1 x CLOSE | TBY339 | DBM112-F | 1.63 |
| 1 1/4 x CLOSE | TBX290 | DBM112-G | 2.09 |
| 1 1/2 x CLOSE | TBX291 | DBM112-H | 2.62 |
| 2 x CLOSE | TBY340 | DBM112-I | 3.58 |
| 2 1/2 x CLOSE | MLM520 | DBM112-J | 9.05 |
| 3 x CLOSE | TBY341 | DBM112-K | 10.20 |
| 4 x CLOSE | TBY342 | DBM112-L | 16.20 |

REDUCING COUPLINGS

Class 150 Malleable
Iron Pipe Fittings



TBV231

| Size" | Model No. | Mfg. No. | Price/Each |
|-------------|-----------|-----------|------------|
| 1/4 x 1/8 | TBV231 | DBM119-BA | 1.23 |
| 3/8 x 1/8 | TBV232 | DBM119-CA | 1.23 |
| 3/8 x 1/4 | TBV233 | DBM119-CB | 1.23 |
| 1/2 x 1/8 | TBV234 | DBM119-DA | 1.18 |
| 1/2 x 1/4 | TBV235 | DBM119-DB | 1.18 |
| 1/2 x 3/8 | TBV236 | DBM119-DC | 1.18 |
| 3/4 x 1/4 | TBV237 | DBM119-EB | 1.60 |
| 3/4 x 3/8 | TBV238 | DBM119-EC | 1.60 |
| 3/4 x 1/2 | TBV239 | DBM119-ED | 1.58 |
| 1 x 1/4 | TBV485 | DBM119-FB | 2.07 |
| 1 x 3/8 | TBV486 | DBM119-FC | 2.07 |
| 1 x 1/2 | TBV487 | DBM119-FD | 2.07 |
| 1 x 3/4 | TBV488 | DBM119-FE | 2.05 |
| 1 1/4 x 1/2 | TBU953 | DBM119-GD | 3.00 |
| 1 1/4 x 3/4 | TBU954 | DBM119-GE | 3.00 |
| 1 1/4 x 1 | TBV240 | DBM119-GF | 3.00 |
| 1 1/2 x 1/2 | TBU955 | DBM119-HD | 3.89 |
| 1 1/2 x 3/4 | TBU956 | DBM119-HE | 3.89 |
| 1 1/2 x 1 | TBV241 | DBM119-HF | 3.89 |

FITTINGS, COUPLERS & VALVES

TEES

Class 150 Malleable
Iron Pipe Fittings



| Size" | Model No. | Mfg. No. | Price/Each |
|-------|-----------|----------|------------|
| 1/8 | TDV166 | DBM101-A | 1.81 |
| 1/4 | MLB513 | DBM101-B | 1.79 |
| 3/8 | MLB514 | DBM101-C | 1.79 |
| 1/2 | MLB546 | DBM101-D | 1.46 |
| 3/4 | MLB472 | DBM101-E | 2.00 |
| 1 | MLB371 | DBM101-F | 3.18 |
| 1 1/4 | TBZ720 | DBM101-G | 4.94 |

UNIONS

Class 150 Malleable
Iron Pipe Fittings



| Size" | Model No. | Mfg. No. | Price/Each |
|---------|-----------|-----------|------------|
| 1/8 | TBZ727 | DBM104-A | 7.00 |
| 1/4 | TBZ728 | DBM104-B | 6.11 |
| 3/8 | TBZ729 | DBM104-C | 6.09 |
| 1/2 | TBZ730 | DBM104-D | 5.25 |
| 3/4 | TBZ731 | DBM104-E | 6.36 |
| 1 | TDV173 | DBM104-F | 8.25 |
| 1 x 1/2 | TBY088 | DBM104-FD | 8.58 |
| 1 x 1/2 | TBY089 | DBM104-FE | 8.58 |
| 1 1/4 | TBZ183 | DBM104-G | 10.10 |
| 1 1/2 | TBZ184 | DBM104-H | 13.30 |

REDUCING ELBOWS 90°

Galvanized



| Size" | Model No. | Mfg. No. | Price/Each |
|-----------|-----------|------------|------------|
| 1/2 x 3/8 | TLY067 | DBMG100-DC | 1.95 |
| 3/4 x 1/2 | TLY069 | DBMG100-ED | 2.45 |
| 1 x 1/2 | TLY072 | DBMG100-FD | 3.74 |
| 1 x 3/4 | TLY073 | DBMG100-FE | 3.74 |

COUPLINGS

Class 150 Malleable
Iron Pipe Fittings



| Size" | Model No. | Mfg. No. | Price/Each |
|-------|-----------|----------|------------|
| 1/8 | TBY989 | DBM103-A | 1.09 |
| 1/4 | TBY990 | DBM103-B | 1.09 |
| 3/8 | TBY991 | DBM103-C | 1.09 |
| 1/2 | TBY992 | DBM103-D | 0.93 |
| 3/4 | TBY993 | DBM103-E | 1.23 |
| 1 | TBZ414 | DBM103-F | 1.95 |

LONG NIPPLES



| Size" | Black Iron | | | Galvanized | | |
|-------------|------------|---------------|------------|------------|---------------|------------|
| | Model No. | Mfg. No. | Price/Each | Model No. | Mfg. No. | Price/Each |
| 1/8 x 1 1/2 | TLZ943 | DBM113-A1 1/2 | 1.58 | - | - | - |
| 1/8 x 2 | TLZ947 | DBM113-A2 | 1.63 | - | - | - |
| 1/8 x 2 1/2 | TLZ948 | DBM113-A2 1/2 | 1.90 | - | - | - |
| 1/8 x 3 | TLZ949 | DBM113-A3 | 1.97 | - | - | - |
| 1/8 x 3 1/2 | TLZ950 | DBM113-A3 1/2 | 2.18 | - | - | - |
| 1/8 x 4 | TDX191 | DBM113-A4 | 2.27 | - | - | - |
| 1/8 x 4 1/2 | TLZ951 | DBM113-A4 1/2 | 2.78 | - | - | - |
| 1/8 x 5 | TDX192 | DBM113-A5 | 3.02 | - | - | - |
| 1/8 x 5 1/2 | TLZ952 | DBM113-A5 1/2 | 3.36 | - | - | - |
| 1/8 x 6 | TDX193 | DBM113-A6 | 3.76 | - | - | - |
| 1/8 x 7 | TLZ953 | DBM113-A7 | 6.29 | - | - | - |
| 1/8 x 8 | TLZ954 | DBM113-A8 | 6.71 | - | - | - |
| 1/8 x 9 | TLZ955 | DBM113-A9 | 6.98 | - | - | - |
| 1/8 x 10 | TLZ944 | DBM113-A10 | 7.45 | - | - | - |
| 1/8 x 11 | TLZ945 | DBM113-A11 | 7.56 | - | - | - |
| 1/8 x 12 | TLZ946 | DBM113-A12 | 8.18 | - | - | - |
| 1/4 x 1 1/2 | TLZ956 | DBM113-B1 1/2 | 1.39 | - | - | - |
| 1/4 x 2 | TDX194 | DBM113-B2 | 1.46 | - | - | - |
| 1/4 x 2 1/2 | TLZ960 | DBM113-B2 1/2 | 1.83 | - | - | - |
| 1/4 x 3 | TDX195 | DBM113-B3 | 1.76 | - | - | - |
| 1/4 x 3 1/2 | TLZ961 | DBM113-B3 1/2 | 2.25 | - | - | - |
| 1/4 x 4 | TDX196 | DBM113-B4 | 2.27 | - | - | - |
| 1/4 x 4 1/2 | TLZ962 | DBM113-B4 1/2 | 2.89 | - | - | - |
| 1/4 x 5 | TDX197 | DBM113-B5 | 3.47 | - | - | - |
| 1/4 x 5 1/2 | TLZ963 | DBM113-B5 1/2 | 3.89 | - | - | - |
| 1/4 x 6 | TDX198 | DBM113-B6 | 3.65 | - | - | - |
| 1/4 x 7 | TLZ964 | DBM113-B7 | 6.51 | - | - | - |
| 1/4 x 8 | TLZ965 | DBM113-B8 | 6.67 | - | - | - |
| 1/4 x 9 | TLZ966 | DBM113-B9 | 7.20 | - | - | - |
| 1/4 x 10 | TLZ957 | DBM113-B10 | 6.85 | - | - | - |
| 1/4 x 11 | TLZ958 | DBM113-B11 | 8.00 | - | - | - |
| 1/4 x 12 | TLZ959 | DBM113-B12 | 8.20 | - | - | - |
| 3/8 x 1 1/2 | TLZ967 | DBM113-C1 1/2 | 1.63 | - | - | - |
| 3/8 x 2 | TBZ002 | DBM113-C2 | 1.72 | - | - | - |
| 3/8 x 2 1/2 | TLZ971 | DBM113-C2 1/2 | 2.00 | - | - | - |
| 3/8 x 3 | TBZ003 | DBM113-C3 | 2.07 | - | - | - |
| 3/8 x 3 1/2 | TLZ972 | DBM113-C3 1/2 | 2.36 | - | - | - |
| 3/8 x 4 | TBZ004 | DBM113-C4 | 2.56 | - | - | - |
| 3/8 x 5 | TBZ005 | DBM113-C5 | 3.47 | - | - | - |
| 3/8 x 5 1/2 | TLZ974 | DBM113-C5 1/2 | 3.76 | - | - | - |
| 3/8 x 6 | TBZ006 | DBM113-C6 | 4.22 | - | - | - |
| 3/8 x 8 | TLZ975 | DBM113-C8 | 6.51 | - | - | - |
| 3/8 x 10 | TLZ968 | DBM113-C10 | 7.45 | - | - | - |
| 3/8 x 11 | TLZ969 | DBM113-C11 | 8.87 | - | - | - |
| 3/8 x 12 | TLZ970 | DBM113-C12 | 9.20 | - | - | - |
| 1/2 x 1 1/2 | TLZ976 | DBM113-D1 1/2 | 0.98 | TLY105 | DBMG113-D11/2 | 1.05 |
| 1/2 x 2 | TBZ007 | DBM113-D2 | 1.09 | TLY106 | DBMG113-D2 | 1.23 |
| 1/2 x 2 1/2 | TLZ980 | DBM113-D2 1/2 | 1.28 | TLY107 | DBMG113-D21/2 | 1.37 |
| 1/2 x 3 | TBZ008 | DBM113-D3 | 1.35 | TLY108 | DBMG113-D3 | 1.65 |

CROSSES

Class 150 Malleable
Iron Pipe Fittings



| Size" | Model No. | Mfg. No. | Price/Each |
|-------|-----------|----------|------------|
| 1/4 | TBZ723 | DBM102-B | 4.02 |
| 3/8 | TBZ724 | DBM102-C | 4.14 |
| 1/2 | TBZ725 | DBM102-D | 3.62 |

See pages 1372 - 1373
for a full offering of
pipe and chain wrenches



TOPRING

SERIES & SIZES

To determine correct series place plug directly on page. Reference only, slight difference may occur in printing

INDUSTRIAL (MIL-C-4109)
ISO 6150-B-12/15/17
PARKER 20/30
HANSEN 3000/4000/5000

$\frac{I/M}{1/4''}$

$\frac{I/M}{3/8''}$

$\frac{I/M}{1/2''}$

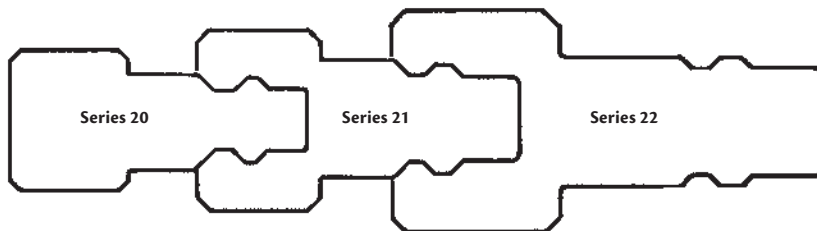

ARO 210
PARKER 50
DILL

$\frac{A}{1/4''}$



AUTOMOTIVE
TRUFLATE
CP

PARKER 10
AMFLO
DILL

$\frac{T}{1/4''}$

$\frac{T}{3/8''}$

$\frac{T}{1/2''}$

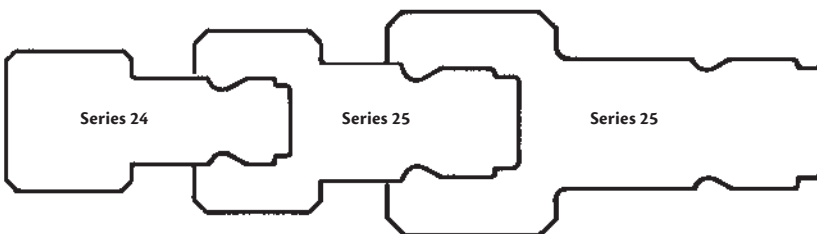

LINCOLN

$\frac{L}{1/4''}$

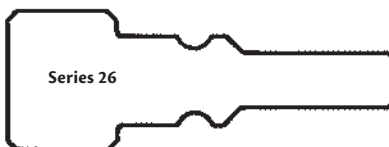

STÄUBLI
ISO-6150-C

$\frac{S}{1/4''}$

$\frac{S}{3/8''}$

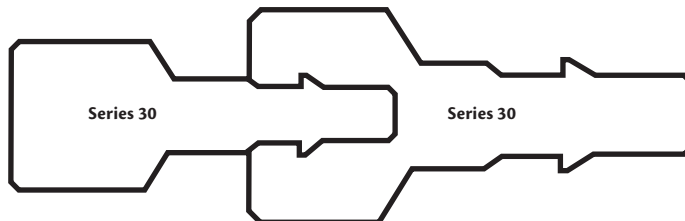

EUROPEAN 7.8 MM/10.4 MM
CEJN 320/410

$\frac{E}{7.8}$

$\frac{E}{10.4}$



FITTINGS, COUPLERS & VALVES

QUICK COUPLERS

High performance, corrosion resistant quick couplers built to interchange with industrial type couplings. Offer a higher flow for maximum on-line performance of hand-held air tools. Heavy-duty, high quality design.



TOPRING

1/4 INDUSTRIAL INTERCHANGE

1/4 INDUSTRIAL PLUGS

- Zinc Plated or Stainless Steel 304
- Corrosion resistant

1/4 INDUSTRIAL AUTOMAX COUPLERS

- Automatic push-to-connect operation
- Proven and positive connection using pin-lock mechanism
- Max 250 PSI
- 37 SCFM

1/4 INDUSTRIAL MAXQUIK COUPLERS

- Manual operation
- Sleeve guard prevents accidental disconnection
- Max 250 PSI
- 24 SCFM

| Size | Model No. | Mfg. No. | Price/Each | Size | Model No. | Mfg. No. | Price/Each | Size | Model No. | Mfg. No. | Price/Each |
|------------------------------|-----------|----------|------------|------------------------|-----------|----------|------------|------------------------|-----------|----------|------------|
| FEMALE THREAD (F) NPT | | | | | | | | | | | |
| 1/8 | TA243 | 20.122 | 2.93 | 1/8 | - | - | - | 1/8 | - | - | - |
| 1/4 | TA244 | 20.142 | 1.94 | 1/4 | TZ184 | 20.444 | 10.90 | 1/4 | TA268 | 20.842 | 8.74 |
| 1/4 (Stainless) | TLV344 | 20.146 | 11.90 | 1/4 (Stainless) | - | - | - | 1/4 (Stainless) | - | - | - |
| 3/8 | TA245 | 20.162 | 4.06 | 3/8 | - | - | - | 3/8 | TA269 | 20.862 | 12.10 |
| MALE THREAD (M) NPT | | | | | | | | | | | |
| 1/8 | TA247 | 20.222 | 2.56 | 1/8 | - | - | - | 1/8 | - | - | - |
| 1/4 | TA248 | 20.242 | 1.94 | 1/4 | TZ185 | 20.644 | 11.10 | 1/4 | TA271 | 20.942 | 8.74 |
| 1/4 (w/thread sealant) | TLV345 | 20.248 | 2.14 | 1/4 (w/thread sealant) | - | - | - | 1/4 (w/thread sealant) | - | - | - |
| 1/4 (Stainless) | TLV346 | 20.246 | 10.60 | 1/4 (Stainless) | - | - | - | 1/4 (Stainless) | TLV348 | 20.946 | 40.50 |
| 3/8 | TA249 | 20.262 | 2.91 | 3/8 | TZ227 | 20.664 | 13.70 | 3/8 | TA272 | 20.962 | 11.40 |
| HOSE BARB | | | | | | | | | | | |
| 1/4 I.D. | TA252 | 20.342 | 3.55 | 1/4 I.D. | TZ228 | 20.744 | 14.30 | 1/4 I.D. | TA258 | 20.542 | 12.90 |
| 5/16 I.D. | TA253 | 20.352 | 5.17 | 5/16 I.D. | - | - | - | 5/16 I.D. | - | - | - |
| 3/8 I.D. | TA254 | 20.362 | 3.55 | 3/8 I.D. | TZ230 | 20.764 | 14.70 | 3/8 I.D. | TA260 | 20.562 | 13.50 |

3/8 INDUSTRIAL INTERCHANGE

3/8 INDUSTRIAL PLUGS

- Hardened Steel construction
- Corrosion resistant

3/8 INDUSTRIAL AUTOMAX COUPLERS

- Automatic push-to-connect operation
- Proven and positive connection using pin-lock mechanism
- Max 250 PSI
- 62 SCFM

3/8 INDUSTRIAL MAXQUIK COUPLERS

- Manual operation
- Sleeve guard prevents accidental disconnection
- Max 250 PSI
- 67 SCFM

| Size | Model No. | Mfg. No. | Price/Each | Size | Model No. | Mfg. No. | Price/Each | Size | Model No. | Mfg. No. | Price/Each |
|------------------------------|-----------|----------|------------|----------|-----------|----------|------------|----------|-----------|----------|------------|
| FEMALE THREAD (F) NPT | | | | | | | | | | | |
| 1/4 | TA273 | 21.142 | 4.17 | 1/4 | TA281 | 21.442 | 28.60 | 1/4 | TZ144 | 21.842 | 23.30 |
| 3/8 | TA274 | 21.162 | 4.46 | 3/8 | TA282 | 21.462 | 29.20 | 3/8 | TZ145 | 21.862 | 23.30 |
| 1/2 | TZ132 | 21.182 | 7.55 | 1/2 | TZ137 | 21.482 | 30.90 | 1/2 | TZ146 | 21.882 | 26.10 |
| MALE THREAD (M) NPT | | | | | | | | | | | |
| 1/4 | TA278 | 21.242 | 4.01 | 1/4 | TZ138 | 21.642 | 31.30 | 1/4 | TZ147 | 21.942 | 23.30 |
| 3/8 | TA279 | 21.262 | 4.23 | 3/8 | TA283 | 21.662 | 31.20 | 3/8 | TZ148 | 21.962 | 23.30 |
| 1/2 | TZ133 | 21.282 | 7.87 | 1/2 | TZ139 | 21.682 | 32.10 | 1/2 | TZ149 | 21.982 | 26.10 |
| HOSE BARB | | | | | | | | | | | |
| 1/4 I.D. | TZ134 | 21.342 | 6.33 | 1/4 I.D. | - | - | - | 1/4 I.D. | - | - | - |
| 3/8 I.D. | TA280 | 21.362 | 6.14 | 3/8 I.D. | TZ142 | 21.762 | 33.80 | 3/8 I.D. | TZ152 | 21.562 | 27.20 |
| 1/2 I.D. | TZ136 | 21.282 | 7.49 | 1/2 I.D. | TZ143 | 21.782 | 34.40 | 1/2 I.D. | TZ153 | 21.582 | 27.20 |

1/2 INDUSTRIAL INTERCHANGE

1/2 INDUSTRIAL PLUGS

- Hardened Steel construction
- Corrosion resistant

1/2 INDUSTRIAL AUTOMAX COUPLERS

- Automatic push-to-connect operation
- Proven and positive connection using pin-lock mechanism
- Max 250 PSI
- 99 SCFM

3/8 INDUSTRIAL MAXQUIK COUPLERS

- Manual operation
- Sleeve guard prevents accidental disconnection
- Max 250 PSI
- 99 SCFM

| Size | Model No. | Mfg. No. | Price/Each | Size | Model No. | Mfg. No. | Price/Each | Size | Model No. | Mfg. No. | Price/Each |
|------------------------------|-----------|----------|------------|----------|-----------|----------|------------|----------|-----------|----------|------------|
| FEMALE THREAD (F) NPT | | | | | | | | | | | |
| 3/8 | TZ154 | 22.162 | 7.05 | 3/8 | - | - | - | 3/8 | - | - | - |
| 1/2 | TZ155 | 22.182 | 7.40 | 1/2 | TZ165 | 22.482 | 37.30 | 1/2 | TZ175 | 22.882 | 30.60 |
| 3/4 | TZ156 | 22.192 | 12.30 | 3/4 | - | - | - | 3/4 | TZ176 | 22.892 | 31.40 |
| MALE THREAD (M) NPT | | | | | | | | | | | |
| 3/8 | TZ158 | 22.262 | 6.02 | 3/8 | - | - | - | 3/8 | - | - | - |
| 1/2 | TZ159 | 22.282 | 6.94 | 1/2 | TZ169 | 22.682 | 37.40 | 1/2 | TZ179 | 22.982 | 29.90 |
| 3/4 | TZ160 | 22.292 | 12.50 | 3/4 | - | - | - | 3/4 | TZ180 | 22.992 | 29.90 |
| HOSE BARB | | | | | | | | | | | |
| 3/8 I.D. | TZ161 | 22.362 | 6.91 | 3/8 I.D. | - | - | - | 3/8 I.D. | - | - | - |
| 1/2 I.D. | TZ162 | 22.382 | 9.61 | 1/2 I.D. | TZ172 | 22.782 | 51.10 | 1/2 I.D. | TZ182 | 22.582 | 31.80 |

FITTINGS

HOSE BARB SPLICERS



| Model No. | Hose I.D." | Price/Each |
|-----------|------------|------------|
| TA492 | 1/4 | 1.28 |
| TA493 | 5/16 | 1.56 |
| TA494 | 3/8 | 1.53 |
| TA495 | 1/2 | 3.14 |
| TA496 | 5/8 | 3.97 |
| TA497 | 3/4 | 5.58 |

HOSE BARB TO FEMALE PIPE CONNECTORS



| Model No. | Hose I.D." | Thread (F) NPT | Price /Each |
|-----------|------------|----------------|-------------|
| TZ072 | 1/4 | 1/8 | 2.09 |
| TA502 | 1/4 | 1/4 | 2.22 |
| TZ073 | 5/16 | 1/4 | 3.52 |
| TA503 | 3/8 | 1/4 | 2.44 |
| TA504 | 3/8 | 3/8 | 3.48 |
| TA505 | 1/2 | 1/2 | 5.33 |

HOSE BARB COUPLERS TO FEMALE BALL END



| Model No. | Hose I.D." | Thread (F) NPT | Price /Each |
|-----------|------------|----------------|-------------|
| TZ098 | 1/4 | 1/4 | 4.36 |
| TZ100 | 5/16 | 1/4 | 4.60 |
| TZ101 | 3/8 | 1/4 | 4.60 |
| TZ102 | 3/8 | 3/8 | 5.40 |

HOSE BARB COUPLERS FLAT SEAT WITH GASKET



| Model No. | Hose I.D." | Thread (F) NPT | Price /Each |
|-----------|------------|----------------|-------------|
| TZ105 | 1/4 | 1/4 | 5.21 |
| TZ106 | 5/16 | 1/4 | 6.17 |
| TZ107 | 3/8 | 1/4 | 6.17 |
| TZ108 | 3/8 | 3/8 | 7.44 |
| TZ109 | 1/2 | 1/2 | 10.60 |

TOPRING

HOSE BARB TO MALE PIPES



| Model No. | Hose I.D." | Thread (M) NPT | Price /Each |
|-----------|------------|----------------|-------------|
| TZ075 | 1/8 | 1/8 | 1.47 |
| TZ076 | 3/16 | 1/8 | 1.47 |
| TA498 | 1/4 | 1/8 | 1.47 |
| TA499 | 1/4 | 1/4 | 1.56 |
| TZ077* | 1/4 | 1/4 | 6.12 |
| TZ078 | 1/4 | 3/8 | 2.44 |
| TZ079 | 5/8 | 3/8 | 3.28 |
| TZ080 | 5/8 | 1/2 | 4.28 |
| TZ081 | 5/8 | 3/4 | 6.33 |
| TZ083 | 5/16 | 1/4 | 1.90 |
| TZ084 | 3/8 | 1/8 | 1.66 |
| TA500 | 3/8 | 1/4 | 1.71 |
| TZ085* | 3/8 | 1/4 | 6.71 |
| TA501 | 3/8 | 3/8 | 2.26 |
| TZ086* | 3/8 | 3/8 | 8.52 |
| TZ087 | 3/8 | 1/2 | 3.86 |
| TZ088 | 1/2 | 1/4 | 2.37 |
| TZ089 | 1/2 | 3/8 | 2.95 |
| TZ090 | 1/2 | 1/2 | 3.40 |
| TZ091* | 1/2 | 1/2 | 10.90 |
| TZ092 | 1/2 | 3/4 | 6.36 |
| TZ093 | 3/4 | 1/2 | 4.55 |
| TZ094 | 3/4 | 3/4 | 5.36 |
| TZ095 | 1 | 3/4 | 7.40 |
| TZ096 | 1 | 1 | 11.30 |

*Swivel

REUSABLE HOSE FITTINGS



| Model No. | Hose O.D." | Hose I.D." | Thread (M) NPT | Price /Each |
|-----------|------------|------------|----------------|-------------|
| TZ110 | 1/2 | 1/4 | 1/4 | 15.20 |
| TZ111 | 9/16 | 1/4 | 1/4 | 15.70 |
| TZ112 | 5/8 | 1/4 | 1/4 | 15.90 |
| TZ115 | 9/16 | 5/16 | 1/4 | 19.90 |
| TZ119 | 5/8 | 3/8 | 1/4 | 17.10 |
| TZ120 | 5/8 | 3/8 | 3/8 | 17.60 |
| TZ121 | 11/16 | 3/8 | 1/4 | 17.60 |
| TZ123 | 3/4 | 3/8 | 1/4 | 18.20 |
| TZ128 | 7/8 | 1/2 | 1/2 | 33.90 |

UNIMAX 5-IN-1 UNIVERSAL COUPLERS

UNIVERSAL INTERCHANGE ACCEPTS:

- Ultraflo
- ARO 210
- Lincoln
- 1/4 Industrial
- 1/4 Truflate
- Automatic push-to-connect operation
- Sleeve guard protects against accidental disconnection when the coupler is dragged on the floor or over obstructions
- Deep knurled socket sleeve for positive gripping



TOPRING

| Model No. | Mfg. No. | NPT | Price/Each |
|----------------------|----------|-----|------------|
| FEMALE THREAD | | | |
| TKZ830 | 20.441 | 1/4 | 20.70 |
| MALE THREAD | | | |
| TKZ831 | 20.641 | 1/4 | 22.30 |

See pages 30 - 37 for Small Parts Containers



UNISAFE UNIVERSAL 5-IN-1 INTERCHANGE SAFETY COUPLERS

UNIVERSAL INTERCHANGE ACCEPTS:

- Ultraflo
- ARO 210
- Lincoln
- 1/4 Industrial
- 1/4 Truflate
- Valve sleeve is operated independently of locking sleeve
- When the valve sleeve is moved to shut off air flow downstream pressure is automatically vented
- Disconnection and connection are performed easily at zero pressure
- Automatic push-to-connect operation

1/4"

| Model No. | Mfg. No. | NPT | Price/Each |
|----------------------|----------|-----|------------|
| FEMALE THREAD | | | |
| TGA093 | 20.448 | 1/4 | 27.30 |
| MALE THREAD | | | |
| TGA098 | 20.648 | 1/4 | 29.30 |

TOPRING

ARO 210 Type

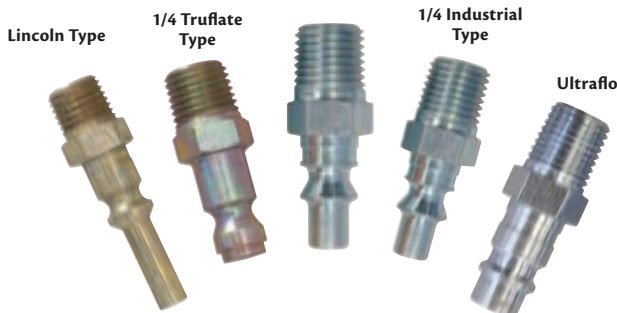

SAFETY COMES FROM 2-STEP DISCONNECTION:

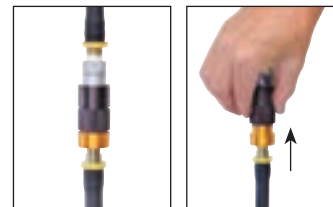

Male/female connected set

Slide the black sleeve to release downstream pressure

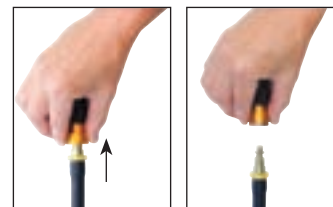

Slide the gold sleeve to release plug

Disconnection



FITTINGS, COUPLERS & VALVES

TOPQUIK INDUSTRIAL SAFETY COUPLERS

- Prevents dangerous hose whip through 2-step disconnection
- Shock and crush resistant
- Non-marring body prevents scratching
- Super lightweight and ergonomic
- Maximum 225 PSI



TOPRING

3/8" COUPLER

| Model No. | Mfg. No. | NPT | Price/Each |
|----------------------|----------|-----|------------|
| FEMALE THREAD | | | |
| TLZ044 | 21.449 | 1/4 | 47.60 |
| TLZ045 | 21.469 | 3/8 | 47.10 |
| TLZ046 | 21.489 | 1/2 | 47.60 |
| MALE THREAD | | | |
| TLZ047 | 21.649 | 1/4 | 47.60 |
| TLZ048 | 21.669 | 3/8 | 51.70 |
| TLZ049 | 21.689 | 1/2 | 51.70 |

1/4" COUPLER

| Model No. | Mfg. No. | NPT | SCFM | Price/Each |
|----------------------|----------|-----|------|------------|
| FEMALE THREAD | | | | |
| TLZ040 | 20.449 | 1/4 | 36 | 30.80 |
| TLZ041 | 20.469 | 3/8 | 36 | 35.20 |
| MALE THREAD | | | | |
| TLZ042 | 20.649 | 1/4 | 36 | 37.60 |
| TLZ043 | 20.669 | 3/8 | 36 | 37.60 |

SAFETY COMES FROM 2-STEP DISCONNECTION:



- Slide the sleeve back to release downstream pressure
- The plug is released, but held within the coupler



- Slide the sleeve forward
- The plug is released completely



QUICKSILVER 1/4" INDUSTRIAL HIGH PRESSURE COUPLERS

- Delivers high air volume with low pressure drop for better tool performance
- Corrosion resistant for long service life
- Drag guard protects against accidental disconnection
- Automatic push-to-connect operation
- Maximum 500 PSI
- 44 SCFM

| Model No. | Mfg. No. | NPT | Price/Each |
|----------------------|----------|-----|------------|
| FEMALE THREAD | | | |
| BC080 | 20.446 | 1/4 | 23.10 |
| BC082 | 20.466 | 3/8 | 28.10 |
| MALE THREAD | | | |
| BC090 | 20.646 | 1/4 | 27.40 |
| BC093 | 20.666 | 3/8 | 28.80 |



BC080

TOPRING

1/4" INDUSTRIAL INTERCHANGE PLUGS

- Zinc Plated or Stainless Steel 304
- Corrosion resistant
- Made to precise standards to ensure fit

| Model No. | Mfg. No. | NPT | Price/Each |
|----------------------|----------|-----------------|------------|
| FEMALE THREAD | | | |
| TA243 | 20.122 | 1/8 | 2.93 |
| TA244 | 20.142 | 1/4 | 1.94 |
| TLV344 | 20.146 | 1/4 (stainless) | 11.90 |
| TA245 | 20.162 | 3/8 | 4.06 |
| MALE THREAD | | | |
| TA247 | 20.222 | 1/8 | 2.56 |
| TA248 | 20.242 | 1/4 | 1.94 |
| TLV345 | 20.248 | 1/4 (sealant) | 2.14 |
| TA249 | 20.262 | 3/8 | 2.91 |



TA243



TA247

TOPRING

| Model No. | Mfg. No. | I.D." | Price/Each |
|------------------|----------|-------|------------|
| HOSE BARB | | | |
| TA252 | 20.342 | 1/4 | 3.55 |
| TA253 | 20.352 | 5/16 | 5.17 |
| TA254 | 20.362 | 3/8 | 3.55 |

AUTOMAX ARO 210 INTERCHANGE COUPLERS

- Accepts ARO 210 Plugs
- Automatic push to connect operation
- Deep knurled socket sleeve
- Max PSI: 250
- 34 SCFM

TOPRING



TZ998



TS404

| Model No. | Mfg. No. | I.D." | Price/Each |
|------------------|----------|-------|------------|
| HOSE BARB | | | |
| TS404 | 23.744 | 1/4 | 14.80 |
| TS406 | 23.764 | 3/8 | 15.30 |

1/4 ARO 210 INTERCHANGE PLUGS

- Hardened steel construction
- Corrosion resistant
- Made to precise standards to ensure fit

TOPRING

| Model No. | Mfg. No. | NPT | Price/Each |
|----------------------|----------|------------------------|------------|
| FEMALE THREAD | | | |
| TA284 | 23.142 | 1/4 | 2.03 |
| MALE THREAD | | | |
| TS388 | 23.222 | 1/8 | 2.31 |
| TA285 | 23.242 | 1/4 | 2.02 |
| TLV349 | 23.248 | 1/4 (w/thread sealant) | 2.20 |



TA284



TS388

| Model No. | Mfg. No. | I.D." | Price/Each |
|------------------|----------|-------|------------|
| HOSE BARB | | | |
| TG020 | 23.342 | 1/4 | 3.55 |
| TS391 | 23.352 | 5/16 | 4.74 |
| TS392 | 23.362 | 3/8 | 3.55 |

1/4 TRUFLATE INTERCHANGE PLUGS

- Accepts 1/4 Truflate couplers
- Compact design
- Automatic push to connect design

| Model No. | Mfg. No. | NPT | Price/Each |
|--------------------|----------|-----|------------|
| MALE THREAD | | | |
| TS412 | 24.242 | 1/4 | 2.51 |



TOPRING

QUISILVER 1/4" ULTRAFLO INTERCHANGE COUPLER

- Delivers high air volume with low pressure drop for better tool performance
- Corrosion resistant for long service life
- Drag guard protects against accidental disconnection
- Automatic push-to-connect operation
- Maximum 500 PSI
- 80 SCFM
- Accepts CEJN 320 type plugs (Ultraflo)

| NPT | Model No. | Mfg. No. | Price /Each |
|----------------------|-----------|----------|-------------|
| FEMALE THREAD | | | |
| 1/4 | TS510 | 31.744 | 25.10 |
| 3/8 | TS513 | 31.764 | 26.40 |
| MALE THREAD | | | |
| 1/4 | TS514 | 31.844 | 27.50 |
| 3/8 | TS516 | 31.864 | 28.80 |



TS510

TOPRING

ULTRAFLO INTERCHANGE PLUGS

- High flow for better tool performance
- Compatible with European (CEJN 320) type couplers
- Hardened steel construction

TOPRING

| Model No. | Mfg. No. | NPT | Price/Each |
|----------------------|----------|-----|------------|
| FEMALE THREAD | | | |
| TZ213 | 31.542 | 1/4 | 3.06 |
| TS506 | 31.562 | 3/8 | 3.89 |
| MALE THREAD | | | |
| TZ214 | 31.642 | 1/4 | 2.92 |
| TS508 | 31.662 | 3/8 | 3.89 |



TZ213



TZ214

| Model No. | Mfg. No. | I.D." | Price/Each | |
|---------------------------|----------|---------|----------------|------------|
| HOSE BARB | | | | |
| TS519 | 31.962 | 3/8 | 4.32 | |
| Model No. | Mfg. No. | (M) NPT | Type | Price/Each |
| FREE ANGLE FITTING | | | | |
| TGA774 | 62.370C | 1/4 | 30° Free angle | 12.30 |

FITTINGS, COUPLERS & VALVES

MAXPRO 30° FREE ANGLE FITTINGS

- Prevents kinking and tangling of hoses
- Reduces operator fatigue by allowing better tool maneuverability
- Reduces tension put on wrist by the hose
- Free angle fittings rotate 360° and up to 30° of deflection of air tool supply line
- Max working pressure 140 PSI

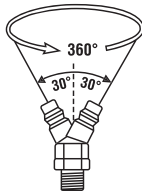

TGA772

TOPRING

| Model No | Mfg. No. | Description | Price/Each |
|----------|----------|-----------------------------------|------------|
| TGA770 | 62.350C | 1/4 (M) NPT x 1/4 (M) NPT | 12.30 |
| TGA771 | 62.355C | 1/4 (F) NPT x 1/4 (M) NPT | 12.30 |
| TGA772 | 62.360C | 1/4 industrial type x 1/4 (M) NPT | 12.30 |
| TGA773 | 62.365C | ARO 210 type x 1/4 (M) NPT | 12.30 |
| TGA774 | 62.370C | Ultraflo x 1/4 (M) NPT | 12.30 |

AIR TOOL SWIVEL CONNECTORS

- Improve tool manoeuvrability, minimizes operator's fatigue and extends hose life
- Universal-joint that connects portable air tools to an air line
- 360° Swivel at two locations which allows an air hose to drop straight to the floor, no matter how the tool is held

WARNING: Not to be used on percussion tools or in areas of high mechanical abuse

Applications

- For use with most air tools such as: Grinders - Sanders - Staple guns - Drills buffers - Spray guns - Glue guns
- Maximum working pressure: 150 PSI



TOPRING

| Model No. | Mfg. No. | Port Size NPT | Maximum Air Flow SCFM | Wt. lbs. | Price /Each |
|-----------|----------|---------------|-----------------------|----------|-------------|
| TA874 | 62.704C | 1/4 | 33 | 0.2 | 42.30 |
| TA876 | 62.708 | 1/2 | 65 | 0.8 | 193.00 |

HOSE WHIPS

- Prolong hose life by eliminating stress
- Easy tool manipulation

Application

- Used between the air tool and quick coupler to act as a "shock absorber" and to prolong the life of the coupler



TLV350

TOPRING

| Model No. | Mfg. No. | Hose I.D." | O.A. Length" | Rigid Fitting (F) NPT | Price /Each |
|-----------|----------|------------|--------------|-----------------------|-------------|
| TLV350 | 62.523 | 1/4 | 18 | 1/4 | 8.60 |
| TLV351 | 62.543 | 3/8 | 18 | 1/4 | 9.53 |

SWIVEL CONNECTORS WITH FLOW CONTROL

- Swivels 360° which allows air hose to drop straight to the floor, no matter how the tool is held
- Integrated air-flow control dial
- Maximum working pressure: 150 PSI

WARNING: Not to be used on percussion tools or in areas of high mechanical abuse



| Model No. | Port Size NPT | Price/Each |
|-----------|---------------|------------|
| THZ360 | 1/4 | 42.70 |



AIR MANIFOLDS

Eliminates the need to connect and disconnect each time the tool is changed.

AIR MANIFOLD (3-IN-1)

- Supplies 3 air tools from a single inlet
- Each manifold accepts 3 outlet hoses or couplers
- Compact design
- Economical
- Lightweight aluminum construction



| Model No. | Mfg. No. | Inlet | Outlet | Price/Each |
|-----------|----------|-------------|-------------|------------|
| TZ246 | 62.800C | 1/4 (F) NPT | 1/4 (F) NPT | 14.30 |
| TZ247 | 62.805C | 3/8 (F) NPT | 1/4 (F) NPT | 14.50 |

TOPRING

AIR MANIFOLD (2-IN-1)

- Supplies 2 air tools from a single inlet
- Each manifold accepts 2 outlet hoses or couplers
- Compact design
- Economical
- Brass, nickel plated construction



| Model No. | Mfg. No. | Inlet | Outlet | Price/Each |
|-----------|----------|-------------|-------------|------------|
| TZ248 | 62.850C | 1/4 (F) NPT | 1/4 (F) NPT | 8.99 |
| TZ249 | 62.860C | 1/4 (M) NPT | 1/4 (F) NPT | 9.14 |

MAXPRO AIR TOOL SWIVEL CONNECTORS

- Universal connector that connects portable air tools to an air line
- Improve tool maneuverability, minimize operator fatigue and extends hose life
- Swivel 360° at two pivot points, allowing the air hose to drop directly to the floor



TLZ018



TLZ017

TOPRING

| Model No. | Mfg. No. | Thread NPT | Description | Price/Each |
|-----------|----------|------------|------------------------|------------|
| TLZ016 | 62.712C | 1/4 | Flow regulator only | 22.50 |
| TLZ017 | 62.714C | 1/4 | Universal coupler only | 30.20 |
| TLZ018 | 62.705C | 1/4 | Swivel only | 17.70 |

PNEUMATIC LOCKOUTS

- Prevents fitting from being connected to a pressurized air source
- Stainless steel construction
- Fits virtually all pneumatic fittings in manufacturing facilities

Model No. TLZ098
Mfg. No. S3900
Price/Each \$29.60

Master Lock



IN-LINE FILTERS

Compressed air contains impurities which in time will cause improper operation of equipment and in some cases, equipment failure. The in-line filters eliminate the impurities.

- Portable
- Lightweight
- In-line installation
- Large element to remove foreign particles from contaminated air supplies

Applications

- Air tools
- Air valves and cylinders
- Precision regulators
- Air controls

TOPRING

STANDARD DUTY CONSTRUCTION

- Clear reservoir shows accumulated water taken out of air line
- Button relief valve for draining tapped liquid from reservoir
- Filter can be removed and cleaned



TZ233



HIGH PERFORMANCE CONSTRUCTION

- Anodized aluminum zinc plated steel
- 40 micron porous bronze element



TA845



| Model No. | Mfg. No. | Inlet (F) NPT | Outlet (M) NPT | Price /Each |
|-------------------------|----------|---------------|----------------|-------------|
| STANDARD DUTY | | | | |
| TZ233 | 62.106C | 1/4 | 1/4 | 21.90 |
| HIGH PERFORMANCE | | | | |
| TA845 | 62.120C | 1/4 | 1/4 | 16.10 |

DISPOSABLE IN-LINE DESICCANT FILTERS/DRYERS

Removes all traces of water, oil and dirt by using a porous bronze element for the dirt, an oil removing media for oil vapour and a special filter for removing residual desiccant dust.

Four stage filtration:

- 1st stage: removes dirt
- 2nd stage: removes oil vapours
- 3rd stage: removes water vapours
- 4th stage: removes residual desiccant dust

Features:

- Disposable filter/dryer compact, lightweight
- Can be installed in either direction right at the point of use
- See-through housing shows colour change when dryer needs replacement
- Material highly resistant to chemicals

Specifications

- Compact size: 3 3/4" x 1 11/16"
- Maximum Flow Capacity: 15 SCFM
- Maximum Pressure: 150 PSI
- Maximum Temperature: 130°F

Model No. TA851
Mfg. No. 62.150C
Price/Each \$23.20



TOPRING



IN-LINE LUBRICATORS

SAVES MONEY - INCREASES EFFICIENCY

In-line lubricators save money by reducing down time on air operated equipment. They also avoid the cost of wall mounted lubricating systems. They increase efficiency by preventing sticking of the working mechanism, power loss caused by inadequate lubrication and by keeping the internal mechanism properly oiled.

- Directly attached to the air tool
- Slotted adjustment screw for oil adjustment
- Pressure range: Up to 300 PSI
- Automatic lubrication of air upon passage of rated air flow
- Operates in any position
- Will not leak lubricant into air line upon pressure drop or when disconnected from air line

Applications

- Ideal for air tools
- Especially recommended for staplers and nailers

Construction

- Hard anodized aluminum, steel and nylon

STANDARD DUTY

Pneumatic tools and appliances cannot maintain their full efficiency if the mechanism is impaired by corrosion, condensation or lack of lubrication.

- Automatically lubricates a tool by feeding a measured amount of oil mist each time the tool is cycled
- Max. working pressure: 120 PSI



TZ234

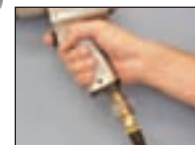

| Model No. | Mfg. No. | Port Size (M) & (F) NPT | Price/Each |
|-----------|----------|-------------------------|------------|
| TZ234 | 62.108C | 1/4 | 18.30 |

HIGH PERFORMANCE

Keeps air-operated hand tools working better, longer.

| Model No. | Mfg. No. | Port Size (M) & (F) NPT | Flow Rate SCFM | Oil Cap. C.C.'s | Price /Each |
|-----------|----------|-------------------------|----------------|-----------------|-------------|
| TA839 | 62.110C | 1/4 | 15 | 5 | 77.70 |
| TA840 | 62.112C | 1/4 | 20 | 9 | 90.10 |
| TA842 | 62.117 | 3/8 | 30 | 22 | 97.10 |
| TA843 | 62.118 | 1/2 | 65 | 22 | 94.40 |



TA839



TOPRING

COMPRESSOR ACCESSORIES

AIR REQUIREMENT ESTIMATING GUIDE

The size of pipes and hoses also contributes to pressure loss in a system. Almost without exception, the single largest pressure loss in a system serving portable tools, is found in two areas - uses of hoses that are either too small or too long, the correct size of hose plays a critical role in avoiding pressure drop. Use of smaller than recommended hose size will result in serious reduction of tool performance. It is recommended to use the shortest hose possible and to make sure it is the correct size for the application. With most air tools the proper air hose size is at least one size larger than that of the air inlet pipe thread.



THZ679



THZ672



THZ674



THZ675

| Description | Continuous Air Consumption at 90 PSI |
|-------------------------|--------------------------------------|
| 22-18 Gauge Staplers | 0.1 SCFM |
| 18 Gauge Brad Nail Guns | 0.1 SCFM |
| Finishing Nail Gun | 0.2 SCFM |
| Coil Roofing Nail Gun | 0.2 SCFM |
| Framing Nail Gun | 0.4 SCFM |
| Caulking Gun | 0.1 SCFM* |
| Grease Gun | 0.8 SCFM |
| Riveter | 1.1 SCFM |
| Engine Cleaner | 6.1 SCFM |
| Conventional Spray Gun | 7.0 SCFM** |
| HVLP Spray Gun | 9.5 SCFM** |
| Screwdriver | 9.6 SCFM |

| Description | Continuous Air Consumption at 90 PSI |
|--------------------------|--------------------------------------|
| Straight Line Sander | 9.6 SCFM |
| 1/4" Mini Ratchet | 12.5 SCFM |
| 1/4" Impact Driver | 14.0 SCFM |
| Mini Die Grinder | 16.5 SCFM |
| Random Orbital Sander | 16.6 SCFM |
| 3/8" Angle Drill | 17.3 SCFM |
| Pull Type Air Nibbler | 17.3 SCFM |
| 4" Angle Disc Grinder | 18.4 SCFM |
| Mini Belt Sander (10 mm) | 18.9 SCFM |
| 3/8" Ratchet | 19.2 SCFM |
| D.A. Sander | 19.2 SCFM |
| Jitterbug Sander | 19.2 SCFM |

| Description | Continuous Air Consumption at 90 PSI |
|-----------------------|--------------------------------------|
| Pistol Grip Shears | 19.2 SCFM |
| Chisel/Hammer | 21.9 SCFM |
| High Speed Sander | 22.7 SCFM |
| 3/8" Reversible Drill | 23.8 SCFM |
| Abrasion Cut Off Tool | 25.4 SCFM |
| Full Size Die Grinder | 25.4 SCFM |
| 1/2" Reversible Drill | 26.4 SCFM |
| 1/2" Impact Wrench | 28.6 SCFM |
| 7" Angle Sander | 29.6 SCFM |
| 7" Vertical Polisher | 31.0 SCFM |
| 3/4" Impact Wrench | 34.7 SCFM |
| 1" Impact Wrench | 87.5 SCFM |

*at 20 PSI **at 40 PSI

PRESSURE CONVERSION

| From | To | mm Hg. | in. Hg. | ft. H ₂ O | atm | PSI | kgf/cm ² | lb/in ² kPa |
|--------------------------|----|----------|---------|----------------------|--------|---------|---------------------|------------------------|
| mm Hg | | 1.0000 | 0.0394 | 0.0446 | 0.0013 | 0.0193 | 0.0013 | 0.133 |
| in. Hg. | | 25.4000 | 1.0000 | 1.134 | 0.3342 | 0.4912 | 0.0345 | 3.386 |
| atm (Bar) | | 760.0000 | 29.9200 | 33.9000 | 1.0000 | 14.7000 | 1.0330 | 101.300 |
| lb/in ² (PSI) | | 51.7100 | 2.0360 | 2.3070 | 0.0680 | 1.0000 | 0.0704 | 6.895 |
| kg/cm ² | | 735.6000 | 28.9600 | 32.840 | 0.9678 | 14.2200 | 1.0000 | 98.050 |
| kPa | | 7.5000 | 0.2953 | 0.3349 | 0.0098 | 0.1450 | 0.0102 | 1.000 |

FLOW RATE CONVERSION

| From | To | litre/sec | litre/min | gallon/min. | ft ³ /sec | ft ³ /min (SCFM) |
|-------------------|----|-----------|-----------|-------------|----------------------|-----------------------------|
| Litre/sec | | 1.0000 | 60.0000 | 15.852 | 0.0357 | 2.1192 |
| Litre/min | | 0.0167 | 1.0000 | 0.2642 | 0.00059 | 0.0357 |
| Gallon/min | | 0.063 | 3.7850 | 1.0000 | 0.00222 | 0.1337 |
| Cu.ft./sec | | 28.3170 | 1699.0200 | 448.8 | 1.0000 | 60.0000 |
| Cu.ft./min (SCFM) | | 0.4719 | 28.3170 | 7.480 | 0.0166 | 1.0000 |

AIR PREPARATION

The lay-out of air-supply piping, the selection of adequate hose sizes and appropriate fittings and couplers and the preparation of air before it enters a tool are very important.

Why efficient treatment of compressed air at the work station is vital?

The harmful agents in a compressed air system are:

LIQUIDS & CONDENSATES:

- Cause line corrosion
- Cause reduced performance of tools and cylinders
- Cause lubricants to wash away

COMPRESSOR OIL:

- Forms corrosive acids from lubricant aerosols
- Forms sticky emulsions, reducing tools' speed and performance
- Forms clogging residues

SOLID CONTAMINANTS:

- Cause premature wear and damage to controls, tools and cylinders
- Cause seizing and scoring of cylinders and air powered motors

Proper air preparation will result in improved performance and increased tool life.

**SEE PAGES 1204-1232
FOR AIR TOOLS**

FILTERING, REGULATING & LUBRICATING AT THE WORK STATION

Compressed-air treatment program units and modular components are indispensable to insure maximum efficiency of controls, pneumatic tools, air cylinders and other pneumatic equipment.

THEY ALLOW:

- To prolong pneumatic equipment life as well as of air cylinders
- Proper filtering and lubricating of air prolong their life and top performance by a ratio of 1 to 20
- Increase tools and equipment performance up to standard of efficiency, by preventing damages due to overheat and seizure
- They insure a dependable source of smooth vibrationless power to operate tools at an efficient and steady speed
- To reduce downtime, therefore improve the overall performance and efficiency of any compressed air system, tools, air cylinders or other pneumatic equipment

Proper usage of compressed air calls for:

FILTERS/MICRO COALESCING:

- To remove moisture and particles

REGULATORS:

- To control pressure for the particular use

GAUGES:

- To show pressure

LUBRICATORS:

- To protect power tools by injecting a metered quantity of lubricant

Components may be purchased separately or in pre-assembled combinations

SUGGESTIONS FOR INSTALLING FRL & DRAINS

The filter, regulator, and lubricator should be installed in the order shown in the illustration. Individual take-off lines to the FRL unit and air tool(s) should be from the top of the compressed air line.

To trap and expel water, sludge, and other contaminants which may collect on the bottom of the air line, a mechanical drain should be used. Mechanical drains should be installed at low points in the piping system and at the far end of the distribution system.

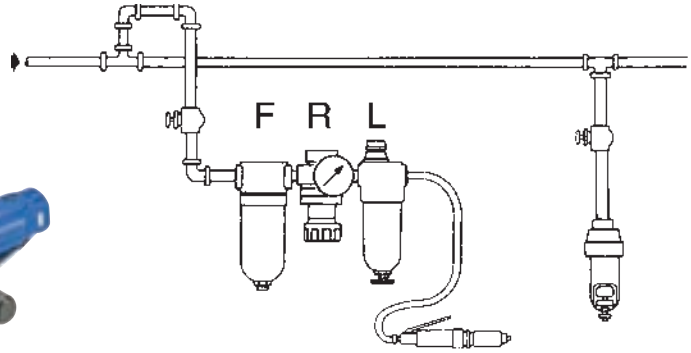

APPROXIMATE AIR CONSUMPTION FOR SELECTED AIR TOOLS

| | | | | | |
|-------|--------|--|-------|--------|---|
| 4-7 | C.F.M. | Wire and terminal wrapping tools | 21-23 | C.F.M. | Medium screwdrivers (to 23 ft./lbs.) |
| 8-13 | C.F.M. | Small air drills (1/4" cap.) | 22-34 | C.F.M. | Large impact tools (3/4" sq. drive) |
| 8-13 | C.F.M. | Small nut runners and impact wrenches (1/4" sq. drive) | 23-25 | C.F.M. | Foundry casting cleaners |
| 8-13 | C.F.M. | Small air screwdrivers to 1" dia. screws (16 ft./lbs.) | 25-27 | C.F.M. | Standard back fill tampers |
| 8-13 | C.F.M. | Small orbital sanders (automotive type) | 24-30 | C.F.M. | Small (2" wheel) air grinders (horizontal) |
| 9-14 | C.F.M. | Medium impact tools (3/8" sq. drive) | 27-32 | C.F.M. | Foundry casting chippers |
| 10-13 | C.F.M. | Small air die grinders (high speed) | 34-60 | C.F.M. | Large impact tools (1" sq. drive) |
| 13-15 | C.F.M. | Foundry casting scalars | 36-39 | C.F.M. | Medium cup wheel grinders (7" wheel), 1 HP (vertical) |
| 14-17 | C.F.M. | Large impact wrenches (1/2" sq. drive) | 35-40 | C.F.M. | Disc sanders (7" size), 1 HP |
| 14-29 | C.F.M. | Foundry sandtampers | 39-42 | C.F.M. | Medium duty (4: wheel) horizontal grinders |
| 15-20 | C.F.M. | Reciprocating saws - files | 48-65 | C.F.M. | Heavy duty (6" wheel) horizontal grinders |
| 19-20 | C.F.M. | Large impact tools (5/8" sq. drive) | 60-65 | C.F.M. | Large cup wheel vertical grinder (7" wheel), 2 HP |

TYPICAL COMPRESSED AIR NETWORK

1. Compressor and tank
2. Electronic automatic drain
3. Flexible vibration absorbing hose
4. Pre-filter
5. Refrigerated air dryer
6. Bypass circuit with isolation ball valve
7. After filter
8. Air line pipe
9. Y strainer to capture large contaminants
10. Mechanical automatic drain
11. Pre-formed drop pipe
12. Filter/regulator + lubricator air treatment unit
13. Water trap T drop fitting
14. Filter/regulator air treatment unit
15. Isolation ball valve

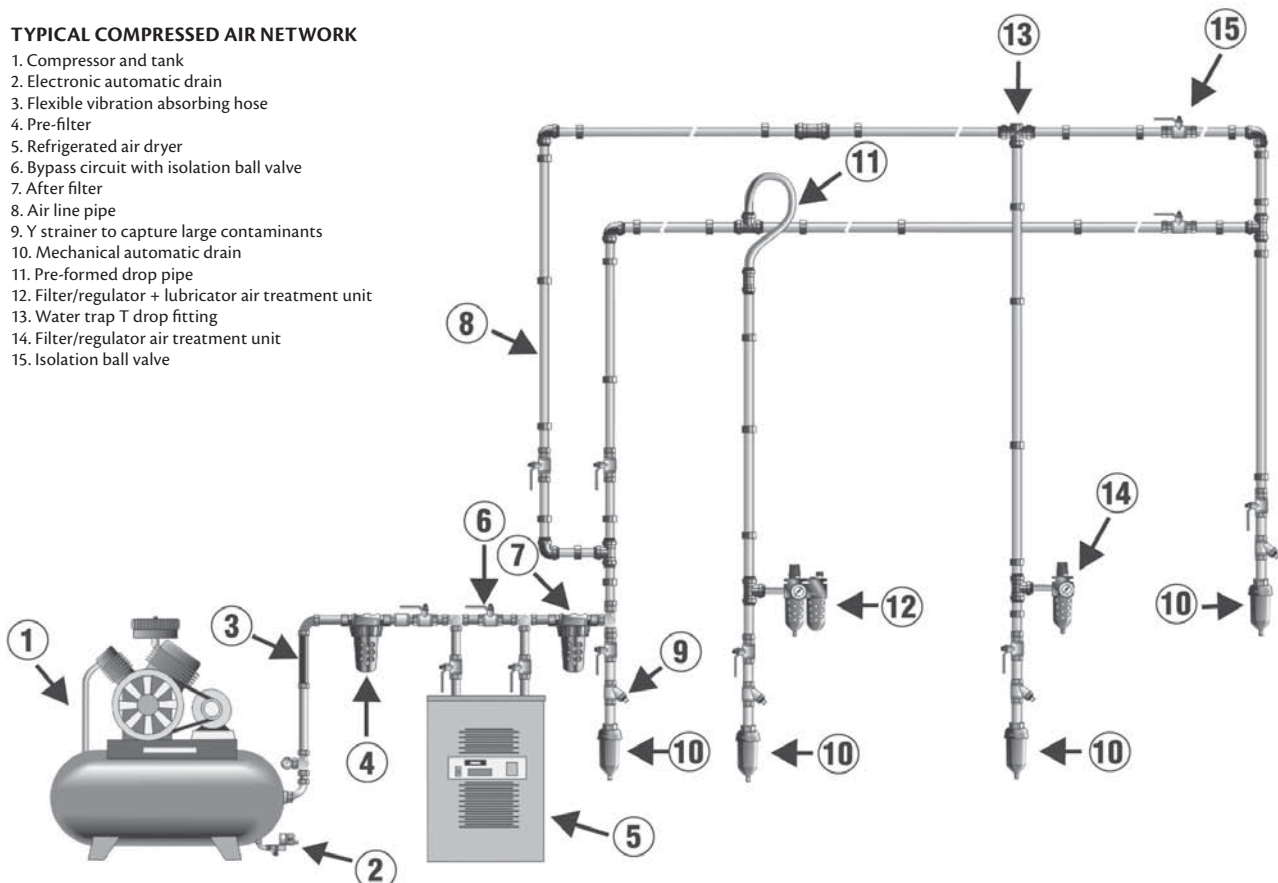



AIR LINE FILTERS

A filter is a necessity in every compressed air system. Filters remove the danger of corrosive damage to air tools and equipment by removing condensed moisture, pipe scale, dirt and rust from the air stream.



Micro Coalescing Filter



Pressure Regulator



Air Line Lubricator



Filter/Regulator



Filter/Regulator/Lubricator



Filter/Regulator and Lubricator



Filter/Regulator and Micro Coalescing Filter

AIR LINE FILTERS

Selection:

- Filter element rating is the prime selection criteria
- For most industrial applications, filter elements rated at 40 micrometres are adequate
- When necessary, filtration down to 20 or 5 micrometres or finer can be provided
- However, finer filtration increases pressure drop through the element
- Next, the flow capacity and pressure rating of the filter should be considered
- Finally, port size should match piping to avoid unnecessary pressure drops through restricting adapters
- Filter should be located as far from the compressor as possible to trap as much condensation as possible

MICRO COALESCING FILTERS

- Used in compressed air systems that require compressed air virtually free of oil vapours
- Remove liquid aerosols and very small particles
- The efficiency of removing such liquid aerosols is as high as 99.9%
- A pre-filter should always be used to increase life and efficiency of micro mist filters
- Typical application: Paint spraying

PRESSURE REGULATORS

Operation:

- Pressure regulators are used in compressed-air systems to reduce system pressure to a level suitable to operate air tools and equipment
- Regulators maintain the reduced pressure despite changes in the inlet pressure and changes in downstream flow requirements
- Pressure regulators reduce line pressure to a usable range, at a lower pressure than the compressor is set to deliver
- Regulators maintain a steady flow of air regardless of the fluctuations that may take place in line pressure
- Pneumatic equipment or tools operating at higher than recommended pressure, waste the energy to generate that pressure
- It creates a potential safety hazard and the tool will wear out prematurely. Operating below specified pressure can cause the tool to fail to meet performance specifications, therefore, precise air pressure control is essential for efficient operation of compressed air equipment

Selection:

- Inlet pressure rating and downstream controlled range, as well as flow capacity must be determined before selecting a regulator
- Port size should match piping size
- Required response time relieving capability and type of adjustment are other considerations

AIR LINE LUBRICATORS

Operation:

- Most pneumatic tools require oil lubrication for proper operation and long service life
- Too little oil can cause excessive wear and premature failure
- Too much oil is wasteful and can become a contaminant
- Intermittent lubrication may be the worst situation because the oil film can dry out to form sludges and varnishes on internal surfaces
- Lubricators protect expensive power tools
- Lubricators are ideal for lubrication of air tools or equipment, they inject a finely divided "fog" of oil into the air stream
- External adjustment and visible sight dome make precise adjustment easy
- This unit should be located as close as possible to the tool or the point where lubrication is required, a lubricator should never be located between compressor and filter or regulator, or on an air line supply to a paint gun
- Whenever possible, lubricators should be located at an elevation higher than the tools being lubricated

COMBINATION FILTER/REGULATORS

Operation:

- Filter/regulators are used in compressed air systems to filter air and to regulate pressure
- Filter/regulators combine the functions in one compact, space saving unit

COMBINATION FILTER/REGULATOR/LUBRICATOR

Selection:

- When selecting the individual filter/regulator/lubricator unit, the air consumption of the tool(s) to be serviced should be appropriate with the flow capacity of the unit
- Filter/regulator/lubricator should be as close as practical to the tool or work station
- Filter/regulator/lubricator should be in an area of easy accessibility because these units require regular maintenance
- A shut-off valve (ball valve) should be installed ahead of the unit to facilitate maintenance
- An air line may be equipped with the best filters and lubricators available, but if they are not positioned in the system where they do the most good, or if filters are not drained, or if lubricator reservoirs are not re-filled, the money spent for their use may have been wasted

POPULAR COMBINATIONS

FILTER/REGULATOR + LUBRICATOR OR FILTER + REGULATOR + LUBRICATOR

Typical application: Air tools

- These units are ready for immediate installation into the air line

FILTER/REGULATOR + MICRO COALESCING FILTER

Typical application: Paint spraying

- This unit is ideal for body shop operations where filtered, dried and regulated air supply is necessary for painting
- This unit provides the painter with a clean, moisture free air supply and saves money

MODULAR FRL SYSTEMS

TOPRING

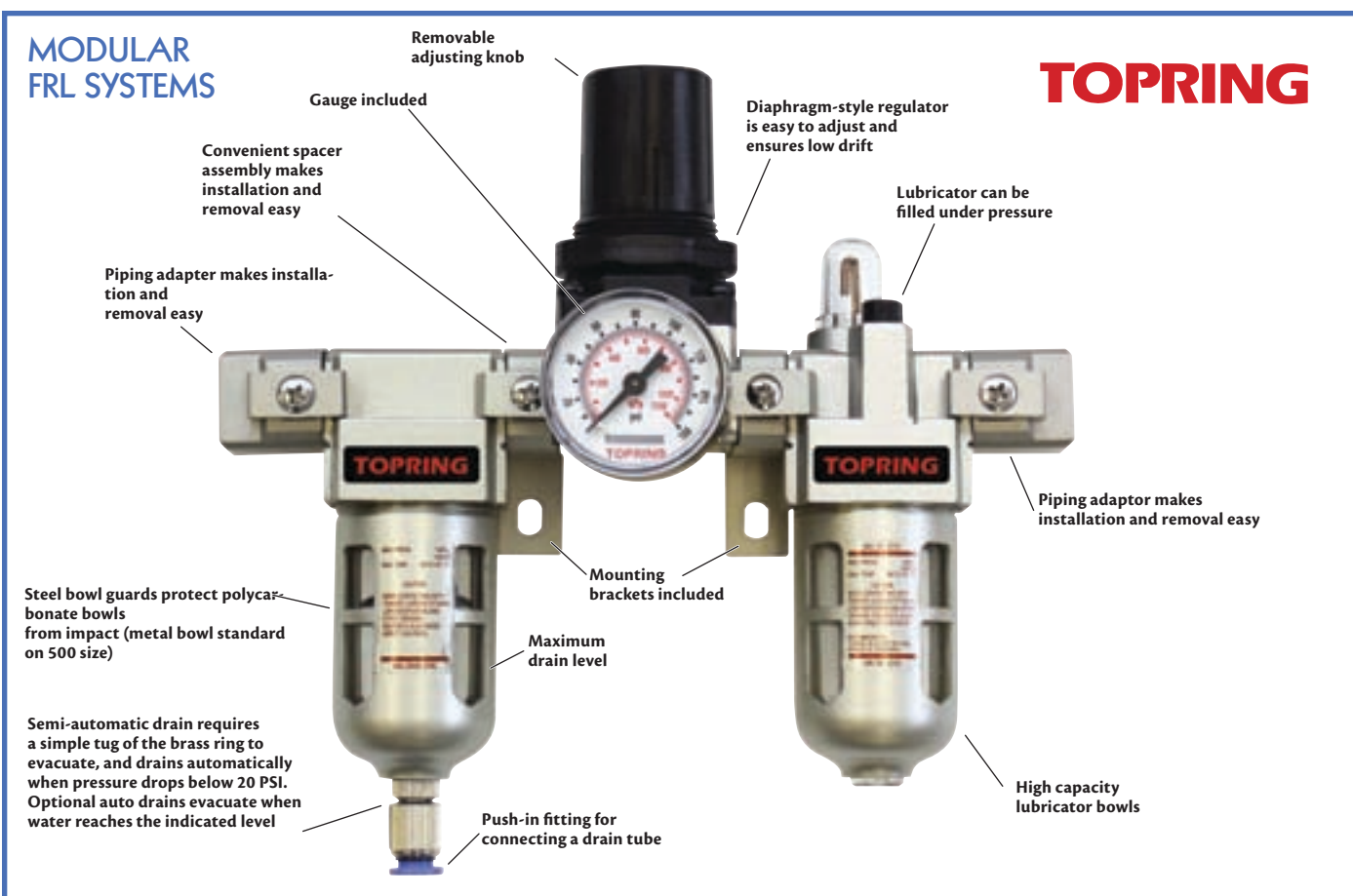

AIRFLO MODULAR COMBINATION UNITS FILTER + REGULATOR + LUBRICATOR + GAUGE

- Accurate pressure control
- Lubrication automatically proportioned to air flow
- Pressure gauge, piping adaptors and mounting bracket included
- With the piping adapter, it is easy to remove unit for maintenance



TOPRING

| Model No. | Mfg. No. | Port Size" | Max Air Flow @ 100 PSI | Max PSI | Reduced Pressure Range | Bowl Type | Bowl Capacity | Drain | Gauge Port Size" | Series | Price /Each |
|-----------|----------|-------------|------------------------|---------|------------------------|-----------------------------|---------------|-----------|------------------|--------|-------------|
| TLZ602 | 51.210 | 1/4 (F) NPT | 18 SCFM | 150 | 5-125 | Polycarbonate w/steel guard | 0.5 fl.oz. | Semi-auto | 1/8 (F) NPT | 200 | 154.00 |
| TLZ611 | 51.310 | 1/4 (F) NPT | 70 SCFM | 150 | 5-125 | Polycarbonate w/steel guard | 0.7 fl.oz. | Semi-auto | 1/8 (F) NPT | 300 | 193.00 |
| TLZ613 | 51.315 | 3/8 (F) NPT | 70 SCFM | 150 | 5-125 | Polycarbonate w/steel guard | 0.7 fl.oz. | Semi-auto | 1/8 (F) NPT | 300 | 198.00 |
| TLZ637 | 51.410 | 3/8 (F) NPT | 141 SCFM | 150 | 5-125 | Polycarbonate w/steel guard | 1.6 fl.oz. | Semi-auto | 1/4 (F) NPT | 400 | 254.00 |
| TLZ639 | 51.415 | 1/2 (F) NPT | 141 SCFM | 150 | 5-125 | Polycarbonate w/steel guard | 1.6 fl.oz. | Semi-auto | 1/4 (F) NPT | 400 | 251.00 |
| TLZ663 | 51.510 | 3/4 (F) NPT | 175 SCFM | 150 | 5-125 | Die cast alum w/sight glass | 4.4 fl.oz. | Semi-auto | 1/4 (F) NPT | 500 | 365.00 |
| TLZ665 | 51.515 | 1 (F) NPT | 175 SCFM | 150 | 5-125 | Die cast alum w/sight glass | 4.4 fl.oz. | Semi-auto | 1/4 (F) NPT | 500 | 376.00 |

AIRFLO COMPACT MODULAR COMBINATION UNITS FILTER/REGULATOR + LUBRICATOR + GAUGE

- Accurate pressure control
- Lubrication automatically proportioned to air flow
- Pressure gauge, piping adaptors and mounting bracket included

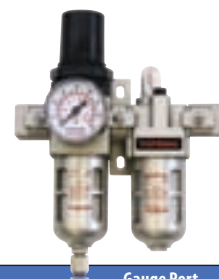

TOPRING

| Model No. | Mfg. No. | Port Size" | Max Air Flow @ 100 PSI | Max PSI | Reduced Pressure Range | Bowl Type | Bowl Capacity | Drain | Gauge Port Size" | Series | Price /Each |
|-----------|----------|-------------|------------------------|---------|------------------------|-----------------------------|---------------|-----------|------------------|--------|-------------|
| TLZ603 | 51.220 | 1/4 (F) NPT | 18 SCFM | 150 | 5-125 | Polycarbonate w/steel guard | 0.5 fl.oz. | Semi-auto | 1/8 (F) NPT | 200 | 142.00 |
| TLZ615 | 51.320 | 1/4 (F) NPT | 70 SCFM | 150 | 5-125 | Polycarbonate w/steel guard | 0.7 fl.oz. | Semi-auto | 1/8 (F) NPT | 300 | 170.00 |
| TLZ617 | 51.325 | 3/8 (F) NPT | 70 SCFM | 150 | 5-125 | Polycarbonate w/steel guard | 0.7 fl.oz. | Semi-auto | 1/8 (F) NPT | 300 | 170.00 |
| TLZ641 | 51.420 | 3/8 (F) NPT | 105 SCFM | 150 | 5-125 | Polycarbonate w/steel guard | 1.6 fl.oz. | Semi-auto | 1/4 (F) NPT | 400 | 228.00 |
| TLZ643 | 51.425 | 1/2 (F) NPT | 105 SCFM | 150 | 5-125 | Polycarbonate w/steel guard | 1.6 fl.oz. | Semi-auto | 1/4 (F) NPT | 400 | 234.00 |

COMPRESSOR ACCESSORIES

AIRFLO MODULAR FILTER/REGULATORS

- Removes water through centrifugal force
- Filters contaminants down to 5 micrometres
- Accurate pressure control
- Pressure gauge and mounting bracket included

TOPRING

| Model No. | Mfg. No. | Port Size" | Max Air Flow @ 100 PSI | Max PSI | Reduced Pressure Range | Bowl Type | Bowl Capacity | Drain | Gauge Port Size" | Series | Price /Each |
|-----------|----------|-------------|------------------------|---------|------------------------|-----------------------------|---------------|-----------|------------------|--------|-------------|
| TLZ608 | 51.250 | 1/4 (F) NPT | 19 SCFM | 150 | 5-125 PSI | Polycarbonate w/steel guard | 0.5 fl.oz. | Semi-auto | 1/8 (F) NPT | 200 | 79.10 |
| TLZ627 | 51.350 | 1/4 (F) NPT | 70 SCFM | 150 | 5-125 PSI | Polycarbonate w/steel guard | 0.7 fl.oz. | Semi-auto | 1/8 (F) NPT | 300 | 89.70 |
| TLZ629 | 51.355 | 3/8 (F) NPT | 70 SCFM | 150 | 5-125 PSI | Polycarbonate w/steel guard | 0.7 fl.oz. | Semi-auto | 1/8 (F) NPT | 300 | 104.00 |
| TLZ653 | 51.450 | 3/8 (F) NPT | 141 SCFM | 150 | 5-125 PSI | Polycarbonate w/steel guard | 1.6 fl.oz. | Semi-auto | 1/4 (F) NPT | 400 | 150.00 |
| TLZ655 | 51.455 | 1/2 (F) NPT | 141 SCFM | 150 | 5-125 PSI | Polycarbonate w/steel guard | 1.6 fl.oz. | Semi-auto | 1/4 (F) NPT | 400 | 150.00 |



AIRFLO MODULAR FILTERS

- Removes water through centrifugal force
- Filters contaminants down to 5 micrometres
- Mounting bracket included

TOPRING

| Model No. | Mfg. No. | Port Size" | Max Air Flow @ 100 PSI | Max PSI | Bowl Type | Bowl Capacity | Drain | Series | Price /Each |
|-----------|----------|-------------|------------------------|---------|-----------------------------|---------------|-----------|--------|-------------|
| TLZ609 | 51.260 | 1/4 (F) NPT | 27 SCFM | 150 | Polycarbonate w/steel guard | 0.5 fl.oz. | Semi-auto | 200 | 31.10 |
| TLZ631 | 51.360 | 1/4 (F) NPT | 70 SCFM | 150 | Polycarbonate w/steel guard | 0.7 fl.oz. | Semi-auto | 300 | 52.40 |
| TLZ633 | 51.365 | 3/8 (F) NPT | 70 SCFM | 150 | Polycarbonate w/steel guard | 0.7 fl.oz. | Semi-auto | 300 | 52.40 |
| TLZ657 | 51.460 | 3/8 (F) NPT | 141 SCFM | 150 | Polycarbonate w/steel guard | 1.6 fl.oz. | Semi-auto | 400 | 70.90 |
| TLZ659 | 51.465 | 1/2 (F) NPT | 141 SCFM | 150 | Polycarbonate w/steel guard | 1.6 fl.oz. | Semi-auto | 400 | 76.20 |
| TLZ675 | 51.560 | 3/4 (F) NPT | 247 SCFM | 150 | Die cast alum w/sight glass | 4.4 fl.oz. | Semi-auto | 500 | 128.00 |
| TLZ677 | 51.565 | 1 (F) NPT | 247 SCFM | 150 | Die cast alum w/sight glass | 4.4 fl.oz. | Semi-auto | 500 | 128.00 |



AIRFLO MODULAR REGULATORS

- Removable locking Push/Pull adjusting knob
- Accurate pressure control
- Pressure gauge and mounting bracket included

TOPRING

| Model No. | Mfg. No. | Port Size" | Reduced Pressure Range | Max Air Flow @ 100 PSI | Max PSI | Gauge Port Size" | Series | Price /Each |
|-----------|----------|-------------|------------------------|------------------------|---------|------------------|--------|-------------|
| TLZ605 | 51.240 | 1/4 (F) NPT | 5-125 PSI | 19 SCFM | 150 | 1/8 (F) NPT | 200 | 39.70 |
| TLZ621 | 51.340 | 1/4 (F) NPT | 5-125 PSI | 70 SCFM | 150 | 1/8 (F) NPT | 300 | 56.30 |
| TLZ624 | 51.345 | 3/8 (F) NPT | 5-125 PSI | 70 SCFM | 150 | 1/8 (F) NPT | 300 | 56.90 |
| TLZ647 | 51.440 | 3/8 (F) NPT | 5-125 PSI | 212 SCFM | 150 | 1/4 (F) NPT | 400 | 73.90 |
| TLZ650 | 51.445 | 1/2 (F) NPT | 5-125 PSI | 212 SCFM | 150 | 1/4 (F) NPT | 400 | 73.10 |
| TLZ669 | 51.540 | 3/4 (F) NPT | 5-125 PSI | 282 SCFM | 150 | 1/4 (F) NPT | 500 | 125.00 |
| TLZ672 | 51.545 | 1 (F) NPT | 5-125 PSI | 282 SCFM | 150 | 1/4 (F) NPT | 500 | 125.00 |



AIRFLO MODULAR LUBRICATORS

- Lubrication automatically proportioned to air flow
- Mounting bracket included

TOPRING

| Model No. | Mfg. No. | Port Size" | Max Air Flow @ 100 PSI | Max PSI | Bowl Type | Bowl Capacity | Series | Price /Each |
|-----------|----------|-------------|------------------------|---------|------------------------------|---------------|--------|-------------|
| TLZ604 | 51.230 | 1/4 (F) NPT | 28 SCFM | 150 | Polycarbonate w/steel guard | 0.85 fl.oz. | 200 | 42.70 |
| TLZ619 | 51.330 | 1/4 (F) NPT | 70 SCFM | 150 | Polycarbonate w/steel guard | 1.7 fl.oz. | 300 | 64.20 |
| TLZ620 | 51.335 | 3/8 (F) NPT | 70 SCFM | 150 | Polycarbonate w/steel guard | 1.7 fl.oz. | 300 | 64.20 |
| TLZ645 | 51.430 | 3/8 (F) NPT | 176 SCFM | 150 | Polycarbonate w/steel guard | 1.6 fl.oz. | 400 | 73.40 |
| TLZ646 | 51.435 | 1/2 (F) NPT | 176 SCFM | 150 | Polycarbonate w/steel guard | 1.6 fl.oz. | 400 | 70.80 |
| TLZ667 | 51.530 | 3/4 (F) NPT | 247 SCFM | 150 | Die cast alum. w/sight glass | 4.4 fl.oz. | 500 | 124.00 |
| TLZ668 | 51.535 | 1 (F) NPT | 247 SCFM | 150 | Die cast alum. w/sight glass | 4.4 fl.oz. | 500 | 124.00 |



AIRFLO MODULAR PIPING ADAPTORS

- Each item listed below includes two adaptors

TOPRING

| Model No. | Mfg. No. | Port Size" | Series | Price /Each |
|-----------|----------|-------------|--------|-------------|
| TLZ690 | 51.950 | 1/4 (F) NPT | 200 | 33.90 |
| TLZ691 | 51.951 | 1/4 (F) NPT | 300 | 49.90 |
| TLZ692 | 51.952 | 3/8 (F) NPT | 300 | 49.90 |
| TLZ693 | 51.953 | 3/8 (F) NPT | 400 | 84.40 |
| TLZ694 | 51.954 | 1/2 (F) NPT | 400 | 68.00 |
| TLZ695 | 51.955 | 3/4 (F) NPT | 500 | 84.90 |
| TLZ696 | 51.956 | 1 (F) NPT | 500 | 84.90 |



COMPRESSOR ACCESSORIES

MAXDRAIN ELECTRONIC AUTOMATIC DRAINS

- Cost effective solution for regular, reliable condensation removal
- Fully automatic
- No maintenance
- Adjustable interval and discharge time
- Valve opens 0.5 to 10 seconds in 0.5 to 45 minute cycle times
- Test switch - for routine inspection and depressurization
- Solid-state timer for long life and reliability
- Rugged fire-resistant ABS housing

| Model No. | Mfg. No. | Inlet | Price/Each |
|--------------------------------|----------|-------------------------------|---------------|
| WITH STRAINER AND VALVE | | | |
| TGA424 | 59.345 | 1/2 (M) NPT" and 1/4 (F) NPT" | 148.00 |



TGA424

ASME AIR SAFETY VALVES

- Designed to protect air compressor tanks and other unfired pressure vessels by exhausting when the maximum pressure is reached
- High quality, corrosion-resistant
- In accordance to ASME code and OSHA approved



TOPRING



| Model No. | Pressure ±3% PSI | Flow Cap. SCFM | Price /Each |
|--------------|------------------|----------------|--------------|
| TA803 | 50 | 47 | 20.30 |
| TA804 | 75 | 66 | 20.30 |
| TA805 | 115 | 96 | 20.30 |
| TA806 | 125 | 103 | 20.30 |
| TA807 | 140 | 115 | 20.30 |

| Model No. | Pressure ±3% PSI | Flow Cap. SCFM | Price /Each |
|--------------|------------------|----------------|--------------|
| TA808 | 155 | 126 | 20.30 |
| TA809 | 163 | 132 | 20.30 |
| TA810 | 190 | 152 | 20.30 |
| TA811 | 200 | 160 | 20.30 |

DESICCANT AIR DRYER SYSTEMS

TOPRING

Nevada 3 stage desiccant system is engineered to provide high-quality air. Effective for removing liquid condensate (dirt, oil, water) but ideal for removing residual water vapour and aerosols. Delivers extremely dry compressed air without the use of electricity or refrigerants. Silica gel provides maximum moisture absorption. System consists of the following: filter (5 micrometres) with auto drain, coalescing filter (0.7 micrometre) with auto drain, desiccant dryer (30 CFM capacity) with sight glass indicating need for service, pressure regulator with gauge and mounting bracket.

SPECIFICATIONS:

Max. Working Pressure: 250 PSI
 Port Size: 1/2" NPT
 Air Flow Capacity: 30 SCFM

| Model No. | Description | Price /Each |
|--------------|-------------------------------------|---------------|
| TZ906 | 3-stage heavy-duty desiccant system | P.O.A. |
| TZ907 | Desiccant silica gel (5 lbs.) | 145.00 |

3 STAGE FILTRATION:

1. Centrifugal unit removes water, oil and dirt particles down to 5 micrometres
2. Coalescent filters out oil and water aerosols and smaller dirt down to 0.3 micrometre
3. Desiccant dryer removes all remaining water vapour



STANDARD DUTY DESICCANT SYSTEMS

TOPRING

The standard duty desiccant system offers the same benefits as the heavy-duty system, but is designed for less frequent use. It is also a 3-stage system engineered to provide high quality air. It removes dirt, water, oil, and uncondensed moisture from compressed air lines. Very efficient at protecting expensive and sensitive air tools. Does not require electricity or refrigerants to provide extremely dry compressed air. Silica gel provides maximum absorption, which can be monitored through a small sight glass. When the blue gel turns pink, the gel is then saturated with water and should be replaced with fresh gel to allow the system to remain effective. System consists of a filter (5 micrometres) with auto drain, coalescing filter (0.1 micrometres) with auto drain, desiccant dryer, filter/regulator with gauge, and a safety slide valve.

SPECIFICATIONS

Max. Working Pressure: 175 PSI
 Port Size: 1/2" NPT
 Air Flow Capacity: 20 SCFM

| Model No. | Description | Price /Each |
|--------------|--|---------------|
| TG132 | 3-stage standard duty desiccant system | 603.00 |
| TZ907 | Desiccant silica gel (5 lbs.) | 145.00 |

3 STAGE FILTRATION:

1. Integral filter/regulator removes particulates down to 5 micrometres in size, to protect the regulator, which then reduces the pressure to the desired pressure setting
2. Coalescing filter removes 99.99% of oil aerosols and microscopic particles down to 0.1 micrometres in size
3. Desiccant dryer removes all remaining water vapour and a 40 micrometre filter element removes traces of any desiccant dust before it leaves the system



WATER SEPARATORS

- Cost effective way of ensuring that bulk water is removed from compressed air
- Ideal as a first treatment step between the compressor and receiver tank
- Requires no electricity and almost no maintenance
- Uses centrifugal force to remove up to 99% of bulk water
- Very low maintenance costs
- Simple and easy to install
- Efficient automatic drain
- Robust Aluminum body
- Maximum working pressure 232 PSI

TOPRING



| Model No. | Mfg. No. | Pipe Connection" (F) NPT" | Flow Capacity SCFM | Weight lb. | Dimensions (in) | | Price /Each |
|---------------|----------|---------------------------|--------------------|------------|-----------------|--------|---------------|
| | | | | | Diameter | Height | |
| TLV335 | 56.010 | 1/2 | 88 | 2.4 | 3.42 | 8.23 | 294.00 |
| TLV336 | 56.020 | 3/4 | 144 | 3.1 | 3.42 | 10.98 | 309.00 |
| TLV337 | 56.030 | 1 | 232 | 8.4 | 5.12 | 12.4 | 366.00 |
| TLV338 | 56.040 | 1 1/2 | 373 | 9.3 | 5.12 | 16.34 | 457.00 |
| TLV339 | 56.050 | 1 1/2 | 488 | 10.6 | 5.12 | 20.28 | 512.00 |
| TLV340 | 56.060 | 1 1/2 | 600 | 13.7 | 5.12 | 28.15 | 708.00 |

COMPRESSOR ACCESSORIES

FILTERS/REGULATORS/LUBRICATORS (GAUGE INCLUDED)

- High-flow capacity reduces costly pressure drop
- Compact size allows greater design flexibility
- **Heavy-Duty:** High-capacity performance featuring rugged design for the most demanding applications

TOPRING

| Model No. | NPT Size" | Max SCFM @ 100 PSI | Max PSI | Reduced Pressure Range PSI | Max Temp. °F | Drain Type | Bowl Type | Bowl Cap. oz. | H" | W" | Price /Each |
|---|-----------|--------------------|---------|----------------------------|--------------|------------|----------------------|---------------|----------|---------|-------------|
| COMPACT MODULAR DESIGN, 5-MICROMETRES FILTRATION | | | | | | | | | | | |
| TA689 | 1/4 | 31 | 150 | 0-125 | 125 | Manual | Polyurethane | 1.5 | 7 1/16 | 4 25/32 | 238.00 |
| TA690 | 1/4 | 31 | 150 | 0-125 | 125 | Auto | Polyurethane | 1.5 | 7 1/16 | 4 25/32 | 247.00 |
| TA693 | 1/4 | 23 | 150 | 0-125 | 125 | Manual | Polyurethane | 3.8 | 8 1/16 | 6 35/64 | 307.00 |
| TA694 | 1/4 | 23 | 150 | 0-125 | 125 | Auto | Polyurethane | 3.8 | 8 1/16 | 6 35/64 | 351.00 |
| TA697 | 3/8 | 45 | 150 | 0-125 | 125 | Manual | Polyurethane | 3.8 | 8 1/16 | 6 35/64 | 307.00 |
| TA698 | 3/8 | 45 | 150 | 0-125 | 125 | Auto | Polyurethane | 3.8 | 8 1/16 | 6 35/64 | 351.00 |
| TA701 | 1/2 | 60 | 150 | 0-125 | 125 | Manual | Polyurethane | 3.8 | 8 1/16 | 6 35/64 | 307.00 |
| TA702 | 1/2 | 60 | 150 | 0-125 | 125 | Auto | Polyurethane | 3.8 | 8 1/16 | 6 35/64 | 351.00 |
| TA703 | 1/2 | 60 | 250 | 0-125 | 150 | Manual | Zinc | 3.8 | 8 1/16 | 6 35/64 | 337.00 |
| STANDARD DUTY MODULAR DESIGN, 5-MICROMETRES FILTRATION | | | | | | | | | | | |
| TA705 | 1/2 | 110 | 150 | 0-125* | 125 | Manual | Polyurethane w/guard | 8.5 | 10 21/64 | 8 1/16 | 380.00 |
| TA706 | 1/2 | 110 | 150 | 0-125* | 125 | Auto | Polyurethane w/guard | 8.5 | 10 21/64 | 8 1/16 | 424.00 |
| TA709 | 3/4 | 125 | 150 | 0-125* | 125 | Manual | Polyurethane w/guard | 8.5 | 10 21/64 | 8 1/16 | 389.00 |
| TA710 | 3/4 | 125 | 150 | 0-125* | 125 | Auto | Polyurethane w/guard | 8.5 | 10 21/64 | 8 1/16 | 433.00 |
| HEAVY-DUTY, 5-MICROMETRES FILTRATION | | | | | | | | | | | |
| TA713 | 1 | 240 | 250 | 0-125** | 125 | Manual | Zinc | 16 | 11 | 15 3/4 | 758.00 |
| TA714 | 1 | 240 | 175 | 0-125** | 125 | Auto | Zinc | 16 | 11 | 15 3/4 | 778.00 |
| TA715 | 1 1/4 | 325 | 250 | 0-125** | 125 | Manual | Zinc | 16 | 11 11/32 | 16 1/2 | 921.00 |
| TA716 | 1 1/4 | 325 | 175 | 0-125** | 125 | Auto | Zinc | 16 | 11 11/32 | 16 1/2 | 941.00 |
| TA717 | 1 1/2 | 400 | 250 | 0-125** | 125 | Manual | Zinc | 16 | 11 11/32 | 16 1/2 | 894.00 |
| TA718 | 1 1/2 | 400 | 175 | 0-125** | 125 | Auto | Zinc | 16 | 11 11/32 | 16 1/2 | 914.00 |

*Also available 0-25 PSI, 0-60 PSI, 0-250 PSI **Also available 0-250 PSI



Compact Design w/Polyurethane Bowl

TA689

Compact Design w/Zinc Bowl



TA703



Heavy-Duty Design w/Zinc Bowl

TA713

FILTERS/REGULATORS & COALESCING FILTERS (GAUGE INCLUDED)

- High-flow capacity reduces costly pressure drop
- Compact size allows greater design flexibility
- Lightweight construction for ease of installation

TOPRING

| Model No. | NPT Size" | Max SCFM @ 100 PSI | Max PSI | Reduced Pressure Range PSI | Max Temp. °F | Drain Type | Bowl Type | Bowl Cap. oz. | H" | W" | Price /Each |
|---|-----------|--------------------|---------|----------------------------|--------------|------------|----------------------|---------------|----------|---------|-------------|
| COMPACT MODULAR DESIGN, 5-MICROMETRES FILTRATION | | | | | | | | | | | |
| TA743 | 1/4 | 20 | 150 | 0-125 | 125 | Manual | Polyurethane | 1.5 | 7 3/64 | 3 13/64 | 246.00 |
| TZ031 | 1/4 | 20 | 150 | 0-125 | 125 | Auto | Polyurethane | 1.5 | 7 3/64 | 3 13/64 | 264.00 |
| TA745 | 1/4 | 40 | 150 | 0-125 | 125 | Manual | Polyurethane w/Guard | 3.8 | 8 1/16 | 4 23/64 | 340.00 |
| TA746 | 1/4 | 40 | 150 | 0-125 | 125 | Auto | Polyurethane w/Guard | 3.8 | 8 1/16 | 4 23/64 | 428.00 |
| TA747 | 1/4 | 40 | 250 | 0-125 | 150 | Manual | Zinc | 3.8 | 8 1/16 | 4 23/64 | 368.00 |
| TA748 | 1/4 | 40 | 175 | 0-125 | 125 | Auto | Zinc | 3.8 | 8 1/16 | 4 23/64 | 461.00 |
| TA749 | 3/8 | 43 | 150 | 0-125 | 125 | Manual | Polyurethane w/Guard | 3.8 | 8 1/16 | 4 23/64 | 339.00 |
| TA750 | 3/8 | 43 | 150 | 0-125 | 125 | Auto | Polyurethane w/Guard | 3.8 | 8 1/16 | 4 23/64 | 428.00 |
| TA751 | 3/8 | 43 | 250 | 0-125 | 150 | Manual | Zinc | 3.8 | 8 1/16 | 4 23/64 | 368.00 |
| TA752 | 3/8 | 43 | 175 | 0-125 | 125 | Auto | Zinc | 3.8 | 8 1/16 | 4 23/64 | 462.00 |
| TA761 | 1/2 | 43 | 150 | 0-125 | 125 | Manual | Polyurethane w/Guard | 3.8 | 8 1/16 | 4 23/64 | 340.00 |
| TA762 | 1/2 | 43 | 150 | 0-125 | 125 | Auto | Polyurethane w/Guard | 3.8 | 8 1/16 | 4 23/64 | 428.00 |
| TA763 | 1/2 | 43 | 250 | 0-125 | 150 | Manual | Zinc | 3.8 | 8 1/16 | 4 23/64 | 368.00 |
| TA764 | 1/2 | 43 | 175 | 0-125 | 125 | Auto | Zinc | 3.8 | 8 1/16 | 4 23/64 | 463.00 |
| STANDARD DUTY MODULAR DESIGN, 5-MICROMETRES FILTRATION | | | | | | | | | | | |
| TA753 | 1/2 | 85 | 150 | 0-125* | 125 | Manual | Polyurethane w/guard | 8.5 | 10 21/64 | 5 3/8 | 404.00 |
| TA754 | 1/2 | 85 | 150 | 0-125* | 125 | Auto | Polyurethane w/guard | 8.5 | 10 21/64 | 5 3/8 | 474.00 |
| TA755 | 1/2 | 85 | 250 | 0-125* | 150 | Manual | Zinc | 8.5 | 10 21/64 | 5 3/8 | 444.00 |
| TA756 | 1/2 | 85 | 175 | 0-125* | 125 | Auto | Zinc | 8.5 | 10 21/64 | 5 3/8 | 513.00 |
| TA757 | 3/4 | 85 | 150 | 0-125* | 125 | Manual | Polyurethane w/guard | 8.5 | 10 21/64 | 6 1/16 | 404.00 |
| TA758 | 3/4 | 85 | 150 | 0-125* | 125 | Auto | Polyurethane w/guard | 8.5 | 10 21/64 | 6 1/16 | 474.00 |
| TA759 | 3/4 | 85 | 250 | 0-125* | 150 | Manual | Zinc | 8.5 | 10 21/64 | 6 1/16 | 444.00 |
| TA760 | 3/4 | 85 | 175 | 0-125* | 125 | Auto | Zinc | 8.5 | 10 21/64 | 6 1/16 | 513.00 |

*Also available 0-25 PSI, 0-60 PSI, 0-250 PSI



Compact Design w/Polyurethane Bowl

TA743



Compact Design w/Polyurethane Bowl and Guard

TA745

FILTERS/REGULATORS (GAUGE INCLUDED)

- High-flow capacity reduces costly pressure drop
- Compact size allows greater design flexibility
- Lightweight construction for ease of installation

TOPRING

| Model No. | NPT Size" | Max SCFM @ 100 PSI | Max PSI | Reduced Pressure Range PSI | Max Temp. °F | Drain Type | Bowl Type | Bowl Cap. oz. | H" | W" | Price /Each |
|---|-----------|--------------------|---------|----------------------------|--------------|------------|----------------------|---------------|----------|---------|-------------|
| COMPACT MODULAR DESIGN, 5-MICROMETRES FILTRATION | | | | | | | | | | | |
| TA620 | 1/4 | 31 | 150 | 0-125 | 125 | Manual | Polyurethane | 1.5 | 7 1/16 | 1 19/32 | 128.00 |
| TA621 | 1/4 | 31 | 150 | 0-125 | 125 | Auto | Polyurethane | 1.5 | 7 1/16 | 1 19/32 | 139.00 |
| TA622 | 1/4 | 31 | 250 | 0-125 | 150 | Manual | Zinc | 1.5 | 7 1/16 | 1 19/32 | 140.00 |
| TA623 | 1/4 | 31 | 175 | 0-125 | 150 | Auto | Zinc | 1.5 | 7 1/16 | 1 19/32 | 148.00 |
| TA624 | 1/4 | 33 | 150 | 0-125 | 125 | Manual | Polyurethane w/Guard | 3.8 | 8 1/16 | 2 3/16 | 182.00 |
| TA625 | 1/4 | 33 | 150 | 0-125 | 125 | Auto | Polyurethane w/Guard | 3.8 | 8 1/16 | 2 3/16 | 214.00 |
| TA626 | 1/4 | 33 | 250 | 0-125 | 150 | Manual | Zinc | 3.8 | 8 1/16 | 2 3/16 | 201.00 |
| TA627 | 1/4 | 33 | 175 | 0-125 | 125 | Auto | Zinc | 3.8 | 8 1/16 | 2 3/16 | 242.00 |
| TA628 | 3/8 | 73 | 150 | 0-125 | 125 | Manual | Polyurethane w/Guard | 3.8 | 8 1/16 | 2 3/16 | 182.00 |
| TA629 | 3/8 | 73 | 150 | 0-125 | 125 | Auto | Polyurethane w/Guard | 3.8 | 8 1/16 | 2 3/16 | 214.00 |
| TA630 | 3/8 | 73 | 250 | 0-125 | 150 | Manual | Zinc | 3.8 | 8 1/16 | 2 3/16 | 201.00 |
| TA631 | 3/8 | 73 | 175 | 0-125 | 125 | Auto | Zinc | 3.8 | 8 1/16 | 2 3/16 | 242.00 |
| TA632 | 1/2 | 78 | 150 | 0-125 | 125 | Manual | Polyurethane w/Guard | 3.8 | 8 1/16 | 2 3/16 | 182.00 |
| TA633 | 1/2 | 78 | 150 | 0-125 | 125 | Auto | Polyurethane w/Guard | 3.8 | 8 1/16 | 2 3/16 | 214.00 |
| TA634 | 1/2 | 78 | 250 | 0-125 | 150 | Manual | Zinc | 3.8 | 8 1/16 | 2 3/16 | 201.00 |
| TA635 | 1/2 | 78 | 175 | 0-125 | 150 | Auto | Zinc | 3.8 | 8 1/16 | 2 3/16 | 242.00 |
| STANDARD DUTY MODULAR DESIGN, 5-MICROMETRES FILTRATION | | | | | | | | | | | |
| TA636 | 1/2 | 132 | 150 | 0-125* | 125 | Manual | Polyurethane w/guard | 8.5 | 10 21/64 | 2 11/16 | 228.00 |
| TA637 | 1/2 | 132 | 150 | 0-125* | 125 | Auto | Polyurethane w/guard | 8.5 | 10 21/64 | 2 11/16 | 263.00 |
| TA638 | 1/2 | 132 | 250 | 0-125* | 150 | Manual | Zinc | 8.5 | 10 21/64 | 2 11/16 | 254.00 |
| TA639 | 1/2 | 132 | 175 | 0-125* | 125 | Auto | Zinc | 8.5 | 10 21/64 | 2 11/16 | 316.00 |
| TA640 | 3/4 | 148 | 150 | 0-125* | 120 | Manual | Polyurethane w/guard | 8.5 | 10 21/64 | 3 1/32 | 228.00 |
| TA641 | 3/4 | 148 | 150 | 0-125* | 120 | Auto | Polyurethane w/guard | 8.5 | 10 21/64 | 3 1/32 | 263.00 |
| TA642 | 3/4 | 148 | 250 | 0-125* | 150 | Manual | Zinc | 8.5 | 10 21/64 | 3 1/32 | 254.00 |
| TA643 | 3/4 | 148 | 175 | 0-125* | 125 | Auto | Zinc | 8.5 | 10 21/64 | 3 1/32 | 316.00 |

*Also available 0-25 PSI, 2-60 PSI, 2-250 PSI



FILTERS/REGULATORS & LUBRICATORS (GAUGE INCLUDED)

- High-flow capacity reduces costly pressure drop
- Compact size allows greater design flexibility
- Lightweight construction for ease of installation

TOPRING

| Model No. | NPT Size" | Max SCFM @ 100 PSI | Max PSI | Reduced Pressure Range PSI | Max Temp. °F | Drain Type | Bowl Type | Bowl Cap. oz. | H" | W" | Price /Each |
|---|-----------|--------------------|---------|----------------------------|--------------|------------|----------------------|---------------|----------|---------|-------------|
| COMPACT MODULAR DESIGN, 5-MICROMETRES FILTRATION | | | | | | | | | | | |
| TA719 | 1/4 | 31 | 150 | 0-125 | 125 | Manual | Polyurethane Plast | 1.5 | 7 1/16 | 3 3/16 | 220.00 |
| TA720 | 1/4 | 31 | 150 | 0-125 | 125 | Auto | Polyurethane Plast | 1.5 | 7 1/16 | 3 3/16 | 228.00 |
| TA723 | 1/4 | 38 | 150 | 0-125 | 125 | Manual | Polyurethane w/guard | 3.8 | 8 1/16 | 4 23/64 | 283.00 |
| TA724 | 1/4 | 38 | 150 | 0-125 | 125 | Auto | Polyurethane w/guard | 3.8 | 8 1/16 | 4 23/64 | 314.00 |
| TA727 | 3/8 | 73 | 150 | 0-125 | 125 | Manual | Polyurethane w/guard | 3.8 | 8 1/16 | 4 23/64 | 283.00 |
| TA728 | 3/8 | 73 | 150 | 0-125 | 125 | Auto | Polyurethane w/guard | 3.8 | 8 1/16 | 4 23/64 | 314.00 |
| TA731 | 1/2 | 78 | 150 | 0-125 | 125 | Manual | Polyurethane w/guard | 3.8 | 8 1/16 | 4 23/64 | 283.00 |
| TA732 | 1/2 | 78 | 150 | 0-125 | 125 | Auto | Polyurethane w/guard | 3.8 | 8 1/16 | 4 23/64 | 314.00 |
| TA733 | 1/2 | 78 | 250 | 0-125 | 150 | Manual | Zinc | 3.8 | 8 1/16 | 4 23/64 | 320.00 |
| STANDARD DUTY MODULAR DESIGN, 5-MICROMETRES FILTRATION | | | | | | | | | | | |
| TA735 | 1/2 | 110 | 150 | 0-125* | 125 | Manual | Polyurethane w/guard | 8.5 | 10 21/64 | 5 3/8 | 338.00 |
| TA736 | 1/2 | 110 | 150 | 0-125* | 125 | Auto | Polyurethane w/guard | 8.5 | 10 21/64 | 5 3/8 | 382.00 |
| TA739 | 3/4 | 125 | 150 | 0-125* | 125 | Manual | Polyurethane w/guard | 8.5 | 10 21/64 | 6 1/16 | 343.00 |
| TA740 | 3/4 | 125 | 150 | 0-125* | 125 | Auto | Polyurethane w/guard | 8.5 | 10 21/64 | 6 1/16 | 387.00 |

*Also available 0-25 PSI, 0-60 PSI, 0-250 PSI



TA719

COMPRESSOR ACCESSORIES

FILTERS

- High flow capacity reduces costly pressure drop
- Compact size allows greater design flexibility
- Lightweight for ease of installation

TOPRING

| Model No. | NPT Size" | Max SCFM @ 100 PSI | Max PSI | Max Temp.°F | Drain Type | Bowl Type | Bowl Cap. oz. | H" | W" | Price /Each |
|---|-----------|--------------------|---------|-------------|------------|----------------------|---------------|---------|---------|-------------|
| MINI MODULAR DESIGN, 5-MICROMETRES FILTRATION | | | | | | | | | | |
| TA590 | 1/4 | 31 | 150 | 125 | Manual | Polyurethane | 1.5 | 5 3/64 | 1 19/32 | 73.10 |
| TA591 | 1/4 | 31 | 150 | 125 | Auto | Polyurethane | 1.5 | 5 3/64 | 1 19/32 | 82.50 |
| TA592 | 1/4 | 31 | 250 | 150 | Manual | Zinc | 1.5 | 5 3/64 | 1 19/32 | 83.50 |
| TA593 | 1/4 | 31 | 175 | 150 | Auto | Zinc | 1.5 | 5 3/64 | 1 19/32 | 92.80 |
| COMPACT MODULAR DESIGN, 5-MICROMETRES FILTRATION | | | | | | | | | | |
| TA594 | 1/4 | 42 | 150 | 125 | Manual | Polyurethane w/guard | 3.8 | 6 3/16 | 2 3/16 | 108.00 |
| TA595 | 1/4 | 42 | 150 | 125 | Auto | Polyurethane w/guard | 3.8 | 6 3/16 | 2 3/16 | 156.00 |
| TA598 | 3/8 | 64 | 150 | 125 | Manual | Polyurethane w/guard | 3.8 | 6 3/16 | 2 3/16 | 108.00 |
| TA599 | 3/8 | 64 | 150 | 125 | Auto | Polyurethane w/guard | 3.8 | 6 3/16 | 2 3/16 | 156.00 |
| TA602 | 1/2 | 68 | 150 | 125 | Manual | Polyurethane w/guard | 3.8 | 6 3/16 | 2 3/16 | 108.00 |
| TA603 | 1/2 | 68 | 150 | 125 | Auto | Polyurethane w/guard | 3.8 | 6 3/16 | 2 3/16 | 156.00 |
| STANDARD DUTY MODULAR DESIGN, 5-MICROMETRES FILTRATION | | | | | | | | | | |
| TA606 | 1/2 | 115 | 150 | 125 | Manual | Polyurethane w/guard | 8.5 | 7 63/64 | 2 11/16 | 142.00 |
| TA607 | 1/2 | 115 | 150 | 125 | Auto | Polyurethane w/guard | 8.5 | 7 63/64 | 2 11/16 | 183.00 |
| TA610 | 3/4 | 148 | 150 | 125 | Manual | Polyurethane w/guard | 8.5 | 7 63/64 | 3 1/32 | 142.00 |
| TA611 | 3/4 | 148 | 150 | 125 | Auto | Polyurethane w/guard | 8.5 | 7 63/64 | 3 1/32 | 189.00 |
| HEAVY-DUTY, 40-MICROMETRES FILTRATION | | | | | | | | | | |
| TA614 | 1 | 240 | 250 | 150 | Manual | Zinc | 16 | 8 23/32 | 4 1/16 | 312.00 |
| TA615 | 1 | 240 | 175 | 125 | Auto | Zinc | 16 | 8 23/32 | 4 1/16 | 355.00 |
| TA616 | 1 1/2 | 450 | 250 | 150 | Manual | Zinc | 16 | 9 29/64 | 5 3/16 | 352.00 |
| TA617 | 1 1/2 | 450 | 175 | 125 | Auto | Zinc | 16 | 9 29/64 | 5 3/16 | 394.00 |
| TA618 | 2 | 1200 | 250 | 150 | Manual | Zinc | 16 | 13 1/32 | 6 3/16 | 951.00 |
| TA619 | 2 | 1200 | 175 | 125 | Auto | Zinc | 16 | 13 1/32 | 6 3/16 | 992.00 |



Mini Design
w/Polyurethane Bowl
TA590



Compact Design w/
Polyurethane
TA594



Heavy-Duty
Design
w/Zinc Bowl
TA614

COALESCING FILTERS

Highly efficient filters designed for applications requiring the removal of all solid particles greater than 0.01 micron, together with 99.999% of the oil and water aerosols.

TOPRING

| Model No. | NPT Size" | Max SCFM @ 100 PSI | Max PSI | Max Temp.°F | Drain Type | Bowl Type | Bowl Cap. oz. | H" | W" | Price /Each |
|--|-----------|--------------------|---------|-------------|------------|----------------------|---------------|---------|---------|-------------|
| COMPACT MODULAR DESIGN, 0.01-MICROMETRES FILTRATION | | | | | | | | | | |
| TA765 | 1/4 | 20 | 150 | 125 | Manual | Polyurethane | 1.5 | 5 3/64 | 1 19/32 | 125.00 |
| TA766 | 1/4 | 20 | 150 | 125 | Auto | Polyurethane | 1.5 | 5 3/64 | 1 19/32 | 136.00 |
| TA767 | 1/4 | 20 | 250 | 150 | Manual | Zinc | 1.5 | 5 3/64 | 1 19/32 | 138.00 |
| TA769 | 1/4 | 43 | 150 | 125 | Manual | Polyurethane w/guard | 3.8 | 6 3/16 | 2 3/16 | 195.00 |
| TA770 | 1/4 | 43 | 150 | 125 | Auto | Polyurethane w/guard | 3.8 | 6 3/16 | 2 3/16 | 245.00 |
| TA771 | 1/4 | 43 | 250 | 150 | Manual | Zinc | 3.8 | 6 3/16 | 2 3/16 | 210.00 |
| TA772 | 1/4 | 43 | 175 | 125 | Auto | Zinc | 3.8 | 6 3/16 | 2 3/16 | 259.00 |
| TA777 | 3/8 | 43 | 150 | 125 | Manual | Polyurethane w/guard | 3.8 | 6 3/16 | 2 3/16 | 195.00 |
| TA778 | 3/8 | 43 | 150 | 125 | Auto | Polyurethane w/guard | 3.8 | 6 3/16 | 2 3/16 | 245.00 |
| TA779 | 3/8 | 43 | 250 | 150 | Manual | Zinc | 3.8 | 6 3/16 | 2 3/16 | 210.00 |
| TA780 | 3/8 | 43 | 175 | 125 | Auto | Zinc | 3.8 | 6 3/16 | 2 3/16 | 259.00 |
| TA773 | 1/2 | 43 | 150 | 125 | Manual | Polyurethane w/guard | 3.8 | 6 3/16 | 2 3/16 | 195.00 |
| TA774 | 1/2 | 43 | 150 | 125 | Auto | Polyurethane w/guard | 3.8 | 6 3/16 | 2 3/16 | 245.00 |
| TA775 | 1/2 | 43 | 250 | 150 | Manual | Zinc | 3.8 | 6 3/16 | 2 3/16 | 210.00 |
| TA776 | 1/2 | 43 | 175 | 125 | Auto | Zinc | 3.8 | 6 3/16 | 2 3/16 | 259.00 |
| STANDARD DUTY MODULAR DESIGN, 0.01-MICROMETRES FILTRATION | | | | | | | | | | |
| TA781 | 1/2 | 85 | 150 | 125 | Manual | Polyurethane w/guard | 8.5 | 7 63/64 | 2 11/16 | 215.00 |
| TA782 | 1/2 | 85 | 150 | 125 | Auto | Polyurethane w/guard | 8.5 | 7 63/64 | 2 11/16 | 263.00 |
| TA783 | 1/2 | 85 | 250 | 150 | Manual | Zinc | 8.5 | 7 63/64 | 2 11/16 | 242.00 |
| TA784 | 1/2 | 85 | 175 | 125 | Auto | Zinc | 8.5 | 7 63/64 | 2 11/16 | 296.00 |
| TA785 | 3/4 | 85 | 150 | 125 | Manual | Polyurethane w/guard | 8.5 | 7 63/64 | 3 1/32 | 218.00 |
| TA786 | 3/4 | 85 | 150 | 125 | Auto | Polyurethane w/guard | 8.5 | 7 63/64 | 3 1/32 | 265.00 |
| TA787 | 3/4 | 85 | 250 | 150 | Manual | Zinc | 8.5 | 7 63/64 | 3 1/32 | 251.00 |
| TA788 | 3/4 | 85 | 175 | 125 | Auto | Zinc | 8.5 | 7 63/64 | 3 1/32 | 300.00 |



Compact Design
w/Polyurethane Bowl
TA765



Compact Design w/
Polyurethane
TA769

REGULATORS (GAUGE INCLUDED)

- High performance
- Compact design allows for greater design flexibility
- **Heavy-Duty:** High-capacity performance featuring rugged design for the most demanding applications

TOPRING

| Model No. | NPT Size" | Max SCFM @ 100 PSI | Max PSI | Reduced Pressure Range PSI | Max Temp. °F | Bowl Type | H" | W" | Price /Each |
|-------------------------------------|-----------|--------------------|---------|----------------------------|--------------|-----------|----------|---------|-------------|
| MINI MODULAR DESIGN | | | | | | | | | |
| TA644 | 1/4 | 40 | 300 | 0-125 | 125 | Zinc | 4 3/32 | 1 19/32 | 83.50 |
| TA645 | 1/4 | 40 | 300 | 0-125(Non-Rel) | 125 | Zinc | 4 3/32 | 1 19/32 | 88.00 |
| TA646 | 1/4 | 40 | 300 | 0-25 | 125 | Zinc | 4 3/32 | 1 19/32 | 83.40 |
| TA647 | 1/4 | 40 | 300 | 0-60 | 125 | Zinc | 4 3/32 | 1 19/32 | 83.40 |
| COMPACT MODULAR DESIGN | | | | | | | | | |
| TA648 | 1/4 | 25 | 300 | 0-125 | 125 | Zinc | 4 9/64 | 2 3/16 | 109.00 |
| TA649 | 1/4 | 25 | 300 | 0-125(Non-Rel) | 125 | Zinc | 4 9/64 | 2 3/16 | 115.00 |
| TA650 | 1/4 | 25 | 300 | 0-25 | 125 | Zinc | 4 9/64 | 2 3/16 | 109.00 |
| TA651 | 1/4 | 25 | 300 | 0-60 | 125 | Zinc | 4 9/64 | 2 3/16 | 109.00 |
| TA652 | 3/8 | 45 | 300 | 0-125 | 125 | Zinc | 4 9/64 | 2 3/16 | 110.00 |
| TA655 | 3/8 | 45 | 300 | 0-60 | 125 | Zinc | 4 9/64 | 2 3/16 | 109.00 |
| TA656 | 1/2 | 60 | 300 | 0-125 | 125 | Zinc | 4 9/64 | 2 3/16 | 110.00 |
| STANDARD DUTY MODULAR DESIGN | | | | | | | | | |
| TA660 | 1/2 | 150 | 300 | 0-125* | 125 | Aluminum | 5 9/16 | 2 11/16 | 137.00 |
| TA661 | 1/2 | 150 | 300 | 0-125(Non-Rel)* | 125 | Aluminum | 5 9/16 | 2 11/16 | 148.00 |
| TA664 | 1/2 | 150 | 300 | 0-250* | 125 | Aluminum | 5 9/16 | 2 11/16 | 138.00 |
| TA665 | 3/4 | 150 | 300 | 0-125* | 125 | Aluminum | 5 9/16 | 3 1/32 | 139.00 |
| TA666 | 3/4 | 150 | 300 | 0-125(Non-Rel)* | 125 | Aluminum | 5 9/16 | 3 1/32 | 148.00 |
| TA669 | 3/4 | 150 | 300 | 0-250* | 125 | Aluminum | 5 9/16 | 3 1/32 | 138.00 |
| HEAVY-DUTY | | | | | | | | | |
| TA670 | 1 | 400 | 300 | 0-125** | 125 | Zinc | 10 7/16 | 4 11/16 | 234.00 |
| TZ028 | 1 1/4 | 500 | 300 | 0-125** | 125 | Zinc | 10 11/32 | 4 15/16 | 308.00 |
| TA672 | 1 1/2 | 500 | 300 | 0-125** | 125 | Zinc | 10 11/32 | 4 15/16 | 308.00 |

*Also available 0-25 PSI, 0-60 PSI, 0-250 PSI **Also available 0-250 PSI



Mini
TA644



Medium Duty
TA648



Heavy-Duty
TA670

LUBRICATORS

- High performance over a wide flow range
- Fillable under pressure through fill port
- No need to depressurize or remove bowl

TOPRING

| Model No. | NPT Size" | Max SCFM @ 100 PSI | Max PSI | Max Temp. °F | Bowl Type | Bowl Cap. oz. | H" | W" | Price /Each |
|-------------------------------------|-----------|--------------------|---------|--------------|----------------------|---------------|---------|---------|-------------|
| MINI MODULAR DESIGN | | | | | | | | | |
| TA675 | 1/4 | 45 | 150 | 125 | Polyurethane | 1.5 | 5 3/4 | 1 19/32 | 102.00 |
| COMPACT MODULAR DESIGN | | | | | | | | | |
| TA677 | 1/4 | 15 | 150 | 125 | Polyurethane w/guard | 3.8 | 6 15/16 | 2 3/16 | 129.00 |
| TA679 | 3/8 | 80 | 150 | 125 | Polyurethane w/guard | 3.8 | 6 15/16 | 2 3/16 | 129.00 |
| TA681 | 1/2 | 80 | 150 | 125 | Polyurethane w/guard | 3.8 | 6 15/16 | 2 3/16 | 129.00 |
| STANDARD DUTY MODULAR DESIGN | | | | | | | | | |
| TA683 | 1/2 | 110 | 150 | 125 | Polyurethane w/guard | 8.5 | 8 9/16 | 2 11/16 | 154.00 |
| TA684 | 1/2 | 110 | 250 | 150 | Zinc | 8.5 | 8 9/16 | 2 11/16 | 183.00 |
| TA685 | 3/4 | 125 | 150 | 125 | Polyurethane w/guard | 8.5 | 8 9/16 | 3 1/32 | 159.00 |
| TA686 | 3/4 | 125 | 250 | 150 | Zinc | 8.5 | 8 9/16 | 3 1/32 | 182.00 |



Mini
w/Polyurethane Bowl
TA675



Standard w/Zinc
Bowl
TA684

AIR TOOL OIL

Air Tool Oil is specially formulated to preserve and maintain the internal seals and mechanisms present in most hand held air tools. Air Tool Oil lubricates under high pressure to fine tolerances and resists moisture induced corrosion, maximizing the service life and performance of your air tools. Air Tool Oil contains no silicone.

| Model No. | Container | Price /Each |
|-----------|-------------------|-------------|
| AA091 | 8-oz. poly bottle | 5.96 |
| AA090 | 4-litre jug | 52.80 |



AIR TOOL OIL

- Ideal for keeping pneumatic equipment operating longer with greater power and less down time
- Formulated using a quality base lubricant and a high-tech additive system
- 15-oz. bottle

Model No. AF107
Price/Each \$9.65



COMPRESSORS

1.6 CONTINUOUS HP, 4.5-GALLON ELECTRIC WHEELED PORTABLE COMPRESSORS

- Vertical stand feature allows a user to transport or store compressor in a vertical position
- 78 dBA (tested per ISO3477) operational noise level for a quieter work environment
- 10" non-flat foam tires allow for easy transportation around the jobsite
- Oil free, maintenance free pump, for convenient use
- High flow coupler allows for maximum nailer performance
- Metal console panel provides gauges, couplers and regulators

Model No. TLV990 Mfg. No. D55146
Price/Each \$675.00

Horsepower: 1.6 HP
Tank Size: 4.5 Gal
Power Supply: 120V
CFM @ 100 PSI: 5.2
Max PSI: 175
Dimensions: 33.5" L x 23" W x 15" H
Weight: 83 lbs.



0.3 CONTINUOUS HP 1-GALLON SINGLE TANK HAND CARRY COMPRESSORS

- 0.75 SCFM delivered @ 90 PSI pump, 1.0 gallon tank and 135 max PSI enables more nails to be fired and provides quicker recovery
- Durable oil-free pump provides extended maintenance-free operation
- Low 71 dBA* allows for quieter operation (*Tested per ISO3744)
- Roll cage and control panel provide protection to key compressor components
- Low 2.6 amp draw motor provides easy start-up and reduces breaker tripping
- Ball valve drain allows for quick and thorough tank draining
- One quick coupler to easily support 1 nailer
- High-flow regulator for increased performance

Model No. TJZ977 Mfg. No. D55140
Price/Each \$209.00

Drive: Belt drive
Horsepower: 0.3 continuous HP
Tank Size: 1.0 gal.
Power Supply: 120 V, 10 A, 60 Hz, universal motor
CFM @90 PSI: 0.75 CFM
Pump Speed: 2200 RPM
Dimensions: 19" L x 14.5" W x 9" H
Weight: 29 lbs.



HEAVY-DUTY 1.1 MAX HP 4-GALLON ELECTRIC HAND CARRY COMPRESSORS

- 4.5 CFM @ 100 PSI, enables speedy recovery
- Oil lubricated pump improves durability
- Dual soft start valves assist in cold weather start up
- 4 gallon twin stack tank design with proven acceptance in the market
- Cast iron cylinder enhances pump life

Model No. WK827 Mfg. No. D55153
Price/Each \$449.00

Drive: Direct drive
Horsepower: 1.1 Max HP
Tank Size: 4 gal.
Power Supply: 120 VAC, 15 A, 60 Hz, 2 pole induction motor
CFM @100 PSI: 4.5 CFM
Pump Speed: 3400 RPM
Dimensions: 18" L x 18 1/2" W x 16 3/4" H
Weight: 56.5 lbs.
Includes: DeWalt synthetic compressor oil, 2 universal quick couplers and pressure regulator



3 HP ELECTRIC AIR COMPRESSORS

- Oil lubricated for cooler operation and reduced noise
- High output cast iron pump, delivers maximum performance
- Designed especially for framing nailers
- Air pressure regulator enables adjustments of line pressure to tool
- Stores 50' of 3/8" air hose with handle folded or upright

Model No. TLZ557 Mfg. No. MAC5200
Price/Each \$469.00

Horsepower: 3.0 HP
Tank Size: 5.2 gal.
Power Supply: 120 V, 13.8 A,
CFM @90 PSI: 6.5 CFM
Max PSI: 140
Dimensions: 29" L x 19" W x 19 1/2" H
Weight: 88 lbs.
Includes: 1/4" quick coupler, air filter, compressor oil



2.5 HP ELECTRIC AIR COMPRESSORS

- Oil lubricated for cooler operation and reduced noise
- High output cast iron pump with large bore cylinder
- Low amp draw reduces incidences of tripped breakers and voltage drop that can cause premature motor failure
- Air pressure regulator enables adjustments of line pressure
- Roll cage construction to protect components

Model No. TLZ558 Mfg. No. MAC2400
Price/Each \$419.00

Horsepower: 2.5 HP
Tank Size: 2 x 2.1 gal.
Power Supply: 120 V, 12.3 A,
CFM @90 PSI: 4.2 CFM
Max PSI: 130
Dimensions: 19 3/8" L x 18 3/4" W x 18" H
Weight: 77 lbs.
Includes: 1/4" quick coupler, air filter, compressor oil



PORTABLE CONTRACTOR SERIES COMPRESSORS – OIL LUBE, DIRECT DRIVE

- For professional, farm, home and hobbyists
- Quiet running and low 1720 RPM pump
- Die cast aluminum pump with cast iron sleeves and stainless steel valves for longer life
- All electrical units draw 15 amps or under
- Manual reset for overload protection
- Includes: Regulator, pressure gauge, pressure switch with on/off, universal coupler, filter silencer with replacement element and pump oil
- Factory tested prior to shipment
- Not intended for commercial use
- CSA approved
- 1-year limited manufacturer's warranty

TFA008



TFA009



TFA010



| Model No. | Mfg. No. | Peak HP | Running HP @ 90 PSI | Actual FAD-CFM | | Voltage /Phase | Amp Draw @ 125 PSI | Tank Size (gal.) | Pump RPM | Dimensions | | | Wt. lbs. | Price /Each |
|-----------|----------|---------|---------------------|----------------|---------|----------------|--------------------|------------------|----------|------------|------|------|----------|-------------|
| | | | | 90 PSI | 125 PSI | | | | | L" | x W" | x H" | | |
| TFA008 | DD-1004 | 1 | 1 | 4.5 | 4 | 115 V/1 PH | 15 | 4 | 1720 | 16 | x 16 | x 23 | 65 | 469.00 |
| TFA009 | DD-1503 | 1.5 | 1.5 | 6 | 4.6 | 115 V/1 PH | 14 | 3.2 | 1720 | 22 | x 9 | x 23 | 55 | 424.00 |
| TFA010 | DD-2022B | 2 | 1.5 | 6 | 4.6 | 115 V/1 PH | 15 | 4 | 1720 | 21 | x 20 | x 20 | 80 | 487.00 |

KING CANADA INDUSTRIAL COMPRESSORS

- 2-cylinder cast iron single stage oil lubricated pump
- ASME registered tank and safety valve
- Large intake filters
- Pump with V-style design minimizes vibration, improves cooling and extends compressor life
- Portable units are equipped with 9 1/2" pneumatics wheels and front handle
- Gas units are equipped with a 4-stroke air cooled OHV Honda gas engine



TLV740



TLV742



TLV743



TLV744



TLV739



TLV741



| Model No. | Mfg. No. | Peak HP | Air Delivery CFM | | Max. PSI | Voltage/Phase | Tank Size (gal.) | Amp Draw Motor | Pump RPM | Wt. lbs. | Remarks | Price /Each |
|-----------|--------------|---------|------------------|--------|----------|----------------|------------------|----------------|----------|----------|-----------------|-------------|
| | | | 40 PSI | 90 PSI | | | | | | | | |
| TLV739 | KC-2051H1 | 5.5 | 7.6 | 6.0 | 150 | 120 V/1 PH | 20 | 15 | 3450 | 145 | Horizontal | 899.00 |
| TLV740 | KC-3124v1 | 5.5 | 7.6 | 6.0 | 150 | 120 V/1 PH | 24 | 15/7.5 | 3600 | 170 | Vertical | 977.00 |
| TLV742 | KC-6160v1 | 6.5 | 13.4 | 11.2 | 150 | 208/240 V/1 PH | 60 | 15 | 3450 | 260 | Vertical | 1108.00 |
| TLV743 | KC-5160V1 | 6.5 | 22.6 | 18.5 | 150 | 208/240 V/1 PH | 60 | 23 | 3450 | 280 | Vertical | 1741.00 |
| TLV744 | KC-7180V1-MS | 7.5 | 43.0 | 30.0 | 150 | 208/240 V/1 PH | 80 | 33 | 1800 | 510 | Vertical | 3957.00 |
| TLV741* | KC-5510G1 | 5.5 | 14.1 | 11.2 | 150 | 5.5 HP Gas | 10(2x5) | N/A | 3600 | 165 | Twin Horizontal | 1654.00 |

*Gas powered

COMPRESSORS

CONTRACTOR SERIES

- Direct drive units have splash lubricated pump with cast iron sleeve for longer life
- Belt drive units have durable cast iron pumps
- Splash type lubrication
- All cast iron pumps have steel valves for longer life
- Flywheels designed for excellent pump cooling
- Manual reset for overload protection
- Dual control-start/stop with pressure switch or constant speed operation for electric belt drive unit
- All gas units equipped with Honda® gas engines
- Idle-down throttle control for gas belt drive units
- All units are factory tested prior to shipment
- 1-year warranty



TFA011



TFA012



TFA017



TFA014



TFA016



TFA013

| Model No. | Mfg. No. | Peak HP | Running HP @ 90 PSI | Actual FAD-CFM | | Max. PSI | Voltage /Phase | Tank Size (gal.) | Noise Level dBA | Amp Draw @ 125 PSI | Pump RPM | Wt. lbs. | Remarks | Price /Each |
|-----------|-------------|---------|---------------------|----------------|---------|----------|----------------|------------------|-----------------|--------------------|----------|----------|------------------|-------------|
| | | | | 90 PSI | 125 PSI | | | | | | | | | |
| TFA011 | DP-2004V | 2 | 1.5 | 6.0 | 4.6 | 125 | 115 V/1 PH | 3.2 | 83 | 12 | 3450 | 55 | Pan-Cake | 549.00 |
| TFA012 | DP-2022H | 2 | 1.5 | 6.0 | 4.6 | 125 | 115 V/1 PH | 4 | 83 | 12 | 3450 | 65 | Twin-Stack | 549.00 |
| TLV736 | PUK-1508MDC | 1.5 | 1.5 | 6.6 | 6.0 | 125 | 115 V/1 PH | 8 | 70 | 15 | 1100 | 210 | Twin-Tank | 1025.00 |
| TFA013 | PUK-2008MDC | 2 | 2.0 | 9.5 | 8.0 | 125 | 115 V/1 PH | 8 | 70 | 22 | 900 | 200 | Twin-Tank | 1276.00 |
| TFA014 | PUK-5508G | 5.5 | 5.5 | 12.5 | 10.5 | 125 | 5.5 HP Gas | 8 | 90 Run/82 Idle | N/A | 1100 | 190 | Twin-Tank | 1663.00 |
| TFA015 | PUK-5520G | 5.5 | 5.5 | 12.5 | 10.5 | 125 | 5.5 HP Gas | 20 | 90 Run/82 Idle | N/A | 1100 | 190 | 20 gal. portable | 1862.00 |
| TFA016 | PUK-9008G | 9 | 9 | 20.6 | 17.6 | 125 | 9 HP Gas | 8 | 90 Run/82 Idle | N/A | 1100 | 250 | Twin-Tank | 2725.00 |
| TFA017 | TUE-8008GE | 8 | 8 | 15.6 | 12.5 | 175 | 8 HP Gas | 8 | 90 Run/82 Idle | N/A | 1100 | 250 | Electric Start | 3085.00 |

PROFESSIONAL SERIES

- Quiet operation
- All units are belt driven
- Durable cast iron pumps
- Splash type lubrication
- All cast iron pumps have steel valves for longer life
- Flywheels designed for excellent pump cooling
- Manual reset for overload protection
- Portable units equipped with built-in regulator, pressure gauges and on/off switch
- Fully assembled - require handle and wheel attachment
- All units are factory tested prior to shipment
- For professional and automotive applications
- 1-year warranty



TFA019



TFA023



TFA022



TFA021



TFA024



| Model No. | Mfg. No. | HP | Actual FAD-CFM | | Max. PSI | Voltage /Phase | Tank Size (gal.) | Noise Level dBA | Wt. lbs. | Remarks | Price /Each |
|-----------|-----------|-----|----------------|--------|----------|----------------|------------------|-----------------|----------|---------------------|-------------|
| | | | 40 PSI | 90 PSI | | | | | | | |
| TFA019 | PK-2008 | 2 | 4.0 | 3.2 | 125 | 115 V /1 PH | 8 | 80 | 90 | Horizontal-Portable | 619.00 |
| TFA020 | PK-3011 | 3 | 6.0 | 5.3 | 125 | 115 V/1 PH | 11 | 80 | 110 | Horizontal-Portable | 762.00 |
| TFA021 | PK-5020 | 5 | 7.8 | 6.4 | 125 | 115 V/1 PH | 20 | 70 | 150 | Horizontal-Portable | 957.00 |
| TFA022 | PK-5020VP | 5 | 7.8 | 6.4 | 125 | 115 V/1 PH | 20 | 70 | 150 | Vertical-Portable | 962.00 |
| TFA023 | PP-6060V | 3 | 12.5 | 11.0 | 125 | 230 V/1 PH | 60 | 75 | 300 | Vertical-15 A Motor | 1349.00 |
| TFA024 | PK-6560V | 3.5 | 20.0 | 18.0 | 125 | 230 V/1 PH | 60 | 75 | 330 | Electric Start | 1829.00 |

INDUSTRIAL SERIES

- Quiet operation
- Heavy-duty two-stage high efficient air compressors
- Durable cast iron pumps for performance and durability
- Splash type lubrication
- All cast iron pumps have steel valves for longer life
- Flywheels designed for excellent pump cooling
- All units are factory tested prior to shipment
- For commercial, automotive and industrial applications
- 2-year warranty



5 HP VERTICAL COMPRESSORS – TWO STAGE

| | | | |
|-----------------------|------------|--------------------------|--------|
| Mfg. No.: | TK-5080V | No. of cylinders: | 3 |
| CFM @ 100 PSI: | 19.4 | Pump RPM: | 960 |
| Max. PSI: | 175 | Noise Level: | 79 dBA |
| Tank Size: | 80 gallons | Wt. Lbs.: | 600 |

| Model No. | Mfg. No. | Voltage | Price/Each |
|-----------|--------------|---------------------|------------|
| TFA031 | TK-5080V-01M | 208-230 V - 1 phase | 3174.00 |
| TFA032 | TK-5080V-02M | 200-208 V - 3 phase | 3174.00 |
| TFA033 | TK-5080V-03M | 230-240 V - 3 phase | 3174.00 |
| TFA034 | TK-5080V-04M | 460-480 V - 3 phase | 3174.00 |
| TFA035 | TK-5080V-05M | 575-600 V - 3 phase | 3174.00 |

5 HP HORIZONTAL COMPRESSORS – TWO STAGE

| | | | |
|-----------------------|------------|--------------------------|--------|
| Mfg. No.: | TK-5080 | No. of cylinders: | 3 |
| CFM @ 100 PSI: | 19.4 | Pump RPM: | 960 |
| Max. PSI: | 175 | Noise Level: | 79 dBA |
| Tank Size: | 80 gallons | Wt. Lbs.: | 600 |

| Model No. | Mfg. No. | Voltage | Price/Each |
|-----------|-------------|---------------------|------------|
| TFA041 | TK-5080-01M | 208-230 V - 1 phase | 3174.00 |
| TFA042 | TK-5080-02M | 200-208 V - 3 phase | 3174.00 |
| TFA043 | TK-5080-03M | 230-240 V - 3 phase | 3174.00 |
| TFA044 | TK-5080-04M | 460-480 V - 3 phase | 3174.00 |
| TFA045 | TK-5080-05M | 575-600 V - 3 phase | 3174.00 |

7.5 HP VERTICAL COMPRESSORS – TWO STAGE

| | | | |
|-----------------------|------------|--------------------------|--------|
| Mfg. No.: | TK-7580V | No. of cylinders: | 2 |
| CFM @ 100 PSI: | 26.1 | Pump RPM: | 995 |
| Max. PSI: | 175 | Noise Level: | 78 dBA |
| Tank Size: | 80 gallons | Wt. Lbs.: | 650 |

| Model No. | Mfg. No. | Voltage | Price/Each |
|-----------|--------------|---------------------|------------|
| TFA051 | TK-7580V-01M | 208-230 V - 1 phase | 4289.00 |
| TFA052 | TK-7580V-02M | 200-208 V - 3 phase | 3957.00 |
| TFA053 | TK-7580V-03M | 230-240 V - 3 phase | 3957.00 |
| TFA054 | TK-7580V-04M | 460-480 V - 3 phase | 3957.00 |
| TFA055 | TK-7580V-05M | 575-600 V - 3 phase | 3957.00 |

7.5 HP HORIZONTAL COMPRESSORS – TWO STAGE

| | | | |
|-----------------------|------------|--------------------------|--------|
| Mfg. No.: | TK-7580 | No. of cylinders: | 2 |
| CFM @ 100 PSI: | 26.1 | Pump RPM: | 995 |
| Max. PSI: | 175 | Noise Level: | 78 dBA |
| Tank Size: | 80 gallons | Wt. Lbs.: | 650 |

| Model No. | Mfg. No. | Voltage | Price/Each |
|-----------|-------------|---------------------|------------|
| TFA061 | TK-7580-01M | 208-230 V - 1 phase | 4289.00 |
| TFA062 | TK-7580-02M | 200-208 V - 3 phase | 3957.00 |
| TFA063 | TK-7580-03M | 230-240 V - 3 phase | 3957.00 |
| TFA064 | TK-7580-04M | 460-480 V - 3 phase | 3957.00 |
| TFA065 | TK-7580-05M | 575-600 V - 3 phase | 3957.00 |

10 HP HORIZONTAL COMPRESSORS – TWO STAGE

| | | | |
|-----------------------|-------------|--------------------------|--------|
| Mfg. No.: | TK-100120 | No. of cylinders: | 3 |
| CFM @ 100 PSI: | 36.1 | Pump RPM: | 843 |
| Max. PSI: | 175 | Noise Level: | 80 dBA |
| Tank Size: | 120 gallons | Wt. Lbs.: | 950 |

| Model No. | Mfg. No. | Voltage | Price/Each |
|-----------|---------------|---------------------|------------|
| TFA070 | TK-100120-02M | 200-208 V - 3 phase | 4714.00 |
| TFA071 | TK-100120-03M | 230-240 V - 3 phase | 4714.00 |
| TFA072 | TK-100120-04M | 460-480 V - 3 phase | 4714.00 |
| TFA073 | TK-100120-05M | 575-600 V - 3 phase | 4714.00 |

15 HP HORIZONTAL COMPRESSORS – TWO STAGE

| | | | |
|-----------------------|-------------|--------------------------|--------|
| Mfg. No.: | TK-150120 | No. of cylinders: | 3 |
| CFM @ 100 PSI: | 52.3 | Pump RPM: | 668 |
| Max. PSI: | 175 | Noise Level: | 80 dBA |
| Tank Size: | 120 gallons | Wt. Lbs.: | 1100 |

| Model No. | Mfg. No. | Voltage | Price/Each |
|-----------|---------------|---------------------|------------|
| TFA078 | TK-150120-02M | 200-208 V - 3 phase | 6872.00 |
| TFA079 | TK-150120-03M | 230-240 V - 3 phase | 6872.00 |
| TFA080 | TK-150120-04M | 460-480 V - 3 phase | 6872.00 |
| TFA081 | TK-150120-05M | 575-600 V - 3 phase | 6872.00 |

20 HP HORIZONTAL COMPRESSORS – TWO STAGE

| | | | |
|-----------------------|-------------|--------------------------|--------|
| Mfg. No.: | TK-200120 | No. of cylinders: | 3 |
| CFM @ 100 PSI: | 70 | Pump RPM: | 890 |
| Max. PSI: | 175 | Noise Level: | 82 dBA |
| Tank Size: | 120 gallons | Wt. Lbs.: | 1160 |

| Model No. | Mfg. No. | Voltage | Price/Each |
|-----------|---------------|---------------------|------------|
| TFA086 | TK-200120-02M | 200-208 V - 3 phase | 7396.00 |
| TFA087 | TK-200120-03M | 230-240 V - 3 phase | 7396.00 |
| TFA088 | TK-200120-04M | 460-480 V - 3 phase | 7141.00 |
| TFA089 | TK-200120-05M | 575-600 V - 3 phase | 7141.00 |

25 HP HORIZONTAL COMPRESSORS – TWO STAGE

| | | | |
|-----------------------|-------------|--------------------------|--------|
| Mfg. No.: | TK-250240 | No. of cylinders: | 4 |
| CFM @ 100 PSI: | 87.7 | Pump RPM: | 542 |
| Max. PSI: | 175 | Noise Level: | 78 dBA |
| Tank Size: | 240 gallons | Wt. Lbs.: | 1500 |

| Model No. | Mfg. No. | Voltage | Price/Each |
|-----------|---------------|---------------------|------------|
| TFA094 | TK-250240-02M | 200-208 V - 3 phase | 12487.00 |
| TFA095 | TK-250240-03M | 230-240 V - 3 phase | 12487.00 |
| TFA096 | TK-250240-04M | 460-480 V - 3 phase | 11950.00 |
| TFA097 | TK-250240-05M | 575-600 V - 3 phase | 11950.00 |

30 HP HORIZONTAL COMPRESSORS – TWO STAGE

| | | | |
|-----------------------|-------------|--------------------------|--------|
| Mfg. No.: | TK-300240 | No. of cylinders: | 4 |
| CFM @ 100 PSI: | 100.8 | Pump RPM: | 650 |
| Max. PSI: | 175 | Noise Level: | 80 dBA |
| Tank Size: | 240 gallons | Wt. Lbs.: | 1500 |

| Model No. | Mfg. No. | Voltage | Price/Each |
|-----------|---------------|---------------------|------------|
| TFA102 | TK-300240-02M | 200-208 V - 3 phase | 12773.00 |
| TFA103 | TK-300240-03M | 230-240 V - 3 phase | 12773.00 |
| TFA104 | TK-300240-04M | 460-480 V - 3 phase | 12241.00 |
| TFA105 | TK-300240-05M | 575-600 V - 3 phase | 12241.00 |

11 HP GAS ENGINE COMPRESSORS

| | | | |
|-----------------------|------------|--------------------------|-------------------------------|
| Mfg. No.: | TUK-1130GE | No. of cylinders: | 3 |
| CFM @ 100 PSI: | 19.4 | Pump RPM: | 960 |
| Max. PSI: | 175 | Noise Level: | 90 dBA (run) 82 dBA (idle) |
| Tank Size: | 30 gallons | Wt. Lbs.: | 450 |

| Model No. | Price/Each |
|-----------|------------|
| TFA106 | 4186.00 |



8" DRILL PRESSES

- Spindle is supported by high quality ball bearings
- Switch located at the front of the machine for easy access
- Positive depth stop for quick and easy adjustment
- 45° tilting table for angular drilling
- Includes: 1/2" drill chuck and key



| | |
|-----------------------|------------------------|
| Model No. | TM197 |
| Mfg. No. | KC-108C |
| Chuck Size: | 1/2" |
| Speeds: | 5 (620-3100 RPM) |
| Table Size: | 6 1/2" x 6 1/2" |
| Spindle Taper: | #33 JT |
| Motor: | 2.5 A, 1 phase, 60 Hz |
| Voltage: | 110 V |
| Dimensions: | 6 3/4" x 16 1/2" x 23" |
| Weight: | 38 lbs. |
| Price/Each | \$132.00 |

10" DRILL PRESSES W/LASER

- Dual intersecting adjustable laser guides
- Spindle is supported by high quality ball bearings
- Switch located at the front of the machine for easy access
- Positive depth stop for quick and easy adjustment
- 45° tilting table for angular drilling
- Includes: 1/2" drill chuck and key



| | |
|-----------------------|---------------------------|
| Model No. | TBW135 |
| Mfg. No. | KC-110C |
| Chuck size: | 1/2" |
| Speeds: | 5 (570-3050 RPM) |
| Table size: | 7 3/4" x 7 3/4" |
| Spindle Taper: | #33 Jacobs |
| Motor: | 3.2 A, 1 phase, 60 Hz |
| Voltage: | 110 V |
| Dimensions: | 11" L x 18 1/2" W x 29" H |
| Weight: | 70 lbs. |
| Price/Each | \$206.00 |

13" FLOOR DRILL PRESSES W/LASER

- Spindle is supported by high quality ball bearings
- Cast-iron pulleys reduce vibrations
- Comes with non-slip rubber feed handles
- 45° tilting table for angular drilling
- Locking depth stop for accurate repetitive blind hole drilling
- Includes: 5/8" drill chuck, key and 4" vise
- Light socket incorporated into drill press head (standard light bulb not included)



| | |
|--------------------------------------|---------------------------------|
| Model No. | TM209 |
| Mfg. No. | KC-116FC |
| Chuck size: | 5/8" |
| Max. distance chuck to table: | 24" |
| Max. distance chuck to base: | 45 1/2" |
| Table size: | 12 13/16" |
| Speeds: | 16 (210-3670 RPM) |
| Spindle Taper: | #2 Morse |
| Motor: | 7.5 A, 1 phase, 60 Hz |
| Voltage: | 110 V |
| Dimensions: | 12 13/16" L x 25" W x 63 1/2" H |
| Weight: | 147 lbs. |
| Price/Each | \$436.00 |

13" DRILL PRESSES W/LASER

- Spindle is supported by high quality ball bearings
- Cast-iron pulleys reduces vibrations
- Comes with non-slip rubber feed handles
- 45° tilting table for angular drilling
- Locking depth stop for accurate repetitive blind hole drilling
- Includes: 5/8" drill chuck, key and 4" vise
- Light socket incorporated into drill press head (standard light bulb not included)



| | |
|--------------------------------------|-----------------------------|
| Model No. | BV666 |
| Mfg. No. | KC-116C |
| Chuck size: | 5/8" |
| Max. distance chuck to table: | 13 3/4" |
| Max. distance chuck to base: | 26" |
| Table size: | 12 13/16" |
| Speeds: | 16 (210-3670 RPM) |
| Spindle Taper: | #2 Morse |
| Motor: | 7.5 A, 1 phase, 60 Hz |
| Voltage: | 110 V |
| Dimensions: | 12 13/16" L x 25" W x 42" H |
| Weight: | 125 lbs. |
| Price/Each | \$396.00 |

15" FLOOR DRILL PRESSES W/LASER

- Spindle is supported by high quality ball bearings
- Cast-iron pulleys reduces vibrations
- Comes with non-slip rubber feed handles
- 45° tilting table for angular drilling
- Locking depth stop for accurate repetitive blind hole drilling
- Includes: 5/8" drill chuck, key and 4" vise
- Light socket incorporated into drill press head (standard light bulb not included)



| | |
|--------------------------------------|-------------------------------|
| Model No. | TM211 |
| Mfg. No. | KC-117FC |
| Chuck size: | 5/8" |
| Max. distance chuck to table: | 23" |
| Max. distance chuck to base: | 44 1/2" |
| Table size: | 13 5/8" |
| Speeds: | 16 (210-3670 RPM) |
| Spindle Taper: | #2 Morse |
| Motor: | 10.5 A, 1 phase, 60 Hz |
| Voltage: | 110 V |
| Dimensions: | 13 5/8" L x 25" W x 63 1/2" H |
| Weight: | 157 lbs. |
| Price/Each | \$571.00 |

17" FLOOR DRILL PRESSES

- Spindle is supported by high quality ball bearings
- Cast-iron pulleys reduces vibrations
- Comes with non-slip rubber feed handles
- Tilting table for angular drilling
- Light fixture incorporated into the head casting illuminates the work table (light bulb not included)
- Includes: 5/8" drill chuck and key



| | |
|-----------------------|---------------------------|
| Chuck size: | 5/8" |
| Speeds: | 16 (240-3400 RPM) |
| Table size: | 13 3/4" |
| Spindle Taper: | #2 Morse |
| Motor: | 12 A @ 110 V, 6 A @ 220 V |
| | 1 HP, 1 phase, 60 Hz |
| Voltage: | 110 V/220 V |
| Dimensions: | 13 3/4" L x 25" W x 64" H |
| Weight: | 185 lbs. |

w/o Safety Guard

| | |
|-------------------|-----------------|
| Model No. | TM213 |
| Mfg. No. | KC-118FC |
| Price/Each | \$752.00 |

w/Safety Guard

| | |
|-------------------|-----------------|
| Model No. | TMA036 |
| Mfg. No. | KM-118FC-(LS) |
| Price/Each | \$902.00 |

22" FLOOR DRILL PRESSES

- Spindle is supported by high quality ball bearings
- Cast-iron pulleys reduce vibrations
- Tilting table for angular drilling
- Light fixture incorporated into the head casting illuminates the work table (light bulb not included)
- Comes with non-slip rubber feed handles



| | |
|-----------------------|--------------------------------|
| Chuck size: | 3/4" |
| Speeds: | 12 (150-4200 RPM) |
| Table size: | 18 3/4" x 16 1/4" |
| Spindle Taper: | #4 Morse |
| Motor: | 1 HP, 1 phase, 60 Hz |
| | 12.5 A @ 110 V, 6.25 A @ 220 V |
| Voltage: | 110/220 V |
| Dimensions: | 18 3/4" L x 33" W x 69" H |
| Weight: | 360 lbs. |

w/o Safety Guard

| | |
|-------------------|------------------|
| Model No. | TM214 |
| Mfg. No. | KC-122FC |
| Price/Each | \$1323.00 |

w/Safety Guard

| | |
|-------------------|------------------|
| Model No. | TMA037 |
| Mfg. No. | KM-122FC-(LS) |
| Price/Each | \$1474.00 |

21" GEARHEAD DRILLING MACHINES

- 1.5 HP
- Spindle is equipped with four heavy-duty tapered roller bearings
- Forward and reverse switch
- Head tilts 90° to the left and 30° to the right
- Includes: 1/2" chuck with key, 3 1/2" angle vise and safety guard



| | |
|-----------------------|---------------------------|
| Model No. | TS208 |
| Mfg. No. | KC-40HS |
| Chuck size: | 1/2" |
| Speeds: | 6 (60-1500 RPM) |
| Table size: | 21 3/4" x 19 1/2" |
| Spindle Taper: | #3 Morse |
| Motor: | 1.5 HP, 11 A |
| Voltage: | 220 V, 1 phase, 60 Hz |
| Dimensions: | 21 1/4" L x 30" W x 78" H |
| Weight: | 575 lbs. |
| Price/Each | \$5224.00 |

DRILLING ACCESSORIES



| Model No. | Mfg. No. | Description | Price /Each |
|---------------|----------|--|-------------|
| TJZ763 | KM-116 | Drill press chuck safety guard for BV666 and TM209 | 22.50 |
| TMA035 | KM-117 | Drill press chuck safety guard for TS206 and TM211 | 22.50 |
| TJZ764 | KM-118 | Drill press chuck safety guard for TM213 | 25.50 |
| TJZ765 | KM-122 | Drill press chuck safety guard for TM214 | 25.50 |

DRILL CHUCKS

PLAIN BEARING CHUCKS

- For medium or heavy-duty portable, bench or floor-mounted power tools
- Exceptionally high accuracy, gripping power and durability
- Wide range of capacities for use on threaded and taper-mounted spindles
- Jaws treated to ensure thread life and high gripping surface hardness
- 1-piece sleeve

TAPER-MOUNTED – HEAVY-DUTY MODELS

- Fluted sleeve standard except model **TB844**, which is smooth and ground
- Models **TB839** and **TB846** are equipped with a positive drive slot
- Models **TB840** and **TB847** are equipped with a pin-type positive drive
- Model **TB844** is equipped with locking collar - 1 1/16-20 thread

| Model No. | Mfg. No. | Cap. Min." | Cap. Max." | Mount | Key No. | Price /Each |
|--------------|----------|------------|------------|-------|---------|---------------|
| TB838 | 3A | 0.125 | 0.625 | 3JT | K3 | 283.00 |
| TB839 | 3KD | 0.125 | 0.625 | 3JT | K3 | 376.00 |
| TB840 | 3PD | 0.125 | 0.625 | 3JT | K3 | 439.00 |
| TB841 | 34-02 | 0.040 | 0.500 | 2JT | K3 | 178.00 |
| TB842 | 34-06 | 0.040 | 0.500 | 6JT | K3 | 255.00 |
| TB002 | 34-33 | 0.040 | 0.500 | 33JT | K3 | 199.00 |
| TB844 | 34-33C | 0.040 | 0.500 | 33JT | K3C | 174.00 |
| TB845 | 36 | 0.180 | 0.800 | 3JT | K4 | 383.00 |



Taper-Mounted

TAPER-MOUNTED – MEDIUM-DUTY MODELS

- Fluted sleeve standard except models **TB848** and **TB849**, which are smooth and ground
- All series 33 Plain Bearing Chucks are hammer capable
- Model **TB855** is equipped with a positive drive slot

| Model No. | Mfg. No. | Capacity Min." | Capacity Max." | Mount | Key No. | Price /Each |
|--------------|----------|----------------|----------------|-----------------|---------|---------------|
| TB848 | 0 | 0.135 | 0.156 | 0JT | K0 | 156.00 |
| TB849 | 1A | 0.040 | 0.250 | 1JT | K1 | 137.00 |
| TB850 | 2A | 0.040 | 0.375 | 2JT | K2 | 186.00 |
| TB853 | 33 | 0.08 | 0.500 | 33JT | K32 | 191.00 |
| TB854 | 3326A | 0.08 | 0.500 | 0.6250 Straight | K32 | 246.00 |
| TB855 | 33KD | 0.08 | 0.500 | 33JT | K32 | 207.00 |

THREAD-MOUNTED – HEAVY-DUTY MODELS

- Fluted sleeve standard on all models

| Model No. | Mfg. No. | Cap. Min." | Cap. Max." | Mount | Key No. | Price /Each |
|--------------|----------|------------|------------|--------|---------|---------------|
| TB856 | 3B 5/8 | 0.125 | 0.625 | 5/8-16 | K3 | 285.00 |
| TB857 | 7BA 3/8 | 0.04 | 0.250 | 3/8-24 | K7 | 143.00 |
| TB859 | 3B 1/2 | 0.125 | 0.625 | 1/2-20 | K3 | 227.00 |
| TB860 | 36B3/4 | 0.188 | 0.800 | 3/4-16 | K4 | 431.00 |
| TB861 | 36B 5/8 | 0.188 | 0.800 | 5/8-16 | K4 | 459.00 |



Thread-Mounted

THREAD-MOUNTED – MEDIUM-DUTY MODELS

- Fluted sleeve standard except models **TB862**, **TB863** and **TB866**, which are smooth and ground

| Model No. | Mfg. No. | Capacity Min." | Capacity Max." | Mount | Key No. | Price /Each |
|--------------|------------|----------------|----------------|---------|---------|---------------|
| TB862 | 0B 5/16 | 0.0135 | 0.156 | 5/16-24 | K0 | 199.00 |
| TB863 | 1B3/8 | 0.040 | 0.250 | 3/8-24 | K1 | 139.00 |
| TB864 | 2BA 3/8 | 0.040 | 0.375 | 3/8-24 | K2 | 183.00 |
| TB865 | 41BA 3/8 | 0.040 | 0.375 | 3/8-24 | K30 | 77.30 |
| TB866 | 41BA 3/8-S | 0.040 | 0.375 | 3/8-24 | K30 | 149.00 |
| TB867 | 41BA 1/2 | 0.040 | 0.375 | 1/2-20 | K30 | 199.00 |
| TB868 | 33BA1/2 | 0.08 | 0.500 | 1/2-20 | K32 | 173.00 |
| TB869 | 33BA 3/8 | 0.08 | 0.500 | 3/8-24 | K32 | 183.00 |
| TB870 | 33BA 5/8 | 0.08 | 0.500 | 5/8-16 | K32 | 198.00 |

BALL BEARING CHUCKS

- For heavy-duty, close tolerance production drilling
- Fits jig borers, milling machines, lathes and radials
- Ball thrust bearings reduce friction
- Jaws are centre-ground for absolute straightness and alignment
- Jaws treated to ensure extended life and high gripping surface hardness
- 1-piece sleeve
- Fluted sleeve standard



| Model No. | Mfg. No. | Capacity Min." | Capacity Max." | Mount | Key No. | Price /Each |
|--------------|----------|----------------|----------------|-------|---------|---------------|
| TB832 | 8 1/2N | 0.040 | 0.250 | 2JT | K30 | 231.00 |
| TB833 | 11N | 0.040 | 0.375 | 2JT | K32 | 258.00 |
| TB834 | 14N | 0.040 | 0.500 | 3JT | K3 | 361.00 |
| TB835 | 16N | 0.125 | 0.625 | 3JT | K4 | 414.00 |
| TB836 | 18N | 0.125 | 0.750 | 4JT | K4 | 622.00 |
| TB837 | 20N | 0.375 | 1.000 | 5JT | K5 | 838.00 |

PORTABLE TOOL CHUCKS

- Hand-Tite™ keyless drill chucks
- Keyless operation
- Made from high performance materials
- Durable, long lasting performance
- Fits all variable speed corded and cordless portable drill



| Model No. | Mfg. No. | Capacity | Cap. Min. " | Cap. Max. " | Mount | Wt. lbs. | Price /Each |
|--------------|----------|--------------|-------------|-------------|----------|----------|--------------|
| TT566 | 30354 | 3/8" (10 mm) | 0.040 | 0.375 | 3/8 - 24 | 1/2 | 45.40 |
| TT567 | 31038D | 1/2" (13 mm) | 0.062 | 0.50 | 1/2 - 20 | 3/4 | 69.20 |
| TT568 | 31037D | 1/2" (13 mm) | 0.062 | 0.50 | 3/8 - 24 | 3/4 | 69.90 |

STAINLESS KEYED CHUCKS

- For special applications on either portable drills or stationary machine tools
- Mainly used in medical and chemical industries
- Resists chemical corrosion
- Reduces potential for hazardous sparking
- Minimises risk of ferrous contamination in sterile environment
- Stainless steel chucks available in both thread mounting and taper mounting
- **TBR876** and **TBR878** take **TLV651** key
- **TDR881**, **TDR877** and **TDR879** take **TLV652** key



| Model No. | Mfg. No. | Capacity Min." | Capacity Max." | Mount | Price /Each |
|---------------|----------|----------------|----------------|---------|---------------|
| TDR876 | 0M | 0.028 | 5/32 | #0 JT | 314.00 |
| TDR878 | 0BM 5/16 | 0.028 | 5/32 | 5/16-24 | 309.00 |
| TDR881 | 1M | 0.028 | 1/4 | #1 JT | 286.00 |
| TDR877 | 1BM 5/16 | 0.028 | 1/4 | 5/16-24 | 338.00 |
| TDR879 | 1BM 3/8 | 0.028 | 1/4 | 3/8-24 | 306.00 |

Jacobs®

TAPER CHUCK ARBORS

- Morse taper to Jacobs® taper
- Precision machined and ground to master gauges
- For use with custom tool and work holder designs
- For specialized machining applications



Jacobs®

| Model No. | Mfg. No. | Morse to Mfg. | Overall Length" | Price /Each |
|-----------|----------|----------------|-----------------|-------------|
| TB885 | A0101 | 1 Morse x 1JT | 3.38 | 35.80 |
| TB886 | A0102 | 1 Morse x 2JT | 3.59 | 42.30 |
| TB887 | A0106 | 1 Morse x 6JT | 3.72 | 46.20 |
| TB888 | A0133 | 1 Morse x 33JT | 3.72 | 38.90 |
| TB889 | A0201 | 2 Morse x 1JT | 3.94 | 39.90 |
| TB890 | A0202 | 2 Morse x 2JT | 4.16 | 32.60 |
| TB891 | A0203 | 2 Morse x 3JT | 4.50 | 32.10 |
| TB892 | A0204 | 2 Morse x 4JT | 4.94 | 41.30 |
| TB893 | A0206 | 2 Morse x 6JT | 4.28 | 43.80 |
| TB894 | A0233 | 2 Morse x 33JT | 4.28 | 32.60 |
| TB895 | A0301 | 3 Morse x 1JT | 4.69 | 41.70 |
| TB896 | A0302 | 3 Morse x 2JT | 4.94 | 45.50 |
| TB897 | A0303 | 3 Morse x 3JT | 5.27 | 43.30 |
| TB898 | A0304 | 3 Morse x 4JT | 5.70 | 51.10 |
| TB899 | A0305 | 3 Morse x 5JT | 5.94 | 59.80 |
| TB900 | A0306 | 3 Morse x 6JT | 5.06 | 45.50 |
| TB901 | A0333 | 3 Morse x 33JT | 5.06 | 44.10 |
| TB902 | A0402 | 4 Morse x 2JT | 5.91 | 79.90 |
| TB903 | A0403 | 4 Morse x 3JT | 6.25 | 68.10 |
| TB904 | A0404 | 4 Morse x 4JT | 6.69 | 69.90 |
| TB905 | A0405 | 4 Morse x 5JT | 6.91 | 98.30 |
| TB906 | A0406 | 4 Morse x 6JT | 6.03 | 71.50 |
| TB908 | A0503 | 5 Morse x 3JT | 7.50 | 146.00 |
| TB909 | A0504 | 5 Morse x 4JT | 7.94 | 145.00 |
| TB910 | A0505 | 5 Morse x 5JT | 8.16 | 143.00 |

KEY LEASHES

Key leashes for chuck keys.

Jacobs®

| Model No. | Mfg. No. | Fits Key No. | Price /Each |
|-----------|----------|------------------------|-------------|
| TB973 | 3685D | TB963, TB964 and TB970 | 6.64 |
| TB974 | 3686D | TB971, TB972 and TB966 | 6.64 |



CHUCK KEYS

These standard chuck keys are used for plain, ball-bearing and other chucks.

Jacobs®

| Model No. | Mfg. No. | Pilot Size" | Used on Mfg. | Price /Each |
|---------------------|----------|-------------|-----------------------|-------------|
| T-HANDLE | | | | |
| TB963 | K0 | 1/8 | 0 Series | 9.71 |
| TB964 | K1 | 5/32 | 1 Series | 6.86 |
| TB965 | K5 | 7/16 | 20N | 42.10 |
| THUMB HANDLE | | | | |
| TB966 | K2 | 1/4 | 2 Series | 14.50 |
| TB967 | K3 | 5/16 | 3, 34 Series and 14N | 11.40 |
| TB968 | K3C | 5/16 | 34-33C | 13.90 |
| TB969 | K4 | 3/8 | 36, 16, 18N | 18.90 |
| TB971 | K30 | 15/64 | 31 Series and 8 1/2N | 9.32 |
| TB972 | K32 | 1/4 | 32, 33 Series and 11N | 9.85 |



KEY-BAK® CHUCK KEY RETRACTORS

- 24" stainless steel chain
- Chrome texture finish
- Fastens directly to the side of the drill press
- Never misplace your chuck key again

Model No. TL2012
Mfg. No. #7LSC
Price/Each \$17.40

KEY-BAK



DRILL SLEEVES & EXTENSION SOCKETS

Jacobs®

DRILL SLEEVES - MORSE TAPER ARCHER® SERIES 600

- Drill sleeves adapt Morse taper shank tools to larger machine spindles
- Oil toughened and externally precision ground with hardened tang



| Model No. | Mfg. No. | Morse Taper No. | | Length" | Price /Each |
|-----------|----------|-----------------|--------|---------|-------------|
| | | Outside | Inside | | |
| TB911 | 610 | 1 | 0 | 3.125 | 27.70 |
| TB912 | 621 | 2 | 1 | 3.62 | 22.60 |
| TB913 | 632 | 3 | 2 | 4.38 | 28.20 |
| TB914 | 631 | 3 | 1 | 3.88 | 28.20 |
| TB915 | 643 | 4 | 3 | 5.50 | 41.40 |
| TB916 | 642 | 4 | 2 | 4.88 | 41.50 |
| TB917 | 641 | 4 | 1 | 4.88 | 41.50 |
| TB918 | 651 | 5 | 1 | 6.12 | 72.00 |
| TB919 | 654 | 5 | 4 | 6.69 | 85.10 |
| TB920 | 653 | 5 | 3 | 6.12 | 76.50 |
| TB921 | 652 | 5 | 2 | 6.12 | 79.90 |
| TB922 | 664 | 6 | 4 | 8.56 | 198.00 |
| TB923 | 665 | 6 | 5 | 8.56 | 199.00 |

EXTENDED SOCKETS - MORSE TAPER ARCHER® SERIES 800

Extended sockets extend tool lengths and application distances while adapting for increases or decreases in applied tool Morse taper sizes.

These extension sockets are externally precision ground with hardened tang.



| Model No. | Mfg. No. | Morse Taper No. | | Length" | Price /Each |
|-----------|----------|-----------------|--------|---------|-------------|
| | | Outside | Inside | | |
| TB937 | 811 | 1 | 1 | 5.71 | 48.70 |
| TB938 | 812 | 1 | 2 | 6.30 | 54.00 |
| TB939 | 821 | 2 | 1 | 6.30 | 48.70 |
| TB940 | 822 | 2 | 2 | 6.89 | 77.90 |
| TB941 | 823 | 2 | 3 | 7.72 | 94.50 |
| TB942 | 831 | 3 | 1 | 6.89 | 56.20 |
| TB943 | 832 | 3 | 2 | 7.64 | 77.90 |
| TB944 | 833 | 3 | 3 | 8.46 | 99.30 |
| TB945 | 834 | 3 | 4 | 9.45 | 153.00 |
| TB946 | 842 | 4 | 2 | 8.46 | 89.10 |
| TB947 | 843 | 4 | 3 | 9.45 | 99.60 |
| TB948 | 844 | 4 | 4 | 10.43 | 159.00 |
| TB949 | 845 | 4 | 5 | 11.81 | 288.00 |
| TB950 | 853 | 5 | 3 | 10.35 | 132.00 |
| TB951 | 854 | 5 | 4 | 11.81 | 159.00 |
| TB952 | 855 | 5 | 5 | 13.19 | 289.00 |

EJECTING DRIFTS

These drifts eject Morse taper sizes 0 through 6 from sleeves, sockets and machine spindles.

Jacobs®



| Model No. | Mfg. No. | For Ejection of | Price /Each |
|-----------|----------|-------------------------|-------------|
| TB954 | 902 | Nos. 1 & 2 Morse Tapers | 17.90 |
| TB955 | 903 | Nos. 3 & 4 Morse Tapers | 21.90 |
| TB956 | 904 | Nos. 4 & 5 Morse Tapers | 32.40 |
| TB957 | 906 | No. 6 Morse Taper | 65.30 |

WEDGE SETS

For removing taper mount chucks from arbors or chucks.

| Model No. | Set No. | Used on Mfg. Taper No. | Price /Each |
|-----------|--------------|------------------------|-------------|
| TB959 | #1 Wedge Set | 1JT | 22.90 |
| TB960 | #2 Wedge Set | 2JT | 22.90 |
| TB961 | #3 Wedge Set | 3JT | 22.90 |
| TB962 | #6 Wedge Set | 6JT and 33JT | 22.90 |

Note: Removal of Jacobs® tapers no. 4 and no. 5 requires stacking of no. 3 and no. 6 wedge sets.



BENCH GRINDERS

6" BENCH GRINDERS

- 3.5 A, 110 V, single phase
- Wheel diameter: 6"
- 3500 RPM
- Weight: 18 lbs.
- Includes: Adjustable tool rests, removable wheel covers, plastic eye shields and medium and coarse grinding wheels

Model No. BT354
Mfg. No. KC-690
Price/Each \$70.70



6" BENCH GRINDERS WITH LAMP

- 3.5 A, 110 V, single phase
- Wheel diameter: 6"
- 3500 RPM
- Weight: 19 lbs.
- Includes: Adjustable tool rests, removable wheel covers, plastic eye shields and medium, coarse grinding wheels and work light

Model No. TG113
Mfg. No. KC-690L
Price/Each \$85.70



8" BENCH GRINDERS

- 7 A, 110 V, single phase
- Wheel diameter: 8"
- 3450 RPM
- Weight: 36 lbs.
- Includes: Adjustable tool rests, removable wheel covers, plastic eye shields and medium and coarse grinding wheels

Model No. TM223
Mfg. No. KC-890
Price/Each \$132.00



6" BENCH GRINDERS

- Powerful 5/8 HP induction motor for heavy-duty grinding operations
- Motor runs at 3450 RPM for high speed material removal
- Industrial cast iron base and motor housing provide durability and prolong life
- Precision-machined aluminum tool rests allow the user to accurately position work
- Rear exhaust ports in wheel guards for smoother operation
- 12 1/2" distance between wheels for longer and larger grinding applications
- Includes: 36-grit wheel, 60-grit wheel, eye shields, spark deflectors, tool rests, adjusting wrench



Model No. VE369
Amps: 4.0 AC
Horsepower: 5/8 HP
No load speed: 3450 RPM
Wheel dia.: 6"
Price/Each \$169.00

Mfg. No. DW756
Spindle dia: 1/2"
Adjustable tool resets: Yes
Tool length: 15"
Tool weight: 28.5 lbs.

10" BENCH GRINDERS

- 14 A, 110 V, single phase
- Wheel diameter: 10"
- 1720 RPM
- Weight: 80 lbs.
- Includes: Removable wheel covers, plastic eye shields and medium and coarse grinding wheels

Model No. TZ815
Mfg. No. KC-1090
Price/Each \$376.00



BENCH GRINDER STANDS

- Made of cast iron with coolant reservoir
- 32 3/4" high

Model No. WK731
Mfg. No. SS-150
Price/Each \$87.20



12" HEAVY-DUTY BENCH GRINDERS WITH FLOOR STAND

- 1.5 HP direct drive motor
- Permanently lubricated double sealed motor bearings
- Robust cast-iron wheel guards and dust vents with 2-1/2" T-fitting adaptor for dust collection
- Heavy duty cast tool rests
- Large adjustable shatter resistant plastic eye shields
- Line interruption electro-mechanical switch needs a restart after a power failure
- Sturdy stand with cast-iron base and mounting plate with steel column, helps dampen vibration
- Comes complete with floor stand, built-in cast-iron quench tray, 36 grit and 60 grit 12" x 2" grinding wheels
- Wheel size: 12" x 2"
- Arbor size: 1-1/4"
- Working height (floor to tool rests): 37-1/2"
- Wheel distance (centre to centre): 21-3/4"
- Motor: 1.5 HP, 10 Amp.
- RPM: 1,800
- Voltage: 220V, 1 phase, 60 Hz

Model No. TMA030
Mfg. No. KC-1295
Price/Each \$1425.00



INDUSTRIAL BENCH GRINDERS

- Warranted for 3 full years these grinders are made for constant industrial use
- They are supplied with 8 ft. 3 wire cord, eyeshields and pressed tool rests and supports



| Model No. | Mfg. No. | Wheel Dia." | HP | Arbor" | RPM | Motor | Wt. lbs. | Price /Each |
|-----------|----------|-------------|-----|--------|------|------------|----------|-------------|
| TM148 | 612R | 6 x 3/4 | 1/3 | 1/2 | 3600 | 115 V/1 HP | 29 | 559.00 |
| TM154 | 712R | 7 x 1 | 1/2 | 5/8 | 3600 | 115 V/1 HP | 45 | 799.00 |

BENCH GRINDER ABRASIVES

BENCH GRINDING WHEELS

D x T x H: Diameter x Thickness x Hub Size

GEMINI

- Quality, grey aluminum oxide for metal general purpose applications and sharp, green silicon carbide for nonferrous applications
- Each wheel contains nested bushings, accommodates a wide variety of standard arbor sizes
- Economical prices; ideal for small job shops and numerous applications



NORTON

| Model No. | Mfg. No. | D" | x | T" | x | H" | Grade | Max RPM | Price /Each |
|--|----------|----|---|-------|---|-------|-------------|---------|-------------|
| ALUMINUM OXIDE WHEELS FOR STEEL APPLICATION | | | | | | | | | |
| NS320 | 36132 | 6 | x | 1/2 | x | 1 | Coarse | 4140 | 24.20 |
| NS321 | 36131 | 6 | x | 1/2 | x | 1 | Medium | 4140 | 24.20 |
| NS322 | 36133 | 6 | x | 1/2 | x | 1 | Fine | 4140 | 24.20 |
| NS323 | 37103 | 6 | x | 3/4 | x | 1 | Coarse | 4140 | 28.20 |
| NS324 | 37102 | 6 | x | 3/4 | x | 1 | Medium | 4140 | 28.20 |
| NS325 | 37101 | 6 | x | 3/4 | x | 1 | Fine | 4140 | 28.20 |
| NS326 | 37958 | 6 | x | 1 | x | 1 | Coarse | 3600 | 32.60 |
| NS327 | 37957 | 6 | x | 1 | x | 1 | Medium | 3600 | 32.60 |
| NS328 | 37100 | 6 | x | 1 | x | 1 | Fine | 3600 | 32.60 |
| NS329 | 42292 | 7 | x | 1 | x | 1 | Coarse | 3600 | 39.90 |
| NS330 | 42294 | 7 | x | 1 | x | 1 | Medium | 3600 | 39.90 |
| NS331 | 42295 | 7 | x | 1 | x | 1 | Fine | 3600 | 39.90 |
| NS332 | 42315 | 8 | x | 3/4 | x | 1 | Coarse | 3600 | 41.50 |
| NS333 | 42316 | 8 | x | 3/4 | x | 1 | Medium | 3600 | 41.50 |
| NS334 | 42317 | 8 | x | 3/4 | x | 1 | Fine | 3600 | 41.50 |
| NS335 | 44454 | 8 | x | 1 | x | 1 | Very coarse | 3600 | 48.90 |
| NS336 | 44449 | 8 | x | 1 | x | 1 | Coarse | 3600 | 48.90 |
| NS337 | 44448 | 8 | x | 1 | x | 1 | Medium | 3600 | 48.90 |
| NS338 | 44447 | 8 | x | 1 | x | 1 | Fine | 3600 | 48.90 |
| NS339 | 60788 | 10 | x | 1 | x | 1 | Very coarse | 2485 | 74.50 |
| NS340 | 60787 | 10 | x | 1 | x | 1 | Coarse | 2485 | 74.50 |
| NS341 | 60789 | 10 | x | 1 | x | 1 | Medium | 2485 | 74.50 |
| NS342 | 60350 | 10 | x | 1 | x | 1 | Fine | 2485 | 74.50 |
| NS343 | 61250 | 10 | x | 1 1/4 | x | 1 1/4 | Coarse | 2485 | 88.50 |
| NS344 | 61251 | 10 | x | 1 1/4 | x | 1 1/4 | Medium | 2485 | 88.50 |
| NS345 | 61393 | 10 | x | 1 1/2 | x | 1 1/4 | Coarse | 2485 | 102.00 |
| NS346 | 61395 | 10 | x | 1 1/2 | x | 1 1/4 | Medium | 2485 | 102.00 |
| NS347 | 63052 | 12 | x | 1 1/2 | x | 1 1/2 | Coarse | 2070 | 141.00 |
| NS348 | 63053 | 12 | x | 1 1/2 | x | 1 1/2 | Medium | 2070 | 141.00 |
| NS349 | 63054 | 12 | x | 2 | x | 1 1/2 | Very coarse | 2070 | 181.00 |
| NS350 | 63055 | 12 | x | 2 | x | 1 1/2 | Coarse | 2070 | 181.00 |
| NS351 | 63056 | 12 | x | 2 | x | 1 1/2 | Medium | 2070 | 181.00 |

SCOTCH-BRITE™ EXL DEBURRING WHEELS

Use to clean, finish, blend, deburr or polish all types of metals, composites and glass.



| Model No. | Grit | Finish | Size" | Max. RPM | Price /Each |
|-----------|------|--------|-------------|----------|-------------|
| BP694 | 8A | Medium | 6 x 1/2 x 1 | 6000 | 65.27 |
| BP695 | 8S | Fine | 6 x 1/2 x 1 | 6000 | 65.30 |
| BP696 | 9S | Fine | 6 x 1/2 x 1 | 6000 | 65.30 |
| BP690 | 8A | Medium | 6 x 1 x 1 | 6000 | 86.60 |
| BP692 | 8S | Fine | 6 x 1 x 1 | 6000 | 86.60 |
| BP693 | 9S | Fine | 6 x 1 x 1 | 6000 | 86.60 |
| BP701 | 8A | Medium | 8 x 1/2 x 3 | 4500 | 82.70 |
| BP703 | 9S | Fine | 8 x 1/2 x 3 | 4500 | 82.70 |
| BP697 | 8A | Medium | 8 x 1 x 3 | 4500 | 111.00 |
| BP698 | 8S | Fine | 8 x 1 x 3 | 4500 | 111.00 |
| BP700 | 9S | Fine | 8 x 1 x 3 | 4500 | 111.00 |

RADIAL BRISTLE BRUSHES

- Radial bristle brushes have the same characteristics as the other 3M bristle brushes, but come in a convenient 6" size bench grinders
- Each brush comes with its own adapter
- Radial bristle brushes take the place of conventional wire wheels, on bench grinders, for general maintenance and production work
- Nylon bristles eliminate dangerous flying wires

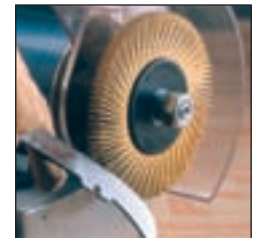

| Model No. | Size" | Grit | Colour | Max. RPM | Price /Each |
|-----------|-------|------|------------|----------|-------------|
| BP093 | 6 | 36X | Dark brown | 10 000 | 49.30 |
| BP094 | 6 | 50X | Green | 10 000 | 49.30 |
| BP095 | 6 | 80X | Yellow | 10 000 | 49.30 |

CRIMPED WIRE WHEEL BRUSHES

- Can be mounted horizontally or vertically
- Highly flexible, ideal for light to medium duty surface preparation on irregular surface
- Offered a variety of style from aggressive material removal to surface conditioning and polishing



NARROW FACE

- More flexible than the wide and medium style
- Can be mounted in multiples
- To be used with a straight grinder, a bench/pedestal grinder or a right angle grinder
- Application:** Deburring and cleaning narrow areas, producing antique finishes, rust and paint removal



| Brush Dia." | Arbor Hole" | Wire Gauge" | Trim Length" | Face Width" | Max RPM | Model No. | Price /Each |
|------------------|-------------|-------------|--------------|-------------|---------|-----------|-------------|
| STEEL | | | | | | | |
| 6 | 1 1/4 | 0.0104 | 1 1/8 | 5/8 | 6000 | BW882 | 23.40 |
| 8 | 1 1/4 | 0.014 | 1 1/2 | 5/8 | 4500 | BW886 | 39.10 |
| 10 | 1 1/4 | 0.014 | 2 1/2 | 5/8 | 3600 | BW888 | 51.20 |
| STAINLESS | | | | | | | |
| 6 | 1 1/4 | 0.0104 | 1 1/8 | 5/8 | 6000 | BW899 | 58.20 |
| 8 | 1 1/4 | 0.0104 | 3/4 | 1/2 | 4500 | BW900 | 70.10 |

SEE PAGES 941-943 FOR A WIDE VARIETY OF WIRE WHEEL BRUSHES

MEDIUM FACE

- Greater fill density and more aggressive brushing action
- Can be adaptable to multiple mounting for brushing wider areas
- To be used with a bench/pedestal grinder
- Application:** Edge blending, deburring, rust removal, surface finishing and cleaning



| Brush Dia." | Arbor Hole" | Wire Gauge" | Trim Length" | Face Width" | Max RPM | Model No. | Price /Each |
|------------------|-------------|-------------|--------------|-------------|---------|-----------|-------------|
| STEEL | | | | | | | |
| 6 | 2 | 0.0118 | 1 | 7/8 | 6000 | BW996 | 45.70 |
| 8 | 2 | 0.0118 | 1 1/2 | 5/8 | 4500 | BX006 | 64.70 |
| 10 | 2 | 0.0118 | 2 | 1 1/4 | 3600 | BX022 | 107.00 |
| STAINLESS | | | | | | | |
| 6 | 2 | 0.0118 | 1 | 7/8 | 6000 | BX040 | 78.80 |
| 8 | 2 | 0.0118 | 1 1/2 | 5/8 | 4500 | BX038 | 105.00 |

ANTI-VIBRATION

LEVELING MOUNTS

Self aligning leveling mounts compensate for uneven floors or mounting deflection. Made from oil resistant non-skid, ribbed neoprene rubber. VS series are used where maximum dampening of shock is required or to prevent creeping and walking of workshop machines.

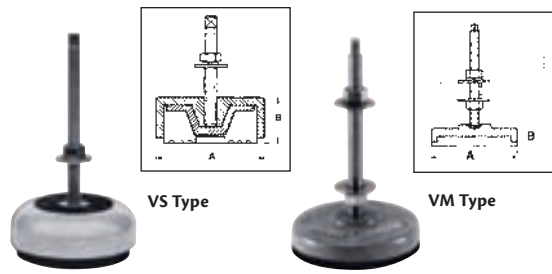

| Model No. | Type | Maximum Load in lbs. | | Leveling Adjustment" | Leveling Bolt Sizes" | | Mount Dimensions | | Price /Each |
|-----------|------|----------------------|--------|----------------------|----------------------|-----|------------------|--------|-------------|
| | | Non-Impact Machinery | Impact | | A" | B" | | | |
| UD172 | VM | 500 | 350 | 1.0 | 1/2NC x6 | 4.0 | 1 | 58.30 | |
| TP197 | VM | 1000 | 700 | 1.0 | 1/2NC x6 | 4.0 | 1 | 58.30 | |
| UA279 | VM | 2000 | 1400 | 1.0 | 5/8NC x8 | 4.0 | 1 | 64.20 | |
| UA278 | VM | 2000 | 1400 | 1.0 | 3/4NF x6 | 7.0 | 1 1/4 | 179.00 | |
| UA277 | VM | 4000 | 2800 | 1.0 | 3/4NF x6 | 7.0 | 1 1/4 | 179.00 | |
| UA276 | VM | 8000 | 5600 | 1.0 | 3/4NF x6 | 7.0 | 1 1/4 | 179.00 | |
| UA297 | VM | 12000 | 8500 | 1.0 | 1NS x8 | 7.0 | 1 1/4 | 190.00 | |
| UD170 | NVS | 1500 | 1000 | 1/2 | 1/2NC x6 | 3.5 | 1 1/2 | 80.20 | |
| UD171 | NVS | 4500 | 3000 | 1/2 | 5/8NC x8 | 5.5 | 2 | 175.00 | |
| UA290 | NVS | 15000 | 7000 | 1/2 | 1NS x8 | 9 | 2 1/4 | 350.00 | |
| UA289 | NVS | 15000 | 17000 | 1/2 | 1NS x8 | 9 | 2 1/4 | 350.00 | |

ANTI-VIBRATION CUPMOUNTS

Industrial cupmounts provide excellent protection against severe impact shock, vibration and noise

- High vibration dampening characteristics
- Fail-safe, rugged interlocking metal and neoprene construction provides exceptional performance against shear and compression forces and flexible vertically and stable horizontally
- Metal cupmount component is cold-rolled steel coupled with an elastomer-in-compression design
- High-grade neoprene elastomer provides resistance to oil and ozone
- Each side flange has through holes allowing for effective attachment to supporting equipment structure

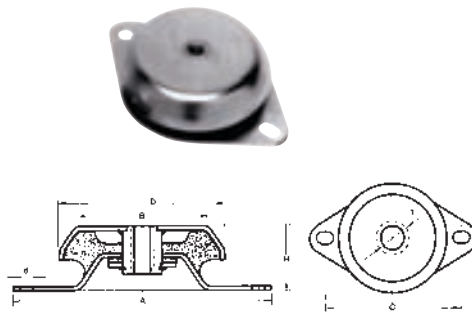

| Model No. | Maximum load in lbs. | | Mount Dimensions | | | | | Price /Each | | |
|-----------|----------------------|--------|------------------|-------|-------|--------|---------|-------------|----------|--------|
| | Non-impact Machinery | Impact | A" | B" | C" | D" | H" | | d" | T" |
| UD185 | 400 | 250 | 6 | 2 3/4 | 5 | 3 5/8 | 1 3/8 | 0.390 | 1/2 - 13 | 109.00 |
| UD186 | 700 | 450 | 6 | 2 3/4 | 5 | 3 5/8 | 1 3/8 | 0.390 | 1/2 - 13 | 109.00 |
| UD187 | 1400 | 900 | 7 11/16 | 4 | 6 3/8 | 5 3/16 | 1 11/16 | 0.550 | 5/8 - 11 | 147.00 |
| UD188 | 2600 | 1700 | 7 11/16 | 4 | 6 3/8 | 5 3/16 | 1 11/16 | 0.550 | 5/8 - 11 | 147.00 |

CYLINDRICAL VIBRATION ISOLATORS

- Natural rubber isolators can be used on all industrial motors, compressors, fans and machinery
- Not suitable for wall or ceiling mounting applications or with use in oil or solvent soaked environments

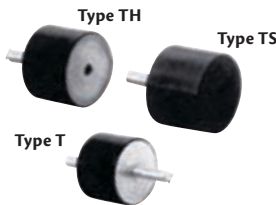

| Model No. | Type | Dimensions mm | | | | Load Cap. lbs. | Price /Each |
|-----------|------|---------------|----|------|----|----------------|-------------|
| | | A | B | C | D | | |
| UA280 | T | 20 | 15 | M-6 | 13 | 55 | 4.20 |
| UD167 | T | 20 | 25 | M-6 | 13 | 50 | 4.61 |
| UA282 | T | 25 | 30 | M-8 | 20 | 75 | 6.04 |
| UA283 | T | 30 | 30 | M-8 | 20 | 175 | 8.76 |
| UA284 | T | 35 | 35 | M-8 | 20 | 195 | 10.30 |
| UA285 | T | 40 | 30 | M-10 | 25 | 330 | 10.30 |
| UA286 | T | 40 | 40 | M-8 | 25 | 260 | 10.30 |
| UA287 | TH | 20 | 15 | M-6 | 13 | 55 | 4.20 |
| UA293 | TH | 25 | 25 | M-8 | 20 | 85 | 5.26 |
| UA294 | TH | 30 | 30 | M-8 | 20 | 175 | 6.79 |
| UA298 | TS | 20 | 15 | M-6 | 13 | 55 | 4.20 |
| UA299 | TS | 25 | 25 | M-8 | 20 | 85 | 5.26 |
| UA288 | TS | 30 | 30 | M-8 | 20 | 175 | 6.79 |
| UA300 | TS | 40 | 30 | M-10 | 25 | 330 | 9.84 |

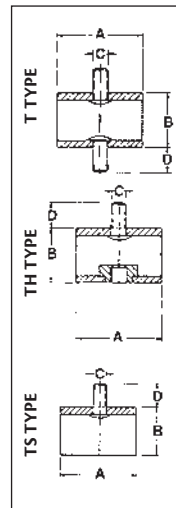

VIBRA-WEDGE ISOLATORS

- Designed for the installation and precision levelling of heavy industrial machinery
- 3 machined wedges are mounted and held together by a horizontal adjusting bolt
- A lock screw secures the mount in the levelled position
- A special opening allows for bolting of the machine to the floor

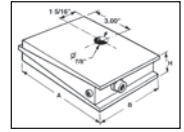

Note: Max. levelling is 1/4" (6 mm). If more height is required use a shim plate.

| Model No. | A mm | B mm | H mm | Max. Load lbs. | Price /Each |
|-----------|------|------|--------|----------------|-------------|
| UP587 | 150 | 100 | 40+/-5 | 15000 | 365.00 |
| UP588* | 150 | 100 | 50+/-5 | 9000 | 394.00 |

*Neoprene top and bottom included.

NEOPRENE VIBRATION PADS

Install machinery and equipment on double sided moulded neoprene pads to isolate vibration, shock and reduce noise level. Waffle design allows material expansion without losing stability. Pads should be cut to the size of machines feet allowing 1/2" margin on all sides. Pads resist oil and solvents.

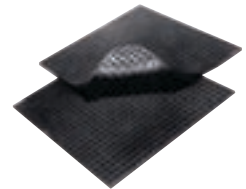

| Model No. | Load Range | Size" | Price /Each |
|-----------|-------------|----------------|-------------|
| UA295 | 1-25 PSI | 18 x 18 x 5/16 | 75.80 |
| UA291 | 10-50 PSI | 18 x 18 x 5/16 | 75.80 |
| UA270 | 40-100 PSI | 18 x 18 x 5/16 | 75.80 |
| UD168 | 75-200 PSI | 18 x 18 x 1/2 | 99.20 |
| UA292 | 150-300 PSI | 18 x 18 x 1/2 | 114.00 |
| UA273 | 1-25 PSI | 6 x 6 x 5/16 | 14.60 |
| UA271 | 10-50 PSI | 6 x 6 x 5/16 | 14.60 |
| UA275 | 40-100 PSI | 6 x 6 x 5/16 | 14.60 |
| UA274 | 75-200 PSI | 6 x 6 x 1/2 | 17.50 |
| UA296 | 150-300 PSI | 6 x 6 x 1/2 | 17.50 |

SLOTTED SHIMS

- Slotted shim is the best way to solve alignment and leveling problems
- Shims conform to standard bolt and stud sizes
- Each shim marked with thickness in decimal and metric
Thicknesses up to 0.010" are permanently etched
Thicknesses over 0.015" are permanently stamped
- 300 series stainless steel material resists rust and corrosion



SLOTTED SHIMS ASSORTMENTS

Full and mini assortments come in durable metal boxes.
Shop kits are packaged in a sturdy chipboard box

A. Full Assortment: Contains 260 Pcs. 20 each of 13 sizes (0.001", 0.002", 0.003", 0.004", 0.005", 0.010", 0.015", 0.020", 0.025", 0.050", 0.075", 0.100", 0.125")

B. Mini Assortment: Contains 130 Pcs., 10 each of 13 sizes (0.001", 0.002", 0.003", 0.004", 0.005", 0.010", 0.015", 0.020", 0.025", 0.050", 0.075", 0.100", 0.125")

C. Shop Kit: Contains 80 Pcs., 10 each of 8 sizes (0.001", 0.003", 0.005", 0.010", 0.015", 0.020", 0.025", 0.075")

ASSORTMENTS

| | 2" x 2" | | 3" x 3" | | 4" x 4" | | 5" x 5" | |
|----|-----------|-------------|-----------|-------------|-----------|-------------|-----------|-------------|
| | Model No. | Price /Each | Model No. | Price /Each | Model No. | Price /Each | Model No. | Price /Each |
| A. | GR264 | 909.00 | GR265 | 1142.00 | GR266 | 1653.00 | GR267 | 2412.00 |
| B. | GR268 | 520.00 | GR269 | 636.00 | GR270 | 906.00 | GR271 | 1273.00 |
| C. | GR272 | 200.00 | GR273 | 288.00 | GR274 | 449.00 | GR275 | 805.00 |

SLOTTED SHIMS INDIVIDUAL PACKAGES

| Thickness" | Pcs Per Pkg | Priced Per Package | | | | | | | | | |
|------------|-------------|--------------------|-------------|-----------|-------------|-----------|-------------|-----------|-------------|--|--|
| | | 2" x 2" | | 3" x 3" | | 4" x 4" | | 5" x 5" | | | |
| | | Model No. | Price /Each | Model No. | Price /Each | Model No. | Price /Each | Model No. | Price /Each | | |
| 0.001 | 20 | GR276 | 60.00 | GR289 | 71.90 | GR302 | 94.80 | GR315 | 126.00 | | |
| 0.002 | 20 | GR277 | 60.00 | GR290 | 71.90 | GR303 | 94.80 | GR316 | 126.00 | | |
| 0.003 | 20 | GR278 | 60.00 | GR291 | 71.90 | GR304 | 94.80 | GR317 | 126.00 | | |
| 0.004 | 20 | GR279 | 60.00 | GR292 | 71.90 | GR305 | 94.80 | GR318 | 126.00 | | |
| 0.005 | 20 | GR280 | 60.00 | GR293 | 71.90 | GR306 | 94.80 | GR319 | 126.00 | | |
| 0.010 | 20 | GR281 | 60.00 | GR294 | 71.90 | GR307 | 94.80 | GR320 | 126.00 | | |
| 0.015 | 10 | GR282 | 30.00 | GR295 | 36.00 | GR308 | 47.40 | GR321 | 62.90 | | |
| 0.020 | 10 | GR283 | 33.60 | GR296 | 36.00 | GR309 | 51.00 | GR322 | 71.90 | | |
| 0.025 | 10 | GR284 | 33.60 | GR297 | 36.00 | GR310 | 51.00 | GR323 | 71.90 | | |
| 0.050 | 5 | GR285 | 18.10 | GR298 | 22.50 | GR311 | 31.50 | GR324 | 47.90 | | |
| 0.075 | 5 | GR286 | 20.40 | GR299 | 30.00 | GR312 | 43.50 | GR325 | 68.20 | | |
| 0.100 | 5 | GR287 | 24.00 | GR300 | 33.80 | GR313 | 56.90 | GR326 | 91.50 | | |
| 0.125 | 5 | GR288 | 26.40 | GR301 | 37.50 | GR314 | 64.50 | GR327 | 104.00 | | |

SLOTTED SHIM SLOT SIZES

| 2" x 2" | 3" x 3" | 4" x 4" | 5" x 5" |
|---------|---------|---------|---------|
| 5/8" | 3/4" | 1 1/4" | 1 5/8" |

SLOTTED SHIM TOLERANCES

| Thickness" | Tolerance" |
|---------------|------------|
| 0.001 | ± 0.00008 |
| 0.002 | ± 0.0001 |
| 0.003 | ± 0.00015 |
| 0.004 | ± 0.0002 |
| 0.005 | ± 0.00025 |
| 0.010-0.020 | ± 0.0005 |
| 0.025 | ± 0.00075 |
| 0.05 | ± 0.001 |
| 0.075 & 0.100 | ± 0.002 |
| 0.125 | ± 0.0025 |

SHIM STOCK ROLLS & SHEETS

- Precision Brand steel shim stock is a full hard, cold rolled, low carbon 1010
- Rockwell hardness: RB90-100
- Approx. tensile strength: 80 000 PSI
- Meets ASTM A-109, AISI 1010

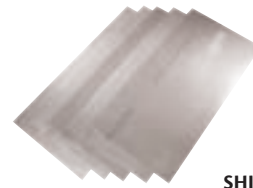

ROLLS (1 ROLL PER PKG.)

| Thickness" | STEEL 6" x 100" | | STAINLESS STEEL 6" x 50" | | BRASS 6" x 100" | |
|------------|--------------------|-------------|-----------------------------|-------------|--------------------|-------------|
| | Model No. | Price /Each | Model No. | Price /Each | Model No. | Price /Each |
| 0.0005 | - | - | GR350 | 147.00 | - | - |
| 0.0010 | GR328 | 21.00 | GR351 | 70.70 | GR367 | 40.80 |
| 0.0015 | GR329 | 25.50 | GR352 | 64.70 | GR368 | 41.00 |
| 0.0020 | GR330 | 14.40 | GR353 | 44.90 | GR369 | 42.30 |
| 0.0025 | GR331 | 15.30 | - | - | - | - |
| 0.0030 | GR332 | 18.40 | GR354 | 42.90 | - | - |
| 0.0035 | GR333 | 19.80 | - | - | - | - |
| 0.0040 | GR334 | 17.70 | GR355 | 41.90 | GR371 | 46.00 |
| 0.0050 | GR335 | 16.20 | GR356 | 48.20 | GR372 | 47.60 |
| 0.0060 | GR336 | 15.50 | GR357 | 48.10 | GR373 | 49.10 |
| 0.0070 | GR337 | 16.10 | GR358 | 49.70 | GR374 | 51.40 |
| 0.0080 | GR338 | 16.10 | GR359 | 50.50 | GR375 | 54.30 |
| 0.0090 | GR339 | 16.80 | GR360 | 56.80 | GR376 | 58.20 |
| 0.0100 | GR340 | 17.00 | GR361 | 52.30 | GR377 | 63.40 |
| 0.0120 | GR341 | 16.70 | GR362 | 54.70 | GR378 | 68.60 |
| 0.0135 | GR342 | 16.70 | - | - | - | - |
| 0.0150 | GR343 | 15.80 | GR363 | 59.20 | GR379 | 79.40 |
| 0.0165 | GR344 | 18.30 | - | - | - | - |
| 0.0180 | GR345 | 18.10 | - | - | GR380 | 91.60 |
| 0.0200 | GR346 | 17.90 | GR364 | 70.30 | GR381 | 89.60 |
| 0.0220 | GR347 | 18.80 | - | - | - | - |
| 0.0250 | GR348 | 19.30 | GR365 | 82.30 | GR382 | 107.00 |
| 0.0310 | GR349 | 20.30 | GR366 | 93.80 | GR383 | 128.00 |

SHEETS (10 SHEETS PER PKG.)

| Thickness" | STEEL 6" x 18" | | STAINLESS STEEL 6" x 25" | | BRASS 6" x 18" | |
|------------|-------------------|-------------|-----------------------------|-------------|-------------------|-------------|
| | Model No. | Price /Each | Model No. | Price /Each | Model No. | Price /Each |
| 0.0010 | GR384 | 81.50 | - | - | GR413 | 94.50 |
| 0.0015 | GR385 | 81.50 | - | - | GR414 | 94.50 |
| 0.0020 | GR386 | 52.60 | - | - | GR415 | 94.50 |
| 0.0025 | GR387 | 78.60 | - | - | - | - |
| 0.0030 | GR388 | 52.60 | - | - | GR416 | 94.50 |
| 0.0035 | GR389 | 75.70 | - | - | - | - |
| 0.0040 | GR390 | 55.00 | - | - | GR417 | 99.90 |
| 0.0050 | GR391 | 56.00 | - | - | GR418 | 114.00 |
| 0.0060 | GR392 | 60.40 | - | - | GR419 | 124.00 |
| 0.0070 | GR393 | 60.40 | - | - | GR420 | 139.00 |
| 0.0080 | GR394 | 61.90 | GR406* | 60.60 | GR421 | 139.00 |
| 0.0090 | GR395 | 61.90 | - | - | GR422 | 148.00 |
| 0.0100 | GR396 | 65.30 | GR407* | 62.80 | GR423 | 148.00 |
| 0.0120 | GR397 | 66.10 | GR408* | 65.60 | GR424 | 184.00 |
| 0.0135 | GR398 | 66.10 | - | - | - | - |
| 0.0150 | GR399 | 66.10 | GR409* | 71.00 | GR425 | 204.00 |
| 0.0165 | GR400 | 72.30 | - | - | - | - |
| 0.0180 | GR401 | 72.30 | - | - | GR426 | 228.00 |
| 0.0200 | GR402 | 78.30 | GR410* | 84.40 | - | - |
| 0.0220 | GR403 | 80.20 | - | - | - | - |
| 0.0250 | GR404 | 80.20 | GR411* | 98.80 | GR427 | 276.00 |
| 0.0310 | GR405 | 85.90 | GR412* | 113.00 | GR428 | 315.00 |

*Stainless Steel Sheets sold in pack of 2

SHIM TOLERANCES

| Thickness" | Tolerance" |
|------------------------|------------|
| STEEL | |
| 0.001 - 0.003 | ± 10% |
| 0.0035 - 0.006 | ± 0.0005 |
| 0.007 - 0.018 | ± 0.00075 |
| 0.020 - 0.025 | ± 0.001 |
| 0.031 | ± 0.0015 |
| Width Tolerance | ± 0.005 |
| STAINLESS STEEL | |
| 0.0005-0.010 | ± 10% |
| 0.011 - 0.019 | ± 0.001 |
| 0.020 - 0.028 | ± 0.0015 |
| 0.029 - 0.031 | ± 0.002 |
| Width Tolerance | ± 0.005 |
| BRASS | |
| 0.001 - 0.003 | ± 10% |
| 0.004 | ± 0.0003 |
| 0.005 - 0.006 | ± 0.0004 |
| 0.007 - 0.009 | ± 0.0006 |
| 0.010 - 0.013 | ± 0.0008 |
| 0.014 - 0.017 | ± 0.0010 |
| 0.018 - 0.021 | ± 0.0013 |
| 0.022 - 0.031 | ± 0.002 |
| Width Tolerance | ± 0.008 |

SHIM STOCK ASSORTMENTS

| Model No. | Type | Description | Price/Each |
|-------------------------------------|----------------------------------|---|------------|
| SHIM STOCK SHEET ASSORTMENTS | | | |
| GR431 | Stainless Steel Sheet Assortment | Contains 8 sheets 6" x 12", one sheet of each: 0.001", 0.002", 0.003", 0.005", 0.008", 0.010", 0.015", 0.020" | 165.00 |
| GR432 | Brass Sheet Assortment | Contains 12 sheets 6" x 18" one sheet of each: 0.001", 0.0015", 0.002", 0.003", 0.004", 0.005", 0.006", 0.007", 0.008", 0.010", 0.012", 0.015" | 160.00 |
| GR433 | Steel Sheet Assortment | Contains 12 sheets 6" x 18", one sheet of each: 0.001", 0.0015", 0.002", 0.003", 0.004", 0.005", 0.006", 0.007", 0.008", 0.010", 0.012", 0.015" | 87.10 |
| SHIM STOCK ROLL ASSORTMENTS | | | |
| GR429 | Steel Roll Assortment | Contains 4 rolls per assortment 6" x 50" (Includes one roll of each: 0.001", 0.002", 0.003", 0.005") | 62.00 |
| GR430 | Brass Roll Assortment | Contains 4 rolls per assortment 6" x 50" (Includes one roll of each: 0.001", 0.002", 0.003", 0.005") | 92.40 |

SHIMS & GAUGES

COLOUR-CODED PLASTIC SHIM STOCKS

- Precision Brand colour-coded shim is made from high quality plastic material
- Resist oil, easy to cut, minimal compression during use
- Thickness to industry standards
- Non conductive to electricity



PLASTIC SHIM STOCK COLOUR-CODED

| | | | | 5" x 20" | | 10" x 20" | |
|-------------------|--------|--------|--------------|--------------|----------------|--------------|----------------|
| Thickness Inch | cm | Colour | Qty. Pkg. | Model No. | Price /Each | Model No. | Price /Each |
| 0.0005 | 0.013 | Silver | 5 | GR434 | 34.50 | GR451 | 49.00 |
| 0.0010 | 0.0250 | Amber | 5 | GR435 | 34.50 | GR452 | 49.00 |
| 0.0015 | 0.0380 | Purple | 5 | GR436 | 34.50 | GR453 | 49.00 |
| 0.0020 | 0.0510 | Red | 5 | GR437 | 34.50 | GR454 | 49.00 |
| 0.0030 | 0.0760 | Green | 5 | GR438 | 34.50 | GR455 | 49.00 |
| 0.0040 | 0.1020 | Tan | 10 | GR439 | 74.20 | GR456 | 122.00 |
| 0.0050 | 0.1270 | Blue | 10 | GR440 | 74.20 | GR457 | 122.00 |
| 0.0075 | 0.1910 | Matte | 10 | GR441 | 74.20 | GR458 | 122.00 |
| 0.0100 | 0.2540 | Brown | 10 | GR442 | 79.50 | GR459 | 146.00 |
| 0.0125 | 0.3180 | Black | 10 | GR443 | 79.50 | GR460 | 146.00 |
| 0.0150 | 0.3810 | Pink | 10 | GR444 | 79.50 | GR461 | 146.00 |
| 0.0200 | 0.5080 | Yellow | 10 | GR445 | 84.80 | GR462 | 169.00 |
| 0.0250 | 0.6350 | White | 10 | GR446 | 97.90 | GR463 | 191.00 |
| 0.0300 | 0.7620 | Coral | 10 | GR447 | 97.90 | GR464 | 191.00 |
| 0.0400 | 1.0160 | Clear | 3 | GR448 | 43.70 | GR465 | 81.80 |
| 0.0500 | 1.2700 | Clear | 3 | GR449 | 43.70 | GR466 | 86.60 |
| 0.0600 | 1.524 | Clear | 3 | GR450 | 58.80 | GR467 | 99.90 |

PLASTIC SHIM STOCK COLOUR-CODED ASSORTMENTS

Each assortment contains 1 each of the following: 0.0005", 0.001", 0.0015", 0.002", 0.003", 0.004", 0.005", 0.0075", 0.010", 0.015", 0.020", 0.025", 0.030"

| Model No. | Description | Price/Each |
|-----------|---------------------|------------|
| GR468 | 5" x 20" 14 sheets | 82.10 |
| GR469 | 10" x 20" 14 sheets | 164.00 |

FEELER GAGE STOCKS

- Precision Brand feeler gage is made from 1/2" wide spring steel stock, close grain C1095 high-carbon steel
- Hardened and tempered to RC 48-62
- Thickness clearly etched
- Material is ground and polished to precision tolerances
- 12 pieces per box



FEELER GAGE STOCK FLAT LENGTHS 1/2" X 12"

| Model No. | Thickness Inch | cm | Price /Each | Model No. | Thickness Inch | cm | Price /Each |
|-----------|-------------------|--------|----------------|-----------|-------------------|--------|----------------|
| GR470 | 0.0010 | 0.0250 | 102.00 | GR487 | 0.0160 | 0.4060 | 39.00 |
| GR471 | 0.0015 | 0.0380 | 54.30 | GR488 | 0.0170 | 0.4320 | 39.00 |
| GR472 | 0.0020 | 0.0510 | 54.30 | GR489 | 0.0180 | 0.4570 | 39.00 |
| GR473 | 0.0025 | 0.0640 | 54.30 | GR490 | 0.0190 | 0.4830 | 39.00 |
| GR474 | 0.0030 | 0.0760 | 54.30 | GR491 | 0.0200 | 0.5080 | 39.00 |
| GR475 | 0.0040 | 0.1020 | 44.20 | GR492 | 0.0210 | 0.5330 | 39.00 |
| GR476 | 0.0050 | 0.1270 | 44.20 | GR493 | 0.0220 | 0.5590 | 39.00 |
| GR477 | 0.0060 | 0.1520 | 44.20 | GR494 | 0.0230 | 0.5840 | 39.00 |
| GR478 | 0.0070 | 0.1780 | 39.00 | GR495 | 0.0240 | 0.6100 | 39.00 |
| GR479 | 0.0080 | 0.2030 | 39.00 | GR496 | 0.0250 | 0.6350 | 39.00 |
| GR480 | 0.0090 | 0.2290 | 39.00 | GR497 | 0.0280 | 0.7110 | 39.00 |
| GR481 | 0.0100 | 0.2540 | 39.00 | GR498 | 0.0300 | 0.7620 | 39.00 |
| GR482 | 0.0110 | 0.2790 | 39.00 | GR499 | 0.0310 | 0.7870 | 40.60 |
| GR483 | 0.0120 | 0.3050 | 39.00 | GR500 | 0.0320 | 0.8130 | 40.60 |
| GR484 | 0.0130 | 0.3300 | 39.00 | GR501 | 0.0340 | 0.8640 | 40.60 |
| GR485 | 0.0140 | 0.3560 | 39.00 | GR502 | 0.4000 | 1.0160 | 40.70 |
| GR486 | 0.0150 | 0.3810 | 39.00 | | | | |

STEEL FEELER GAGE ASSORTMENT

The "Big Poc-Kit" Assortment
Contains 20 Blades - 1/2" X 12" including case

Model No. GR503
Price/Each \$119.00

KEY STOCKS



ZINC PLATED

| Model No. | Size" | Length" | Price /Each |
|-----------|--------|---------|-------------|
| GR183 | 3/32 | 12 | 7.04 |
| GR184 | 1/8 | 12 | 2.07 |
| GR185 | 5/32 | 12 | 2.62 |
| GR186 | 3/16 | 12 | 2.14 |
| GR187 | 7/32 | 12 | 3.27 |
| GR188 | 1/4 | 12 | 2.66 |
| GR189 | 9/32 | 12 | 4.18 |
| GR190 | 5/16 | 12 | 3.58 |
| GR191 | 3/8 | 12 | 4.36 |
| GR192 | 7/16 | 12 | 5.69 |
| GR193 | 1/2 | 12 | 7.25 |
| GR194 | 9/16 | 12 | 13.70 |
| GR195 | 5/8 | 12 | 11.50 |
| GR196 | 11/16 | 12 | 19.60 |
| GR197 | 3/4 | 12 | 15.10 |
| GR198 | 13/16 | 12 | 28.50 |
| GR199 | 7/8 | 12 | 20.10 |
| GR200 | 1 | 12 | 24.50 |
| GR201 | 1-1/8 | 12 | 44.50 |
| GR202 | 1-3/16 | 12 | 69.70 |
| GR203 | 1-1/4 | 12 | 57.50 |
| GR204 | 1-3/8 | 12 | 64.70 |
| GR205 | 1-1/2 | 12 | 77.20 |
| GR206 | 1-3/4 | 12 | 107.00 |
| GR207 | 2 | 12 | 152.00 |

- Steel keystock is used to provide driving torque between shafts and pulleys, gears, sprockets, etc.
- Material is high-quality, cold-drawn, low carbon C1018 steel
- Most tolerances on material are oversized to assure tight fit in keyways for positive, zero backlash power transmission
- Meets ASTM standard A-108

ZINC-PLATED KEYSTOCK TOLERANCES

| Size" | Square" |
|---------------|---------------|
| 3/32 - 5/8 | +0.003/-0 |
| 11/16 | +0.001/-0.004 |
| 3/4 | +0.003/-0 |
| 13/16 - 1-1/2 | +0.004/-0 |
| 1-3/4 - 2 | +0.005/-0 |

STAINLESS STEEL

| Model No. | Fraction Size" | Metric Size mm | Length" | Price /Each |
|-----------|----------------|----------------|---------|-------------|
| GR251 | 1/8 | 3.18 | 12 | 6.17 |
| GR252 | 3/16 | 4.76 | 12 | 6.19 |
| GR253 | 1/4 | 6.35 | 12 | 8.88 |
| GR254 | 5/16 | 7.94 | 12 | 18.20 |
| GR255 | 3/8 | 9.53 | 12 | 20.20 |
| GR256 | 7/16 | 11.11 | 12 | 28.20 |
| GR257 | 1/2 | 12.70 | 12 | 37.00 |
| GR258 | 5/8 | 15.88 | 12 | 59.40 |
| GR259 | 3/4 | 19.05 | 12 | 73.50 |
| GR260 | 7/8 | 22.23 | 12 | 106.00 |
| GR261 | 1 | 25.40 | 12 | 135.00 |

STAINLESS STEEL KEYSTOCK ASSORTMENT

| Model No. | Sizes" | Length" | Qty Each | Price /Each |
|-----------|--------|---------|----------|-------------|
| GR262 | 3/16 | 12 | 4 | 453.00 |
| | 1/4 | 12 | 4 | |
| | 5/16 | 12 | 4 | |
| | 3/8 | 12 | 4 | |
| | 7/16 | 12 | 4 | |
| | 1/2 | 12 | 4 | |

ZINC-PLATED KEYSTOCK ASSORTMENT

| Model No. | Sizes" | Length" | Qty Each | Price/Each |
|-----------|--------|---------|----------|------------|
| GR208 | 3/16 | 12 | 6 | 130.00 |
| | 5/16 | 12 | 6 | |
| | 7/16 | 12 | 4 | |
| | 1/2 | 12 | 4 | |

ELECTRONIC DIGITAL MICROMETERS

- Large LCD display provides easy-to-read numbers
- Carbide tipped measurement surfaces
- Resolution to 5 decimal places
- Linear accuracy: +/- .0001" (.003 mm)
- Inch/millimetre conversion
- Includes calibration wrench
- Zero at any position
- Lock screw to hold mechanism in position
- Automatic OFF button
- Includes: Thimble ratchet, two 1.5 V batteries, type LR44, wooden storage case with foam insert



aurora tools®

| Model No. | Measurement Range | Resolution | Price /Each |
|-----------|-------------------|--------------------|-------------|
| IA388 | 0-1" (0-25mm) | 0.00005" (0.001mm) | 129.00 |

STAINLESS STEEL ELECTRONIC DIGITAL CALIPERS

- Large LCD display provides easy-to-read numbers
- Precision adjustments for accurate measurements
- Hardened stainless steel body and zinc alloy head
- Lock screw to hold slide in position
- Linear accuracy: +/- .001" (.03 mm)
- Inch/millimeter conversion
- Zero at any position
- ON/OFF button
- Includes: Two 1.5 V batteries, type LR44 and deluxe storage case with foam inserts

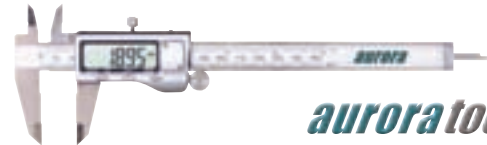

aurora tools®

| Model No. | Size | Measurement Range | Approximate Jaw Depth | Price/Each |
|-----------|------|-------------------|---|------------|
| TGZ370 | 6 | 0-6" (152 mm) | 1 1/2" (40 mm) outside, 5/8" (21 mm) inside | 67.30 |
| TJZ861 | 8 | 0-8" (200 mm) | 1 13/16" (46 mm) outside, 1" (26 mm) inside | 81.55 |
| THZ769 | 12 | 0-12" (300 mm) | 2 3/8" (60 mm) outside, 1" (26 mm) inside | 149.00 |

MICROMETER

- Carbide measuring faces
- Clear graduations on satin chrome finish
- Hammertone baked enamel finish
- Ratchet stop
- Supplied in fitted plastic case



Mitutoyo

| Model No. | Mfg. No. | Measuring Range | Resolution | Accuracy +/- | Price /Each |
|-----------|----------|--------------------|----------------------|----------------------|-------------|
| HA216 | 103-260 | 0"-1" (0 mm-25 mm) | 0.0001" (0.00254 mm) | 0.0001" (0.00254 mm) | 129.00 |

6" ELECTRONIC DIGITAL CALIPERS

- Large LCD display provides easy-to-read numbers
- Precision adjustments for accurate measurements
- ABS plastic head and stainless steel body
- Lock screw to hold slide in position
- Approximate jaw depth: 1 9/16" (40 mm) outside, 13/16" (21 mm) inside
- Inch/millimeter conversion
- Zero at any position
- Automatic shut OFF
- Includes two 3 V batteries, type CR2032 and a deluxe storage case with foam insert

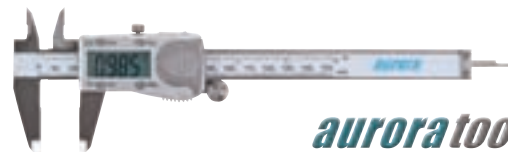

aurora tools®

| Model No. | Measurement Range | Resolution | Price /Each |
|-----------|-------------------|-----------------|-------------|
| TLV181 | 0-6" (0-152 mm) | 0.001" (0.03mm) | 49.95 |

DIAL POCKET GAUGES

- Ideal for verifying materials up to 3/8" (9 mm) thick
- Case is chrome plated with an unbreakable crystal
- Flat contacts
- Protective case included



Starrett®

| Model No. | EDP No. | Dial Graduation" | Dial Reading | Range" | Accuracy +/- | Price /Each |
|-----------|---------|------------------|--------------|--------|--------------------|-------------|
| HW235 | 53114 | 0.001 | 0-100 | 0.375 | 0.001" (0.0254 mm) | 404.00 |

ABS DIGIMATIC CALIPER

- Digital readout LCD shows inch or metric units for versatility when measuring
- Advanced onsite sensor (AOS) electromagnetic inductive sensor for resistance to dirt, oil, and water
- Measures inside, outside, depth, and step values for versatility
- Includes protective case and SR44 silver oxide battery



Mitutoyo

| Model No. | Mfg. No. | Measuring Range | Resolution | Accuracy +/- | Price /Each |
|-----------|------------|---------------------|-------------------|--------------------|-------------|
| HM704 | 500-196-30 | 0"-6" (0 mm-152 mm) | 0.0005" (0.01 mm) | 0.001" (0.0254 mm) | 191.00 |

MEASURES, RULES, SQUARES & LEVELS



700 SERIES MAGNETIC END HOOK MEASURING TAPES

- Magnetic end hook is a time-saver for framers, HVAC installers and more
- Use for one-man measurements of steel framing and drop ceiling grids
- Powerful dual magnets can also serve as a pick-up tool
- Non-slip co-molded rubber grip
- Durable clear coat blade protection for longer blade life
- Steel reinforced end hook for longer service life
- Tough ABS case to stand up to the toughest work site



TLZ076

Lufkin®

| Model No. | Mfg. No. | Blade Width" | Length | Graduations | Stud Markings" | Price /Each |
|-----------|----------|--------------|--------|-------------|----------------|-------------|
| TLZ169 | L725MAG | 1 | 25' | in/ft. | 16/19.2 | 16.30 |
| TLZ076 | L748MAG | 1 | 26/8 m | in/cm | 16/19.2 | 16.30 |

800 SERIES EXTRA-WIDE POWER RETURN MEASURING TAPES

- New blade design achieves 10' stand-out, make longer measurements
- Soft touch lock button for better feel and control
- Rubber cushion absorbs impact and improved grip
- Clear coat blade protection - more durable markings
- 4-rivet end hook - increased strength for long blade life
- Non-slip slide lock for positive blade locking
- Easy on/off belt clip for fast attachment to belt
- Orange case designed to fit your hand



Lufkin®

| Model No. | Mfg. No. | Blade Width" | Length' | Graduations | Price /Each |
|-----------|----------|--------------|---------|-------------|-------------|
| IA627 | XL8525 | 1 3/16 | 25 | in/ft. | 21.60 |

AUTOLOCK MEASURING TAPES

- High visibility with rubber comfort grip
- Automatic blade lock
- Recessed lock release
- TLZ075 comes with magnetic end hook



TJZ389

Lufkin®

| Model No. | Mfg. No. | Blade Width" | Length | Graduations | Stud Markings" | Price /Each |
|-----------|----------|--------------|--------|-------------|----------------|-------------|
| TJZ389 | AL725 | 1 | 25' | in/ft. | 16/19.2 | 13.90 |
| TJZ388 | AL748CME | 1 | 26/8 m | in/cm | 16/19.2 | 13.90 |
| TLZ075 | AL725MAG | 1 | 25' | in/ft. | 16/19.2 | 18.10 |

SERIES 2000 MEASURING TAPES

- Case designed to fit perfectly in the hand
- Lightweight, high strength chrome finished case
- Fits easily into most tape holsters
- Bright yellow blade has clear easy-to-read numerals
- Toggle lock positioned for convenient operation, holds blade securely
- Cushioned blade return
- Removable belt clip



TLV593

Lufkin®

| Model No. | Mfg. No. | Blade Width" | Length | Graduations | Stud Markings" | Price /Each |
|-----------|----------|--------------|---------|-------------|----------------|-------------|
| TLV588 | P2212 | 1/2 | 12' | in/ft. | 16" | 16.60 |
| TLV593 | P2312 | 3/4 | 12' | in/ft. | 16" | 18.60 |
| TLV602 | P2316 | 3/4 | 16' | in/ft. | 16" | 22.30 |
| TLV607 | P2125 | 1 | 25' | in/ft. | 16"/19.2" | 25.60 |
| TLV618 | P2133 | 1 | 33' | in/ft. | 16"/19.2" | 31.10 |
| TLV585 | P2024CME | 1/2 | 12/4 m | in/cm | - | 16.60 |
| TLV591 | P2034CME | 3/4 | 13/4 m | in/cm | - | 18.60 |
| TLV600 | P2035CME | 3/4 | 16/5 m | in/cm | - | 22.30 |
| TLV608 | P2048CME | 1 | 26/8 m | in/cm | - | 26.10 |
| TLV617 | P2410CME | 1 | 33/10 m | in/cm | 19.2" | 31.10 |
| TLV601 | P2335ME | 3/4 | 16/5 m | in/cm | 16"/40 cm | 22.60 |
| TLV599 | P2035CM | 3/4 | 5 m | mm/m | - | 22.30 |

HI-VIZ® ORANGE MEASURING TAPES

- Hi-Viz® orange case - easy to find on the job
- Rubber cushion case exterior protects tape from impact and improves grip
- Fits easily into most tape holsters
- Bright yellow blade has clear easy-to-read numerals
- Toggle lock is positioned for convenient operation
- Holds the blade securely in any position
- Cushioned blade return
- Removable belt clip



TLV589

Lufkin®

| Model No. | Mfg. No. | Blade Width" | Length | Graduations | Stud Markings" | Price /Each |
|-----------|------------|--------------|----------|-------------|----------------|-------------|
| TLV589 | PHV1012 | 1/2 | 12' | in/ft. | 16 | 11.70 |
| TLV596 | PHV1312 | 3/4 | 12' | in/ft. | 16 | 14.20 |
| TLV605 | PHV1316 | 3/4 | 16' | in/ft. | 16 | 16.30 |
| TLV612 | PHV1425 | 1 | 25' | in/ft. | 16/19.2 | 21.10 |
| TLV620 | PHV1433 | 1 | 33' | in/ft. | 16/19.2 | 24.90 |
| TLV590 | PHV1024CME | 1/2 | 12/3.6 m | in/cm | - | 12.10 |
| TLV594 | PHV1034CME | 3/4 | 12/3.6 m | in/cm | - | 14.20 |
| TLV604 | PHV1035CME | 3/4 | 16/5 m | in/cm | - | 16.60 |
| TLV610 | PHV1048CME | 1 | 26/8 m | in/cm | 19.2 | 21.50 |
| TLV619 | PHV1410CME | 1 | 33/10 m | in/cm | 19.2 | 25.70 |

LUFKIN CONTROL SERIES

- New design gives users maximum control when extending and retracting the tape blade
- The Drag Strip™ access opening on the bottom of the tape allows users to regulate blade feed and return with their fingertip for greater control
- 10' stand-out capacity and extra-wide end hook make this tape perfect for the toughest jobs
- Integrated D-ring for tether strap or easy hanging storage



TLV746

Lufkin®

| Model No. | Mfg. No. | Blade Width" | Length | Graduations | Stud Markings" | Price /Each |
|-----------|-----------|--------------|-----------|-------------|----------------|-------------|
| TLV745 | CS8516 | 3/4 | 16' | in/ft. | 16/19.2 | 17.50 |
| TLV746 | CS8525 | 1 3/16 | 25' | in/ft. | 16/19.2 | 25.40 |
| TLV747 | CS8525CME | 1 3/16 | 26' (8 m) | in/cm | 16/19.2 | 25.10 |

MEASURES, RULES, SQUARES & LEVELS

KTX SERIES MEASURING TAPES

- Red ABS plastic and ergonomic design provides durability and comfort
- Positive sliding lock holds tape securely while transferring measurement to work surfaces
- Blade colour: Yellow
- Protective nylon coating provides 2X blade abrasion resistance, protecting numbers and graduations
- End type: Self adjusting end hook
- Includes a steel belt clip



TLV532

Starrett®

| Model No. | Mfg. No. | Blade Width" | Length | Graduation Style | Graduations | Price /Each |
|-----------|--------------|--------------|--------|------------------|-----------------------|-------------|
| TLV538 | KTX34-16-N | 3/4 | 16' | English | 1/16" | 11.80 |
| TLV537 | KTX34-16ME-N | 3/4 | 16' | English/Metric | 1/16" and Millimeters | 11.80 |
| TLV539 | KTX34-5M-N | 3/4 | 5 m | Metric | Millimeters | 11.80 |
| TLV530 | KTX12-12-N | 1/2 | 12' | English | 1/16" | 8.55 |
| TLV529 | KTX12-12ME-N | 1/2 | 12' | English/Metric | 1/16" and Millimeters | 8.48 |
| TLV531 | KTX12-3.5M-N | 1/2 | 3.5 m | Metric | Millimeters | 8.55 |
| TLV532 | KTX1-25-N | 1 | 25' | English | 1/16" | 20.40 |
| TLV533 | KTX1-26ME-N | 1 | 26' | English/Metric | 1/16" and Millimeters | 21.40 |
| TLV534 | KTX1-30-N | 1 | 30' | English | 1/16" | 24.20 |
| TLV535 | KTX1-35-N | 1 | 35' | English | 1/16" | 28.10 |
| TLV536 | KTX1-8M-N | 1 | 8 m | Metric | Millimeters | 21.50 |

MEASURING TAPES

- Heavy-duty tape line
- Sure locking break
- Easy-to-read blade
- Two rivets holding the tip for extra security
- Composite covering for extra comfort



TJZ115

aurora tools®

| Model No. | Blade Width" | Length' | Graduations | Price /Each |
|-----------|--------------|---------|-------------|-------------|
| TJZ115 | 5/8 | 12 | in/ft. | 4.85 |
| TJZ116 | 5/8 | 12 | in/cm | 4.85 |
| TJZ117 | 3/4 | 16 | in/ft. | 5.95 |
| TJZ118 | 3/4 | 16 | in/cm | 5.95 |
| TJZ801 | 1 | 25 | in/ft. | 10.15 |
| TJZ802 | 1 | 25 | in/cm | 10.15 |
| TJZ803 | 1 | 30 | in/ft. | 13.20 |
| TJZ804 | 1 1/4 | 25 | in/ft. | 15.95 |

KTXP SERIES MEASURING TAPES

- Silver-grey high impact resistant PC- ABS plastic for superior case life
- Positive sliding lock holds tape securely while transferring measurement to work surface
- Blade colour: Yellow
- Protective nylon coating provides 2X blade abrasion resistance, protecting numbers and graduations
- End type: Self adjusting end hook
- Includes a black anodized steel belt clip



TLV542

Starrett®

| Model No. | Mfg. No. | Blade Width" | Length | Graduation Style | Graduations | Price /Each |
|-----------|----------------|--------------|----------|------------------|-----------------------|-------------|
| TLV542 | KTXP106-25-N | 1 | 25' | English | 1/16" | 29.80 |
| TLV543 | KTXP106-26ME-N | 1 | 26 7/8 m | English/Metric | 1/16" and Millimeters | 30.90 |
| TLV545 | KTXP106-35-N | 1 | 35' | English | 1/16" | 40.40 |
| TLV541 | KTXP106-16-N | 1 | 16' | English | 1/16" | 21.70 |
| TLV540 | KTXP106-16ME-N | 1 | 16 7/5 m | English/Metric | 1/16" and Millimeters | 21.50 |
| TLV544 | KTXP106-30-N | 1 | 30' | English | 1/16" | 35.60 |

KTS SERIES MEASURING TAPES

- Yellow ABS plastic provides a highly visible, durable case
- Positive sliding lock holds tape securely while transferring measurement to work surfaces
- Blade colour: Yellow
- Protective coating: Clear coat polyurethane
- End type: Self adjusting end hook
- Includes a steel belt clip



TLV515

Starrett®

| Model No. | Mfg. No. | Blade Width" | Length' | Graduation Style | Graduations | Price /Each |
|-----------|-------------|--------------|---------|------------------|-----------------------|-------------|
| TLV514 | KTS1-25-N | 1 | 25 | English | 1/16" | 11.40 |
| TLV515 | KTS1-26ME-N | 1 | 26 | English/Metric | 1/16" and Millimeters | 12.10 |
| TLV516 | KTS1-33-N | 1 | 33 | English | 1/16" | 15.80 |

See page 1482 for
Laser Distance Meters



LONG MEASURING TAPES

- High-visibility, high-impact case
- Easy-to-read blade
- English marking on one side, metric on the other
- Easy-wind blade return



| Model No. | Mfg. No. | Blade Width" | Length | Graduations | Stud Markings" | Price /Each |
|-----------|----------|--------------|-----------|---------------|----------------|-------------|
| TY324 | HV15CME | 3/8 | 50'/15 m | in/ft. - m/cm | 16 | 24.50 |
| TY325 | HV30CME | 3/8 | 100'/30 m | in/ft. - m/cm | 16 | 36.10 |

PRO SERIES NY-CLAD® STEEL MEASURING TAPES

- High-visibility, high-impact orange case
- Easy-to-read blade
- Steel tape (nominal thickness 0.022") is nylon clad for long life
- Fast-rewind blade return



| Model No. | Mfg. No. | Blade Width" | Length' | Graduations | Price /Each |
|-----------|----------|--------------|---------|---------------------|-------------|
| TJ789 | PS1806N | 1/2 | 100 | in/ft. (1/8) | 82.30 |
| TJ790 | PS1806DN | 1/2 | 100 | in/ft. (1/10-1/100) | 83.10 |
| TJ791 | PS1808N | 1/2 | 200 | in/ft. (1/8) | 129.00 |
| TJ792 | PS1808DN | 1/2 | 200 | in/ft. (1/10-1/100) | 129.00 |

SMALL MEASURING WHEELS

- Small wheel ideal for flat surfaces
- Dial indicator measures up to 999' 11" without resetting
- Telescoping handle reduces to 17" for easy storage
- Measure as fast as you can walk
- Fits in most briefcases



| Model No. | Mfg. No. | Measures | Graduations | Price /Each |
|-----------|----------|----------|-------------|-------------|
| TJ797 | MW18TP | Imperial | in/ft. | 59.90 |
| TJ798 | MW18M | Metric | dm/m | 59.90 |

LARGE MEASURING WHEELS

- Large wheel ideal for rough terrain or flat surfaces
- Dial indicator measures up to 9999' 11" without resetting
- Retractable handle adjusts for user comfort
- Measure as fast as you can walk
- Rubber wheel with tough plastic hub



| Model No. | Mfg. No. | Measures | Graduations | Price /Each |
|-----------|----------|----------|-------------|-------------|
| TJ795 | MW38TP | Imperial | in/ft. | 124.00 |
| TJ796 | MW38M | Metric | dm/m | 124.00 |

FIBREGLASS MEASURING TAPES

- High-visibility, high-impact case
- Easy-to-read blade
- English marking on one side, metric on the other
- Fast-rewind blade return



| Model No. | Mfg. No. | Blade Width" | Length | Graduations | Price /Each |
|-----------|----------|--------------|------------|---------------|-------------|
| TY326 | FM015CME | 1/2 | 50'/15 m | in/ft. - m/cm | 22.60 |
| TY327 | FM030CME | 1/2 | 100'/30 m | in/ft. - m/cm | 28.30 |
| TY328 | FM050CME | 1/2 | 164'/50 m | in/ft. - m/cm | 53.90 |
| TY329 | FM100CME | 1/2 | 330'/100 m | in/ft. - m/cm | 76.30 |

EXTRA-WIDE FIBREGLASS LONG MEASURING TAPES

- Ring end hook snaps onto stake for 1-person measurements
- Standard folding end hook for general measuring needs
- 3-to-1 rewind for fast blade retraction
- 3/4" 2-sided blade is more durable; large numbers are easy to read
- Fibreglass strands and double-PVC coating for durability and strength
- Cushion grips on handle and frame arms for comfort
- Includes three interchangeable end attachments



| Model No. | Mfg. No. | Blade Width" | Length | Graduations | Price /Each |
|-----------|------------|--------------|------------|----------------------|-------------|
| TLV311 | PSFE100 | 3/4 | 100' | in/ft. - decimal ft. | 84.90 |
| TLV312 | PSFE200 | 3/4 | 200' | in/ft. - decimal ft. | 135.00 |
| TLV313 | PSFE300 | 3/4 | 300' | in/ft. - decimal ft. | 159.00 |
| TLV314 | PSFM030CME | 3/4 | 30 m/100' | in/ft. - mm/cm/m | 99.90 |
| TLV315 | PSFM060CME | 3/4 | 60 m/200' | in/ft. - mm/cm/m | 131.00 |
| TLV316 | PSFM100CME | 3/4 | 100 m/328' | in/ft. - mm/cm/m | 162.00 |

DISTANCE MEASURING WHEELS

- Ideal for road distance measuring applications
- Fitted with a 1 m circumference wheel
- Two measuring modes: Trip and Total
- Accuracy: ± 1%
- Adds forward, subtracts in reverse
- Metric and imperial measurement
- Measure in meters, yards or feet and inches at the push of a button
- Large LCD display is crystal clear in direct sunlight
- Backlight for low light conditions
- Waterproof for all weather conditions
- Push button reset
- Electronic brake
- Telescopic handle
- Mud scraper
- Minimum 3-year battery life



| Model No. | Mfg. No. | Description | Price/Each |
|-----------|----------|--------------------------|------------|
| HC438 | 5505E | Distance Measuring Wheel | 139.00 |

MEASURES, RULES, SQUARES & LEVELS

ATLAS® CHROME CLAD®/NUBIAN® DOUBLE DUTY OIL-GAUGING TAPE LINES

- Black markings bonded to steel, recessed beneath multiple layers of nickel and chrome electroplating
- Chrome Clad® and Nubian® (black) for dark (heavy) and light (clear) oils
- All tapes read right to left
- Heavy-duty frame designed for years of rugged use
- All frames include a grounding strap
- Plumb bob must be ordered separately

Lufkin®



| Model No. | Mfg. No. | Blade Width | Blade Length | Blade Graduations | Blade Reading | Price /Each |
|---------------------------|--------------|-------------|--------------|-------------------|---------------|-------------|
| FOR INAGE GAUGING | | | | | | |
| TBG548 | CN1290SF590 | 1/2" | 25' | in/ft. | 1/8" | 244.00 |
| TBG549 | CN1290SME | 13 mm | 26/8 m | in/ft. - m | 1/8"/1 mm | 257.00 |
| QZ024 | CN1293SF590 | 1/2" | 50' | in/ft. | 1/8" | 284.00 |
| TBG553 | CN1293SMEF59 | 13 mm | 50/15 m | in/ft. - m | 1/8"/1 mm | 329.00 |
| TBG557 | CN1295SF590 | 1/2" | 75' | in/ft. | 1/8" | 376.00 |
| TBG559 | CN1295SME590 | 13 mm | 75/23 m | in/ft. - m | 1/8"/1 mm | 423.00 |
| TBG560 | CN1296SF590 | 1/2" | 100' | in/ft. | 1/8" | 468.00 |
| TBG561 | CN1296SMEF59 | 13 mm | 100/30 m | in/ft. - m | 1/8"/1 mm | 551.00 |
| FOR OUTAGE GAUGING | | | | | | |
| TBG552 | CN1293SF5871 | 1/2" | 50' | in/ft. | 1/8" | 284.00 |
| TBG554 | CN1294SF5871 | 1/2" | 66' | in/ft. | 1/8" | 339.00 |
| TBG558 | CN1295SME | 13 mm | 75/23 m | in/ft. - m | 1/8"/1 mm | 423.00 |

OIL GAUGING PLUMB BOBS

- Inage bobs are cylindrical shaped, 1" x 6 3/4" L
- Outage bobs are square shaped, 7/8" x 6" L
- Outage bobs Zero falls inside top of hook eye

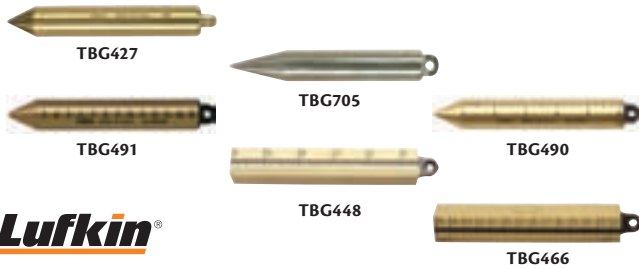

Lufkin®

| Model No. | Mfg. No. | Material | Graduations | Gauging Type | Weight oz. | Price /Each |
|-----------|----------|-----------------|-------------|--------------|------------|-------------|
| TBG427 | TT590 | Brass | None | Inage | 20 | 71.90 |
| TBG705 | S590N | Stainless Steel | None | Inage | 20 | 148.00 |
| TBG490 | 590GN | Brass | in. | Inage | 20 | 93.50 |
| TBG491 | 590GMN | Brass | mm/cm | Inage | 20 | 93.50 |
| TBG492 | 590GMEN | Brass | mm/in. | Inage | 20 | 93.50 |
| TBG448 | 58712N | Brass | in. | Outage | 20 | 119.00 |
| TBG466 | T150MM | Brass | mm/cm | Outage | 20 | 129.00 |

EXACT® CHALK LINES 100' (30 M)

- Produced with high impact-resistant case with overmold
- Holds 4 oz. of chalk
- Features 100' press to release line
- Manufactured with 1:6 rewind ratio
- Includes stainless steel hook

TLV646



Starrett®

| Model No. | Mfg. No. | Description | Price /Each |
|-----------|----------|--------------------------------------|-------------|
| TLV646 | 30731 | 100'/30 m Line | 16.90 |
| TLV647 | 00152 | 100'/30 m Line with 4-oz. Blue Chalk | 18.60 |
| TLV648 | 00153 | 100'/30 m Line with 4-oz. Red Chalk | 18.70 |

CHALK REFILLS

- Lays down a hard, clean line that will not blow away
- Easy-to-use plastic bottle with no-spill cap
- For use in all chalk line reels
- Available in red, white and blue



Starrett®

| Model No. | Mfg. No. | Unit Weight | Colour | Price /Each |
|-----------|----------|---------------|--------|-------------|
| TBD711 | 63146 | 8 oz. (227 g) | Blue | 2.84 |
| TBD712 | 63147 | 8 oz. (227 g) | Red | 2.86 |
| TBD713 | 63148 | 8 oz. (227 g) | White | 2.88 |

STRAIT-LINE MACH 6 CHALK REELS

- Six times faster than traditional chalk reels
- 6:1 gear ratio
- Aluminum housing with metal components
- Metal handle
- Wide pronged hook
- 100' nylon/polyester braided line
- Chalk not included



IA629

**IRWIN
STRAIT-LINE®**

| Model No. | Mfg. No. | Description | Price /Each |
|-----------|-----------|-----------------------|-------------|
| IA629 | 2031314DS | 100' Chalk Reel | 23.80 |
| TLZ337 | 2031333 | Replacement Line Only | 3.99 |

MEASURE STIX™ STEEL MEASURING TAPE WITH ADHESIVE BACKING

- Sticks to almost any work surface
- High quality precision steel tape
- Permanent adhesive back
- Cut to size with scissors



Starrett®



| Model No. | Mfg. No. | Blade Width | Length | Graduations | Stud Markings* | Price /Each |
|---|----------|--------------|------------|-------------|----------------|-------------|
| ENGLISH READING - LEFT-TO-RIGHT | | | | | | |
| TBD719 | 63168 | 1/2" | 4' | in/ft. | 16 | 8.52 |
| TBD721 | 63170 | 1/2" | 12' | in/ft. | 16 | 11.70 |
| TBD720 | 63169 | 3/4" | 6' | in/ft. | 16 | 10.30 |
| ENGLISH READING - RIGHT-TO-LEFT | | | | | | |
| TBE324 | 66634 | 1/2" | 6' | in/ft. | 16 | 7.94 |
| TBD914 | 64919 | 1/2" | 12' | in/ft. | 16 | 11.80 |
| ENGLISH/METRIC READING - LEFT-TO-RIGHT | | | | | | |
| TBD722 | 63171 | 1/2" - 13 mm | 4' - 1.2 m | ft/in - mm | 16 | 8.52 |
| TBD724 | 63173 | 1/2" - 13 mm | 12' - 4 m | ft/in - mm | 16 | 11.70 |
| TBD723 | 63172 | 3/4" - 19 mm | 6' - 2 m | ft/in - mm | 16 | 10.30 |

OFFICE
PRODUCTS

INSTRUMENTS,
SCALES &
ELECTRICAL

SHIPPING &
PACKAGING

TOOLS &
EQUIPMENT

WELDING &
METALWORKING

SAFETY
EQUIPMENT
& SUPPLIES

JANITORIAL &
MAINTENANCE

MATERIAL
HANDLING &
STORAGE

1279

MEASURES, RULES, SQUARES & LEVELS

ALUMINUM RAFTER SQUARES

- Permanent 1/8" stamped graduations include rafter square layout with tables and Essex board measure
- Clear (silver) anodized finish
- Model **TDP649** is black anodized finish with yellow filled graduations

| Model No. | Size" | Material | Grad." | Price /Each |
|---------------|---------|----------|--------|--------------|
| TDP688 | 16 x 24 | Aluminum | 1/8 | 20.62 |
| TDP649 | 16 x 24 | Aluminum | 1/8 | 32.98 |

STEEL RAFTER SQUARES

- Permanent 1/8" stamped graduations include rafter square layout with tables and Essex board measure
- Rust protective coating

| Model No. | Size" | Material | Grad." | Price /Each |
|---------------|---------|----------|--------|--------------|
| TDP718 | 16 x 24 | Steel | 1/8 | 14.11 |

STEEL CARPENTER SQUARES

- Permanent 1/8" stamped graduations
- Rust protective coating
- Model **TDP720** version available in mm

| Model No. | Size | Material | Grad. | Price /Each |
|---------------|-----------------------|----------|-------|--------------|
| TDP727 | 16" x 24" | Steel | 1/8" | 13.73 |
| TDP720 | 16" x 24" | Steel | mm | 14.11 |
| | (40.64 cm x 60.96 cm) | | | |
| TDP750 | 8" x 12" | Steel | 1/8" | 7.59 |

DRYWALL SCORING SQUARES

- Foam-molded high impact plastic head
- Insert-molded, perforated aluminum blade to accept utility knife point for scoring drywall
- Screened increments in 1/16"
- Black thermal bonded graduations

| Model No. | Size" | Grad." | Price /Each |
|---------------|-------|--------|--------------|
| TDP608 | 24 | 1/16 | 52.82 |

ALUMINUM RAFTER ANGLE SQUARES

- Solid aluminum cast body with exclusive CNC computer machined edges
- Permanent molded graduations
- Low-glare, protective powder coat finish

| Model No. | Size" | Price /Each |
|---------------|-------|--------------|
| TDP719 | 7 | 13.27 |

ALUMINUM RAFTER ANGLE SQUARES

- Solid aluminum cast body with exclusive CNC computer machined edges
- Permanent molded graduations
- Low-glare, protective powder coat finish

| Model No. | Size" | Price /Each |
|---------------|-------|--------------|
| TDP659 | 12 | 27.50 |

STRUCTO-CAST® TRY & MITRE SQUARES

- High impact plastic handle with hand grip and insert-molded blade
- Stainless steel blade with permanent stamped graduations
- Metric version - 1/8" and mm graduations

| Model No. | Size" | Grad. | Price /Each |
|--------------|-------|----------|-------------|
| VS810 | 8 | 1/8", mm | 7.75 |

SLIDING T-BEVEL

- Heavy duty adjustable stainless steel blade will not rust or corrode
- Bamboo handle with routed hand grip
- Stainless steel edging on handle
- Durable locking nut holds blade securely in place

| Model No. | Size" | Price /Each |
|---------------|-------|--------------|
| TYN289 | 8 | 11.38 |

STRUCTO-CAST® SLIDING T-BEVELS

- Durable high-impact plastic handle with hand grip
- Stainless steel blade with wing-nut fastener

| Model No. | Size" | Price /Each |
|---------------|-------|-------------|
| TDP764 | 8 | 6.12 |

ALUMINUM ADJUST-A-SQUARE®

- Heavy-duty extruded aluminum blade with clear (silver) anodized finish
- Screened thermal bonded graduations in black
- Precision machined head and blade lock together for perfect 90°
- Head adjusts to any angle
- Folds flat for easy transport

| Model No. | Size" | Grad." | Price /Each |
|---------------|-------|-----------|--------------|
| TDP603 | 48 | 1/8, 1/16 | 53.31 |

ALUMINUM DRYWALL T-SQUARES

- Extruded aluminum blade and head with clear (silver) anodized finish
- Screened thermal bonded 1/8" graduations in black
- Exclusive designed solid four rivet construction permanently "bonds" head to blade

| Model No. | Size" | Grad." | Price /Each |
|---------------|--------|--------|--------------|
| TDP658 | 47 7/8 | 1/8 | 26.61 |

HEAVY-DUTY ALUMINUM DRYWALL T-SQUARES

- Heavy-duty extruded aluminum blade and head with clear (silver) anodized finish
- Screened thermal bonded 1/8" graduations in black
- Exclusive designed solid four rivet construction permanently "bonds" head to blade

| Model No. | Size" | Grad." | Price /Each |
|---------------|--------|--------|--------------|
| TDP626 | 53 7/8 | 1/8 | 46.01 |

JOHNSON

DIGITAL SLIDING T-BEVELS

- 8" stainless steel blade
- Holds and transfers angles between work pieces
- Auto shut-off feature with full LCD display
- 0.3° accuracy
- Range 0° - 360° (Resolution 0.05°)
- 3 V lithium battery (CR2032) included

GENERAL®

| Model No. | Size" | Price /Each |
|---------------|-------|--------------|
| TLV295 | 8 | 48.63 |

MEASURES, RULES, SQUARES & LEVELS

ALUMINUM TORPEDO LEVELS WITH MAGNETIC BASE

- Oversized solid aluminum base
- Oversized 1/2" diameter vials are easy to read
- V-grooved base for surface leveling and tubular work
- Strong magnetic base
- Model **TLV298** allows you to read slope in 1/8" increments

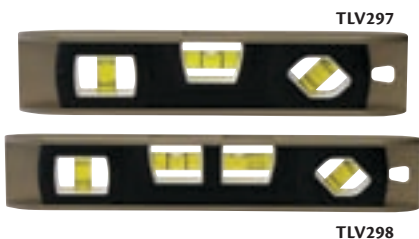

JOHNSON

| Model No. | Mfg. No. | Description | Price /Each |
|-----------|----------|--|-------------|
| TLV297 | 40-2210 | 10", 3 Vials Read Plumb, Level, and 45° | 28.26 |
| TLV298 | 40-2212 | 12", 4 Vials Read Plumb, Level, Multi-Pitch, and 45° | 31.39 |

TRUE BLUE® E70 BOX LEVEL

- True Blue® vials are accurate to within 0.0005" per inch in all working positions
- Heavy-duty 6061 aircraft aluminum chassis
- Shock absorbing endcaps
- Large ergonomic hand grips
- Type: Box
- Material: Aluminum
- No. of Vials: 3
- Non-Magnetic



| Model No. | Mfg. No. | Length' | Price /Each |
|-----------|----------|---------|-------------|
| TY0633 | E70.24 | 2 | 69.90 |
| TY0634 | E70.72 | 6 | 129.00 |
| TY0635 | E70.96 | 8 | 184.00 |

TRUE BLUE® E50 I-BEAM LEVEL

- True Blue® vials are accurate to within 0.0005" per inch in all working positions
- New ergonomic handgrips that provide a comfortable grip
- High visibility plumb vial surrounds make viewing easier in all light conditions
- Durable center vial surround aids visibility and protects the vials
- Type: I-Beam
- Material: Aluminum
- No. of Vials: 3
- Non-Magnetic



| Model No. | Mfg. No. | Length' | Price /Each |
|-----------|----------|---------|-------------|
| TY0630 | E50.24 | 2 | 33.50 |
| TY0631 | E50.48 | 4 | 46.90 |
| TY0632 | E50.72 | 6 | 84.90 |

TRUE BLUE® E80 I-BEAM LEVEL

- True Blue® vials are accurate to within 0.0005" per inch in all working positions
- Strong anodized I-Beam frame
- Shock absorbing endcaps
- Top reading vial window
- Type: I-Beam
- Material: Aluminum
- No. of Vials: 3
- Non-Magnetic



| Model No. | Mfg. No. | Length' | Price /Each |
|-----------|----------|---------|-------------|
| TY0636 | E80.24 | 2 | 34.90 |
| TY0637 | E80.48 | 4 | 69.90 |
| TY0638 | E80.72 | 6 | 91.90 |
| TY0639 | E80.78 | 6.5 | 104.00 |
| TY0640 | E80.96 | 8 | 129.00 |

BIG J® PROFESSIONAL ALUMINUM LEVELS

- Oversized solid aluminum frame is job site tough
- Machined working edges assure maximum accuracy
- Oversized 1/2" diameter vials are easy to read
- Quik-Change® replaceable cover plates and vials for in the field service
- Oversized top-read windows for easy viewing
- SurroundView® vial system for enhanced readability
- Oversized anti-slip/anti-shock end caps protect frame
- Rubberised cushioned hand grips

JOHNSON



| Model No. | Mfg. No. | Description | Price /Each |
|-----------|----------|--------------------|-------------|
| TLZ513 | 40-2224 | Aluminum Level 24" | 39.34 |
| TLZ514 | 40-2248 | Aluminum Level 48" | 57.34 |
| TLZ515 | 40-2272 | Aluminum Level 72" | 97.98 |

TRUE BLUE® E100 DIGITAL LEVEL

- True Blue® vials are accurate to within .0005" per inch in all 10 level and plumb working positions
- Heavy-duty 6061 aircraft aluminum chassis
- Solid block acrylic vials won't break, leak or fog
- Milled edges for accuracy
- Dual molded rubber endcaps for extreme shock resistance
- Gripping surface for assist drawing straight lines
- Laser Level for accurately extending your level capabilities
- Digital Module for accurate reads of slope, pitch and inch/ft in any light
- Type: Box
- Material: Aluminum
- No. of Vials: 3
- Non-Magnetic



| Model No. | Mfg. No. | Length' | Price /Each |
|-----------|----------|---------|-------------|
| TY0628 | E100.24 | 2 | 239.00 |
| TY0629 | E100.48 | 4 | 295.00 |

DIGITAL PRECISION PROTRACTORS

- 6" stainless steel protractor arm with knuckled locking nut
- Absolute and relative measurements
- Large, easy-to-read display
- Accuracy 0.1°
- Range 0° to 180° (Resolution 0.05°)
- 3 V lithium battery (CR2032) included



GENERAL

| Model No. | Mfg. No. | Description | Price /Each |
|-----------|----------|-------------------------|-------------|
| TLV296 | 026008 | Digital Protractor 1702 | 59.27 |

ALUMINUM TOP READ LEVELS

- Durable aluminum frame
- Top reading vial window
- Easy to read cat's-eye green vials

JOHNSON



| Model No. | Mfg. No. | Description | Price /Each |
|-----------|----------|---------------------------|-------------|
| TLZ510 | 40-2050 | 24" level | 20.45 |
| TLZ511 | 40-2054 | 48" level | 30.48 |
| TLZ512 | 40-2060 | 24" level w/magnetic edge | 23.36 |
| VS807 | 40-2064 | 48" level w/magnetic edge | 36.64 |

TRUE BLUE® E80 TORPEDO LEVEL

- True Blue® vials are accurate to within 0.0005" per inch in all working positions
- 4 vials read plumb, level, 45 degree and Vari-Pitch™
- Full length magnetic edge
- Vari-Pitch™ vial reads slope in 1/8" increments
- Length: 12"
- Material: Aluminum
- No. of Vials: 4
- Magnetic



| Model No. | Mfg. No. | Price /Each |
|-----------|----------|-------------|
| TY0641 | E80.9 | 17.90 |

MEASURES, RULES, SQUARES & LEVELS



SELF-LEVELLING FIVE-BEAM LASER POINTERS

- Simultaneously projects five self-levelling beams
- Alarm when unit is beyond accurate range
- Low power indicator
- Locking mechanism protects unit in transport
- Includes: Laser level, multifunction mount, three AA batteries, tinted glasses, magnetic target, strap and carrying case

JOHNSON



TECHNICAL SPECIFICATIONS

| | |
|------------------------------|--|
| Model No. | TGZ560 |
| Mfg. No. | 40-6680 |
| Laser wave length: | 635 nm \pm 10 nm |
| Laser classification: | Class 111A |
| Accuracy: | \pm 1/4" @ 100' (\pm 2 mm @ 10 m) |
| Working range: | Max. 100' (30 m) depending on light conditions |
| Working temperature: | 14°F to 113°F (-10°C to 40°C) |
| Price/Each | \$409.00 |

AUTOMATIC-LEVELLING ROTARY LASER LEVELS

- Automatic-levelling vertical plane and horizontal beam
- Automatic-levelling horizontal plane and plumb beam
- Red beam
- Rotates at two speeds: 120 and 500 RPM
- Integral vertical mount
- Electronically controlled slope feature
- Alarm when unit is beyond accurate range
- Includes: Laser level, NiMH battery pack, 6 V adapter, remote control, beam detector, magnetic target, tinted glasses and carrying case

JOHNSON



TECHNICAL SPECIFICATIONS

| | |
|------------------------------|---|
| Model No. | TGZ551 |
| Mfg. No. | 40-6522 |
| Laser wave length: | 635 nm \pm 10 nm |
| Laser classification: | Class 111A |
| Accuracy: | Horizontal: \pm 1/8" @ 100' (\pm 2 mm @ 10 m) Vertical: \pm 3/16" @ 100' (\pm 5 mm @ 10 m) |
| Working range: | Max. 100' (30 m) depending on light conditions |
| Measuring range: | Max. 984' (300 m) radius with detector |
| Working temperature: | 14°F to 113°F (-10°C to 45°C) |
| Price/Each | \$1589.00 |

JOHNSON™ MULTI POINT CROSS LASER LEVEL

- Automatic self leveling in a few seconds - exact, fast working without manual alignment
- High quality, bright laser diodes for particularly clearly visible lines
- Integrated 1/4" thread - fits all conventional tripods
- Soft grip for a better and more comfortable hold
- Cross, vertical, horizontal and diagonal positioning
- Includes: Laser, wall support, protective case and magnetic wall support

JOHNSON



TECHNICAL SPECIFICATIONS

| | |
|------------------------------|-------------------|
| Model No. | TYO564 |
| Mfg. No. | 40-6658 |
| Laser wave length: | 650 Nm |
| Laser classification: | Class 2 |
| Accuracy: | \pm 0.5 mm/m |
| Leveling time: | <5 s |
| Leveling range: | >4° |
| Max. working range: | 33' (10 m) |
| Working temperature: | 0-40°C |
| Laser line width: | 100 LUX, 2mm/5m |
| Working time: | >15 h |
| Power: | 3 V, 2-AA Battery |
| Price/Each | \$109.00 |

JOHNSON™ 360° ROTARY HEAD LASER LEVEL

- Perfectly projects horizontal 360 degree line accurate alignment of objects in entire room
- Automatic self leveling in a few seconds - exact, fast working without manual alignment
- Precise and very clearly visible laser lines
- Integrated 1/4" thread - fits all conventional tripods
- Soft grip for a better and more comfortable hold
- Cross, vertical, horizontal and diagonal positioning
- Includes: Laser, batteries, case and magnetic wall support

JOHNSON



TECHNICAL SPECIFICATIONS

| | |
|------------------------------|-------------------|
| Model No. | TYO565 |
| Mfg. No. | 40-6642 |
| Laser wave length: | 635 Nm |
| Laser classification: | Class 2 |
| Accuracy: | \pm 0.5 mm/m |
| Leveling time: | 4 s |
| Leveling range: | 4° |
| Max. working range: | 33' (10 m) |
| Working temperature: | 0-40°C |
| Laser line width: | 100LUX, 3mm/5m |
| Power: | 6 V, 4-AA Battery |
| Price/Each | \$269.00 |

MEASURES, RULES, SQUARES & LEVELS

HEAVY-DUTY ELEVATING TRIPODS

- Lightweight durable aluminum construction with elevating platform
- 5/8"-11 mounting screw
- Sharp pointed feet for uneven terrain
- Retractable rubber covers for slick surfaces
- Folds for easy portability
- Adjustable height ranges from 49.825" to 118.25" (126.5 cm to 300 cm)

Model No. TGZ564
Mfg. No. 40-6330
Price/Each \$415.00



ALUMINUM TRIPODS

- Lightweight durable aluminum construction
- 5/8"-11 mounting screw
- Sharp pointed feet for uneven terrain
- Retractable rubber covers for slick surfaces
- Folds for easy portability
- Adjustable height ranges from 41.75" to 67" (106 cm to 170 cm)

Model No. TGZ570
Mfg. No. 40-6340
Price/Each \$124.00



MAGNETIC TORPEDO LASER LEVELS, FLAT BOTTOM

- Built-in, rotating head changes from point to horizontal or vertical lines
- Cross-check vial for more accurate levelling
- Machined gauging edge
- Includes: Laser level, two AAA batteries and carrying case



TECHNICAL SPECIFICATIONS

Model No. TGZ561
Mfg. No. 40-6164
Laser wave length: 650 nm ± 10 nm
Laser classification: Class 111a
Accuracy: ± 1/8" @ 50' (± 1 mm @ 5 m)
Working range: Max. 100' (30 m) depending on light conditions
Working temperature: 14°F to 113°F (-10°C to 40°C)
Price/Each \$82.50

MAGNETIC TORPEDO LASER LEVELS, V-GROOVED BOTTOM

- Built-in, rotating head changes from point to horizontal or vertical lines
- Cross-check vial for more accurate levelling
- V-grooved bottom for use on pipes or conduit
- Includes: Laser level, two AAA batteries, levelling bracket, two mounting straps and carrying case



TECHNICAL SPECIFICATIONS

Model No. TGZ562
Mfg. No. 40-6174
Laser wave length: 650 nm ± 10 nm
Laser classification: Class 111A
Accuracy: ± 1/8" @ 50' (± 1 mm @ 5 m)
Working range: Max. 100' (30 m) depending on light conditions
Working temperature: 14°F to 113°F (-10°C to 40°C)
Price/Each \$119.00

JOHNSON™ TORPEDO LASER SPIRIT LEVEL

- Practical use as a laser level or as a normal spirit level
- The flexible wall holder for all surfaces enables convenient working
- Integrated point laser that precisely transfers heights in the room
- Soft grip for better and more comfortable hold
- Horizontal, vertical or diagonal laser lines, as well as point laser
- High quality, bright laser for particularly clearly visible laser lines and laser points
- Working range up to 3 meters (laser line) and 20 meters (laser point)

JOHNSON



TECHNICAL SPECIFICATIONS

Model No. TYO566
Mfg. No. 40-6188
Laser classification: Class 2
Laser line wave length: 635 Nm
Laser point wave length: 650 Nm
Laser line width: 100 LUX, 3 mm/3 m
Laser point dia. 100 LUX, 15 mm/20 m
Laser line accuracy: 1 mm/m
Laser point accuracy: 0.5 mm/m
Level accuracy: 1 mm/m
Max. working range: 65' (20 m)
Working temperature: 0-40°C
Working time: >15 h
Power: 3 V, 2-AAA Battery
Overall length: 8"
Price/Each \$58.90

3-BEAM LASER POINTERS

- Self-levelling plumb bob is accurate to ±1/4" @ 100'
- One button operation is fast and easy to use
- Overmolded housing helps maintain calibration under job site conditions
- Focused laser beam keeps dot small even over long distances for improved accuracy and visibility
- Locating magnets hold laser plumb bob to metal track for easy positioning
- Cross-hair beam pattern helps user find centre of beam
- Includes: Kit box

DEWALT

TECHNICAL SPECIFICATIONS

Model No. TSW589
Mfg. No. DW083K
Power supply: 4 AA Alkaline
Indoor visibility range: +/- 100'
Laser classification: Class II (<1.5 mW) @ 635 nm
Price/Each \$249.00



SELF-LEVELLING LINE LASERS (HORIZONTAL & VERTICAL)

- Accurate to +/- 1/8" @ 30' for level applications
- Built-in magnetic pivot bracket mounts easily on metal surfaces
- Overmolded housing for job site durability
- One button operation and control panel for ease of use
- Includes: 3 AA batteries for 20+ hours run-time and kit box

DEWALT

TECHNICAL SPECIFICATIONS

Model No. TLZ506
Mfg. No. DW088K
Power supply: 3 AA batteries
Self-Levelling Range: 5'
Indoor visibility range: 100'
Laser classification: Class II
Price/Each \$237.00





BAR CLAMPS FOR WELDING & FABRICATING

SHOP FLOOR CLAMPS

- Swivel pressure pad
- Rail and fixed top jaw are heat treated and tempered
- High quality construction insures long life



| Model No. | Mfg. No. | Pad | Clamping Capacity" | Throat Depth" | Clamping Force (lbs.) | Price /Each |
|-----------|----------|---------------|--------------------|---------------|-----------------------|-------------|
| TKZ890 | 6605-8 | Standard-duty | 8 | 4 | 660 | 64.40 |
| TKZ891 | 6605-12 | Standard-duty | 12 | 4 | 660 | 66.80 |
| TKZ892 | 6605-18 | Standard-duty | 18 | 4 | 660 | 69.80 |
| TN210 | SQ-4 | Standard-duty | 6 | 4 3/4 | 1330 | 63.10 |
| TN211 | SQ-8 | Heavy-duty | 8 | 5 1/2 | 2660 | 94.50 |
| TD320 | SQ-12 | Heavy-duty | 12 | 5 1/2 | 2660 | 135.00 |
| TKZ893 | SQ-16 | Heavy-duty | 16 | 5 1/2 | 2660 | 159.00 |
| TD321 | SQ-20 | Heavy-duty | 20 | 5 1/2 | 2660 | 183.00 |
| TKZ894 | SQ-24 | Heavy-duty | 24 | 5 1/2 | 2660 | 205.00 |

PROFESSIONAL CLAMPS

- Bessey® Morpad™ allows for greater angle of pivot
- Rail and fixed top jaw are heat treated and tempered
- High quality construction insures long life

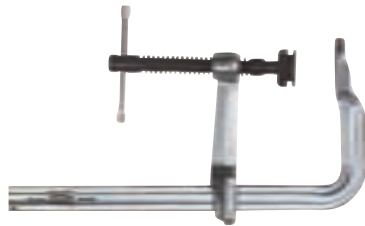

| Model No. | Mfg. No. | Clamping Capacity" | Throat Depth" | Clamping Force (lbs.) | Price /Each |
|-------------------------|----------|--------------------|---------------|-----------------------|-------------|
| HEAVY-DUTY | | | | | |
| TN047 | 48005-12 | 12 | 7 | 4880 | 359.00 |
| THZ886 | 48005-18 | 18 | 7 | 4880 | 405.00 |
| TKZ901 | 48005-24 | 24 | 7 | 4880 | 445.00 |
| THZ887 | 48005-36 | 36 | 7 | 4880 | 492.00 |
| TKZ902 | 48005-48 | 48 | 7 | 4880 | 535.00 |
| TKZ903 | 48005-60 | 60 | 7 | 4880 | 606.00 |
| EXTRA HEAVY-DUTY | | | | | |
| TN177 | 72005-12 | 12 | 8 | 7770 | 869.00 |
| THZ888 | 72005-18 | 18 | 8 | 7770 | 928.00 |
| THZ889 | 72005-36 | 36 | 8 | 7770 | 1066.00 |

REGULAR-DUTY ALL-STEEL BAR CLAMPS WITH ERGONOMIC BESSEY® GRIP



| Model No. | Mfg. No. | Clamping Capacity" | Throat Depth" | Clamping Force (lbs.) | Price /Each |
|-----------|----------|--------------------|---------------|-----------------------|-------------|
| TLY342 | 24005-8 | 8 | 5 1/2 | 2800 | 168.00 |
| TLY343 | 24005-12 | 12 | 5 1/2 | 2800 | 189.00 |
| TLY344 | 24005-16 | 16 | 5 1/2 | 2800 | 217.00 |
| TLY345 | 24005-20 | 20 | 5 1/2 | 2800 | 242.00 |
| TLY346 | 24005-24 | 24 | 5 1/2 | 2800 | 269.00 |
| TLY347 | 24005-36 | 36 | 5 1/2 | 2800 | 339.00 |
| TLY348 | 24005-48 | 48 | 5 1/2 | 2800 | 391.00 |
| TLY349 | 24005-60 | 60 | 5 1/2 | 2800 | 441.00 |

STEP-OVER STEEL CLAMPS

- Rail, fixed jaws and pressure plate heat-formed in one piece from cold drawn profiled and precision steel
- Heat treated, high carbon Acme threaded screw, spatter resistant
- Unique Bessey® Morpad™ tilts to 35° comes standard with TLY352 and TLY353
- Ergonomic Bessey® grip handle on model TLY352



| Model No. | Mfg. No. | Clamping Capacity" | Throat Depth" | Clamping Force (lbs.) | Step-Over" | MorPad | Bessey® /Grip | Price /Each |
|-----------|----------|--------------------|---------------|-----------------------|------------|--------|---------------|-------------|
| TLY351 | J18-8 | 10 | 4 3/4 | 880 | 2 1/4 | - | Yes | 159.00 |
| TLY352 | 2400J-12 | 12 | 5 1/2 | 2660 | 4 | Yes | Yes | 216.00 |
| TLY353 | 4800J-20 | 20 | 7 | 4880 | 6 | Yes | - | 438.00 |

LEVER CLAMPS (LC SERIES)

- Large tilting pressure plate
- Secure ratchet mechanism for rapid vibration-resistant clamping
- Torsion-resistant, fixed bracket and pressure plate produced and tempered in one piece for maximum tensile strength and sturdiness



| Model No. | Mfg. No. | Clamping Capacity" | Throat Depth" | Clamping Force (lbs.) | Price /Each |
|-----------|----------|--------------------|---------------|-----------------------|-------------|
| TLV282 | LC4 | 4 | 2 3/8 | 400 | 91.30 |
| TN207 | LC8 | 8 | 4 | 660 | 105.00 |
| TN205 | LC12 | 12 | 5 1/2 | 1200 | 149.00 |
| TN206 | LC20 | 20 | 4 3/4 | 1200 | 161.00 |
| TLV283 | 1800L12 | 10 | 5 1/2 | 1800 | 303.00 |

MULTI-PURPOSE CLAMPS

- KombiKlamp™ robust Variable Angle Device (VAD) allows for a solid grip on odd shapes - also reverses for spreading
- Ergonomic Bessey® grip offers greater comfort and slides with the T-handle
- Removable screw acts as a slide stop
- Easily converts to a spreading device



Spreading

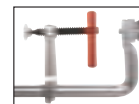

Clamping

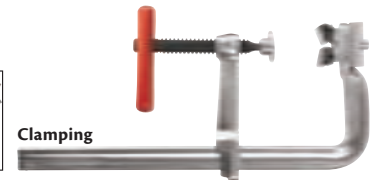

| Model No. | Mfg. No. | Clamping Capacity" | Throat Depth" | Clamping Force (lbs.) | Load Limit (lbs.) | Price /Each |
|-----------|----------|--------------------|---------------|-----------------------|-------------------|-------------|
| TLY350 | SG30VAD | 11 | 4.75 | 2600 | 3000 | 142.00 |

REGULAR-DUTY I BAR CLAMPS NO. 640

- A rapid acting powerful clamp designed and constructed for hard, everyday production work
- Patented, quick action, no slip clutches are 3/4" apart and formed in the web for greater bar strength
- High strength ductile slide cannot slip or bind, easily released
- Steel handle, with comfortable wood crank handle for fast clamping
- Bar dimensions: 7/16" x 1 1/2" x 5/32"
- Screw diameter: 5/8"
- Throat depth is 1 13/16" and clamp face is 1 7/8"



| Model No. | Mfg. No. | Opening Capacity | Load Capacity lbs. | Price /Each |
|-----------|----------|------------------|--------------------|-------------|
| TD798 | 21801 | 2 | 6000 | 58.70 |
| TD800 | 21803 | 3 | 6000 | 73.10 |
| TD801 | 21804 | 4 | 6000 | 81.90 |
| TD802 | 21805 | 5 | 6000 | 90.80 |
| TD803 | 21806 | 6 | 6000 | 104.00 |



VICES, MAGNETS & CLAMPS

WELDERS ANGLE CLAMPS

- Automatic adjustment to work pieces of different thicknesses
- Sturdy jaws and base made from high grade cast iron
- Copper plated spindles resist spatter
- Accurate 90° angle



| Model No. | Mfg. No. | Jaw Height" | Maximum Material Size for Mitre Joints" | Price /Each |
|-----------|----------|-------------|---|-------------|
| TLV361 | WSM9 | 1 3/8 | 3 1/2 | 219.00 |
| TLV362 | WSM12 | 2 2/8 | 4 3/4 | 299.00 |

U STYLE BAR CLAMPS

- Light-duty U style bar clamp offers a unique step-over design
- Small, lightweight and very handy
- Rail is made of quality steel drawn in a single piece for durability and strength
- Sliding arm is made of die cast zinc: light, stable and break resistant
- Comes with non-marking plastic caps on both jaws



| Model No. | Mfg. No. | Clamping Capacity" | Throat Depth" | Clamping Force (lbs.) | Price /Each |
|-----------|----------|--------------------|---------------|-----------------------|-------------|
| TLV358 | LMU2.004 | 4 | 2 | 330 | 9.31 |
| TLV359 | LMU2.006 | 6 | 2 | 330 | 9.68 |
| TLV360 | LMU2.008 | 8 | 2 | 330 | 9.99 |

PIPE CLAMPS, H STYLE

- H shape foot assembly stabilizes clamp in two dimensions giving dual-axis stability
- Extra high base provides industry leading clearance from the work surface
- Cast jaws for durability
- Smooth action spindle
- Pipe not included



| Model No. | Mfg. No. | Pipe Diameter" | Throat Depth" | Price /Each |
|-----------|----------|----------------|---------------|-------------|
| TLV267 | BPC-H34 | 3/4" | 1 3/4 | 24.60 |
| TLV268 | BPC-H12 | 1/2" | 1 1/2 | 21.50 |

CLUTCH STYLE BAR CLAMPS

- Powder coated, malleable cast iron jaws
- 2-piece slip clutch plates for quick adjustment
- Nickel-plated, drawn serrated rail
- Non-marring pads on the top and bottom jaws to protect work surface
- Ergonomically shaped wood handle

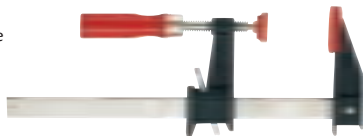

| Model No. | Mfg. No. | Clamping Capacity" | Throat Depth" | Clamping Force (lbs.) | Price /Each |
|-----------|-----------|--------------------|---------------|-----------------------|-------------|
| TLV269 | GSCC2.506 | 6 | 2.5 | 600 | 12.80 |
| TLV270 | GSCC2.512 | 12 | 2.5 | 600 | 14.70 |
| TLV271 | GSCC2.518 | 18 | 2.5 | 600 | 17.20 |
| TLV272 | GSCC2.524 | 24 | 2.5 | 600 | 18.90 |
| TLV273 | GSCC2.530 | 30 | 2.5 | 600 | 20.80 |
| TLV274 | GSCC2.536 | 36 | 2.5 | 600 | 21.90 |
| TLV275 | GSCC3.512 | 12 | 3.5 | 1000 | 21.40 |
| TLV276 | GSCC3.518 | 18 | 3.5 | 1000 | 22.80 |
| TLV277 | GSCC3.524 | 24 | 3.5 | 1000 | 24.50 |
| TLV278 | GSCC5.012 | 12 | 5 | 1200 | 41.20 |
| TLV279 | GSCC5.018 | 18 | 5 | 1200 | 49.90 |
| TLV280 | GSCC5.024 | 24 | 5 | 1200 | 56.70 |

KANT-TWIST® CLAMPS



| Model No. | Mfg. No. | Throat Deep Open" | Throat Deep Closed" | Clamping Capacity" | Clamping Force (lbs.) | Price /Each |
|-----------------------------|----------|-------------------|---------------------|--------------------|-----------------------|-------------|
| ORIGINAL KANT-TWIST® | | | | | | |
| TKZ949 | 1KT | 1/2 | 1/2 | 1 1/16 | 300 | 28.90 |
| TKZ950 | 2KT | 1 1/8 | 1 1/4 | 2 | 700 | 35.00 |
| TKZ952 | 3KT | 1 1/4 | 1 3/4 | 3 | 1500 | 50.00 |
| TKZ953 | 4 1/2KT | 2 1/4 | 2 1/2 | 4 1/2 | 1500 | 53.50 |
| TKZ954 | 6KT | 2 1/8 | 3 3/8 | 6 | 1800 | 81.50 |
| TKZ955 | 6DKT | 4 5/8 | 5 1/2 | 6 | 1800 | 88.90 |

QUICK-GRIP® PIPE CLAMPS

- Innovative clutch system eliminates the need for threaded pipe
- Larger feet offer more stability and clearance between handle and worktop
- Larger, more ergonomic handle offers easier clamping with reduced hand fatigue
- Larger clutch plates allow for easier release and increased durability and dependability

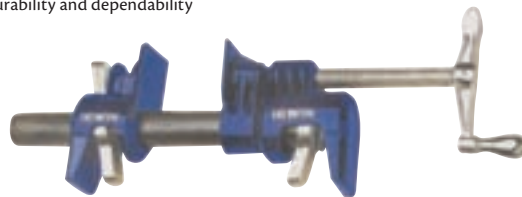

| Model No. | Mfg. No. | Pipe Size | Throat Depth | Price /Each |
|-----------|----------|--------------|----------------|-------------|
| TBR730 | 224134 | 3/4" (19 mm) | 1 7/8" (47 mm) | 26.90 |
| TBR731 | 224212 | 1/2" (12 mm) | 1 1/2" (37 mm) | 22.10 |

QUICK-GRIP® CLUTCH LOCK BAR CLAMPS

- Soft-Grip handle is larger and more ergonomic, allowing high clamping pressure with less effort
- I-beam bar reduces flexing and bowing
- Larger clutch plates allow for easier release, and increase durability and dependability
- 3" throat depth accommodates a variety of projects



| Model No. | Mfg. No. | Clamping Capacity | Throat Depth | Price /Each |
|-----------|----------|-------------------|----------------|-------------|
| TBR488 | 223106 | 6" (15 cm) | 3 1/8" (76 mm) | 21.50 |
| TBR424 | 223112 | 12" (30 cm) | 3 1/8" (76 mm) | 22.70 |
| TBR425 | 223118 | 18" (45 cm) | 3 1/8" (76 mm) | 28.10 |
| TBR426 | 223124 | 24" (60 cm) | 3 1/8" (76 mm) | 30.70 |
| TBR427 | 223136 | 36" (91 cm) | 3 1/8" (76 mm) | 36.40 |

QUICK-GRIP® PASSIVE LOCK BAR CLAMPS

- Soft-Grip handle is larger and more ergonomic, allowing high clamping pressure with less effort
- I-beam bar reduces flexing and bowing
- 5" throat depth offers greater versatility



| Model No. | Mfg. No. | Clamping Capacity | Throat Depth | Price /Each |
|-----------|----------|-------------------|----------------|-------------|
| TBR357 | 223212 | 12" (30 cm) | 4 7/8" (12 cm) | 45.10 |
| TBR358 | 223218 | 18" (45 cm) | 4 7/8" (12 cm) | 52.50 |
| TBR359 | 223224 | 24" (60 cm) | 4 7/8" (12 cm) | 57.30 |
| TBR360 | 223230 | 30" (75 cm) | 4 7/8" (12 cm) | 62.10 |

VICES, MAGNETS & CLAMPS

BAR CLAMPS FOR CONSTRUCTION & WOODWORKING

PARALLEL BAR CLAMPS K BODY® REVO™

- Large parallel jaw surfaces are made from non-marring polyamide
- Internal steel frames insure 90° angles
- Large composite handle for better comfort while working
- Bessey® anti-slip system for improved grip and safety
- Swivel fitting ensures clamp sits parallel to the bench top
- 3 3/4" throat depth



| Model No. | Mfg. No. | Clamping Capacity" | Spreading Capacity" | Price /Each |
|-----------|----------|--------------------|---------------------|-------------|
| TKZ904 | KR3.512 | 12 | 9 1/4 - 15 | 70.70 |
| TKZ905 | KR3.524 | 24 | 9 1/4 - 28 1/2 | 76.90 |
| TKZ906 | KR3.531 | 31 | 9 1/4 - 36 1/2 | 83.10 |
| TKZ907 | KR3.540 | 40 | 9 1/4 - 44 | 90.70 |
| TKZ908 | KR3.550 | 50 | 9 1/4 - 53 | 96.40 |
| TKZ909 | KR3.560 | 60 | 9 1/4 - 63 | 105.00 |
| TKZ910 | KR3.582 | 82 | 9 1/4 - 85 | 123.00 |
| TKZ911 | KR3.598 | 98 | 9 1/4 - 100 | 130.00 |

ACCESSORIES FOR PARALLEL CLAMPS

KP FRAMING SYSTEMS

- Blocks align clamps for door and panel construction
- Clamps sit in grooves to make 90° angles
- Four blocks to a set



Model No. TKZ957
Mfg. No. KP Blocks
Price/Set \$30.10

K BODY® EXTENDERS

- Connects two Bessey® clamps together for extended reach
- Durable aluminum construction
- Includes: Extender, nuts, bolts and washers

Model No. TKZ959
Mfg. No. K Body Extender
Price/Each \$25.60



TG PROFESSIONAL SERIES MALLEABLE CAST CLAMPS

- High quality construction
- Perfect for high pressure applications and wide openings
- Two part composite handle



| Model No. | Mfg. No. | Clamping Capacity" | Throat Depth" | Clamping Force (lbs.) | Price /Each |
|-------------------|------------|--------------------|---------------|-----------------------|-------------|
| LIGHT-DUTY | | | | | |
| TKZ912 | TGJ2.5062K | 6 | 2 1/2 | 600 | 24.50 |
| TKZ913 | TGJ2.5122K | 12 | 2 1/2 | 600 | 25.90 |
| TKZ914 | TGJ2.5182K | 18 | 2 1/2 | 600 | 28.30 |
| TKZ915 | TGJ2.5242K | 24 | 2 1/2 | 600 | 31.30 |
| TKZ916 | TGJ2.5302K | 30 | 2 1/2 | 600 | 34.20 |
| TKZ917 | TGJ2.5362K | 36 | 2 1/2 | 600 | 37.30 |
| TKZ918 | TG4.0082K | 8 | 4 | 880 | 36.20 |
| TKZ919 | TG4.0122K | 12 | 4 | 880 | 43.70 |
| TKZ920 | TG4.0162K | 16 | 4 | 880 | 45.70 |
| TKZ921 | TG4.0242K | 24 | 4 | 880 | 59.30 |

| Model No. | Mfg. No. | Clamping Capacity" | Throat Depth" | Clamping Force (lbs.) | Price /Each |
|--------------------|-----------|--------------------|---------------|-----------------------|-------------|
| MEDIUM-DUTY | | | | | |
| TKZ922 | TG4.5122K | 12 | 4 1/2 | 1000 | 49.30 |
| TKZ923 | TG4.5182K | 18 | 4 1/2 | 1000 | 56.40 |
| TKZ924 | TG4.5242K | 24 | 4 1/2 | 1000 | 60.10 |
| TKZ925 | TG4.5302K | 30 | 4 1/2 | 1000 | 67.30 |
| TKZ926 | TG4.5402K | 40 | 4 1/2 | 1000 | 75.80 |
| TKZ927 | TG5.5122K | 12 | 5 1/2 | 1320 | 57.10 |
| TKZ928 | TG5.5182K | 18 | 5 1/2 | 1320 | 69.20 |
| TKZ929 | TG5.5242K | 24 | 5 1/2 | 1320 | 74.60 |
| TKZ932 | TG7.0162K | 16 | 7 | 1320 | 68.90 |
| TKZ933 | TG7.0242K | 24 | 7 | 1320 | 80.70 |
| TKZ936 | TG7.0482K | 48 | 7 | 1320 | 110.00 |

| Model No. | Mfg. No. | Clamping Capacity" | Throat Depth" | Clamping Force (lbs.) | Price /Each |
|-------------------|------------|--------------------|---------------|-----------------------|-------------|
| HEAVY-DUTY | | | | | |
| TKZ937 | TGK4.5162K | 16 | 4 1/2 | 1540 | 64.90 |
| TKZ938 | TGK4.5242K | 24 | 4 1/2 | 1540 | 75.20 |
| TKZ939 | TGK4.5402K | 40 | 4 1/2 | 1540 | 91.10 |
| TKZ940 | TGK4.5502K | 50 | 4 1/2 | 1540 | 99.90 |
| TKZ941 | TGK4.5792K | 79 | 4 1/2 | 1540 | 138.00 |

| Model No. | Mfg. No. | Clamping Capacity" | Throat Depth" | Clamping Force (lbs.) | Price /Each |
|-------------------|------------|--------------------|---------------|-----------------------|-------------|
| DEEP REACH | | | | | |
| TKZ942 | CDS24-10WP | 24 | 10 | 1550 | 167.00 |
| TKZ943 | CDS24-12WP | 24 | 12 | 1550 | 193.00 |
| TKZ944 | CDS24-20WP | 24 | 20 | 990 | 288.00 |

QUICK-GRIP® ONE-HANDED CLAMPS

BAR CLAMPS/SPREADERS

- Quick-Change® jaw quickly converts from clamp to spreader and requires no tools
- Constructed of high-tech reinforced resin for strength and durability
- Exerts up to 250 lbs. of clamping pressure
- Patented pistol grip design enhances comfort and ease of use
- Non-marring pads grip firmly and protect workpiece
- Ideal for clamping/gluing, holding work for sawing/drilling and positioning work for fastening



IRWIN
QUICK-GRIP®

MINI BAR CLAMPS

- 25% smaller than Quick-Change® clamps for smaller projects or for working in confined spaces
- Constructed of high-tech reinforced resin for strength and durability
- Exerts up to 150 lbs. of clamping pressure
- Patented pistol grip design enhances comfort and ease of use
- Non-marring pads grip firmly and protect workpiece
- Ideal for clamping/gluing, holding work for sawing/drilling and positioning work for fastening



| Model No. | Mfg. No. | Clamping Capacity | Spreading Capacity | Throat Depth | Price /Each |
|-----------|----------|-------------------|-------------------------------------|----------------|-------------|
| TAW063 | 506QC | 6" (15 cm) | 7 1/2" - 14 5/8" (195 mm - 360 mm) | 3 1/4" (80 mm) | 33.30 |
| TAW062 | 512QC | 12" (30 cm) | 7 1/2" - 20 5/8" (195 mm - 515 mm) | 3 1/4" (80 mm) | 37.20 |
| TBR688 | 518QC | 18" (45 cm) | 7 1/2" - 26 5/8" (195 mm - 665 mm) | 3 1/4" (80 mm) | 42.80 |
| TBR689 | 524QC | 24" (60 cm) | 7 1/2" - 32 5/8" (195 mm - 820 mm) | 3 1/4" (80 mm) | 46.50 |
| TBR690 | 536QC | 36" (91 cm) | 7 1/2" - 44 5/8" (195 mm - 1120 mm) | 3 1/4" (80 mm) | 55.80 |

| Model No. | Mfg. No. | Clamping Capacity | Spreading Capacity | Throat Depth | Price /Each |
|-----------|----------|-------------------|--------------------|-----------------|-------------|
| TBR758 | 5412 | 12" (30 cm) | - | 2 7/16" (62 mm) | 20.30 |

QUICK-GRIP® ONE-HANDED MICRO BAR CLAMP/SPREADER

- One-handed Quick-Release™ trigger allows for fast and easy positioning
- Perfect size for hobby and craft applications
- Converts to a spreader by reversing the clamp pads

| Model No. | Mfg. No. | Clamping Capacity | Spreading Capacity | Throat Depth | Price /Each |
|-----------|----------|-------------------|--------------------|-----------------|-------------|
| TBR692 | 53006 | 4 1/4" (10 cm) | 8" (20 cm) | 1 3/16" (30 mm) | 8.25 |



IRWIN
QUICK-GRIP

XP™ ONE-HANDED BAR CLAMP & SPREADER

- I-beam bar resists twisting and bowing
- Power Locks™ hold better, allowing for up to 900 lbs. of force
- Quick-Change™ jaw, converts clamp to spreader quickly
- Non-marring pads grip securely
- Quick-Release™ trigger

| Model No. | Mfg. No. | Clamping Capacity | Spreading Capacity | Throat Depth | Price /Each |
|-----------|----------|-------------------|---------------------------------|----------------|-------------|
| TKZ880 | 2021406 | 6" (15 cm) | 7 1/2"-14 5/8" (190 mm-371 mm) | 3 1/4" (83 mm) | 42.90 |
| TKZ881 | 2021412 | 12" (30 cm) | 7 1/2"-20 5/8" (190 mm-523 mm) | 3 1/4" (83 mm) | 47.70 |
| TKZ882 | 2021418 | 18" (45 cm) | 7 1/2"-26 5/8" (190 mm-676 mm) | 3 1/4" (83 mm) | 53.80 |
| TKZ883 | 2021424 | 24" (60 cm) | 7 1/2"-32 5/8" (190 mm-828 mm) | 3 1/4" (83 mm) | 59.50 |
| TKZ884 | 2021436 | 36" (91 cm) | 7 1/2"-44 5/8" (190 mm-1133 mm) | 3 1/4" (83 mm) | 71.10 |
| TKZ885 | 2021450 | 50" (127 cm) | 7 1/2"-58 5/8" (190 mm-1489 mm) | 3 1/4" (83 mm) | 80.70 |



IRWIN
QUICK-GRIP

PARALLEL JAW CLAMPS

- Deep 3 3/4" jaw depth for optimized pressure distribution
- Secure locking system prevents jaws from slipping
- ProTouch handle for an ergonomic grip
- Resin body and jaws prevents marring and glue adhesion
- Up to 1150 lbs. of pressure



IRWIN
QUICK-GRIP

| Model No. | Mfg. No. | Clamping Capacity | Throat Depth" | Price /Each |
|-----------|----------|-------------------|---------------|-------------|
| TLY300 | 2026500 | 24" (60 cm) | 3 3/4 | 74.50 |
| TLY301 | 2026501 | 48" (115 cm) | 3 3/4 | 89.50 |

PARALLEL JAW CLAMPS

- Aluminum die-cast handles have a quick adjustment mechanism for easy sizing
- Serrations in the steel rails engage with a hardened steel insert in the jaw to eliminate slipping
- Clamp jaws are encased in non-marring, glue resistant polypropylene casing
- Clamps up to 2.5 KN of pressure



| Model No. | Clamping Capacity | Throat Width | Throat Depth | Price /Each |
|-----------|-------------------|--------------|--------------|-------------|
| TYB500 | 24" | 1 1/2" | 3 1/3" | 61.75 |
| TYB501 | 50" | 1 1/2" | 3 1/3" | 75.65 |

aurora tools®

VICES, MAGNETS & CLAMPS

QUICK-GRIP® HANDI-CLAMP®

- Quick-Release™ trigger allows for fast and easy positioning and release
- Patented ratcheting mechanism provides adjustable clamping pressure and significantly reduces hand force required to generate clamping pressure
- High-tech resin construction provides strength and durability
- Specially designed jaws hold odd-shaped workpieces



IRWIN
QUICK-GRIP

| Model No. | Mfg. No. | Clamping Capacity | Spreading Capacity | Throat Depth | Price /Each |
|-----------|----------|-------------------|--------------------|----------------|-------------|
| TBQ662 | 59100CD | 1 1/2" (37 mm) | 1 1/2" (37 mm) | 1 1/2" (37 mm) | 5.62 |
| TBR083 | 59200CD | 2" (50 mm) | 2" (50 mm) | 2" (50 mm) | 11.30 |
| TBR085 | 59400CD | 4" (10 cm) | 4" (10 cm) | 3" (75 mm) | 13.60 |

STEEL QUICK CLAMPS

- One hand mechanism for ease of clamping
- Adjustable and reversible: changes from a clamp to a spreader
- Vinyl-covered grips and tips



TGZ582

FULLER

| Model No. | Mfg. No. | Clamping Capacity | Price /Each |
|-----------|----------|-------------------|-------------|
| TGZ581 | 450-0101 | 1" | 1.48 |
| TGZ582 | 450-0102 | 2" | 3.31 |
| TGZ583 | 450-0103 | 3" | 6.28 |

QUICK CLAMPS

- One hand mechanism for ease of clamping
- Adjustable and reversible: Changes from a clamp to a spreader



TGZ585



| Model No. | Mfg. No. | Clamping Capacity | Price /Each |
|-----------|----------|-------------------|-------------|
| TGZ584 | XC2-2 | 1" | 2.28 |
| TGZ585 | XC5-2 | 2" | 3.35 |
| TGZ586 | XC7-2 | 3" | 4.76 |

LOCKING PLIERS - C-CLAMPS W/SWIVEL PADS

- Tempered chrome vanadium steel jaws
- Hardened tension bar with toggle mechanism provides secure locking action
- Smooth screw adjustment for easy and rapid setting
- Meets ANSI standards



aurora tools®

| Model No. | Grip | Length" | Price /Each |
|-----------|-------|---------|-------------|
| TJZ096 | Steel | 6 | 14.00 |
| TJZ097 | Steel | 11 | 23.10 |

PROFESSIONAL ONE HAND EDGE CLAMP

- Twin Spindle: Outer spindle acts as the clamping jaws on work surface while inner spindle applies pressure to the edge
- Large Jaws: Soft non slip pads for positive grip



| Model No. | Clamping Capacity | Clamping Force | Throat Depth | Price /Each |
|-----------|-------------------|----------------|--------------|-------------|
| TKZ945 | 2 1/8" | 500 lbs. | 3" | 112.00 |

C-CLAMPS

- Manufactured from SG iron with over 60000 PSI of tensile strength
- Swiveling pad adapts to the correct angle to apply even pressure on the work piece
- Textured powder coat finish on frame and black oxide finish on spindle increases corrosion resistance



TYB504

aurora tools®

| Model No. | Clamping Capacity | Throat Depth | Min. Proof Test lbs. | Price /Each |
|-----------|-------------------|--------------|----------------------|-------------|
| TYB502 | 2" | 1 5/8" | 800 | 15.65 |
| TYB503 | 3" | 1 11/16" | 1000 | 19.80 |
| TYB504 | 4" | 2 11/32" | 1200 | 24.95 |
| TYB505 | 6" | 3" | 1400 | 31.95 |
| TYB506 | 8" | 3 1/8" | 1700 | 41.90 |
| TYB507 | 10" | 3 1/2" | 2200 | 54.45 |
| TYB508 | 12" | 4" | 2500 | 69.80 |

VICES, MAGNETS & CLAMPS

QUICK-GRIP® C-CLAMPS

- Double-rolled thread for faster clamping and increased durability
- Larger handle for greater clamping pressure with less effort and reduced hand fatigue
- Larger swivel pad reduces marring on work surface and increases stability



IRWIN
QUICK-GRIP®

| Model No. | Mfg. No. | Clamping Capacity | Throat Depth | Price /Each |
|-----------|----------|-------------------|-----------------|-------------|
| TBR751 | 225101 | 1" (25 mm) | 1 3/16" (30 mm) | 2.84 |
| TBR752 | 225102 | 2" (50 mm) | 1 5/16" (33 mm) | 4.10 |
| TBR753 | 225103 | 3" (75 mm) | 2 1/4" (51 mm) | 8.30 |
| TBR754 | 225104 | 4" (10 cm) | 3" (75 mm) | 14.20 |
| TBR755 | 225106 | 6" (15 cm) | 3 1/2" (87 mm) | 21.60 |
| TBR756 | 225108 | 8" (20 cm) | 4" (10 cm) | 31.10 |
| TBQ959 | 225123 | 2" (50 mm) | 3 1/2" (87 mm) | 12.90 |
| TBQ960 | 225134 | 3" (75 mm) | 4 1/2" (12 cm) | 19.30 |

ECONOMY C-CLAMPS

- Reinforced at all stress points designed to last through the toughest application
- Constructed of high quality ductile iron with a heavy-duty steel screw for maximum strength
- Fully enameled for long life



FULLER

| Model No. | Mfg. No. | Max. Opening" | Throat Depth" | Price /Each |
|-----------|----------|---------------|---------------|-------------|
| VE830* | 450-0761 | 1 | 1 | 2.81 |
| VE831* | 450-0762 | 2 | 1 1/2 | 3.79 |
| VE832 | 450-0772 | 2 1/2 | 2 3/8 | 5.30 |
| VE833 | 450-0763 | 3 | 1 3/4 | 6.41 |
| VE834 | 450-0764 | 4 | 2 3/8 | 9.15 |
| VE835 | 450-0765 | 5 | 2 1/2 | 12.10 |
| VE836 | 450-0766 | 6 | 2 3/4 | 15.60 |
| VE837 | 450-0768 | 8 | 3 3/8 | 19.60 |
| VE838 | 450-0769 | 2 1/2 | 4 3/8 | 10.30 |

* Constructed of malleable iron

C-CLAMPS

GENERAL SERVICE PATTERN

- Designed for uses which do not require the throat depth of the square or deep throat pattern

ARMSTRONG
INDUSTRIAL HAND TOOLS

| Model No. | Mfg. No. | Capacity" | Depth of Throat from Center of Screw" | Thread Size" | Length of Screw" | Min. Proof Test lbs. | Wt. lbs. | Price /Each |
|-----------|----------|-----------|---------------------------------------|--------------|------------------|----------------------|----------|-------------|
| U0707 | 78-102 | 2 0 | 1 3/8 | 1/2-13 | 4 7/8 | 7500 | 1.26 | 99.90 |
| U0708 | 78-103 | 3 0 | 1 3/4 | 5/8-11 | 6 3/8 | 8750 | 2.60 | 113.00 |
| U0709 | 78-104 | 4 0 | 2 | 3/4-10 | 7 7/8 | 10000 | 4.13 | 123.00 |
| U0710 | 78-106 | 6 2 | 2 1/4 | 3/4-10 | 7 7/8 | 11250 | 5.90 | 141.00 |
| U0712 | 78-108 | 8 4 | 2 1/4 | 3/4-10 | 7 7/8 | 12500 | 6.90 | 166.00 |
| U0714 | 78-110 | 10 6 | 2 3/8 | 3/4-10 | 7 7/8 | 13750 | 8.00 | 193.00 |
| U0716 | 78-112 | 12 8 | 2 5/8 | 7/8-9 | 10 1/4 | 15000 | 11.61 | 218.00 |
| U0718 | 78-115 | 15 10 | 2 3/4 | 7/8-9 | 10 1/4 | 16250 | 14.95 | 319.00 |
| U0720 | 78-118 | 18 13 | 2 7/8 | 7/8-9 | 10 1/4 | 17500 | 18.21 | 393.00 |



C-CLAMPS

SQUARE THROAT PATTERN, BLACK FINISH

- Designed for those jobs where a super deep throat is required
- Square throat clamps offer up to 89% more throat depth than other patterns, but embody all the strength and durability inherent in a drop forged C-clamp

ARMSTRONG
INDUSTRIAL HAND TOOLS

| Model No. | Mfg. No. | Capacity" | Depth of Throat from Center of Screw" | Thread Size" | Length of Screw" | Min. Proof Test lbs. | Wt. lbs. | Price /Each |
|-----------|----------|-----------|---------------------------------------|--------------|------------------|----------------------|----------|-------------|
| U0722 | 78-303 | 3 0 | 3 1/2 | 1/2-8 | 4 7/8 | 3500 | 2.52 | 73.60 |
| U0723 | 78-304 | 4 0 | 4 1/2 | 3/4-6 | 7 5/8 | 4100 | 4.49 | 71.40 |
| U0724 | 78-306 | 6 0 | 6 1/2 | 3/4-6 | 9 7/8 | 5400 | 8.05 | 110.00 |
| U0725 | 78-308 | 8 0 | 8 1/2 | 3/4-6 | 12 3/8 | 5900 | 13.11 | 124.00 |



DEEP THROAT PATTERN, ZINC-PLATED

- Design and materials are exactly the same as deep throat pattern
- Forcing screw is zinc-plated to resist the adhesion of welding spatter

| Model No. | Mfg. No. | Capacity" | Depth of Throat from Center of Screw" | Thread Size" | Length of Screw" | Min. Proof Test lbs. | Wt. lbs. | Price /Each |
|-----------|----------|-----------|---------------------------------------|--------------|------------------|----------------------|----------|-------------|
| U0740 | 78-431 | 1 1/2 0 | 1 3/8 | 3/8-16 | 3 1/4 | 1400 | 0.37 | 45.30 |
| U0741 | 78-432 | 2 0 | 2 | 1/2-8 | 4 3/4 | 3300 | 1.23 | 46.50 |
| U0742 | 78-433 | 3 0 | 2 3/8 | 1/2-8 | 5 3/4 | 3500 | 2.11 | 54.10 |
| U0743 | 78-434 | 4 0 | 2 3/4 | 3/4-6 | 7 5/8 | 4100 | 2.89 | 67.40 |
| U0744 | 78-436 | 6 0 | 3 5/8 | 3/4-6 | 9 7/8 | 5400 | 4.83 | 86.70 |
| U0745 | 78-438 | 8 0 | 4 1/2 | 3/4-6 | 12 3/8 | 5900 | 6.98 | 110.00 |
| U0746 | 78-440 | 10 3 | 5 3/8 | 3/4-6 | 12 3/8 | 6200 | 9.66 | 130.00 |
| U0748 | 78-442 | 12 4 | 5 3/4 | 7/8-6 | 13 1/2 | 9300 | 12.85 | 166.00 |



VICES, MAGNETS & CLAMPS



AURORA TOOLS® HOLD DOWN CLAMPS

- Commonly used clamps in manufacturing
- Perfect for holding work pieces in place
- Durable steel construction

VERTICAL HOLD-DOWN CLAMPS

- Includes bonded neoprene-tipped spindle and flanged washers
- Open arm provides adjustable spindle location

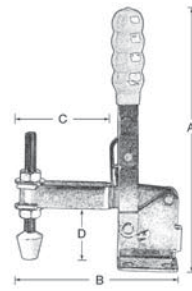

| Model No. | Holding Cap. lbs. | Dimensions" | | | | Base | | | Wt. lbs. | Price /Each |
|-----------|-------------------|-------------|---------|-------|-------|---------|---|--------|----------|-------------|
| | | A | B | C | D | L" | x | W" | | |
| TLV625 | 200 | 4 | 2 1/2 | 1 | 1 | 1 | x | 1 3/4 | 0.34 | 11.60 |
| TLV626 | 375 | 6 | 4 5/8 | 2 3/4 | 1 1/4 | 1 13/16 | x | 1 7/16 | 0.65 | 12.80 |
| TLV627 | 600 | 8 1/8 | 4 13/16 | 3 | 1 3/4 | 1 7/8 | x | 2 1/2 | 1.25 | 15.25 |

aurora tools®



TLV626

HORIZONTAL HOLD-DOWN CLAMPS

- Includes bonded neoprene-tipped spindle and flanged washers
- Low height design is ideal when space is a concern
- Open arm provides adjustable spindle location

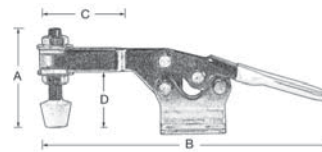

| Model No. | Holding Cap. lbs. | Dimensions" | | | | Base | | | Wt. lbs. | Price /Each |
|-----------|-------------------|-------------|-------|---------|--------|--------|---|--------|----------|-------------|
| | | A | B | C | D | L" | x | W" | | |
| TLV628 | 200 | 1 1/16 | 5 5/8 | 2 1/4 | 1 | 1 7/16 | x | 1 7/16 | 0.28 | 11.60 |
| TLV629 | 500 | 1 13/16 | 6 3/4 | 2 11/16 | 1 5/16 | 1 3/8 | x | 1 1/2 | 0.52 | 13.20 |

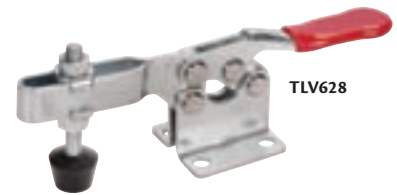

TLV628

LATCH CLAMPS

- Commonly used to hold molds, dies, and jigs together
- Includes latch plate

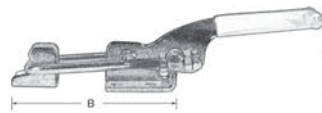

| Model No. | Holding Cap. lbs. | Dimensions" | | Base | | | Wt. lbs. | Price /Each |
|-----------|-------------------|-------------|-------|--------|---|---------|----------|-------------|
| | | A | B | L" | x | W" | | |
| TLV630 | 360 | 1 1/4 | 4 | 1 1/16 | x | 1 | 0.16 | 13.00 |
| TLV631 | 700 | 1 5/8 | 6 7/8 | 1 1/2 | x | 1 11/16 | 0.55 | 16.50 |

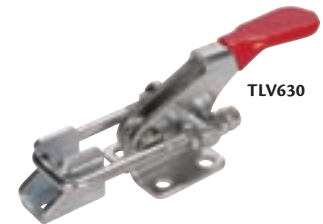

TLV630

STRAIGHT LINE CLAMPS

- Commonly used in assembly operations or with welding jigs

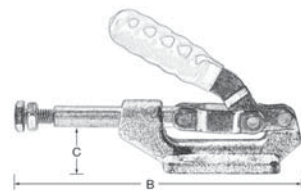

| Model No. | Holding Cap. lbs. | Dimensions" | | | Base | | | Wt. lbs. | Price /Each |
|-----------|-------------------|-------------|-------|-------|-------|---|-------|----------|-------------|
| | | A | B | C | L" | x | W" | | |
| TLV632 | 600 | 3 | 5 1/4 | 3 1/4 | 1 7/8 | x | 2 1/4 | 0.80 | 21.90 |
| TLV633 | 300 | 4 5/16 | 4 1/2 | - | N/A | | | 0.42 | 18.80 |



TLV632

TLV633

AUTO-ADJUST TOGGLE CLAMPS

- Automatically adjust to variations in work piece dimensions
- The integrated clamping force adjustment screw can be used to create an actually applied clamping force from 25 to 550 lbs. (max holding capacity of 700 lbs.)
- The large (2 1/4" x 2 1/2") flanged base is designed for use with 1/4" or M6 fasteners
- The removable non-marring plastic cap is included on the 7/8" diameter swivel pads



| Model No. | Mfg. No. | Opening" | Clamping Force Range (lbs.) | Holding Capacity (lbs.) | Price /Each |
|---------------------------------|-----------|----------|-----------------------------|-------------------------|-------------|
| HORIZONTAL TOGGLE CLAMPS | | | | | |
| TNB028 | STC-HH20 | 13/16 | 25 - 550 | 450 | 28.90 |
| TLV284 | STC-HH50 | 1 9/16 | 25 - 550 | 700 | 31.10 |
| TLV285 | STC-HH70 | 2 3/8 | 25 - 550 | 700 | 31.80 |
| INLINE TOGGLE CLAMPS | | | | | |
| TNB029 | STC-IHH15 | 3/8 | 25 - 550 | 450 | 31.60 |
| TLV286 | STC-IHH25 | 5/8 | 25 - 550 | 700 | 33.10 |



TLV284

TLV286

VICES, MAGNETS & CLAMPS

VERTICAL HOLD-DOWN CLAMPS

The most popular type of hold-down clamp, manufactured in capacities of up to 6000 lbs.

The hold-down bar exhibits a minimum 90° opening angle and can be solid or U-shaped.

Stainless steel units are available for the food industry or corrosive environments.

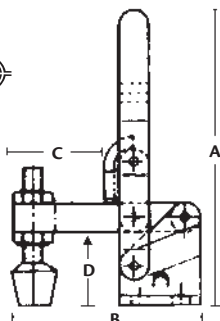

201 SERIES

The smallest vertical clamp available. U-shaped hold-down bar furnished with bonded neoprene-tipped 10-32 spindle assembly (TN140) and flanged washers (TN121).

202 SERIES

200-lb. capacity version of 201 series. Furnished with bonded neoprene-tipped 1/4-20 spindle (TN134) lock nuts and flange washers (TN123).



207 SERIES

Available in solid bar model, including bolt retainer (TN141) 500-lb.-capacity. U-bar model includes two flanged washers (TN125) and accommodates 5/16" spindle (not supplied).

210 SERIES

Heavy-duty clamp holds up to 750 lbs. U-bar model includes two flanged washers (TN124). Bolt retainer supplied with solid bar models (TN142) accommodates any 3/8" spindle (not supplied).



| Model No. | Mfg. No. | Holding Cap. lbs. | Dimensions" | | | | Base | | | Wt. lbs. | Price /Each |
|-----------|----------|-------------------|-------------|---------|-------|---------|---------|---|---------|----------|-------------|
| | | | A | B | C | D | L" | x | W" | | |
| TN059 | 201-U | 100 | 3 1/16 | 2 1/64 | 11/16 | 5/8 | 1 | x | 1 5/16 | 0.15 | 22.10 |
| TN061 | 202-U | 200 | 3 3/4 | 2 3/8 | 1 | 15/16 | 1 | x | 1 9/16 | 0.35 | 22.90 |
| TN065 | 207-S | 500 | 5 1/2 | 3 25/32 | - | 1 9/16 | 1 3/8 | x | 1 3/4 | 0.69 | 31.20 |
| TN064 | 207-U | 375 | 5 1/2 | 3 25/32 | 1 3/8 | 1 9/16 | 1 3/8 | x | 1 3/4 | 0.67 | 30.10 |
| TN066 | 210-U | 600 | 7 1/2 | 5 7/8 | 2 5/8 | 1 11/16 | 1 29/32 | x | 2 17/32 | 1.29 | 44.90 |
| TN067 | 210-S | 750 | 7 1/2 | 5 7/8 | - | 1 11/16 | 1 29/32 | x | 2 17/32 | 1.29 | 49.90 |

TOGGLE-LOCK PLUS™ LATCH CLAMPS

Feature a release lever catch accessory which allows clamps to lock in the closed position only. Supplied with latch plate and equipped with an ergonomic handle grip. Model TV727 same as model TV726 only with greater holding capacity.

| Model No. | Mfg. No. | Holding Cap. lbs. | Dimensions" | | Thread Adjustment" | L" | Base | W" | Drawing Cap." | Wt. lbs. | Price /Each |
|-----------|----------|-------------------|-------------|-------|--------------------|--------|------|-------|---------------|----------|-------------|
| TV726 | 331-R | 700 | 1 15/32 | 6 1/4 | 11/64 | 1 9/16 | x | 1 3/4 | 2 | 0.6 | 59.40 |
| TV727 | 341-R | 2000 | 2 3/4 | 6 1/2 | 9/16 | 2 3/8 | x | 2 3/8 | 2 1/2 | 0.6 | 86.90 |

Equipped with a release lever catch accessory which allow clamps to stay locked in the closed position. Large handle pad improves operation of clamp.

| Model No. | Mfg. No. | Holding Cap. lbs. | Dimensions" | | Thread Adjustment" | L" | Base | W" | Drawing Cap." | Wt. lbs. | Price /Each |
|-----------|----------|-------------------|-------------|---------|--------------------|---------|------|---------|---------------|----------|-------------|
| TV728 | 351-R | 375 | 1 7/16 | 9 11/16 | 5/16 | 1 1/2 | x | 1 15/16 | 4 | 0.8 | 56.30 |
| TV729 | 371-R | 750 | 2 1/4 | 13 | 11/16 | 1 15/16 | x | 1 15/16 | 5 3/8 | 0.6 | 108.00 |



TV726

TV728



HORIZONTAL HOLD-DOWN CLAMPS

Low height design makes clamps outstanding when headroom is a concern. Unlike the handle on the vertical clamp, the horizontal clamp moves in the opposite direction. Hold down bar available in solid or U-shaped format. Some models available in stainless steel on request. Holding capacities to 500 lbs. Larger capacities available.

205 SERIES

The smallest clamps in the horizontal series clamps supplied with nylon spindle assembly (TN126). Flanged washers supplied with U-bar models (TN122).

215 & 225 SERIES

U-bar horizontal clamps provide greater rigidity and overall performance. The 215 Series includes a 1/4-20 bonded neoprene-tipped spindle assembly (TN134) and washers (TN123). The 225 Series includes a 5/16-18 bonded neoprene spindle assembly (TN135) and flanged washers (TN125).

305 SERIES

Feature a handle that can be operated from either side or from behind. U-bar model includes bonded neoprene-tipped spindle (TN140) and flanged washers (TN121).

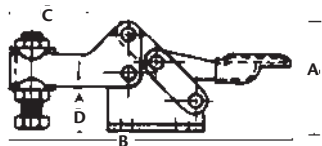

| Model No. | Mfg. No. | Holding Cap. lbs. | Dimensions" | | | | L" | Base | | Wt. lbs. | Price /Each |
|-----------|----------|-------------------|-------------|---------|---------|-------|--------|------|-------|----------|-------------|
| | | | A | B | C | D | | x | W" | | |
| TN062 | 205-U | 60 | 3/4 | 2 21/32 | 3/8 | 5/16 | 15/16 | x | 15/16 | 0.06 | 17.20 |
| TN063 | 205-S | 60 | 3/4 | 2 3/4 | - | 3/8 | 15/16 | x | 15/16 | 0.06 | 16.90 |
| TN068 | 215-U | 200 | 1 1/2 | 5 7/16 | 1 1/4 | 1 | 1 7/16 | x | 1 3/8 | 0.32 | 22.90 |
| TN069 | 225-U | 500 | 1 7/8 | 6 19/32 | 1 11/32 | 1 3/8 | 1 1/2 | x | 1 3/8 | 0.55 | 26.20 |
| TN070 | 305-U | 150 | 1 3/8 | 2 1/4 | 1/2 | 1/2 | 1 1/32 | x | 1 | 0.13 | 21.70 |



LATCH CLAMPS

Commonly used to hold lids, molds, dies and jigs together. Completely adjustable hook grabs latch installed on material or jig to be pulled together, and holds both sides together. Clamps can be bolted or welded into place. Ideal for high vibration applications. Pull bar is threaded for easy adjustment.

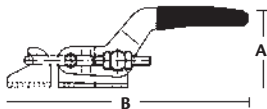

300 SERIES

The over-center toggle locking action of these clamps suits them ideally for holding against heavy forces such as those generated in plastic molding operations, clamping of doors, lids and access covers. Each clamp includes latch plate.



LATCH CLAMPS

| Model No. | Mfg. No. | Holding Cap. lbs. | Dimensions" | | | Thread Adjustment" | Base L" x W" | | | Drawing Cap." | Wt. lbs. | Price /Each |
|-----------|----------|-------------------|-------------|---------|---|--------------------|--------------|-----------|--------|---------------|---------------|-------------|
| | | | A | B | C | | | | | | | |
| TN073 | 323 | 360 | 15/32 | 3 27/32 | | 25/32 | 5/8 | x 1 7/64 | 1 3/16 | 0.15 | 24.40 | |
| TN074 | 324 | 500 | 15/32 | 3 27/32 | | 25/32 | 5/8 | x 1 7/64 | 1 1/2 | 0.25 | 37.60 | |
| TN076 | 331 | 700 | 1 5/8 | 5 5/8 | | 1 | 3/4 | x 1 39/64 | 1 1/4 | 0.56 | 32.50 | |
| TN077 | 341 | 2000 | 2 3/4 | 8 1/4 | | 1 1/2 | 2 3/8 | x 2 33/64 | 2 1/2 | 1.43 | 51.90 | |
| TN081 | 375 | 4000 | 4 | 10 3/8 | | 1/2 | 3 3/8 | x 3 1/8 | 3 1/2 | 2.75 | 116.00 | |

PLIER HOLD-DOWN CLAMPS

Quick action pliers offer excellent workholding capacity, they are portable to many applications and highly versatile. Only normal hand pressure is required to close and lock clamps in place. Clamp thickness may be adjusted by turning the threaded spindle. Once set, the clamp can be used repeatedly at that opening. Standard style clamps open by pulling handles apart. Trigger release style pull the two-way release (up and down) for easy one-handed release.

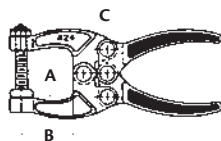

424 SERIES

Has a single 1/4-20 adjustable neoprene-tipped spindle assembly. Clamp opens by manually pulling handles apart.



462 SERIES

Two trigger release clamp includes 3/8-16 steel swivel foot adjustment spindle assembly.



STRAIGHT LINE CLAMPS

Popular in assembly operations or used in conjunction with welding jigs. Straight line clamps provide quick, strong holding force. Most clamps lock in two positions allowing them to be used as a push or pull clamp.

601, 603 & 609 SERIES

These models can be bolted or welded to a flat surface. Plungers extend out to clamp material against a fence or square surface. Model TN103 includes a 8-32 nylon spindle assembly (TN126). Model TN105 plunger is tapped for 5/16-18 adjustment spindle (not provided). Model TN107 plunger is tapped for 5/16-18 neoprene tip or other custom fixture.

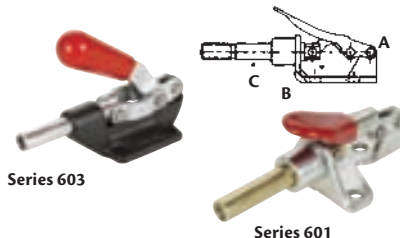

602 & 604 SERIES

Fully retractable locators mount directly through a member by a jam nut on the work side or flush by drilling and tapping the member, a flat surface is not required. Locks in extended or retracted position. When flush-mounted, plunger completely retracts from work area.

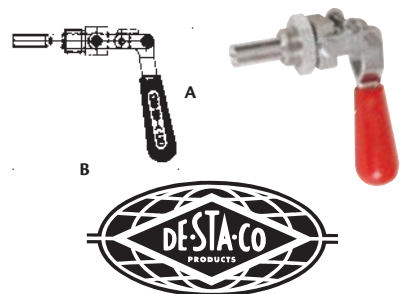

PLIER CLAMPS

| Model No. | Mfg. No. | Holding Cap. lbs. | Clamping Thickness" (A) | Throat Depth" (B) | Overall Length" (C) | Spindle Thread" | Wt. lbs. | Price /Each |
|-----------|----------|-------------------|-------------------------|-------------------|---------------------|-----------------|----------|--------------|
| TN097 | 424 | 200 | 1 | 1 1/8 | 4 1/2 | 1/4 x 20 | 0.31 | 34.60 |
| TN102 | 462 | 700 | 1 3/4 | 2 3/4 | 8 1/2 | 3/8 x 16 | 1.13 | 67.60 |

STRAIGHT LINE CLAMPS

| Model No. | Mfg. No. | Holding Cap. lbs. | Dimensions" | | | Base L" x W" | | Plunger Travel" | Wt. lbs. | Price /Each |
|-----------|----------|-------------------|-------------|---------|-------|--------------|----------|-----------------|----------|--------------|
| | | | A | B | C | | | | | |
| TN103 | 601 | 100 | 1 1/4 | 2 27/32 | 1/2 | 1 5/16 | x 1 1/6 | 5/8 | 0.09 | 22.60 |
| TN104 | 602 | 200 | 3 3/32 | 2 7/16 | - | - | - | 33/4 | 0.25 | 31.90 |
| TN105 | 603 | 600 | 3 1/2 | 4 1/2 | 31/32 | 2 | x 1 7/8 | 1 1/4 | 0.83 | 42.50 |
| TN106 | 604 | 300 | 4 1/16 | 4 15/16 | - | - | - | 1 1/2 | 0.44 | 35.60 |
| TN107 | 609 | 300 | 3 3/8 | 4 7/16 | 31/32 | 3 9/16 | x 2 3/16 | 1 1/4 | 0.88 | 39.50 |

REPLACEMENT SPINDLES & ACCESSORIES

FLAT-TIP BONDED NEOPRENE CAPS

Adjustable spindles provide a cushion between clamps and clamped item. Neoprene tip resists oils and chemicals and has a durometer of 60-70 and an operating temperature of -40°F to 220°F. Each spindle includes two adjusting nuts.

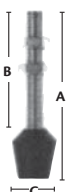

FLANGED WASHERS

Carbon steel replacements for U-bar clamps only.

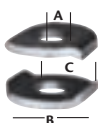

BOLT RETAINERS

Carbon steel replacements for S solid hold-down bars.



NEOPRENE CAPS

Slip-on heads of hex nut spindles, durometer 60-70 and operates between -40°F and 220°F.

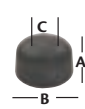

SWIVEL FOOT ADJUSTING SPINDLES

Used primarily for model TN102 plier clamp, but may be used with any clamp with the proper thread size. Steel swivel shoe provides a firm clamp and is suitable for more heavy-duty applications. Includes two adjusting nuts.

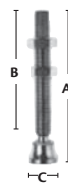

HEX HEAD ADJUSTING SPINDLES

Carbon steel fully threaded adjusting spindles are used in applications where a neoprene or swivel type spindle is not necessary. A neoprene cap foot is available for all sizes. Two adjusting nuts included.

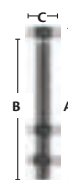

| Model No. | Mfg. No. | Dimensions | | | Thread" | Price /Each |
|--------------------------------------|----------|------------|--------|------|---------|-------------|
| | | A" | B" | C" | | |
| FLAT-TIP BONDED NEOPRENE CAPS | | | | | | |
| TN134 | 202208 | 1 5/8 | 1 1/8 | 5/8 | 1/4-20 | 4.10 |
| TN135 | 225208 | 2 3/16 | 1 9/16 | 3/4 | 5/16-18 | 4.71 |
| TN136 | 235208 | 5 1/2 | 4 3/4 | 7/8 | 3/8-16 | 8.57 |
| TN137 | 424208 | 1 1/2 | 1 1/8 | 5/8 | 1/4-20 | 3.74 |
| TN138 | 507208 | 3 | 2 1/4 | 3/4 | 5/16-18 | 4.80 |
| TN139 | 527208 | 3 1/2 | 2 1/2 | 7/8 | 3/8-16 | 7.10 |
| STEEL SWIVEL FOOT SPINDLE | | | | | | |
| TN133 | 468206 | 3 | 2 | 5/8 | 3/8-16 | 9.59 |
| HEX-HEAD FULL THREAD | | | | | | |
| TN129 | 441203 | 1 15/16 | 1 3/4 | 1/2 | 5/16-18 | 3.34 |
| TN127 | 207203 | 2 3/4 | 2 1/2 | 1/2 | 5/16-18 | 2.51 |
| TN131 | 491203 | 1 1/2 | 1 1/4 | 9/16 | 3/8-16 | 3.14 |
| TN128 | 210203 | 3 | 2 3/4 | 9/16 | 3/8-16 | 2.71 |

| Model No. | Mfg. No. | Dimensions | | | Thread" | Price /Each |
|-----------------------------------|----------|------------|-------|-------|--------------------|-------------|
| | | A" | B" | C" | | |
| FLANGED WASHERS (PER PAIR) | | | | | | |
| TN122 | 105106 | 11/64 | 7/16 | 5/16 | Fits Spindle #8 | 0.54 |
| TN123 | 215105 | 17/64 | 11/16 | 29/64 | 1/4 | 0.66 |
| TN125 | 507107 | 21/64 | 7/8 | 5/8 | 5/16 | 0.80 |
| TN124 | 235106 | 13/32 | 1 | 23/32 | 3/8 | 0.97 |
| BOLT RETAINERS | | | | | | |
| TN141 | 207105 | 1 1/4 | 5/8 | 21/64 | Fits Spindle 5/16" | 3.57 |
| TN142 | 210114 | 1 1/2 | 3/4 | 17/32 | 3/8 | 5.11 |
| NEOPRENE CAPS | | | | | | |
| TN118 | 215119 | 7/16 | - | 5/8 | Fits Spindle 1/4" | 1.20 |
| TN119 | 225119 | 1/2 | - | 5/8 | 5/16 | 1.31 |
| TN120 | 235119 | 17/32 | - | 3/4 | 3/8 | 1.54 |

VICES, MAGNETS & CLAMPS

OFF-SET BENCH VISES

- Heavy-duty industrial grade vise
- V notched hardened jaws for vertical gripping
- Ideal for tall work pieces
- Hardened anvil striking surface used for forming & shaping
- Safety locking plate in base prevents the vise from slippage
- Mount Type: Fixed



aurora tools®

| Model No. | Jaw Width" | Max. Opening" | Throat Depth" | Price /Each |
|-----------|------------|---------------|---------------|-------------|
| TYL103 | 6 | 6 1/2 | 4 | 192.00 |

UTILITY WORKSHOP VISES

- 80 000 PSI Industrial grade ductile iron
- Built in pipe jaws hold round objects
- Hardened anvil striking surface used for forming & shaping
- Safety locking plate in base prevents the vise from slippage
- Mount Type: Swivel



aurora tools®

| Model No. | Jaw Width" | Jaw Opening" | Throat Depth" | Price /Each |
|-----------|------------|--------------|---------------|-------------|
| TYL097 | 6 | 6 1/2 | 3 4/10 | 182.00 |

MULTI-PURPOSE BENCH VISES

- Heavy-duty casting for demanding applications
- Rotating head for gripping at any angle
- Permanent pipe jaws holds round objects
- Hardened anvil striking surface used for forming & shaping
- Safety locking plate in base prevents the vise from slippage
- Mount Type: Swivel



aurora tools®

| Model No. | Jaw Width" | Jaw Opening" | Throat Depth" | Price /Each |
|-----------|------------|--------------|---------------|-------------|
| TYL102 | 5 | 5 1/2 | 3 1/10 | 259.00 |

HEAVY-DUTY FIXED BASE BENCH VISES

- 80 000 PSI Industrial grade ductile iron
- Built in pipe jaws hold round objects
- Hardened anvil striking surface used for forming & shaping
- Safety locking plate in base prevents the vise from slippage



aurora tools®

| Model No. | Jaw Width" | Jaw Opening" | Throat Depth" | Price /Each |
|-----------|------------|--------------|---------------|-------------|
| TYL093 | 4 | 4 1/2 | 2 7/10 | 146.00 |
| TYL094 | 5 | 5 1/2 | 3 3/10 | 215.00 |
| TYL095 | 6 | 6 1/2 | 3 1/2 | 299.00 |
| TYL096 | 8 | 8 1/2 | 4 | 395.00 |

HEAVY-DUTY INDUSTRIAL BENCH VISES

- 90 000 PSI drop forged alloy steel construction for top performance
- Perfect parallel jaw design for secure clamping
- Forged pipe jaws hold up to 2 1/2" pipe (TNB035)
- Precision ground and induction hardened jaws and anvil for dependable and long life of vise
- Long length alloy steel spindle handle for fast and high force clamping
- 360° rotation swivel base for versatile positioning of parts



| Model No. | Mfg. No. | Jaw Width" | Jaw Opening" | Throat Depth" | Pipe Jaw Capacity" | Price /Each |
|-----------|----------|------------|--------------|---------------|--------------------|-------------|
| TNB033 | BV-DF4SB | 4 | 4 1/2 | 2 3/8 | 3/8 - 1 1/4 | 494.00 |
| TNB034 | BV-DF5SB | 5 | 6 1/2 | 3 | 3/8 - 1 1/2 | 604.00 |
| TNB035 | BV-DF6SB | 6 | 7 | 4 | 3/8 - 2 1/2 | 715.00 |

HEAVY-DUTY SWIVEL BASE BENCH VISES

- 80 000 PSI Industrial grade ductile iron
- Built in pipe jaws hold round objects
- Hardened anvil striking surface used for forming & shaping
- Safety locking plate in base prevents the vise from slipping



aurora tools®

| Model No. | Jaw Width" | Jaw Opening" | Throat Depth" | Price /Each |
|-----------|------------|--------------|---------------|-------------|
| TYL098 | 4 | 4 1/2 | 2 1/2 | 119.00 |
| TYL099 | 5 | 5 1/2 | 3 | 164.00 |
| TYL100 | 6 | 6 1/2 | 3 4/10 | 202.00 |
| TYL101 | 8 | 8 3/10 | 3 8/10 | 310.00 |

VICES, MAGNETS & CLAMPS

COMBINATION PIPE & BENCH VISES

- Perfect to handle any work holding jobs
- Tool steel serrated top jaws and pipe jaws
- Suitable for plant maintenance, oil field service, heavy construction



| Model No. | Mfg. No. | Jaw Width" | Jaw Opening" | Throat Depth" | Pipe Jaw Capacity" | Price /Each |
|-----------|----------|------------|--------------|---------------|--------------------|-------------|
| TM838 | C-0 | 3 1/2 | 5 | 4 1/2 | 1/8 - 2 1/2 | 1233.00 |
| TM839 | C-1 | 4 1/2 | 6 | 4 3/4 | 1/8 - 3 1/2 | 1781.00 |
| TM840 | C-2 | 5 | 7 | 5 5/16 | 1/8 - 4 1/2 | 2304.00 |
| TM841 | C-3 | 6 | 9 | 6 5/8 | 1/4 - 6 | 3385.00 |

MULTI-PURPOSE MECHANIC'S VISES

- Jaw opening expands to 9 3/4" when reversed
- Grey iron main castings
- Replaceable, hardened tool steel jaw faces
- Two working anvil surfaces
- Two lock down bolts are furnished
- Swivel base with four mounting lugs allows for 360° swivel



| Model No. | Mfg. No. | Jaw Width" | Jaw Opening" | Throat Depth" | Pipe Jaw Capacity" | Price /Each |
|-----------|----------|------------|--------------|---------------|--------------------|-------------|
| TD672 | 4500 | 5 1/2 | 9 3/4 | 3 3/4 | 1/8 - 3 | 336.00 |

TRADESMAN VISES

- Meets all Government specifications
- Replaceable top and pipe jaws
- Provides greater clamping surface
- Large anvil
- Fully enclosed spindle
- Straight line design
- Mounting template and parts list included with every vise
- Precision thrust bearing creates greater clamping pressure and increased longevity
- 60 000 PSI ductile iron
- Top jaws are reversible - either standard serrated jaws for extra grip on sturdier materials or smooth jaws for more delicate pieces
- 360° swivel base



| Model No. | Mfg. No. | Jaw Width" | Jaw Opening" | Throat Depth" | Pipe Jaw Capacity" | Price /Each |
|-----------|----------|------------|--------------|---------------|--------------------|-------------|
| TD664 | 1745 | 4 1/2 | 4 | 3 1/4 | 1/4 - 2 1/2 | 797.00 |
| TD665 | 1755 | 5 1/2 | 5 | 3 3/4 | 1/4 - 3 | 971.00 |
| TD666 | 1765 | 6 1/2 | 6 1/2 | 4 | 1/4 - 3 1/2 | 1079.00 |
| TD667 | 1780A | 8 | 7 | 4 3/4 | 1/8 - 3 1/2 | 1619.00 |

MECHANIC'S VISES

- Meets all Government specifications
- Replaceable hardened steel serrated jaw inserts and replaceable pipe jaws provide sure grip
- Enclosed, unbreakable box frame, steel channel
- Large anvil
- Swivel base rotated 360° and has double lockdowns ensuring maximum stability
- Straight line design - positions spindle and nut horizontally, reducing thread wear and increasing clamping power
- 30 000 PSI castings for long life and added strength
- Ideal for professional mechanics



| Model No. | Mfg. No. | Jaw Width" | Jaw Opening" | Throat Depth" | Pipe Jaw Capacity" | Price /Each |
|-----------|----------|------------|--------------|---------------|--------------------|-------------|
| TD669 | 744 | 4 | 4 1/2 | 3 7/16 | 1/4 - 2 | 310.00 |
| TD670 | 745 | 5 | 5 1/4 | 3 3/4 | 1/4 - 2 1/2 | 436.00 |
| TD671 | 746 | 6 | 5 3/4 | 4 1/8 | 1/4 - 3 1/2 | 559.00 |

SHOP VISES

- General duty use
- Instant-Action™ vise design ensures immediate engagement of the nut and spindle screw
- Vise rotates 360°
- Rubber pinch point safety guards
- 25 000 PSI castings for long life

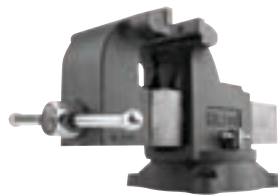

| Model No. | Mfg. No. | Jaw Width" | Jaw Opening" | Throat Depth" | Price /Each |
|-----------|----------|------------|--------------|---------------|-------------|
| VE839 | WS4 | 4 | 4 | 2 3/4 | 199.00 |
| VE840 | WS5 | 5 | 5 | 3 | 239.00 |

UTILITY WORKSHOP VISES

- Durable, versatile, all-around vises
- Handles a variety of applications
- Perfect for use in utility and light duty applications

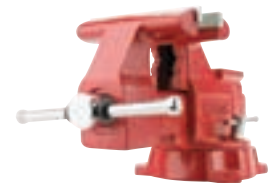

| Model No. | Mfg. No. | Jaw Width" | Jaw Opening" | Throat Depth" | Pipe Jaw Capacity" | Price /Each |
|-----------|----------|------------|--------------|---------------|--------------------|-------------|
| TD677 | 674 | 4 1/4 | 4 | 2 5/8 | 1/8 - 2 | 174.00 |
| TD678 | 675 | 5 1/2 | 5 | 3 7/16 | 1/8 - 2 1/2 | 219.00 |
| TD679 | 676 | 6 1/2 | 5 1/2 | 3 11/16 | 1/8 - 2 1/2 | 299.00 |
| TD680 | 656HD | 6 | 6 | 4 3/16 | 1/8 - 3 | 399.00 |
| TD681 | 648HD | 8 | 7 1/2 | 4 1/2 | 1/8 - 3 | 559.00 |

The ultimate!

210-Piece Socket Set, made of chrome vanadium steel for extra strength and durability.

aurora tools®



Model TLV362
See page 1313

VICES, MAGNETS & CLAMPS

VERSATILE DRILL PRESS VISES

Rugged design and large workload capacity make these vises perfect for the most difficult drilling, tapping or reaming operations.

MODELS VE855, TE622 & E586

- Made of graded cast iron and offers a ground vise bed for a smooth, consistent jaw movement and hardened top U-groove jaws

MODELS VE858 & VE859

- Made of graded cast iron and features precision 90° machining of the vise's sidebodies, which allows them to be used as bases
- Rapid action nut allows for fast loading and unloading of production material and extra tightening capabilities
- Main castings provide extra strength and increased durability



| Model No. | Mfg. No. | Jaw Width" | Jaw Opening" | Jaw Depth" | Price /Each |
|-------------------------|----------|------------|--------------|------------|-------------|
| CONTINUOUS NUT | | | | | |
| VE855 | 1335 | 3 | 2 3/4 | 1 7/8 | 159.00 |
| TE622 | 1345 | 4 | 4 | 2 1/8 | 237.00 |
| VE856 | 1360 | 5 | 5 | 2 1/8 | 324.00 |
| RAPID ACTING NUT | | | | | |
| VE858 | 1445 | 4 1/2 | 4 3/4 | 1 7/8 | 374.00 |
| VE859 | 1460 | 6 | 6 3/4 | 2 1/8 | 510.00 |

VERTI-LOCK® MACHINE VISES

- Jaw widths from 5" up to 8"
- Needle thrust bearing
- Flat bed parallel to 0.0001 per inch
- Ductile steel alloy body parts

SWIVEL BASE

- 360° rotation via two 360° scales
- Calibrated in 1° increments for easy use



WORKSTOP

- Quick, accurate positioning
- Ideal for highly repetitive operations



| Model No. | Mfg. No. | Jaw Width" | Jaw Opening" | Type of Base | Price /Each |
|----------------------|----------|------------|--------------|--------------|-------------|
| MACHINE VISES | | | | | |
| TE166 | 1250N | 5 | 4 1/2 | Stationary | 971.00 |
| TE167 | 1275N | 6 | 7 1/2 | Stationary | 1146.00 |
| TE168 | 1280N | 8 | 7 1/2 | Stationary | 2229.00 |
| SWIVEL BASES | | | | | |
| TE170 | 5S | 5 | - | Swivel | 249.00 |
| TE171 | 6S | 6 | - | Swivel | 286.00 |
| TE172 | 8S | 8 | - | Swivel | 560.00 |

SUPER PRECISION 2 WAY ANGULAR MACHINE VISES

- Perfect vise for grinding, jig boring and shaping jobs
- Jaw plates hardened and ground
- 90° vertical and 180° horizontal indexing
- 360° swivel base and 90° tilting range



| Model No. | Mfg. No. | Jaw Width" | Jaw Opening" | Jaw Depth" | Price /Each |
|-----------|------------|------------|--------------|------------|-------------|
| TJW135 | AMV/SP-50 | 2 | 2 | 1 5/16 | 461.00 |
| TJW136 | AMV/SP-75 | 3 | 3 | 1 5/16 | 747.00 |
| TJW137 | AMV/SP-100 | 4 | 4 | 1 9/16 | 922.00 |
| TJW138 | AMV/SP-125 | 5 | 5 | 2 | 1320.00 |
| TJW139 | AMV/SP-150 | 6 | 6 | 2 | 1656.00 |

BRINK & COTTON VACUUM BASE VISES

- Lightweight and portable
- Mounts on any clean, flat surface
- Cast aluminum body
- 360° swivel base and 180° head tilt



| Model No. | Mfg. No. | Jaw Width" | Jaw Opening" | Type of Base | Price /Each |
|-----------|----------|------------|--------------|--------------|-------------|
| TJW113 | 3VB | 2 3/4 | 2 1/2 | Vacuum | 77.20 |



DRILL PRESS VISES

STANDARD MODELS

- Precision grinding of Model TM798 sides and front side face, permits additional mounting positions for drilling, tapping or reaming
- The body and sides are also ground perfectly parallel and square to further ensure complete jaw alignment
- Combining a smooth moveable jaw plate with a cross-patterned 90° V-groove stationary jaw, the vise is recommended for general use
- Model TM802 utilizes fine pitched ACME-threaded screws with hexagonal heads for tight clamping

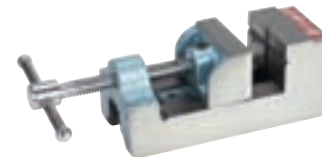

ANGLE MODELS

- Models TM800 and TM804 are mounted on a 90° angle base, sturdily constructed to give workpieces an accurate mount
- The hinge pin hole of the vise body is precision drilled and reamed to avoid lateral play



| Model No. | Mfg. No. | Jaw Width" | Jaw Opening" | Jaw Depth" | Overall Height" | Price /Each |
|------------------------|----------|------------|--------------|------------|-----------------|-------------|
| STANDARD MODELS | | | | | | |
| TM798 | 25 | 2 1/2 | 2 1/2 | 1 1/2 | 3 2/3 | 117.00 |
| TM802 | 30 | 3 | 3 1/8 | 1 3/4 | 3 2/3 | 137.00 |
| ANGLE MODELS | | | | | | |
| TM800 | 25A | 2 1/2 | 2 1/2 | 1 1/2 | 4 1/3 | 127.00 |
| TM804 | 30A | 3 | 3 1/8 | 1 1/4 | 4 1/3 | 192.00 |

CAM ACTION DRILL PRESS VISES

- Holding pressure is adjustable from 400 to 1100 lbs.
- Recessed parallel steel jaw inserts level work, and can be removed to accommodate your jig and fixture components
- The base is designed for clear through drilling applications
- For added durability, bars and locking mechanisms are hardened and ground
- The unique top locking lever can be raised or lowered to tighten or loosen against the workpiece



| Model No. | Mfg. No. | Jaw Width" | Jaw Opening" | Jaw Depth" | Overall Height" | Price /Each |
|-----------|----------|------------|--------------|------------|-----------------|-------------|
| TE161 | 1203 | 3 | 3 | 1 1/4 | 2 3/4 | 267.00 |
| TE162 | 1204 | 4 | 4 11/16 | 1 5/16 | 3 1/4 | 289.00 |
| TE163 | 1206 | 6 | 6 3/16 | 1 13/16 | 3 3/4 | 499.00 |
| TE164 | 1208 | 8 | 8 3/16 | 2 | 4 7/16 | 635.00 |

SUPER PRECISION 3 WAY TILTING MACHINE VISES

- Perfect vise for 3 axis jobs in milling, drilling, grinding, shaping and jig boring
- Jaw plates hardened and ground
- Accurately indexed for 3 way angular work
- 90° vertical indexing
- 360° swivel base and 45° tilting range on either side



| Model No. | Mfg. No. | Jaw Width" | Jaw Opening" | Jaw Depth" | Price /Each |
|-----------|------------|------------|--------------|------------|-------------|
| TJW130 | TLT/SP-50 | 2 | 2 | 5/16 | 635.00 |
| TJW131 | TLT/SP-75 | 3 | 3 | 1 5/16 | 1118.00 |
| TJW132 | TLT/SP-100 | 4 | 4 | 1 9/16 | 1422.00 |



WISE COMBINATIONS

PANA VISE®

PV JR

- More like a tool than a vise, the grooved jaws open to 2 7/8" (73 mm) and are made from fibre reinforced thermal composite alloy
- Jaws are controlled with a fine/coarse adjusting knob, which permits very delicate work
- Head movement is through three planes (360° rotation, 360° swivel and 210° pivot) and is controlled with a single knob
- Base is made of die cast zinc, with a 4 5/16" (109.5 mm) bolt circle countersunk for 1/4" (6.3 mm) flathead bolts (not included)
- 6 3/4" tall (171.4 mm) and weighs 1 1/4 lbs. (0.6 kg)

Model No. TGZ417 Mfg. No. 201
Price/Each \$94.50



STANDARD

- All-purpose work holding unit, perfect for both industrial and home hobbyist applications
- A single knob controls the "tilt, turn and rotate" function of the patented split ball, which allows the head to move easily and conveniently through three planes (360° rotation, 360° swivel and 90° pivot)
- Jaws are 2 1/2" (63.5 mm) wide and open to 2 1/4" (57.1 mm), and the base features a 4 5/16" (109.5 mm) bolt circle
- The combination stands 6 3/4" (171.4 mm) tall, weighs 2 lbs. 11 oz. (1.2 kg)

Model No. WJ595 Mfg. No. 301
Price/Each \$175.00



VACUUM BASE

- A half turn of the mount lever attaches or releases the powerful suction pad and allows rapid set-ups in a variety of locations (for use on smooth, non-porous surfaces only)
- This combination stands 6 1/8" (155.6 mm) tall and weighs 2 lbs. 13 oz. (1.3 kg)

Model No. WJ596 Mfg. No. 381
Price/Each \$235.00



WIDE-OPEN HEAD

- This vise provides a wide gripping head with the full "tilt, turn and rotate" capabilities of the split ball (found in every 300 and 400 series base)
- Unit stands 7 5/16" (185.7 mm) tall and weighs 3 lbs. (1.4 kg)

Model No. WJ597 Mfg. No. 396
Price/Each \$220.00



MULTI-PURPOSE WORK CENTRE

- This is a most versatile combination, perfect for home or hobby needs
- This unit stands 7 7/8" (200 mm) tall and weighs 5 lbs. (2.3 kg)

Model No. WJ598 Mfg. No. 350
Price/Each \$258.00



PALMGREN® DUAL FORCE PRECISION MACHINE VISES

- High quality precision vise
- Wide clamping capacities
- Equipped with dual force anti-lift mechanism
- Vise nut does not extend past the vise body
- Hardened jaw plates and vise bed
- Bed heights matched to +/- 0.0004"
- 80 000 PSI stress relieved ductile iron castings
- Lifetime guarantee
- Jaw Plate: Smooth
- Overall Length: 18-15/16"
- Jaw Deflection: 0.001" @ 4000 lbs.
- Base Type: Slotted



| Model No. | Jaw Width | Jaw Opening | Throat Depth | Price /Each |
|-----------|-----------|-------------|--------------|-------------|
| TY0551 | 5 15/16" | 8 63/64" | 1 3/4" | 1255.00 |
| TY0552 | 8 7/64" | 10 7/16" | 2 13/64" | 2612.00 |

PALMGREN® DUAL FORCE PRECISION DOUBLE STATION MACHINE VISES

- Dual force anti-lift mechanism at both ends of the vise
- 80 000 PSI ductile iron casting
- Can be mounted horizontally or vertically
- One handle operates the two moveable jaws
- Can clamp two of the same size parts
- Clamping force equalization
- Precision ground on all sides
- Height tolerance is within 0.001"
- Different work piece clamping applications
- Lifetime guarantee
- Jaw Plate: Smooth
- Overall Length: 21-7/64"
- Base Type: Slotted



| Model No. | Jaw Width | Jaw Opening | Throat Depth | Price /Each |
|-----------|-----------|-------------|--------------|-------------|
| TY0553 | 5 63/64" | 12 7/16" | 1 3/4" | 3995.00 |

PALMGREN® TRADITIONAL DRILL PRESS VISES

- Vise is ideal for use for drilling, tapping, reaming, spot-facing, counter boring and countersinking operations
- Made from 30 000 PSI tensile strength, fine grain cast iron
- Base and bed parallel to 0.001"
- Centre of base is open for holding work through the body of the vise
- Can be mounted on base, sides or on end for general use
- Lifetime guarantee
- Jaw Plate: Grooved
- Overall Length: 5-1/8"
- Overall Height: 1-13/16"
- Jaw Deflection: 0.002" @ 2000 lbs.
- Base Type: Universal



| Model No. | Jaw Width | Jaw Opening | Throat Depth | Price /Each |
|-----------|-----------|-------------|--------------|-------------|
| TY0554 | 1 1/2" | 1 1/2" | 1" | 139.00 |
| TY0555 | 4" | 4" | 1 3/4" | 370.00 |
| TY0556 | 6" | 6" | 2" | 696.00 |

PALMGREN® SWIVEL VISE BASES

- Allows position to 1 degree increments
- Comes with 11/16" keyways to align the vise to the machine table
- Base Type: Slotted



| Model No. | Overall Length | Overall Height | Price /Each |
|-----------|----------------|----------------|-------------|
| TY0557 | 11" | 2 1/2" | 382.00 |
| TY0558 | 13" | 2 1/2" | 418.00 |

WISE ACCESSORIES

IMPROVE CLAMPING VERSATILITY & SAFETY



WILTON MAGNEFIX VISE JAW CAPS TEMPORARY WORK-HOLDING SYSTEMS

- Designed to protect both the vise jaws and the workpiece from marring and distortion during any clamping application
- Caps are constructed from a hardened aluminum alloy with two built-in circular permanent magnets on the backside which hold the product securely to the vise
- The caps are magnetic towards the vise side to prevent steel filings from attaching themselves to the jaws and keep the clamped part from becoming magnetized

MODEL A - ALUMINUM MAGNEFIX JAW CAPS

- Aluminum alloy design includes six grooves to compensate for the unevenness of the workpiece
- Deeper Vee-Groove ensures more secure clamping of circular work pieces
- Use together with Rubber Magnefix Jaw Caps when clamping taper pins and spherical parts

MODEL F - FIBER FACE MAGNEFIX JAW CAPS

- Aluminum alloy with laminated fiber cover to prevent the absorption of outside materials
- Heat parts rapidly by concentrating heat into part
- Use on workpieces to avoid distortion and clamping marks

MODEL R - RUBBER FACE MAGNEFIX JAW CAPS

- Aluminum alloy with synthetic rubber cover
- Jaw cap conforms to workpiece and grips firmly without slipping while protecting work surface
- Use in combination with aluminum and prism jaw caps to clamp taper pins or tapered workpieces

MODEL P - PRISM MAGNEFIX JAW CAPS

- Jaw construction includes a 120° horizontal Vee-Groove, three vertical Vee-Grooves and a 90° groove for marking out and centre punching
- Ideal for light tapping and thread cutting applications



| Model No. | Mfg. No. | Jaw Width" | Price /Each | Model No. | Mfg. No. | Jaw Width" | Price /Each |
|--|----------|------------|-------------|-----------|----------|------------|-------------|
| STANDARD ALUMINUM MAGNEFIX JAW CAPS | | | | | | | |
| TM830 | A-3 | 3 | 62.80 | TJW079 | A-5.5 | 5 1/2 | 69.90 |
| TM832 | A-4 | 4 | 63.50 | TM835 | A-6 | 6 | 74.70 |
| TM833 | A-4.5 | 4 1/2 | 95.50 | TJW081 | A-6.5 | 6 1/2 | 77.20 |
| TM834 | A-5 | 5 | 68.50 | | | | |
| FIBER FACE MAGNEFIX JAW CAPS | | | | | | | |
| TM844 | F-4 | 4 | 66.50 | TM846 | F-5 | 5 | 69.90 |
| TM845 | F-4.5 | 4 1/2 | 68.50 | TM847 | F-6 | 6 | 74.70 |
| RUBBER FACE MAGNEFIX JAW CAPS | | | | | | | |
| TM856 | R-4 | 4 | 63.50 | TJW092 | R-5.5 | 5 1/2 | 69.90 |
| TM857 | R-4.5 | 4 1/2 | 66.00 | TM859 | R-6 | 6 | 74.70 |
| TM858 | R-5 | 5 | 68.50 | TJW094 | R-6.5 | 6 1/2 | 77.20 |
| PRISM MAGNEFIX JAW CAPS | | | | | | | |
| TM851 | P-4 | 4 | 68.50 | TJW100 | P-5.5 | 5 1/2 | 77.20 |
| TM850 | P-4.5 | 4 1/2 | 69.90 | TM853 | P-6 | 6 | 79.70 |
| TM852 | P-5 | 5 | 74.70 | TJW102 | P-6.5 | 6 1/2 | 82.20 |

TELESCOPIC MAGNETIC RETRIEVERS

- Ideal for reaching behind, underneath or around machinery and/or difficult to reach areas
- Rare earth magnet material
- Max. temperature of 180° F (82° C)



| Model No. | Mfg. No. | Strength lbs. | Diameter" | Length" | Extended Length" | Weight lbs. | Price /Each |
|-----------|----------|---------------|-----------|---------|------------------|-------------|-------------|
| TYO508 | 927 | 7.5 | 1/2 | 17 | 26 1/2 | 0.36 | 25.50 |
| TYO509 | 931 | 12 | 1/2 | 13 | 26 | 0.44 | 40.30 |
| TYO510 | 240N | 2 | 5/16 | 5 1/2 | 25 1/2 | 0.07 | 8.29 |
| TYO511 | 926 | 14 | 5/8 | 23 1/2 | 50 | 0.42 | 54.00 |
| TYO512 | 925 | 7 | 5/8 | 8 | 35 | 0.19 | 36.70 |
| TYO513 | 923 | 5 | 3/8 | 6 1/2 | 32 | 0.14 | 25.00 |
| TYO514 | 924 | 7 | 5/8 | 6 1/2 | 32 | 0.18 | 33.40 |
| TYO515 | 990SM | 20 | 1 1/8 | 16 1/2 | 29 | 0.65 | 82.70 |

VICES, MAGNETS & CLAMPS

MAGNETIC PARTS RETRIEVERS

Remove steel parts from bins, boxes, kegs, tables or floors.

- Durable aluminum housing with comfortable non-slip handle
- Powerful, lightweight permanent magnet
- Easy release of collected parts or scrap



MAG-MATE

SHORT HANDLED VERSION

| Model No. | Holding Capacity lbs. | L" | W" | H" | Price /Each |
|-----------|-----------------------|-------|-------|-------|-------------|
| TGY633 | 7 | 4 1/2 | 2 3/8 | 7 1/2 | 168.00 |
| TGY635 | 11 | 4 1/2 | 2 3/8 | 7 1/2 | 214.00 |

MAGNETIC TRIGGER LIFTS

Hand held lift provides a strong grip on parts with an easy to use trigger release.

- Lightweight aluminum housing
- One hand operation
- Move sheets and parts fast, safely and easily
- Retrieve hot parts from burn tables



MAG-MATE

BURN TABLE/PARTS HANDLING

| Model No. | Holding Capacity lbs. | L" | W" | H" | Price /Each |
|-----------|-----------------------|-------|-------|---------|-------------|
| TGY637 | 55 | 3 3/8 | 2 3/8 | 4 13/16 | 207.00 |

ON/OFF POWER GRIPS

- Powerful rare earth magnet
- Securely grips heavy parts
- Works on flat or pipe
- Locking On/Off handle
- Comfort grip
- Max. temperature of 180° F (82° C)



MAG-MATE

| Model No. | Strength lbs. | Diameter" | Length" | Height" | Weight lbs. | Price /Each |
|-----------|---------------|-----------|---------|---------|-------------|-------------|
| TY0546 | 60 | 2 | 6 | 5 | 1.65 | 173.00 |
| TY0547 | 100 | 3 3/8 | 7 1/2 | 7 3/4 | 5/64 | 347.00 |

ON/OFF MAGNETIC HANGING HOOKS

- Hanging hooks are perfect for temporary holding of lines, hoses, lights, tools and more
- Powerful rare earth magnet
- Locking On/Off handle
- Attaches to flat or round surface with ease



MAG-MATE

| Model No. | Strength lbs. | Diameter" | Length" | Height" | Weight lbs. | Price /Each |
|-----------|---------------|-----------|---------|---------|-------------|-------------|
| TY0548 | 35 | 1 3/4 | 5 3/4 | 2 3/4 | 0.95 | 111.00 |
| TY0549 | 110 | 2 1/2 | 7 5/8 | 4 5/8 | 4.65 | 341.00 |

POWER GRIPS

- Holds against shear force
- Securely grips heavy parts
- Aluminum insulated
- Epoxy encapsulated magnet



MAG-MATE

| Model No. | Length" | Height" | Width" | Holding Value lbs. | Price /Each |
|-----------|---------|---------|--------|--------------------|-------------|
| LS717 | 2 1/8 | 2 | 3/4 | 25 | 56.30 |
| LS718 | 4 | 2 1/4 | 3/4 | 51.5 | 68.80 |
| LS719 | 5 1/4 | 2 3/4 | 1 7/8 | 92.5 | 76.60 |

MAG-MAID MAGNETIC CLEAN-UP TOOLS

- Picks up steel chips, fasteners and scrap from swarf
- To clean, simply pull the plunger handle to the top of the tube and the collected metal falls off
- Powerful rare earth magnet



MAG-MATE

| Model No. | Length" | Diameter" | Wt. lbs. | Price /Each |
|-----------|---------|-----------|----------|-------------|
| TGY638 | 15 | 1 | 1.25 | 118.00 |
| TGY639 | 36 | 1 | 2.75 | 186.00 |

MAGNETIC PRINT HOLDERS

- Ideal for holding papers, prints and charts against steel partitions, machinery and metal desks
- Magnetic strength holds through many layers of paper
- Does not mark or tear paper



MAG-MATE

| Model No. | Pull lbs. | Dia." | Height" | Price /Each |
|-----------|-----------|---------|---------|-------------|
| TGY600 | 7 | 1 13/64 | 11/16 | 6.25 |
| TGY601 | 12 | 1 13/32 | 9/32 | 7.22 |
| TGY602 | 19 | 2 1/32 | 5/16 | 9.38 |

LONG REACH MAGNETIC RETRIEVERS

- Powerful pickup tools
- Durable handle with grip
- Model TGY621 has a 45° angled head



MAG-MATE

| Model No. | Handle Length" | Head Dimensions | Holding Capacity lbs. | Price /Each |
|-----------|----------------|-----------------|-----------------------|-------------|
| TGY621 | 38 | 3 1/4" Dia. | 47.5 | 41.90 |
| TGY622 | 39.72 | 6" x 1 3/8" | 28 | 81.40 |

MAGNETIC STRIPS

- Conforms to any contour
- Holds many times its weight
- Can be cut, drilled or shaped
- Available with or without adhesive backing



| Thick" | Width" | Length' | Max. Pull per Lin. Ft. (lbs.) | Model No. w/o Adhesive | Price /Roll | Model No. w/Adhesive | Price /Roll |
|--------|--------|---------|-------------------------------|------------------------|-------------|----------------------|-------------|
| 1/32 | 1/2 | 200 | 2 | TGY640 | 61.70 | TGY648 | 108.00 |
| 1/32 | 3/4 | 200 | 3 | TGY641 | 92.60 | TGY649 | 145.00 |
| 1/32 | 1 | 100 | 4 | TGY642 | 57.90 | TGY650 | 92.60 |
| 1/32 | 1 | 200 | 4 | TGY643 | 113.00 | TGY651 | 169.00 |
| 1/16 | 1/2 | 100 | 5 | TGY644 | 54.00 | TGY652 | 84.90 |
| 1/16 | 3/4 | 100 | 8 | TGY645 | 69.50 | TGY653 | 104.00 |
| 1/16 | 1 | 50 | 11 | TGY646 | 51.10 | TGY654 | 76.20 |
| 1/16 | 1 | 100 | 11 | TGY647 | 92.60 | TGY655 | 139.00 |

MAGNETIC TOOL HOLDERS

- Mount to walls, work benches, ladders, etc.
- 3/16" mounting holes and screws provided
- TLY308 and TLY309: holes on 16" centres
- Holds a 10-lb. hammer!

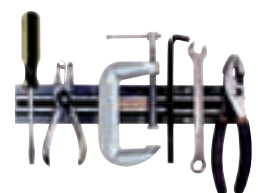

MAG-MATE

| Model No. | Thickness" | H" | L" | Pull lbs. | Wt. lbs. | Price /Each |
|-----------|------------|----|----|-----------|----------|-------------|
| TLY307 | 1 1/8 | 2 | 12 | 120 | 2.0 | 46.60 |
| TLY308 | 1 1/8 | 2 | 18 | 180 | 3.0 | 51.60 |
| TLY309 | 1 1/8 | 2 | 24 | 240 | 4.0 | 59.30 |

VICES, MAGNETS & CLAMPS

MAX-ATTACH™ RARE EARTH MAGNETS

- Utilizes Polymagnet® multi-pole magnetizing technology to produce superior attachment force
- Stronger than conventional magnets

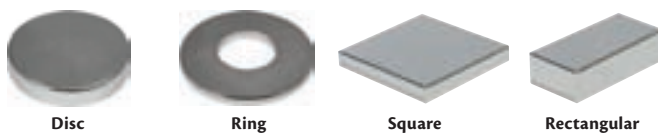

| Model No. | Strength lbs. | Diameter" | Height" | Weight lbs. | Price/Each |
|-------------|---------------|-----------|---------|-------------|------------|
| DISC | | | | | |
| TY0517 | 7.7 | 0.125 | 0.5 | 0.007 | 2.59 |
| TY0518 | 9.3 | 0.187 | 0.5 | 0.037 | 2.91 |
| TY0519 | 8.8 | 0.125 | 0.5 | 0.007 | 2.64 |
| TY0520 | 10.5 | 0.187 | 0.5 | 0.037 | 3.03 |
| TY0521 | 15.3 | 0.062 | 0.75 | 0.007 | 3.00 |
| TY0522 | 18 | 0.125 | 0.75 | 0.015 | 4.50 |
| TY0523 | 16.5 | 0.062 | 1 | 0.013 | 4.64 |
| TY0524 | 37.3 | 0.125 | 1 | 0.027 | 6.82 |
| TY0525 | 38.4 | 0.187 | 1 | 0.040 | 9.70 |
| TY0526 | 77 | 0.125 | 1.5 | 0.060 | 15.00 |
| RING | | | | | |
| TY0527 | 16.3 | 0.125 | 0.75 | 0.014 | 4.38 |
| TY0528 | 16 | 0.125 | 0.75 | 0.011 | 6.02 |
| TY0529 | 33.2 | 0.125 | 1 | 0.026 | 7.29 |
| TY0530 | 67.3 | 0.125 | 1.5 | 0.059 | 16.10 |
| TY0531 | 119 | 0.187 | 2 | 0.128 | 41.10 |

| Model No. | Strength lbs. | Diameter" | Height" | Width" | Weight lbs. | Price/Each |
|--------------------|---------------|-----------|---------|--------|-------------|------------|
| SQUARE | | | | | | |
| TY0532 | 39.8 | 0.125" | 1 | 1 | 0.034 | 10.00 |
| TY0533 | 13.1 | 0.125" | 0.5 | 0.5 | 0.008 | 3.00 |
| TY0537 | 86.4 | 0.125" | 1.5" | 1.5 | 0.076 | 19.70 |
| RECTANGULAR | | | | | | |
| TY0534 | 17.1 | 0.125 | 1 | 0.5 | 0.017 | 4.73 |
| TY0535 | 62.1 | 0.187 | 1.5 | 1 | 0.076 | 21.70 |
| TY0536 | 64.8 | 0.187 | 1.5 | 1 | 0.076 | 22.50 |

LOW PROFILE CUP MAGNETS

Cup magnets are ideal for hanging signs, lights, etc. or retrieving steel items from tanks, vats and bins.



| Model No. | Holding Capacity lbs. | Diameter" | Cup Height" | Magnet I.D." | Hole I.D." | Wt. lbs. | Price /Each |
|-------------------|-----------------------|-----------|-------------|--------------|------------|----------|-------------|
| PLATED CUP | | | | | | | |
| TYG603 | 7 | 1 1/4 | 3/16 | 1/4 | 5/32 | 0.10 | 3.09 |
| TYG605 | 10 | 1 13/32 | 9/32 | 3/8 | 3/16 | 0.38 | 3.79 |
| TYG606 | 13 | 2 1/32 | 5/16 | 7/8 | 3/16 | 0.42 | 5.41 |
| TYG609 | 41 | 2 5/8 | 3/8 | 1 | 9/32 | 0.58 | 7.40 |
| TYG611 | 35 | 2 7/8 | 3/8 | 1 | 1/4 | 0.59 | 10.60 |
| TYG612 | 48 | 3 3/16 | 7/16 | 1 7/32 | 9/32 | 0.60 | 10.80 |
| TYG613 | 95 | 4 29/32 | 1/2 | 1 3/4 | 1/2 | 0.80 | 27.00 |

| Model No. | Holding Capacity lbs. | Diameter" | Cup Height" | Total Height" | Thread Size | Wt. lbs. | Price /Each |
|------------------------------|-----------------------|-----------|-------------|---------------|-------------|----------|-------------|
| PLATED CUP & BOLT | | | | | | | |
| TYG614 | 7 | 1 1/4 | 3/16 | 1 3/16 | 6 - 32 | 0.15 | 8.03 |
| TYG615 | 13 | 2 1/32 | 5/16 | 1 13/16 | 10 - 24 | 0.56 | 11.40 |
| TYG616 | 5 | 2 1/4 | 3/16 | 1 7/8 | 5/16" - 8 | 0.32 | 11.40 |
| TYG617 | 41 | 2 5/8 | 3/8 | 1 15/16 | 3/8" - 16 | 0.60 | 25.80 |
| TYG618 | 48 | 3 3/16 | 7/16 | 1 3/16 | 3/8" - 16 | 0.68 | 32.30 |

| Model No. | Holding Capacity lbs. | Dia." | Cup Height" | Total Height" | Loop I.D." | Wt. lbs. | Price /Each |
|------------------------------|-----------------------|--------|-------------|---------------|------------|----------|-------------|
| PLATED CUP & LOOP | | | | | | | |
| TYG619 | 41 | 2 5/8 | 3/8 | 1 15/16 | 1/2 | 0.60 | 25.80 |
| TYG620 | 48 | 3 3/16 | 7/16 | 1 3/16 | 1/2 | 0.68 | 32.30 |

RECTANGULAR FIXTURE ASSEMBLIES

- A:** Ceramic magnet (TKZ965 is Rare Earth). 400 stainless steel channel. Use 1/4"-20 (m6) fasteners for mounting.
- B:** Nickel plated rare earth magnet. Bright plated steel channel. Use 1/4"-20 (m6) fasteners for mounting.
- C:** Ceramic magnet, 400 stainless steel channel & epoxy filled. Use 10-24 (m5) fasteners for mounting.



| Model No. | Style | Pull lbs. | Thickness" | W" | L" | Ctrs" | Wt. lbs. | Price /Each |
|-----------|-------|-----------|------------|-------|--------|-------|----------|-------------|
| TYG707 | A | 12.5 | 3/8 | 1 3/8 | 3 1/4 | 2 5/8 | 0.10 | 36.00 |
| TKZ965 | A | 43.5 | 3/8 | 1 3/8 | 3 1/4 | 2 5/8 | 0.20 | 68.60 |
| TYG708 | A | 13.5 | 7/16 | 1 3/8 | 3 1/4 | 2 5/8 | 0.30 | 37.40 |
| TYG709 | A | 15.5 | 9/16 | 1 3/8 | 3 1/4 | 2 5/8 | 0.30 | 39.90 |
| TKZ966 | B | 14 | 3/16 | 9/16 | 1 3/4 | 1 1/2 | 0.10 | 6.38 |
| TLY310 | C | 9 | 9/16 | 1 | 2 1/2 | 2 | 0.20 | 24.40 |
| TLY311 | C | 21 | 9/16 | 1 | 4 1/2 | 4 | 0.40 | 41.20 |
| TLY312 | C | 29 | 9/16 | 1 | 6 1/2 | 6 | 0.60 | 49.00 |
| TLY313 | C | 60 | 9/16 | 1 | 12 1/2 | 12 | 1.30 | 85.00 |
| TGY683 | C | 63 | 5/8 | 1 1/2 | 12 | 11 | 1.62 | 95.30 |
| TGY685 | C | 150 | 5/8 | 2 1/2 | 12 | 11 | 2.74 | 118.00 |

CUP MAGNETS W/HOLDERS

- Secure cables, wires, brooms and more to any steel surface



| Model No. | Strength lbs. | Width" | Length" | Clamp Opening" | Price/Each |
|-----------|---------------|--------|---------|----------------|------------|
| TY0538 | 19 | 2.03 | 2-5/16 | 5/8-1-1/4 | 17.40 |
| TY0539 | 11 | 1.41 | 1-17/32 | 3/4-1-1/8 | 12.10 |
| TY0540 | 11 | 1.41 | 1-17/32 | 3/4-1-1/8 | 13.90 |
| TY0541 | 19 | 2.03 | 2-3/16 | 1-1/2-1-7/8 | 15.90 |
| TY0542 | 19 | 2.03 | 2.44 | 1.38 | 16.60 |
| TY0543 | 41 | 2.63 | 1.13 | 0.87-1.25 | 19.80 |
| TY0544 | 7 | 1.24 | 0.44 | 0.38-0.16 | 7.79 |
| TY0545 | 7 | 0.75 | 0.75 | 0.44-1.00 | 7.79 |

RARE EARTH MAGNET MATERIAL

- Extremely powerful magnet is ideal for miniaturized applications
- Operates best at temperatures below 94°C
- High resistance to demagnetization
- Nickel plated finish



| Model No. | Mfg. No. | Dia." | Length" | Holding Capacity lbs. | Price /Each |
|-----------|------------|-------|---------|-----------------------|-------------|
| TYG656 | NE1206NP35 | 0.120 | 0.060 | 0.2 | 0.50 |
| TYG657 | NE1806NP35 | 0.187 | 0.060 | 0.6 | 0.75 |
| TYG658 | NE2225NP35 | 0.220 | 0.250 | 1.5 | 1.47 |
| TYG659 | NE2250NP35 | 0.220 | 0.500 | 1.8 | 1.75 |
| TYG660 | NE2510NP35 | 0.250 | 0.100 | 1.0 | 1.13 |
| TYG661 | NE2512NP35 | 0.250 | 0.125 | 1.2 | 1.28 |
| TYG662 | NE2518NP35 | 0.250 | 0.187 | 1.5 | 1.47 |
| TYG663 | NE2525NP35 | 0.250 | 0.250 | 1.8 | 1.76 |
| TYG664 | NE2550NP35 | 0.250 | 0.500 | 2.1 | 2.97 |
| TYG665 | NE3706NP35 | 0.375 | 0.060 | 1.0 | 1.44 |
| TYG666 | NE3710NP35 | 0.375 | 0.100 | 2.0 | 1.63 |
| TYG667 | NE3712NP35 | 0.375 | 0.125 | 2.6 | 1.66 |
| TYG668 | NE3718NP35 | 0.375 | 0.187 | 4.5 | 3.81 |
| TYG669 | NE3720NP35 | 0.375 | 0.200 | 4.5 | 3.75 |
| TYG670 | NE3725NP35 | 0.375 | 0.250 | 4.6 | 2.72 |
| TYG671 | NE3737NP35 | 0.375 | 0.375 | 5.7 | 2.79 |
| TYG672 | NE3750NP35 | 0.375 | 0.500 | 6.7 | 3.40 |
| TYG673 | NE5006NP35 | 0.500 | 0.060 | 3.0 | 1.66 |
| TYG674 | NE5012NP35 | 0.500 | 0.125 | 4.0 | 1.75 |
| TYG675 | NE5018NP35 | 0.500 | 0.187 | 5.7 | 1.94 |
| TYG676 | NE5020NP35 | 0.500 | 0.200 | 6.0 | 2.09 |
| TYG677 | NE5025NP35 | 0.500 | 0.250 | 6.5 | 3.75 |
| TYG678 | NE5037NP35 | 0.500 | 0.375 | 8.9 | 2.99 |
| TYG679 | NE5050NP35 | 0.500 | 0.500 | 11.2 | 9.00 |

HAND TOOLS & ACCESSORIES

POWER HACKSAWS BLUESTRIPE® BI-METAL HIGH SPEED STEEL EDGE

- The best blades for tough materials
- High-speed steel cutting edge
- Tough alloy steel back
- Will handle irregular shapes and interrupted cuts with ease



| Model No. | Mfg. No. | Length Inch mm x | Width Inch mm x | Thickness Inch mm | Pinhole Dia. Inch mm | TPI | Price /Each |
|-----------|----------|---------------------|--------------------|----------------------|-------------------------|-----|-------------|
| TBB288 | 40099 | 14 350 x | 1 1/8 28.6 x | 0.050 1.25 | 0.281 7 | 10 | 22.50 |
| TBB289 | 40100 | 14 350 x | 1 1/8 28.6 x | 0.050 1.25 | 0.281 7 | 14 | 22.50 |
| TBB290 | 40101 | 14 350 x | 1 3/8 35 x | 0.062 1.6 | 0.281 7 | 6 | 27.30 |
| TBB291 | 40102 | 14 350 x | 1 3/8 35 x | 0.062 1.6 | 0.281 7 | 10 | 27.30 |
| TBB292 | 40105 | 14 350 x | 1 5/8 41 x | 0.075 2 | 0.281 7 | 6 | 33.40 |
| TBB293 | 40113 | 17 425 x | 1 3/8 35 x | 0.062 1.6 | 0.281 7 | 6 | 27.60 |
| TBB303 | 40131 | 24 600 x | 2 1/8 54 x | 0.100 2.5 | 0.39 10 | 3 | 87.90 |
| TBB304 | 40132 | 24 600 x | 2 1/8 54 x | 0.100 2.5 | 0.39 10 | 4 | 87.90 |

BLADES

CARBON

- Carbon steel, all-purpose blades are for cutting mild steel, copper, brass, aluminum and similar materials
- Hardened cutting edge with a tough, flexible back



| Model No. | Mfg. No. | Length" | Width" | Thickness" | Teeth Per Inch | Price /Each |
|-----------|----------|---------|--------|------------|----------------|-------------|
| WJ521 | GF1028 | 10 | 1/2 | 0.025 | 18 | 0.89 |
| WJ522 | 40012 | 10 | 1/2 | 0.025 | 24 | 0.89 |
| WJ523 | 40013 | 10 | 1/2 | 0.025 | 32 | 0.89 |
| WJ525 | GF1218 | 12 | 1/2 | 0.025 | 18 | 0.89 |
| WJ526 | GF1224 | 12 | 1/2 | 0.025 | 24 | 0.89 |
| WJ527 | GF1232 | 12 | 1/2 | 0.025 | 32 | 0.89 |

BLADES

BI-METAL

- Package Type: Carded
- Molybdenum alloy tool steel edge
- Tough and flexible high carbon steel backing
- High tooth hardness and shock resistance
- Two blades per card



Nicholson®

| Model No. | Mfg. No. | Length" | Width" | Thickness" | Teeth Per Inch | Price /Each |
|-----------|----------|---------|--------|------------|----------------|-------------|
| TBH239 | 62811 | 10 | 1/2 | 0.025 | 18 | 3.93 |
| TBH242 | 62826 | 12 | 1/2 | 0.025 | 18 | 4.42 |
| TBH243 | 62830 | 10 | 1/2 | 0.025 | 24 | 3.93 |
| TBH244 | 62832 | 12 | 1/2 | 0.025 | 24 | 4.42 |
| TBH246 | 62839 | 12 | 1/2 | 0.025 | 32 | 4.11 |

POWER HACKSAWS BLADES REDSTRIPE® HIGH SPEED STEEL

- Fully hardened molybdenum high speed steel
- Ideal for long wear life and top performance in sawing a wide range of materials, including stainless and other tough-to-cut alloy steels
- Withstand heavier feed pressures for faster cutting, better than other types of hacksaw blades



| Model No. | Mfg. No. | Length Inch mm x | Width Inch mm x | Thickness Inch mm | Pinhole Dia. Inch mm | TPI | Price /Each |
|-----------|----------|---------------------|--------------------|----------------------|-------------------------|-----|-------------|
| TBB263 | 40046 | 12 300 x | 1 25 x | .050 1.25 | 0.281 7.00 | 10 | 15.90 |
| TBB264 | 40047 | 12 300 x | 1 25 x | .050 1.25 | 0.281 7.00 | 14 | 15.90 |
| TBB265 | 40049 | 14 350 x | 1 25 x | .050 1.25 | 0.281 7.00 | 10 | 19.80 |
| TBB266 | 40050 | 14 350 x | 1 25 x | .050 1.25 | 0.281 7.00 | 14 | 19.80 |
| TBB267 | 40051 | 14 350 x | 1 1/4 32 x | .062 1.6 | 0.281 7.00 | 6 | 25.60 |
| TBB268 | 40052 | 14 350 x | 1 1/4 32 x | .062 1.6 | 0.281 7.00 | 10 | 25.60 |
| TBB274 | 40062 | 17 425 x | 1 1/4 32 x | .062 1.5 | 0.281 7.00 | 6 | 29.10 |
| TBB275 | 40063 | 17 425 x | 1 1/4 32 x | .062 1.5 | 0.281 7.00 | 10 | 29.10 |
| TBB276 | 40064 | 18 450 x | 1 1/4 32 x | .062 1.6 | 0.281 7.00 | 6 | 30.30 |
| TBB277 | 40065 | 18 450 x | 1 1/4 32 x | .062 1.6 | 0.281 7.00 | 10 | 30.30 |
| TBB278 | 40067 | 18 450 x | 1 1/2 38 x | .075 2 | 0.281 7.00 | 4 | 37.60 |
| TBB279 | 40068 | 18 450 x | 1 1/2 38 x | .075 2 | 0.281 7.00 | 6 | 37.60 |
| TBB280 | 40070 | 18 450 x | 1 3/4 45 x | .088 2.25 | 0.281 7.00 | 4 | 52.80 |
| TBB281 | 40071 | 18 450 x | 1 3/4 45 x | .088 2.25 | 0.281 7.00 | 6 | 52.80 |
| TBB282 | 40075 | 21 525 x | 1 3/4 45 x | .088 2.25 | 0.281 7.00 | 4 | 58.80 |
| TBB283 | 40076 | 21 525 x | 1 3/4 45 x | .088 2.25 | 0.281 7.00 | 6 | 58.80 |
| TBB284 | 40081 | 24 600 x | 2 50 x | .100 2.50 | 0.390 10.00 | 4 | 80.40 |
| TBB285 | 40083 | 30 750 x | 2 1/2 63 x | .100 2.50 | 0.390 10.00 | 4 | 121.00 |

BI-METAL WITH GROUND TEETH

- Precision ground, high-speed steel cutting teeth
- Super-efficient tooth shape
- With 170% more high speed steel weld area and a precision ground tooth profile, blade fracture and breakage is greatly reduced



| Model No. | Mfg. No. | Length" | Width" | Thickness" | Teeth Per Inch | Price /Each |
|-----------|----------|---------|--------|------------|----------------|-------------|
| WJ498 | 40327 | 10 | 1/2 | 0.025 | 18 | 1.84 |
| WJ500 | 40330 | 12 | 1/2 | 0.025 | 18 | 1.84 |
| WJ501 | 40331 | 12 | 1/2 | 0.025 | 24 | 1.84 |
| WJ502 | BS11232 | 12 | 1/2 | 0.025 | 32 | 1.84 |
| WJ506 | RS1024 | 10 | 1/2 | 0.025 | 24 | 1.84 |

CARBON

- Package Type: Carded
- Solid high carbon steel
- Tempered to provide hard edge with flexible back
- Economy blade for sawing light to medium-hard materials
- A good balance of wear resistance and mechanical shock absorbing properties
- Two blades per card



Nicholson®

| Model No. | Mfg. No. | Length" | Width" | Thickness" | Teeth Per Inch | Price /Each |
|-----------|----------|---------|--------|------------|----------------|-------------|
| TBH248 | 63220 | 10 | 1/2 | 0.025 | 24 | 1.83 |
| TBH249 | 63256 | 12 | 1/2 | 0.025 | 18 | 1.94 |
| TBH250 | 63268 | 12 | 1/2 | 0.025 | 24 | 1.94 |
| TBH251 | 63280 | 12 | 1/2 | 0.025 | 32 | 1.94 |

CUSHION GRIP HACKSAW FRAMES

- Unique cushioned rubber grip reduces slippage for better control and comfort
- Rugged, sturdy frame built for professional tool users
- High tension technology for tightening the blade to 30,000 PSI
- Blade can be positioned for 45° or 90° cutting
- Patented quick change blade design

Model No. TJ246
Mfg. No. 80965
Price/Each \$41.10



Nicholson®

HIGH TENSION HACKSAW FRAMES

- Quick changing blades
- Adjustable crank handle for tension up to 30,000 PSI torque and micro-adjustment
- Spare blades can be stored inside frame
- Blade can be positioned for 45° or 90° cutting
- End of frame can be used as a jab saw

Model No. TJ557
Mfg. No. 80956
Price/Each \$32.10



Nicholson®

HEAVY-DUTY HACKSAW FRAMES

- High impact, contoured handle
- Adjust to 10" or 12"
- 45° blade adjustment

Model No. TBH296
Mfg. No. 80952
Price/Each \$27.60



Nicholson®

ECONOMY HACKSAW FRAMES

- Adjustable from 10"/250 mm to 12"/300 mm
- Cuts to 2.75"/70 mm in depth
- For DIY and home use

Model No. TJ251
Mfg. No. 80950
Price/Each \$11.30



Nicholson®

GENERAL PURPOSE HACKSAW FRAMES

- Instantly adjustable for 10"/250 mm to 12"/300 mm blades
- Adjusts 90° for vertical or horizontal cuts

Model No. VU145
Mfg. No. 80951
Price/Each \$14.70



Nicholson®

HACKSAWS

- Heavy 16-gauge round steel tubing
- Comfort grip handle
- Adjustable for 10" and 12" blades
- Spring loaded release for quick blade changes
- Cuts at 45° and 90°

Model No. TJZ030
Price/Each \$16.45



aurora tools®

HIGH TENSION HACKSAW FRAMES

- Professional quality high tension frame provides easy to use an efficient adjustment lever
- Rubber handle and thumb hold provides an ergonomic grip (EAM042)
- 4 angled mounting pins allow for both straight and angle cutting, also keeps the blade in place when tension is relieved
- Blade tension is approximately 28 000 PSI (2000 kg/cm²)
- To tension blade, make 3 turn (360°) after first meeting resistance with blade
- Model EAM042 comes with a Starrett Bluestripe bi-metal unique® ground tooth hacksaw blade, model TBD490 comes with a Starrett Greenstripe® bi-metal unique® milled tooth hacksaw blade



TBD490



EAM042

Starrett®

| Model No. | Mfg. No. | Description | Throat Depth | Price /Each |
|-----------|----------|---|----------------|-------------|
| EAM042 | 67818 | 12" closed grip heavy-duty high tension hacksaw frame | 4 3/8" (110mm) | 50.30 |
| TBD490 | 60134 | Heavy-duty adjustable closed grip hacksaw frame | 3 3/4" (95mm) | 32.70 |

LITTLE-NIC® UTILITY HACKSAWS

- Ergonomic cushioned handle
- Gets into small places
- Overall length 10"/250 mm,
- Uses any standard size hacksaw blade

Model No. TBH298
Mfg. No. 80968
Price/Each \$14.20



Nicholson®

JAB SAWS

- Special saw always needed for the difficult jobs: those narrow, hard-to-read areas
- Jab saw will work with any standard size hacksaw blade
- Can replace worn blade easily

Model No. TJ252
Mfg. No. 80969
Price/Each \$9.86



Nicholson®

HAND TOOLS & ACCESSORIES



ALUMINUM FILES – TYPE "A" FLAT

- Special tooth construction eliminates clogging when filing aluminum
- Flat shape
- Double-cut
- All sizes have same number of teeth per inch
- Smooth finish obtained by using shearing cut toward left

Nicholson®

| Model No. | Mfg. No. | Length" | Price /Each |
|-----------|----------|---------|-------------|
| VS433 | 00001N | 6 | 14.40 |
| VS434 | 00024N | 8 | 17.90 |
| VS435 | 00047N | 10 | 19.90 |
| VS436 | 00070N | 12 | 31.20 |



FARMER'S OWN FILES

- General purpose file suited for agricultural use
- Rectangular shape
- Single-cut
- Safe edges
- Length measured exclusive of handle
- Convenient hang up hole

Nicholson®

| Model No. | Mfg. No. | Length" | Price /Each |
|-----------|----------|---------|-------------|
| VS465 | 06637N | 6 | 9.15 |
| VS466 | 06649N | 8 | 11.90 |
| TBG816 | 08922N | 8 | 11.90 |
| VS467 | 06668N | 10 | 17.80 |



CHAIN SAW FILES – SPIRAL CUT (SUPERIOR)

- Round shape
- Spiral cut
- 6" file has straight tang
- Spiral cut enables more material to be removed with each stroke, reducing amount of strokes to produce raw edges

CHAIN SAW FILES – ROUND SMOOTH

- Round shape
- Smooth cut
- 6" files have a straight tang



Nicholson®

Nicholson®

| Model No. | Mfg. No. | Length" | Dia." | Price /Each |
|-----------|----------|---------|-------|-------------|
| TBG761 | 02228B | 8 | 5/32 | 4.97 |
| TBG954 | 23861 | 8 | 13/64 | 4.32 |

| Model No. | Mfg. No. | Length" | Dia." | Price /Each |
|-----------|----------|---------|-------|-------------|
| TBG744 | 01590 | 6 | 1/8 | 4.32 |
| TBG745 | 01630 | 6 | 5/32 | 4.32 |
| TBG750 | 01891 | 8 | 5/32 | 4.32 |
| TBG749 | 01888 | 8 | 7/32 | 4.26 |

CHAIN SAW FILES – FLAT

- Used for cutter-raker type (2 round edges) chain saw
- Rectangular shape

Nicholson®

| Model No. | Mfg. No. | Code No. | Length" | Price /Each |
|-----------|----------|----------|---------|-------------|
| TBG760 | 02215N | 18 | 8 | 11.90 |



SAFETY

GLOVES
TRAFFIC CONTROL
SPILL CONTROL
EYEWEAR

ZENITH®
Safety Products

LONG ANGLE LATHE FILES – FINE

- Specially designed for finishing rapid stock removal on lathe work
- Rectangular shape
- Safe edges
- Cut faster than regular mill files and leave smoother finish



Nicholson®

| Model No. | Mfg. No. | Length" | Price/Each |
|-----------|----------|---------|------------|
| VS510 | 07835N | 8 | 16.40 |
| VS511 | 07842N | 10 | 23.50 |
| VS512 | 07851N | 12 | 31.40 |
| VS513 | 07863N | 14 | 36.90 |

HANDY FILES

- One side is single-cut for use in tool sharpening and smoothing metal surfaces, reverse side is double-cut for general filing and rapid stock removal
- Rectangular shape
- 1 cut edge, 1 safe edge
- Length measured exclusive of handle



Nicholson®

| Model No. | Mfg. No. | Length" | Price/Each |
|-----------|----------|---------|------------|
| TBG796* | 06601 | 8 | 13.10 |
| TBG797 | 06602 | 8 | 12.90 |
| TBG799 | 06686 | 12 | 18.30 |

*Carded

FLAT FILES

- Used by machinists, machinery builders, ship and engine builders, repairmen and others who require rapid removal of metal
- Rectangular in cross section and taper slightly towards point in width
- Double-cut on sides, single-cut on edges
- American pattern, available in bastard, second and smooth-cut



Nicholson®

| Length" | Bastard Cut | | | Second Cut | | | Smooth Cut | | |
|---------|-------------|----------|-------------|------------|----------|-------------|------------|----------|-------------|
| | Model No. | Mfg. No. | Price /Each | Model No. | Mfg. No. | Price /Each | Model No. | Mfg. No. | Price /Each |
| 4 | VS468 | 03367 | 9.85 | VS475 | 03401 | 10.30 | VS481 | 03434 | 12.20 |
| 6 | VS469 | 03467 | 10.20 | VS476 | 03500 | 10.90 | VS482 | 03533 | 12.90 |
| 8 | VS470 | 03566 | 12.70 | VS477 | 03599 | 13.90 | VS483 | 03632 | 14.90 |
| 10 | VS471 | 03665 | 15.70 | VS478 | 03698 | 18.20 | VS484 | 03731 | 19.90 |
| 12 | VS472 | 03764 | 21.50 | VS479 | 03797 | 24.70 | VS485 | 03830 | 26.90 |
| 14 | VS473 | 03863 | 29.90 | VS480 | 03896 | 34.50 | VS486 | 03929 | 37.90 |
| 16 | VS474 | 03980 | 39.60 | - | - | - | - | - | - |

HALF ROUND FILES

- Used on concave, convex and flat surfaces
- Rounded on 1 side, flat on opposite
- Backs of all half-round bastard files are double-cut
- Backs of all half-round second-cut files longer than 6" are double-cut
- Backs of all 4 and 6" files are single-cut
- Backs of all half-round smooth files are single-cut
- Flat sides of all half-round files are double-cut



Nicholson®

| Length" | Bastard Cut | | | Second Cut | | | Smooth Cut | | |
|---------|-------------|----------|-------------|------------|----------|-------------|------------|----------|-------------|
| | Model No. | Mfg. No. | Price /Each | Model No. | Mfg. No. | Price /Each | Model No. | Mfg. No. | Price /Each |
| 4 | VS487 | 04695N | 14.50 | VS494 | 04729N | 16.60 | VS500 | 04762N | 17.50 |
| 6 | VS488 | 04795N | 15.30 | VS495 | 04828NN | 16.60 | VS501 | 04861N | 16.90 |
| 8 | VS489 | 04896N | 18.60 | VS496 | 04927N | 19.50 | VS502 | 04960N | 21.50 |
| 10 | VS490 | 04995N | 23.20 | VS497 | 05026N | 25.10 | VS503 | 05059N | 26.40 |
| 12 | VS491 | 05094N | 29.60 | VS498 | 05125N | 32.40 | VS504 | 05158N | 34.10 |

HAND FILES

- Rectangular shape
- Double-cut
- 1 safe edge
- Same coarseness as flat files of corresponding lengths

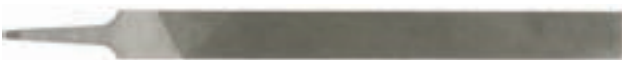

Nicholson®

| Length" | Bastard Cut | | | Second Cut | | | Smooth Cut | | |
|---------|-------------|----------|-------------|------------|----------|-------------|------------|----------|-------------|
| | Model No. | Mfg. No. | Price /Each | Model No. | Mfg. No. | Price /Each | Model No. | Mfg. No. | Price /Each |
| 4 | TBG782 | 05652N | 11.10 | TBG783 | 05675N | 11.10 | - | - | - |
| 6 | TBG785 | 05738N | 11.40 | TBG786 | 05771N | 12.40 | TBG787 | 05804N | 12.90 |
| 8 | TBG788 | 05853N | 12.70 | QF890 | 05886N | 15.20 | TBG789 | 05919N | 15.60 |
| 10 | TBG790 | 05968N | 18.90 | - | - | - | TBG791 | 06034N | 22.20 |
| 12 | TBG792 | 06084N | 24.90 | TBG793 | 06117N | 26.80 | TBG794 | 06150N | 28.60 |

KNIFE FILES

- Used primarily by tool and die makers with work having acute angles
- Triangular shape
- Double-cut on sides, single-cut on sharp edge
- Knife files are supplied with safe backs



Nicholson®

| Length" | Bastard Cut | | | Second Cut | | | Smooth Cut | | |
|---------|-------------|----------|-------------|------------|----------|-------------|------------|----------|-------------|
| | Model No. | Mfg. No. | Price /Each | Model No. | Mfg. No. | Price /Each | Model No. | Mfg. No. | Price /Each |
| 4 | TBG801 | 06711 | 18.60 | TBG802 | 06742 | 19.70 | TBG803 | 06773 | 21.10 |
| 6 | TBG804 | 06804 | 21.30 | TBG805 | 06836 | 23.50 | TBG806 | 06867 | 26.30 |
| 8 | TBG807 | 06898 | 25.40 | TBG808 | 06930 | 27.50 | TBG809 | 06961 | 28.60 |
| 10 | TBG810 | 06992 | 29.90 | TBG811 | 07023 | 34.40 | TBG812 | 07054 | 36.50 |
| 12 | TBG813 | 07085 | 36.90 | - | - | - | - | - | - |

HAND TOOLS & ACCESSORIES



MILL FILES – 1 & 2 ROUND EDGES

- Round edges are used where rounding gullets are preferred, as compared to sharp corners or squared gullets
- Rectangular shape
- Single-cut on sides and edges
- Bastard-cut
- Same as regular mill files except they have 1 or 2 round edges



Nicholson®

| Length" | One Round Edge | | | Two Round Edge | | |
|---------|----------------|----------|-------------|----------------|----------|-------------|
| | Model No. | Mfg. No. | Price /Each | Model No. | Mfg. No. | Price /Each |
| 8 | V5535 | 09099N | 12.10 | TBG817 | 09389N | 13.70 |
| 10 | V5536 | 09179N | 15.60 | TBG818 | 09469N | 16.70 |
| 12 | V5537 | 09227N | 19.30 | - | - | - |

MILL FILES

- Used for sharpening mill or circular saws
- Also for draw-filing and finishing metals
- Rectangular shape
- Single-cut on sides and edges
- 2 square edges
- All sizes taper slightly in width



Nicholson®

| Length" | Bastard Cut | | | Second Cut | | | Smooth Cut | | |
|---------|-------------|-----------|-------------|------------|----------|-------------|------------|----------|-------------|
| | Model No. | Mfg. No. | Price /Each | Model No. | Mfg. No. | Price /Each | Model No. | Mfg. No. | Price /Each |
| 4 | V5518 | 08243N | 6.99 | - | - | - | V5529 | 08306N | 10.70 |
| 6 | V5519 | 08354N | 6.99 | V5525 | 08385N | 10.20 | V5530 | 08416N | 10.80 |
| 8 | V5520 | 08497N | 8.37 | V5526 | 08529N | 11.30 | V5531 | 08560N | 12.70 |
| 10 | V5521 | 08642N | 10.80 | V5527 | 08673N | 14.70 | V5532 | 08704N | 15.30 |
| 12 | V5522 | 08737N | 17.70 | V5528 | 08768N | 19.30 | V5533 | 08799N | 21.20 |
| 12 | TBH214 | 021842HN* | 19.40 | - | - | - | - | - | - |
| 14 | V5523 | 08832N | 23.80 | - | - | - | V5534 | 08894N | 29.20 |
| 16 | V5524 | 08925N | 34.10 | - | - | - | - | - | - |

*Indicates ergonomic handle

MAGICUT® FILES – FLAT

- Used by machinists as all-purpose file to remove stock rapidly and to leave a smooth finish
- Tapered point in width
- File features a pattern of narrow chip breakers created by steep and angled serrations for rapid removal and smoother finish



Nicholson®

| Model No. | Mfg. No. | Length" | Price/Each |
|-----------|----------|---------|------------|
| V5514 | 07894 | 8 | 14.20 |
| V5515 | 07917 | 10 | 18.20 |
| V5516 | 07941 | 12 | 24.20 |
| V5517 | 07965 | 14 | 32.90 |

SQUARE FILES

- Used on slots, keyways and general surface filing
- Square shape
- Double-cut
- Tapered slightly towards point
- Larger sizes frequently preferred to corresponding flat files because of heavier section and 4 filing surfaces



Nicholson®

| Length" | Dia." | Bastard Cut | | | Second Cut | | | Smooth Cut | | |
|---------|-------|-------------|----------|-------------|------------|----------|-------------|------------|----------|-------------|
| | | Model No. | Mfg. No. | Price /Each | Model No. | Mfg. No. | Price /Each | Model No. | Mfg. No. | Price /Each |
| 4 | 5/32 | V5557 | 12790 | 10.50 | - | - | - | V5568 | 12857 | 12.60 |
| 6 | 1/4 | V5558 | 12967 | 10.90 | - | - | - | V5569 | 13033 | 13.70 |
| 8 | 5/16 | V5559 | 13081 | 13.40 | V5565 | 13114 | 15.10 | V5570 | 13147 | 16.60 |
| 10 | 3/8 | V5560 | 13196 | 17.20 | V5566 | 13229 | 20.20 | V5571 | 13262 | 21.60 |
| 12 | 1/2 | V5561 | 13310 | 24.80 | V5567 | 13343 | 27.70 | V5572 | 13376 | 31.30 |
| 14 | 5/8 | V5562 | 13425 | 32.80 | - | - | - | - | - | - |

ROUND FILES

- Primarily used to file circular openings or concave surfaces
- Round shape
- All 4, 5, 6, 8, 10, 12" files are single-cut
- 14" bastard file is double-cut
- Tapered slightly towards point



Nicholson®

| Length" | Dia." | Bastard Cut | | | Second Cut | | | Smooth Cut | | |
|---------|-------|-------------|----------|-------------|------------|----------|-------------|------------|----------|-------------|
| | | Model No. | Mfg. No. | Price /Each | Model No. | Mfg. No. | Price /Each | Model No. | Mfg. No. | Price /Each |
| 4 | 1/8 | V5538 | 11526N | 7.76 | V5545 | 11559N | 8.53 | V5552 | 11592N | 9.39 |
| 5 | 3/16 | V5539 | 11637N | 7.76 | - | - | - | - | - | - |
| 6 | 1/4 | V5540 | 11716N | 7.95 | V5547 | 11748N | 8.99 | V5553 | 11781N | 9.63 |
| 8 | 5/16 | V5541 | 11904 | 9.38 | V5548 | 11936 | 10.90 | V5554 | 11969 | 12.10 |
| 10 | 3/8 | V5542 | 12019 | 12.10 | V5549 | 12051 | 14.30 | V5555 | 12084 | 15.70 |
| 12 | 1/2 | TBG829 | 12131 | 17.80 | - | - | - | - | - | - |
| 12 | 1/2 | V5543 | 12134 | 16.80 | V5550 | 12166 | 19.20 | V5556 | 12199 | 21.10 |
| 14 | 5/8 | V5544 | 12248 | 24.10 | - | - | - | - | - | - |

TAPER FILES – REGULAR

- Triangular shape
- Edges set and cut for filing gullets between saw teeth
- Tapers slightly towards the point



| Model No. | Mfg. No. | Length" | Price /Each |
|-----------|----------|---------|-------------|
| V5576 | 13807M | 6 | 7.95 |
| V5578 | 13875M | 8 | 12.30 |
| V5579 | 13930N | 10 | 16.10 |

Nicholson®

TAPER FILES – SLIM

- Triangular shape
- Edges set and cut for filing gullets between saw teeth



| Model No. | Mfg. No. | Length" | Price /Each |
|-----------|----------|---------|-------------|
| V5582 | 14162M | 5 | 5.83 |
| V5583 | 14224M | 6 | 6.37 |
| V5584 | 14255M | 7 | 8.12 |
| V5585 | 14290M | 8 | 9.56 |
| V5586 | 14341N | 10 | 13.40 |

TAPER FILES – EXTRA SLIM

- Triangular shape
- Edges set and cut for filing gullets between saw teeth



| Model No. | Mfg. No. | Length" | Price /Each |
|-----------|----------|---------|-------------|
| V5587 | 14547M | 4 | 6.46 |
| V5589 | 14599M | 5 | 6.39 |
| V5590 | 14665M | 6 | 6.77 |
| V5591 | 14698N | 7 | 8.12 |
| V5592 | 14729N | 8 | 9.46 |

THREE SQUARE FILES

- For general use by machinists for filing internal angles more acute than right angles, clearing out square corners and filing taps and gutters
- Triangular shape
- Double-cut
- Sharp corners are slightly set and cut
- Cut to the point



Nicholson®

| Length" | Bastard Cut | | | Second Cut | | | Smooth Cut | | |
|---------|-------------|----------|-------------|------------|----------|-------------|------------|----------|-------------|
| | Model No. | Mfg. No. | Price /Each | Model No. | Mfg. No. | Price /Each | Model No. | Mfg. No. | Price /Each |
| 6 | TBG845 | 15925N | 13.80 | WK741 | 15958N | 14.60 | QH788 | 15991N | 15.60 |
| 8 | TBG846 | 16036N | 15.50 | TBG847 | 16069N | 18.50 | QF613 | 16102N | 19.60 |
| 10 | TBG848 | 16147N | 19.30 | TBG849 | 16180N | 20.90 | TBG850 | 16213N | 22.10 |

WARDING FILES

- Used primarily by locksmiths in repairing and filing ward notches in keys
- Thin rectangular shape
- Double-cut on sides, single-cut on edges
- Also suited for use in narrow spaces where other files will not fit



Nicholson®

| Length" | Bastard Cut | | | Second Cut | | | Smooth Cut | | |
|---------|-------------|----------|-------------|------------|----------|-------------|------------|----------|-------------|
| | Model No. | Mfg. No. | Price /Each | Model No. | Mfg. No. | Price /Each | Model No. | Mfg. No. | Price /Each |
| 4 | VS827 | 16507N | 12.60 | VS831 | 16540N | 13.70 | VS835 | 16573N | 14.90 |
| 6 | VS828 | 16663N | 13.60 | VS832 | 16696N | 15.40 | VS836 | 16729N | 16.90 |
| 8 | VS829 | 16761N | 17.10 | VS833 | 16794N | 19.60 | VS837 | 16827N | 21.60 |

CABINET RASPS

- Used by cabinetmakers and woodworkers
- Half-round
- Single-cut on edges
- Curved side of rasps similar to half-round rasps but has larger radius



Nicholson®

| Regular (Second cut) | | | |
|----------------------|----------|---------|-------------|
| Model No. | Mfg. No. | Length" | Price /Each |
| VS599 | 17615N | 8 | 29.10 |
| VS600 | 17683N | 10 | 31.90 |
| VS601 | 17751N | 12 | 41.20 |

PATTERN MAKER'S CABINET RASPS

- Used primarily by cabinetmakers
- Half-round shape
- Narrow pattern, cut edges
- Used when smooth wood finish is required



Nicholson®

| Model No. | Mfg. No. | Length" | Code No. | Type | Price /Each |
|-----------|----------|---------|----------|------------|-------------|
| VS602 | 18846N | 10 | 49 | Second cut | 61.20 |
| VS603 | 18861N | 10 | 50 | Smooth cut | 72.90 |

WOOD RASPS – ROUND BASTARD

- Used for same purpose as regular wood rasps in places for which their shapes make them particularly effective
- Round shape
- Bastard-cut
- Made from same size steel as round files



Nicholson®

| Model No. | Mfg. No. | Length" | Dia." | Price/Each |
|-----------|----------|---------|-------|------------|
| TBG875 | 19846 | 8 | 5/16 | 21.20 |
| TBG876 | 19875 | 10 | 3/8 | 31.50 |

WOOD RASPS – HALF ROUND

- Used by woodworkers, hobbyists and plumbers
- Half-round shape
- Single-cut file teeth on edge
- For use on wood and soft metals



Nicholson®

| Bastard cut | | | |
|-------------|----------|---------|-------------|
| Model No. | Mfg. No. | Length" | Price /Each |
| TBG870 | 19394N | 8 | 19.70 |
| UQ089 | 19427N | 10 | 25.30 |
| TBG871 | 19460N | 12 | 39.20 |
| TBG872 | 19493N | 14 | 49.90 |

aurora tools®

THE INDESTRUCTIBLE!



3 YEAR LIMITED WARRANTY
GRANTABLE & TRANSFERABLE

Model TYB497
See page 1365

- ✓ Will not break, bend or split even after repeated overstrikes
- ✓ Ergonomic rubber grip absorbs impact, reducing user fatigue

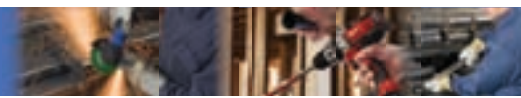

7-PIECE MACHINIST FILE SET

- General purpose file kit for machine shop
- 10"/250 mm flat bastard file
- 10"/250 mm flat smooth file
- 10"/250 mm half-round bastard file
- 10"/250 mm mill bastard file
- 10"/250 mm round bastard file
- 10"/250 mm square bastard file
- 7"/175 mm slim taper file

Model No. TBG943
Mfg. No. 22024NN
Price/Each \$110.00



Nicholson®

8-PIECE MACHINIST FILE SET

- 10"/250 mm mill bastard file
- 10"/250 mm half-round bastard file
- 10"/250 mm flat bastard file
- 10"/250 mm flat smooth file
- 10"/250 mm square bastard file
- 10"/250 mm round bastard file
- 7"/175 mm slim taper file
- 10"/250 mm file cleaner (card)
- Complete set of 7 files and file cleaner (card) fits easily and securely into a rugged, compact pouch

Model No. QH790
Mfg. No. 22025NN
Price/Each \$149.00



Nicholson®

6-PIECE AMERICAN PATTERN FILE SET

- 4"/100 mm Warding file
- 4"/100 mm Half-Round file
- 4"/100 mm Round file,
- 4"/100 mm Hand file,
- 4"/100 mm Square file
- 4"/100 mm Slim taper file,
- All files come with handles and packed in a plastic pouch

Model No. TBG947
Mfg. No. 22062NN
Price/Each \$66.50



Nicholson®

5-PIECE GENERAL PURPOSE SET

- General purpose file kit for home and professional use
- 10"/250 mm half-round bastard file
- 10"/250 mm mill bastard file
- 8"/200 mm mill bastard file
- 8"/200 mm mill smooth file
- Set of 5 files fits easily and securely into rugged, compact pouch

Model No. TBG946
Mfg. No. 22040NN
Price/Each \$66.10



Nicholson®

3-PIECE ERGONOMIC FILE SET

- Rubber-coated ergonomic handles for better comfort and control
- Basic selection for home and professional use
- 6"/150 mm mill bastard file
- 6"/150 mm half-round bastard file
- 6"/150 mm round bastard file

Model No. TBH216
Mfg. No. 22015HNN
Price/Each \$35.30

Nicholson®



5-PIECE ERGONOMIC FILE SET

- Rubber-coated ergonomic handles for better comfort and control
- General purpose selection for home and professional use
- 6"/150 mm slim taper file
- 8"/200 mm flat bastard file
- 8"/200 mm mill bastard file
- 10"/250 mm mill bastard file
- 10"/250 mm half-round bastard file

Model No. TBH218
Mfg. No. 22040HNN
Price/Each \$72.40

Nicholson®



9-PIECE ERGONOMIC FILE SET

- Rubber-coated ergonomic handles for better comfort and control
- Broad selection for home and professional use
- 6"/150 mm XXslim taper file
- 6"/150 mm slim taper file
- 8"/200 mm half-round bastard file
- 8"/200 mm flat bastard file
- 10"/250 mm round bastard file
- 10"/250 mm half-round bastard file
- 10"/250 mm mill bastard file
- 10"/250 mm flat bastard file
- 12"/300 mm mill bastard file

Model No. TBH217
Mfg. No. 22030HNN
Price/Each \$179.00

Nicholson®



3-FILE PACK

- For home and professional use
- Pack contains files for every purpose
- 6"/150 mm slim taper file
- 6"/150 mm round file
- 6"/150 mm mill bastard file
- Plastic pouch lists suggested uses for each file
- Pack measures 3 1/2" (88 mm) x 9 1/2" (237 mm) with hang up hole

Model No. TBG941
Mfg. No. 22015NN
Price/Each \$24.90

Nicholson®



9-PIECE MAINTENANCE FILE SET

- For home and professional use
- 10"/250 mm flat bastard file
- 10"/250 mm flat smooth file
- 10"/250 mm mill bastard file
- 10"/250 mm half-round bastard file
- 10"/250 mm round bastard file
- 8"/200 mm flat smooth file
- 8"/200 mm half-round bastard file
- 8"/200 mm four-in-hand file
- 6"/150 mm slim taper file
- Complete set of 9 files fits easily and securely into rugged, compact pouch

Model No. TBG944
Mfg. No. 22030NN
Price/Each \$153.00

Nicholson®



SCREW-ON HANDLES – PLASTIC

- Screw-on design fits most popular files for professional or home handymen
- Handle made of strong high-impact material, contoured to fit hand for straight, lathe and draw filing
- Non-slip textured finish for easier grip



Nicholson®

SELECTION CHART

| Item | Size - | 4" | 5" | 6" | 8" | 10" | 12" | 14" | 16" |
|-------------------|--------|-----|-----|-----|-----|-----|-----|-----|-----|
| Mill | PH3 | - | PH4 | PH5 | PH5 | PH6 | PH7 | PH8 | |
| Flat | PH3 | - | PH4 | PH5 | PH5 | PH6 | PH7 | PH8 | |
| Hand | PH3 | - | PH4 | PH5 | PH6 | PH7 | PH8 | - | |
| Half Round | PH3 | - | PH4 | PH5 | PH6 | PH7 | PH8 | PH8 | |
| Warding | PH3 | - | PH4 | PH4 | PH5 | - | - | - | |
| Knife | PH3 | - | PH4 | PH5 | PH5 | PH6 | - | - | |
| Round | PH1 | PH2 | PH3 | PH4 | PH4 | PH5 | PH7 | PH7 | |
| Square | PH1 | PH2 | PH3 | PH4 | PH4 | PH5 | PH6 | - | |
| Triangular | PH1 | PH2 | PH3 | PH4 | PH5 | PH6 | PH7 | - | |
| Cantsaw | - | - | PH4 | PH5 | PH6 | - | - | - | |
| Crosscut | - | - | - | PH5 | PH6 | - | - | - | |
| Tanged Horse Rasp | - | - | - | - | - | PH8 | PH8 | - | |
| Platers Special | - | - | - | - | - | - | PH8 | - | |

| Model No. | Mfg. No. | Handle No. | Price /Each | Model No. | Mfg. No. | Handle No. | Price /Each |
|-----------|----------|------------|-------------|-----------|----------|------------|-------------|
| VS792 | 21484 | PH1 | 5.37 | VS796 | 21513 | PH5 | 5.54 |
| VS793 | 21493 | PH2 | 5.37 | VS797 | 21514 | PH6 | 5.66 |
| VS794 | 21502 | PH3 | 5.35 | VS798 | 21515 | PH7 | 5.79 |
| VS795 | 21512 | PH4 | 5.49 | VS799 | 21516 | PH8 | 5.98 |

THREAD RESTORING FILES

- Used to restore damaged or worn external threads on bolts, pipes, etc.
- Each thread restoring file will work with 8 different thread sizes
- Available in 3 sizes and in a convenient 4-piece set
- Caps are colour coded
- Files are made in U.S.A.



Nicholson®

| Model No. | Mfg. No. | Description | Price /Each |
|-----------|----------|---|-------------|
| TBG955 | 33001 | Regular Bolt; 11-12, 13-14, 16-18, 20-24 TPI | 19.90 |
| TBG956 | 33007 | Ex. Fine/Ex. Coarse Bolt; 9-10, 12-16, 20-27, 28-32 TPI | 19.90 |
| TBG958 | 33016 | Metric Bolt; .75-1.0, 1.25-1.5, 1.75-2.0, 2.5-3.0 mm | 21.10 |
| QG251 | 33024 | Set of 4: 1 each of above and a #7 file, in pouch | 83.60 |

ASSORTED MINIATURE FILES

- Length: 5 1/2"
- Selection of 6 miniature files with fine cut for intricate work
- 1 each of equaling, half round, flat, round, three square, square files
- Handy vinyl pouch included
- Ideal for handycrafts and hobbies
- Ideal for use on wood, metal and plastic

Model No. TBH175
Mfg. No. 42030
Price/Each \$49.90



Nicholson®

METAL FERRULED WOODEN HANDLES

- Made from close grain hardwood with nickel-plated metal ferrules
- Wax finish

Nicholson®



SELECTION CHART

| Item | Size - | 4" | 5" | 6" | 7" | 8" | 9" | 10" |
|---------|--------|----|----|----|----|----|----|-----|
| Taper | | 4 | 3 | 3 | 3 | 2 | 1 | 1 |
| Slim | | 4 | 4 | 4 | 4 | 3 | - | 2 |
| X Slim | | 4 | 4 | 4 | 4 | 4 | - | - |
| XX Slim | | - | 4 | 4 | 4 | 4 | - | - |

| Item | Size - | 8 x 3/16" | 8 x 7/32" | 8 x 1/4" | 8 x 5/16" | 8 x 3/8" |
|----------|--------|-----------|-----------|----------|-----------|----------|
| Chainsaw | | 4 | 4 | 4 | 4 | 3 |

| Item | Size - | 4" | 6" | 8" | 10" | 12" | 14" |
|-------------------|--------|----|----|----|-----|-----|-----|
| Mill | | 3 | 2 | 2 | 0 | 0 | 00 |
| Flat | | 3 | 2 | 2 | 0 | 0 | 00 |
| Hand | | 3 | 2 | 1 | 1 | 0 | - |
| Half Round | | 4 | 3 | 2 | 1 | 00 | 000 |
| Warding | | 3 | 3 | 2 | 1 | - | - |
| Knife | | 3 | 2 | 2 | 1 | 0 | - |
| Round | | 4 | 4 | 3 | 3 | 1 | 0 |
| Square | | 4 | 4 | 3 | 2 | 1 | 0 |
| Cantsaw | | - | 3 | 2 | 1 | - | - |
| Crosscut | | - | - | 1 | 0 | - | - |
| Tanged Horse Rasp | | - | - | - | - | 000 | 000 |
| Platers Special | | - | - | - | - | - | 000 |

| Model No. | Mfg. No. | Handle No. | Size" | Price/Each |
|-----------|----------|------------|----------------|------------|
| TBG897 | 21470N | 000 | 5 3/4 x 1 5/8 | 5.34 |
| VS786 | 21471N | 00 | 5 3/4 x 1 5/8 | 5.34 |
| VS788 | 21485N | 1 | 4 7/8 x 1 5/16 | 3.32 |
| TBG902* | 21526N | 1 | 4 7/8 x 1 5/16 | 3.35 |
| VS789 | 21494N | 2 | 4 1/2 x 1 3/16 | 2.99 |
| TBG901* | 21524N | 2 | 4 1/2 x 1 3/16 | 2.94 |
| VS790 | 21503N | 3 | 4 1/8 x 1 1/16 | 2.84 |
| TBG900* | 21522N | 3 | 4 1/8 x 1 1/16 | 2.92 |
| VS791 | 21511N | 4 | 3 3/4 x 1 5/16 | 2.51 |
| TBG899* | 21520N | 4 | 3 3/4 x 1 5/16 | 2.54 |

*Carded

FILE CLEANERS

- Available in two styles – file card for general cleaning of file teeth and file card/brush especially for use on finer cut files



Nicholson®

| Model No. | Mfg. No. | Length" | Description | Price /Each |
|-----------|----------|---------|---------------------|-------------|
| QG064 | 21458 | 10 | File Card | 16.70 |
| YA162 | 21467 | 10 | File Card and Brush | 23.60 |

HOOK & PICK SETS

- 5" aluminum handle, knurled for a sure grip
- Four heat-treated, high carbon steel picks: "O"-ring pick, 90°, straight and hook
- Pick are used to pull "O"-rings, seals, cotter pins, and brushes more quickly and easily

Model No. TGZ798
Mfg. No. 3121
Price/Each \$14.40





NOGA BURRS

LIZA BURR

- Designed for use with either fine blades, or heavy-duty deburring blades
- Telescoping arm for blades
- Fine blades reach from 20 to 94 mm
- Heavy-duty blades reach from 20 to 110 mm
- Blades can be stored in the universal handle

Model No. QF794
Mfg. No. LB1000
Price/Each \$33.70



RAPID BURR

- Will accept all "S" (E) series blades which are replaced by pulling sleeve back into handle and taking blade out

Model No. QC778
Mfg. No. RB1000
Price/Each \$19.50



NOGA BURR 3

- Will do almost all of your deburring jobs
- Includes: NG-1 handle, S10, S20 and S35 blades

Model No. QG273
Mfg. No. NG1003
Price/Each \$29.70



SUPER BURR

- Includes: NG-3 handle, S holder, S100, S20 and S30 blades

Model No. BB532
Mfg. No. NG3003
Price/Each \$43.70



TELE BURR

- Includes: NG-3 handle, N holder (telescopes from 25 mm to 115 mm), N1 and N2 blades

Model No. TLV236
Mfg. No. NG3002
Price/Each \$33.60



ROTO DRIVE

- The quickest way to chamfer by hand
- Single flute countersink provides a smoother cut
- Includes: NG-1 handle and RD10.4 RotoDrive countersink

Model No. TLV239
Mfg. No. NG1200
Price/Each \$65.30



CONVEXED CERA-CUT

- Ideal for all plastic materials and soft metals
- Ideal for surface scraping and parting line deflashing
- Blade can be replaced
- Includes: Cera-Cut handle and 250 mm convexed radius blade

Model No. TLV238
Mfg. No. CR2000
Price/Each \$81.20



BRONZE UNIKIT



- Most economical deburring kit for all machinists
- Includes: Noga Grip 3 handle, N holder, S holder, C holder and C20

Model No. TLV250
Mfg. No. NG9200
Price/Each \$176.00

LIGHT-DUTY DEBURRING BLADES



| Model No. | Description | Applications | Price /Each |
|-----------|-------------------|--|-------------|
| QH871 | Blades N1 | Steel, Aluminum, Plastic | 27.70 |
| TLV240 | Blades N1 Tin | Abrasive Material | 55.89 |
| QC788 | Blades N2 | Brass and Cast Iron | 28.10 |
| TLV241 | Blades N2 Tin | Stainless Steel | 75.40 |
| TLV242 | Blades N10 Cobalt | Plastic and Hard Materials | 43.60 |
| TLV243 | Blades N3 | Interior and Exterior Burrs | 55.90 |
| TLV244 | Blades N6 | Cross Holes in Difficult to Reach Places | 83.90 |

HEAVY-DUTY DEBURRING BLADES



| Model No. | Description | Applications | Price /Each |
|-----------|--------------------|--|-------------|
| QF501 | Blades S10 | Steel, Aluminum, Plastic | 34.90 |
| TLV245 | Blades S10 Tin | Abrasive Material | 58.10 |
| QF903 | Blades S20 | Brass and Cast Iron | 39.40 |
| TLV247 | Blades S20 Tin | Stainless Steel | 99.90 |
| QF332 | Blades S30 | Interior and Exterior Burrs | 39.90 |
| QF903 | Blades S35 | Straight Edges on Most Material | 39.40 |
| TLV248 | Blades S60 | Cross Holes in Difficult to Reach Places | 83.90 |
| BB413 | Blades S100 Cobalt | Plastic and Hard Materials | 47.20 |
| QH870 | Blades S101 | Fine Edges on All Materials | 43.20 |
| TLV249 | Blades S150 | Holes as Small as 1.5 mm Dia. | 41.80 |
| BB376 | Blades S202 | Brass and Cast Iron Fine Edges | 41.50 |

238-PC. MASTER TOOL SETS WITH STEEL CHEST & CART

Model No. TLV423
Price/Each \$2240.00

SET INCLUDES:

| Model No. | Description | Model No. | Description |
|-----------|---|-----------|---|
| TBP314 | ATB300 Tool Chest, 6 Drawer, 26" x 18" x 19" | TJZ097 | Locking plier, C-Clamps w/ Swivel Pads, 11" L |
| TBP315 | ATB300 Tool cart, 7 Drawer, 27" x 18" x 35 1/2" | TJZ100 | Wrench, Adjustable, 6", w/ Composite grip |
| TJZ057 | Screwdriver, Slot cabinet, 1/8" Tip, 3" Shank | TJZ101 | Wrench, Adjustable, 8", w/ Composite grip |
| TJZ058 | Screwdriver, Slot cabinet, 3/16" Tip, 4" Shank | TJZ102 | Wrench, Adjustable, 10", w/ Composite grip |
| TJZ059 | Screwdriver, Slot cabinet, 3/16" Tip, 6" Shank | TJZ103 | Wrench, Adjustable, 12", w/ Composite grip |
| TJZ060 | Screwdriver, Slot mechanics, 1/4" Tip, 1 1/2 Stubby shank | TJZ104 | Wrench, Adjustable, 15" |
| TJZ061 | Screwdriver, Slot mechanics, 1/4" Tip, 4" Shank | TJZ105 | Wrench, Adjustable, 18" |
| TJZ062 | Screwdriver, Slot mechanics, 1/4" Tip, 5" Shank | TJZ108 | Wrench, Straight pipe, 12", 2" Pipe capacity |
| TJZ063 | Screwdriver, Slot mechanics, 1/4" Tip, 6" Shank | TLV055 | Aurora 14-Pc. S.A.E. Wrench set with pouch |
| TJZ064 | Screwdriver, Slot mechanics, 5/16" Tip, 6" Shank | TLV056 | Aurora 14-Pc. Metric Wrench set with pouch |
| TJZ065 | Screwdriver, Slot mechanics, 3/8" Tip, 8" Shank | TLV356 | Socket set, 22-Pc., 1/4" Drive S.A.E. |
| TJZ066 | Screwdriver, Phillips, #0 Tip, 2 1/2" Shank | TLV357 | Socket set, 20-Pc., 3/8" Drive S.A.E. |
| TJZ067 | Screwdriver, Phillips, #1 Tip, 3 1/4" Shank | TLV358 | Socket set, 24-Pc., 3/8" Drive Metric |
| TJZ068 | Screwdriver, Phillips, #2 Tip, 4" Shank | TLV359 | Socket Set, 29-Pc., 1/2" Drive S.A.E./Metric |
| TJZ069 | Screwdriver, Phillips, #2 Tip, 1 1/2" Stubby shank | TLZ420 | Cold chisel set, 6-Pc. |
| TJZ070 | Screwdriver, Phillips, #3 Tip, 6" Shank | TLZ421 | Pin punch set, 7-Pc. |
| TJZ071 | Screwdriver, Square, #0 Tip, 4" Shank | TLZ422 | Draft Punch set, 7-Pc. |
| TJZ072 | Screwdriver, Square, #1 Tip, 4" Shank | TLZ423 | Centre punch set, 5-Pc. |
| TJZ073 | Screwdriver, Square, #2 Tip, 6" Shank | TJZ030 | Hacksaw frame, Standard, Adjustable 10" to 12" |
| TJZ074 | Screwdriver, Square, #3 Tip, 6" Shank | TJZ047 | Action bar, 1 3/8" x 1/4" x 13 1/2" |
| TJZ075 | Screwdriver, Square, #1 Tip, 1 1/2" Stubby shank | PE812 | Utility knife, H-D, w/ Auto Reload, Snap-off blades |
| TJZ076 | Screwdriver, Square, #2 Tip, 1 1/2" Stubby shank | TJZ033 | Hammer, Hickory handle, 16-oz., Claw |
| TJZ077 | Screwdriver, Square, #3 Tip, 1 1/2" Stubby shank | TJZ034 | Hammer, Hickory handle, 22-oz., Framing |
| TJZ078 | Plier, Slip joint, 6" L | TJZ035 | Hammer, Dead blow, 8-oz. |
| TJZ079 | Plier, Groove joint, 8" L | TJZ036 | Hammer, Dead blow, 16-oz. |
| TJZ080 | Plier, Groove joint, 10" L | TJZ037 | Hammer, Dead blow, 24-oz. |
| TJZ082 | Plier, Diagonal cutting, 5" L | TJZ038 | Hammer, Dead blow, 32-oz. |
| TJZ083 | Plier, Diagonal cutting, 6" L | TJZ039 | Hammer, Ball Peen, 8-oz. |
| TJZ084 | Plier, Diagonal cutting, 7" L | TJZ040 | Hammer, Ball Peen, 16-oz. |
| TJZ085 | Plier, Long nose cutting, 5" L | TJZ041 | Hammer, Ball Peen, 24-oz. |
| TJZ086 | Plier, Long nose cutting, 6" L | TJZ042 | Hammer, Ball Peen, 32-oz. |
| TJZ087 | Plier, Long nose cutting, 8" L | TJZ043 | Mallet, 16-oz., Black |
| TJZ088 | Plier, Linesman cutting, 7" L | TJZ044 | Mallet, 32-oz., Black |
| TJZ089 | Plier, Linesman cutting, 8" L | TJZ052 | Hex keys, S.A.E. Short arm, 13 Keys, 0.050" - 3/8" |
| TJZ090 | Locking plier, Curved jaw w/ wire cutter, 4" L | TJZ053 | Hex keys, Metric Short arm, 9 Keys |
| TJZ091 | Locking plier, Curved jaw w/ wire cutter, 5" L | TJZ801 | Measuring tape, HD, 1" W x 25' L, in/ft, Composite grip |
| TJZ092 | Locking plier, Curved jaw w/ wire cutter, 7" L | TJZ802 | Measuring tape, HD, 1" W x 25' L, in/cm, Composite grip |
| TJZ093 | Locking plier, Curved jaw w/ wire cutter, 10" L | TJZ861 | Digital Caliper, Stainless steel, 8" |
| TJZ094 | Locking plier, Long nose w/ wire cutter 4" L | AD084 | Mini grease gun, Push type, 80CC |
| TJZ095 | Locking plier, Long nose w/ wire cutter, 6" L | | |
| TJZ096 | Locking plier, C-Clamps w/ Swivel Pads, 6" L | | |



17-PC. BASIC TOOL SETS

Model No. TLV075
Price/Each \$147.00

SET INCLUDES:

| Model No. | Description |
|-----------|--------------------------------|
| TJZ062 | 1/4" Slot screwdriver |
| TJZ068 | #2 Phillips screwdriver |
| TJZ073 | #2 Square screwdriver |
| TJZ033 | Hammer, 16-oz. claw |
| TJZ079 | Groove joint pliers |
| TJZ083 | Diagonal cutting pliers |
| TJZ086 | Long nose pliers |
| TJZ092 | Locking pliers |
| TJZ095 | Long nose Locking pliers |
| TJZ117 | Measuring tape |
| TLV083 | Tool box |
| PE549 | Utility knife |
| TJZ102 | Adjustable combo Wrench |
| TJZ060 | 1/4" Stubby Slot screwdriver |
| TJZ069 | #2 Stubby Phillips screwdriver |
| TJZ076 | #2 Stubby Square screwdriver |
| TJZ075 | #1 Stubby Square screwdriver |



TOOL SETS

70-PC. STARTER TOOL SETS WITH STEEL CHEST

Model No. TLV421
Price/Each \$616.00

SET INCLUDES:

| Model No. | Description |
|-----------|--|
| TBP312 | ATB300 Tool Chest, 4 Drawer, 26" x 12" x 14 1/2" |
| TJZ040 | Hammer, Ball Peen, 16-oz. |
| TJZ036 | Hammer, Dead blow, 16-oz. |
| TJZ033 | Hammer, Hickory handle, 16-oz., Claw |
| TJZ078 | Plier, Slip joint, Blacknickel finish, 6" L |
| TJZ079 | Plier, Groove joint, 8" L |
| TJZ084 | Plier, Diagonal cutting, 7" L |
| TJZ086 | Plier, Long nose, Cutting, 6" L |
| TJZ088 | Plier, Linesman cutting, 7" L |
| TJZ092 | Locking plier, Curved jaw w/ wire cutter, 7" L |
| TLZ417 | Centre punch, 5/32" x 5" L |
| TLZ418 | Centre punch, 1/4" x 6" L |
| TLZ403 | Pin punch 1/8" x 4 3/4" L |
| TLZ405 | Pin punch 3/16" x 5 1/4" L |
| TLZ397 | Cold chisel, 3/8" x 5 1/2" L |
| TLZ398 | Cold chisel, 1/2" x 6" L |
| TLZ400 | Cold chisel, 3/4" x 7" L |
| TLZ412 | Drift punch 1/4" x 12" L |
| TJZ072 | Screwdriver, Square, #1 Tip, 4" Shank |
| TJZ073 | Screwdriver, Square, #2 Tip, 6" Shank |
| TJZ067 | Screwdriver, Phillips, #1 Tip, 3 1/4" Shank |
| TJZ068 | Screwdriver, Phillips, #2 Tip, 4" Shank |
| TJZ057 | Screwdriver, Slot cabinet, 1/8" Tip, 3" Shank |
| TJZ061 | Screwdriver, Slot mechanics, 1/4" Tip, 4" Shank |
| TJZ064 | Screwdriver, Slot mechanics, 5/16" Tip, 6" Shank |
| TJZ101 | Wrench, Adjustable, 8", Composite grip |
| TJZ103 | Wrench, Adjustable, 12", Composite grip |
| TJZ054 | Hex keys, S.A.E., Composite grip fold-up, 9 Keys |
| TLV055 | Aurora 14-Pc. S.A.E. Wrench Set with pouch |
| TLV357 | Socket set, 20-Pc., 3/8" Drive S.A.E. |

aurora tools

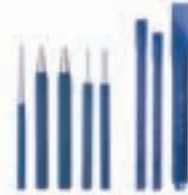

118-PC. PROFESSIONAL TOOL SETS

Model No. TLZ460
Price/Each \$596.00

aurora tools

SET INCLUDES:

| Model No. | Description |
|-----------|--------------------------------|
| PE344 | Utility knife |
| TJZ030 | Hacksaw |
| TJZ033 | Hammer |
| TJZ041 | Pein Hammer |
| TJZ047 | Action bar |
| TJZ078 | Split joint pliers |
| TJZ080 | Groove joint pliers |
| TJZ084 | Diagonal cutting pliers |
| TJZ087 | Long nose pliers |
| TJZ089 | Linesman pliers |
| TJZ093 | Locking pliers |
| TJZ095 | Long nose Locking pliers |
| TJZ102 | Adjustable Wrench |
| TLV086 | Tool box |
| TJZ801 | Measuring tape |
| TJZ817 | S.A.E. combo Wrench set |
| TJZ818 | Metric Wrench set |
| TJZ822 | 20-Pc. S.A.E. socket set |
| TJZ831 | 20-Pc. metric socket set |
| TJZ861 | Caliper |
| TJZ052 | S.A.E. hex key set |
| TJZ053 | Metric hex key set |
| TJZ057 | 1/8" Slot screwdriver |
| TJZ058 | 3/16" Slot screwdriver |
| TJZ060 | 1/4" Stubby Slot screwdriver |
| TJZ061 | 1/4" Slot screwdriver |
| TJZ064 | 5/16" Slot screwdriver |
| TJZ065 | 3/8" Slot screwdriver |
| TJZ066 | #0 Phillips screwdriver |
| TJZ067 | #1 Phillips screwdriver |
| TJZ068 | #2 Phillips screwdriver |
| TJZ069 | #2 Stubby Phillips screwdriver |
| TJZ070 | #3 Phillips screwdriver |
| TJZ071 | #0 Square screwdriver |
| TJZ072 | #1 Square screwdriver |
| TJZ073 | #2 Square screwdriver |
| TJZ074 | #3 Square screwdriver |
| TJZ076 | #2 Stubby Square screwdriver |
| SA0051 | Work gloves |
| SAP877 | Glasses |



86-PC. TRADESMAN TOOL SETS

Model No. TLV076
Price/Each \$415.00

SET INCLUDES:

| Model No. | Description |
|-----------|--------------------------------|
| PE344 | Utility knife |
| TJZ030 | Hacksaw |
| TJZ033 | Hammer, 16-oz. claw |
| TJZ036 | Dead blow Hammer |
| TJZ052 | Hex keys, S.A.E. |
| TJZ053 | Hex keys, metric |
| TJZ078 | Split joint pliers |
| TJZ080 | Groove joint pliers |
| TJZ084 | Diagonal cutting pliers |
| TJZ087 | Long nose pliers |
| TJZ089 | Linesman pliers |
| TJZ093 | Locking pliers |
| TJZ095 | Long nose Locking pliers |
| TJZ102 | Adjustable combo Wrench |
| TJZ801 | Measuring tape |
| TJZ057 | 1/8" Slot screwdriver |
| TJZ058 | 3/16" Slot screwdriver |
| TJZ060 | 1/4" Stubby Slot screwdriver |
| TJZ061 | 1/4" Slot screwdriver |
| TJZ064 | 5/16" Slot screwdriver |
| TJZ065 | 3/8" Slot screwdriver |
| TJZ066 | #0 Phillips screwdriver |
| TJZ067 | #1 Phillips screwdriver |
| TJZ068 | #2 Phillips screwdriver |
| TJZ069 | #2 Stubby Phillips screwdriver |
| TJZ070 | #3 Phillips screwdriver |
| TJZ071 | #0 Square screwdriver |
| TJZ072 | #1 Square screwdriver |
| TJZ073 | #2 Square screwdriver |
| TJZ074 | #3 Square screwdriver |
| TJZ076 | #2 Stubby Square screwdriver |
| TJZ817 | 11-Pc. S.A.E. Wrench set |
| TJZ822 | 20-Pc. 3/8" S.A.E. socket set |
| SA0051 | Gloves |
| SAP877 | Glasses |
| TJZ047 | Action bar |
| TLV086 | Tool box |



40-PC. MAINTENANCE TOOL SETS

Model No. TLZ459
Price/Each \$235.00

SET INCLUDES:

| Model No. | Description |
|-----------|---------------------------|
| PE330 | Utility knife |
| TJZ030 | Hacksaw |
| TJZ033 | Hammer |
| TJZ043 | Rubber mallet |
| TJZ054 | Hex key set |
| TJZ080 | Groove joint pliers |
| TJZ083 | Diagonal cutting pliers |
| TJZ086 | Long nose cutting pliers |
| TJZ092 | Curved jaw Locking pliers |
| TJZ095 | Long nose Locking pliers |
| TJZ102 | Adjustable Wrench |
| TJZ117 | Measuring tape |
| TLV083 | Tool box |
| TJZ057 | 1/8" Slot screwdriver |
| TJZ061 | 1/4" Slot screwdriver |
| TJZ064 | 5/16" Slot screwdriver |
| TJZ067 | #1 Phillips screwdriver |
| TJZ068 | #2 Phillips screwdriver |
| TJZ072 | #1 Square screwdriver |
| TJZ073 | #2 Square screwdriver |
| TJZ817 | S.A.E. combo Wrench set |
| SAN638 | Work gloves |



TOOL SETS

112-PC. INTERMEDIATE TOOL SETS WITH STEEL CHEST

Model No. TLV422
Price/Each \$1025.00

SET INCLUDES:

| Model No. | Description |
|-----------|---|
| TEP315 | ATB300 Tool cart, 7 Drawer, 27" x 18" x 35 1/2" |
| TJZ057 | Screwdriver, Slot cabinet, 1/8" Tip, 3" Shank |
| TJZ058 | Screwdriver, Slot cabinet, 3/16" Tip, 4" Shank |
| TJZ060 | Screwdriver, Slot mechanics, 1/4" Tip, 1 1/2 Stubby shank |
| TJZ061 | Screwdriver, Slot mechanics, 1/4" Tip, 4" Shank |
| TJZ064 | Screwdriver, Slot mechanics, 5/16" Tip, 6" Shank |
| TJZ065 | Screwdriver, Slot mechanics, 3/8" Tip, 8" Shank |
| TJZ066 | Screwdriver, Phillips, #0 Tip, 2 1/2" Shank |
| TJZ067 | Screwdriver, Phillips, #1 Tip, 3 1/4" Shank |
| TJZ068 | Screwdriver, Phillips, #2 Tip, 4" Shank |
| TJZ069 | Screwdriver, Phillips, #2 Tip, 1 1/2" Stubby shank |
| TJZ070 | Screwdriver, Phillips, #3 Tip, 6" Shank |
| TJZ071 | Screwdriver, Square, #0 Tip, 4" Shank |
| TJZ072 | Screwdriver, Square, #1 Tip, 4" Shank |
| TJZ073 | Screwdriver, Square, #2 Tip, 6" Shank |
| TJZ074 | Screwdriver, Square, #3 Tip, 6" Shank |
| TJZ076 | Screwdriver, Square, #2 Tip, 1 1/2" Stubby shank |
| TJZ078 | Plier, Slip joint, 6" L |
| TJZ079 | Plier, Groove joint, 8" L |
| TJZ082 | Plier, Diagonal cutting, 5" L |
| TJZ084 | Plier, Diagonal cutting, 7" L |
| TJZ085 | Plier, Long nose cutting, 5" L |
| TJZ087 | Plier, Long nose cutting, 8" L |
| TJZ089 | Plier, Linesman Cutting, 8" L |
| TJZ091 | Locking plier, Curved jaw w/ wire cutter, 5" L |
| TJZ093 | Locking plier, Curved jaw w/ wire cutter, 10" L |
| TJZ095 | Locking plier, Long nose w/ wire cutter, 6" L |
| TJZ097 | Locking plier, C-Clamps w/ Swivel Pads, 11" L |
| TJZ100 | Wrench, Adjustable, 6", w/ Composite grip |
| TJZ103 | Wrench, Adjustable, 12", w/ Composite grip |
| TLV053 | Aurora 11-Pc. S.A.E. Wrench Set with pouch |
| TLV054 | Aurora 11-Pc. Metric Wrench Set with pouch |
| TLV360 | Socket Set, 41-Pc., 1/4" & 3/8" Drive S.A.E./Metric |
| TLZ396 | Cold chisel, 5/16" x 5" L |
| TLZ398 | Cold chisel, 1/2" x 6" L |
| TLZ400 | Cold chisel, 3/4" x 7" L |
| TLZ417 | Centre punch, 5/32" x 5" L |
| TLZ415 | Centre punch, 5/64" x 3 1/2" L |
| TLZ419 | Centre punch, 3/8" x 6 1/4" L |
| TLZ402 | Pin punch 3/32" x 4 1/2" L |
| TLZ405 | Pin punch 3/16" x 5 1/4" L |
| TLZ403 | Pin punch 1/8" x 4 3/4" L |
| TJZ030 | Hacksaw frame, Standard, Adjustable 10" to 12" |
| TJZ047 | Action bar, 1 3/8" x 1/4" x 13 1/2" |
| PE812 | Utility knife, H-D, w/ auto reload, Snap-off blades |
| TJZ033 | Hammer, Hickory handle, 16-oz., Claw |
| TJZ036 | Hammer, Dead blow, 16-oz. |
| TJZ038 | Hammer, Dead blow, 32-oz. |
| TJZ040 | Hammer, Ball Peen, 16-oz. |
| TJZ042 | Hammer, Ball Peen, 32-oz. |
| TJZ052 | Hex keys, S.A.E. Short arm, 13 Keys, 0.050" - 3/8" |
| TJZ801 | Measuring tape, HD, 1" W x 25' L, in/ft, Composite grip |



aurora tools

Can't find what
you're looking for?
Call us today!



41-PC 1/4" & 3/8" DRIVE S.A.E./ METRIC SOCKET SETS

- Chrome vanadium steel for extra strength and durability
- Ratchet with contoured handle for comfort and added torque
- Chrome-plated sockets to resist rust
- 6-point sockets for a snug fit
- Laser-marked socket size on each socket for easy identification

aurora tools®



SET INCLUDES:

- 19 1/4" standard sockets:** 3/16", 7/32", 1/4", 9/32", 5/16", 11/32", 3/8", 7/16", 1/2", 4, 4.5, 5, 6, 7, 8, 9, 10, 11, 12 mm
- 16 3/8" standard sockets:** 3/8", 7/16", 1/2", 9/16", 5/8", 11/16", 3/4", 13/16", 10, 11, 12, 13, 14, 15, 17, 19 mm
- 6 accessories:** Quick release ratchet 3/8" drive
Extensions 3/8" drive: 3" and 6"
Universal joint 3/8" drive
3/8" drive adapter (3/8" F x 1/4" M)
Plastic handle driver 1/4"

Model No. TLV360
Price/Each \$93.95

120-PC 1/4", 3/8" & 1/2" DRIVE S.A.E./ METRIC SOCKET & WRENCH SETS

aurora tools®



SET INCLUDES:

- 20 1/4" standard sockets:** 5/32", 3/16", 7/32", 1/4", 9/32", 5/16", 11/32", 3/8", 7/16", 1/2", 4, 5, 6, 7, 8, 9, 10, 11, 12, 13 mm
- 20 3/8" standard sockets:** 3/8", 7/16", 1/2", 9/16", 5/8", 11/16", 3/4", 13/16", 7/8", 9, 10, 11, 12, 13, 14, 15, 16, 17, 18, 19 mm
- 11 1/2" standard sockets:** 15/16", 1", 1 1/16", 1 1/4", 20, 21, 22, 24, 27, 30, 32 mm
- 4 1/4" deep sockets:** 8, 9, 10, 11 mm
- 4 3/8" deep sockets:** 13, 14, 15, 17 mm
- 8 3/8" Torx sockets:** E8, E10, E11, E12, E14, E16, E18, E20
- 4 1/2" impact sockets:** 17, 19, 21, 24 mm
- 7 1/4" Torx bits:** T10, T15, T20, T25, T27, T30, T40
- 17 3/8" bit sockets:** Torx: T20, T30, T40, T45, T50, T55, T60
Hex: 3, 4, 5, 6mm
Phillips: #1, #2
Slotted: 5.5, 6.5mm
Square: #1, #2
- 23 accessories:** Quick release ratchet 1/4", 3/8" and 1/2"
Spark plug socket 3/8" drive: 16, 21 mm
Universal joint 1/4", 3/8", 1/2"
Extension 1/4" drive: 2"
Extension 3/8" drive: 3" and 6"
Extension 1/2" drive: 5" and 10"
Plastic handle driver 1/4" drive
Bit adapter 1/4" drive
Combination wrench: 8, 9, 10, 11, 12, 13, 14, 17, 18, 19 mm

Model No. TLV361
Price/Each \$244.00

210-PC 1/4", 3/8" & 1/2" DRIVE S.A.E./ METRIC SOCKET & WRENCH SETS

- Chrome vanadium steel for extra strength and durability
- Ratchet with contoured handle for comfort and added torque
- Chrome-plated sockets to resist rust
- 6-point sockets for a snug fit
- Laser-marked socket size on each socket for easy identification

aurora tools®



SET INCLUDES:

- 24 1/4" standard sockets:** 5/32", 3/16", 7/32", 1/4", 9/32", 5/16", 11/32", 3/8", 7/16", 1/2", 9/16", 4, 4.5, 5, 6, 6.5", 7, 8, 9, 10, 11, 12, 13, 14 mm
- 25 3/8" standard sockets:** 1/4", 9/32", 5/16", 11/32", 3/8", 7/16", 1/2", 9/16", 5/8", 11/16", 3/4", 6, 7, 8, 9, 10, 11, 12, 13, 14, 15, 16, 17, 18, 19 mm
- 27 1/2" standard sockets:** 5/16", 3/8", 7/16", 1/2", 9/16", 5/8", 11/16", 3/4", 7/8", 1", 8, 9, 10, 11, 12, 13, 14, 15, 16, 17, 18, 19, 20, 21, 22, 23, 24 mm
- 15 1/4" deep sockets:** 1/4", 5/16", 3/8", 7/16", 1/2", 9/16", 6, 7, 8, 9, 10, 11, 12, 13, 14 mm
- 20 3/8" deep sockets:** 5/16", 3/8", 7/16", 1/2", 9/16", 5/8", 11/16", 3/4", 8, 9, 10, 11, 12, 13, 14, 15, 16, 17, 18, 19 mm
- 21 1/2" deep sockets:** 5/16", 3/8", 7/16", 1/2", 5/8", 9/16", 11/16", 3/4", 13/16", 7/8", 10, 11, 12, 13, 14, 16, 17, 19, 20, 21, 22 mm
- 30 1/4" shank bits:** Phillips: #0, 1, 2, 3
Slotted: 3, 4, 5, 6, 7, 8 mm
Pozi driv: #0, 1, 2, 3
Hex: 2, 3, 4, 5, 6, 8 mm
Torx: T8, T10, T15, T20, T25, T27, T30
Square: #1, 2, 3
- 12 8 mm shank bits:** Phillips: #3, 4
Pozi driv: #3, 4
Hex: 8, 10, 12, 14 mm
Torx: T40, T45, T50, T55
- 36 accessories:** Quick release ratchet 1/4", 3/8" and 1/2"
Spark plug socket 1/2" drive: 16, 21 mm
Universal joint 1/4", 3/8", 1/2"
Extension 1/4" drive: 2", 4"
Extension 3/8" drive: 3" and 6"
Extension 1/2" drive: 5" and 10"
Plastic handle driver 1/4" drive
Sliding T-bar: 1/4" and 3/8"
3-Way adapter (3/8" F x 1/2" M)
Bit adapter 1/4" drive
Bit adapter 1/2" drive
Combination wrench: 8, 10, 11, 13, 14, 16, 18, 19 mm
5/16", 3/8", 7/16", 1/2", 9/16", 5/8", 11/16", 3/4"

Model No. TLV362
Price/Each \$399.00

SOCKET SETS

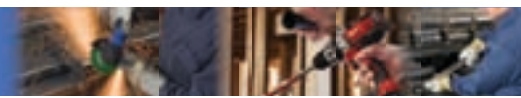

SOCKET SETS

- Chrome vanadium steel for extra strength and durability
- Ratchet with contoured handle for comfort and added torque
- Chrome-plated sockets to resist rust
- 6-point sockets for a snug fit
- Laser-marked socket size on each socket for easy identification

aurora tools®

22-PC 1/4" DRIVE S.A.E. SOCKET SETS

SET INCLUDES:

9 standard sockets: 3/16", 7/32", 1/4", 9/32", 5/16", 11/32", 3/8", 7/16", 1/2"

7 deep sockets: 1/4", 9/32", 5/16", 11/32", 3/8", 7/16", 1/2"

6 accessories: Quick release ratchet
Extensions: 2" and 6"
Universal joint
Drive palm ratchet
Plastic handle driver

Model No. TLV356
Price/Each \$56.30



20-PC 3/8" DRIVE S.A.E. SOCKET SETS

SET INCLUDES:

9 standard sockets: 3/8", 7/16", 1/2", 9/16", 5/8", 11/16", 3/4", 13/16", 7/8"

8 deep sockets: 3/8", 7/16", 1/2", 9/16", 5/8", 11/16", 3/4", 13/16"

3 accessories: Quick release ratchet
Extensions: 2" and 3"

Model No. TLV357
Price/Each \$62.90



24-PC 3/8" DRIVE METRIC SOCKET SETS

SET INCLUDES:

13 standard sockets: 7, 8, 9, 10, 11, 12, 13, 14, 15, 16, 17, 18, 19 mm

8 deep sockets: 10, 11, 12, 13, 14, 15, 17, 19 mm

3 accessories: Spark plug socket 16 mm
Ratchet
3" extension

Model No. TLV358
Price/Each \$59.95



29-PC 1/2" DRIVE S.A.E./METRIC SOCKET SETS

SET INCLUDES:

24 standard sockets: 3/8", 7/16", 1/2", 9/16", 5/8", 11/16", 3/4", 13/16", 7/8", 15/16", 1" 9, 10, 11, 12, 13, 14, 15, 16, 17, 18, 19, 20, 21 mm

5 accessories: Quick release ratchet
Extensions: 5" and 10"
Universal joint
3/8" drive adapter
(3/8" F x 1/2" M)

Model No. TLV359
Price/Each \$108.00



3/8" DRIVE METRIC SOCKET SETS

- Includes plastic case

Model No. TI997

Price/Each \$384.00



ARMSTRONG
INDUSTRIAL HAND TOOLS

SET INCLUDES:

| Model No. | Mfg. No. | Size mm |
|---------------------------------|----------|---------|
| 12-POINT STANDARD LENGTH | | |
| TI937 | 38-108 | 8 |
| TI938 | 38-109 | 9 |
| TI939 | 38-110 | 10 |
| TI940 | 38-111 | 11 |
| TI941 | 38-112 | 12 |
| TI942 | 38-113 | 13 |
| TI943 | 38-114 | 14 |
| TI944 | 38-115 | 15 |
| TI945 | 38-116 | 16 |
| TI946 | 38-117 | 17 |
| TI947 | 38-118 | 18 |
| TI948 | 38-119 | 19 |

| Model No. | Mfg. No. | Size mm |
|-----------------------------|----------|---------|
| 12-POINT DEEP LENGTH | | |
| TI949 | 38-308 | 8 |
| TI950 | 38-309 | 9 |
| TI951 | 38-310 | 10 |
| TI952 | 38-311 | 11 |
| TI953 | 38-312 | 12 |
| TI954 | 38-313 | 13 |
| TI955 | 38-314 | 14 |
| TI956 | 38-315 | 15 |
| TI957 | 38-316 | 16 |
| TI958 | 38-317 | 17 |
| TI959 | 38-318 | 18 |
| TI960 | 38-319 | 19 |

DRIVE TOOLS

| Model No. | Mfg. No. | Description |
|-----------|----------|-----------------|
| TI961 | 11-918 | Hinge handle |
| TI962 | 11-922 | Extension 3" |
| TI963 | 11-923 | Extension 6" |
| TI965 | 11-947 | Universal joint |
| TI966 | 11-972 | Ratchet 7 1/2" |

3/8" DRIVE S.A.E. SOCKET SETS

- Includes plastic case

Model No. WJ151

Price/Each \$585.00



ARMSTRONG
INDUSTRIAL HAND TOOLS

SET INCLUDES:

| Model No. | Mfg. No. | Size " |
|---------------------------------|----------|--------|
| 12-POINT STANDARD LENGTH | | |
| TI969 | 11-112 | 3/8 |
| TI970 | 11-114 | 7/16 |
| TI971 | 11-116 | 1/2 |
| TI972 | 11-118 | 9/16 |
| TI973 | 11-120 | 5/8 |
| TI974 | 11-122 | 11/16 |
| TI975 | 11-124 | 3/4 |
| TI976 | 11-126 | 13/16 |
| TI977 | 11-128 | 7/8 |
| 8-POINT SOCKETS | | |
| UM143 | 11-408 | 1/4 |
| UM145 | 11-410 | 5/16 |
| UM146 | 11-412 | 3/8 |

| Model No. | Mfg. No. | Size " |
|------------------------------|----------|--------|
| 12-POINT DEEP LENGTH | | |
| TI978 | 11-312 | 3/8 |
| TI979 | 11-314 | 7/16 |
| TI980 | 11-316 | 1/2 |
| TI981 | 11-318 | 9/16 |
| TI982 | 11-320 | 5/8 |
| TI983 | 11-322 | 11/16 |
| TI984 | 11-324 | 3/4 |
| TI985 | 11-326 | 13/16 |
| TI986 | 11-328 | 7/8 |
| 12-POINT FLEX SOCKETS | | |
| TI988 | 11-514 | 7/16 |
| TI989 | 11-516 | 1/2 |
| TI990 | 11-518 | 9/16 |
| TI991 | 11-520 | 5/8 |
| TI993 | 11-524 | 3/4 |

DRIVE TOOLS

| Model No. | Mfg. No. | Description |
|-----------|----------|---------------|
| TI961 | 11-918 | Hinge handle |
| TI962 | 11-922 | Extension 3" |
| TI963 | 11-923 | Extension 6" |
| TI964 | 11-927 | Extension 12" |

| Model No. | Mfg. No. | Description |
|-----------|----------|-----------------|
| TI965 | 11-947 | Universal joint |
| TI996 | 11-935 | Speed Handle |
| TI966 | 11-972 | Ratchet 7 1/2" |

3/8" DRIVE S.A.E. HEX BIT SETS

- Standard length
- Includes socket bar and clips

Model No. VE003
Price/Each \$96.50

| Model No. | Mfg. No. | Size" |
|-----------|----------|-------|
| VE012 | 11-708 | 1/8 |
| VE013 | 11-710 | 5/32 |
| VE014 | 11-711 | 3/16 |
| VE015 | 11-712 | 7/32 |
| VE016 | 11-713 | 1/4 |
| VE017 | 11-714 | 5/16 |
| VE018 | 11-715 | 3/8 |



ARMSTRONG
INDUSTRIAL HAND TOOLS

1/2" DRIVE METRIC HEX BIT SETS

- Standard length
- Includes socket bar and clips

Model No. VE004
Price/Each \$122.00

| Model No. | Mfg. No. | Size mm |
|-----------|----------|---------|
| VE019 | 39-711 | 6 |
| VE020 | 39-713 | 8 |
| VE021 | 39-715 | 10 |
| VE022 | 39-717 | 12 |
| VE023 | 39-719 | 14 |
| VE024 | 39-722 | 17 |



ARMSTRONG
INDUSTRIAL HAND TOOLS

1/2" DRIVE S.A.E. HEX BIT SETS

- Standard length
- Includes socket bar and clips

Model No. VE005
Price/Each \$145.00

| Model No. | Mfg. No. | Size" |
|-----------|----------|-------|
| VE025 | 12-713 | 1/4 |
| VE026 | 12-714 | 5/16 |
| VE027 | 12-715 | 3/8 |
| VE028 | 12-716 | 7/16 |
| VE029 | 12-717 | 1/2 |
| VE030 | 12-718 | 9/16 |
| VE031 | 12-719 | 5/8 |



ARMSTRONG
INDUSTRIAL HAND TOOLS

1/2" DRIVE METRIC SOCKET SETS

- Includes plastic case
- Model No. TDR171
Price/Each \$599.00



ARMSTRONG
INDUSTRIAL HAND TOOLS

SET INCLUDES:

12-POINT STANDARD LENGTH

| Model No. | Mfg. No. | Size mm |
|-----------|----------|---------|
| TI448 | 39-110 | 10 |
| TI449 | 39-111 | 11 |
| TI450 | 39-112 | 12 |
| TI451 | 39-113 | 13 |
| TI452 | 39-114 | 14 |
| TI453 | 39-115 | 15 |
| TI454 | 39-116 | 16 |
| TI455 | 39-117 | 17 |
| TI456 | 39-118 | 18 |
| TI457 | 39-119 | 19 |
| TI458 | 39-120 | 20 |

| Model No. | Mfg. No. | Size mm |
|-----------|----------|---------|
| TI459 | 39-121 | 21 |
| TI460 | 39-122 | 22 |
| TI461 | 39-123 | 23 |
| TI462 | 39-124 | 24 |
| TI463 | 39-125 | 25 |
| TI464 | 39-126 | 26 |
| TI465 | 39-127 | 27 |
| TI466 | 39-128 | 28 |
| TI467 | 39-129 | 29 |
| TI468 | 39-120 | 30 |
| TI469 | 39-132 | 32 |
| TI470 | 39-136 | 36 |

DRIVE TOOLS

| Model No. | Mfg. No. | Description |
|-----------|----------|-----------------|
| TI935 | 12-918 | Hinge handle |
| TI543 | 12-921 | Extension 2" |
| TI544 | 12-923 | Extension 5" |
| TI545 | 12-924 | Extension 10" |
| TI549 | 12-947 | Universal joint |
| TI550 | 12-972 | Ratchet 10 1/2" |

1/2" DRIVE S.A.E. SOCKET SETS

- Includes plastic case
- Model No. WJ154
Price/Each \$646.00



ARMSTRONG
INDUSTRIAL HAND TOOLS

SET INCLUDES:

| Model No. | Mfg. No. | Size" |
|--------------------------|----------|--------|
| 12-POINT STANDARD LENGTH | | |
| TI403 | 12-112 | 3/8 |
| TI404 | 12-114 | 7/16 |
| TI405 | 12-116 | 1/2 |
| TI406 | 12-118 | 9/16 |
| TI408 | 12-120 | 5/8 |
| TI410 | 12-122 | 11/16 |
| TI411 | 12-124 | 3/4 |
| TI413 | 12-126 | 13/16 |
| TI414 | 12-128 | 7/8 |
| TI415 | 12-130 | 15/16 |
| TI416 | 12-132 | 1 |
| TI417 | 12-134 | 1 1/16 |
| TI418 | 12-136 | 1 1/8 |
| TI420 | 12-140 | 1 1/4 |

| Model No. | Mfg. No. | Size" |
|----------------------|----------|--------|
| 12-POINT DEEP LENGTH | | |
| TI492 | 12-316 | 1/2 |
| TI493 | 12-318 | 9/16 |
| TI494 | 12-320 | 5/8 |
| TI495 | 12-322 | 11/16 |
| TI496 | 12-324 | 3/4 |
| TI497 | 12-326 | 13/16 |
| TI498 | 12-328 | 7/8 |
| TI499 | 12-330 | 15/16 |
| TI500 | 12-332 | 1 |
| TI501 | 12-334 | 1 1/16 |
| TI502 | 12-336 | 1 1/8 |
| TI504 | 12-340 | 1 1/4 |

DRIVE TOOLS

| Model No. | Mfg. No. | Description |
|-----------|----------|-----------------|
| TI935 | 12-918 | Hinge handle |
| TI544 | 12-923 | Extension 5" |
| TI545 | 12-924 | Extension 10" |
| TI550 | 12-972 | Ratchet 10 1/2" |

Ask us about volume prices!



In many cases you will benefit from quantity prices.

SOCKET & ACCESSORIES



1/4" DRIVE RATCHETS

Model No. UM106 5 9/32" L
Mfg. No. 10-972
Price/Each \$39.50



1/4" DRIVE HINGE HANDLES

Model No. UM090 5 3/4" L
Mfg. No. 10-918
Price/Each \$37.20



1/4" DRIVE PLASTIC HANDLE DRIVERS

Model No. UM100 6" L
Mfg. No. 10-943
Price/Each \$16.30



ARMSTRONG
INDUSTRIAL HAND TOOLS

EXTENSIONS



| Model No. | Mfg. No. | Overall Length" | Price /Each |
|-----------|----------|-----------------|-------------|
| UM091 | 10-921 | 2 | 8.98 |
| UM092 | 10-922 | 4 | 12.20 |
| UM093 | 10-923 | 6 | 12.80 |
| UM094 | 10-924 | 10 | 18.30 |
| UM095 | 10-925 | 14 | 20.70 |

SPEEDERS



| Model No. | Mfg. No. | Overall Length" | Price /Each |
|-----------|----------|-----------------|-------------|
| UM098 | 10-935 | 15 3/4 | 35.80 |

1/4" DRIVE ACCESSORIES

6-POINT S.A.E. STANDARD LENGTH SOCKETS



| Model No. | Mfg. No. | Hex Size" | Overall Length" | Price /Each |
|-----------|----------|-----------|-----------------|-------------|
| UM001 | 10-004 | 1/8 | 0.82 | 6.83 |
| UM002 | 10-005 | 5/32 | 0.82 | 6.83 |
| UM003 | 10-006 | 3/16 | 0.82 | 6.83 |
| UM004 | 10-007 | 7/32 | 0.82 | 6.83 |
| UM005 | 10-008 | 1/4 | 0.82 | 6.89 |
| UM006 | 10-009 | 9/32 | 0.82 | 6.92 |
| UM007 | 10-010 | 5/16 | 0.82 | 6.94 |
| UM008 | 10-011 | 11/32 | 0.82 | 6.99 |
| UM009 | 10-012 | 3/8 | 0.82 | 7.15 |
| UM010 | 10-014 | 7/16 | 0.82 | 7.15 |
| UM011 | 10-016 | 1/2 | 0.82 | 7.22 |
| UM012 | 10-018 | 9/16 | 0.82 | 7.29 |

6-POINT S.A.E. DEEP LENGTH SOCKETS



| Model No. | Mfg. No. | Hex Size" | Overall Length" | Price /Each |
|-----------|----------|-----------|-----------------|-------------|
| UM023 | 10-204 | 1/8 | 1.94 | 9.98 |
| UM024 | 10-205 | 5/32 | 1.94 | 9.95 |
| UM025 | 10-206 | 3/16 | 1.94 | 9.95 |
| UM026 | 10-207 | 7/32 | 1.94 | 9.95 |
| UM027 | 10-208 | 1/4 | 1.94 | 9.95 |
| UM028 | 10-209 | 9/32 | 1.94 | 10.50 |
| UM029 | 10-210 | 5/16 | 1.94 | 10.70 |
| UM030 | 10-211 | 11/32 | 1.94 | 10.80 |
| UM031 | 10-212 | 3/8 | 1.94 | 10.80 |
| UM032 | 10-214 | 7/16 | 1.94 | 10.90 |
| UM033 | 10-216 | 1/2 | 1.94 | 10.90 |
| UM034 | 10-218 | 9/16 | 1.94 | 11.20 |

12-POINT S.A.E. STANDARD LENGTH SOCKETS



| Model No. | Mfg. No. | Hex Size" | Overall Length" | Price /Each |
|-----------|----------|-----------|-----------------|-------------|
| UM013 | 10-106 | 3/16 | 0.82 | 7.22 |
| UM014 | 10-107 | 7/32 | 0.82 | 7.22 |
| UM015 | 10-108 | 1/4 | 0.82 | 7.29 |
| UM016 | 10-109 | 9/32 | 0.82 | 7.41 |
| UM017 | 10-110 | 5/16 | 0.82 | 7.39 |
| UM018 | 10-111 | 11/32 | 0.82 | 7.46 |
| UM019 | 10-112 | 3/8 | 0.82 | 7.57 |
| UM020 | 10-114 | 7/16 | 0.82 | 7.69 |
| UM021 | 10-116 | 1/2 | 0.82 | 7.66 |
| UM022 | 10-118 | 9/16 | 0.82 | 7.78 |

12-POINT S.A.E. DEEP LENGTH SOCKETS



| Model No. | Mfg. No. | Hex Size" | Overall Length" | Price /Each |
|-----------|----------|-----------|-----------------|-------------|
| UM035 | 10-306 | 3/16 | 1.94 | 10.80 |
| UM036 | 10-307 | 7/32 | 1.94 | 10.90 |
| UM037 | 10-308 | 1/4 | 1.94 | 10.80 |
| UM038 | 10-309 | 9/32 | 1.94 | 11.20 |
| UM039 | 10-310 | 5/16 | 1.94 | 11.10 |
| UM040 | 10-311 | 11/32 | 1.94 | 11.20 |
| UM041 | 10-312 | 3/8 | 1.94 | 11.20 |
| UM042 | 10-314 | 7/16 | 1.94 | 11.40 |
| UM043 | 10-316 | 1/2 | 1.94 | 11.40 |
| UM044 | 10-318 | 9/16 | 1.94 | 11.70 |

6-POINT METRIC STANDARD LENGTH SOCKETS



| Model No. | Mfg. No. | Hex Size mm | Overall Length mm | Price /Each |
|-----------|----------|-------------|-------------------|-------------|
| UN551 | 37-004 | 4 | 21.3 | 7.34 |
| UN563 | 37-081 | 4.5 | 21.3 | 7.34 |
| UN552 | 37-005 | 5 | 21.3 | 7.39 |
| UN564 | 37-083 | 5.5 | 21.3 | 7.39 |
| UN553 | 37-006 | 6 | 21.3 | 7.53 |
| UN554 | 37-007 | 7 | 21.3 | 7.73 |
| UN555 | 37-008 | 8 | 21.3 | 7.62 |
| UN556 | 37-009 | 9 | 21.3 | 7.69 |
| UN557 | 37-010 | 10 | 21.3 | 7.73 |
| UN558 | 37-011 | 11 | 21.3 | 7.81 |
| UN559 | 37-012 | 12 | 21.3 | 7.89 |
| UN560 | 37-013 | 13 | 21.3 | 7.94 |
| UN561 | 37-014 | 14 | 21.3 | 7.98 |
| UN562 | 37-015 | 15 | 27.0 | 7.99 |

6-POINT METRIC DEEP LENGTH SOCKETS



| Model No. | Mfg. No. | Hex Size mm | Overall Length mm | Price /Each |
|-----------|----------|-------------|-------------------|-------------|
| UN565 | 37-204 | 4 | 49.3 | 11.30 |
| UN577 | 37-281 | 4.5 | 49.5 | 11.30 |
| UN566 | 37-205 | 5 | 49.3 | 11.40 |
| UN578 | 37-283 | 5.5 | 49.5 | 11.40 |
| UN567 | 37-206 | 6 | 49.3 | 11.50 |
| UN568 | 37-207 | 7 | 49.3 | 11.60 |
| UN569 | 37-208 | 8 | 49.3 | 11.90 |
| UN570 | 37-209 | 9 | 49.3 | 11.80 |
| UN571 | 37-210 | 10 | 49.3 | 11.60 |
| UN572 | 37-211 | 11 | 49.3 | 11.70 |
| UN573 | 37-212 | 12 | 49.3 | 11.90 |
| UN574 | 37-213 | 13 | 49.3 | 11.80 |
| UN575 | 37-214 | 14 | 49.3 | 12.20 |
| UN576 | 37-215 | 15 | 49.3 | 12.20 |

UNIVERSAL JOINTS



| Model No. | Mfg. No. | Price /Each |
|-----------|----------|-------------|
| UM102 | 10-947 | 26.20 |

ADAPTORS



| Model No. | Mfg. No. | Size" | Price /Each |
|-----------|----------|---------------|-------------|
| UM103 | 10-952 | 1/4 F x 3/8 M | 9.34 |

S.A.E. STANDARD LENGTH HEX DRIVER SOCKETS



| Model No. | Mfg. No. | Hex Size" | Overall Length" | Price /Each |
|-----------|----------|-----------|-----------------|-------------|
| UM049 | 10-703 | 0.050 | 1.75 | 12.30 |
| UM050 | 10-704 | 1/16 | 1.75 | 12.30 |
| UM052 | 10-706 | 3/32 | 1.75 | 12.30 |
| UM053 | 10-707 | 7/64 | 1.75 | 12.30 |
| UM054 | 10-708 | 1/8 | 1.88 | 12.30 |
| UM055 | 10-709 | 9/64 | 1.88 | 12.30 |
| UM056 | 10-710 | 5/32 | 1.88 | 12.50 |
| UM057 | 10-711 | 3/16 | 1.88 | 12.20 |
| UM058 | 10-712 | 7/32 | 1.88 | 12.60 |
| UM059 | 10-713 | 1/4 | 1.88 | 12.30 |
| UM060 | 10-714 | 5/16 | 1.88 | 12.60 |

METRIC STANDARD LENGTH HEX DRIVER SOCKETS



| Model No. | Mfg. No. | Hex Size mm | Overall Length mm | Price /Each |
|-----------|----------|-------------|-------------------|-------------|
| UN579 | 37-703 | 2 | 46.0 | 12.20 |
| UN580 | 37-704 | 2.5 | 46.0 | 12.30 |
| UN581 | 37-705 | 3 | 47.6 | 12.30 |
| UN582 | 37-707 | 4 | 47.6 | 12.20 |
| UN583 | 37-709 | 5 | 47.6 | 12.30 |
| UN584 | 37-711 | 6 | 47.6 | 12.90 |
| UN585 | 37-713 | 8 | 47.6 | 13.90 |

aurora tools[®]

1/4" DRIVE RATCHETS

Model No. TYL032 5 1/2" L
Price/Each \$9.85



TYL032

1/4" DRIVE QUICK-RELEASE RATCHETS

Model No. TLV363 5 3/4" L
Price/Each \$23.95



TLV363

1/4" DRIVE HINGE HANDLES

Model No. TYL033 5 3/4" L
Price/Each \$8.75



TYL033

1/4" PLASTIC HANDLE DRIVERS

Model No. TLV445
Price/Each \$6.50



TLV445

1/4" DRIVE QUICK-RELEASE RUBBER GRIP RATCHETS

Model No. TLV380 6" L
Price/Each \$17.35



TLV380

EXTENSIONS

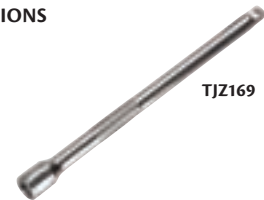

TJZ169

| Model No. | Overall Length" | Price /Each |
|-----------|-----------------|-------------|
| TYK843 | 2 | 2.30 |
| TLV446 | 4 | 3.20 |
| TJZ169 | 6 | 3.00 |

ADAPTORS



| Model No. | Size" | Price /Each |
|-----------|---------------|-------------|
| TYL035 | 1/4 F x 3/8 M | 2.60 |

1/4" DRIVE ACCESSORIES

6-POINT S.A.E STANDARD LENGTH SOCKETS



| Model No. | Hex Size" | Overall Length" | Price /Each |
|-----------|-----------|-----------------|-------------|
| TYK732 | 5/32 | 0.82 | 2.10 |
| TYK733 | 3/16 | 0.82 | 2.10 |
| TYK734 | 7/32 | 0.82 | 2.10 |
| TYK735 | 1/4 | 0.82 | 2.10 |
| TYK736 | 9/32 | 0.82 | 2.10 |
| TYK737 | 5/16 | 0.82 | 2.10 |
| TYK738 | 11/32 | 0.82 | 2.10 |
| TYK739 | 3/8 | 0.82 | 2.10 |
| TYK740 | 7/16 | 0.82 | 2.10 |
| TYK741 | 1/2 | 0.82 | 2.10 |
| TYK742 | 9/16 | 0.82 | 2.10 |

6-POINT S.A.E DEEP LENGTH SOCKETS



| Model No. | Hex Size" | Length" | Price /Each |
|-----------|-----------|---------|-------------|
| TYK791 | 5/32 | 1.94 | 2.30 |
| TYK792 | 3/16 | 1.94 | 2.30 |
| TYK793 | 7/32 | 1.94 | 2.30 |
| TLV496 | 1/4 | 1.94 | 2.30 |
| TYK794 | 9/32 | 1.94 | 2.30 |
| TYK795 | 5/16 | 1.94 | 2.30 |
| TYK796 | 11/32 | 1.94 | 2.30 |
| TYK797 | 3/8 | 1.94 | 2.30 |
| TYK798 | 7/16 | 1.94 | 2.35 |
| TYK799 | 1/2 | 1.94 | 2.45 |
| TYK800 | 9/16 | 1.94 | 2.75 |

6-POINT METRIC STANDARD LENGTH SOCKETS



| Model No. | Hex Size mm | Overall Length mm | Price /Each |
|-----------|-------------|-------------------|-------------|
| TYK743 | 4 | 21.3 | 2.10 |
| TYK744 | 4.5 | 21.3 | 2.10 |
| TYK745 | 5 | 21.3 | 2.10 |
| TYK746 | 5.5 | 21.3 | 2.10 |
| TYK747 | 6 | 21.3 | 2.10 |
| TYK748 | 7 | 21.3 | 2.10 |
| TYK591 | 8 | 21.3 | 2.10 |
| TYK750 | 9 | 21.3 | 2.10 |
| TYK592 | 10 | 21.3 | 2.10 |
| TYK752 | 11 | 21.3 | 2.10 |
| TYK753 | 12 | 21.3 | 2.10 |
| TYK754 | 13 | 21.3 | 2.10 |
| TYK755 | 14 | 21.3 | 2.10 |

6-POINT METRIC DEEP LENGTH SOCKETS



| Model No. | Hex Size mm | Length mm | Price /Each |
|-----------|-------------|-----------|-------------|
| TYK801 | 4 | 49.3 | 2.20 |
| TYK802 | 4.5 | 49.3 | 2.20 |
| TYK803 | 5 | 49.3 | 2.20 |
| TYK804 | 5.5 | 49.3 | 2.20 |
| TYK805 | 6 | 49.3 | 2.20 |
| TLV497 | 7 | 49.3 | 2.30 |
| TLV553 | 8 | 49.3 | 2.30 |
| TYK806 | 9 | 49.3 | 2.30 |
| TLV498 | 10 | 49.3 | 2.30 |
| TYK807 | 11 | 49.3 | 2.30 |
| TYK808 | 12 | 49.3 | 2.30 |
| TYK809 | 13 | 49.3 | 2.35 |
| TYK810 | 14 | 49.3 | 2.75 |

**Afraid of Heights...
We've Got You Covered!**



KLETON Canada's Leading Material Handling Supplier

SOCKET & ACCESSORIES



3/8" DRIVE RATCHETS

Model No. TNB484 7 7/8" L
Price/Each \$13.70



TNB484

3/8" DRIVE QUICK-RELEASE RATCHETS

Model No. TLV364 8" L Price/Each \$25.35



TLV364

3/8" DRIVE HINGE HANDLES

Model No. TYL037 9 1/2" L Price/Each \$11.70
Model No. TYL038 8 1/2" L Price/Each \$10.75



TYL037

3/8" DRIVE QUICK-RELEASE RUBBER GRIP RATCHET

Model No. TLV381 8" L
Price/Each \$21.45



TLV381

aurora tools

EXTENSIONS



| Model No. | Overall Length" | Price /Each |
|-----------|-----------------|-------------|
| TLV365 | 3 | 2.60 |
| TLV366 | 6 | 3.55 |
| TJZ226 | 8 | 4.45 |
| TYL040 | 10 | 6.20 |

ADAPTORS

| Model No. | Size" | Price /Each |
|-----------|---------------|-------------|
| TYL041 | 3/8 F x 1/4 M | 1.95 |
| TYK847 | 3/8 F x 1/2 M | 2.35 |



3/8" DRIVE ACCESSORIES

6-POINT S.A.E STANDARD LENGTH SOCKETS



| Model No. | Hex Size" | Length" | Price /Each |
|-----------|-----------|---------|-------------|
| TLV367 | 1/4 | 0.87 | 2.10 |
| TLV368 | 5/16 | 0.87 | 2.10 |
| TYK756 | 3/8 | 0.87 | 2.10 |
| TLV488 | 7/16 | 0.87 | 2.10 |
| TMB048 | 1/2 | 0.9 | 2.10 |
| TLV369 | 9/16 | 0.9 | 2.25 |
| TYK757 | 5/8 | 0.97 | 2.30 |
| TLV473 | 11/16 | 0.97 | 2.40 |
| TLV474 | 3/4 | 1.1 | 2.45 |
| TMB044 | 13/16 | 1.1 | 2.70 |
| TMB045 | 7/8 | 1.2 | 2.95 |

6-POINT S.A.E DEEP LENGTH SOCKETS



| Model No. | Hex Size" | Length" | Price /Each |
|-----------|-----------|---------|-------------|
| TYL048 | 1/4 | 1.95 | 2.65 |
| TYK811 | 5/16 | 1.95 | 2.90 |
| TYK812 | 3/8 | 2.43 | 2.90 |
| TLV370 | 7/16 | 2.43 | 2.95 |
| TLV371 | 1/2 | 2.43 | 3.15 |
| TLV372 | 9/16 | 2.43 | 3.60 |
| TMB047 | 5/8 | 2.43 | 3.75 |
| TLV475 | 11/16 | 2.43 | 4.00 |
| TLV373 | 3/4 | 2.43 | 4.70 |
| TLV374 | 13/16 | 2.46 | 5.45 |
| TLV476 | 7/8 | 2.46 | 5.60 |

SPARK PLUG SOCKETS



| Model No. | Hex Size" | Price /Each |
|-----------|-----------|-------------|
| TYL042 | 5/8 | 3.75 |
| TYL043 | 13/16 | 4.60 |

UNIVERSAL JOINTS



| Model No. | Price /Each |
|-----------|-------------|
| TYK844 | 6.50 |

6-POINT METRIC STANDARD LENGTH SOCKETS



| Model No. | Hex Size mm | Length mm | Price /Each |
|-----------|-------------|-----------|-------------|
| TYK758 | 6 | 22.1 | 2.00 |
| TYK759 | 7 | 22.1 | 2.00 |
| TYK760 | 8 | 22.1 | 2.00 |
| TYK761 | 9 | 22.1 | 2.00 |
| TMB046 | 10 | 22.1 | 2.00 |
| TYK762 | 11 | 22.1 | 2.00 |
| TMB049 | 12 | 22.9 | 2.00 |
| TMB052 | 13 | 22.9 | 2.20 |
| TYK764 | 14 | 22.9 | 2.30 |
| TYK765 | 15 | 22.9 | 2.35 |
| TYK766 | 16 | 24.7 | 2.40 |
| TYK767 | 17 | 24.7 | 2.40 |
| TJZ256 | 18 | 27.9 | 2.40 |
| TMB054 | 19 | 27.9 | 2.75 |
| TYL044 | 20 | 27.9 | 2.65 |
| TYL045 | 21 | 30.5 | 2.75 |
| TYL046 | 22 | 30.5 | 2.90 |

6-POINT METRIC DEEP LENGTH SOCKETS



| Model No. | Hex Size mm | Length mm | Price /Each |
|-----------|-------------|-----------|-------------|
| TYL050 | 6 | 50.8 | 2.60 |
| TYK593 | 7 | 50.8 | 2.70 |
| TYK813 | 8 | 50.8 | 2.70 |
| TYK814 | 9 | 61.7 | 2.70 |
| TYK815 | 10 | 61.7 | 2.80 |
| TYK816 | 11 | 61.7 | 2.80 |
| TMB053 | 12 | 61.7 | 2.95 |
| TYK817 | 13 | 61.7 | 3.05 |
| TYK818 | 14 | 61.7 | 3.25 |
| TYK819 | 15 | 61.7 | 3.60 |
| TYK820 | 16 | 61.7 | 3.60 |
| TYK821 | 17 | 61.7 | 3.70 |
| TYK822 | 18 | 61.7 | 3.70 |
| TYK823 | 19 | 61.7 | 3.70 |
| TYL052 | 20 | 71.5 | 3.85 |
| TYL053 | 21 | 71.5 | 3.85 |
| TYL054 | 22 | 73 | 4.05 |
| TYL055 | 23 | 73 | 4.75 |

ZENITH
Safety Products

Safety Products for Industry

3/8" DRIVE RATCHETS

Model No. **TI966** 7 3/8" L
 Mfg. No. 11-972 Price/Each \$54.40
 Model No. **UM211** 10 1/2" L
 Mfg. No. 11-973 Price/Each \$71.20



3/8" DRIVE FLEX HEAD RATCHETS

Model No. **UM212** 9 1/2" L
 Mfg. No. 11-974 Price/Each \$89.90



3/8" DRIVE HINGE HANDLES

Model No. **TI961** 8 1/2" L
 Mfg. No. 11-918 Price/Each \$37.20



3/8" DRIVE ACCESSORIES

6-POINT S.A.E. STANDARD LENGTH SOCKETS



| Model No. | Mfg. No. | Hex Size" | Overall Length" | Price /Each |
|-----------|----------|-----------|-----------------|-------------|
| UM108 | 11-008 | 1/4 | 0.87 | 7.71 |
| UM109 | 11-010 | 5/16 | 0.87 | 7.71 |
| UM111 | 11-012 | 3/8 | 0.87 | 7.73 |
| UM112 | 11-014 | 7/16 | 0.87 | 7.87 |
| UM113 | 11-016 | 1/2 | 0.90 | 7.98 |
| UM114 | 11-018 | 9/16 | 0.90 | 8.17 |
| UM115 | 11-020 | 5/8 | 0.97 | 8.29 |
| UM116 | 11-022 | 11/16 | 0.97 | 8.55 |
| UM117 | 11-024 | 3/4 | 1.10 | 8.95 |
| UM118 | 11-026 | 13/16 | 1.10 | 9.73 |
| UM119 | 11-028 | 7/8 | 1.20 | 10.50 |
| UM120 | 11-030 | 15/16 | 1.51 | 11.70 |
| UM121 | 11-032 | 1 | 1.58 | 12.40 |

6-POINT S.A.E. DEEP LENGTH SOCKETS



| Model No. | Mfg. No. | Hex Size" | Overall Length" | Price /Each |
|-----------|----------|-----------|-----------------|-------------|
| UM124 | 11-208 | 1/4 | 1.95 | 10.30 |
| UM125 | 11-210 | 5/16 | 1.95 | 10.90 |
| UM127 | 11-212 | 3/8 | 2.43 | 10.90 |
| UM128 | 11-214 | 7/16 | 2.43 | 10.90 |
| UM129 | 11-216 | 1/2 | 2.43 | 10.90 |
| UM130 | 11-218 | 9/16 | 2.43 | 11.60 |
| UM131 | 11-220 | 5/8 | 2.43 | 11.90 |
| UM132 | 11-222 | 11/16 | 2.43 | 13.10 |
| UM133 | 11-224 | 3/4 | 2.43 | 14.10 |
| UM134 | 11-226 | 13/16 | 2.46 | 15.30 |
| UM135 | 11-228 | 7/8 | 2.46 | 16.70 |
| UM136 | 11-230 | 15/16 | 2.50 | 19.80 |
| UM137 | 11-232 | 1 | 2.50 | 21.80 |

12-POINT S.A.E. STANDARD LENGTH SOCKETS



| Model No. | Mfg. No. | Hex Size" | Overall Length" | Price /Each |
|-----------|----------|-----------|-----------------|-------------|
| TI967 | 11-108 | 1/4 | 0.87 | 7.61 |
| TI968 | 11-110 | 5/16 | 0.87 | 7.71 |
| UG968 | 11-111 | 11/32 | 0.87 | 7.74 |
| TI969 | 11-112 | 3/8 | 0.87 | 7.66 |
| TI970 | 11-114 | 7/16 | 0.87 | 7.78 |
| TI971 | 11-116 | 1/2 | 0.90 | 7.98 |
| TI972 | 11-118 | 9/16 | 0.90 | 8.09 |
| TI973 | 11-120 | 5/8 | 0.97 | 8.19 |
| TI974 | 11-122 | 11/16 | 0.97 | 8.55 |
| TI975 | 11-124 | 3/4 | 1.10 | 8.55 |
| TI976 | 11-126 | 13/16 | 1.10 | 9.73 |
| TI977 | 11-128 | 7/8 | 1.20 | 10.40 |
| UM122 | 11-130 | 15/16 | 1.38 | 11.70 |
| UM123 | 11-132 | 1 | 1.38 | 12.40 |

12-POINT S.A.E. DEEP LENGTH SOCKETS



| Model No. | Mfg. No. | Hex Size" | Overall Length" | Price /Each |
|-----------|----------|-----------|-----------------|-------------|
| UM138 | 11-308 | 1/4 | 1.95 | 10.30 |
| UM139 | 11-310 | 5/16 | 1.95 | 10.80 |
| UM140 | 11-311 | 11/32 | 1.95 | 10.90 |
| TI978 | 11-312 | 3/8 | 2.43 | 10.80 |
| TI979 | 11-314 | 7/16 | 2.43 | 10.80 |
| TI980 | 11-316 | 1/2 | 2.43 | 10.80 |
| TI981 | 11-318 | 9/16 | 2.43 | 11.50 |
| TI982 | 11-320 | 5/8 | 2.43 | 11.90 |
| TI983 | 11-322 | 11/16 | 2.43 | 12.90 |
| TI984 | 11-324 | 3/4 | 2.43 | 13.90 |
| TI985 | 11-326 | 13/16 | 2.46 | 15.10 |
| TI986 | 11-328 | 7/8 | 2.46 | 16.50 |
| UM141 | 11-330 | 15/16 | 2.50 | 19.80 |
| UM142 | 11-332 | 1 | 2.50 | 21.60 |

6-POINT METRIC STANDARD LENGTH SOCKETS



| Model No. | Mfg. No. | Hex Size mm | Overall Length mm | Price /Each |
|-----------|----------|-------------|-------------------|-------------|
| UN586 | 38-006 | 6 | 22.1 | 8.15 |
| UN587 | 38-007 | 7 | 22.1 | 8.15 |
| UN588 | 38-008 | 8 | 22.1 | 8.15 |
| UN589 | 38-009 | 9 | 22.1 | 8.22 |
| UN590 | 38-010 | 10 | 22.1 | 8.26 |
| UN591 | 38-011 | 11 | 22.1 | 8.33 |
| UN592 | 38-012 | 12 | 22.9 | 8.41 |
| UN593 | 38-013 | 13 | 22.9 | 8.66 |
| UN594 | 38-014 | 14 | 22.9 | 8.45 |
| UN595 | 38-015 | 15 | 22.9 | 8.45 |
| UN596 | 38-016 | 16 | 24.7 | 8.45 |
| UN597 | 38-017 | 17 | 24.7 | 8.82 |
| UN598 | 38-018 | 18 | 27.9 | 8.82 |
| UN599 | 38-019 | 19 | 27.9 | 8.82 |
| UN600 | 38-020 | 20 | 27.9 | 9.25 |
| UN601 | 38-021 | 21 | 30.5 | 9.39 |
| UN602 | 38-022 | 22 | 30.5 | 9.73 |

6-POINT METRIC DEEP LENGTH SOCKETS



| Model No. | Mfg. No. | Hex Size mm | Overall Length mm | Price /Each |
|-----------|----------|-------------|-------------------|-------------|
| UN612 | 38-206 | 6 | 50.8 | 11.10 |
| UN613 | 38-207 | 7 | 50.8 | 11.10 |
| UN614 | 38-208 | 8 | 50.8 | 11.10 |
| UN615 | 38-209 | 9 | 61.7 | 11.20 |
| UN616 | 38-210 | 10 | 61.7 | 11.20 |
| UN617 | 38-211 | 11 | 61.7 | 11.20 |
| UN618 | 38-212 | 12 | 61.7 | 11.20 |
| UN619 | 38-213 | 13 | 61.7 | 11.20 |
| UN620 | 38-214 | 14 | 61.7 | 11.80 |
| UN621 | 38-215 | 15 | 61.7 | 11.80 |
| UN622 | 38-216 | 16 | 61.7 | 11.80 |
| UN623 | 38-217 | 17 | 61.7 | 11.80 |
| UN624 | 38-218 | 18 | 61.7 | 12.60 |
| UN625 | 38-219 | 19 | 61.7 | 13.50 |
| UN626 | 38-220 | 20 | 71.5 | 14.50 |
| UN627 | 38-221 | 21 | 71.5 | 15.10 |
| UN628 | 38-222 | 22 | 73.0 | 16.70 |

EXTENSIONS



| Model No. | Mfg. No. | Overall Length" | Price /Each |
|-----------|----------|-----------------|-------------|
| UM199 | 11-921 | 1 1/2 | 8.73 |
| TI962 | 11-922 | 3 | 13.90 |
| TI963 | 11-923 | 6 | 17.60 |
| UM200 | 11-925 | 8 | 19.40 |
| TI964 | 11-927 | 12 | 21.60 |
| UM202 | 11-928 | 20 | 27.20 |

SPEEDERS



| Model No. | Mfg. No. | Overall Length" | Price /Each |
|-----------|----------|-----------------|-------------|
| TI996 | 11-935 | 16 3/4 | 38.20 |

UNIVERSAL JOINTS

| Model No. | Mfg. No. | Price /Each |
|-----------|----------|-------------|
| TI965 | 11-947 | 31.10 |



ADAPTORS

| Model No. | Mfg. No. | Size" | Price /Each |
|-----------|----------|---------------|-------------|
| UM209 | 11-951 | 3/8 F x 1/4 M | 11.60 |
| UM210 | 11-952 | 3/8 F x 1/2 M | 9.92 |



12-POINT METRIC STANDARD LENGTH SOCKETS



| Model No. | Mfg. No. | Hex Size mm | Overall Length mm | Price /Each |
|-----------|----------|-------------|-------------------|-------------|
| UN605 | 38-106 | 6 | 22.2 | 8.15 |
| UN606 | 38-107 | 7 | 22.2 | 8.15 |
| TI937 | 38-108 | 8 | 22.2 | 8.15 |
| TI938 | 38-109 | 9 | 22.1 | 8.22 |
| TI939 | 38-110 | 10 | 22.1 | 8.26 |
| TI940 | 38-111 | 11 | 22.1 | 8.33 |
| TI941 | 38-112 | 12 | 22.9 | 8.41 |
| TI943 | 38-114 | 14 | 22.9 | 8.45 |
| TI944 | 38-115 | 15 | 22.9 | 8.45 |
| TI945 | 38-116 | 16 | 24.7 | 8.45 |
| TI946 | 38-117 | 17 | 24.7 | 8.82 |
| TI947 | 38-118 | 18 | 27.9 | 8.82 |
| TI948 | 38-119 | 19 | 27.9 | 8.82 |
| UN607 | 38-120 | 20 | 31.2 | 8.99 |
| UN609 | 38-122 | 22 | 34.9 | 9.73 |
| UN610 | 38-123 | 23 | 34.9 | 10.60 |
| UN611 | 38-126 | 26 | 41.3 | 12.10 |

12-POINT METRIC DEEP LENGTH SOCKETS



| Model No. | Mfg. No. | Hex Size mm | Overall Length mm | Price /Each |
|-----------|----------|-------------|-------------------|-------------|
| UN631 | 38-306 | 6 | 50.8 | 11.10 |
| UN632 | 38-307 | 7 | 50.8 | 11.10 |
| TI949 | 38-308 | 8 | 50.8 | 11.20 |
| TI950 | 38-309 | 9 | 61.7 | 11.20 |
| TI951 | 38-310 | 10 | 61.7 | 11.20 |
| TI952 | 38-311 | 11 | 61.7 | 11.20 |
| TI953 | 38-312 | 12 | 61.7 | 11.20 |
| TI955 | 38-314 | 14 | 61.7 | 11.80 |
| TI956 | 38-315 | 15 | 61.7 | 11.80 |
| TI957 | 38-316 | 16 | 61.7 | 11.80 |
| TI958 | 38-317 | 17 | 61.7 | 11.80 |
| TI959 | 38-318 | 18 | 61.7 | 12.60 |
| TI960 | 38-319 | 19 | 61.7 | 13.50 |
| UN633 | 38-320 | 20 | 71.5 | 14.50 |
| UN635 | 38-322 | 22 | 62.3 | 15.70 |
| UN636 | 38-323 | 23 | 73.0 | 19.10 |
| UN637 | 38-326 | 26 | 77.0 | 26.20 |

SOCKET & ACCESSORIES



1/2" DRIVE RATCHETS

Model No. TLV375 10" L
Price/Each \$24.95



TLV375

1/2" DRIVE QUICK-RELEASE RATCHETS

Model No. TLV376 10" L
Price/Each \$36.45



TLV376

1/2" DRIVE HINGE HANDLES

Model No. TTB977 14 1/4" L
Price/Each \$35.95



TTB977

1/2" DRIVE QUICK-RELEASE RUBBER GRIP RATCHETS

Model No. TLV382 10" L
Price/Each \$27.50



TLV382

aurora tools®

EXTENSIONS



| Model No. | Overall Length" | Price /Each |
|-----------|-----------------|-------------|
| TJZ297 | 3 | 2.65 |
| TLV377 | 5 | 4.55 |
| TJZ299 | 10 | 6.00 |

SPEEDERS



| Model No. | Overall Length" | Price /Each |
|-----------|-----------------|-------------|
| TNB489 | 16 1/2 | 13.60 |

1/2" DRIVE ACCESSORIES

6-POINT S.A.E STANDARD LENGTH SOCKETS



| Model No. | Hex Size" | Length" | Price /Each |
|-----------|-----------|---------|-------------|
| TYK768 | 3/8 | 1.46 | 2.45 |
| TYK769 | 7/16 | 1.46 | 2.65 |
| TTB978 | 1/2 | 1.46 | 2.70 |
| TMB050 | 9/16 | 1.46 | 2.70 |
| TYK771 | 5/8 | 1.46 | 2.70 |
| TYJ946 | 11/16 | 1.46 | 2.90 |
| TMB051 | 3/4 | 1.46 | 3.30 |
| TYK648 | 13/16 | 1.46 | 3.45 |
| TNB728 | 7/8 | 1.46 | 3.80 |
| TYL059 | 15/16 | 1.46 | 3.85 |
| TYK775 | 1 | 1.58 | 4.60 |
| TYL060 | 1 1/16 | 1.58 | 4.90 |
| TYL061 | 1 1/8 | 1.64 | 5.20 |
| TYL062 | 1 3/16 | 1.72 | 5.35 |
| TYL063 | 1 1/4 | 1.72 | 5.50 |

6-POINT S.A.E DEEP LENGTH SOCKETS



| Model No. | Hex Size" | Length" | Price /Each |
|-----------|-----------|---------|-------------|
| TYK824 | 7/16 | 3.19 | 4.60 |
| TYK825 | 1/2 | 3.19 | 4.60 |
| TYK826 | 9/16 | 3.19 | 4.60 |
| TYK827 | 5/8 | 3.21 | 4.60 |
| TYK828 | 11/16 | 3.21 | 4.60 |
| TYK829 | 3/4 | 3.21 | 4.60 |
| TYK830 | 13/16 | 3.21 | 5.80 |
| TYK831 | 7/8 | 3.21 | 5.85 |
| TLV379 | 15/16 | 3.21 | 6.80 |
| TYL067 | 1 | 3.21 | 7.45 |
| TYL068 | 1 1/16 | 3.21 | 8.25 |
| TYK649 | 1 1/8 | 3.21 | 10.60 |
| TYL069 | 1 1/4 | 3.21 | 11.60 |

6-POINT METRIC STANDARD LENGTH SOCKETS



| Model No. | Hex Size mm | Length mm | Price /Each |
|-----------|-------------|-----------|-------------|
| TYK776 | 10 | 38 | 2.65 |
| TYK777 | 11 | 38 | 2.65 |
| TYK778 | 12 | 38 | 2.65 |
| TYK779 | 13 | 38 | 2.65 |
| TYK780 | 14 | 38 | 2.75 |
| TYK781 | 15 | 38 | 2.75 |
| TYK782 | 16 | 38 | 2.75 |
| TYK783 | 17 | 38 | 2.75 |
| TYK784 | 18 | 38 | 3.10 |
| TYK785 | 19 | 38 | 3.45 |
| TYK786 | 20 | 38 | 3.45 |
| TYK787 | 21 | 38 | 3.50 |
| TYK788 | 22 | 38 | 3.80 |
| TYK789 | 23 | 38 | 3.85 |
| TYK790 | 24 | 38 | 4.20 |
| TYL064 | 27 | 44 | 4.55 |
| TYL065 | 30 | 44 | 6.45 |
| TYL066 | 32 | 44 | 6.65 |

6-POINT METRIC DEEP LENGTH SOCKETS



| Model No. | Hex Size mm | Length mm | Price /Each |
|-----------|-------------|-----------|-------------|
| TYK832 | 10 | 76.5 | 4.75 |
| TYK833 | 11 | 76.5 | 4.75 |
| TYK834 | 12 | 76.5 | 4.75 |
| TYK835 | 13 | 76.5 | 4.85 |
| TYK836 | 14 | 76.5 | 4.90 |
| TYL070 | 15 | 76.5 | 4.90 |
| TYK837 | 16 | 76.5 | 5.10 |
| TYK838 | 17 | 76.5 | 5.20 |
| TYL071 | 18 | 76.5 | 5.25 |
| TYK839 | 19 | 76.5 | 5.30 |
| TYK840 | 20 | 76.5 | 5.45 |
| TYK841 | 21 | 76.5 | 5.80 |
| TYK842 | 22 | 76.5 | 6.15 |
| TYL072 | 23 | 76.5 | 6.15 |
| TYL073 | 24 | 76.5 | 6.35 |
| TYL074 | 27 | 76.5 | 8.15 |
| TYL075 | 30 | 76.5 | 9.30 |
| TYL076 | 32 | 76.5 | 10.05 |

ADAPTORS

| Model No. | Size" | Price /Each |
|-----------|---------------|-------------|
| TYL056 | 1/2 F x 3/8 M | 3.20 |
| TJZ296 | 1/2 F x 3/4 M | 8.40 |



SPARK PLUG SOCKETS

| Model No. | Hex Size" | Price /Each |
|-----------|-----------|-------------|
| TJZ301 | 5/8 | 3.90 |
| TJZ302 | 13/16 | 4.25 |



UNIVERSAL JOINTS

| Model No. | Price /Each |
|-----------|-------------|
| TLV378 | 7.35 |



1/2" DRIVE RATCHETS

Model No. **TI550** 10 1/2" L
Mfg. No. 12-972 Price/Each \$83.90
Model No. **TI551** 15" L
Mfg. No. 12-973 Price/Each \$89.90



1/2" DRIVE FLEX HEAD RATCHETS

Model No. **TI552** 14 1/4" L
Mfg. No. 12-974 Price/Each \$110.00



1/2" DRIVE ACCESSORIES

6-POINT S.A.E. STANDARD LENGTH SOCKETS



| Model No. | Mfg. No. | Hex Size" | Overall Length" | Price /Each |
|-----------|----------|-----------|-----------------|-------------|
| TI384 | 12-012 | 3/8 | 1.46 | 10.70 |
| TI385 | 12-014 | 7/16 | 1.46 | 10.70 |
| TI386 | 12-016 | 1/2 | 1.46 | 10.70 |
| TI387 | 12-018 | 9/16 | 1.46 | 10.70 |
| TI388 | 12-020 | 5/8 | 1.46 | 11.10 |
| TI389 | 12-022 | 11/16 | 1.46 | 11.90 |
| TI390 | 12-024 | 3/4 | 1.46 | 11.90 |
| TI391 | 12-026 | 13/16 | 1.46 | 13.20 |
| TI392 | 12-028 | 7/8 | 1.46 | 13.20 |
| TI393 | 12-030 | 15/16 | 1.46 | 14.40 |
| TI394 | 12-032 | 1 | 1.58 | 15.30 |
| TI395 | 12-034 | 1 1/16 | 1.58 | 17.20 |
| TI396 | 12-036 | 1 1/8 | 1.64 | 19.90 |
| TI397 | 12-038 | 1 3/16 | 1.72 | 21.90 |
| TI398 | 12-040 | 1 1/4 | 1.72 | 23.40 |
| TI399 | 12-042 | 1 5/16 | 2.06 | 27.10 |
| TI400 | 12-044 | 1 3/8 | 2.13 | 31.40 |
| TI401 | 12-046 | 1 7/16 | 2.19 | 35.50 |
| TI402 | 12-048 | 1 1/2 | 2.25 | 37.60 |

6-POINT S.A.E. DEEP LENGTH SOCKETS



| Model No. | Mfg. No. | Hex Size" | Overall Length" | Price /Each |
|-----------|----------|-----------|-----------------|-------------|
| TI471 | 12-212 | 3/8 | 3.19 | 17.90 |
| TI472 | 12-214 | 7/16 | 3.19 | 17.90 |
| TI473 | 12-216 | 1/2 | 3.19 | 18.10 |
| TI474 | 12-218 | 9/16 | 3.19 | 18.20 |
| TI475 | 12-220 | 5/8 | 3.21 | 18.40 |
| TI476 | 12-222 | 11/16 | 3.21 | 18.50 |
| TI477 | 12-224 | 3/4 | 3.21 | 18.60 |
| TI478 | 12-226 | 13/16 | 3.21 | 20.30 |
| TI479 | 12-228 | 7/8 | 3.21 | 21.50 |
| TI480 | 12-230 | 15/16 | 3.21 | 23.90 |
| TI481 | 12-232 | 1 | 3.21 | 23.30 |
| TI482 | 12-234 | 1 1/16 | 3.21 | 25.70 |
| TI483 | 12-236 | 1 1/8 | 3.21 | 27.80 |
| TI484 | 12-238 | 1 3/16 | 3.22 | 32.90 |
| TI485 | 12-240 | 1 1/4 | 3.22 | 38.20 |
| TI486 | 12-242 | 1 5/16 | 3.22 | 39.90 |
| TI487 | 12-244 | 1 3/8 | 3.22 | 44.20 |
| TI488 | 12-246 | 1 7/16 | 3.22 | 49.60 |
| TI489 | 12-248 | 1 1/2 | 3.22 | 56.90 |

12-POINT METRIC STANDARD LENGTH SOCKETS



| Model No. | Mfg. No. | Hex Size mm | Overall Length mm | Price /Each |
|-----------|----------|-------------|-------------------|-------------|
| TI448 | 39-110 | 10 | 37 | 10.60 |
| TI449 | 39-111 | 11 | 37 | 10.60 |
| TI450 | 39-112 | 12 | 37 | 10.60 |
| TI451 | 39-113 | 13 | 37 | 10.60 |
| TI452 | 39-114 | 14 | 37 | 10.60 |
| TI453 | 39-115 | 15 | 37 | 10.60 |
| TI454 | 39-116 | 16 | 37 | 10.60 |
| TI455 | 39-117 | 17 | 37 | 11.50 |
| TI456 | 39-118 | 18 | 37 | 11.50 |
| TI457 | 39-119 | 19 | 37 | 11.50 |
| TI458 | 39-120 | 20 | 37 | 12.90 |
| TI459 | 39-121 | 21 | 37 | 12.90 |
| TI460 | 39-122 | 22 | 37 | 12.90 |
| TI461 | 39-123 | 23 | 37 | 14.10 |
| TI462 | 39-124 | 24 | 37 | 14.40 |
| TI463 | 39-125 | 25 | 37 | 15.30 |
| TI464 | 39-126 | 26 | 40 | 16.60 |
| TI465 | 39-127 | 27 | 40 | 16.90 |
| TI466 | 39-128 | 28 | 42 | 18.70 |
| TI467 | 39-129 | 29 | 42 | 19.90 |
| TI468 | 39-130 | 30 | 42 | 21.60 |
| TI469 | 39-132 | 32 | 44 | 25.90 |
| TI470 | 39-136 | 36 | 47 | 32.80 |

12-POINT METRIC DEEP LENGTH SOCKETS



| Model No. | Mfg. No. | Hex Size mm | Overall Length mm | Price /Each |
|-----------|----------|-------------|-------------------|-------------|
| TI509 | 39-310 | 10 | 81.4 | 17.90 |
| TI510 | 39-311 | 11 | 81.4 | 17.90 |
| TI511 | 39-312 | 12 | 81.4 | 18.10 |
| TI512 | 39-313 | 13 | 81.4 | 18.10 |
| TI513 | 39-314 | 14 | 81.4 | 18.20 |
| TI514 | 39-315 | 15 | 81.4 | 18.30 |
| TI515 | 39-316 | 16 | 81.4 | 18.40 |
| TI516 | 39-317 | 17 | 81.4 | 18.50 |
| TI517 | 39-318 | 18 | 81.4 | 18.50 |
| TI518 | 39-319 | 19 | 81.4 | 18.60 |
| TI519 | 39-320 | 20 | 81.4 | 20.30 |
| TI520 | 39-321 | 21 | 81.4 | 21.50 |
| TI521 | 39-322 | 22 | 81.4 | 21.50 |
| TI522 | 39-323 | 23 | 81.4 | 21.80 |
| TI523 | 39-324 | 24 | 82.2 | 22.40 |
| TI524 | 39-325 | 25 | 82.2 | 23.80 |
| TI525 | 39-326 | 26 | 82.2 | 26.30 |
| TI526 | 39-327 | 27 | 82.6 | 26.30 |
| TI527 | 39-328 | 28 | 82.6 | 27.90 |
| TI528 | 39-329 | 28 | 82.6 | 28.10 |
| TI529 | 39-330 | 30 | 82.6 | 31.10 |
| TI530 | 39-332 | 32 | 82.2 | 35.90 |

8-POINT S.A.E. STANDARD LENGTH SOCKETS



| Model No. | Mfg. No. | Hex Size" | Overall Length" | Price /Each |
|-----------|----------|-----------|-----------------|-------------|
| TI531 | 12-410 | 5/16 | 1.33 | 11.90 |
| TI532 | 12-412 | 3/8 | 1.33 | 11.90 |
| TI533 | 12-414 | 7/16 | 1.33 | 11.90 |
| TI534 | 12-416 | 1/2 | 1.33 | 11.90 |
| TI535 | 12-418 | 9/16 | 1.33 | 11.90 |
| TI536 | 12-420 | 5/8 | 1.33 | 11.90 |
| TI537 | 12-422 | 11/16 | 1.33 | 13.60 |
| TI538 | 12-424 | 3/4 | 1.33 | 13.70 |
| TI539 | 12-426 | 13/16 | 1.50 | 18.70 |
| TI540 | 12-428 | 7/8 | 1.63 | 21.30 |
| TI541 | 12-432 | 1 | 1.75 | 23.50 |

6-POINT METRIC STANDARD LENGTH SOCKETS



| Model No. | Mfg. No. | Hex Size mm | Overall Length mm | Price /Each |
|-----------|----------|-------------|-------------------|-------------|
| TI430 | 39-015 | 15 | 37 | 10.60 |
| TI431 | 39-016 | 16 | 37 | 10.60 |
| TI433 | 39-018 | 18 | 37 | 11.50 |
| TI434 | 39-019 | 19 | 37 | 11.50 |
| TI435 | 39-020 | 20 | 37 | 12.90 |
| TI436 | 39-021 | 21 | 37 | 12.90 |
| TI437 | 39-022 | 22 | 37 | 12.90 |
| TI438 | 39-023 | 23 | 38 | 14.10 |
| TI440 | 39-025 | 25 | 41 | 15.30 |
| TI442 | 39-027 | 27 | 46.1 | 17.90 |
| TI443 | 39-028 | 28 | 48.3 | 19.80 |
| TI444 | 39-029 | 29 | 49.5 | 21.40 |
| TI447 | 39-036 | 36 | 55.5 | 33.90 |



EXTENSIONS



| Model No. | Mfg. No. | Overall Length" | Price /Each |
|-----------|----------|-----------------|-------------|
| TI543 | 12-921 | 2 | 15.70 |
| TI544 | 12-923 | 5 | 21.20 |
| TI545 | 12-924 | 10 | 26.60 |
| TI546 | 12-927 | 20 | 46.80 |

UNIVERSAL JOINTS



| Model No. | Mfg. No. | Price /Each |
|-----------|----------|-------------|
| TI549 | 12-947 | 38.10 |

ADAPTORS



| Model No. | Mfg. No. | Size" | Price /Each |
|-----------|----------|---------------|-------------|
| TI547 | 12-951 | 1/2 F x 3/8 M | 12.60 |
| TI548 | 12-952 | 1/2 F x 3/4 M | 15.90 |

SPARK PLUG SOCKETS



| Model No. | Mfg. No. | Hex Size" | Overall Length" | Price /Each |
|-----------|----------|-----------|-----------------|-------------|
| TI542 | 12-504 | 13/16 | 2.50 | 18.30 |

12-POINT S.A.E. STANDARD LENGTH SOCKETS



| Model No. | Mfg. No. | Hex Size" | Overall Length" | Price /Each |
|-----------|----------|-----------|-----------------|-------------|
| TI403 | 12-112 | 3/8 | 1.46 | 10.70 |
| TI404 | 12-114 | 7/16 | 1.46 | 10.30 |
| TI405 | 12-116 | 1/2 | 1.46 | 10.30 |
| TI406 | 12-118 | 9/16 | 1.46 | 10.30 |
| TI407 | 12-119 | 19/32 | 1.46 | 10.50 |
| TI408 | 12-120 | 5/8 | 1.46 | 10.60 |
| TI409 | 12-121 | 21/32 | 1.46 | 11.30 |
| TI410 | 12-122 | 11/16 | 1.46 | 11.40 |
| TI411 | 12-124 | 3/4 | 1.46 | 11.40 |
| TI412 | 12-125 | 25/32 | 1.46 | 12.10 |
| TI413 | 12-126 | 13/16 | 1.46 | 12.90 |
| TI414 | 12-128 | 7/8 | 1.46 | 12.90 |
| TI415 | 12-130 | 15/16 | 1.46 | 13.80 |
| TI416 | 12-132 | 1 | 1.58 | 14.70 |
| TI417 | 12-134 | 1 1/16 | 1.58 | 16.50 |
| TI418 | 12-136 | 1 1/8 | 1.64 | 18.60 |
| TI419 | 12-138 | 1 3/16 | 1.72 | 21.10 |
| TI420 | 12-140 | 1 1/4 | 1.72 | 22.40 |
| TI421 | 12-142 | 1 5/16 | 2.06 | 25.90 |
| TI422 | 12-144 | 1 3/8 | 2.13 | 29.90 |
| TI423 | 12-146 | 1 7/16 | 2.19 | 33.90 |
| TI424 | 12-148 | 1 1/2 | 2.19 | 37.50 |

12-POINT S.A.E. DEEP LENGTH SOCKETS



| Model No. | Mfg. No. | Hex Size" | Overall Length" | Price /Each |
|-----------|----------|-----------|-----------------|-------------|
| TI490 | 12-312 | 3/8 | 3.19 | 17.90 |
| TI491 | 12-314 | 7/16 | 3.19 | 17.90 |
| TI492 | 12-316 | 1/2 | 3.19 | 18.10 |
| TI493 | 12-318 | 9/16 | 3.19 | 18.20 |
| TI494 | 12-320 | 5/8 | 3.21 | 18.40 |
| TI495 | 12-322 | 11/16 | 3.21 | 18.50 |
| TI496 | 12-324 | 3/4 | 3.21 | 18.60 |
| TI497 | 12-326 | 13/16 | 3.21 | 20.30 |
| TI498 | 12-328 | 7/8 | 3.21 | 21.50 |
| TI499 | 12-330 | 15/16 | 3.21 | 22.40 |
| TI500 | 12-332 | 1 | 3.21 | 23.30 |
| TI502 | 12-336 | 1 1/8 | 3.21 | 27.80 |
| TI503 | 12-338 | 1 3/16 | 3.24 | 33.20 |
| TI504 | 12-340 | 1 1/4 | 3.24 | 33.60 |
| TI505 | 12-342 | 1 5/16 | 3.24 | 41.50 |
| TI506 | 12-344 | 1 3/8 | 3.24 | 44.20 |
| TI507 | 12-346 | 1 7/16 | 3.24 | 49.60 |
| TI508 | 12-348 | 1 1/2 | 3.24 | 56.90 |

SOCKET & ACCESSORIES



3/4" DRIVE RATCHETS

Model No. WJ148 19" L
Mfg. No. 13-972
Price/Each \$169.00



3/4" DRIVE HINGE HANDLES

Model No. UM332 22" L
Mfg. No. 13-918 Price/Each \$116.00



3/4" DRIVE T-HANDLES

Model No. VE959 20" L
Mfg. No. 13-938 Price/Each \$77.20



3/4" DRIVE ACCESSORIES



12-POINT S.A.E.
STANDARD LENGTH SOCKETS

| Model No. | Mfg. No. | Hex Size" | Overall Length" | Price /Each |
|-----------|----------|-----------|-----------------|-------------|
| UM274 | 13-124 | 3/4 | 1.9 | 24.60 |
| UM275 | 13-126 | 13/16 | 1.94 | 25.30 |
| UM276 | 13-128 | 7/8 | 1.97 | 25.90 |
| VE939 | 13-130 | 15/16 | 1.97 | 25.60 |
| VE940 | 13-132 | 1 | 2.00 | 26.90 |
| VE941 | 13-134 | 1 1/16 | 2.09 | 26.50 |
| VE942 | 13-136 | 1 1/8 | 2.13 | 26.50 |
| UM277 | 13-138 | 1 3/16 | 2.19 | 26.60 |
| VE943 | 13-140 | 1 1/4 | 2.19 | 28.40 |
| VE944 | 13-142 | 1 5/16 | 2.23 | 31.50 |
| VE945 | 13-144 | 1 3/8 | 2.23 | 35.10 |
| VE946 | 13-146 | 1 7/16 | 2.3 | 38.40 |
| VE947 | 13-148 | 1 1/2 | 2.3 | 41.10 |
| UM278 | 13-150 | 1 9/16 | 2.4 | 45.90 |
| VE948 | 13-152 | 1 5/8 | 2.49 | 47.20 |
| VE949 | 13-154 | 1 11/16 | 2.49 | 51.10 |
| VE950 | 13-156 | 1 3/4 | 2.64 | 51.50 |
| VE951 | 13-158 | 1 13/16 | 2.8 | 55.60 |
| VE952 | 13-160 | 1 7/8 | 2.86 | 61.80 |
| VE953 | 13-164 | 2 | 2.99 | 69.90 |
| UM280 | 13-166 | 2 1/16 | 3.02 | 81.50 |
| VE954 | 13-168 | 2 1/8 | 3.05 | 83.40 |
| UM281 | 13-170 | 2 3/16 | 3.05 | 89.30 |
| VE955 | 13-172 | 2 1/4 | 3.17 | 99.90 |
| UM282 | 13-174 | 2 5/16 | 3.24 | 116.00 |
| UM283 | 13-176 | 2 3/8 | 3.24 | 122.00 |

12-POINT METRIC
STANDARD LENGTH SOCKETS

| Model No. | Mfg. No. | Hex Size mm | Overall Length mm | Price /Each |
|-----------|----------|-------------|-------------------|-------------|
| UN666 | 40-119 | 19 | 49.2 | 26.90 |
| UN667 | 40-120 | 20 | 49.2 | 26.90 |
| UN668 | 40-121 | 21 | 50 | 26.90 |
| UN669 | 40-122 | 22 | 50 | 26.90 |
| UN670 | 40-123 | 23 | 50 | 27.20 |
| UN671 | 40-124 | 24 | 50 | 27.20 |
| UN672 | 40-125 | 25 | 50.8 | 27.20 |
| UN673 | 40-126 | 26 | 52.4 | 28.20 |
| UN674 | 40-127 | 27 | 53.2 | 28.30 |
| UN675 | 40-128 | 28 | 53.8 | 28.30 |
| UN676 | 40-129 | 29 | 53.8 | 28.20 |
| UN677 | 40-130 | 30 | 55.6 | 29.90 |
| UN678 | 40-132 | 32 | 55.1 | 35.20 |
| UN679 | 40-135 | 35 | 56.8 | 36.20 |
| UN680 | 40-136 | 36 | 58.3 | 37.20 |
| UN681 | 40-138 | 38 | 59.9 | 41.90 |
| UN682 | 40-141 | 41 | 63.9 | 49.90 |
| UN683 | 40-142 | 42 | 64.6 | 51.90 |
| UN684 | 40-146 | 46 | 71 | 66.70 |
| UN685 | 40-150 | 50 | 75.8 | 75.50 |
| UN686 | 40-154 | 54 | 77.2 | 89.90 |
| UN687 | 40-155 | 55 | 79.8 | 110.00 |
| UN688 | 40-158 | 58 | 82.2 | 112.00 |
| UN689 | 40-160 | 60 | 82.2 | 127.00 |



12-POINT S.A.E.
DEEP LENGTH SOCKETS

| Model No. | Mfg. No. | Hex Size" | Overall Length" | Price /Each |
|-----------|----------|-----------|-----------------|-------------|
| UM292 | 13-328 | 7/8 | 3.38 | 38.20 |
| UM293 | 13-330 | 15/16 | 3.38 | 38.30 |
| UM294 | 13-332 | 1 | 3.38 | 38.80 |
| UM295 | 13-334 | 1 1/16 | 3.50 | 39.90 |
| UM296 | 13-336 | 1 1/8 | 3.50 | 39.90 |
| UM297 | 13-340 | 1 1/4 | 3.50 | 41.10 |
| UM298 | 13-342 | 1 5/16 | 3.50 | 42.60 |
| UM299 | 13-344 | 1 3/8 | 3.50 | 48.20 |
| UM300 | 13-346 | 1 7/16 | 3.50 | 51.50 |
| UM301 | 13-348 | 1 1/2 | 3.50 | 53.90 |
| UM302 | 13-352 | 1 5/8 | 3.50 | 65.50 |



12-POINT METRIC
DEEP LENGTH SOCKETS

| Model No. | Mfg. No. | Hex Size mm | Overall Length mm | Price /Each |
|-----------|----------|-------------|-------------------|-------------|
| UN690 | 40-319 | 19 | 85.7 | 41.40 |
| UN691 | 40-322 | 22 | 85.7 | 41.40 |
| UN692 | 40-323 | 23 | 85.7 | 41.40 |
| UN693 | 40-324 | 24 | 85.7 | 41.50 |
| UN694 | 40-327 | 27 | 88.9 | 42.20 |
| UN695 | 40-330 | 30 | 88.9 | 43.90 |
| UN696 | 40-332 | 32 | 88.9 | 42.90 |
| UN697 | 40-335 | 35 | 88.9 | 51.90 |
| UN698 | 40-336 | 36 | 88.9 | 54.80 |
| UN699 | 40-338 | 38 | 88.9 | 58.30 |
| UN700 | 40-341 | 41 | 88.9 | 69.20 |
| UN701 | 40-346 | 46 | 88.9 | 81.10 |
| UN702 | 40-350 | 50 | 101.6 | 94.60 |
| UN703 | 40-355 | 55 | 108 | 116.00 |
| UN704 | 40-360 | 60 | 114.3 | 129.00 |

ARMSTRONG
INDUSTRIAL HAND TOOLS

EXTENSIONS

| Model No. | Mfg. No. | Overall Length" | Price /Each |
|-----------|----------|-----------------|-------------|
| UM333 | 13-922 | 5 | 41.20 |
| VE960 | 13-923 | 8 | 51.10 |
| VE961 | 13-925 | 16 | 79.90 |



UNIVERSAL JOINTS

| Model No. | Mfg. No. | Price /Each |
|-----------|----------|-------------|
| VE962 | 13-947 | 107.00 |



ADAPTORS

| Model No. | Mfg. No. | Size" | Price /Each |
|-----------|----------|---------------|-------------|
| VE956 | 13-951 | 3/4 F x 1/2 M | 25.90 |
| UM334 | 13-952 | 3/4 F x 1 M | 36.40 |



IMPACT SOCKETS & ACCESSORIES

3/8" DRIVE STANDARD LENGTH 6-POINT



| Model No. | Mfg. No. | Size | Overall Length | Price /Each |
|-----------|----------|--------|----------------|-------------|
| S.A.E. | | | | |
| TDR567 | 19-608 | 1/4" | 1.10" | 7.26 |
| TDR568 | 19-610 | 5/16" | 1.10" | 7.55 |
| TDR563 | 19-612 | 3/8" | 1.10" | 7.44 |
| TDR562 | 19-614 | 7/16" | 1.10" | 7.76 |
| TDR561 | 19-616 | 1/2" | 1.10" | 7.55 |
| TDR558 | 19-618 | 9/16" | 1.10" | 7.76 |
| TDR557 | 19-620 | 5/8" | 1.10" | 7.76 |
| TDR555 | 19-622 | 11/16" | 1.10" | 7.76 |
| TDR554 | 19-624 | 3/4" | 1.10" | 7.86 |

METRIC

| | | | | |
|--------|--------|-------|-------|------|
| TDR545 | 46-607 | 7 mm | 28 mm | 7.96 |
| TDR546 | 46-608 | 8 mm | 28 mm | 7.96 |
| TDR547 | 46-609 | 9 mm | 28 mm | 7.96 |
| TDR548 | 46-610 | 10 mm | 28 mm | 7.96 |
| TDR549 | 46-611 | 11 mm | 28 mm | 7.96 |
| TDR550 | 46-612 | 12 mm | 28 mm | 7.96 |
| TDR551 | 46-613 | 13 mm | 28 mm | 7.96 |
| TDR552 | 46-614 | 14 mm | 28 mm | 7.96 |
| TDR553 | 46-615 | 15 mm | 28 mm | 7.96 |
| TDR538 | 46-616 | 16 mm | 28 mm | 8.12 |
| TDR532 | 46-617 | 17 mm | 28 mm | 8.57 |
| TDR534 | 46-619 | 19 mm | 30 mm | 8.97 |

3/8" DRIVE DEEP LENGTH 6-POINT



| Model No. | Mfg. No. | Size | Overall Length | Price /Each |
|-----------|----------|--------|----------------|-------------|
| S.A.E. | | | | |
| TDR542 | 19-708 | 1/4" | 2.48" | 9.42 |
| TDR544 | 19-710 | 5/16" | 2.48" | 9.32 |
| TDR541 | 19-712 | 3/8" | 2.48" | 9.52 |
| TDR539 | 19-714 | 7/16" | 2.48" | 9.82 |
| TDR536 | 19-716 | 1/2" | 2.48" | 9.90 |
| TDR535 | 19-718 | 9/16" | 2.79" | 10.60 |
| TDR528 | 19-720 | 5/8" | 2.79" | 10.40 |
| TDR523 | 19-722 | 11/16" | 2.79" | 11.10 |
| TDR522 | 19-724 | 3/4" | 2.79" | 11.20 |
| TDR484 | 19-728 | 7/8" | 2.79" | 12.40 |
| TDR482 | 19-730 | 15/16" | 2.79" | 15.80 |
| TDR478 | 19-732 | 1" | 2.79" | 15.90 |

METRIC

| | | | | |
|--------|--------|-------|---------|-------|
| TDR521 | 46-708 | 8 mm | 63.9 mm | 10.20 |
| TDR514 | 46-709 | 9 mm | 63.9 mm | 10.40 |
| TDR515 | 46-710 | 10 mm | 63.9 mm | 10.80 |
| TDR516 | 46-711 | 11 mm | 63.9 mm | 10.40 |
| TDR517 | 46-712 | 12 mm | 63.9 mm | 10.40 |
| TDR518 | 46-713 | 13 mm | 63.9 mm | 10.40 |
| TDR519 | 46-714 | 14 mm | 63.9 mm | 10.40 |
| TDR520 | 46-715 | 15 mm | 71 mm | 10.40 |
| TDR509 | 46-716 | 16 mm | 71 mm | 10.70 |

3/8" DRIVE 6-POINT UNIVERSAL



| Model No. | Mfg. No. | Size" | Overall Length" | Price /Each |
|-----------|----------|-------|-----------------|-------------|
| UM626 | 19-562 | 3/8 | 2.19 | 39.80 |
| UM628 | 19-566 | 1/2 | 2.19 | 39.80 |
| UM630 | 19-570 | 5/8 | 2.19 | 39.80 |
| UM632 | 19-574 | 3/4 | 2.19 | 41.80 |

3/8" DRIVE EXTENSIONS



| Model No. | Mfg. No. | Overall Length" | Price /Each |
|-----------|----------|-----------------|-------------|
| UM639 | 19-922 | 3.000 | 14.30 |
| UM640 | 19-923 | 6.000 | 17.90 |

3/8" DRIVE DRIVE ADAPTORS



| Model No. | Mfg. No. | Overall Length" | Size" | Price /Each |
|-----------|----------|-----------------|---------------|-------------|
| UM642 | 19-952 | 1.375 | 3/8 F x 1/2 M | 13.80 |

3/8" DRIVE UNIVERSAL JOINTS



| Model No. | Mfg. No. | Rotation | Price /Each |
|-----------|----------|----------|-------------|
| UM641 | 19-947 | 25° | 41.60 |



1/2" DRIVE STANDARD LENGTH 6-POINT



| Model No. | Mfg. No. | Size | Overall Length | Price /Each |
|-----------|----------|---------|----------------|-------------|
| S.A.E. | | | | |
| T1727 | 20-012 | 3/8" | 1.50" | 9.23 |
| T1728 | 20-014 | 7/16" | 1.50" | 9.23 |
| T1729 | 20-016 | 1/2" | 1.50" | 9.23 |
| T1730 | 20-018 | 9/16" | 1.50" | 9.23 |
| T1731 | 20-020 | 5/8" | 1.50" | 9.23 |
| T1732 | 20-022 | 11/16" | 1.50" | 9.90 |
| T1733 | 20-024 | 3/4" | 1.61" | 10.30 |
| T1734 | 20-026 | 13/16" | 1.61" | 11.90 |
| T1735 | 20-028 | 7/8" | 1.75" | 12.60 |
| T1736 | 20-030 | 15/16" | 1.75" | 14.90 |
| T1737 | 20-032 | 1" | 1.75" | 15.60 |
| T1738 | 20-034 | 1 1/16" | 1.75" | 17.60 |
| T1739 | 20-036 | 1 1/8" | 2.00" | 18.30 |
| T1740 | 20-038 | 1 3/16" | 2.03" | 19.60 |
| T1741 | 20-040 | 1 1/4" | 2.03" | 22.60 |
| T1742 | 20-042 | 1 5/16" | 2.03" | 27.10 |
| T1743 | 20-044 | 1 3/8" | 2.13" | 27.10 |
| T1744 | 20-046 | 1 7/16" | 2.19" | 29.90 |
| T1745 | 20-048 | 1 1/2" | 2.19" | 38.10 |

METRIC

| | | | | |
|-------|--------|-------|-------|-------|
| T1746 | 47-009 | 9 mm | 38 mm | 9.42 |
| T1747 | 47-010 | 10 mm | 38 mm | 9.42 |
| T1748 | 47-011 | 11 mm | 38 mm | 9.42 |
| T1749 | 47-012 | 12 mm | 38 mm | 9.42 |
| T1750 | 47-013 | 13 mm | 38 mm | 9.42 |
| T1751 | 47-014 | 14 mm | 38 mm | 9.42 |
| T1752 | 47-015 | 15 mm | 38 mm | 9.64 |
| T1753 | 47-016 | 16 mm | 38 mm | 9.87 |
| T1754 | 47-017 | 17 mm | 38 mm | 10.20 |
| T1755 | 47-018 | 18 mm | 38 mm | 10.20 |
| T1756 | 47-019 | 19 mm | 38 mm | 10.90 |
| T1757 | 47-020 | 20 mm | 41 mm | 11.60 |
| T1758 | 47-021 | 21 mm | 41 mm | 12.40 |
| T1759 | 47-022 | 22 mm | 41 mm | 13.80 |
| T1760 | 47-023 | 23 mm | 45 mm | 14.60 |
| T1761 | 47-024 | 24 mm | 45 mm | 16.30 |
| T1762 | 47-025 | 25 mm | 45 mm | 19.50 |
| T1763 | 47-026 | 26 mm | 51 mm | 20.30 |
| T1764 | 47-027 | 27 mm | 51 mm | 19.90 |
| T1765 | 47-030 | 30 mm | 52 mm | 22.20 |

1/2" DRIVE DEEP LENGTH 6-POINT



| Model No. | Mfg. No. | Size | Overall Length | Price /Each |
|-----------|----------|---------|----------------|-------------|
| S.A.E. | | | | |
| T1766 | 20-212 | 3/8" | 3.23" | 14.10 |
| T1767 | 20-214 | 7/16" | 3.23" | 14.10 |
| T1768 | 20-216 | 1/2" | 3.27" | 14.10 |
| T1769 | 20-218 | 9/16" | 3.27" | 14.50 |
| T1770 | 20-220 | 5/8" | 3.27" | 14.60 |
| T1771 | 20-222 | 11/16" | 3.27" | 15.20 |
| T1772 | 20-224 | 3/4" | 3.27" | 15.70 |
| T1773 | 20-226 | 13/16" | 3.27" | 16.50 |
| T1774 | 20-228 | 7/8" | 3.27" | 19.10 |
| T1775 | 20-230 | 15/16" | 3.27" | 18.90 |
| T1776 | 20-232 | 1" | 3.25" | 20.60 |
| T1777 | 20-234 | 1 1/16" | 3.25" | 24.70 |
| T1778 | 20-236 | 1 1/8" | 3.50" | 29.40 |
| T1780 | 20-240 | 1 1/4" | 3.50" | 31.30 |
| T1781 | 20-242 | 1 5/16" | 3.50" | 36.10 |
| T1782 | 20-244 | 1 3/8" | 3.50" | 39.70 |
| T1783 | 20-246 | 1 7/16" | 3.50" | 44.20 |
| T1784 | 20-248 | 1 1/2" | 3.50" | 52.10 |

METRIC

| | | | | |
|-------|--------|-------|-------|-------|
| T1785 | 47-209 | 9 mm | 82 mm | 15.60 |
| T1786 | 47-210 | 10 mm | 82 mm | 15.20 |
| T1787 | 47-211 | 11 mm | 82 mm | 15.20 |
| T1788 | 47-212 | 12 mm | 82 mm | 15.60 |
| T1789 | 47-213 | 13 mm | 82 mm | 15.30 |
| T1790 | 47-214 | 14 mm | 82 mm | 15.30 |
| T1791 | 47-215 | 15 mm | 82 mm | 15.60 |
| T1792 | 47-216 | 16 mm | 82 mm | 16.80 |
| T1793 | 47-217 | 17 mm | 82 mm | 16.80 |
| T1794 | 47-218 | 18 mm | 82 mm | 16.80 |
| T1795 | 47-219 | 19 mm | 82 mm | 16.80 |
| T1796 | 47-220 | 20 mm | 82 mm | 18.30 |
| T1797 | 47-221 | 21 mm | 82 mm | 19.90 |
| T1798 | 47-222 | 22 mm | 82 mm | 20.40 |
| T1799 | 47-223 | 23 mm | 82 mm | 21.40 |
| T1800 | 47-224 | 24 mm | 82 mm | 22.80 |
| T1801 | 47-225 | 25 mm | 83 mm | 26.90 |
| T1802 | 47-226 | 26 mm | 83 mm | 26.50 |
| T1803 | 47-227 | 27 mm | 83 mm | 26.80 |
| T1804 | 47-230 | 30 mm | 89 mm | 27.90 |

1/2" DRIVE EXTENSIONS



| Model No. | Mfg. No. | Length" | Price /Each |
|-----------|----------|---------|-------------|
| T1805 | 20-923 | 5 | 18.90 |
| T1806 | 20-924 | 10 | 23.50 |

1/2" DRIVE UNIVERSAL JOINTS



| Model No. | Mfg. No. | Price /Each |
|-----------|----------|-------------|
| T1807 | 20-947 | 46.80 |

1/2" DRIVE ADAPTORS



| Model No. | Mfg. No. | Overall Length" | Size" | Price /Each |
|-----------|----------|-----------------|---------------|-------------|
| T1808 | 20-951 | 1.50 | 1/2 F x 3/8 M | 14.10 |
| T1809 | 20-952 | 1.81 | 1/2 F x 3/4 M | 26.50 |
| T1810 | 20-953 | 1.69 | 1/2 F x 5/8 M | 18.20 |
| T1811 | 20-996 | 1.88 | 5/8 F x 1/2 M | 25.60 |



IMPACT SOCKETS & ACCESSORIES



3/4" DRIVE STANDARD LENGTH 6 POINT



| Model No. | Mfg. No. | Size | Overall Length | Price /Each |
|---------------|----------|----------|----------------|-------------|
| S.A.E. | | | | |
| TI814 | 21-016 | 1/2" | 1.81" | 21.70 |
| TI815 | 21-018 | 9/16" | 1.81" | 21.80 |
| TI816 | 21-020 | 5/8" | 1.81" | 21.80 |
| TI817 | 21-022 | 11/16" | 1.88" | 21.80 |
| TI818 | 21-024 | 3/4" | 1.88" | 22.10 |
| TI819 | 21-026 | 13/16" | 1.91" | 24.90 |
| TI820 | 21-028 | 7/8" | 2.00" | 24.90 |
| TI821 | 21-030 | 15/16" | 2.00" | 24.90 |
| TI822 | 21-032 | 1" | 2.00" | 25.30 |
| TI823 | 21-034 | 1 1/16" | 2.06" | 26.90 |
| TI824 | 21-036 | 1 1/8" | 2.13" | 28.60 |
| TI825 | 21-038 | 13/16" | 2.13" | 28.90 |
| TI826 | 21-040 | 1 1/4" | 2.13" | 29.90 |
| TI827 | 21-042 | 1 5/16" | 2.13" | 31.10 |
| TI828 | 21-044 | 1 3/8" | 2.25" | 32.10 |
| TI829 | 21-046 | 1 7/16" | 2.25" | 34.10 |
| TI830 | 21-048* | 1 1/2" | 2.25" | 36.70 |
| TI831 | 21-052 | 1 5/8" | 2.38" | 38.60 |
| TI832 | 21-054 | 1 11/16" | 2.38" | 37.90 |

METRIC

| | | | | |
|-------|--------|-------|-------|-------|
| TI833 | 48-019 | 19 mm | 48 mm | 21.40 |
| TI834 | 48-020 | 20 mm | 49 mm | 21.40 |
| TI835 | 48-021 | 21 mm | 49 mm | 21.40 |
| TI836 | 48-022 | 22 mm | 50 mm | 22.40 |
| TI837 | 48-023 | 23 mm | 51 mm | 23.10 |
| TI838 | 48-024 | 24 mm | 51 mm | 23.90 |
| TI839 | 48-025 | 25 mm | 51 mm | 24.50 |
| TI840 | 48-026 | 26 mm | 51 mm | 25.10 |
| TI841 | 48-027 | 27 mm | 51 mm | 25.70 |
| TI842 | 48-030 | 30 mm | 54 mm | 28.60 |
| TI843 | 48-032 | 32 mm | 54 mm | 31.10 |
| TI844 | 48-036 | 36 mm | 57 mm | 33.40 |
| TI845 | 48-041 | 41 mm | 60 mm | 42.80 |
| TI846 | 48-046 | 46 mm | 65 mm | 57.10 |
| TI847 | 48-050 | 50 mm | 68 mm | 72.10 |

3/4" DRIVE DEEP LENGTH 6-POINT



| Model No. | Mfg. No. | Size | Overall Length | Price /Each |
|---------------|----------|----------|----------------|-------------|
| S.A.E. | | | | |
| TI848 | 21-218 | 9/16" | 3.25" | 32.50 |
| TI849 | 21-220 | 5/8" | 3.25" | 32.40 |
| TI850 | 21-222 | 11/16" | 3.25" | 32.50 |
| TI851 | 21-224 | 3/4" | 3.25" | 33.40 |
| TI852 | 21-226 | 13/16" | 3.25" | 33.40 |
| TI853 | 21-228 | 7/8" | 3.25" | 34.70 |
| TI854 | 21-230 | 15/16" | 3.25" | 36.20 |
| TI855 | 21-232 | 1" | 3.25" | 37.60 |
| TI856 | 21-234 | 1 1/16" | 3.25" | 38.60 |
| TI857 | 21-236 | 1 1/8" | 3.25" | 38.60 |
| TI858 | 21-238 | 1 3/16" | 3.25" | 39.30 |
| TI859 | 21-240 | 1 1/4" | 3.25" | 42.30 |
| TI860 | 21-242 | 1 5/16" | 3.38" | 43.20 |
| TI861 | 21-244 | 1 3/8" | 3.5" | 46.50 |
| TI862 | 21-246 | 1 7/16" | 3.5" | 51.10 |
| TI863 | 21-248* | 1 1/2" | 3.5" | 51.20 |
| TI864 | 21-252 | 1 5/8" | 3.5" | 54.60 |
| TI865 | 21-254 | 1 11/16" | 3.5" | 54.70 |

METRIC

| | | | | |
|-------|--------|-------|-------|-------|
| TI866 | 48-221 | 21 mm | 83 mm | 33.20 |
| TI867 | 48-222 | 22 mm | 83 mm | 33.90 |
| TI868 | 48-223 | 23 mm | 89 mm | 33.30 |
| TI869 | 48-224 | 24 mm | 89 mm | 35.40 |
| TI870 | 48-226 | 26 mm | 89 mm | 35.60 |
| TI871 | 48-227 | 27 mm | 89 mm | 35.60 |
| TI872 | 48-230 | 30 mm | 89 mm | 39.80 |
| TI873 | 48-232 | 32 mm | 89 mm | 41.30 |
| TI874 | 48-236 | 36 mm | 89 mm | 47.40 |
| TI875 | 48-241 | 41 mm | 89 mm | 56.40 |

1" DRIVE STANDARD LENGTH 6-POINT



| Model No. | Mfg. No. | Size" | Overall Length" | Price /Each |
|-----------|----------|---------|-----------------|-------------|
| UM746 | 22-024 | 3/4 | 2.25 | 37.10 |
| UM747 | 22-026 | 13/16 | 2.25 | 37.10 |
| UM748 | 22-028 | 7/8 | 2.25 | 37.30 |
| UM749 | 22-030 | 15/16 | 2.38 | 37.40 |
| UM750 | 22-032 | 1 | 2.38 | 39.90 |
| UM751 | 22-034 | 1 1/16 | 2.38 | 39.90 |
| UM752 | 22-036 | 1 1/8 | 2.44 | 39.90 |
| UM753 | 22-038 | 1 3/16 | 2.5 | 39.90 |
| UM754 | 22-040 | 1 1/4 | 2.5 | 39.90 |
| UM755 | 22-042 | 1 5/16 | 2.562 | 39.90 |
| UM756 | 22-044 | 1 3/8 | 2.562 | 41.20 |
| UM757 | 22-046 | 1 7/16 | 2.562 | 42.40 |
| UM758 | 22-048* | 1 1/2 | 2.625 | 44.50 |
| UM759 | 22-050 | 1 9/16 | 2.625 | 45.90 |
| UM760 | 22-052 | 1 5/8 | 2.625 | 48.90 |
| UM761 | 22-054 | 1 11/16 | 2.687 | 48.30 |
| UM762 | 22-056* | 1 3/4 | 2.687 | 51.10 |
| UM763 | 22-058 | 1 13/16 | 2.750 | 54.80 |
| UM764 | 22-060 | 1 7/8 | 2.875 | 59.10 |
| UM765 | 22-062 | 1 15/16 | 2.875 | 63.40 |
| UM766 | 22-064 | 2 | 2.937 | 71.20 |
| UM767 | 22-066 | 2 1/16 | 3.062 | 71.20 |
| UM768 | 22-068 | 2 1/8 | 3.125 | 82.90 |
| UM769 | 22-070 | 2 3/16 | 3.125 | 87.80 |
| UM770 | 22-072 | 2 1/4 | 3.250 | 89.50 |
| UM771 | 22-074 | 2 5/16 | 3.312 | 89.70 |
| UM772 | 22-076 | 2 3/8 | 3.312 | 116.00 |
| UM773 | 22-078 | 2 7/16 | 3.500 | 116.00 |
| UM774 | 22-080 | 2 1/2 | 3.500 | 135.00 |
| UM775 | 22-082 | 2 9/16 | 3.500 | 143.00 |
| UM776 | 22-084 | 2 5/8 | 3.687 | 149.00 |
| UM777 | 22-086 | 2 11/16 | 3.687 | 146.00 |
| UM778 | 22-088 | 2 3/4 | 3.687 | 158.00 |
| UM779 | 22-090 | 2 13/16 | 3.875 | 167.00 |
| UM780 | 22-092 | 2 7/8 | 3.937 | 173.00 |
| UM781 | 22-094 | 2 15/16 | 3.937 | 191.00 |
| UM782 | 22-096 | 3 | 4.062 | 192.00 |
| UM783 | 22-100 | 3 1/8 | 4.125 | 225.00 |
| UM784 | 22-104 | 3 1/4 | 4.125 | 225.00 |

*Can be used for removal of Budd Wheels.

1" DRIVE DEEP LENGTH 6-POINT



| Model No. | Mfg. No. | Size" | Overall Length" | Price /Each |
|-----------|----------|---------|-----------------|-------------|
| UM788 | 22-228 | 7/8 | 3.250 | 46.80 |
| UM789 | 22-230 | 15/16 | 3.250 | 46.80 |
| UM790 | 22-232 | 1 | 3.250 | 46.80 |
| UM791 | 22-234 | 1 1/16 | 3.250 | 46.80 |
| UM792 | 22-236 | 1 1/8 | 3.250 | 47.90 |
| UM793 | 22-238 | 1 3/16 | 3.250 | 49.20 |
| UM794 | 22-240 | 1 1/4 | 3.250 | 49.90 |
| UM795 | 22-242 | 1 5/16 | 3.500 | 51.70 |
| UM796 | 22-244 | 1 3/8 | 3.500 | 52.30 |
| UM797 | 22-246 | 1 7/16 | 3.500 | 59.30 |
| UM798 | 22-248* | 1 1/2 | 3.500 | 61.40 |
| UM799 | 22-250 | 1 9/16 | 3.500 | 69.90 |
| UM800 | 22-252 | 1 5/8 | 3.500 | 69.90 |
| UM801 | 22-254 | 1 11/16 | 3.750 | 74.40 |
| UM802 | 22-256* | 1 3/4 | 3.750 | 77.10 |
| UM803 | 22-258 | 1 13/16 | 3.750 | 81.20 |
| UM804 | 22-260 | 1 7/8 | 4.000 | 85.10 |
| UM805 | 22-262 | 1 15/16 | 4.000 | 95.80 |
| UM806 | 22-264 | 2 | 4.000 | 108.00 |
| UM807 | 22-266 | 2 1/16 | 4.250 | 112.00 |
| UM808 | 22-268 | 2 1/8 | 4.250 | 112.00 |
| UM809 | 22-270 | 2 3/16 | 4.250 | 126.00 |
| UM810 | 22-272 | 2 1/4 | 4.500 | 122.00 |

*Can be used for removal of budd wheels.

1" DRIVE ADAPTERS



| Model No. | Mfg. No. | Overall Length" | Size" | Price /Each |
|-----------|----------|-----------------|---------------|-------------|
| UM823 | 22-951 | 3.000 | 1 F x 3/4 M | 49.10 |
| UM824 | 22-952 | 3.563 | 1 F x 1 1/2 M | 92.60 |

1" DRIVE EXTENSIONS



| Model No. | Mfg. No. | Length" | Price /Each |
|-----------|----------|---------|-------------|
| UM820 | 22-923 | 7.000 | 95.80 |
| UM821 | 22-925 | 13.000 | 129.00 |

1" DRIVE UNIVERSAL JOINTS



| Model No. | Mfg. No. | Overall Length" | Rotation | Price /Each |
|-----------|----------|-----------------|----------|-------------|
| UM822 | 22-947 | 4.438 | 25° | 169.00 |

1" DRIVE O-RINGS & RETAINER PINS

- Can be used for removal of Budd Wheels

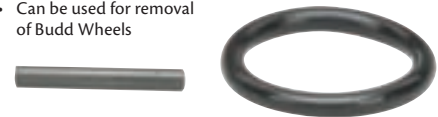

| Model No. | Mfg. No. | Description | Price /Each |
|-----------|----------|-------------------------|-------------|
| UM826 | 22-962 | 1 3/4" Dia. O-Ring | 4.28 |
| UM827 | 22-963 | 1 7/8" Lg. Retainer Pin | 2.34 |

BLACK OXIDE RATCHETS



| Model No. | Mfg. No. | Overall Length" | Head Width" | Head Depth" | No. of Teeth | Price /Each |
|---------------------|----------|-----------------|-------------|-------------|--------------|-------------|
| 3/4" DRIVE | | | | | | |
| TDR301 | 21-972 | 19 | 2.50 | 2.00 | 24 | 156.00 |
| 1" DRIVE | | | | | | |
| UM819 | 22-906 | 30 | 3.750 | 1.375 | 24 | 324.00 |
| 1 1/2" DRIVE | | | | | | |
| UM863 | 23-906 | 30 | 3.750 | 1.375 | 24 | 537.00 |



7-PC. 6-POINT 3/8" DRIVE UNIVERSAL IMPACT SOCKET SETS

- Includes socket bar **UM500** and (7) socket clips **UM505**
- Approximate weight, 1.00 lb.
- Includes the following sizes: 3/8", 7/16", 1/2", 9/16", 5/8", 11/16", 3/4"

Model No. TDR252
Mfg. No. 19-894
Price/Each \$259.00



8-PC. 6-POINT 1/2" DRIVE DEEP IMPACT SOCKET SETS

- Includes socket bar **UM500**, and (8) socket clips **UM506**
- Approximate weight, 5.09 lbs.
- Includes the following sizes: 1/2", 9/16", 5/8", 11/16", 3/4", 13/16", 7/8", 15/16"

Model No. UM709
Mfg. No. 20-897
Price/Each \$128.00



9-PC. 6-POINT 3/8" DRIVE IMPACT SOCKET SETS

- Includes socket bar **UM500** and (10) socket clips **UM505**
- Approximate weight, 1.00 lb.
- Includes the following sizes: 1/4", 5/16", 3/8", 7/16", 1/2", 9/16", 5/8", 11/16", 3/4"

Model No. TDR353
Mfg. No. 19-890
Price/Each \$69.40



9-PC. 6-POINT 3/8" DRIVE DEEP IMPACT SOCKET SETS

- Includes socket bar **UM500** and (9) socket clips **UM505**
- Approximate weight, 1.25 lbs.
- Includes the following sizes: 1/4", 5/16", 3/8", 7/16", 1/2", 9/16", 5/8", 11/16", 3/4"

Model No. TDR344
Mfg. No. 19-895
Price/Each \$88.30



9-PC. 6-POINT 1/2" DRIVE UNIVERSAL IMPACT SOCKET SETS

- Includes socket bar **UM502** and (9) socket clips **UM506**
- Approximate weight, 4.00 lbs.
- Includes the following sizes: 1/2", 9/16", 5/8", 11/16", 3/4", 13/16", 7/8", 15/16", 1"

Model No. TDR241
Mfg. No. 20-899
Price/Each \$375.00



11-PC. 6-POINT 1/2" DRIVE IMPACT SOCKET SETS

- Includes socket bar **UM503**, and (20) socket clips **UM506**
- Approximate weight, 4.32 lbs.
- Includes the following sizes: 1/2", 9/16", 5/8", 11/16", 3/4", 13/16", 7/8", 15/16", 1", 1 1/16", 1 1/8"

Model No. T1812
Mfg. No. 20-893
Price/Each \$139.00

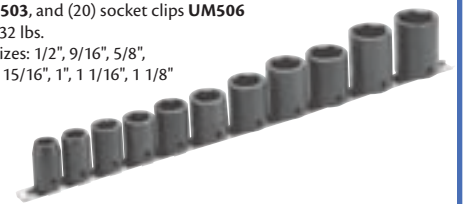

11-PC. 6-POINT 3/8" DRIVE IMPACT SOCKET SETS - METRIC

- Includes socket bar **UM500** and (20) socket clips **UM505**
- Approximate weight, 1.25 lbs.
- Set contains sockets from 7 mm to 17 mm

Model No. TDR337
Mfg. No. 46-890
Price/Each \$92.60



14-PC. 6-POINT 1/2" DRIVE IMPACT SOCKET SETS - METRIC

- Includes socket bar **UM502** and (20) socket clips **UM506**
- Approximate weight, 3.77 lbs.
- Set contains sockets from 10 mm to 24 mm

Model No. T1813
Mfg. No. 47-893
Price/Each \$154.00



11-PC. 6-POINT 3/8" DRIVE DEEP IMPACT SOCKET SETS - METRIC

- Includes socket bar **UM500** and (20) socket clips **UM505**
- Approximate weight, 1.80 lbs.
- Set contains sockets from 7 mm to 17 mm

Model No. TDR332
Mfg. No. 46-898
Price/Each \$118.00



14-PC. 6-POINT 1/2" DRIVE DEEP IMPACT SOCKET SETS - METRIC

- Includes socket bar **UM503** and (20) socket clips **UM506**
- Approximate weight, 7.89 lbs.
- Set contains sockets from 10 mm to 24 mm

Model No. UN777
Mfg. No. 47-897
Price/Each \$238.00



14-PC. 6-POINT 3/4" DRIVE IMPACT SOCKET SETS

- Includes (2) socket bars **UM503** and (20) socket clips **UM507**
- Approximate weight, 16.25 lbs.
- Includes the following sizes: 3/4", 13/16", 7/8", 15/16", 1", 1 1/16", 1 1/8", 1 3/16", 1 1/4", 1 5/16", 1 3/8", 1 7/16", 1 1/2", 1 5/8"

Model No. UM730
Mfg. No. 21-893
Price/Each \$333.00



12-PC. 6-POINT 3/4" DRIVE IMPACT SOCKET SETS - METRIC

- Includes 2 socket bars **UM502** and (20) socket clips **UM507**
- Approximate weight, 13.6 lbs.
- Includes the following sizes: 19 mm, 20 mm, 21mm, 22 mm, 23 mm, 24 mm, 27mm, 30 mm, 32 mm, 36 mm, 41mm, 46 mm

Model No. UN783
Mfg. No. 48-893
Price/Each \$348.00



IMPACT SOCKET SETS



IMPACT STANDARD SOCKET SETS 1/2" DRIVE

- Chrome molybdenum alloy steel (CR-MO) for exceptional strength and long lasting durability
- High visibility laser-etched markings
- Reinforced molded case with sizes marked for quick identification and storage
- 6-point sockets



GEARWRENCH

| Model No. | Mfg. No. | No. of Pieces | Description | Price /Each |
|-----------|----------|---------------|----------------------|-------------|
| TLV393 | 84932N | 19 | SAE 3/8" to 1 1/2" | 105.00 |
| TLV394 | 84933N | 25 | Metric 8 mm to 36 mm | 121.00 |

IMPACT DEEP SOCKET SETS, 1/2" DRIVE

- Chrome molybdenum alloy steel (CR-MO) for exceptional strength and long lasting durability
- High visibility laser-etched markings
- Reinforced molded case with sizes marked for quick identification and storage
- 6-point sockets



GEARWRENCH

| Model No. | Mfg. No. | No. of Pieces | Description | Price /Each |
|-----------|----------|---------------|----------------------|-------------|
| TLV397 | 84934N | 19 | SAE 3/8" to 1 1/2" | 178.00 |
| TLV398 | 84935N | 29 | Metric 8 mm to 36 mm | 243.00 |

12-PC. IMPACT STANDARD SOCKET SETS, 1/2" DRIVE

- Chrome molybdenum alloy steel (CR-MO) for exceptional strength and long lasting durability
- High visibility laser-etched markings
- Reinforced molded case with sizes marked for quick identification and storage
- 6-point sockets



GEARWRENCH

| Model No. | Mfg. No. | Description | Price /Each |
|-----------|----------|----------------------|-------------|
| TLV391 | 84931N | SAE 3/8" to 1 1/16" | 51.20 |
| TLV392 | 84930N | Metric 8 mm to 19 mm | 51.50 |

12-PC. IMPACT DEEP SOCKET SETS, 1/2" DRIVE

- Chrome molybdenum alloy steel (CR-MO) for exceptional strength and long lasting durability
- High visibility laser-etched markings
- Reinforced molded case with sizes marked for quick identification and storage
- 6-point sockets



GEARWRENCH

| Model No. | Mfg. No. | Description | Price /Each |
|-----------|----------|----------------------|-------------|
| TLV395 | 84942N | SAE 3/8" to 1 1/16" | 88.80 |
| TLV396 | 84944 | Metric 8 mm to 19 mm | 98.30 |

13-PC. IMPACT UNIVERSAL SOCKET SETS, 1/2" DRIVE

- Chrome molybdenum alloy steel (CR-MO) for exceptional strength and long lasting durability
- High visibility laser-etched markings
- Reinforced molded case with sizes marked for quick identification and storage
- 6-point sockets



GEARWRENCH

| Model No. | Mfg. No. | Description | Price /Each |
|-----------|----------|-----------------------|-------------|
| TLV399 | 84938N | SAE 1/2" to 1 1/4" | 239.00 |
| TLV400 | 84939N | Metric 10 mm to 24 mm | 205.00 |

44-PC. IMPACT SAE/ METRIC STANDARD & DEEP SOCKET SETS, 3/8" DRIVE

- Chrome molybdenum alloy steel (CR-MO) for exceptional strength and long lasting durability
- High visibility laser-etched markings
- Reinforced molded case with sizes marked for quick identification and storage

INCLUDES:

- 6-point 5/16" to 3/4" standard and deep sockets
- 6-point 8 mm to 19 mm standard and deep sockets, and a 21 mm deep socket
- 3 extensions (3", 6" and 10")

Model No. TLV390
Mfg. No. 84916N
Price/Each \$135.00

GEARWRENCH



1/4" DRIVE POWER SOCKETS 6-POINT

For self-tapping screws



| Model No. | Mfg. No. | Size" | Overall Length" | Price /Each |
|-----------------|----------|-------|-----------------|-------------|
| MAGNETIC | | | | |
| UM552 | 18-078 | 1/4 | 0.88 | 17.80 |
| UM554 | 18-080 | 5/16 | 1 | 18.50 |
| UM555 | 18-081 | 11/32 | 1 | 18.30 |
| UM556 | 18-082 | 3/8 | 1 | 15.00 |
| UM557 | 18-084 | 7/16 | 1 | 18.30 |
| UM558 | 18-086 | 1/2 | 1 | 19.20 |

1/4" DRIVE POWER SOCKETS THIN WALL 6-POINT

Suitable for hand use, or limited-clearance power applications only



| Model No. | Mfg. No. | Size" | Overall Length" | Price /Each |
|-----------|----------|-------|-----------------|-------------|
| UM534 | 18-006 | 3/16 | 0.820 | 7.13 |
| UM536 | 18-008 | 1/4 | 0.820a | 7.13 |
| UM537 | 18-009 | 9/32 | 0.820 | 7.15 |
| UM538 | 18-010 | 5/16 | 0.820 | 7.15 |
| UM539 | 18-011 | 11/32 | 0.820 | 7.15 |
| UM540 | 18-012 | 3/8 | 0.820 | 7.15 |
| UM541 | 18-014 | 7/16 | 0.820 | 7.19 |
| UM542 | 18-016 | 1/2 | 0.820 | 7.19 |

1/4" DRIVE POWER SOCKETS DEEP THIN WALL 6-POINT

Suitable for hand use, or limited-clearance power applications only



| Model No. | Mfg. No. | Size" | Overall Length" | Price /Each |
|-----------|----------|-------|-----------------|-------------|
| UM559 | 18-206 | 3/16 | 1.94 | 9.35 |
| UM560 | 18-208 | 1/4 | 1.94 | 9.33 |
| UM561 | 18-209 | 9/32 | 1.94 | 9.35 |
| UM562 | 18-210 | 5/16 | 1.94 | 9.37 |
| UM563 | 18-211 | 11/32 | 1.94 | 9.37 |
| UM564 | 18-212 | 3/8 | 1.94 | 9.37 |
| UM565 | 18-214 | 7/16 | 1.94 | 9.42 |
| UM566 | 18-216 | 1/2 | 1.94 | 9.45 |

1/4" DRIVE POWER EXTENSIONS



| Model No. | Mfg. No. | Overall Length" | Price /Each |
|-----------|----------|-----------------|-------------|
| UM567 | 18-921 | 2 | 8.78 |
| UM568 | 18-923 | 6 | 12.20 |



NOTE:
POWER SOCKETS ARE NOT FOR USE WITH IMPACT TOOLS

1 1/2" DRIVE SOCKETS 6-POINT



| Model No. | Mfg. No. | Size" | Overall Length" | Price /Each |
|-----------|----------|---------|-----------------|-------------|
| UM830 | 23-044 | 1 3/8 | 3.125 | 129.00 |
| UM831 | 23-046 | 1 7/16 | 3.125 | 135.00 |
| UM832 | 23-048 | 1 1/2 | 3.125 | 135.00 |
| UM833 | 23-052 | 1 5/8 | 3.125 | 138.00 |
| UM834 | 23-054 | 1 11/16 | 3.13 | 138.00 |
| UM835 | 23-058 | 1 13/16 | 3.31 | 148.00 |
| UM836 | 23-060 | 1 7/8 | 3.50 | 148.00 |
| UM837 | 23-064 | 2 | 3.63 | 148.00 |
| UM838 | 23-066 | 2 1/16 | 3.63 | 148.00 |
| UM839 | 23-068 | 2 1/8 | 3.63 | 148.00 |
| UM840 | 23-070 | 2 3/16 | 3.63 | 148.00 |
| UM841 | 23-072 | 2 1/4 | 3.94 | 166.00 |
| UM842 | 23-076 | 2 3/8 | 4.125 | 198.00 |
| UM843 | 23-078 | 2 7/16 | 4.125 | 198.00 |
| UM844 | 23-080 | 2 1/2 | 4.13 | 199.00 |
| UM845 | 23-082 | 2 9/16 | 4.13 | 209.00 |
| UM846 | 23-084 | 2 5/8 | 4.250 | 216.00 |
| UM847 | 23-088 | 2 3/4 | 4.375 | 249.00 |
| UM849 | 23-094 | 2 15/16 | 4.500 | 282.00 |
| UM850 | 23-096 | 3 | 4.625 | 308.00 |
| UM851 | 23-100 | 3 1/8 | 4.625 | 345.00 |
| UM852 | 23-108 | 3 3/8 | 4.625 | 356.00 |
| UM853 | 23-112 | 3 1/2 | 5.00 | 369.00 |
| UM854 | 23-116 | 3 5/8 | 5.13 | 486.00 |
| UM855 | 23-120 | 3 3/4 | 5.25 | 552.00 |
| UM857 | 23-128 | 4 | 5.48 | 663.00 |
| UM858 | 23-132 | 4 1/8 | 5.53 | 696.00 |
| UM859 | 23-136 | 4 1/4 | 5.60 | 712.00 |
| UM862 | 23-160 | 5 | 7.00 | 1351.00 |

1 1/2" DRIVE O-RINGS & RETAINER PINS



| Model No. | Mfg. No. | Description | Price /Each |
|-----------|----------|-------------------------|-------------|
| UM868 | 23-962 | 2 7/8" Dia. O-Ring | 5.11 |
| UM869 | 23-963 | 2 7/8" Lg. Retainer Pin | 3.77 |

1 1/2" DRIVE EXTENSIONS



| Model No. | Mfg. No. | Overall Length" | Price /Each |
|-----------|----------|-----------------|-------------|
| UM864 | 23-924 | 8.000 | 358.00 |
| UM865 | 23-928 | 15.000 | 396.00 |



GET CLEAN

Industrial handsoap with scrubbing particles for stubborn grease and grime
TRY SOME TODAY!

Model JG223
See page 327



TORQUE WRENCHES

DIAL TORQUE WRENCHES

Dial torque wrenches are accurate within $\pm 4\%$ of indicated value between 20% and 100% of the range. These units provide readings in both clockwise and counterclockwise directions. Oversized dial allows for easy quick reading and memory needle permits the user to check the highest torque level achieved. Several units listed below are equipped with an indicator light that can be set to illuminate along with a buzzer that will sound when desired torque level is achieved.



ARMSTRONG
INDUSTRIAL HAND TOOLS

| Model No. | Mfg. No. | By Range | | By Graduations | | Drive Size" | Length" | Wt. lbs. | Price /Each |
|-----------|----------|----------------|----------|----------------|---------|-------------|---------|----------|-------------|
| U0044 | 64-302 | 0-75 in.-lbs. | 0-8 Nm | 1 in.-lbs. | 0.2 Nm | 1/4 | 10.25 | 1.2 | 299.00 |
| U0045 | 64-352 | 0-250 in.-lbs. | 0-27 Nm | 5 in.-lbs. | 0.5 Nm | 3/8 | 10.25 | 1.3 | 310.00 |
| U0046 | 64-355 | 0-600 in.-lbs. | 0-66 Nm | 20 in.-lbs. | 2.0 Nm | 3/8 | 12.50 | 1.3 | 321.00 |
| U0047 | 64-358 | 0-50 ft.-lbs. | 0-66 Nm | 1 ft.-lbs. | 2.0 Nm | 3/8 | 12.50 | 1.3 | 310.00 |
| U0048 | 64-402 | 0-175 ft.-lbs. | 0-225 Nm | 5 ft.-lbs. | 5.0 Nm | 1/2 | 21 | 2.9 | 356.00 |
| U0049 | 64-405 | 0-250 ft.-lbs. | 0-330 Nm | 5 ft.-lbs. | 10.0 Nm | 1/2 | 21 | 2.9 | 361.00 |
| U0050 | 64-407 | 0-250 ft.-lbs. | 0-330 Nm | 5 ft.-lbs. | 10.0 Nm | 1/2* | 23.30 | 3.5 | 369.00 |
| U0051 | 64-452 | 0-350 ft.-lbs. | 0-450 Nm | 10 ft.-lbs. | 10.0 Nm | 3/4 | 47 | 8.3 | 712.00 |
| U0052 | 64-455 | 0-600 ft.-lbs. | 0-800 Nm | 10 ft.-lbs. | 20.0 Nm | 3/4 | 47** | 8.3 | 821.00 |

DIAL TORQUE WRENCHES WITH ADJUSTABLE TORQUE INDICATOR LIGHT

| | | | | | | | | | |
|-------|--------|-----------------|-----------|-------------|---------|-----|--------|------|---------|
| U0053 | 64-458 | 0-600 ft.-lbs. | 0-800 Nm | 10 ft.-lbs. | 20.0 Nm | 3/4 | 47** | 8.3 | 873.00 |
| U0054 | 64-502 | 0-1000 ft.-lbs. | 0-1325 Nm | 20 ft.-lbs. | 25.0 Nm | 1 | 72** | 17.8 | 1532.00 |
| U0055 | 64-505 | 0-2000 ft.-lbs. | 0-2650 Nm | 50 ft.-lbs. | 50.0 Nm | 1 | 111*** | 42 | 3156.00 |

* Indicates ratchet head, ** Indicates extension handle included, *** Indicates 4 extension handles included

MICROMETER TORQUE WRENCHES

Micrometer adjustable "Clicker" torque wrenches emit an audible click and an impulse when torque setting has been reached. Once the pressure is relieved, the wrench resets itself. Tools are calibrated in the right hand direction only, left hand calibration is available upon special request. Accuracy is $\pm 3\%$ between 20% and 100% of the range. A factory calibration tape is supplied with each wrench. Re-calibration is done externally so there is no need to disassemble the wrench. All wrenches come with a carrying case.



ARMSTRONG
INDUSTRIAL HAND TOOLS

| Model No. | Mfg. No. | By Range | | By Graduations | | Drive Size" | Length" | Wt. lbs. | Price /Each |
|-----------|----------|-------------------|--------------|----------------|---------|-------------|---------|----------|-------------|
| U0024 | 64-031 | 5-50 in.-lbs. | 0.58-6.21 Nm | 1 in.-lbs. | 0.11 Nm | 1/4 | 8.0 | 0.71 | 259.00 |
| U0025 | 64-032 | 30-200 in.-lbs. | 4-23 Nm | 1 in.-lbs. | 0.11 Nm | 1/4 | 9.5 | 0.76 | 252.00 |
| U0026 | 64-038 | - | 4-25 Nm | - | 0.1 Nm | 1/4 | 9.5 | 0.76 | 272.00 |
| U0027 | 64-041 | 50-250 in.-lbs. | 6-29 Nm | 1 in.-lbs. | 0.11 Nm | 3/8 | 9.5 | 0.76 | 257.00 |
| U0028 | 64-042 | 100-1000 in.-lbs. | 14-116 Nm | 5 in.-lbs. | 0.6 Nm | 3/8 | 17.1 | 2.05 | 274.00 |
| U0029 | 64-046 | 10-100 ft.-lbs. | 17-139 Nm | 0.5 ft.-lbs. | 0.7 Nm | 3/8 | 17.1 | 2.05 | 269.00 |
| U0030 | 64-049 | - | 10-100 Nm | - | 1.0 Nm | 3/8 | 17.1 | 2.05 | 261.00 |
| U0031 | 64-081 | 240-1800 in.-lbs. | 34-210 Nm | 12 in.-lbs. | 1.4 Nm | 1/2 | 20.5 | 2.45 | 299.00 |
| U0032 | 64-082 | 300-3000 in.-lbs. | 43-348 Nm | 18 in.-lbs. | 2.03 Nm | 1/2 | 20.5 | 2.45 | 312.00 |
| U0033 | 64-084 | 10-100 ft.-lbs. | 17-139 Nm | 0.5 ft.-lbs. | 0.7 Nm | 1/2 | 17.1 | 2.05 | 282.00 |
| U0034 | 64-084 | 10-150 ft.-lbs. | 20-210 Nm | 1 ft.-lbs. | 1.4 Nm | 1/2 | 20.5 | 2.45 | 294.00 |
| U0035 | 64-086 | 25-250 ft.-lbs. | 43-348 Nm | 1 ft.-lbs. | 1.4 Nm | 1/2 | 24 | 2.45 | 328.00 |
| U0036 | 64-089 | - | 40-340 Nm | - | 2.0 Nm | 1/2 | 24 | 2.45 | 315.00 |
| U0037 | 64-094 | 50-400 ft.-lbs. | 85-559 Nm | 2.5 ft.-lbs. | 3.4 Nm | 3/4 | 33.0 | 9.62 | 861.00 |
| U0038 | 64-095 | 100-600 ft.-lbs. | 153-830 Nm | 2.5 ft.-lbs. | 3.4 Nm | 3/4 | 40.5 | 10.72 | 1269.00 |
| U0039 | 64-099 | - | 150-800 Nm | - | 2.5 Nm | 3/4 | 40.5 | 10.72 | 1210.00 |

REACTION BAR TORQUE MULTIPLIERS

- Can easily be applied by one person using 1/2" drive tools
- Planetary gear system provides output accuracy of $\pm 5\%$
- Square output drive shears at 3-10% overload to protect expensive internal components from damage
- Anti-backlash input torque holding ratchet device



UG971

ARMSTRONG
INDUSTRIAL HAND TOOLS

| Model No. | Mfg. No. | Output Drive" | Max. Input | Max. Output | Torque Ratio | Overall Length" | Price /Each |
|-----------|----------|---------------|--------------|---------------|--------------|-----------------|-------------|
| UG970 | 64-830 | 3/4 | 227 ft.-lbs. | 750 ft.-lbs. | 3.3:1 | 8.53 | 754.00 |
| UG971 | 64-832 | 3/4 | 200 ft.-lbs. | 1200 ft.-lbs. | 6.0:1 | 14.13 | 1553.00 |
| UG972 | 64-834 | 1 | 162 ft.-lbs. | 2200 ft.-lbs. | 13.6:1 | 20.0 | 2621.00 |
| UG973 | 64-836 | 1 | 173 ft.-lbs. | 3200 ft.-lbs. | 18.5:1 | 20.0 | 3465.00 |

BEAM TORQUE WRENCH

- Scale includes both SAE (In/Lb, Ft/Lb) and Metric (Nm)
- Serviceable by bending pointer to zero before use
- Palm-fit handle pivots on beam to maintain constant distance from drive point to load point for precise measurement
- Directly measure a variety of torque values when tightening fasteners
- Pointer moves clockwise or counter-clockwise (+/-7%) to measure torque



TDS979

GEARWRENCH

| Model No. | Mfg. No. | Overall Length" | Drive Size" | Torque Range | Increments | Tool Weight lbs. | Price /Each |
|-----------|----------|-----------------|-------------|----------------|--------------|------------------|-------------|
| TDS979 | 2955D | 11 | 1/4 | 0-60 in.-lbs. | 2.5 in.-lbs. | 0.85 | 61.20 |
| TDS941 | 2956D | 16 | 3/8 | 0-600 in.-lbs. | 50 in.-lbs. | 1.45 | 82.10 |
| TDS949 | 2957N | 20 | 1/2 | 0-150 ft.-lbs. | 5 ft.-lbs. | 1.89 | 76.20 |

MICROMETER TORQUE WRENCHES

- Pliable, elastomer handle grip for superior comfort and oil resistance
- Accurate in clockwise direction +/- 3% in upper 80% of the range
- Micrometer twist lock ring provides secure locking mechanism
- Sealed tear-drop head provides access and strength and keeps out contaminants



TLV411

GEARWRENCH

| Model No. | Mfg. No. | Drive" | Torque Range | Price /Each |
|-----------|----------|--------|-----------------|-------------|
| TLV411 | 85060 | 1/4 | 30-200 in.-lbs. | 145.00 |
| TLV412 | 85061 | 3/8 | 25-250 in.-lbs. | 137.00 |
| TLV413 | 85062 | 3/8 | 10-100 ft.-lbs. | 158.00 |
| TLV414 | 85066 | 1/2 | 30-250 ft.-lbs. | 178.00 |

TORQUE LIMITING SCREWDRIVER

- Highly durable and easy to use
- Aluminum housings reduces weight and maximizes durability
- Smooth, accurate and consistent performance when tightening fasteners
- Roller bearing cam mechanism automatically slips to prevent over-tightening when maximum torque setting is achieved
- Easy-release bit holder securely retains bits during in operation while permitting easy removal
- Spring-loaded locking collar locks the scale at the desired torque setting
- Ideal for precision electronics assembly and other light screw assembly applications
- Working parts are heat treated for added strength and durability
- Meets or exceeds ASME B107.14M and ISO 6789 specifications
- Accuracy: +/- 6% clockwise
- Length: 6-1/2"
- Handle type: Steel

TYO342



| Model No. | Mfg. No. | Torque Range | Drive Size" | Increments | Tool Weight oz. | Price /Each |
|-----------|----------|--------------|-------------|------------|-----------------|-------------|
| TYO342 | TS-100 | 20-200 in-oz | 1/4 Hex | 2 in-oz. | 8 | 325.00 |
| TYO343 | TS-30 | 6-30 in-lbs. | 1/4 Hex | 1 in-lbs. | 8 | 325.00 |
| TYO344 | TS-35 | 6-36 in-lbs. | 1/4 Hex | 1 in-oz. | 8 | 325.00 |
| TYO345 | TS-3M | 0.7-3.5 Nm | 1/4 Hex | 0.1 Nm | 8 | 337.00 |

TORQUE LIMITING SCREWDRIVER KIT

Kit Includes

- 1 Miniature Adjustable Torque Limiting Screwdriver, 5-20 in-oz. (TYO346)
- 1 Miniature Torque Screwdriver Blade .040"
- 1 Miniature Torque Screwdriver Blade .055"
- 1 Miniature Torque Screwdriver Blade .070"
- 1 Miniature Torque Screwdriver Blade .080"
- 1 Miniature Torque Screwdriver Blade .100"
- 1 Miniature Phillips Screwdriver Sz. 0, 1
- 1 Miniature Phillips Screwdriver Sz. 2, 3, 4
- 1 Miniature Spline Key Size .048" - 4 Flutes
- 1 Miniature Spline Key Size .048" - 6 Flutes
- 1 Miniature Spline Key Size .060" - 6 Flutes
- 1 Miniature Spline Key Size .069" - 6 Flutes
- 1 Miniature Spline Key Size .072" - 6 Flutes
- 1 Miniature Spline Key Size .076" - 4 Flutes
- 1 Miniature Spline Key Size .096" - 6 Flutes
- 2 Miniature Bit Holder Universal Torque
- 1 Miniature Hex Socket 5/64"
- 1 Miniature Hex Socket 3/32"
- 1 Miniature Hex Socket 7/64"
- 1 Miniature Hex Socket 1/8"
- 1 Miniature Hex Socket 5/32"
- 1 Miniature Hex Key .028"
- 1 Miniature Hex Key .035"
- 1 Miniature Hex Key .050"
- 1 Miniature Hex Key 1/16"
- 1 Miniature Hex Key 5/64"
- 1 Case
- 1 Insert

TYO347



Model No. TYO347
Mfg. No. KTT-1
Price/Each \$807.00

MINIATURE ADJUSTABLE TORQUE LIMITING SCREWDRIVER

- Accuracy: +/-6% Clockwise
- Length: 3-5/8"

TYO346



| Model No. | Mfg. No. | Torque Range | Drive Size" | Increments | Tool Weight oz. | Price /Each |
|-----------|----------|--------------|-------------|------------|-----------------|-------------|
| TYO346 | TT-1 | 5-20 in-oz. | Universal | 1/4 in-oz. | 0.96 | 525.00 |

TORQUE SCREWDRIVER SET

- Compact, easy to use set includes the Torque Screwdriver, a 6-piece bit set and a rugged blow-molded case with foam inserts for a tight, organized fit
- Increased usability and readability plus a wider torque range
- Tri-lobular design with a textured finish for better grip
- Lightweight, aluminum frame
- N.I.S.T. traceable calibration certificate
- Bits Included: Six 3-1/2" power drivers: Phillips #1 and #2; Slotted 3/16" and 1/4"; and Square #1 and #2
- Made in the USA



| Model No. | Mfg. No. | Torque Range | Length" | Handle Type | Price /Each |
|-----------|----------|--------------|---------|-------------|-------------|
| TYO550 | 57032 | 5-40 in-lbs. | 5 | Plastic | 439.00 |

ELECTRONIC TORQUE TESTER

- Torque testers are used to check the accuracy of various types of torque wrenches and screwdrivers including pre-sets
- Designed to be mounted on a workbench or wall allowing operators to test wrenches in a lab or at their work stations; adjustable display allows viewing at any angle
- Features three modes of operation: 1) track mode (displays/tracks torque as it is being applied), 2) peak hold (holds the highest torque value), and 3) first peak (measures the value when micrometer click-style wrenches click; verifies wrench accuracy)
- Three way led yellow, green, red indicator lights with audible buzzer indicate under target (yellow), at/within target tolerance (green), and over target/tolerance (red)
- Not for use with power or impact tools
- Female-to-female square drive adapter is included
- Includes "certificate of calibration". Certification is the documentation of the actual calibration of the torque tester to include; model number, serial number, date, actual readings, type of test equipment, and test equipment calibration standards
- Torque Accuracy +/-1% (20-100% of Full Range)



| Model No. | Mfg. No. | Torque Range | Reading | Drive Tang Size" | Price /Each |
|-----------|----------|----------------|---------|------------------|-------------|
| TSB245 | 64-623 | 5-50 in-lbs. | Digital | 1/4 | 1749.00 |
| TSB247 | 64-637 | 10-100 ft-lbs. | Digital | 3/8 | 1799.00 |
| TSB248 | 64-647 | 25-250 in-lbs. | Digital | 1/2 | 1699.00 |
| TSB249 | 64-657 | 60-600 ft-lbs. | Digital | 3/4 | 1768.00 |

WRENCHES

ADJUSTABLE HOOK SPANNER WRENCHES



| Model No. | Mfg. No. | Capacity Range for Dia." | Thickness" | Hook Specifications Depth" | Length" | Price /Each |
|-----------|----------|--------------------------|------------|----------------------------|---------|-------------|
| UN498 | 34-301 | 3/4 - 2 | 0.34375 | 0.125 | 6 3/8 | 46.80 |
| UN499 | 34-305 | 1 1/4 - 3 | 13/32 | 0.15625 | 8 1/8 | 53.20 |
| UN500 | 34-307 | 2 - 4 3/4 | 15/32 | 0.1875 | 11 3/8 | 74.30 |
| UN501 | 34-310 | 4 1/2 - 6 1/4 | 15/32 | 0.25 | 12 1/8 | 77.70 |
| UN502 | 34-313 | 6 1/8 - 8 3/4 | 15/32 | 0.3125 | 13 3/4 | 94.80 |

ADJUSTABLE PIN SPANNER WRENCHES



| Model No. | Mfg. No. | Capacity Range for Dia." | Hook Thickness" | Pin Specifications Dia." | Height" | Length" | Price /Each |
|-----------|----------|--------------------------|-----------------|--------------------------|---------|---------|-------------|
| UN503 | 34-351 | 3/4 - 2 | 0.34375 | 0.125 | 0.125 | 6.375 | 49.30 |
| UN504 | 34-354 | 3/4 - 2 | 0.34375 | 0.1875 | 0.15625 | 6.375 | 52.90 |
| UN505 | 34-358 | 1 1/4 - 3 | 0.40625 | 0.1875 | 0.1875 | 8.125 | 56.90 |
| UN506 | 34-361 | 1 1/4 - 3 | 0.40625 | 0.25 | 0.21875 | 8.125 | 57.70 |
| UN507 | 34-363 | 2 - 4 3/4 | 0.46875 | 0.25 | 0.25 | 11.375 | 79.90 |
| UN508 | 34-366 | 4 1/2 - 6 1/4 | 0.46875 | 0.375 | 0.25 | 12.375 | 84.20 |

PIN SPANNER WRENCHES



| Model No. | Mfg. No. | For Circle Dia." | Pin Specifications Dia." | Height" | Length" | Price /Each |
|-----------|----------|------------------|--------------------------|---------|---------|-------------|
| UN483 | 34-201 | 1 | 3/16 | 5/32 | 4 | 15.60 |
| UN484 | 34-204 | 1 1/4 | 13/64 | 5/32 | 4 1/2 | 16.80 |
| UN485 | 34-207 | 1 1/2 | 7/32 | 3/16 | 5 | 16.90 |
| UN486 | 34-210 | 1 3/4 | 15/64 | 3/16 | 5 1/2 | 17.30 |
| UN487 | 34-213 | 2 | 1/4 | 7/32 | 6 | 19.70 |
| UN488 | 34-216 | 2 1/4 | 17/64 | 1/4 | 6 1/2 | 20.40 |
| UN489 | 34-219 | 2 1/2 | 9/32 | 9/32 | 7 | 20.50 |
| UN490 | 34-222 | 2 3/4 | 19/64 | 9/32 | 7 1/2 | 21.80 |
| UN491 | 34-225 | 3 | 5/16 | 9/32 | 8 | 23.70 |
| UN492 | 34-228 | 3 1/4 | 21/64 | 9/32 | 8 1/2 | 26.10 |
| UN493 | 34-231 | 3 1/2 | 11/32 | 5/16 | 9 | 27.50 |
| UN494 | 34-234 | 3 3/4 | 23/64 | 11/32 | 9 1/2 | 29.50 |
| UN495 | 34-237 | 4 | 3/8 | 11/32 | 10 | 31.10 |
| UN496 | 34-240 | 5 | 7/16 | 13/32 | 12 | 39.70 |
| UN497 | 34-243 | 6 | 1/2 | 9/16 | 14 | 55.90 |

FACE SPANNER WRENCHES



| Model No. | Mfg. No. | Span Distance" | Pin Specifications Dia." | Height" | Length" | Price /Each |
|-----------|----------|----------------|--------------------------|---------|---------|-------------|
| UN467 | 34-101 | 1 | 3/16 | 3/16 | 4 1/2 | 17.80 |
| UN468 | 34-104 | 1 1/4 | 7/32 | 7/32 | 5 | 19.90 |
| UN469 | 34-107 | 1 1/2 | 7/32 | 7/32 | 5 1/2 | 21.50 |
| UN470 | 34-110 | 1 3/4 | 7/32 | 7/32 | 6 | 23.70 |
| UN471 | 34-113 | 2 | 1/4 | 1/4 | 6 1/2 | 26.50 |
| UN472 | 34-116 | 2 1/4 | 1/4 | 1/4 | 7 | 31.80 |
| UN473 | 34-119 | 2 1/2 | 9/32 | 9/32 | 7 1/2 | 35.70 |
| UN475 | 34-124 | 3 | 5/16 | 5/16 | 8 1/2 | 46.60 |
| UN476 | 34-127 | 3 1/4 | 5/16 | 5/16 | 9 1/8 | 53.50 |
| UN477 | 34-130 | 3 1/2 | 5/16 | 5/16 | 9 3/4 | 63.50 |
| UN478 | 34-133 | 3 3/4 | 3/8 | 3/8 | 10 3/8 | 69.40 |
| UN479 | 34-136 | 4 | 3/8 | 3/8 | 11 | 83.30 |

ADJUSTABLE CONSTRUCTION WRENCHES



Head is offset 15° from centerline, black finish.



| Model No. | Mfg. No. | Overall Length" | Capacity" | Price /Each |
|-----------|----------|-----------------|-----------|-------------|
| UN361 | 32-495 | 15 | 1.5 | 124.00 |

ADJUSTABLE FACE SPANNER WRENCHES



| Model No. | Mfg. No. | Capacity" | Extreme Dia." | Pin Specifications Height" | Length" | Price /Each |
|-----------|----------|-----------|---------------|----------------------------|---------|-------------|
| UN480 | 34-151 | 2 | 3/16 | 1/8 | 6 3/8 | 43.30 |
| UN481 | 34-154 | 3 | 1/4 | 3/16 | 8 1/4 | 59.70 |
| UN482 | 34-157 | 4 | 5/16 | 1/4 | 10-3/8 | 85.20 |

STRUCTURAL WRENCHES BLACK FINISH, 12-POINT LOBULAR OPENING



| Model No. | Mfg. No. | Opening" | Length" | Price /Each |
|-----------|----------|----------|---------|-------------|
| UN388 | 32-730 | 15/16 | 13.5 | 79.30 |
| UN390 | 32-734 | 1 1/16 | 14.75 | 83.10 |
| UN391 | 32-736 | 1 1/8 | 14.75 | 84.20 |
| UN392 | 32-740 | 1 1/4 | 17 | 92.10 |
| UN393 | 32-742 | 1 5/16 | 17 | 92.90 |
| UN394 | 32-746 | 1 7/16 | 21 | 112.00 |

| Model No. | Mfg. No. | Opening" | Length" | Price /Each |
|-----------|----------|----------|---------|-------------|
| UN395 | 32-748 | 1 1/2 | 21 | 112.00 |
| UN396 | 32-752 | 1 5/8 | 21.5 | 126.00 |
| UN397 | 32-758 | 1 13/16 | 23 | 143.00 |
| UN398 | 32-760 | 1 7/8 | 23 | 144.00 |
| UN399 | 32-764 | 2 | 24.5 | 149.00 |

STRUCTURAL WRENCHES, BLACK FINISH



| Model No. | Mfg. No. | Opening" | Length" | Price /Each |
|-----------|----------|----------|---------|-------------|
| UN362 | 32-520 | 5/8 | 12.125 | 37.10 |
| UN363 | 32-524 | 3/4 | 12.125 | 40.80 |
| UN364 | 32-528 | 7/8 | 14.5 | 55.10 |
| UN365 | 32-530 | 15/16 | 14.5 | 56.60 |
| UN366 | 32-532 | 1 | 14.5 | 55.70 |
| UN367 | 32-534 | 1 1/16 | 17 | 62.80 |
| UN368 | 32-536 | 1 1/8 | 17 | 63.90 |
| UN369 | 32-540 | 1 1/4 | 19 | 74.10 |

| Model No. | Mfg. No. | Opening" | Length" | Price /Each |
|-----------|----------|----------|---------|-------------|
| UN370 | 32-542 | 1 5/16 | 19 | 79.70 |
| UN371 | 32-546 | 1 7/16 | 21 | 98.40 |
| UN372 | 32-548 | 1 1/2 | 21 | 103.00 |
| UN373 | 32-552 | 1 5/8 | 23 | 129.00 |
| UN374 | 32-558 | 1 13/16 | 25 | 165.00 |
| UN375 | 32-560 | 1 7/8 | 25 | 169.00 |
| UN376 | 32-564 | 2 | 25 | 182.00 |

GEARED BOX WRENCHES

Speed, access, strength and safety are the most important factors when it comes to the performance of a wrench. The *Armstrong* geared box wrench is designed to give you all four without compromising any one factor. This unique combination allows you to perform tasks that, in the past, have required the use of both ratcheting box wrench and traditional box wrenches. The 72-tooth design provides a smooth, controlled ratcheting action. These wrenches are a necessity in today's industrial and automotive shops.



| Model No. | Mfg. No. | Size" | Length" | Price /Each |
|-----------|----------|-------|---------|-------------|
| VE505 | 27-510 | 3/8 | 6.74 | 32.70 |
| VE506 | 27-511 | 7/16 | 7.30 | 36.20 |
| VE507 | 27-512 | 1/2 | 8.58 | 41.50 |
| VE508 | 27-513 | 9/16 | 9.23 | 42.80 |
| VE509 | 27-514 | 5/8 | 10.54 | 44.50 |
| VE510 | 27-515 | 11/16 | 11.27 | 49.10 |
| VE511 | 27-516 | 3/4 | 12.64 | 52.40 |

ARMSTRONG INDUSTRIAL HAND TOOLS

| Model No. | Mfg. No. | Size mm | Length" | Price /Each |
|-----------|----------|---------|---------|-------------|
| VE512 | 54-510 | 10 | 6.74 | 35.30 |
| VE513 | 54-511 | 11 | 7.30 | 36.10 |
| VE514 | 54-512 | 12 | 7.92 | 43.90 |
| VE515 | 54-513 | 13 | 8.58 | 44.90 |
| VE516 | 54-514 | 14 | 9.23 | 46.90 |
| VE517 | 54-515 | 15 | 9.92 | 47.30 |
| VE518 | 54-516 | 16 | 10.54 | 48.40 |
| VE520 | 54-518 | 18 | 11.94 | 51.10 |
| VE521 | 54-519 | 19 | 12.64 | 52.50 |

12-POINT CHROME-PLATED COMBINATION WRENCHES

SAE

| Model No. | Mfg. No. | Size" | Length" | Price /Each |
|-----------|----------|--------|---------|-------------|
| T1079 | 25-208 | 1/4 | 5 | 17.70 |
| T1080 | 25-210 | 5/16 | 5 3/4 | 17.90 |
| T1081 | 25-211 | 11/32 | 5 3/4 | 17.90 |
| T1082 | 25-212 | 3/8 | 6 1/2 | 19.60 |
| T1083 | 25-214 | 7/16 | 7 1/4 | 21.10 |
| T1084 | 25-216 | 1/2 | 8 | 21.50 |
| T1085 | 25-218 | 9/16 | 8 3/4 | 24.50 |
| T1086 | 25-220 | 5/8 | 9 1/2 | 27.10 |
| T1087 | 25-222 | 11/16 | 10 1/4 | 29.40 |
| T1088 | 25-224 | 3/4 | 11 | 32.30 |
| T1089 | 25-226 | 13/16 | 11 3/4 | 34.90 |
| T1090 | 25-228 | 7/8 | 12 1/2 | 41.10 |
| T1091 | 25-230 | 15/16 | 13 1/4 | 44.80 |
| T1092 | 25-232 | 1 | 14 | 54.20 |
| T1093 | 25-234 | 1 1/16 | 14 3/4 | 62.80 |
| T1094 | 25-236 | 1 1/8 | 15 1/2 | 74.90 |
| T1095 | 25-238 | 1 3/16 | 16 5/16 | 79.60 |
| T1096 | 25-240 | 1 1/4 | 17 | 88.20 |

| Model No. | Mfg. No. | Size" | Length" | Price /Each |
|-----------|----------|---------|---------|-------------|
| T1097 | 25-242 | 1 5/16 | 20 1/8 | 91.70 |
| T1098 | 25-244 | 1 3/8 | 20 1/8 | 97.70 |
| T1099 | 25-246 | 1 7/16 | 21 1/8 | 112.00 |
| T1100 | 25-248 | 1 1/2 | 21 1/8 | 123.00 |
| T1101 | 25-252 | 1 5/8 | 24 1/8 | 135.00 |
| T1102 | 25-254 | 1 11/16 | 24 1/8 | 139.00 |
| T1103 | 25-256 | 1 3/4 | 25 5/8 | 148.00 |
| T1104 | 25-258 | 1 13/16 | 25 5/8 | 157.00 |
| T1105 | 25-260 | 1 7/8 | 27 1/8 | 186.00 |
| T1106 | 25-264 | 2 | 27 1/8 | 197.00 |
| T1107 | 25-266 | 2 1/16 | 27 1/8 | 229.00 |
| T1108 | 25-268 | 2 1/8 | 28 | 259.00 |
| T1109 | 25-270 | 2 3/16 | 28 | 275.00 |
| T1110 | 25-272 | 2 1/4 | 28 | 288.00 |
| T1111 | 25-276 | 2 3/8 | 30 | 355.00 |
| T1112 | 25-280 | 2 1/2 | 30 | 358.00 |
| T1113 | 25-282 | 2 9/16 | 32 | 506.00 |
| T1114 | 25-284 | 2 5/8 | 32 | 499.00 |
| T1115 | 25-288 | 2 3/4 | 32 | 578.00 |



METRIC

| Model No. | Mfg. No. | Size mm | Length mm | Price /Each |
|-----------|----------|---------|-----------|-------------|
| T1132 | 52-206 | 6 | 127 | 17.90 |
| T1133 | 52-207 | 7 | 127 | 18.30 |
| T1134 | 52-208 | 8 | 127 | 18.90 |
| T1135 | 52-209 | 9 | 156 | 21.10 |
| T1136 | 52-210 | 10 | 171 | 21.60 |
| T1137 | 52-211 | 11 | 184 | 21.90 |
| T1138 | 52-212 | 12 | 195 | 22.90 |
| T1139 | 52-213 | 13 | 207 | 23.90 |
| T1140 | 52-214 | 14 | 219 | 24.90 |
| T1141 | 52-215 | 15 | 231 | 27.40 |
| T1142 | 52-216 | 16 | 241 | 28.90 |
| T1143 | 52-217 | 17 | 256 | 31.50 |
| T1144 | 52-218 | 18 | 267 | 32.80 |
| T1145 | 52-219 | 19 | 279 | 34.10 |

| Model No. | Mfg. No. | Size mm | Length mm | Price /Each |
|-----------|----------|---------|-----------|-------------|
| T1146 | 52-220 | 20 | 292 | 37.40 |
| T1147 | 52-221 | 21 | 304 | 41.60 |
| T1148 | 52-222 | 22 | 318 | 43.30 |
| T1149 | 52-223 | 23 | 328 | 47.50 |
| T1150 | 52-224 | 24 | 338 | 52.30 |
| T1151 | 52-225 | 25 | 356 | 57.70 |
| T1152 | 52-226 | 26 | 375 | 59.90 |
| T1153 | 52-227 | 27 | 375 | 69.90 |
| T1154 | 52-228 | 28 | 394 | 77.90 |
| T1155 | 52-229 | 29 | 394 | 79.30 |
| T1156 | 52-230 | 30 | 414 | 82.10 |
| T1157 | 52-232 | 32 | 433 | 91.90 |
| T1158 | 52-236 | 36 | 511 | 114.00 |
| T1159 | 52-241 | 41 | 613 | 129.00 |
| T1160 | 52-246 | 46 | 651 | 195.00 |
| T1161 | 52-250 | 50 | 689 | 204.00 |

12-POINT SAE 45° OFFSET STRIKING FACE WRENCHES



| Model No. | Mfg. No. | Size" | Length" | Price /Each |
|-----------|----------|--------|---------|-------------|
| T1175 | 33-034 | 1 1/16 | 10 1/2 | 69.90 |
| T1176 | 33-036 | 1 1/8 | 10 1/2 | 71.10 |
| T1177 | 33-040 | 1 1/4 | 11 | 77.40 |
| T1178 | 33-042 | 1 5/16 | 11 | 79.80 |
| T1179 | 33-046 | 1 7/16 | 11 3/4 | 99.90 |

| Model No. | Mfg. No. | Size" | Length" | Price /Each |
|-----------|----------|---------|---------|-------------|
| T1180 | 33-048 | 1 1/2 | 11 3/4 | 96.20 |
| T1181 | 33-052 | 1 5/8 | 12 | 114.00 |
| T1182 | 33-054 | 1 11/16 | 12 | 116.00 |
| T1183 | 33-056 | 1 3/4 | 12 1/2 | 126.00 |
| T1184 | 33-058 | 1 13/16 | 12 1/2 | 128.00 |

| Model No. | Mfg. No. | Size" | Length" | Price /Each |
|-----------|----------|---------|---------|-------------|
| T1185 | 33-060 | 1 7/8 | 12 1/2 | 129.00 |
| T1186 | 33-062 | 1 15/16 | 13 1/4 | 139.00 |
| T1187 | 33-064 | 2 | 13 1/4 | 129.00 |
| T1188 | 33-068 | 2 1/8 | 13 1/2 | 135.00 |
| T1189 | 33-070 | 2 3/16 | 13 1/2 | 145.00 |

| Model No. | Mfg. No. | Size" | Length" | Price /Each |
|-----------|----------|---------|---------|-------------|
| T1190 | 33-072 | 2 1/4 | 13 1/2 | 155.00 |
| T1191 | 33-074 | 2 5/16 | 14 | 157.00 |
| T1192 | 33-076 | 2 3/8 | 14 | 163.00 |
| T1193 | 33-080 | 2 1/2 | 14 3/4 | 199.00 |
| T1194 | 33-082 | 2 9/16 | 14 3/4 | 205.00 |
| T1195 | 33-084 | 2 5/8 | 14 3/4 | 209.00 |
| T1196 | 33-088 | 2 3/4 | 16 | 224.00 |
| T1197 | 33-092 | 2 7/8 | 16 | 336.00 |
| T1198 | 33-094 | 2 15/16 | 16 | 252.00 |
| T1199 | 33-096 | 3 | 16 1/2 | 266.00 |
| T1200 | 33-100 | 3 1/8 | 16 1/2 | 283.00 |

12-POINT WRENCHES

METRIC SHORT CHROME-PLATED COMBINATION WRENCHES

| Model No. | Mfg. No. | Size mm | Length mm | Price /Each |
|-----------|----------|---------|-----------|-------------|
| T1162 | 52-109 | 9 | 124.00 | 16.50 |
| T1163 | 52-110 | 10 | 140.00 | 16.50 |
| T1164 | 52-111 | 11 | 147.30 | 16.90 |
| T1165 | 52-112 | 12 | 158.00 | 17.30 |
| T1166 | 52-113 | 13 | 165.60 | 17.90 |
| T1167 | 52-114 | 14 | 180.10 | 19.60 |
| T1168 | 52-115 | 15 | 191.00 | 21.50 |
| T1169 | 52-116 | 16 | 201.90 | 21.50 |
| T1170 | 52-117 | 17 | 212.90 | 23.20 |
| T1171 | 52-118 | 18 | 222.30 | 25.70 |
| T1172 | 52-119 | 19 | 244.90 | 25.70 |
| T1173 | 52-120 | 20 | 260.90 | 31.10 |
| T1174 | 52-121 | 21 | 277.60 | 31.10 |



SAE SHORT CHROME-PLATED COMBINATION WRENCHES

| Model No. | Mfg. No. | Size" | Length" | Price /Each |
|-----------|----------|-------|---------|-------------|
| T1116 | 25-108 | 1/4 | 3.96 | 14.70 |
| T1117 | 25-110 | 5/16 | 4.36 | 15.80 |
| T1118 | 25-111 | 11/32 | 4.88 | 15.90 |
| T1119 | 25-112 | 3/8 | 5.51 | 16.20 |
| T1120 | 25-114 | 7/16 | 5.80 | 16.80 |
| T1121 | 25-116 | 1/2 | 6.52 | 17.60 |
| T1122 | 25-118 | 9/16 | 7.09 | 19.60 |
| T1124 | 25-120 | 5/8 | 7.95 | 21.10 |
| T1125 | 25-122 | 11/16 | 8.75 | 23.90 |
| T1126 | 25-124 | 3/4 | 9.64 | 24.90 |
| T1128 | 25-126 | 13/16 | 10.93 | 29.60 |
| T1129 | 25-128 | 7/8 | 11.47 | 31.80 |
| T1130 | 25-130 | 15/16 | 12.52 | 35.30 |
| T1131 | 25-132 | 1 | 13.56 | 42.90 |



METRIC 45° OFFSET STRIKING FACE WRENCHES

| Model No. | Mfg. No. | Size mm | Length mm | Price /Each |
|-----------|----------|---------|-----------|-------------|
| T1201 | 59-032 | 32 | 279 | 99.70 |
| T1202 | 59-036 | 36 | 298 | 115.00 |
| T1203 | 59-041D | 41 | 305 | 124.00 |
| T1204 | 59-046D | 46 | 318 | 149.00 |
| T1205 | 59-050D | 50 | 337 | 153.00 |
| T1206 | 59-055 | 55 | 343 | 177.00 |
| T1207 | 59-060D | 60 | 356 | 229.00 |
| T1208 | 59-065 | 65 | 375 | 258.00 |
| T1209 | 59-070 | 70 | 406 | 299.00 |
| T1210 | 59-075 | 75 | 406 | 316.00 |
| T1211 | 59-080 | 80 | 419 | 345.00 |



WRENCHES

CRESCENT ADJUSTABLE WRENCHES



Crescent®

| Model No. | Mfg. No. | Length" | Max. Jaw Width" | Price /Each |
|------------------------------------|----------|---------|-----------------|-------------|
| CHROME FINISH | | | | |
| VE032 | AC24VS | 4 | 1/2 | 23.70 |
| VE033 | AC26VS | 6 | 15/16 | 23.80 |
| VE034 | AC28VS | 8 | 1 1/8 | 24.90 |
| VE035 | AC210VS | 10 | 1 5/16 | 32.10 |
| VE036 | AC212VS | 12 | 1 1/2 | 45.80 |
| VE037* | AC115 | 15 | 1 11/16 | 99.90 |
| VE038* | AC118 | 18 | 2 1/16 | 169.00 |
| VE039* | AC124 | 24 | 2 7/16 | 286.00 |
| CUSHION GRIP, CHROME FINISH | | | | |
| VE040 | AC24CVS | 4 | 1/2 | 24.80 |
| VE041 | AC26CVS | 6 | 15/16 | 24.90 |
| VE042 | AC28CVS | 8 | 1 1/8 | 26.60 |
| VE043 | AC210CVS | 10 | 1 5/16 | 32.50 |
| VE044 | AC212CVS | 12 | 1 1/2 | 46.90 |
| VE045* | AC115C | 15 | 1 11/16 | 109.00 |

| Model No. | Mfg. No. | Length" | Max. Jaw Width" | Price /Each |
|---|----------|---------|-----------------|-------------|
| BLACK PHOSPHATE FINISH | | | | |
| VE046 | AT14V | 4 | 1/2 | 21.10 |
| VE047 | AT16V | 6 | 15/16 | 19.80 |
| VE048 | AT18V | 8 | 1 1/8 | 19.90 |
| VE049 | AT110V | 10 | 1 5/16 | 25.50 |
| VE050 | AT112V | 12 | 1 1/2 | 39.60 |
| VE051* | AT115 | 15 | 1 11/16 | 89.90 |
| VE052* | AT118 | 18 | 2 1/16 | 149.00 |
| CUSHION GRIP, BLACK PHOSPHATE FINISH | | | | |
| VE055 | AT18CV | 8 | 1 1/8 | 22.50 |
| VE056 | AT110CV | 10 | 1 5/16 | 28.10 |
| VE057 | AT212CVS | 12 | 1 1/2 | 48.60 |

*Tapered handle

ADJUSTABLE WRENCHES

- Superior grade chrome vanadium steel
- Precision machined jaws
- Slim profile head slips into cramped quarters
- Tight tolerances ensure close fitting, wobble-free action
- Smooth, non-sticking mechanism
- Black nickel finish resists rust
- Meets ANSI standards

aurora tools®



| Model No. | Length" | Description | Price/Each |
|-----------|---------|--------------------------------|------------|
| TJZ100 | 6 | Standard jaw, composite body | 11.85 |
| TJZ101 | 8 | Reversible jaw, composite body | 17.00 |
| TJZ102 | 10 | Reversible jaw, composite body | 20.95 |
| TJZ103 | 12 | Reversible jaw, composite body | 28.45 |
| TJZ104 | 15 | Standard jaw, steel body | 49.95 |
| TJZ105 | 18 | Standard jaw, steel body | 93.25 |

6-PIECE ADJUSTABLE WRENCH SETS

- Kit includes: TJZ100, TJZ101, TJZ102, TJZ103, TJZ104 and TJZ105
- Model No. TLZ796
Price/Each \$214.00

COMBINATION WRENCHES

- Chrome vanadium steel for strength and durability
- Heat treated for consistent hardness
- Precision broached jaws for sure gripping
- 12-point box end for snug fit
- Thin walled construction for access in cramped quarters
- Meets ANSI standards



aurora tools®

| Model No. | Size" | Length" | Price /Each |
|------------|--------|---------|-------------|
| SAE | | | |
| TYK599 | 1/4 | 3 7/8 | 2.40 |
| TYK600 | 5/16 | 4 3/4 | 2.45 |
| TYK601 | 11/32 | 5 1/8 | 2.60 |
| TYK602 | 3/8 | 5 1/2 | 2.55 |
| TYK603 | 7/16 | 5 7/8 | 2.95 |
| TYK604 | 1/2 | 6 5/8 | 3.30 |
| TYK605 | 9/16 | 6 7/8 | 3.60 |
| TYK606 | 5/8 | 7 2/3 | 4.05 |
| TYK607 | 11/16 | 8 1/16 | 4.45 |
| TYK608 | 3/4 | 8 7/8 | 5.65 |
| TYK609 | 13/16 | 9 2/3 | 6.15 |
| TYK610 | 7/8 | 9 7/8 | 8.05 |
| TYK611 | 15/16 | 10 7/8 | 9.30 |
| TYK612 | 1 | 11 5/8 | 10.85 |
| TYK613 | 1 1/16 | 13 3/8 | 12.40 |
| TYK614 | 1 1/8 | 15 | 14.15 |
| TYK615 | 1 1/4 | 17 1/8 | 16.75 |

| Model No. | Size mm | Length mm | Price /Each |
|---------------|---------|-----------|-------------|
| METRIC | | | |
| TYK616 | 6 | 100 | 2.05 |
| TYK617 | 7 | 110 | 2.25 |
| TYK618 | 8 | 120 | 2.40 |
| TYK619 | 9 | 130 | 2.70 |
| TYK620 | 10 | 140 | 2.85 |
| TYK621 | 11 | 150 | 2.95 |
| TYK622 | 12 | 160 | 3.20 |
| TYK623 | 13 | 170 | 3.35 |
| TYK624 | 14 | 175 | 3.40 |
| TYK625 | 15 | 185 | 4.00 |
| TYK626 | 16 | 195 | 4.80 |
| TYK627 | 17 | 205 | 4.95 |
| TYK628 | 18 | 215 | 5.65 |
| TYK629 | 19 | 225 | 6.00 |
| TYK630 | 20 | 235 | 6.50 |
| TYK631 | 21 | 245 | 7.05 |
| TYK632 | 22 | 250 | 7.90 |
| TYK633 | 23 | 265 | 8.25 |
| TYK634 | 24 | 275 | 9.30 |
| TYK635 | 25 | 285 | 10.70 |
| TYK636 | 26 | 295 | 11.10 |
| TYK637 | 27 | 340 | 12.95 |
| TYK638 | 28 | 355 | 13.65 |
| TYK639 | 29 | 380 | 14.15 |
| TYK640 | 30 | 395 | 15.20 |
| TYK641 | 32 | 435 | 16.75 |

COMBINATION WRENCH SETS

- Chrome vanadium steel for strength and durability
- Heat treated for consistent hardness
- Precision broached jaws for sure gripping
- 12-point box end for snug fit
- Thin walled construction for access in cramped quarters
- Meets ANSI standards

aurora tools®



| Model No. | Description | Price/Each |
|-----------|--|------------|
| TLV053 | 11 SAE Combination Wrenches: 1/4", 5/16", 3/8", 7/16", 1/2", 9/16", 5/8", 11/16", 3/4", 13/16", 7/8" | 44.60 |
| TLV054 | 11 Metric Combination Wrenches: 7 mm, 8 mm, 9 mm, 10 mm, 11 mm, 12 mm, 13 mm, 14 mm, 15 mm, 17 mm, 19 mm | 44.60 |
| TLV055 | 14 SAE Combination Wrenches: 3/8", 7/16", 1/2", 9/16", 5/8", 11/16", 3/4", 13/16", 7/8", 15/16", 1", 1 1/16", 1 1/8", 1 1/4" | 94.95 |
| TLV056 | 14 Metric Combination Wrenches: 10 mm, 12 mm, 13 mm, 14 mm, 15 mm, 16 mm, 17 mm, 18 mm, 19 mm, 22 mm, 24 mm, 27 mm, 30 mm, 32 mm | 94.95 |

DOUBLE BOX SETS

GEARWRENCH

| Model No. | TDS937 | TDS890 | TDS902 |
|------------|---------------------------------------|---|--------------------------------------|
| Mfg. No. | 9240D | 9260 | 9224D |
| | 4 pcs. Double Box SAE 5/16" - 3/4" | 6 pcs. Double Box Metrics 8 mm - 19 mm | 4 pcs. Double Box E-Torx E6 - E24 |
| Price/Each | \$79.90 | \$116.00 | \$94.30 |



COMBINATION RATCHETING WRENCH SETS

- *Surface Drive*® nearly eliminates fastener rounding
- Exceed ANSI box-end strength requirement
- Forged metal
- Mirror chrome finish
- 5" ratcheting box end

GEARWRENCH



| Model No. | TDS803 | TDS792 | TDS903 | TDS904 | TDS888 | TDS842 |
|------------|--------------------------|---------------------------------|----------------------------|--------------------------------|----------------------------|---------------------------------|
| Mfg. No. | 9312 | 9416 | 9317 | 9417 | 9308 | 9412 |
| | 13 pcs. SAE 1/4" - 1" | 16 PCS. metrics 8 mm - 24 mm | 7 pcs. SAE 5/16" - 3/4" | 7 pcs. metrics 8 mm - 18 mm | 8 pcs. SAE 5/16" - 3/4" | 12 pcs. metrics 8 mm - 19 mm |
| Price/Each | \$219.00 | \$254.00 | \$75.10 | \$75.10 | \$102.00 | \$149.00 |

REVERSIBLE RATCHETING WRENCH SETS

- One-finger operated compact reversible lever - No side push pin
- 15° offset provides additional knuckle clearance

GEARWRENCH

| Model No. | TDS860 | TDS816 | TGZ813 |
|------------|----------------------------|---------------------------------|---------------------------------|
| Mfg. No. | 9533N | 9620N | 9602N |
| | 8 pcs. SAE 5/16" - 3/4" | 12 pcs. metrics 8 mm - 19 mm | 16 pcs. metrics 8 mm - 25 mm |
| Price/Each | \$129.00 | \$205.00 | \$362.00 |



FLEXIBLE RATCHETING WRENCH SETS

- Flex Head: Tilts up to 180° at any interval
- Spring washer design: providing continuous head tension
- One touch direction assistant

GEARWRENCH

| Model No. | TGZ814 | TGZ815 | TDS843 | TDS844 | TDS829 | TDS793 |
|------------|---------------------------|---------------------------------|---------------------------|---------------------------------|----------------------------|---------------------------------|
| Mfg. No. | 9702D | 9902D | 9700 | 9900D | 9701 | 9901D |
| | 13 pcs. SAE 5/16" - 1" | 16 pcs. metrics 8 mm - 24 mm | 7 pcs. SAE 3/8" - 3/4" | 7 pcs. metrics 10 mm - 19 mm | 8 pcs. SAE 5/16" - 3/4" | 12 pcs. metrics 8 mm - 19 mm |
| Price/Each | \$333.00 | \$399.00 | \$133.00 | \$136.00 | \$169.00 | \$229.00 |



XL X-BEAM™ REVERSIBLE COMBINATION RATCHETING WRENCH SETS

- Up to 25% longer to access those hard-to-reach fasteners
- *Surface Drive Plus*™ reduces fastener rounding and delivers up to 25% more torque
- Improved box end strength
- Up to 500% increase in surface contact area (vs. standard handle wrench)

GEARWRENCH

| Model No. | TLZ797 | TLZ798 |
|------------|-------------------------|-----------------------------|
| Mfg. No. | 85398 | 85388 |
| | 9 pcs. SAE 5/16" - 3/4" | 12 pcs. metric 8 mm - 19 mm |
| Price/Each | \$177.00 | \$234.00 |



XL: EXTRA LONG HIGH PERFORMANCE COMBINATION

- Up to 25% longer for more leverage
- *Surface Drive Plus*™ - patented anti-spread open end
- Ability to apply more torque
- Minimize fastener rounding
- Oval shaped handle

GEARWRENCH

| Model No. | TGZ820 | TGZ821 | TGZ822 | TGZ823 |
|------------|----------------------------|---------------------------------|--------------------------|---------------------------------|
| Mfg. No. | 85198 | 85098 | 85199 | 85099 |
| | 8 pcs. SAE 5/16" - 3/4" | 12 pcs. metrics 8 mm - 19 mm | 13 pcs. SAE 1/4" - 1" | 16 pcs. metrics 8 mm - 24 mm |
| Price/Each | \$127.00 | \$188.00 | \$279.00 | \$325.00 |





KLETON

Canada's Leading Material Handling Supplier



WRENCHES

STUBBY COMBINATION RATCHETING WRENCH SETS

- Ratcheting box end needs as little as 5° to move fasteners
- Up to 25% more torque with less fastener rounding



TLV401



| Model No. | Mfg. No. | Description | Price /Each |
|-----------|----------|------------------------------------|-------------|
| TLV401 | 9520D | Metric 10-piece set 10 mm to 19 mm | 155.00 |
| TLV402 | 9507D | SAE 7-piece set 3/8" to 3/4" | 106.00 |

STUBBY FLEX COMBINATION RATCHETING WRENCH SETS

- Flex Head tilts up to 180°
- Ratcheting box end needs as little as 5° to move fasteners
- Up to 25% more torque with less fastener rounding



| Model No. | Mfg. No. | Description | Price /Each |
|-----------|----------|------------------------------------|-------------|
| TLV403 | 9550 | Metric 10-piece set 10 mm to 19 mm | 232.00 |
| TLV404 | 9570 | SAE 7-piece set 3/8" to 3/4" | 169.00 |

INDEXING COMBINATION RATCHETING WRENCH SETS

- 13 locking positions allow access to hard-to-get places
- Wrench pumped by piston motion
- Ratcheting box end needs as little as 5° to move fasteners.
- Up to 25% more torque with less fastener rounding



| Model No. | Mfg. No. | Description | Price /Each |
|-----------|----------|-----------------------------------|-------------|
| TLV405 | 85488 | Metric 12-Piece Set 8 mm to 19 mm | 249.00 |
| TLV406 | 85498 | SAE 8-Piece Set 5/16" to 3/4" | 166.00 |

QUADBOX™ RATCHETING WRENCH SETS

- Each wrench has 4 different head sizes
- 4 dedicated recessed reversing levers
- 5° ratcheting mechanism for greater productivity
- Thin profile head for tight hard-to-reach places



| Model No. | TLZ799 | TLZ800 |
|------------|---------------|---------------|
| Mfg. No. | 85204 | 85215 |
| | 3 pcs. SAE | 4 pcs. metric |
| | 12 head sizes | 16 head sizes |
| | 5/16" to 1" | 8 mm to 24 mm |
| Price/Each | \$122.00 | \$153.00 |



VORTEX® RATCHET SET

- Up to 50% thinner head profile than conventional ratchet systems
- Pass-Thru® Ratchet & Socket System eliminates the need for deep sockets
- 11 locking head positions
- 5° ratcheting arc
- Up to 40% stronger than traditional ratchets by eliminating drive tang
- Dual material comfort grip handle



TLV384



TLV386



| Model No. | TLV384 | TLV386 |
|-------------------------|---|--|
| Mfg. No. | 891427 | 891226 |
| Drive Tang Size" | 1/4 | 1/2 |
| Finish | Full Polish Chrome | Full Polish Chrome |
| SAE Sockets Included | 5/32", 3/16", 7/32", 1/4", 9/32" 5/16", 3/8", 7/16", 1/2", 9/16" | 5/8", 11/16", 3/4", 13/16", 7/8", 15/16", 1", 1-1/16", 1-1/8", 1-1/4" |
| Metric Sockets Included | 3.5 mm, 4 mm, 4.5 mm, 5 mm, 5.5 mm, 6 mm, 7 mm, 8 mm, 9 mm, 10 mm, 11 mm, 12 mm, 13 mm | 15 mm, 16 mm, 17 mm, 18 mm, 19 mm, 20 mm, 21 mm, 22 mm, 24 mm, 27 mm, 30 mm, 32 mm |
| Additional Components | 1/4" Vortex Extension 6", 1/4" Vortex Extension 3", 1/4" Drive Pass-Thru® Quick-Release Adapters Carrying Case | 1/2" Drive (30 mm) Pass Thru Ratchet XL Locking Flex Head Ratchet, 1/2" Pass-Thru® Quick-Release Adapter, 1/2" Vortex Extension 6", Carrying Case |
| Price/Each | \$88.60 | \$236.00 |

12-POINT FULL POLISH FLEX HEAD WRENCHES



| Model No. | Mfg. No. | Opening" | Length" | Price /Each |
|-----------|----------|----------|---------|-------------|
| UM969 | 25-508 | 1/4 | 4.718 | 41.20 |
| UM970 | 25-510 | 5/16 | 5.562 | 42.10 |
| UM971 | 25-512 | 3/8 | 6.343 | 39.90 |
| UM972 | 25-514 | 7/16 | 7.125 | 39.70 |
| UM973 | 25-516 | 1/2 | 8.281 | 41.30 |

| Model No. | Mfg. No. | Opening" | Length" | Price /Each |
|-----------|----------|----------|---------|-------------|
| UM974 | 25-518 | 9/16 | 8.703 | 47.20 |
| UM975 | 25-520 | 5/8 | 9.484 | 52.30 |
| UM976 | 25-522 | 11/16 | 10.265 | 52.90 |
| UM978 | 25-526 | 13/16 | 11.875 | 74.60 |
| UM979 | 25-528 | 7/8 | 12.75 | 72.90 |

FULL POLISH DOUBLE HEAD FLARE NUT WRENCHES



| Model No. | Mfg. No. | Opening" | Length" | Price /Each |
|-----------|----------|-------------|---------|-------------|
| UN169* | 28-130 | 3/8 x 7/16 | 6.125 | 24.90 |
| UN170* | 28-135 | 1/2 x 9/16 | 7.5 | 35.20 |
| UN171* | 28-140 | 5/8 x 11/16 | 8.437 | 36.80 |

| Model No. | Mfg. No. | Opening" | Length" | Price /Each |
|-----------|----------|-------------|---------|-------------|
| UN172 | 28-145 | 3/4 x 1 | 9.125 | 47.30 |
| UN173 | 28-150 | 7/8 x 1 1/8 | 9.75 | 55.30 |

*Wrench has 6-point openings in both ends.

FULL POLISH COMBINATION FLARE NUT WRENCHES



| Model No. | Mfg. No. | Opening" | Length" | Price /Each |
|-----------|----------|----------|---------|-------------|
| UN175 | 28-212 | 3/8 | 5 | 26.60 |
| UN176 | 28-214 | 7/16 | 5.25 | 27.70 |
| UN177 | 28-216 | 1/2 | 6 | 29.20 |
| UN178 | 28-218 | 9/16 | 6.5 | 33.50 |

| Model No. | Mfg. No. | Opening" | Length" | Price /Each |
|-----------|----------|----------|---------|-------------|
| UN179 | 28-220 | 5/8 | 7 | 38.90 |
| UN180 | 28-222 | 11/16 | 8 | 42.20 |
| UN181 | 28-224 | 3/4 | 9.5 | 44.40 |
| UN182 | 28-228 | 7/8 | 12.13 | 54.20 |

FULL POLISH 15° & 60° OPEN END ANGLE WRENCHES



| Model No. | Mfg. No. | Opening" | Length" | Price /Each |
|-----------|----------|----------|---------|-------------|
| UN127 | 27-812 | 3/8 | 5 | 29.90 |
| UN128 | 27-814 | 7/16 | 5 1/2 | 29.90 |
| UN129 | 27-816 | 1/2 | 6 1/16 | 29.90 |
| UN130 | 27-818 | 9/16 | 6 1/2 | 31.10 |
| UN131 | 27-820 | 5/8 | 7 1/16 | 31.50 |
| UN132 | 27-822 | 11/16 | 7 1/2 | 33.90 |
| UN133 | 27-824 | 3/4 | 8 | 39.90 |
| UN134 | 27-826 | 13/16 | 8 9/16 | 47.20 |
| UN135 | 27-828 | 7/8 | 9 1/8 | 48.30 |
| UN136 | 27-830 | 15/16 | 9 3/4 | 52.70 |
| UN137 | 27-832 | 1 | 10-7/16 | 55.90 |
| UN138 | 27-834 | 1 1/16 | 11-3/16 | 61.60 |

| Model No. | Mfg. No. | Opening" | Length" | Price /Each |
|-----------|----------|----------|----------|-------------|
| UN139 | 27-836 | 1 1/8 | 11-15/16 | 64.20 |
| UN140 | 27-840 | 1 1/4 | 12-3/4 | 78.70 |
| UN141 | 27-844 | 1 3/8 | 12-1/2 | 89.90 |
| UN142 | 27-846 | 17/16 | 12-1/2 | 107.00 |
| UN143 | 27-848 | 1 1/2 | 12-1/2 | 112.00 |
| UN144 | 27-852 | 1 5/8 | 15-7/8 | 123.00 |
| UN145 | 27-854 | 1 11/16 | 16-9/16 | 125.00 |
| UN146 | 27-856 | 1 3/4 | 17-1/4 | 147.00 |
| UN147 | 27-858 | 1 13/16 | 18 | 155.00 |
| UN148 | 27-860 | 1 7/8 | 18-5/8 | 168.00 |
| UN149 | 27-864 | 2 | 19-1/4 | 197.00 |

FULL POLISH OPEN END WRENCHES



| Model No. | Mfg. No. | Opening" | Length" | Price /Each |
|-----------|----------|----------------|---------|-------------|
| SAE | | | | |
| UN009 | 26-007 | 3/16 x 1/4 | 3.875 | 14.40 |
| UN010 | 26-022 | 1/4 x 5/16 | 3.875 | 14.40 |
| UN011 | 26-031 | 5/16 x 11/32 | 4.5 | 14.40 |
| UN012 | 26-034 | 5/16 x 3/8 | 4.5 | 14.40 |
| UN013 | 26-043 | 3/8 x 7/16 | 4.875 | 15.20 |
| UN014 | 26-046 | 3/8 x 1/2 | 5.25 | 15.40 |
| UN015 | 26-058 | 7/16 x 1/2 | 5.625 | 15.40 |
| UN016 | 26-064 | 7/16 x 9/16 | 6.125 | 16.20 |
| UN017 | 26-067 | 1/2 x 9/16 | 6.125 | 16.30 |
| UN018 | 26-079 | 9/16 x 5/8 | 6.625 | 19.70 |
| UN019 | 26-094 | 5/8 x 11/16 | 7.25 | 23.30 |
| UN020 | 26-097 | 5/8 x 3/4 | 7.875 | 22.70 |
| UN021 | 26-106 | 11/16 x 3/4 | 8.562 | 24.80 |
| UN022 | 26-121 | 3/4 x 13/16 | 9.312 | 27.50 |
| UN023 | 26-124 | 3/4 x 7/8 | 9.75 | 29.90 |
| UN024 | 26-133 | 13/16 x 7/8 | 10.25 | 32.70 |
| UN025 | 26-139 | 7/8 x 15/16 | 11 | 39.60 |
| UN026 | 26-145 | 7/8 x 1 1/16 | 12 | 47.70 |
| UN027 | 26-151 | 15/16 x 1 | 12 | 47.70 |
| UN028 | 26-163 | 1 x 1 1/8 | 13 | 51.60 |
| UN029 | 26-166 | 1 1/16 x 1 1/8 | 13 | 54.20 |
| UN030 | 26-169 | 1 1/16 x 1 1/4 | 14 | 64.20 |
| UN031 | 26-172 | 1 1/8 x 1 1/4 | 14 | 81.90 |
| VE957 | 26-178 | 1 1/4 x 1 5/16 | 16.375 | 89.20 |
| UN032 | 26-187 | 1 5/16 x 1 1/2 | 16.375 | 99.80 |
| UN033 | 26-190 | 1 3/8 x 1 7/16 | 16.375 | 99.90 |
| UN034 | 26-199 | 1 7/16 x 1 5/8 | 18.25 | 115.00 |
| UN035 | 26-202 | 1 1/2 x 1 5/8 | 18.25 | 119.00 |

| Model No. | Mfg. No. | Opening mm | Length mm | Price /Each |
|-----------|----------|------------|-----------|-------------|
| METRIC | | | | |
| UN864 | 53-009 | 5 x 5.5 | 98.4 | 14.10 |
| UN865 | 53-016 | 6 x 7 | 98.4 | 14.50 |
| UN866 | 53-019 | 7 x 8 | 98.4 | 14.80 |
| UN867 | 53-022 | 8 x 9 | 114.3 | 14.90 |
| UN868 | 53-025 | 8 x 10 | 114.3 | 15.20 |
| WL263 | 53-034 | 10 x 11 | 123.8 | 16.20 |
| UN870 | 53-046 | 11 x 13 | 142.8 | 16.30 |
| UN871 | 53-052 | 12 x 13 | 155.5 | 16.30 |
| UN872 | 53-055 | 12 x 14 | 155.5 | 16.80 |
| UN873 | 53-061 | 13 x 15 | 155.5 | 19.80 |
| UN874 | 53-064 | 13 x 17 | 168.2 | 21.50 |
| UN875 | 53-067 | 14 x 15 | 168.2 | 19.80 |
| UN876 | 53-082 | 16 x 17 | 184.1 | 23.60 |
| UN877 | 53-085 | 16 x 18 | 200 | 25.40 |
| UN878 | 53-091 | 17 x 19 | 200 | 25.70 |
| UN879 | 53-096 | 18 x 19 | 217.5 | 27.90 |
| UN880 | 53-106 | 19 x 22 | 247.6 | 28.90 |
| UN881 | 53-115 | 20 x 22 | 247.6 | 31.10 |
| UN882 | 53-119 | 21 x 23 | 260.3 | 34.30 |
| UN883 | 53-127 | 22 x 24 | 279.4 | 39.30 |
| UN884 | 53-142 | 24 x 26 | 304.8 | 44.50 |
| UN885 | 53-145 | 24 x 27 | 304.8 | 57.20 |
| UN886 | 53-162 | 27 x 30 | 355.6 | 72.50 |
| UN887 | 53-175 | 30 x 32 | 355.6 | 87.70 |

THIN PATTERN PUMP WRENCHES



| Model No. | Mfg. No. | Opening" | Length" | Price /Each |
|-----------|----------|----------|---------|-------------|
| VE892 | 28-024 | 3/4 | 6.312 | 33.10 |
| VE893 | 28-028 | 7/8 | 6.312 | 33.10 |
| VE894 | 28-030 | 15/16 | 7.062 | 33.10 |
| VE895 | 28-032 | 1 | 7.062 | 33.10 |
| VE896 | 28-034 | 1 1/16 | 7.062 | 33.90 |
| VE897 | 28-036 | 1 1/8 | 7.062 | 37.70 |
| VE898 | 28-038 | 1 3/16 | 7.062 | 37.50 |
| VE899 | 28-040 | 1 1/4 | 7.062 | 39.70 |
| VE900 | 28-042 | 1 5/16 | 7.812 | 39.90 |
| VE901 | 28-044 | 1 3/8 | 7.812 | 39.90 |
| VE902 | 28-046 | 1 7/16 | 7.812 | 39.90 |

| Model No. | Mfg. No. | Opening" | Length" | Price /Each |
|-----------|----------|----------|---------|-------------|
| VE903 | 28-048 | 1 1/2 | 7.812 | 41.40 |
| VE904 | 28-050 | 1 9/16 | 7.812 | 47.20 |
| VE905 | 28-052 | 1 5/8 | 7.812 | 47.20 |
| VE906 | 28-056 | 1 3/4 | 8.625 | 47.90 |
| VE907 | 28-060 | 1 7/8 | 8.625 | 52.70 |
| VE908 | 28-064 | 2 | 8.625 | 52.70 |
| VE909 | 28-068 | 2 1/8 | 8.625 | 52.70 |
| VE910 | 28-072 | 2 1/4 | 8.625 | 52.70 |
| VE911 | 28-076 | 2 3/8 | 8.625 | 55.20 |
| VE912 | 28-080 | 2 1/2 | 8.625 | 55.20 |

WRENCHES

6 OR 12-POINT 25° OFFSET RATCHETING BOX WRENCHES



| Model No. | Mfg. No. | Opening" | Length" | Price /Each |
|------------|----------|---------------|---------|-------------|
| SAE | | | | |
| UN108* | 27-613 | 1/4 x 5/16 | 4.093 | 25.20 |
| UN109 | 27-614 | 1/4 x 5/16 | 4.328 | 25.20 |
| UN110* | 27-616 | 3/8 x 7/16 | 5.218 | 27.70 |
| UN111 | 27-617 | 3/8 x 7/16 | 5.968 | 27.50 |
| UN112* | 27-619 | 1/2 x 9/16 | 6.468 | 33.20 |
| UN113 | 27-620 | 1/2 x 9/16 | 6.515 | 32.90 |
| UN114 | 27-622 | 5/8 x 11/16 | 7.656 | 38.30 |
| UN115 | 27-624 | 5/8 x 3/4 | 7.656 | 38.60 |
| UN116 | 27-626 | 3/4 x 7/8 | 8.750 | 43.60 |
| UN117 | 27-628 | 13/16 x 15/16 | 8.750 | 44.50 |

| Model No. | Mfg. No. | Opening mm | Length mm | Price /Each |
|---------------|----------|------------|-----------|-------------|
| METRIC | | | | |
| UN939* | 54-637 | 7 x 8 | 104.0 | 25.50 |
| UN940* | 54-640 | 9 x 10 | 132.6 | 28.30 |
| UN941* | 54-643 | 11 x 12 | 164.3 | 34.40 |
| UN942* | 54-646 | 13 x 14 | 164.3 | 37.30 |
| UN943 | 54-649 | 15 x 17 | 194.5 | 36.60 |
| UN945 | 54-655 | 19 x 21 | 222.3 | 42.10 |

* 6 Points

12-POINT FULL POLISH 15° OFFSET BOX WRENCHES



| Model No. | Mfg. No. | Opening" | Length" | Price /Each |
|------------|----------|----------------|---------|-------------|
| SAE | | | | |
| UN044 | 26-643 | 3/8 x 7/16 | 7.75 | 21.80 |
| UN045 | 26-658 | 7/16 x 1/2 | 8.453 | 24.30 |
| UN046 | 26-667 | 1/2 x 9/16 | 9.14 | 25.90 |
| UN047 | 26-679 | 9/16 x 5/8 | 9.812 | 26.90 |
| UN049 | 26-697 | 5/8 x 3/4 | 10.562 | 27.90 |
| UN050 | 26-706 | 11/16 x 3/4 | 11.188 | 34.40 |
| UN051 | 26-724 | 3/4 x 7/8 | 12.656 | 33.40 |
| UN052 | 26-733 | 13/16 x 7/8 | 12.656 | 35.70 |
| UN055 | 26-751 | 15/16 x 1 | 15.375 | 62.80 |
| UN056 | 26-754 | 15/16 x 1 1/16 | 15.5 | 70.70 |
| UN057 | 26-763 | 1 x 1 1/8 | 16.625 | 71.50 |
| UN058 | 26-766 | 1 1/16 x 1 1/8 | 17 | 71.50 |
| UN059 | 26-769 | 1 1/16 x 1 1/4 | 17.25 | 64.90 |
| UN060 | 26-775 | 1 1/8 x 1 5/16 | 17.25 | 79.90 |
| UN061 | 26-778 | 1 1/4 x 1 5/16 | 19 | 82.50 |
| UN062 | 26-793 | 1 7/16 x 1 1/2 | 21.5 | 99.20 |
| UN063 | 26-799 | 1 7/16 x 1 5/8 | 21.5 | 119.00 |

| Model No. | Mfg. No. | Opening mm | Length mm | Price /Each |
|---------------|----------|------------|-----------|-------------|
| METRIC | | | | |
| UN891 | 53-616 | 6 x 7 | 179.4 | 21.50 |
| UN892 | 53-622 | 8 x 9 | 193.7 | 21.90 |
| UN893 | 53-634 | 10 x 11 | 196.9 | 21.90 |
| UN894 | 53-652 | 12 x 13 | 214.7 | 21.90 |
| UN895 | 53-661 | 13 x 15 | 246 | 23.90 |
| UN896 | 53-667 | 14 x 15 | 246 | 23.90 |
| TDR083 | 53-685 | 16 x 18 | 268.3 | 28.60 |
| UN898 | 53-691 | 17 x 19 | 284.2 | 29.90 |
| UN900 | 53-715 | 20 x 22 | 321.5 | 33.90 |
| UN901 | 53-719 | 21 x 23 | 321.5 | 51.30 |
| UN902 | 53-727 | 22 x 24 | 349.2 | 59.10 |
| UN903 | 53-742 | 24 x 26 | 390.5 | 59.90 |
| UN904 | 53-762 | 27 x 30 | 438.2 | 64.10 |
| UN905 | 53-775 | 30 x 32 | 482.6 | 74.30 |

RATCHETING FLARE NUT WRENCHES



| Model No. | Mfg. No. | Opening" | Length" | Price /Each |
|------------|----------|----------|---------|-------------|
| SAE | | | | |
| UN183 | 28-312 | 3/8 | 5.41 | 36.70 |
| UN184 | 28-314 | 7/16 | 5.41 | 36.70 |
| UN185 | 28-316 | 1/2 | 5.41 | 36.70 |
| UN186 | 28-318 | 9/16 | 7.25 | 43.90 |
| UN187 | 28-320 | 5/8 | 7.25 | 43.90 |
| UN188 | 28-322 | 11/16 | 7.25 | 43.90 |
| UN189 | 28-324 | 3/4 | 7.25 | 46.80 |
| UN190 | 28-326 | 13/16 | 9.35 | 54.40 |
| UN191 | 28-328 | 7/8 | 9.35 | 58.70 |
| UN193 | 28-332 | 1 | 9.35 | 58.70 |

| Model No. | Mfg. No. | Opening mm | Length mm | Price /Each |
|---------------|----------|------------|-----------|-------------|
| METRIC | | | | |
| UN955 | 55-307 | 7 | 137.4 | 35.90 |
| UN956 | 55-308 | 8 | 137.4 | 35.90 |
| UN957 | 55-309 | 9 | 137.4 | 35.90 |
| UN958 | 55-310 | 10 | 137.4 | 37.60 |
| UN959 | 55-311 | 11 | 137.4 | 37.60 |
| UN960 | 55-312 | 12 | 137.4 | 37.60 |
| UN961 | 55-313 | 13 | 137.4 | 43.20 |
| UN962 | 55-314 | 14 | 184.2 | 43.20 |
| UN963 | 55-315 | 15 | 184.2 | 43.20 |
| UN964 | 55-316 | 16 | 184.2 | 43.20 |
| UN965 | 55-317 | 17 | 184.2 | 45.10 |
| UN966 | 55-318 | 18 | 184.2 | 45.10 |
| UN967 | 55-319 | 19 | 184.2 | 45.10 |

12 POINT FULL POLISH 15° OFFSET SHORT BOX WRENCHES



| Model No. | Mfg. No. | Opening" | Length" | Price /Each |
|-----------|----------|------------|---------|-------------|
| UN040 | 26-543D | 3/8 x 7/16 | 4.75 | 22.50 |

| Model No. | Mfg. No. | Opening" | Length" | Price /Each |
|-----------|----------|------------|---------|-------------|
| UN042 | 26-567 | 1/2 x 9/16 | 5.5 | 23.40 |
| UN043 | 26-579 | 9/16 x 5/8 | 6 | 25.50 |

12-POINT FULL POLISH 45° OFFSET LONG BOX WRENCHES



| Model No. | Mfg. No. | Opening" | Length" | Price /Each |
|-----------|----------|-------------|---------|-------------|
| UN075 | 27-334 | 5/16 x 3/8 | 6.75 | 23.70 |
| UN076 | 27-343 | 3/8 x 7/16 | 7.312 | 26.90 |
| UN077 | 27-358 | 7/16 x 1/2 | 7.937 | 28.70 |
| UN079 | 27-367 | 1/2 x 9/16 | 8.67 | 29.50 |
| UN080 | 27-379 | 9/16 x 5/8 | 9.25 | 30.70 |
| UN081 | 27-394 | 5/8 x 11/16 | 9.844 | 33.40 |
| UN082 | 27-397 | 5/8 x 3/4 | 10.375 | 35.60 |

| Model No. | Mfg. No. | Opening" | Length" | Price /Each |
|-----------|----------|----------------|---------|-------------|
| UN083 | 27-406 | 11/16 x 3/4 | 10.375 | 36.60 |
| UN084 | 27-424 | 3/4 x 7/8 | 11.5 | 42.60 |
| UN086 | 27-451 | 15/16 x 1 | 14.5 | 58.50 |
| UN087 | 27-466 | 1 1/16 x 1-1/8 | 17 | 78.20 |
| UN088 | 27-469 | 1 1/16 x 1-1/4 | 18 | 90.40 |
| UN089 | 27-475 | 1 1/8 x 1-5/16 | 18 | 89.90 |
| UN090 | 27-481 | 1 1/4 x 1-7/16 | 19 | 122.00 |

12-POINT FULL POLISH 45° OFFSET METRIC BOX WRENCHES



| Model No. | Mfg. No. | Opening" | Length" | Price /Each |
|-----------|----------|----------|---------|-------------|
| UN909 | 54-322 | 8 x 9 | 190.5 | 22.90 |
| UN910 | 54-334 | 10 x 11 | 185.7 | 22.80 |
| UN911 | 54-352 | 12 x 13 | 201.6 | 23.40 |
| UN912 | 54-355 | 12 x 14 | 220.2 | 23.40 |
| UN913 | 54-361 | 13 x 15 | 227.8 | 25.10 |
| UN915 | 54-367 | 14 x 15 | 227.8 | 27.10 |
| UN917 | 54-385 | 16 x 18 | 250 | 26.70 |

| Model No. | Mfg. No. | Opening" | Length" | Price /Each |
|-----------|----------|----------|---------|-------------|
| UN918 | 54-391 | 17 x 19 | 275.4 | 31.70 |
| UN920 | 54-406 | 19 x 22 | 292.1 | 33.90 |
| UN921 | 54-415 | 20 x 22 | 339.7 | 34.90 |
| UN922 | 54-418 | 21 x 22 | 336.5 | 34.90 |
| UN923 | 54-419 | 21 x 23 | 336.5 | 57.60 |
| UN924 | 54-433 | 23 x 24 | 346 | 81.20 |
| UN925 | 54-445 | 24 x 27 | 397.7 | 81.20 |
| UN926 | 54-462 | 27 x 30 | 457.2 | 81.20 |
| UN927 | 54-475 | 30 x 32 | 457.2 | 129.00 |

*Has 6-point openings in both box ends.

12 POINT FULL POLISH 45° OFFSET SHORT BOX WRENCHES



| Model No. | Mfg. No. | Opening" | Length" | Price /Each |
|-----------|----------|------------|---------|-------------|
| UN070 | 27-143 | 3/8 x 7/16 | 4.5 | 20.30 |
| UN071 | 27-158 | 7/16 x 1/2 | 5.5 | 21.50 |

| Model No. | Mfg. No. | Opening" | Length" | Price /Each |
|-----------|----------|-------------|---------|-------------|
| UN072 | 27-167 | 1/2 x 9/16 | 5.5 | 21.70 |
| UN073 | 27-194 | 5/8 x 11/16 | 6.062 | 26.70 |

COMBINATION WRENCH SETS

ARMSTRONG[®] INDUSTRIAL HAND TOOLS

15-PC. 12-POINT FULL POLISH LONG

- Approximate weight 10.39 lbs.
 - Kit contains wrenches in the following sizes: 5/16", 3/8", 7/16", 1/2", 9/16", 5/8", 11/16", 3/4", 13/16", 7/8", 15/16", 1", 1 1/16", 1 1/8", 1 1/4"
 - Includes vinyl roll
- Model No. TDQ894**
Mfg. No. 25-642
Price/Each \$545.00



10-PC. 12-POINT FULL POLISH LONG - METRIC

- Approximate weight 2.96 lbs. (1344 g)
 - Kit contains wrenches from 10 mm to 19 mm
 - Includes vinyl roll
- Model No. T1078**
Mfg. No. 52-631
Price/Each \$243.00



10-PC. 12-POINT FULL POLISH LONG

- Approximate weight 5.4 lbs.
 - Kit contains wrenches in the following sizes: 7/16", 1/2", 9/16", 5/8", 11/16", 3/4", 13/16", 7/8", 15/16", 1"
 - Includes vinyl roll
- Model No. UQ068**
Mfg. No. 25-637
Price/Each \$299.00



9-PC. 12-POINT FULL POLISH LONG - METRIC

- Approximate weight 2.72 lbs. (1235 g)
 - Kit contains wrenches from 7 mm to 15 mm
 - Includes vinyl roll
- Model No. TDQ969**
Mfg. No. 52-630
Price/Each \$179.00



7-PC. 12-POINT FULL POLISH LONG

- Approximate weight 1.87 lbs.
 - Kit contains wrenches in the following sizes: 3/8", 7/16", 1/2", 9/16", 5/8", 11/16", 3/4"
 - Includes vinyl roll
- Model No. UM991**
Mfg. No. 25-631
Price/Each \$165.00



GEARED COMBINATION WRENCH SETS

10-PC. METRIC GEARED

- Approximate weight 4 lbs. (1680 g)
 - Kit contains wrenches from 10 mm to 19 mm
 - Includes vinyl roll
- Model No. TDQ933**
Mfg. No. 52-667
Price/Each \$349.00

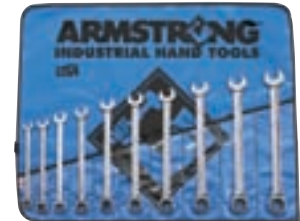

13-PC. 12-POINT FULL POLISH SHORT

- Approximate weight 3.96 lbs.
 - Kit contains wrenches in the following sizes: 1/4", 5/16", 3/8", 7/16", 1/2", 9/16", 5/8", 11/16", 3/4, 13/16", 7/8", 15/16", 1"
 - Includes vinyl roll
- Model No. T1075**
Mfg. No. 25-613
Price/Each \$345.00



10-PC. SAE GEARED

- Approximate weight 2.8 lbs.
 - Kit contains wrenches in the following sizes: 1/4", 5/16", 11/32", 3/8", 7/16", 1/2", 9/16", 5/8", 11/16", 3/4"
 - Includes vinyl roll
- Model No. TDQ944**
Mfg. No. 25-667
Price/Each \$313.00



7-PC. 12-POINT FULL POLISH EXTRA SHORT

- Approximate weight 1.1 lbs.
 - Kit contains wrenches in the following sizes: 3/8", 7/16", 1/2", 9/16", 5/8", 11/16", 3/4"
 - Includes vinyl roll
- Model No. UM983**
Mfg. No. 25-605
Price/Each \$145.00



7-PC. SAE GEARED

- Approximate weight 2.6 lbs.
 - Kit contains wrenches in the following sizes: 3/8", 7/16", 1/2", 9/16", 5/8", 11/16", 3/4"
 - Includes vinyl roll
- Model No. TDQ959**
Mfg. No. 25-661
Price/Each \$243.00



18-PC. 12-POINT FULL POLISH LONG METRIC

- Approximate weight 7.26 lbs. (3296 g)
 - Kit contains wrenches from 7 mm to 24 mm
 - Includes vinyl roll
- Model No. TDQ898**
Mfg. No. 52-638
Price/Each \$479.00



SCREWDRIVERS, INSERT BITS & HEX KEYS



INDIVIDUAL SCREWDRIVERS





- Industrial quality and strength
- Chrome vanadium steel blade
- Treated blade tip for a lifetime of performance
- Extra large ergonomic handle for maximum torque and comfort
- Screwdriver type indication on the base of the grip
- Colour-coded handle for square type
- Meets ANSI standards



aurora tools®

Screwdriver type indication on the base of the grip. (Colour-coded handle for square type.)



| Model No. | Tip Width" | Blade Length" | Price /Each |
|--|-------------------|---------------|-------------|
| SLOT ELECTRICIANS | | | |
|  TJZ057 | 1/8 | 3 | 2.70 |
| TJZ058 | 3/16 | 4 | 3.30 |
| TJZ059 | 3/16 | 6 | 3.90 |
| SLOT MECHANICS | | | |
| TJZ060 | 1/4 | 1 1/2 Stubby | 3.25 |
| TJZ061 | 1/4 | 4 | 3.95 |
|  TJZ062 | 1/4 | 5 | 4.20 |
| TJZ063 | 1/4 | 6 | 4.65 |
| TJZ064 | 5/16 | 6 | 6.35 |
| TJZ065 | 3/8 | 8 | 7.25 |
| PHILLIPS TIP | | | |
| | Tip Number | | |
| TJZ066 | #0 | 2 1/2 | 2.70 |
| TJZ067 | #1 | 3 1/4 | 3.45 |
|  TJZ068 | #2 | 4 | 3.95 |
| TJZ070 | #3 | 6 | 5.80 |
| TJZ069 | #2 | 1 1/2 Stubby | 3.25 |
| SQUARE TIP | | | |
| TJZ071 | #0 | 4 | 3.95 |
| TJZ072 | #1 | 4 | 4.55 |
| TJZ073 | #2 | 6 | 5.35 |
|  TJZ074 | #3 | 6 | 6.25 |
| TJZ075 | #1 | 1 1/2 Stubby | 2.95 |
| TJZ076 | #2 | 1 1/2 Stubby | 3.35 |
| TJZ077 | #3 | 1 1/2 Stubby | 3.35 |



SCREWDRIVER SETS



| Model No. | Description | Contents | Price/Each |
|-----------|-------------|---|------------|
| TJZ826 | 3-Pc Set | Square: #1, #2, #3 | 14.45 |
| TJZ827 | 7-Pc Set | Square: #1, #2 Phillips: #1, #2 Flat: 1/8", 1/4", 5/16" | 27.35 |
| TJZ828 | 16-Pc Set | Square: #0, #1, #2, #3, #2 Stubby Phillips: #0, #1, #2, #3, #2 Stubby Flat: 1/8", 3/16", 1/4", 5/16", 3/8", 1/4" Stubby | 62.00 |

aurora tools®

SCREWDRIVERS, INSERT BITS & HEX KEYS

KLEIN® CUSHION-GRIP SCREWDRIVERS

Klein® screwdrivers are made of the highest quality materials. Designed for the serious industrial user, these screwdrivers are the standard. Featuring cushion grip for user comfort and durability. Chrome plated shank and heat treated tip insure long life. Grip is resistant to gas, oil and water.



KLEIN TOOLS
For Professionals... Since 1857®



A. HEAVY-DUTY SQUARE SHANK, SLOT KEYSTONE TIP

| Model No. | Mfg. No. | Tip Width" | Shank Length" | Price /Each |
|-----------|----------|------------|---------------|-------------|
| TV501 | 600-4 | 1/4 | 4 | 19.50 |
| TV502 | 600-6 | 5/16 | 6 | 23.10 |
| TV503 | 600-8 | 3/8 | 8 | 31.40 |
| TV504 | 600-12 | 1/2 | 12 | 38.40 |

B. HEAVY-DUTY ROUND SHANK, SLOT KEYSTONE TIP

| Model No. | Mfg. No. | Tip Width" | Shank Length" | Price /Each |
|-----------|----------|------------|---------------|-------------|
| TV505 | 602-3 | 7/32 | 3 | 17.40 |
| TV506 | 602-4 | 1/4 | 4 | 18.20 |
| TV507 | 602-6 | 5/16 | 6 | 22.30 |
| TV508 | 602-8 | 3/8 | 8 | 29.30 |
| TV509 | 602-10 | 3/8 | 10 | 34.60 |
| TV510 | 602-12 | 3/8 | 12 | 38.90 |

C. HEAVY-DUTY ROUND SHANK, SLOT CABINET TIP

| Model No. | Mfg. No. | Tip Width" | Shank Length" | Price /Each |
|-----------|----------|------------|---------------|-------------|
| TV511 | 605-4 | 1/4 | 4 | 16.90 |
| TV512 | 605-6 | 1/4 | 6 | 18.40 |
| TV513 | 605-8 | 1/4 | 8 | 21.60 |
| TV514 | 605-10 | 1/4 | 10 | 24.10 |

D. ROUND SHANK, SLOT CABINET TIP

| Model No. | Mfg. No. | Tip Width" | Shank Length" | Price /Each |
|-----------|----------|------------|---------------|-------------|
| TV500* | 600-1 | 5/16 | 1 1/2 | 14.10 |
| TV515 | 601-3 | 3/16 | 3 | 14.70 |
| TV516 | 601-4 | 3/16 | 4 | 15.40 |
| TV517 | 601-6 | 3/16 | 6 | 16.40 |
| TV518 | 601-8 | 3/16 | 8 | 17.90 |
| TV519 | 601-10 | 3/16 | 10 | 20.60 |

*Stubby

E. ROUND SHANK, SPECIAL PROFILATED® PHILLIPS TIP

| Model No. | Mfg. No. | Tip No. | Shank Length" | Price /Each |
|-----------|----------|---------|---------------|-------------|
| TV520* | 603-1 | #2 | 1 1/2 | 14.60 |
| TV521 | 603-3 | #1 | 3 | 14.50 |
| TV522 | 603-4 | #2 | 6 | 16.80 |
| TV523 | 603-6 | #3 | 6 | 22.30 |
| TV524 | 603-7 | #2 | 7 | 18.80 |
| TV525 | 603-10 | #2 | 10 | 21.40 |

*Stubby

G. ROUND SHANK, TORX® TIP

| Model No. | Mfg. No. | Tip No. | Shank Length" | Price /Each |
|-----------|----------|---------|---------------|-------------|
| TV533 | 19542 | T15 | 4 | 15.40 |
| TV534 | 19543 | T20 | 4 | 15.40 |
| TV535 | 19544 | T25 | 4 | 15.40 |
| TV536 | 19545 | T27 | 4 | 15.40 |
| TV537 | 19546 | T30 | 4 | 15.40 |

J. CONDUIT FITTING & REAMING SCREWDRIVER

- Hood over tip keeps the tip from slipping out of the screws especially when working overhead
- Conduit reamer will accommodate 1/2", 3/4", 1" thin wall conduit
- Reamer part is replaceable

| Model No. | Mfg. No. | Tip Width" | Shank Length" | Price /Each |
|-----------|----------|------------|---------------|-------------|
| TJ880 | 85191 | 5/16 | 2 1/2 | 62.30 |

H. ROUND SHANK, CABINET TIP PLASTIC COATED

- Plastic coating is intended for circuit protection only
- Dipped coating is thin enough to be used in confined areas
- A preferred tool among telecommunications companies
- Screwdriver is not insulated for electricity
- Tip is exposed 1/8" beyond coating

| Model No. | Mfg. No. | Tip Width" | Shank Length" | Price /Each |
|-----------|----------|------------|---------------|-------------|
| TJ868 | 621-6 | 3/16 | 5 3/4 | 24.30 |
| TJ870 | 621-8 | 3/16 | 7 3/4 | 25.90 |
| TJ871 | 621-10 | 3/16 | 9 3/4 | 28.60 |
| TJ872* | 620-3 | 3/16 | 2 3/4 | 22.30 |
| TJ873* | 620-4 | 1/4 | 3 3/4 | 25.50 |
| TJ874* | 620-6 | 5/16 | 5 3/4 | 30.60 |
| TJ875* | 620-8 | 3/8 | 7 3/4 | 37.90 |

* Heavy-duty shank

7-PIECE CANADIAN BASIC SETS

Set includes 1 each of the following:

Square Tip: #1, #2, #3
Phillips Tip: #1, #2
Slot: 3/16", 1/4"

Model No. TJ881
Price/Each \$115.00



8-PIECE LONG & SHORT SETS

Set includes 1 each of the following:

Square Tip: #2 (shank length 8")
Phillips Tip: #2 (shank length 1 1/2"), #2 (shank length 10")
Slot: 1/2", 3/8", 3/16", 1/4" (shank length 1 1/2"), 1/4" (shank length 10")

Model No. TJ882
Price/Each \$185.00



SCREWDRIVERS, INSERT BITS & HEX KEYS

PRO-300

Feature extra large handle made of a rugged transparent plastic. Chrome plated, chrome-vanadium steel shank resists rust and ensures long life and durability.



FULLER

| Model No. | Tip Width" | Shank Length" | Price /Each |
|-----------------------------|------------|---------------|-------------|
| SLOT "POCKET" W/CLIP | | | |
| TV037 | 1/8 | 3 1/2 | 2.32 |
| SLOT ELECTRICIANS | | | |
| TV038 | 3/16 | 4 | 4.49 |
| TV039 | 3/16 | 6 | 5.14 |
| SLOT MECHANICS | | | |
| TV040 | 1/4 | 1 1/2 Stubby | 4.14 |
| TV041 | 1/4 | 4 | 5.66 |
| TV042 | 1/4 | 6 | 5.74 |
| TV043 | 5/16 | 6 | 6.69 |
| TV044 | 3/8 | 8 | 9.15 |
| SLOT HD SQUARE SHANK | | | |
| TV045 | 1/4 | 4 | 6.95 |
| TV046 | 5/16 | 6 | 8.98 |

PHILLIPS

| Model No. | Tip Number | Shank Length" | Price /Each |
|-----------|------------|---------------|-------------|
| TV047 | 2 | 1 1/2 Stubby | 4.10 |
| TV048 | 1 | 3 | 5.02 |
| TV049 | 2 | 4 | 5.10 |
| TV050 | 3 | 6 | 6.58 |
| TV051 | 0 | 2 1/2 | 2.36 |

SQUARE DRIVE

| | | | |
|-------|---|---|------|
| TV052 | 0 | 4 | 4.75 |
| TV053 | 1 | 4 | 5.58 |
| TV054 | 2 | 5 | 6.97 |
| TV055 | 3 | 5 | 6.14 |
| TV056 | 1 | 8 | 6.74 |
| TV057 | 2 | 8 | 6.74 |
| TV058 | 3 | 8 | 6.91 |

GOLDEN GRIP SCREWDRIVERS

Feature a large transparent plastic handle for both comfort and gripping power. Blade made of heat treated steel. Hardened tip for enhanced durability.

FULLER



| Model No. | Tip Width" | Shank Length" | Price /Each |
|---------------------|------------|---------------|-------------|
| SLOT CABINET | | | |
| TV002 | 1/8 | 3 | 1.68 |
| TV003 | 3/16 | 4 | 2.91 |
| TV004 | 3/16 | 6 | 3.11 |

SLOT MECHANICS

| | | | |
|-------|------|--------------|------|
| TV005 | 1/4 | 1 1/2 Stubby | 2.82 |
| TV006 | 1/4 | 4 | 3.46 |
| TV008 | 1/4 | 6 | 3.91 |
| TV009 | 5/16 | 6 | 5.21 |
| TV010 | 3/8 | 8 | 6.89 |

PHILLIPS

| Model No. | Tip Number | Shank Length" | Price /Each |
|-----------|------------|---------------|-------------|
| TV018 | 0 | 2 1/2 | 2.32 |
| TV019 | 1 | 3 1/4 | 3.01 |
| TV020 | 2 | 4 | 3.32 |
| TV021 | 2 | 1 1/2 Stubby | 2.98 |
| TV022 | 3 | 6 | 5.52 |

SQUARE

| | | | |
|-------|---|--------------|------|
| TV028 | 0 | 4 | 3.54 |
| TV029 | 1 | 4 | 3.84 |
| TV030 | 2 | 4 | 3.50 |
| TV031 | 3 | 4 | 3.54 |
| TV032 | 1 | 1 1/2 Stubby | 3.27 |
| TV033 | 2 | 1 1/2 Stubby | 2.98 |

SCRATCH AWL

| Model No. | Shank Length" | Price /Each |
|-----------|---------------|-------------|
| TV036 | 2 3/4 | 3.29 |



TACK PULLER

| Model No. | Shank Length" | Price/Each |
|-----------|---------------|------------|
| TV035 | 4 | 4.89 |

SIXPAC PLUS™ MULTI-BIT SCREWDRIVERS

- Sixpac Plus™ is the original Picquic® for professional or at home use
- Includes 7 bits: Robertson #1, #2, #3, Phillips #1, #2, slotted 3/16", 1/4"
- 1/4" Hex Powerbits, 3" long
- Bits are ideal for use in drills and power drivers
- Solid handle for maximum comfort and torque
- Anodized aluminum alloy shank for years of use

Model No. VE476
Mfg. No. 88001
Price/Each \$18.90



DASH 7™ MULTI-BIT SCREWDRIVERS

- Dash 7™ is a compact, durable no nonsense tool
- Includes 7 bits: Robertson #1, #2, #3, Phillips #1, #2, Slotted 3/16", 1/4"
- 1/4" Hex Powerbits, 2" long
- Anodized aluminum alloy shank for years of use
- Solid handle for maximum comfort and torque

Model No. TLZ551
Mfg. No. 08007
Price/Each \$10.90



MULTIQUE™ MULTI-BIT SCREWDRIVERS

- Multique™ has a slim handle for finer work
- Includes 7 bits: Robertson #0, #1, #2, Phillips #1, #2, Slotted 5/32", 3/16"
- 3/16" Hex Powerbits, 2.5" long
- Alloy shank with contoured handle, for comfort and ergonomics

Model No. TLZ553
Mfg. No. 05002
Price/Each \$11.75



STUBBY™ MULTI-BIT SCREWDRIVERS

- Stubby™ is ideal for drawers and close-quarter work
- Includes 6 bits: Robertson #1, #2, Phillips #1, #2, Slotted 3/16", 1/4"
- 1/4" Hex Plated Power bits, 1.3" long
- Aircraft alloy shank, light, strong and corrosion proof
- Solid handle for maximum comfort and torque

Model No. TLZ552
Mfg. No. 91002
Price/Each \$14.90



THE MARINER MULTIBIT SCREWDRIVER

- The Mariner comes with "Electroless" nickel plated bits making it an ideal choice for harsh & corrosive environments
- Includes 7 bits: Robertson #1, #2, #3, Phillips #1, #2, Slotted 3/16", 1/4"
- 1/4" Hex Plated Power bits, 3" long
- Anodized aluminum alloy shank for years of use
- Solid handle for maximum comfort and torque
- Handle Type: Plastic
- Overall Length: 6"

Model No. QN027
Mfg. No. 88002B
Price/Each \$29.50



SCREWDRIVER SETS

GOLDEN GRIP 6-PIECE

Square: #1, #2
Phillips: #1, #2
Slot: 3/16" x 4",
1/4" x 4"

Model No. TV088
Price/Each \$16.08

PRO 300 7-PIECE

Square: #1, #2
Phillips: #1, #2
Slot: 3/16" x 4",
1/4" x 4"
Pocket: 1/8" x 3 1/2"

Model No. TV093
Price/Each \$35.35



SCREWDRIVERS, INSERT BITS & HEX KEYS

MEGAPRO® 15-IN-1 ORIGINAL BIT LOADERS

- Pullout bit cartridge makes it easy to find, change and store bits
- Loaded with 7 double end professional quality bits:
 - Phillips #0, #1, #2, #3
 - Square #0, #1, #2, #3
 - Star #10, #15, #20, #25
 - Slotted #4, #6
- Shaft opening serves as a 1/4" hex nut driver
- Handle is made from engineered nylon/ABS resin
- Alloy steel shaft

Model No. TNB478
Mfg. No. 151NAS
Price/Each \$30.10



MEGAPRO®
Every bit better.

MEGAPRO® 15-IN-1 TAMPERPROOF BIT LOADERS

- Pullout bit cartridge handle makes it easy to find, change and store bits
- Tamperproof bit cartridge includes:
 - Hex Pin 1/8", 9/64", 5/32", 3/16"
 - Spanner #6, #8, #10, #12
 - Star Pin T10, T15, T20, T25, T27, T30
- Shaft opening serves as a 1/4" hex nut driver
- Handle is made from engineered nylon/ABS resin
- Alloy steel shaft

Model No. TNB480
Mfg. No. 151TP
Price/Each \$43.20



MEGAPRO®
Every bit better.

MEGAPRO® 4-IN-1 POCKET DRIVERS

- Offers professional quality multi-bit screwdrivers to meet all demands and saves time and space
- Features a double ended slotted bit (#1.5 & #2), and a double ended Phillips bit (#0 & #00)
- Specially contoured bits can reach depths of 15 mm (9/16")
- Comes with a pocket clip



Model No. TNB481
Mfg. No. 6PDRIVER-CC
Price/Each \$5.28

MEGAPRO®
Every bit better.

10-PC. MINI SCREWDRIVER SETS

- Plated alloy steel blades ensure a long life
- Hardened tips and shafts ensure a maximum workload
- Set includes one each of the following sizes:
 - Slotted: 3/64" x 1 1/2", 1/16" x 1 1/2", 5/64" x 1 1/2", 3/32" x 1 1/2";
 - Phillips: #000 x 1 1/2", #00 x 1 1/2", #0 x 1 1/2";
 - Torx®: T6 x 1 1/2", T7 x 1 1/2", T8 x 1 1/2"

Model No. TLV308
Mfg. No. 022200
Price/Each \$48.13

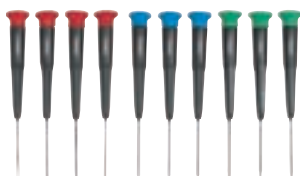

GENERAL®

MINI DIAL-A-BIT POCKET SCREWDRIVERS

- 12-in-1 precision screwdriver
- Extendable shaft from 5" to 7 1/4"
- Bits store in handle

TIPS:

- Phillips #0, #00, #000
- Square #0, #1
- Slotted #1.5, #2.5
- Star-Torx® T6, T7, T8, T10, T15

Model No. TKZ877
Mfg. No. 135-1812
Price/Each \$10.58



PRECISION SCREWDRIVER SET

- Black oxide non-slip tip
- Speed Zone® for turning in lower torque applications
- Tri-lobe ergonomic handle to offer optimal balance power and comfort
- Cap color indicates tip style

Model No. TNB966
Price/Each \$26.20



GEARWRENCH

SET INCLUDES:

| Model No. | Mfg. No. | Type | Tip Size | Shank Length | Price/Each |
|-----------|----------|-------------|----------|--------------|------------|
| TNB943 | 80031 | Cross Point | #00 | 60 mm | 4.85 |
| TNB944 | 80032 | Cross Point | #0 | 60 mm | 4.85 |
| TNB945 | 80033 | Cross Point | #1 | 60 mm | 4.85 |
| TNB946 | 80034 | Slot | 1.5 mm | 60 mm | 4.85 |
| TNB947 | 80035 | Slot | 2.0 mm | 60 mm | 4.85 |
| TNB948 | 80036 | Slot | 2.5 mm | 60 mm | 4.85 |

6-PC. MINI TORX® PRECISION SCREWDRIVER SET

- Black oxide non-slip tip
- Speed Zone® for turning in lower torque applications
- Tri-lobe ergonomic handle to offer optimal balance power and comfort
- Cap color indicates tip style

Model No. TNB967
Price/Each \$27.10



GEARWRENCH

SET INCLUDES:

| Model No. | Mfg. No. | Type | Tip Size | Shank Length | Price/Each |
|-----------|----------|------|----------|--------------|------------|
| TNB949 | 80037 | Torx | T5 | 60 mm | 5.15 |
| TNB950 | 80038 | Torx | T6 | 60 mm | 5.15 |
| TNB951 | 80039 | Torx | T7 | 60 mm | 4.95 |
| TNB952 | 80040 | Torx | T8 | 60 mm | 4.95 |
| TNB953 | 80041 | Torx | T9 | 60 mm | 4.95 |
| TSB394 | 80042D | Torx | T10 | 60 mm | 4.95 |

7-PC. PRECISION ULTRA TECH™ SCREWDRIVER SETS

SLOTTED, PHILLIPS & TORX®

- Set contains:
 - 1/16" slotted
 - 3/32" slotted
 - 1/8" slotted
 - #00 Phillips
 - #0 Phillips
 - #1 Phillips
 - Torx® T6

Model No. TLZ543
Price/Each \$33.57



GENERAL®

18-PC. PRECISION ULTRATECH™ SCREWDRIVER SETS

- Black oxide blades ensure a precision fit and prevent corrosion
- Eight sided cushion grip has a non-slip surface
- Close tolerance locking screw chuck holds blades securely in place
- Contoured fingertip swivel head allows greater pressure to be applied to the blade
- Packaged in a pocket sized fitted zipper case for secure storage
- Set includes:
 - 1 Versa-Grip multi-blade handle,
 - 17 interchangeable blades:
 - Slotted 3/64", 1/16", 5/64", 3/32", Phillips #000, #00,
 - Torx® T6, T7, T8, T9, Hex 0.050,
 - 1/16", 5/64", nut-drivers 3/32", 1/8", 5/32", awl/scribe.

Model No. TLZ550
Mfg. No. 063518
Price/Each \$43.24



GENERAL®

SCREWDRIVERS, INSERT BITS & HEX KEYS

HOLLOW SHAFT NUT DRIVERS, 6-POINT OPENING



IMPERIAL

| Model No. | Mfg. No. | Opening" | Wt. lbs. | Drive End" | Shaft Length" | Handle Size" Dia. x Length | Overall Length" | Bolt Clearance" | Handle Colour | Price /Each |
|-----------|----------|----------|----------|------------|---------------|----------------------------|-----------------|-----------------|---------------|-------------|
| U0163 | 66-806 | 3/16 | 0.12 | 0.328 | 3 | 1.00 x 3.6 | 6.62 | 0.140 | Black | 13.20 |
| U0164 | 66-807 | 7/32 | 0.12 | 0.373 | 3 | 1.00 x 3.6 | 6.62 | 0.140 | Brown | 12.60 |
| U0165 | 66-808 | 1/4 | 0.13 | 0.421 | 3 | 1.00 x 3.6 | 6.62 | 0.196 | Red | 13.10 |
| U0166 | 66-809 | 9/32 | 0.13 | 0.451 | 3 | 1.00 x 3.6 | 6.62 | 0.203 | Orange | 12.30 |
| U0167 | 66-810 | 5/16 | 0.14 | 0.490 | 3 | 1.00 x 3.6 | 6.62 | 0.196 | Amber | 14.60 |
| U0168 | 66-811 | 11/32 | 0.14 | 0.531 | 3 | 1.00 x 3.6 | 6.62 | 0.203 | Green | 15.30 |
| U0169 | 66-812 | 3/8 | 0.16 | 0.570 | 3 | 1.00 x 3.6 | 6.62 | 0.272 | Blue | 15.10 |
| U0170 | 66-814 | 7/16 | 0.19 | 0.648 | 3 | 1.06 x 4.0 | 7.00 | 0.272 | Brown | 19.50 |
| U0171 | 66-816 | 1/2 | 0.21 | 0.718 | 3 | 1.06 x 4.0 | 7.00 | 0.333 | Red | 19.60 |
| U0172 | 66-818 | 9/16 | 0.24 | 0.806 | 4 | 1.19 x 4.5 | 8.50 | 0.397 | Red | 21.90 |
| U0173 | 66-820 | 5/8 | 0.27 | 0.890 | 4 | 1.19 x 4.5 | 8.50 | 0.453 | Red | 21.70 |

METRIC

| Model No. | Mfg. No. | Opening mm | Wt. lbs. | Drive End mm | Shaft Length mm | Handle Size mm Dia. x Length | Overall Length mm | Bolt Clearance mm | Price /Each |
|-----------|----------|------------|----------|--------------|-----------------|------------------------------|-------------------|-------------------|-------------|
| U0174 | 66-829 | 4 | 0.10 | 8.0 | 76.0 | 25 x 91 | 167.0 | 4.0 | 12.10 |
| U0175 | 66-831 | 5 | 0.12 | 10.0 | 76.0 | 25 x 91 | 167.0 | 4.0 | 12.10 |
| U0176 | 66-832 | 5.5 | 0.12 | 10.0 | 76.0 | 25 x 91 | 167.0 | 4.0 | 13.20 |
| U0177 | 66-833 | 6 | 0.13 | 11.0 | 76.0 | 25 x 91 | 167.0 | 5.0 | 12.30 |
| U0178 | 66-834 | 7 | 0.13 | 12.0 | 76.0 | 25 x 91 | 167.0 | 5.0 | 11.70 |
| U0179 | 66-835 | 8 | 0.14 | 13.0 | 76.0 | 25 x 91 | 167.0 | 5.0 | 12.90 |
| U0180 | 66-836 | 9 | 0.14 | 14.0 | 76.0 | 25 x 91 | 167.0 | 5.0 | 13.20 |
| U0181 | 66-837 | 10 | 0.15 | 15.0 | 76.0 | 26 x 101 | 177.0 | 7.0 | 14.50 |
| U0182 | 66-838 | 11 | 0.18 | 17.0 | 76.0 | 26 x 101 | 177.0 | 7.0 | 15.60 |
| U0183 | 66-839 | 12 | 0.20 | 17.0 | 76.0 | 26 x 101 | 177.0 | 7.0 | 21.90 |
| U0184 | 66-840 | 13 | 0.27 | 18.0 | 76.0 | 26 x 101 | 177.0 | 8.0 | 22.20 |

7-Pc. Nut Driver Sets

- Includes: 7 nut drivers from 1/4" to 1/2"
- Approximate weight: 1.45 lbs.
- Model No. UO185
- Price/Each \$128.00



VINYL ROLL
Model No. TDQ611
Price/Each \$23.60

11-PC. NUT DRIVER SETS

- Includes: 11 nut drivers from 4 mm to 13 mm
- Approximate weight: 1.98 lbs.
- Model No. UO189
- Price/Each \$169.00



- Includes 11 nut drivers from 3/16" to 5/8"
- Approximate weight: 2.31 lbs.
- Model No. UO187
- Price/Each \$182.00

CUSHION GRIP NUT DRIVERS

- Solid plastic amber handle with cushion grip for user comfort
- Handle caps are colour-coded for easy size identification
- Full hollow shaft permits turning nuts on long screws
- Chrome-plated shaft to help insure long life
- Available with or without magnetic tip



| Shaft Size" | Shaft Length" | Colour Code | Model No. | Mfg. No. | Price /Each | Magnetic Model No. | Mfg. No. | Price /Each |
|-------------|---------------|-------------|-----------|-----------|-------------|--------------------|------------|-------------|
| 3/16 | 3 | Black | TV600 | 630-3/16 | 14.50 | TLZ559 | 630-3/16M | 17.90 |
| 1/4 | 3 | Red | TV601 | 630-1/4 | 14.50 | TBT557 | 630-1/4M | 18.50 |
| 5/16 | 3 | Yellow | TV602 | 630-5/16 | 14.70 | TBT558 | 630-5/16M | 19.90 |
| 11/32 | 3 | Green | TV603 | 630-11/32 | 15.20 | TLZ560 | 630-11/32M | 21.10 |
| 3/8 | 3 | Blue | TV604 | 630-3/8 | 15.40 | TLZ561 | 630-3/8M | 22.20 |
| 7/16 | 3 | Brown | TV605 | 630-7/16 | 17.40 | TLZ562 | 630-7/16M | 24.90 |
| 1/2 | 3 | Red | TV606 | 630-1/2 | 18.40 | TLZ563 | 630-1/2M | 26.40 |
| 9/16 | 3 | Orange | TV607 | 630-9/16 | 23.70 | - | - | - |
| 5/8 | 3 | Yellow | TV608 | 630-5/8 | 25.40 | - | - | - |
| 3/16 | 6 | Black | TBT572 | 646-3/16 | 15.70 | TLZ564 | 646-3/16M | 19.40 |
| 1/4 | 6 | Red | TBT569 | 646-1/4 | 15.90 | TBT570 | 646-1/4M | 21.10 |
| 5/16 | 6 | Yellow | TBT574 | 646-5/16 | 15.90 | TBT575 | 646-5/16M | 22.60 |
| 11/32 | 6 | Green | TBT571 | 646-11/32 | 16.30 | TLZ565 | 646-11/32M | 22.30 |
| 3/8 | 6 | Blue | TBT573 | 646-3/8 | 16.40 | TLZ566 | 646-3/8M | 23.40 |
| 7/16 | 6 | Brown | TBT577 | 646-7/16 | 18.80 | TLZ567 | 646-7/16M | 26.50 |
| 1/2 | 6 | Red | TBT568 | 646-1/2 | 20.20 | TLZ568 | 646-1/2M | 27.90 |
| 9/16 | 6 | Orange | TBT578 | 646-9/16 | 25.80 | - | - | - |
| 5/8 | 6 | Yellow | TBT576 | 646-5/8 | 27.30 | - | - | - |

7-PC CUSHION GRIP NUT DRIVER SETS

- Includes: 7 nut drivers from 3/16" to 1/2"
- Available with or without magnetic tip



3" SHAFTS

Model No. TV617
Mfg. No. 631
Price/Each \$99.90

Model No. TLZ570
Magnetic Tips
Mfg. No. 631M
Price/Each \$139.00

6" SHAFTS

Model No. TBS773
Mfg. No. 647
Price/Each \$113.00

Model No. TLZ569
Magnetic Tips
Mfg. No. 647M
Price/Each \$156.00



CROSS-CHECK™ TAMPER PROOF INDICATOR TUBES

- Convenient method for visually identifying loosening and tampering in assemblies, bolts, fasteners, and nuts
- Safe for use on most surfaces
- Available in highly visible fluorescent colours
- Excellent adhesion
- Withstands temperatures of -20°F to 400°F once cured
- Provides warranty protection
- Dry Time: <1 hr
- Shelf Life: 2 years
- Net Volume: 1 oz.

| Model No. | Colour | Price/Each |
|-----------|--------|------------|
| AF052 | Orange | 6.86 |
| AF053 | Green | 6.86 |
| AF054 | Red | 6.86 |
| AF055 | Yellow | 6.86 |
| AF056 | Blue | 6.86 |



SCREWDRIVERS, INSERT BITS & HEX KEYS

1/4" TORQ-SET® INSERT BITS



| Model No. | Mfg. No. | Point Size | Overall Length" | Price /Each |
|-----------|----------|------------|-----------------|-------------|
| UQ709 | 212-0 | 0 | 1.00 | 10.37 |
| UQ710 | 212-1 | 1 | 1.00 | 10.37 |
| UQ711 | 212-2 | 2 | 1.00 | 10.46 |
| UQ712 | 212-3 | 3 | 1.00 | 10.46 |
| UQ713 | 212-4 | 4 | 1.00 | 10.16 |
| UQ714 | 212-5 | 5 | 1.00 | 9.96 |
| UQ715 | 212-6 | 6 | 1.00 | 10.19 |
| UQ716 | 212-8 | 8 | 1.00 | 10.16 |
| UQ717 | 212-10 | 10 | 1.00 | 10.16 |
| UQ718 | 212-1/4 | 1/4 | 1.00 | 10.16 |

1/4" BIT HOLDERS, QUICK RELEASE



| Model No. | Mfg. No. | Overall Length" | Price/Each |
|-----------|-------------|-----------------|------------|
| UQ860 | QR-M-490-2 | 2.00 | 81.50 |
| UQ861 | QR-M-490-A | 2.91 | 37.50 |
| UQ862 | QR-M-490-A6 | 6.00 | 153.75 |

1/4" MAGNETIC BIT HOLDERS WITH O-RING RETAINER



| Model No. | Mfg. No. | Overall Length" | Price/Each |
|-----------|------------|-----------------|------------|
| UQ858 | M-490-2-OR | 2.00 | 27.75 |
| UQ859 | M-490-OR | 3.00 | 26.70 |

1/4" HEX DRIVE NUTSETTER



| Model No. | Mfg. No. | Dim." | Type | Overall Length" | Price/Each |
|-----------|------------|-------|--------------|-----------------|------------|
| UQ763 | 6N-0806-2 | 3/16 | Non-magnetic | 2.00 | 25.55 |
| UQ764 | 6N-0806-3 | 3/16 | Non-magnetic | 3.00 | 26.26 |
| UQ766 | 6N-0808-2 | 1/4 | Non-magnetic | 2.00 | 26.05 |
| UQ767 | 6N-0808-3 | 1/4 | Non-magnetic | 3.00 | 26.40 |
| UQ768 | 6N-0808-6 | 1/4 | Non-magnetic | 6.00 | 41.44 |
| UQ769 | 6N-0810-2 | 5/16 | Non-magnetic | 2.00 | 28.81 |
| UQ770 | 6N-0810-3 | 5/16 | Non-magnetic | 3.00 | 29.34 |
| UQ771 | 6N-0810-6 | 5/16 | Non-magnetic | 6.00 | 41.97 |
| UQ772 | 6N-0811-2 | 11/32 | Non-magnetic | 2.00 | 37.77 |
| UQ774 | 6N-0812-2 | 3/8 | Non-magnetic | 2.00 | 36.15 |
| UQ775 | 6N-0812-3 | 3/8 | Non-magnetic | 3.00 | 32.42 |
| UQ776 | 6N-0812-6 | 3/8 | Non-magnetic | 6.00 | 42.32 |
| UQ777 | 6N-0814-2 | 7/16 | Non-magnetic | 2.00 | 33.13 |
| UQ778 | 6N-0814-3 | 7/16 | Non-magnetic | 3.00 | 33.63 |
| UQ780 | 6N-0816-2 | 1/2 | Non-magnetic | 2.00 | 36.42 |
| UQ781 | 6N-0816-3 | 1/2 | Non-magnetic | 3.00 | 41.15 |
| UQ782 | 6N-0818-2 | 9/16 | Non-magnetic | 2.00 | 44.05 |
| UQ783 | M6N-0806-2 | 3/16 | Magnetic | 2.00 | 31.75 |
| UQ784 | M6N-0806-3 | 3/16 | Magnetic | 3.00 | 32.39 |
| UQ785 | M6N-0806-6 | 3/16 | Magnetic | 6.00 | 43.03 |
| UQ786 | M6N-0808-2 | 1/4 | Magnetic | 2.00 | 32.57 |
| UQ787 | M6N-0808-3 | 1/4 | Magnetic | 3.00 | 33.22 |
| UQ788 | M6N-0808-6 | 1/4 | Magnetic | 6.00 | 47.58 |
| UQ789 | M6N-0810-2 | 5/16 | Magnetic | 2.00 | 35.92 |
| UQ790 | M6N-0810-3 | 5/16 | Magnetic | 3.00 | 36.68 |
| UQ791 | M6N-0810-6 | 5/16 | Magnetic | 6.00 | 48.90 |
| UQ792 | M6N-0811-2 | 11/32 | Magnetic | 2.00 | 53.30 |
| UQ794 | M6N-0812-2 | 3/8 | Magnetic | 2.00 | 39.74 |
| UQ795 | M6N-0812-3 | 3/8 | Magnetic | 3.00 | 40.62 |
| UQ796 | M6N-0812-6 | 3/8 | Magnetic | 6.00 | 51.10 |
| UQ797 | M6N-0814-2 | 7/16 | Magnetic | 2.00 | 40.73 |
| UQ798 | M6N-0814-3 | 7/16 | Magnetic | 3.00 | 42.53 |
| UQ799 | M6N-0814-6 | 7/16 | Magnetic | 6.00 | 55.80 |
| UQ800 | M6N-0816-2 | 1/2 | Magnetic | 2.00 | 42.56 |
| UQ801 | M6N-0816-3 | 1/2 | Magnetic | 3.00 | 50.95 |
| UQ802 | M6N-0818-2 | 9/16 | Magnetic | 2.00 | 62.56 |

1/4" TORX® POWER BITS



| Model No. | Mfg. No. | Point Size | Overall Length" | Price /Each |
|-----------|------------|------------|-----------------|-------------|
| UQ744 | 49-TX-05 | T-5 | 1.94 | 13.30 |
| UQ745 | 49-TX-06 | T-6 | 1.94 | 13.07 |
| UQ746 | 49-TX-07 | T-7 | 1.94 | 13.57 |
| UQ747 | 49-TX-08 | T-8 | 1.94 | 13.07 |
| UQ748 | 49-TX-09 | T-9 | 1.94 | 13.48 |
| UQ749 | 49-TX-10 | T-10 | 1.94 | 8.31 |
| UQ750 | 49-B-TX-10 | T-10 | 3.50 | 10.75 |
| UQ751 | 49-TX-15 | T-15 | 1.94 | 8.31 |
| UQ752 | 49-B-TX-15 | T-15 | 3.50 | 10.40 |
| UQ753 | 49-TX-20 | T-20 | 1.94 | 8.34 |
| UQ754 | 49-B-TX-20 | T-20 | 3.50 | 10.40 |
| UQ755 | 49-TX-25 | T-25 | 1.94 | 8.34 |
| UQ756 | 49-B-TX-25 | T-25 | 3.50 | 10.40 |
| UQ757 | 49-TX-27 | T-27 | 1.94 | 8.66 |
| UQ758 | 49-B-TX-27 | T-27 | 3.50 | 10.84 |
| UQ759 | 49-TX-30 | T-30 | 1.94 | 8.37 |
| UQ760 | 49-B-TX-30 | T-30 | 3.50 | 10.75 |
| UQ761 | 49-TX-40 | T-40 | 1.94 | 8.66 |
| UQ762 | 49-B-TX-40 | T-40 | 3.50 | 10.75 |

1/4" NON-MAGNETIC BIT HOLDERS



| Model No. | Mfg. No. | Overall Length" | Price/Each |
|-----------|----------|-----------------|------------|
| UQ843 | 490 | 2.13 | 8.66 |
| UQ844 | 490-3 | 3.00 | 33.42 |
| UQ845 | 490-4 | 4.00 | 31.63 |
| UQ846 | 490-5 | 5.00 | 52.42 |
| UQ847 | 490-6 | 6.00 | 26.84 |
| UQ848 | 490-8 | 8.00 | 46.11 |
| UQ849 | 490-10 | 10.00 | 47.58 |

1/4" NUTSETTER FOR SAE SHEET METAL SCREWS



| Model No. | Mfg. No. | Dim." | Type | Overall Length" | Price /Each |
|-----------|----------|-------|--------------|-----------------|-------------|
| UQ803 | DB-08 | 1/4 | Non-magnetic | 2.56 | 23.05 |
| UQ804 | DB-10 | 5/16 | Non-magnetic | 2.56 | 18.74 |
| UQ805 | DB-12 | 3/8 | Non-magnetic | 2.56 | 16.86 |
| UQ806 | MDA-08 | 1/4 | Magnetic | 1.75 | 12.48 |
| UQ807 | MDA-10 | 5/16 | Magnetic | 1.75 | 12.47 |
| UQ808 | MDA-12 | 3/8 | Magnetic | 1.75 | 17.27 |
| UQ809 | MDA-14 | 7/16 | Magnetic | 2.00 | 38.77 |
| UQ811 | MHM-1310 | 5/16* | Magnetic | 1.13 | 38.56 |
| UQ812 | MHM-1912 | 3/8* | Magnetic | 1.75 | 47.28 |

* Insert bits

1/4" NUTSETTER FOR METRIC SHEET METAL SCREWS



| Model No. | Mfg. No. | Dim." | Type | Overall Length mm | Price /Each |
|-----------|----------|-------|----------|-------------------|-------------|
| UQ813 | MDA-6MM | 6 | Magnetic | 44.5 | 25.20 |
| UQ814 | MDA-7MM | 7 | Magnetic | 44.5 | 12.13 |
| UQ815 | MDA-8MM | 8 | Magnetic | 44.5 | 12.13 |
| UQ816 | MDA-10MM | 10 | Magnetic | 44.5 | 17.15 |
| UQ818 | MHM-7MM | 7* | Magnetic | 31.8 | 50.51 |
| UQ819 | MHM-8MM | 8* | Magnetic | 31.8 | 26.34 |
| UQ820 | MHM-10MM | 10* | Magnetic | 31.8 | 67.69 |

* Insert bits

1/4" HEX TO MALE SQUARE DRIVES



| Model No. | Mfg. No. | Square Size" | Lock Type | Overall Length" | Price /Each |
|-----------|------------|--------------|-----------|-----------------|-------------|
| UQ821 | EX-250 | 1/4 | Pin | 1.38 | 12.31 |
| UQ822 | EX-250-B | 1/4 | Ball | 1.38 | 14.39 |
| UQ823 | EX-250-2 | 1/4 | Pin | 2.00 | 12.25 |
| UQ824 | EX-250-B-2 | 1/4 | Ball | 2.00 | 12.98 |
| UQ825 | EX-250-4 | 1/4 | Pin | 4.00 | 13.80 |
| UQ826 | EX-250-B-4 | 1/4 | Ball | 4.00 | 14.54 |
| UQ827 | EX-250-6 | 1/4 | Pin | 6.00 | 17.00 |
| UQ828 | EX-250-B-6 | 1/4 | Ball | 6.00 | 18.91 |
| UQ829 | EX-370 | 3/8 | Pin | 1.38 | 14.01 |
| UQ830 | EX-370-B | 3/8 | Ball | 1.38 | 14.74 |
| UQ831 | EX-370-2 | 3/8 | Pin | 2.00 | 14.07 |
| UQ832 | EX-370-B-2 | 3/8 | Ball | 2.00 | 14.63 |
| UQ833 | EX-370-4 | 3/8 | Pin | 4.00 | 15.57 |
| UQ834 | EX-370-B-4 | 3/8 | Ball | 4.00 | 16.98 |
| UQ835 | EX-370-6 | 3/8 | Pin | 6.00 | 17.09 |
| UQ836 | EX-370-B-6 | 3/8 | Ball | 6.00 | 20.50 |
| UQ837 | EX-500-2 | 1/2 | Pin | 2.00 | 34.83 |
| UQ838 | EX-500-B-2 | 1/2 | Ball | 2.00 | 34.83 |
| UQ839 | EX-500-4 | 1/2 | Pin | 4.00 | 64.17 |
| UQ840 | EX-500-B-4 | 1/2 | Ball | 4.00 | 64.17 |
| UQ841 | EX-500-6 | 1/2 | Pin | 6.00 | 99.12 |

1/4" MAGNETIC BIT HOLDERS



| Model No. | Mfg. No. | Overall Length" | Price/Each |
|-----------|----------|-----------------|------------|
| UQ850 | M-490-2 | 2.00 | 22.03 |
| UQ851 | M-490 | 2.97 | 19.77 |
| UQ852 | M-497 | 3.09 | 31.63 |
| UQ853 | M-490-4 | 4.00 | 37.83 |
| UQ854 | M-490-6 | 6.00 | 40.53 |
| UQ855 | M-490-8 | 8.00 | 51.10 |
| UQ856 | M-490-10 | 10.00 | 55.80 |
| UQ857 | M-490-12 | 12.00 | 79.00 |

SCREWDRIVERS, INSERT BITS & HEX KEYS

1/4" SQUARE TURNED-BODY POWER BITS



| Model No. | Mfg. No. | Point Size | Overall Length" | Turned Length" | Price /Each |
|-----------|----------|------------|-----------------|----------------|-------------|
| UQ539 | 1950-0 | 0 | 1.94 | 1.25 | 15.80 |
| UQ540 | 1951-0 | 0 | 2.75 | 2.00 | 15.10 |
| UQ542 | 1950-1 | 1 | 1.94 | 1.25 | 4.49 |
| UQ543 | 1951-1 | 1 | 2.75 | 2.00 | 5.02 |
| UQ544 | 1953-1 | 1 | 3.50 | 2.75 | 5.43 |
| UQ545 | 1950-2X | 2 | 1.94 | 1.25 | 3.99 |
| UQ546 | 1951-2 | 2 | 2.75 | 2.00 | 4.41 |
| UQ547 | 1953-2 | 2 | 3.50 | 2.75 | 4.82 |
| UQ548 | 1950-3 | 3 | 1.94 | 1.25 | 6.40 |
| UQ549 | 1951-3 | 3 | 2.75 | 2.00 | 7.75 |
| UQ550 | 1953-3 | 3 | 3.50 | 2.75 | 5.84 |

1/4" METRIC HEX POWER BITS



| Model No. | Mfg. No. | Point Size mm | Overall Length" | Price /Each |
|-----------|----------|---------------|-----------------|-------------|
| UQ667 | AM-1.5MM | 1.5 | 1.94 | 11.48 |
| UQ668 | AM-2MM | 2 | 1.94 | 11.40 |
| UQ669 | AM-2.5MM | 2.5 | 1.94 | 11.37 |
| UQ670 | AM-3MM | 3 | 1.94 | 11.45 |
| UQ671 | AM-3MM-3 | 3 | 3.00 | 42.79 |
| UQ672 | AM-3MM-4 | 3 | 4.00 | 45.67 |
| UQ673 | AM-4MM | 4 | 1.94 | 11.40 |
| UQ674 | AM-5MM | 5 | 1.94 | 11.40 |
| UQ675 | AM-5MM-4 | 5 | 4.00 | 54.63 |
| UQ676 | AM-6MM | 6 | 1.94 | 11.40 |
| UQ677 | AM-6MM-4 | 6 | 4.00 | 45.67 |
| UQ678 | AM-7MM | 7 | 1.94 | 11.45 |
| UQ679 | AM-8MM | 8 | 1.94 | 11.48 |
| UQ680 | AM-10MM | 10 | 1.94 | 11.95 |

1/4" SAE HEX POWER BITS



| Model No. | Mfg. No. | Point Size | Overall Length" | Price /Each |
|-----------|----------|------------|-----------------|-------------|
| UQ681 | AM-02 | 1/16 | 1.94 | 9.43 |
| UQ682 | AM-02-A | 5/64 | 1.94 | 9.49 |
| UQ683 | AM-03 | 3/32 | 1.94 | 9.46 |
| UQ684 | AM-03-3 | 3/32 | 3.00 | 42.79 |
| UQ685 | AM-03-6 | 3/32 | 6.00 | 52.86 |
| UQ686 | AM-03-A | 7/64 | 1.94 | 9.46 |
| UQ687 | AM-04 | 1/8 | 1.94 | 9.07 |
| UQ688 | AM-04-3 | 1/8 | 3.00 | 42.79 |
| UQ689 | AM-04-35 | 1/8 | 3.50 | 44.05 |
| UQ690 | AM-04-4 | 1/8 | 4.00 | 44.20 |
| UQ692 | AM-04-6 | 1/8 | 6.00 | 48.02 |
| UQ693 | AM-04-A | 9/64 | 1.94 | 9.16 |
| UQ695 | AM-05 | 5/32 | 1.94 | 9.05 |
| UQ696 | AM-05-3 | 5/32 | 3.00 | 42.61 |
| UQ698 | AM-05-4 | 5/32 | 4.00 | 45.23 |
| UQ699 | AM-05-5 | 5/32 | 5.00 | 53.16 |
| UQ700 | AM-05-6 | 5/32 | 6.00 | 53.45 |
| UQ701 | AM-05-8 | 5/32 | 8.00 | 64.17 |
| UQ702 | AM-06 | 3/16 | 1.94 | 9.07 |
| UQ703 | AM-06-3 | 3/16 | 3.00 | 42.79 |
| UQ704 | AM-06-4 | 3/16 | 4.00 | 45.82 |
| UQ705 | AM-06-6 | 3/16 | 6.00 | 53.30 |
| UQ706 | AM-07 | 7/32 | 1.94 | 9.52 |
| UQ707 | AM-08 | 1/4 | 1.94 | 9.22 |
| UQ708 | AM-10 | 5/16 | 1.94 | 9.52 |

1/4" SLOT POWER BITS



| Model No. | Mfg. No. | Screw Size | Blade Overall Length" | /Body Width" | Price /Each |
|-----------|----------|------------|-----------------------|--------------|-------------|
| UQ572 | 320-000X | 1F-2R | 1.94 | 0.122 | 5.17 |
| UQ573 | 326-000X | 1F-2R | 2.75 | 0.122 | 15.42 |
| UQ574 | 323-000X | 1F-2R | 3.00 | 0.122 | 13.72 |
| UQ575 | 327-000X | 1F-2R | 3.50 | 0.122 | 12.95 |
| UQ576 | 324-000X | 1F-2R | 4.00 | 0.122 | 12.78 |
| UQ577 | 325-000X | 1F-2R | 5.00 | 0.122 | 15.45 |
| UQ578 | 328-000X | 1F-2R | 6.00 | 0.122 | 15.77 |
| UQ579 | 320-00X | 2F-3R | 1.94 | 0.134 | 5.23 |
| UQ580 | 326-00X | 2F-3R | 2.75 | 0.134 | 6.14 |
| UQ581 | 323-00X | 2F-3R | 3.00 | 0.134 | 6.78 |
| UQ583 | 324-00X | 2F-3R | 4.00 | 0.134 | 13.69 |
| UQ584 | 325-00X | 2F-3R | 5.00 | 0.134 | 14.66 |
| UQ585 | 328-00X | 2F-3R | 6.00 | 0.134 | 15.77 |
| UQ586 | 320-0X | 3F-4R | 1.94 | 0.151 | 5.05 |
| UQ587 | 326-0X | 3F-4R | 2.75 | 0.151 | 6.81 |
| UQ588 | 323-0X | 3F-4R | 3.00 | 0.151 | 7.25 |
| UQ589 | 327-0X | 3F-4R | 3.50 | 0.151 | 13.07 |
| UQ590 | 324-0X | 3F-4R | 4.00 | 0.151 | 13.63 |
| UQ592 | 328-0X | 3F-4R | 6.00 | 0.151 | 15.68 |
| UQ593 | 320-1X | 4F-5R | 1.94 | 0.187 | 4.58 |
| UQ594 | 326-1X | 4F-5R | 2.75 | 0.187 | 6.75 |
| UQ595 | 323-1X | 4F-5R | 3.00 | 0.187 | 6.46 |
| UQ596 | 327-1X | 4F-5R | 3.50 | 0.187 | 6.40 |
| UQ597 | 324-1X | 4F-5R | 4.00 | 0.187 | 13.95 |
| UQ598 | 325-1 | 4F-5R | 5.00 | 0.187 | 9.69 |
| UQ599 | 328-1X | 4F-5R | 6.00 | 0.187 | 14.33 |
| UQ600 | 320-20X | 5F-6R | 1.94 | 0.215 | 6.14 |
| UQ601 | 326-20X | 5F-6R | 2.75 | 0.215 | 6.87 |
| UQ602 | 323-20X | 5F-6R | 3.00 | 0.215 | 6.55 |
| UQ603 | 327-20X | 5F-6R | 3.50 | 0.215 | 6.96 |
| UQ604 | 324-20X | 5F-6R | 4.00 | 0.215 | 8.08 |
| UQ605 | 325-20X | 5F-6R | 5.00 | 0.215 | 14.71 |
| UQ606 | 328-20X | 5F-6R | 6.00 | 0.215 | 15.07 |

1/4" SAE HEX INSERT BITS



| Model No. | Mfg. No. | Point Size | Overall Length" | Price /Each |
|-----------|----------|------------|-----------------|-------------|
| UQ653 | 185-000X | 0.050 | 1.00 | 13.74 |
| UQ654 | 185-00X | 1/16 | 1.00 | 5.76 |
| UQ655 | 185-0X | 5/64 | 1.00 | 4.82 |
| UQ656 | 185-1X | 3/32 | 1.00 | 4.82 |
| UQ657 | 185-9X | 7/64 | 1.00 | 5.46 |
| UQ658 | 185-2X | 1/8 | 1.00 | 4.46 |
| UQ659 | 185-10X | 9/64 | 1.00 | 4.70 |
| UQ660 | 185-3X | 5/32 | 1.31 | 4.46 |
| UQ661 | 185-4X | 3/16 | 1.31 | 4.70 |
| UQ662 | 185-4-4X | 3/16 | 4.00 | 20.53 |
| UQ663 | 185-5X | 7/32 | 1.31 | 5.79 |
| UQ664 | 185-6X | 1/4 | 1.31 | 4.85 |
| UQ665 | 185-7X | 5/16 | 1.25 | 8.81 |
| UQ666 | 185-8X | 3/8 | 1.25 | 7.64 |

1/4" METRIC HEX INSERT BITS



| Model No. | Mfg. No. | Point Size | Overall Length" | Price /Each |
|-----------|-----------|------------|-----------------|-------------|
| UQ642 | 185-1.5MM | 1.5 | 1.00 | 8.08 |
| UQ643 | 185-2MM | 2 | 1.00 | 6.43 |
| UQ644 | 185-2.5MM | 2.5 | 1.00 | 6.46 |
| UQ645 | 185-3MM | 3 | 1.00 | 5.08 |
| UQ646 | 185-4MM | 4 | 1.31 | 5.08 |
| UQ647 | 185-5MM | 5 | 1.31 | 5.14 |
| UQ648 | 185-6MM | 6 | 1.31 | 5.14 |
| UQ649 | 185-7MM | 7 | 1.25 | 7.69 |
| UQ650 | 185-8MM | 8 | 1.25 | 9.43 |
| UQ651 | 185-9MM | 9 | 1.25 | 18.47 |
| UQ652 | 185-10MM | 10 | 1.25 | 12.07 |

1/4" TORX® INSERT BITS



| Model No. | Mfg. No. | Point Size | Overall Length" | Price /Each |
|-----------|-------------|------------|-----------------|-------------|
| UQ727 | 440-TX-05 | T-5 | 1.00 | 17.24 |
| UQ728 | 440-TX-06 | T-6 | 1.00 | 8.96 |
| UQ729 | 440-TX-07 | T-7 | 1.00 | 6.05 |
| UQ730 | 440-TX-08 | T-8 | 1.00 | 4.88 |
| UQ731 | 440-TX-09 | T-9 | 1.00 | 4.88 |
| UQ732 | 440-TX-10 | T-10 | 1.00 | 4.88 |
| UQ733 | 440-TX-15 | T-15 | 1.00 | 4.88 |
| UQ735 | 440-TX-20 | T-20 | 1.00 | 4.88 |
| UQ737 | 440-TX-20-2 | T-20 | 2.00 | 15.07 |
| UQ738 | 440-TX-25 | T-25 | 1.00 | 4.88 |
| UQ739 | 440-TX-27 | T-27 | 1.00 | 4.88 |
| UQ740 | 440-TX-30 | T-30 | 1.00 | 4.88 |
| UQ741 | 440-TX-40 | T-40 | 1.00 | 4.88 |
| UQ742 | 440-TX-45 | T-45 | 1.25 | 7.46 |
| UQ743 | 440-TX-50 | T-50 | 1.25 | 10.66 |

1/4" TRI-WING INSERT BITS



| Model No. | Mfg. No. | Point Size | Overall Length" | Price /Each |
|-----------|----------|------------|-----------------|-------------|
| UQ719 | TWD-0 | 0 | 1.00 | 11.89 |
| UQ720 | TWD-1 | 1 | 1.00 | 11.89 |
| UQ721 | TWD-2 | 2 | 1.00 | 11.81 |
| UQ722 | TWD-3 | 3 | 1.00 | 11.81 |
| UQ723 | TWD-4 | 4 | 1.00 | 11.84 |
| UQ724 | TWD-5 | 5 | 1.00 | 11.81 |
| UQ725 | TWD-6 | 6 | 1.00 | 24.41 |
| UQ726 | TWD-7 | 7 | 1.00 | 30.69 |

SCREWDRIVERS, INSERT BITS & HEX KEYS

1/4" PHILLIPS INSERT BITS



APEX

| Model No. | Mfg. No. | Point Size | Overall Length" | Price /Each |
|-----------|-----------|------------|-----------------|-------------|
| UQ420 | 440-1X | 1 | 1.00 | 1.38 |
| UQ421 | 440-115X | 1 | 1.50 | 4.02 |
| UQ422 | 440-12X | 1 | 2.00 | 3.88 |
| UQ423 | 440-125X | 1 | 2.50 | 5.05 |
| UQ425 | 440-2X | 2 | 1.00 | 1.23 |
| UQ427 | 440-215X | 2 | 1.50 | 2.53 |
| UQ428 | 440-22X | 2 | 2.00 | 3.20 |
| UQ429 | 440-225X | 2 | 2.50 | 4.67 |
| UQ430 | 440-23X | 2 | 3.00 | 6.67 |
| UQ431 | 440-24X | 2 | 4.00 | 7.02 |
| UQ433 | 440-26X | 2 | 6.00 | 13.36 |
| UQ434 | 440-3X | 3 | 1.00 | 1.26 |
| UQ435 | 440-3125X | 3 | 1.25 | 4.26 |
| UQ436 | 440-3BNX | 3* | 1.25 | 8.25 |
| UQ437 | 440-32X | 3 | 2.00 | 7.20 |
| UQ438 | 440-325X | 3 | 2.50 | 5.46 |
| UQ439 | 440-33X | 3 | 3.00 | 7.02 |
| UQ440 | 440-34X | 3 | 4.00 | 7.34 |
| UQ441 | 440-4X | 4 | 1.31 | 5.29 |

* Large body

1/4" PHILLIPS INSERT BITS, LIMITED CLEARANCE



APEX

| Model No. | Mfg. No. | Point Size | Overall Length" | Turned Length" | Price /Each |
|-----------|----------|------------|-----------------|----------------|-------------|
| UQ442 | 446-0X | 0 | 1.00 | 0.44 | 3.20 |
| UQ443 | 446-1X | 1 | 1.00 | 0.44 | 1.50 |
| UQ444 | 446-12X | 1 | 2.00 | 0.44 | 4.49 |
| UQ446 | 446-2X | 2 | 1.00 | 0.44 | 1.29 |
| UQ447 | 446-27X | 2 | 1.00 | 0.44 | 7.11 |
| UQ448 | 446-215X | 2 | 1.50 | 0.44 | 4.61 |
| UQ449 | 446-22X | 2 | 2.00 | 0.44 | 3.99 |
| UQ450 | 446-215T | 2 | 1.50 | 1.00 | 4.85 |
| UQ451 | 446-221X | 2 | 2.00 | 1.50 | 5.46 |
| UQ452 | 446-225T | 2 | 2.50 | 1.75 | 6.23 |
| UQ453 | 446-23T | 2 | 3.00 | 2.25 | 7.34 |

1/4" SQUARE RECESS INSERT BITS



APEX

| Model No. | Mfg. No. | Point Size | Overall Length" | Price /Each |
|-----------|----------|------------|-----------------|-------------|
| UQ519 | 950-0X | 0 | 1.00 | 3.67 |
| UQ520 | 950-1X | 1 | 1.00 | 3.49 |
| UQ521 | 950-2X | 2 | 1.00 | 1.59 |
| UQ522 | 950-3X | 3 | 1.00 | 3.32 |

1/4" SLOT INSERT BITS, LIMITED CLEARANCE



APEX

| Model No. | Mfg. No. | Screw Size | Overall Length" | Blade Width" | Price /Each |
|-----------|------------|------------|-----------------|--------------|-------------|
| UQ561 | 445-000X | 1F-2R | 1.00 | 0.125 | 5.79 |
| UQ562 | 445-00X | 2F-3R | 1.00 | 0.140 | 5.49 |
| UQ563 | 445-0X | 3F-4R | 1.00 | 0.154 | 5.52 |
| UQ564 | 445-10X | 4F-5R | 1.00 | 0.185 | 5.02 |
| UQ565 | 445-20X | 5F-6R | 1.00 | 0.216 | 5.26 |
| UQ566 | 445-30X | 6F-7R | 1.00 | 0.248 | 5.02 |
| UQ567 | 445-00-15X | 2F-3R | 1.50 | 0.138 | 6.61 |
| UQ568 | 445-0-15X | 3F-4R | 1.50 | 0.154 | 5.79 |
| UQ570 | 445-20-15X | 5F-6R | 1.50 | 0.216 | 6.70 |
| UQ571 | 445-30-15X | 6F-7R | 1.50 | 0.248 | 8.40 |

1/4" PHILLIPS POWER DRIVES, ACR



APEX

| Model No. | Mfg. No. | Point Size | Overall Length" | Turned Length" | Price /Each |
|-----------|---------------|------------|-----------------|----------------|-------------|
| UQ866 | 491-ACR1X | 1 | 1.94 | 1.25 | 5.35 |
| UQ867 | 492-ACR2-RX | 2 | 1.94 | 1.25 | 3.29 |
| UQ868 | 492-ACR2-DX | 2 | 1.94 | 1.25 | 3.82 |
| UQ869 | 492-ACR2X | 2 | 1.94 | 1.25 | 3.08 |
| UQ871 | 492-A-ACR2-DX | 2 | 2.75 | 2.00 | 3.94 |
| UQ872 | 492-A-ACR2X | 2 | 2.75 | 2.00 | 3.79 |
| UQ874 | 492-B-ACR2-DX | 2 | 3.50 | 2.75 | 7.22 |
| UQ875 | 492-B-ACR2X | 2 | 3.50 | 2.75 | 4.73 |
| UQ878 | 493-ACR3X | 3 | 1.94 | 1.00 | 5.79 |

1/4" PHILLIPS POWER DRIVES



APEX

| Model No. | Mfg. No. | Point Size | Overall Length" | Turned Length" | Price /Each |
|-----------|-------------|------------|-----------------|----------------|-------------|
| UQ475 | 4910X | 0 | 1.94 | 1.25 | 5.08 |
| UQ476 | 4910-AX | 0 | 2.75 | 2.00 | 7.25 |
| UQ477 | 4910-BX | 0 | 3.50 | 2.75 | 12.51 |
| UQ478 | 4910-CX | 0 | 6.00 | 2.00 | 15.62 |
| UQ479 | 491X | 1 | 1.94 | 1.25 | 2.88 |
| UQ480 | 491-AX | 1 | 2.75 | 2.00 | 3.20 |
| UQ481 | 491-BX | 1 | 3.50 | 2.75 | 3.94 |
| UQ482 | 491-CX | 1 | 6.00 | 2.00 | 7.87 |
| UQ483 | 491-CCX | 1 | 6.00 | 5.25 | 19.71 |
| UQ484 | 492X | 2 | 1.94 | 1.25 | 2.06 |
| UQ485 | 492-AX | 2 | 2.75 | 2.00 | 2.44 |
| UQ486 | 492-BX | 2 | 3.50 | 2.75 | 2.94 |
| UQ487 | 492-CX | 2 | 6.00 | 2.00 | 6.90 |
| UQ488 | 492-CCX | 2 | 6.00 | 5.25 | 10.78 |
| UQ489 | 492-27X* | 2 | 1.94 | 1.25 | 4.93 |
| UQ490 | 492-A-27X* | 2 | 2.75 | 2.00 | 6.78 |
| UQ491 | 492-B-27X* | 2 | 3.50 | 2.75 | 9.22 |
| UQ492 | 492-C-27X* | 2 | 6.00 | 2.00 | 8.49 |
| UQ493 | 492-CC-27X* | 2 | 6.00 | 5.25 | 23.14 |
| UQ494 | 492-200MM | 2 | 7.81 | 7.00 | 53.16 |
| UQ495 | SD-2052-8 | 2 | 8.00 | 7.00 | 19.44 |
| UQ496 | SD-2052-10 | 2 | 10.00 | 9.00 | 26.05 |
| UQ497 | 493X | 3 | 1.94 | 1.00 | 4.26 |
| UQ498 | 493-AX | 3 | 2.75 | 1.75 | 4.70 |
| UQ499 | 493-BX | 3 | 3.50 | 2.50 | 5.37 |
| UQ500 | 493-CX | 3 | 6.00 | 5.00 | 7.67 |
| UQ501 | 4930X | 3 | 1.94 | 1.25 | 5.84 |
| UQ502 | 4930-AX | 3 | 2.75 | 2.00 | 5.55 |
| UQ503 | 4930-BX | 3 | 3.50 | 2.75 | 6.64 |
| UQ504 | 4930-CX | 3 | 6.00 | 2.00 | 7.58 |
| UQ505 | 4930-CCX | 3 | 6.00 | 5.25 | 22.70 |
| UQ506 | 494X | 4 | 1.94 | 1.00 | 33.33 |

* For shallow recess screws

1/4" PHILLIPS BITS, ACR



APEX

| Model No. | Mfg. No. | Point Size | Overall Length" | Type | Price /Each |
|-----------|----------------|------------|-----------------|---------|-------------|
| UQ454 | 440-1-ACR1-RX | 1 | 1.00 | Removal | 2.17 |
| UQ455 | 440-1-ACR1-DX | 1 | 1.00 | Driving | 2.20 |
| UQ456 | 440-1-ACR1X | 1 | 1.00 | Both | 1.91 |
| UQ457 | 440-2-ACR2-RX | 2 | 1.00 | Removal | 1.91 |
| UQ458 | 440-2-ACR2-DX | 2 | 1.00 | Driving | 1.88 |
| UQ459 | 440-2-ACR2X | 2 | 1.00 | Both | 1.79 |
| UQ460 | 446-2-ACR2-DX | 2* | 1.00 | Driving | 3.38 |
| UQ461 | 440-22-ACR2-RX | 2 | 2.00 | Removal | 5.82 |
| UQ463 | 440-22-ACR2X | 2 | 2.00 | Both | 5.55 |
| UQ464 | 440-3-ACR3-RX | 3 | 1.00 | Removal | 2.26 |
| UQ465 | 440-3-ACR3-DX | 3 | 1.00 | Driving | 2.09 |
| UQ466 | 440-3-ACR3X | 3 | 1.00 | Both | 2.09 |

* Limited clearance

1/4" POSIDRIV® INSERT BITS



APEX

| Model No. | Mfg. No. | Point Size | Overall Length" | Price /Each |
|-----------|--------------|------------|-----------------|-------------|
| UQ467 | 440-1-PZDX | 1 | 1.00 | 5.35 |
| UQ469 | 440-2-PZDX | 2 | 1.00 | 1.50 |
| UQ470 | 440-215-PZDX | 2 | 1.50 | 6.84 |
| UQ471 | 440-22-PZDX | 2 | 2.00 | 4.90 |
| UQ473 | 440-3-PZDX | 3 | 1.00 | 2.38 |
| UQ474 | 440-4-PZDX | 4 | 1.25 | 9.16 |

1/4" POSIDRIV® POWER DRIVE BITS



APEX

| Model No. | Mfg. No. | Point Size | Overall Length" | Turned Length" | Price /Each |
|-----------|------------|------------|-----------------|----------------|-------------|
| UQ507 | 491-PZDX | 1 | 1.94 | 1.25 | 4.88 |
| UQ508 | 491-A-PZDX | 1 | 2.75 | 2.00 | 8.63 |
| UQ509 | 491-B-PZDX | 1 | 3.50 | 2.75 | 7.05 |
| UQ510 | 491-C-PZDX | 1 | 6.00 | 2.00 | 13.04 |
| UQ511 | 492-PZDX | 2 | 1.94 | 1.25 | 2.67 |
| UQ512 | 492-A-PZDX | 2 | 2.75 | 2.00 | 3.32 |
| UQ513 | 492-B-PZDX | 2 | 3.50 | 2.75 | 3.73 |
| UQ514 | 492-C-PZDX | 2 | 6.00 | 2.00 | 8.25 |
| UQ515 | 493-PZDX | 3 | 1.94 | 1.00 | 7.37 |
| UQ516 | 493-A-PZDX | 3 | 2.75 | 1.75 | 7.72 |
| UQ517 | 493-B-PZDX | 3 | 3.50 | 2.25 | 8.81 |
| UQ518 | 493-C-PZDX | 3 | 6.00 | 5.00 | 11.48 |

1/4" SLOT INSERT BITS



APEX

| Model No. | Mfg. No. | Screw Size | Overall Length" | Turned Length" | Price /Each |
|-----------|-----------|------------|-----------------|----------------|-------------|
| UQ551 | 445-1X | 4F-5R | 1.00 | 3/16 | 2.88 |
| UQ552 | 445-2X | 6F-8R | 1.00 | 7/32 | 2.88 |
| UQ553 | 445-3X | 8F-10R | 1.00 | 1/4 | 2.88 |
| UQ554 | 445-4X | 10F-12R | 1.00 | 9/32 | 4.11 |
| UQ555 | 445-1-15X | 4F-5R | 1.50 | 3/16 | 4.82 |
| UQ556 | 445-2-15X | 6F-8R | 1.50 | 7/32 | 4.46 |
| UQ557 | 445-3-15X | 8F-10R | 1.50 | 1/4 | 4.23 |
| UQ558 | 445-4-15X | 10F-12R | 1.50 | 9/32 | 4.46 |
| UQ559 | 445-5X | 12F-14R | 1.50 | 5/16 | 9.54 |
| UQ560 | 445-6X | 14F-16R | 1.50 | 23/64 | 10.01 |

1/4" SQUARE RECESS POWER BITS



APEX

| Model No. | Mfg. No. | Point Size | Overall Length" | Price /Each |
|-----------|----------|------------|-----------------|-------------|
| UQ523 | 954-0X | 0 | 1.94 | 4.38 |
| UQ524 | 954-A-0X | 0 | 2.75 | 7.90 |
| UQ526 | 954-C-0X | 0 | 6.00 | 21.97 |
| UQ527 | 954-1X | 1 | 1.94 | 2.73 |
| UQ528 | 954-A-1X | 1 | 2.75 | 3.26 |
| UQ529 | 954-B-1X | 1 | 3.50 | 4.41 |
| UQ530 | 954-C-1X | 1 | 6.00 | 6.61 |
| UQ531 | 954-2X | 2 | 1.94 | 2.53 |
| UQ532 | 954-A-2X | 2 | 2.75 | 2.91 |
| UQ533 | 954-B-2X | 2 | 3.50 | 3.99 |
| UQ534 | 954-C-2X | 2 | 6.00 | 7.81 |
| UQ535 | 954-3X | 3 | 1.94 | 2.73 |
| UQ536 | 954-A-3X | 3 | 2.75 | 3.26 |
| UQ537 | 954-B-3X | 3 | 3.50 | 4.49 |
| UQ538 | 954-C-3X | 3 | 6.00 | 6.61 |

SCREWDRIVERS, INSERT BITS & HEX KEYS



A. Short



TDS405

A. Long



TDS423

B. Short



TDS293

B. Long



TDS320

C.

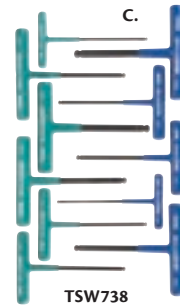

TSW738

D.

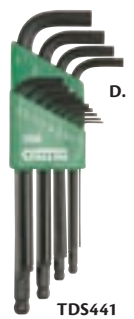

TDS441

A. SHORT & LONG ARM SETS

With plastic holder.



| Model No. | Mfg. No. | No. of Keys | Key Sizes" | Price /Each |
|---------------------------|----------|-------------|--|-------------|
| SAE - SHORT ARM | | | | |
| TDS405 | 56080 | 13 | 0.050, 1/16, 5/64, 3/32, 7/64, 1/8, 9/64, 5/32, 3/16, 7/32, 1/4, 5/16, 3/8 | 19.80 |
| TDS481 | 56108 | 12 | 0.050, 1/16, 5/64, 3/32, 7/64, 1/8, 9/64, 5/32, 3/16, 7/32, 1/4, 5/16 | 11.30 |
| SAE - LONG ARM | | | | |
| TDS423 | 56152 | 12 | 0.050, 1/16, 5/64, 3/32, 7/64, 1/8, 9/64, 5/32, 3/16, 7/32, 1/4, 5/16 | 17.20 |
| QN289 | 56081 | 13 | 0.050, 1/16, 5/64, 3/32, 7/64, 1/8, 9/64, 5/32, 3/16, 7/32, 1/4, 5/16, 3/8 | 27.50 |
| METRIC - SHORT ARM | | | | |
| Key Sizes (mm) | | | | |
| TDS460 | 56008 | 9 | 1.5, 2, 2.5, 3, 4, 5, 6, 8, 10 | 13.20 |
| METRIC - LONG ARM | | | | |
| TDS401 | 56149 | 9 | 1.5, 2, 2.5, 3, 4, 5, 6, 8, 10 | 20.30 |

C. BALL PLUS™ CUSHION GRIP T-HANDLE SETS



| Model No. | Mfg. No. | No. of Keys | Key Sizes" | Key Sizes (mm) | Price /Each |
|---------------|----------|-------------|---|----------------|-------------|
| QN276 | 56130 | 10 | 3/32", 7/64", 1/8, 9/64, 5/32, 3/16, 7/32, 1/4, 5/16, 3/8 | | 79.90 |
| TSW738 | 56134 | 11 | 5/32, 3/16, 7/32, 1/4, 5/16, 3/8 | 4, 5, 6, 8, 10 | 110.00 |
| METRIC | | | | | |
| QN275 | 56132 | 7 | 2.5*, 3, 4, 5, 6, 8, 10 | | 61.50 |

*Hex end only

B. SHORT & LONG ARM SETS

With metal box.



| Model No. | Mfg. No. | No. of Keys | Key Sizes" | Price /Each |
|---------------------------|----------|-------------|--|-------------|
| SAE - SHORT ARM | | | | |
| TDS320 | 56028 | 15 | 0.028, 0.035, 0.050, 1/16, 5/64, 3/32, 7/64, 1/8, 9/64, 5/32, 3/16, 7/32, 1/4, 5/16, 3/8 | 36.20 |
| TDS293 | 56026 | 18 | 0.028, 0.035, 0.050, 1/16, 5/64, 3/32, 7/64, 1/8, 9/64, 5/32, 3/16, 7/32, 1/4, 5/16, 3/8, 1/2, 9/16, 5/8 | 63.60 |
| METRIC - LONG ARM | | | | |
| Key Sizes (mm) | | | | |
| TDS328 | 56085 | 10 | 1.5, 2, 2.5, 3, 4, 5, 6, 8, 10, 12 | 32.70 |
| METRIC - SHORT ARM | | | | |
| TDS317 | 56038 | 12 | 0.7, 0.9, 1.3, 1.5, 2, 2.5, 3, 4, 5, 6, 8, 10 | 40.70 |
| TDS287 | 56036 | 15 | 0.7, 0.9, 1.3, 1.5, 2, 2.5, 3, 4, 5, 6, 8, 10, 12, 14, 17 | 68.40 |

D. BALL PLUS™ SETS



| Model No. | Mfg. No. | No. of Keys | Key Sizes" | Price /Each | |
|------------------------------------|----------|-------------|--|---------------------------|-------------|
| FRACTIONAL | | | | | |
| QN274 | 56190 | 13 | 0.050, 1/16, 5/64, 3/32, 7/64, 1/8, 9/64, 5/32, 3/16, 7/32, 1/4, 5/16, 3/8 | 28.80 | |
| TDS362 | 59901 | 13 | 0.050, 1/16, 5/64, 3/32, 7/64, 1/8, 9/64, 5/32, 3/16, 7/32, 1/4, 5/16, 3/8 | 34.10 | |
| TDS391 | 56196 | 12 | 0.050, 1/16, 5/64, 3/32, 7/64, 1/8, 9/64, 5/32, 3/16, 7/32, 1/4, 5/16 | 23.10 | |
| TDS441 | 56198 | 7 | 5/64, 3/32, 7/64, 1/8, 9/64, 5/32, 3/16 | 16.30 | |
| METRIC | | | | | |
| TDS383 | 59915 | 9 | 1.5, 2, 2.5, 3, 4, 5, 6, 8, 10 | 22.90 | |
| FRACTIONAL/METRIC COMBO SET | | | | | |
| Model No. | Mfg. No. | No. of Keys | Key Sizes" | Key Sizes (mm) | Price /Each |
| TDS307 | 59801 | 22 | 0.050, 1/16, 5/64, 3/32, 7/64, 1/8, 9/64, 5/32, 3/16, 7/32, 1/4, 5/16, 3/8 | 2, 2.5, 3, 4, 5, 6, 8, 10 | 52.20 |

HEX KEY POUCH SETS

- Chrome vanadium steel for strength and durability
- Tips are chamfered for ease of entry and proper fit

aurora tools®



| Model No. | No. of Keys | Key Sizes | Price /Each |
|---------------------------|-------------|--|-------------|
| SAE - SHORT ARM | | | |
| TNB731 | 13 | 1/20", 1/16", 5/64", 3/32", 7/64", 1/8", 9/64", 5/32", 3/16", 7/32", 1/4", 5/16", 3/8" | 10.10 |
| METRIC - SHORT ARM | | | |
| TNB732 | 9 | 1.5 mm, 2.0 mm, 2.5 mm, 3.0 mm, 4.0 mm, 5.0 mm, 6.0 mm, 8.0 mm, 10.0 mm | 8.15 |



TNB731

TNB732

SCREWDRIVERS, INSERT BITS & HEX KEYS

BALL END SCREWDRIVERS

- Corrosion-resistant finish and environmentally safe
- Ergonomically designed handles deliver maximum torque with unrivaled comfort and grip
- Up to 20% stronger, with more torque and twice the wear resistance of standard grades of steel



| SAE | | | | METRIC | | | | | |
|-----------|----------|------------|---------|-------------|-----------|----------|----------------|---------|-------------|
| Model No. | Mfg. No. | Key Sizes" | Length" | Price /Each | Model No. | Mfg. No. | Key Sizes (mm) | Length" | Price /Each |
| TLV452 | 10704 | 5/64 | 4.3 | 4.52 | TLV463 | 10752 | 2 | 4 | 4.59 |
| TLV453 | 10705 | 3/32 | 4.8 | 4.59 | TLV464 | 10754 | 2.5 | 4.8 | 4.94 |
| TLV454 | 10706 | 7/64 | 5.9 | 5.55 | TLV465 | 10756 | 3 | 6.2 | 5.84 |
| TLV455 | 10707 | 1/8 | 6.4 | 5.55 | TLV466 | 10760 | 4 | 7 | 6.28 |
| TLV456 | 10708 | 9/64 | 6.9 | 5.99 | TLV467 | 10764 | 5 | 7.8 | 8.59 |
| TLV457 | 10709 | 5/32 | 7.4 | 7.17 | TLV468 | 10768 | 6 | 8.6 | 9.22 |
| TLV458 | 10710 | 3/16 | 7.9 | 7.96 | TLV469 | 10772 | 8 | 9.3 | 12.80 |
| TLV459 | 10711 | 7/32 | 8.4 | 8.91 | TLV470 | 10776 | 10 | 10.2 | 15.70 |
| TLV460 | 10712 | 1/4 | 8.9 | 10.40 | - | - | - | - | - |
| TLV461 | 10713 | 5/16 | 9.5 | 12.30 | - | - | - | - | - |
| TLV462 | 10714 | 3/8 | 9.9 | 14.30 | - | - | - | - | - |

BALL END SCREWDRIVER SETS

- Corrosion-resistant finish and environmentally safe
- Mold-on rubber coating on handle for superior grip
- Handles shape prevents rolling on surfaces angled up to 15°
- Ergonomically designed handles deliver maximum torque with unrivaled comfort and grip
- Up to 20% stronger, with more torque and twice the wear resistance of standard grades of steel



| Model No. | Mfg. No. | No. of Keys | Key Sizes" | Price /Each |
|-----------|----------|-------------|--|-------------|
| SAE | | | | |
| TX399 | 10632 | 8 | 0.05, 1/16, 5/64, 3/32, 7/64, 1/8, 9/64, 5/32 | 29.90 |
| TX400 | 10633 | 8 | 7/16, 1/8, 9/64, 5/32, 3/16, 7/32, 1/4, 5/16 | 48.50 |
| TX401 | 10637 | 13 | .05, 1/16, 5/64, 3/32, 7/64, 1/8, 9/64, 5/32, 3/16, 7/32, 1/4, 5/16, 3/8 | 72.10 |
| TX402 | 10645 | 7 | 5/64, 3/32, 7/64, 1/8, 9/64, 5/32, 3/16 | 29.50 |
| METRIC | | | | |
| TX403 | 10686 | 6 | 1.5, 2, 2.5, 3, 4, 5 | 26.30 |
| TX404 | 10687 | 7 | 1.27, 1.5, 2, 2.5, 3, 4, 5 | 29.40 |
| TX405 | 10699 | 9 | 1.5, 2, 2.5, 3, 4, 5, 6, 8, 10 | 57.80 |

INDIVIDUAL T-HANDLE HEX KEYS

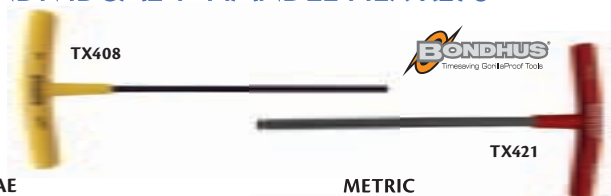

| SAE | | | | METRIC | | | |
|-----------|----------|-------|-------------|-----------|----------|-----------|-------------|
| Model No. | Mfg. No. | Size" | Price /Each | Model No. | Mfg. No. | Size (mm) | Price /Each |
| TX406 | 13205 | 3/32 | 5.65 | TX416 | 13254 | 2.5 | 6.37 |
| TX407 | 13206 | 7/64 | 5.99 | TX417 | 13256 | 3 | 6.72 |
| TX408 | 13207 | 1/8 | 6.37 | TX418* | 13160 | 4 | 7.52 |
| TX409 | 13208 | 9/64 | 6.72 | TX419* | 13164 | 5 | 8.64 |
| TX410* | 13109 | 5/32 | 7.17 | TX420* | 13168 | 6 | 9.41 |
| TX411* | 13110 | 3/16 | 7.52 | TX421* | 13172 | 8 | 14.10 |
| TX412* | 13111 | 7/32 | 8.87 | TX422* | 13176 | 10 | 15.50 |
| TX413* | 13112 | 1/4 | 9.12 | - | - | - | - |
| TX414* | 13113 | 5/16 | 13.90 | - | - | - | - |

* Ballpoint

DURACAST® FOLD-UPS



| Model No. | Mfg. No. | No. of Keys | Key Sizes" | Handle Length" | Price /Each |
|-----------|----------|-------------|--|----------------|-------------|
| SAE | | | | | |
| TDT380 | 56346 | 9 | 0.050, 1/16, 5/64, 3/32, 7/64, 1/8, 9/64, 5/32, 3/16 | 3 1/2 | 19.50 |
| UQ073 | 56347 | 9 | 5/64, 3/32, 7/64, 1/8, 9/64, 5/32, 3/16, 7/32, 1/4 | 4 1/4 | 21.50 |
| METRIC | | | | | |
| TDT371 | 56349 | 7 | 1.5, 2, 2.5, 3, 4, 5, 6 | 3 1/2 | 19.80 |
| TORX® | | | | | |
| TDT224 | 56348 | 7 | T-10, T-15, T-20, T-25, T-27, T-30, T-40 | 4 1/4 | 37.70 |

DURACAST® BALL END FOLD-UP



| Model No. | Mfg. No. | No. of Keys | Key Sizes" | Handle Length" | Price /Each |
|-----------|----------|-------------|--|----------------|-------------|
| TSW740 | 56382 | 9 | 5/64, 3/32, 7/64, 1/8, 9/64, 5/32, 3/16, 7/32, 1/4 | 4 1/4 | 35.20 |

STANDARD FOLD-UPS



| Model No. | Mfg. No. | No. of Keys | Handle Key Sizes" | Handle Length" | Price /Each |
|-----------|----------|-------------|--|----------------|-------------|
| SAE | | | | | |
| TDT616 | 56066 | 9 | 0.050, 1/16, 5/64, 3/32, 7/64, 1/8, 9/64, 5/32, 3/16 | 3 3/8 | 19.90 |
| METRIC | | | | | |
| QN269 | 56070 | 7 | 1.5, 2, 2.5, 3, 4, 5, 6 | 3 3/4 (95 mm) | 21.40 |

FOLDING HEX KEY SETS

- Chrome vanadium steel for strength and durability
- Tips are chamfered for ease of entry and proper fit
- Set folds securely into convenient storage compartment

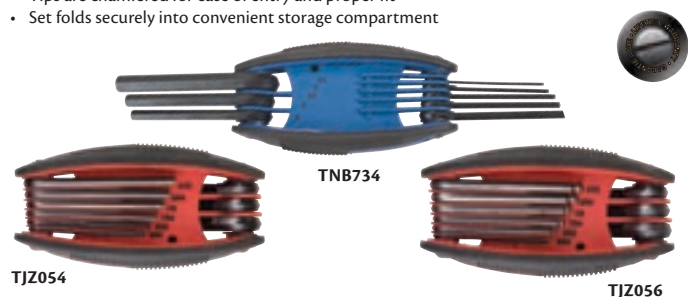

| Model No. | No. of Keys | Key Sizes | Price /Each |
|------------------------|-------------|--|-------------|
| SAE FOLD UP | | | |
| TJZ054 | 9 | 5/64", 3/32", 7/64", 1/8", 9/64", 5/32", 3/16", 7/32", 1/4" | 8.40 |
| METRIC FOLD UP | | | |
| TNB734 | 8 | 1.5 mm, 2.0 mm, 2.5 mm, 3.0 mm, 4.0 mm, 5.0 mm, 6.0 mm, 8.0 mm | 8.30 |
| SAE - BALL END FOLD UP | | | |
| TJZ056 | 9 | 5/64", 3/32", 7/64", 1/8", 9/64", 5/32", 3/16", 7/32", 1/4" | 9.80 |

PLIERS

SLIP JOINT PLIERS

- Sure gripping precision milled jaws
- Light and rugged drop-forged alloy steel
- Flush pivot design for use in tight spaces
- Length: 6 1/2"
- Meets ANSI standards

Model No. TJZ078
Price/Each \$8.95



aurora tools

SLIP JOINT PLIERS



| Model No. | Mfg. No. | Overall Length" | Price /Each |
|-----------|----------|-----------------|-------------|
| U0230 | 67-667 | 6.500 | 18.90 |
| U0231 | 67-669 | 8.000 | 22.80 |
| U0232 | 67-671 | 10.000 | 28.50 |

ARMSTRONG
INDUSTRIAL HAND TOOLS

DIAGONAL CUTTING PLIERS

- Precision tested jaws provide uniform cut
- Slim profile reaches into cramped quarters
- Black nickel finish resists rust
- Induction heat-treated cutting edge
- Smooth non-sticking lever mechanism
- Meets ANSI standards

| Model No. | Length" | Price/Each |
|-----------|---------|------------|
| TJZ082 | 5 | 8.95 |
| TJZ083 | 6 | 9.60 |
| TJZ084 | 7 | 11.60 |



aurora tools

DIAGONAL CUTTING PLIERS

- Precision machined cutting edges meet at the tip, providing improved cutting performance
- Induction hardened cutting edge ensures maximum durability and long life

| Model No. | Mfg. No. | Overall Length" | Price /Each |
|-----------|----------|-----------------|-------------|
| U0199 | 67-155 | 4.250 | 29.20 |
| U0200 | 67-159 | 5.125 | 29.90 |
| U0201 | 67-161 | 6.375 | 29.20 |
| U0202 | 67-163 | 7.438 | 32.20 |

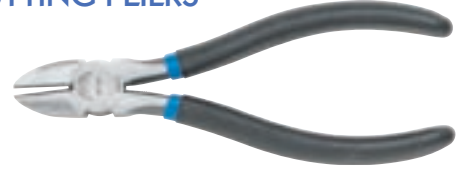

ARMSTRONG
INDUSTRIAL HAND TOOLS

LONG NOSE CUTTING PLIERS

- Strong sure gripping jaws manipulate wire and other awkward objects
- Slim tapered head extends reach and maintains visibility in small areas
- Black nickel finish resists rust
- Meets ANSI standards

| Model No. | Length" | Price/Each |
|-----------|---------|------------|
| TJZ085 | 5 | 8.60 |
| TJZ086 | 6 | 9.60 |
| TJZ087 | 8 | 11.10 |



aurora tools

LONG NOSE CUTTING PLIERS

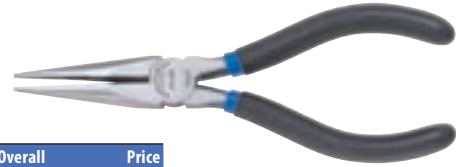

| Model No. | Mfg. No. | Overall Length" | Price /Each |
|-----------|----------|-----------------|-------------|
| U0208 | 67-253 | 4.750 | 27.20 |
| U0209 | 67-255 | 5.313 | 28.50 |
| U0210 | 67-257 | 6.313 | 29.90 |
| U0211 | 67-259 | 7.875 | 32.20 |

ARMSTRONG
INDUSTRIAL HAND TOOLS

GROOVE JOINT PLIERS

- Sure gripping precision milled jaws
- Grooves undercut and milled to prevent slipping when tightening
- Light and rugged drop-forged alloy steel
- Flush pivot design for use in tight spaces
- Meets ANSI standards

| Model No. | Length" | Price/Each |
|-----------|---------|------------|
| TJZ079 | 8 | 12.40 |
| TJZ080 | 10 | 15.40 |



aurora tools

GROOVE JOINT PLIERS

- Precision milled undercut rib joint provides positive interlock between the two halves, eliminating separation
- Angled teeth provide superior gripping power over standard teeth
- Specially designed fastener ensures permanent assembly and smooth operation

| Model No. | Mfg. No. | Overall Length" | Price /Each |
|-----------|----------|-----------------|-------------|
| U0237 | 67-717 | 5.000 | 23.60 |
| U0241 | 67-777 | 7.000 | 23.50 |
| U0242 | 67-779 | 10.000 | 27.30 |
| U0243 | 67-781 | 12.000 | 32.20 |
| U0244 | 67-783 | 16.000 | 49.10 |



ARMSTRONG
INDUSTRIAL HAND TOOLS

LINESMAN CUTTING PLIERS

- Precision milled jaw grip and hold wire without slipping
- Black nickel finish resists rust
- Meets ANSI standards

| Model No. | Length" | Price/Each |
|-----------|---------|------------|
| TJZ088 | 7 | 12.55 |
| TJZ089 | 8 | 13.50 |



aurora tools

LINESMAN CUTTING PLIERS

- Precision machined cutting edges meet at the hinge, providing improved cutting performance
- Induction hardened cutting edge ensures maximum durability and long life
- Diamond serrated jaws provides a firm grip

| Model No. | Mfg. No. | Overall Length" | Price /Each |
|-----------|----------|-----------------|-------------|
| U0191 | 67-063 | 6.438 | 41.80 |
| U0192 | 67-065 | 7.375 | 44.40 |
| U0193 | 67-067 | 8.375 | 46.50 |
| U0194 | 67-069 | 9.500 | 47.60 |



ARMSTRONG
INDUSTRIAL HAND TOOLS

SLIP-JOINT PLIERS

- Nickel-chrome plated finish
- Shear-type wire cutters
- Adjustable two-position jaws
- Plastic-dipped handles



| Model No. | Mfg. No. | Overall Length" | Price /Each |
|-----------|----------|-----------------|-------------|
| TJ912 | D511-6 | 6 9/16 | 26.60 |
| TJ913 | D511-8 | 8 1/16 | 33.60 |
| TJ914 | D511-10 | 9 7/8 | 44.10 |



GROOVE JOINT PLIERS

- Tongue and groove design
- Adjusts to fit within its maximum capacity
- Anti-slip jaws
- Plastic-dipped handles



| Model No. | Mfg. No. | Overall Length" | Maximum Capacity" | Price /Each |
|-----------|----------|-----------------|-------------------|-------------|
| TJ915 | D502-6 | 6 1/2 | 1 | 35.30 |
| TJ916 | D502-10 | 10 | 1 3/4 | 43.70 |
| TJ917 | D502-12 | 12 1/4 | 2 1/8 | 54.30 |
| TJ918 | D502-16 | 16 3/4 | 4 1/4 | 102.00 |



LONG REACH CHAIN NOSE PLIERS

Extra long handle allows greater access to confined, restricted areas and provides more holding power at the tip with less effort.



| Model No. | Mfg. No. | Overall Length" | Price /Each |
|-----------|----------|-----------------|-------------|
| TDR572 | 67-240 | 11.562 | 57.50 |



END CUTTING NIPPERS

For cutting wire and small nails close to the surface. The head is designed to provide maximum strength and leverage.



| Model No. | Mfg. No. | Overall Length" | Price /Each |
|-----------|----------|-----------------|-------------|
| TDQ424 | 406-1956 | 6 | 8.04 |



RATCHETING CABLE CUTTERS

- Cuts cable straight with minimum effort
- Cuts up to: 600 mcm aluminum (not ACSR), 400 mcm copper
- Quick release mechanism and hold open spring
- Plastic finger formed grips



| Model No. | Mfg. No. | Overall Length" | Price /Each |
|-----------|----------|-----------------|-------------|
| TJ953 | 63060 | 10 | 479.00 |



HIGH LEVERAGE SIDE CUTTERS

- Smooth, streamlined nose with knurled jaws
- High-leverage design for maximum power
- Plastic-dipped handles (TJ887 has thicker heavy-duty grips)



| Model No. | Mfg. No. | Overall Length" | Price /Each |
|-----------|-----------|-----------------|-------------|
| TJ885 | D213-8NE | 8 11/16 | 63.70 |
| TJ886 | D213-9NE | 9 3/8 | 62.80 |
| TJ887 | HD213-9NE | 9 1/2 | 69.80 |
| TJ888* | D2000-9NE | 9 3/8 | 79.80 |



* Has extra heavy-duty side cutters.

HIGH LEVERAGE CABLE CUTTERS

- Cuts cables with remarkable ease
- Cuts up to: 4/0 aluminum (not ACSR), 2/0 soft copper
- Compact design fits easily in most tool pouches
- Plastic-dipped handles



| Model No. | Mfg. No. | Overall Length" | Price /Each |
|-----------|----------|-----------------|-------------|
| VU139 | 63050 | 9 9/16 | 58.50 |



HIGH LEVERAGE SIDE CUTTERS WITH CRIMPING DIE

- Smooth, streamlined nose with knurled jaws
- High-leverage design for maximum power
- Crimping die at hinge
- Plastic-dipped handles



| Model No. | Mfg. No. | Overall Length" | Price /Each |
|-----------|--------------|-----------------|-------------|
| TJ889 | D213-9NE-CR | 9 3/8 | 82.80 |
| TJ890* | D2000-9NE-CR | 9 3/8 | 97.20 |



* Has extra heavy-duty side cutters.

HIGH LEVERAGE SIDE CUTTERS WITH BOLT HOLDER

- Smooth, streamlined nose with knurled jaws
- High-leverage design for maximum power
- Designed to hold 5/8"-11 bolts without damaging them
- Plastic-dipped handles



| Model No. | Mfg. No. | Overall Length" | Price /Each |
|-----------|-------------|-----------------|-------------|
| TJ891 | D213-9NETH | 9 3/8 | 72.70 |
| TJ892* | HD213-9NETH | 9 1/2 | 78.70 |



* Has extra heavy-duty side cutters.

Can't find what you're looking for?

Call us today!

PLIERS

SIDE CUTTERS FOR REBAR WORK

- Specially designed knurled jaws
- Cutter designed to cut rebar tie wire
- Hook bend in one handle for no-slip grip
- Coil spring holds jaws open
- Plastic-dipped handles



| Model No. | Mfg. No. | Overall Length" | Price /Each |
|-----------|------------|-----------------|-------------|
| TJ893 | D201-7CST | 9 1/4 | 77.80 |
| TJ894* | D2000-7CST | 9 1/4 | 96.40 |



* Has extra heavy-duty side cutters.

HIGH LEVERAGE SIDE CUTTERS FOR REBAR WORK

- High-leverage design for maximum power
- Cutter designed to cut rebar tie wire
- Hook bend in one handle for no-slip grip
- Coil spring holds jaws open
- Plastic-dipped handles



| Model No. | Mfg. No. | Overall Length" | Price /Each |
|-----------|-----------|-----------------|-------------|
| TJ895 | D213-9ST | 9 3/8 | 77.80 |
| TJ896* | D2000-9ST | 9 3/8 | 99.90 |



* Has extra heavy-duty side cutters.

HIGH-LEVERAGE DIAGONAL CUTTERS

- High-leverage design for maximum power
- Standard bevel cut design
- Plastic-dipped, hand-form style handles



| Model No. | Mfg. No. | Overall Length" | Price /Each |
|-----------|----------|-----------------|-------------|
| TJ897 | D228-8 | 8 1/16 | 48.90 |
| TJ898* | D2000-28 | 8 1/16 | 59.90 |



* Has extra heavy-duty cutters.

ANGLED HEAD DIAGONAL CUTTERS

- High-leverage design for maximum power
- Standard bevel cut design
- Angled head for easier work in confined areas
- Plastic-dipped, hand-form style handles



| Model No. | Mfg. No. | Overall Length" | Price /Each |
|-----------|----------|-----------------|-------------|
| TJ899 | D248-8 | 8 1/16 | 49.90 |
| TJ900* | D2000-48 | 8 1/16 | 63.60 |



* Has extra heavy-duty cutters.

TAPERED NOSE DIAGONAL CUTTERS

- Tapered nose for working in confined areas
- Standard bevel cut design
- Plastic-dipped, hand-form style handles



| Model No. | Mfg. No. | Overall Length" | Price /Each |
|-----------|----------|-----------------|-------------|
| TJ903 | D202-6 | 6 1/8 | 49.90 |
| TJ904* | D202-6C | 6 1/8 | 53.40 |



* Has coil spring to hold jaws open.

MIDGET TAPERED NOSE DIAGONAL CUTTERS

- Sharp nose for reaching into confined areas
- Semi-flush cut design
- Plastic-dipped handles

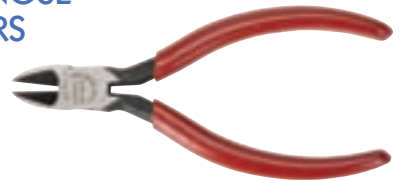

| Model No. | Mfg. No. | Overall Length" | Price /Each |
|-----------|----------|-----------------|-------------|
| TJ905 | D245-5 | 5 1/16 | 49.90 |



MIDGET POINTED NOSE DIAGONAL CUTTERS

- Sharp nose for reaching into confined areas
- Semi-flush cut design
- Coil spring holds jaws open
- Plastic-dipped handles



| Model No. | Mfg. No. | Overall Length" | Price /Each |
|-----------|----------|-----------------|-------------|
| TJ907 | D209-4C | 4 1/4 | 55.30 |
| TJ908 | D209-5C | 5 1/16 | 54.80 |



MIDGET STANDARD NOSE DIAGONAL CUTTERS

- General purpose cutter
- Semi-flush cut design
- Plastic-dipped handles



| Model No. | Mfg. No. | Overall Length" | Price /Each |
|-----------|----------|-----------------|-------------|
| TJ909 | D257-4 | 4 1/4 | 52.20 |
| TJ910* | D257-4C | 4 1/4 | 54.80 |

* Has coil spring to hold jaws open.

MIDGET TAPERED NOSE DIAGONAL CUTTERS

- Small head for precise cuts in hard-to-reach areas
- Flush cut design for a squared off finish
- Has coil spring to hold jaw open
- Plastic-dipped handles



| Model No. | Mfg. No. | Overall Length" | Price /Each |
|-----------|----------|-----------------|-------------|
| TJ911 | D295-4C | 4 1/4 | 63.70 |

STANDARD LONG NOSE PLIERS

- Knurled jaws for solid grip
- Durable design for long life
- Plastic-dipped handles



| Model No. | Mfg. No. | Overall Length" | Price /Each |
|-----------|----------|-----------------|-------------|
| TJ925 | D301-6 | 6 5/8 | 38.20 |
| TJ928* | D301-6C | 6 5/8 | 41.90 |

* Has coil spring to hold jaws open.



LONG NOSE WITH SIDE CUTTER

- Knurled jaws for solid grip
- Side cutter
- Plastic-dipped handles



| Model No. | Mfg. No. | Overall Length" | Price /Each |
|-----------|----------|-----------------|-------------|
| TJ931 | D203-6 | 6 5/8 | 43.30 |
| TJ932 | D203-7 | 7 3/16 | 44.90 |
| TJ933 | D203-8 | 8 7/16 | 56.10 |
| TJ935* | D203-6C | 6 5/8 | 46.90 |
| TJ936* | D203-7C | 7 3/16 | 49.80 |

* Has coil spring to hold jaws open.



LONG NEEDLE NOSE PLIERS

- Knurled jaws for solid grip
- Ideal for assembly work in tight areas
- Coil spring to hold jaws open
- Plastic-dipped handles



| Model No. | Mfg. No. | Overall Length" | Price /Each |
|-----------|------------|-----------------|-------------|
| TJ938 | D318-51/2C | 5 5/8 | 45.80 |

SLIM LONG NOSE PLIERS

- Knurled jaws for solid grip
- Needle tip only 1/32" for precise work
- Coil spring to hold jaws open
- Plastic-dipped handles



| Model No. | Mfg. No. | Overall Length" | Price /Each |
|-----------|------------|-----------------|-------------|
| TBT712 | D307-51/2C | 5 5/8 | 42.90 |

MIDGET SLIM NOSE PLIERS

- Knurled jaws for solid grip
- Designed for extremely precise work
- Coil spring to hold jaws open
- Plastic-dipped handles



| Model No. | Mfg. No. | Overall Length" | Price /Each |
|-----------|------------|-----------------|-------------|
| TJ940 | D321-41/2C | 4 3/16 | 39.90 |

MIDGET CURVED NEEDLE NOSE PLIERS

- Polished jaws to prevent wire nicking
- Angled tip for intricate work
- Coil spring to hold jaws open
- Plastic-dipped handles



| Model No. | Mfg. No. | Overall Length" | Price /Each |
|-----------|------------|-----------------|-------------|
| TJ941 | D320-41/2C | 4 3/4 | 49.90 |

WIRE STRIPPERS/CUTTERS

- Hardened steel construction for long life
- Narrow nose design fits into hard to reach areas
- Black oxide finish
- Plastic-dipped handle



| Model No. | Mfg. No. | Strips AWG Gauges | Overall Length" | Price /Each |
|-----------|----------|---------------------------------|-----------------|-------------|
| TJ946 | 11045 | 10, 12, 14, 16, 18 solid wire | 6 1/4 | 26.10 |
| TJ947 | 11046 | 16, 18, 20, 22, 24, 26 stranded | 6 1/4 | 27.50 |
| TJ948 | 11047 | 22, 24, 26, 28 30 solid wire | 6 1/4 | 28.90 |



WIRE STRIPPERS/CUTTERS

- Scissor style with 1/2" cutter
- Nose designed to bend, shape or pull wire
- Holes for looping wire ends
- Coil spring to hold jaws open
- Plastic-dipped handles

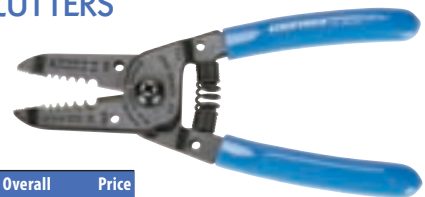

| Model No. | Mfg. No. | Strips AWG Gauges | Overall Length" | Price /Each |
|-----------|----------|------------------------|-----------------|-------------|
| TJ949 | 1011 | 10, 12, 14, 16, 18, 20 | 6 1/8 | 24.90 |



COMPACT WIRE STRIPPERS/CUTTERS

- Lightweight, compact design
- Nut along side locks in required stripping size
- Hole for looping wire ends
- Plastic-dipped handles



| Model No. | Mfg. No. | Strips AWG Gauges | Overall Length" | Price /Each |
|-----------|----------|-------------------|-----------------|-------------|
| TJ950 | 1004 | 12 - 26 | 5 | 16.10 |
| TJ951* | 1003 | 12 - 26 | 5 | 17.80 |

* With spring to hold jaws open.



ALL-PURPOSE LONG NOSE TOOLS

- Cuts bolts and wire, strips and crimps
- Nose designed to bend, shape or pull wire
- Long nose for reaching into tight areas
- Plastic-dipped handles



| Model No. | Mfg. No. | Strips AWG Gauges | Overall Length" | Price /Each |
|-----------|----------|-------------------|-----------------|-------------|
| TJ952 | 1010 | 10 - 22 | 8 1/4 | 41.50 |



PLIERS

LOCKING PLIERS

- Tempered chrome vanadium steel jaws
- Hardened tension bar with toggle mechanism provides secure locking action
- Smooth screw adjustment for easy and rapid setting
- Meets ANSI standards

aurora tools



CURVED JAWS WITH WIRE CUTTER

| Model No. | Grip | Length" | Price/Each |
|-----------|-----------|---------|------------|
| TJZ090 | Steel | 4 | 7.70 |
| TJZ091 | Composite | 5 | 11.00 |
| TJZ092 | Composite | 7 | 12.45 |
| TJZ093 | Composite | 10 | 15.35 |



LONG NOSE WITH WIRE CUTTER

| Model No. | Grip | Length" | Price/Each |
|-----------|-----------|---------|------------|
| TJZ094 | Steel | 4 | 9.15 |
| TJZ095 | Composite | 6 | 10.75 |



C-CLAMPS WITH SWIVEL PADS

| Model No. | Grip | Length" | Price/Each |
|-----------|-------|---------|------------|
| TJZ096 | Steel | 6 | 14.00 |
| TJZ097 | Steel | 11 | 23.10 |



LOCKING WELDING CLAMPS

| Model No. | Grip | Length" | Price/Each |
|-----------|-------|---------|------------|
| TJZ098 | Steel | 9 | 19.75 |



LOCKING SHEET METAL TOOLS

| Model No. | Grip | Length" | Price/Each |
|-----------|-------|---------|------------|
| TJZ099 | Steel | 8 | 16.90 |



AUTOMATIC™ PLIERS & C-CLAMPS

- Heavy-duty steel construction
- Self-adjusts to the work piece
- Pressure screw allows the user to set their own jaw pressure
- Re-engineered release lever gives pinch free controlled release
- Meets or exceeds all ANSI and ASME standards



TLV139



TLV142



| Model No. | Mfg. No. | Description | Price/Each |
|-----------|----------|------------------------------|------------|
| TLV302 | 09300 | 7" Needle Nose | 37.40 |
| TLV140 | 06100 | 6" Curved Jaw | 34.40 |
| TLV139 | 10100 | 10" Curved Jaw | 39.40 |
| TLV304 | 06200 | 7" C-Clamp | 36.90 |
| TLV141 | 06201 | 7" C-Clamp with Swivel Pads | 39.90 |
| TLV305 | 10200 | 11" C-Clamp | 53.60 |
| TLV142 | 10201 | 11" C-Clamp with Swivel Pads | 57.90 |
| TLV306 | 18200 | 19" C-Clamp | 73.80 |
| TLV143 | 18201 | 19" C-Clamp with Swivel Pads | 77.40 |

WISE-GRIP®

IRWIN
WISE-GRIP®

CURVED JAWS WITH WIRE CUTTER

| Model No. | Overall Length" | Price/Each |
|-----------|-----------------|------------|
| TM909 | 4 | 18.20 |
| TM910 | 5 | 20.30 |
| TM917 | 7 | 20.80 |
| TM873 | 10 | 21.10 |



STRAIGHT JAWS

| Model No. | Overall Length" | Price/Each |
|-----------|-----------------|------------|
| TM916 | 7 | 20.80 |
| TM872 | 10 | 21.10 |



LONG NOSE WITH WIRE CUTTER

| Model No. | Overall Length" | Price/Each |
|-----------|-----------------|------------|
| TM908 | 4 | 20.50 |
| TM912 | 6 | 21.80 |
| TM952 | 9 | 26.10 |



LOCKING CHAIN CLAMPS

| Model No. | Overall Length" | Price/Each |
|-----------|-----------------|------------|
| TM985 | 9 | 46.40 |
| TM984* | 18 | 23.40 |



* Extension chain.

C-CLAMPS WITH REGULAR TIPS

| Model No. | Overall Length" | Price/Each |
|-----------|-----------------|------------|
| TM913 | 6 | 19.40 |
| TM971 | 11 | 32.70 |
| TM980 | 18 | 47.90 |
| TM996 | 24 | 59.90 |



C-CLAMPS WITH SWIVEL PADS

| Model No. | Overall Length" | Price/Each |
|-----------|-----------------|------------|
| TN052 | 4 | 19.20 |
| TM914 | 6 | 21.90 |
| TM972 | 11 | 35.30 |
| TM981 | 18 | 49.60 |
| TM997 | 24 | 62.40 |



LOCKING WELDING CLAMPS

| Model No. | Overall Length" | Price/Each |
|-----------|-----------------|------------|
| TN198 | 9 | 36.70 |



LOCKING SHEET METAL TOOLS

| Model No. | Overall Length" | Price/Each |
|-----------|-----------------|------------|
| TN197 | 8 | 30.60 |



LARGE JAW LOCKING PLIERS

| Model No. | Overall Length" | Price/Each |
|-----------|-----------------|------------|
| TM875 | 12 | 32.20 |



LOCKING WRENCHES WITH WIRE CUTTER

| Model No. | Overall Length" | Price/Each |
|-----------|-----------------|------------|
| TD351 | 10 | 28.10 |
| TD352 | 7 | 22.10 |
| TD353 | 4 | 19.20 |



6-PC. INTERNAL/EXTERNAL CONVERTIBLE PLIER SETS

- 3 pliers and 3 replacement tip sets in blow-moulded plastic case
- Approximate weight: 3.48 lbs.

KIT INCLUDES:

Pliers and tips for shaft and bore dia.:
1/8" to 1", 1/4" to 2", 1 1/2" to 4"

Model No. UO284
Mfg. No. 68-079
Price/Each \$176.00



3-PIECE BASIC PLIERS SETS

KIT INCLUDES:

Slip joint, 6" L (TJZ078)
Diagonal cutting, 6" L (TJZ083)
Long nose cut, 6" L (TJZ086)

Note: Black nickel finish on all models
Model No. TLZ795
Price/Each \$26.50



3-PIECE DIAGONAL CUTTING PLIERS

KIT INCLUDES:

5" L (TJZ082)
6" L (TJZ083)
7" L (TJZ084)

Note: Black nickel finish on all models
Model No. TLZ789
Price/Each \$28.80



3-PIECE LONG NOSE CUTTING PLIERS SETS

KIT INCLUDES:

5" L (TJZ085)
6" L (TJZ086)
8" L (TJZ087)

Note: Black nickel finish on all models
Model No. TLZ790
Price/Each \$28.20



12-PC QTR-TURN™ CONVERTIBLE RETAINING RING PLIERS SETS

- For 1/4" to 3 1/2" rings
- Use with either external or internal retaining rings
- For fast and easy conversion, make a 1/4 turn to release halves, then position into alternate slot - another 1/4 turn and it is back together
- Furnished in blow-moulded plastic case

Model No. TLZ109
Mfg No. 68-016
Price/Each \$469.00



SET INCLUDES:

| Model No. | Mfg. No. | Description | Price /Each |
|-----------|----------|---------------------------------------|-------------|
| TLY794 | 68-001 | 0.038" Tip, 1/4 Convertible, Straight | 32.20 |
| TLY795 | 68-002 | 0.038" Tip, 1/4 Convertible, 45° | 33.90 |
| TLY796 | 68-003 | 0.038" Tip, 1/4 Convertible, 90° | 32.80 |
| TLY797 | 68-004 | 0.047" Tip, 1/4 Convertible, Straight | 33.20 |
| TLY798 | 68-005 | 0.047" Tip, 1/4 Convertible, 45° | 34.90 |
| TLY799 | 68-006 | 0.047" Tip, 1/4 Convertible, 90° | 35.80 |
| TLY800 | 68-007 | 0.070" Tip, 1/4 Convertible, Straight | 37.30 |
| TLY801 | 68-008 | 0.070" Tip, 1/4 Convertible, 45° | 37.90 |
| TLY802 | 68-009 | 0.070" Tip, 1/4 Convertible, 90° | 38.60 |
| TLY803 | 68-010 | 0.090" Tip, 1/4 Convertible, Straight | 47.40 |
| TLY804 | 68-011 | 0.090" Tip, 1/4 Convertible, 45° | 53.80 |
| TLY805 | 68-012 | 0.090" Tip, 1/4 Convertible, 90° | 54.80 |

11-PIECE ALL-PURPOSE PLIERS SETS

KIT INCLUDES:

Slip joint, 6" L (TJZ078)
Groove joint, 8" L (TJZ079)
Groove joint, 10" L (TJZ080)
Diagonal cutting, 5" L (TJZ082)
Diagonal cutting, 6" L (TJZ083)
Diagonal cutting, 7" L (TJZ084)
Long nose cut, 5" L (TJZ085)
Long nose cut, 6" L (TJZ086)
Long nose cut, 8" L (TJZ087)
Linesman cutting, 7" L (TJZ088)
Linesman cutting, 8" L (TJZ089)

Note: Black nickel finish on all models
Model No. TLZ793
Price/Each \$115.00



PLIERS

4-PIECE CURVED JAW LOCKING PLIERS W/WIRE CUTTER SETS

KIT INCLUDES:

4" L (TJZ090), 5" L (TJZ091), 7" L (TJZ092), 10" L (TJZ093)

Model No. TLZ791

Price/Each \$42.55



aurora tools

WELDER CLAMP SET

KIT INCLUDES:

6" C-Clamp with swivel pad (TJZ096)

11" C-Clamp with swivel pad (TJZ097)

9" Locking welding clamp (TJZ098)

8" Locking sheet metal clamp (TJZ099)

• Type: 2 C-clamps, 2 locking clamps

• Grip: Steel

• No. of clamps: 4

Model No. TLV133

Price/Each \$71.55



aurora tools

8-PIECE LOCKING PLIERS SETS

KIT INCLUDES:

Curved jaw w/wire cutter, 4" L (TJZ090)

Curved jaw w/wire cutter, 5" L (TJZ091)

Curved jaw w/wire cutter, 7" L (TJZ092)

Curved jaw w/wire cutter, 10" L (TJZ093)

Long nose w/wire cutter, 4" L (TJZ094)

Long nose w/wire cutter, 6" L (TJZ095)

C-clamps w/swivel pads, 6" L (TJZ096)

C-clamps w/swivel pads, 11" L (TJZ097)

Model No. TLZ792

Price/Each \$95.85

aurora tools

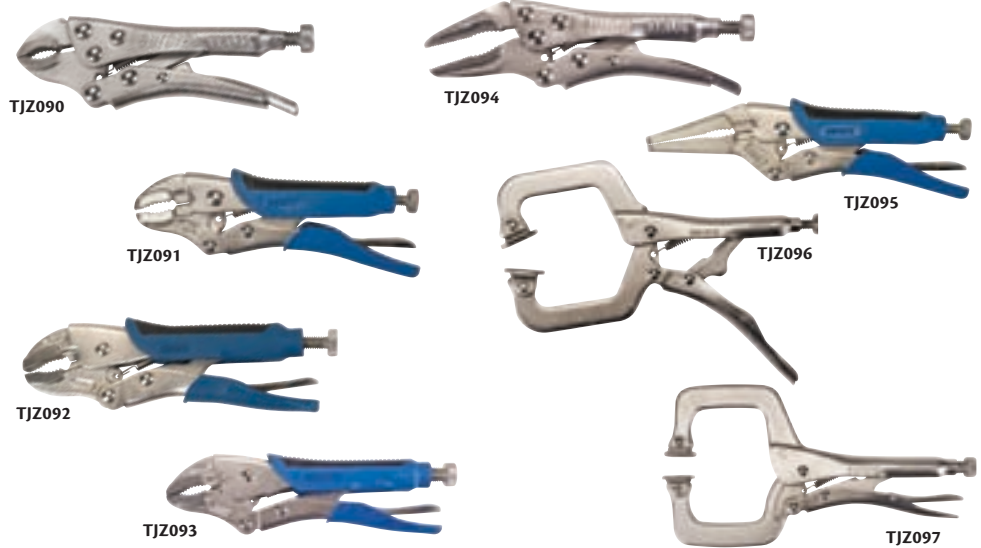

19-PIECE ALL-PURPOSE PLIERS SETS

KIT INCLUDES:

Pliers, black nickel finish:

Slip joint, 6" L (TJZ078)

Groove joint, 8" L (TJZ079)

Groove joint, 10" L (TJZ080)

Diagonal cutting, 5" L (TJZ082)

Diagonal cutting, 6" L (TJZ083)

Diagonal cutting, 7" L (TJZ084)

Long nose cut, 5" L (TJZ085)

Long nose cut, 6" L (TJZ086)

Long nose cut, 8" L (TJZ087)

Linesman cutting, 7" L (TJZ088)

Linesman cutting, 8" L (TJZ089)

Locking pliers:

Curved jaw w/wire cutter, 4" L (TJZ090)

Curved jaw w/wire cutter, 5" L (TJZ091)

Curved jaw w/wire cutter, 7" L (TJZ092)

Curved jaw w/wire cutter, 10" L (TJZ093)

Long nose w/wire cutter, 4" L (TJZ094)

Long nose w/wire cutter, 6" L (TJZ095)

C-clamps w/swivel pads, 6" L (TJZ096)

C-clamps w/swivel pads, 11" L (TJZ097)

Model No. TLZ794

Price/Each \$210.00

aurora tools

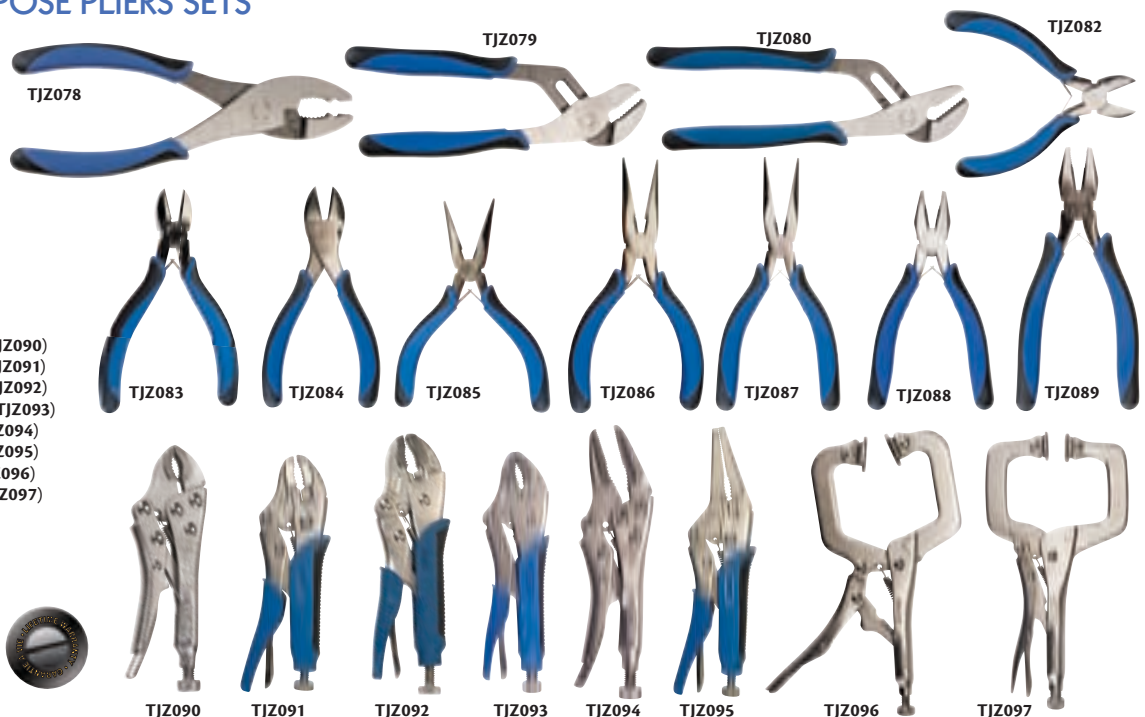

KNIVES, SCISSORS & BOLT CUTTERS

POWERFRAME FOLDING KNIVES

- Powerframe is a one-hand operated folding knife
- Strong stainless steel handle is cut out to save weight
- Titanium-coated blade and handles make it more corrosion resistant

Specifications:
Overall Length: 7"
Length Closed: 4"
Width: 0.55"
Weight: 3.20 oz.



| Model No. | Mfg. No. | Description | Blade Length" | Price/Each |
|-----------|----------|---------------|---------------|------------|
| TLZ904 | 22-01965 | Fine Edge | 3.00 | 44.40 |
| TLZ905 | 22-01964 | Serrated Edge | 3.00 | 45.00 |

REMIX FOLDING KNIVES

- Remix is a one-hand operated folding knife
- 440A stainless steel blade
- Titanium nitride coated aluminum handles add support and corrosion resistance
- Features a large finger hole for extra stability and grip

Specifications:
Overall length: 7.35"
Closed length: 4.45"
Width closed: 0.55"
Weight: 4.20 oz.



| Model No. | Mfg. No. | Description | Blade Length" | Price/Each |
|-----------|----------|---------------|---------------|------------|
| TLZ906 | 22-41968 | Fine Edge | 2.90 | 51.20 |
| TLZ907 | 22-41969 | Serrated Edge | 2.90 | 50.90 |

MOMENT POCKET FOLDING KNIVES

- Dual thumb studs allow for 1-handed blade opening
- Stout stainless steel clip keeps it securely accessible on the top of a pocket
- Features: Textured rubber handles, 1-handed opening, glass bead blade finish, frame lock, removable stainless steel pocket clip, Backed by Gerber's lifetime warranty

Specifications:
Overall length: 7.38"
Closed length: 4.38"
Weight: 2.5 oz.
Handle material: Steel with rubber overmold



| Model No. | Mfg. No. | Description | Blade Length" | Price/Each |
|-----------|-----------|-------------|---------------|------------|
| TLV725 | 31-002216 | Fine Edge | 3.00 | 38.50 |

OBSIDIAN FOLDING KNIVES

- Dual thumb studs for 1-handed opening
- Safety-style lock that ensures the blade stays open or closed
- Includes: Cross point and flat head drivers, file and bottle opener
- Features: Safety lock, 440 stainless blade and glass-filled nylon handle

Specifications:
Overall length: 7.1"
Closed length: 4.1"
Weight: 4.6 oz.



| Model No. | Mfg. No. | Description | Blade Length" | Price/Each |
|-----------|----------|-------------|---------------|------------|
| TNB016 | 22-41021 | Fine Edge | 3.00 | 68.90 |

HINDERER RESCUE™ FOLDING KNIVES

- Design was conceived by a fire fighter, integrating some important features a fire fighter will need
- Even while wearing turn-out gloves, using this knife will not be an issue
- The knife has larger features and mechanisms built-in
- Includes a 9-pc. screwdriver bit set and a ballistic nylon sheath
- Features: Hook cutter, safely slices seatbelts, window punch, oxygen tank wrench

Specifications:
Overall length: 8.5"
Closed length: 5.1"
Weight: 5.6 oz.

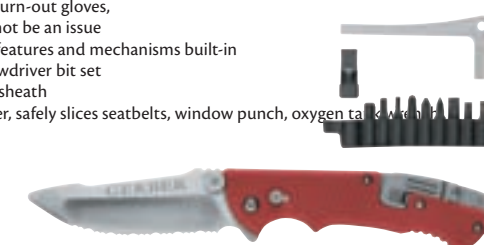

| Model No. | Mfg. No. | Description | Blade Length" | Price/Each |
|-----------|----------|---------------|---------------|------------|
| TLV724 | 22-01534 | Serrated Edge | 3.50 | 181.00 |



aurora tools

INDUSTRIAL MULTI-TOOLS

- Stainless steel components
- Anodized aluminum body with ABS inlays provides premium comfort
- Heavy duty nylon pouch
- Self locking components for safe use
- Gun metal finish

Components: Flat-nose pliers, wire cutter, fine edge knife, Phillips screwdriver, bottle opener, small and medium flat screwdriver, metal/wood file, double tooth saw, serrated knife, can opener

Specifications:
Overall length: 6.25"
Closed length: 4"
Weight: 9.3 oz.

Model No. TLZ463
Price/Each \$20.95



MULTI-PLIER® 600

- Stainless steel handle
- One-handed opening tool
- Patented Saf.T.Plus™ locking system assures tool components stay in place while in use

Components: Needlenose pliers, wire cutter, wire crimper, fine edge knife, serrated knife, cross point screwdriver, small, medium and large flat blade screwdrivers, lanyard ring, can opener, bottle opener, file, ruler and nylon sheath

Specifications:
Overall Length: 6.61"
Closed Length: 5.04"
Weight: 9 oz.

Model No. TE179 Stainless finish
Price/Each \$111.00

Model No. TLV727 Black finish
Price/Each \$119.00



COMPACT SPORT™ MULTI-PLIER® 400

- Smaller version of our Multi-Plier® 600 series
- Stainless steel handle
- One-handed opening tool
- Patented Saf.T.Plus™ locking system assures tool components stay in place while in use

Components: Needlenose pliers, wire cutter, wire crimper, serrated knife blade, scissors, cross point screwdriver, small, medium and large flat blade screwdrivers, can opener, bottle opener and nylon sheath

Specifications:
Overall length: 5.63"
Closed length: 4.37"
Weight: 6.8 oz.

Model No. UG697
Price/Each \$86.60



DIESEL™ MULTI-PLIER®

- Big, industrial-strength multi-tool featuring the ease and convenience of wrist-flick deployment
- Bigger than average individual stainless steel tools and more rugged than normal
- Patented Saf.T.Plus™ locking system assures tool components stay in place while in use

Components: Needlenose pliers, wire cutter, partially serrated knife blade, cross point screwdriver, small, medium and large flat blade screwdrivers, can opener, bottle opener, file, saw and scissors, ballistic nylon sheath

Specifications:
Overall Length: 6.61"
Closed Length: 4.92"
Weight: 9.0 oz.

Model No. TLZ909
Price/Each \$144.00



OFFICE PRODUCTS

INSTRUMENTS, SCALES & ELECTRICAL

SHIPPING & PACKAGING

TOOLS & EQUIPMENT

WELDING & METALWORKING

SAFETY EQUIPMENT & SUPPLIES

JANITORIAL & MAINTENANCE

MATERIAL HANDLING & STORAGE

KNIVES, SCISSORS & BOLT CUTTERS

INDUSTRIAL

HEAVY-DUTY INDUSTRIAL SHEARS

- Finest quality cutlery steel
- Black handle standard, cushion grip on some
- Hot drop-forged polished blades
- Patented Set-Easy® pivot



Wiss®

| Model No. | Mfg. No. | Description | Overall Length" | Cut Length" | Wt. lbs. | Price /Each |
|-----------|----------|------------------|-----------------|-------------|----------|-------------|
| UG758 | W22N | Black handle | 12 1/4 | 6 1/8 | 1.13 | 58.20 |
| UG759 | W20P | Red cushion grip | 10 1/4 | 4 3/4 | 0.76 | 54.70 |
| UG760 | W22P | Red cushion grip | 12 1/4 | 6 1/8 | 1.17 | 57.60 |
| UG761 | W20SP | Black Handle* | 10 1/4 | 4 3/4 | 0.76 | 55.80 |

* Safety point blades

INDUSTRIAL SHEARS

- Often used in the poultry industry
- Made from high quality carbon steel
- Comfortable handle with enlarged lower ring
- Hot drop-forged nickel-plated blades
- Patented Set-Easy® pivot



Wiss®

| Model No. | Mfg. No. | Description | Overall Length" | Cut Length" | Wt. lbs. | Price /Each |
|-----------|----------|----------------------|-----------------|-------------|----------|-------------|
| UG766 | 1DSN | Nickel-plated handle | 8 1/2 | 3 | 0.42 | 37.20 |

INDUSTRIAL SHEARS

- Professional dressmaker and industrial use
- Finest quality cutlery steel
- Comfortable, shaped handle
- Hot drop-forged nickel-plated blades
- Patented Set-Easy® pivot



Wiss®

| Model No. | Mfg. No. | Description | Overall Length" | Cut Length" | Wt. lbs. | Price /Each |
|-----------|----------|--------------|-----------------|-------------|----------|-------------|
| WJ189 | 426N | Black handle | 6 1/4 | 2 5/8 | 0.21 | 34.70 |
| UG763 | 27N | Black handle | 7 1/2 | 3 1/8 | 0.19 | 38.30 |
| UG764 | 28N | Black handle | 8 1/8 | 3 3/4 | 0.36 | 39.50 |
| UG765 | 29N | Black handle | 9 1/4 | 4 | 0.48 | 43.90 |

8" TAKE APART UTILITY SCISSORS

- Blades come apart for easy cleaning and sharpening
- Serrated blade
- Semi-circular notch on lower blade, keeps circular items in place when cutting
- Corrosion resistant stainless blades, polypropylene ergonomic grips

Model No. TKZ887
Mfg. No. W8TA
Price/Each \$19.30

Wiss®



10" SHOP SHEARS

- High leverage grip
- 420 stainless blades
- Serrated lower blade
- Heavy-duty blades cut cardboard, heavy fabric, rope, rubber, screen and more

Model No. TKZ886
Mfg. No. W912
Price/Each \$19.20

Wiss®



9" EASY SNIP UTILITY SHEARS

- Spring loaded blades, reduce fatigue
- Soft grip handles
- 420 stainless blade
- Wire cutting notch, for light gauge wire
- Safety latch to keep closed when not in use

Model No. TKZ888
Mfg. No. WEZSNIP
Price/Each \$15.30

Wiss®



INDUSTRIAL STRAIGHT TRIMMERS

- Designed for industrial use
- Finest quality cutlery steel
- Hot drop-forged nickel-plated blades
- Patented Set-Easy® pivot



Wiss®

| Model No. | Mfg. No. | Description | Overall Length" | Cut Length" | Wt. lbs. | Price /Each |
|-----------|----------|--------------|-----------------|-------------|----------|-------------|
| UG774 | 37N | Black handle | 7 1/8 | 3 1/8 | 0.25 | 35.70 |
| UG775 | 38N | Black handle | 8 1/8 | 3 3/4 | 0.36 | 39.40 |
| UG777 | W30 | Black handle | 10 1/4 | 4 7/8 | 0.75 | 62.60 |

HIGH-LEVERAGE INDUSTRIAL SHEARS

- Finest quality cutlery steel
- One blade ground to knife-edge for faster, cleaner, easier cutting of tough synthetic fibers
- Red cushion grip handles provide maximum leverage
- Hot drop-forged polished blades, safely-rounded for extra protection



Wiss®

| Model No. | Mfg. No. | Description | Overall Length" | Cut Length" | Wt. lbs. | Price /Each |
|-----------|------------|--------------------|-----------------|-------------|----------|-------------|
| WJ178 | W1225HLSPN | Red cushion handle | 10 1/4 | 4 3/4 | 0.7 | 55.20 |

GENERAL PURPOSE

SOLID-STEEL STRAIGHT TRIMMERS

- High quality nickel plated blades
- Made of high quality carbon steel
- High quality construction for long life



Wiss®

| Model No. | Mfg. No. | Description | Overall Length" | Cut Length" | Wt. lbs. | Price /Each |
|-----------|----------|--------------|-----------------|-------------|----------|-------------|
| UG793 | 438N | Black handle | 8 1/8 | 3 3/4 | 0.40 | 36.30 |

HIGH-LEVERAGE SHEARS

- Designed for heavy duty cutting
- Used extensively by florists for stem and wire cutting
- Hot drop-forged, commercial quality
- Serrated nickel-plated blades for easy cuts



Wiss®

| Model No. | Mfg. No. | Description | Overall Length" | Cut Length" | Wt. lbs. | Price /Each |
|-----------|----------|--------------|-----------------|-------------|----------|-------------|
| UQ067 | 2DAN | Black handle | 8 1/4 | 2 1/4 | 0.56 | 39.90 |

HEAVY-DUTY LEATHER CUTTING SCISSORS

- Finest quality cutlery steel
- Hot drop-forged nickel-plated blades
- One serrated blade, the other is edged
- Patented Set-Easy® pivot



Wiss®

| Model No. | Mfg. No. | Description | Overall Length" | Cut Length" | Wt. lbs. | Price /Each |
|-----------|----------|-------------|-----------------|-------------|----------|-------------|
| UG798 | W8BLTN | Ring handle | 4 1/2 | 2 5/8 | 0.67 | 59.90 |

8 1/2" GENERAL PURPOSE SCISSORS

- Stainless blades
- Adjustable pivot
- Blades can be resharpened
- Comfortable grip, high leverage bottom ring

Model No. TKZ889
Mfg. No. W812
Price/Each \$11.40



Wiss®

KNIVES, SCISSORS & BOLT CUTTERS

TEXTILE & FABRIC

UPHOLSTERY, CARPET & FABRIC SHEARS

- Finest quality cutlery steel
- Hot drop-forged polished blades
- Thicker, heavy duty blades to cut tough material
- Patented Set-Easy® pivot



| Model No. | Mfg. No. | Description | Overall Length" | Cut Length" | Wt. lbs. | Price /Each |
|-----------|----------|--------------|-----------------|-------------|----------|-------------|
| UG799 | W20W | Black handle | 10 1/4 | 4 3/4 | 0.88 | 58.40 |
| UG802 | W22W | Black handle | 12 1/4 | 6 1/8 | 1.29 | 66.90 |

POCKET SCISSORS

- Hot drop-forged solid steel
- Flat pattern blades with blunt points
- Scissors are fully nickel plated



| Model No. | Mfg. No. | Description | Overall Length" | Cut Length" | Wt. lbs. | Price /Each |
|-----------|----------|-------------|-----------------|-------------|----------|-------------|
| UG796 | 166 | Ring handle | 6 1/4 | 3 3/4 | 0.21 | 24.90 |

INDUSTRIAL THREAD NIPPERS

- Ice tempered, stainless steel blades
- Blades are micro-honed for smooth precise cutting
- 50% lighter than forged clippers
- Easy to re-sharpen



| Model No. | Mfg. No. | Description | Overall Length" | Cut Length" | Wt. lbs. | Price /Each |
|-----------|----------|--------------|-----------------|-------------|----------|-------------|
| UG813 | TC1 | Sharp points | 4 3/4 | 1 1/8 | 0.21 | 19.50 |

DUCKBILL COMBINATION PATTERN SNIPS

- Cuts moderately tight curves left or right in light stock as well as straight
- Popular with home craftsman and professionals
- Blades of finest quality steel, hot drop-forged for sharp edge and long life
- Rust resistant blades
- Cushion handle for comfort and better grip



| Model No. | Mfg. No. | Length" | Cut Length" | Recommended max. capacity low carbon cold rolled steel | Price /Each |
|-----------|----------|---------|-------------|--|-------------|
| VQ291 | V10N | 10 1/4 | 2 1/4 | 23-gauge | 28.50 |
| VQ292 | V19N | 13 | 3 | 21-gauge | 38.30 |

WISS® SCISSORS - TITANIUM COATED 10"

- The Wiss® 2 Ring Full Metal Body Scissor features full length steel blades that extend through the scissor handle for maximum strength
- Its heavy duty blades have a titanium coating that is 3 times harder than steel for extra durability and a longer life
- This heavy duty scissor is a perfect shop shear where lighter weight scissor just won't make the cut
- Adjustable pivot allows fine-tuning to most comfortable setting
- Cuts paper, cardboard, heavy fabric, rope, rubber, leather, plastics, and more
- Point style: Sharp
- Handle: Cushion



| Model No. | Mfg. No. | Overall Length" | Cut Length" | Price /Each |
|-----------|----------|-----------------|-------------|-------------|
| TY0559 | W10TM | 10 | 5 | 26.10 |

SPECIALTY

ELECTRICIAN'S SCISSORS

- Scraper and file on back edge of blade
- Full nickel plate for corrosion resistance
- Used for wire splicing, stripping and cutting



| Model No. | Mfg. No. | Description | Overall Length" | Cut Length" | Wt. lbs. | Price /Each |
|-----------|----------|-------------|-----------------|-------------|----------|-------------|
| UG815 | 175E | Ring handle | 5 1/4 | 1 7/8 | 0.17 | 19.90 |

ELECTRONICS & FILAMENT SCISSORS

- Hot drop-forged solid steel
- Coil spring opens blades after each cut
- Straight, precise cutting jaws
- High quality polished blades



| Model No. | Mfg. No. | Description | Overall Length" | Cut Length" | Wt. lbs. | Price /Each |
|-----------|----------|--------------|-----------------|-------------|----------|-------------|
| UG819 | 605N | Black handle | 5 | 3/4 | 0.21 | 29.80 |

LIGHT METAL-CUTTING SNIPS

- Used in electronic and appliance light metal cutting
- Straight, precise cutting jaws
- High quality polished blades



| Model No. | Mfg. No. | Description | Overall Length" | Cut Length" | Wt. lbs. | Price /Each |
|-----------|----------|--------------|-----------------|-------------|----------|-------------|
| UG820 | J7SN | Black handle | 7 | 1 1/4 | 0.33 | 29.20 |

INDUSTRIAL TRIMMING, GRAPE & ORCHID SNIPS

- Hot drop-forged solid steel
- Coil spring opens blades after each cut
- High quality polished blades with adjustment nut
- Closing latch holds jaws shut when not in use



| Model No. | Mfg. No. | Description | Overall Length" | Cut Length" | Wt. lbs. | Price /Each |
|-----------|----------|--------------|-----------------|-------------|----------|-------------|
| UG821 | C4ASN | Black handle | 8 | 2 1/4 | 0.36 | 37.60 |

WISS® UTILITY SCISSORS - TITANIUM COATED 7"

- The Wiss® No-Ring Scissor is a great utility shear for the home, garden, or workshop
- It features spring loaded blades for reduced hand fatigue on repeated cuts
- The wider heavy duty blades have a titanium coating that is 3 times harder than steel for long life and durability
- Precision ground blades for smooth cutting
- Point Style: Sharp
- Handle: Cushion



| Model No. | Mfg. No. | Overall Length" | Cut Length" | Price /Each |
|-----------|----------|-----------------|-------------|-------------|
| TY0561 | W7T | 9-3/4 | 3 | 24.90 |

KNIVES, SCISSORS & BOLT CUTTERS

METALMASTER® COMPOUND SNIPS

- **VQ280** Cuts left from tight curves to straight
- **VQ281** Cuts right from tight curves to straight
- **VQ282** Cuts straight, left or right in light stock
- Non-slip serrated jaws



| Model No. | Mfg. No. | Grip Colour | Length" | Cut Length" | Recommended Max. Capacity Low Carbon Cold Rolled Steel | Price /Each |
|-----------|----------|-------------|---------|-------------|--|-------------|
| VQ280 | M1R | Red | 9 3/4 | 1 3/8 | 18-gauge steel | 26.40 |
| VQ281 | M2R | Green | 9 3/4 | 1 3/8 | 18-gauge steel | 26.40 |
| VQ282 | M3R | Yellow | 9 3/4 | 1 1/2 | 18-gauge steel | 26.40 |

METALMASTER® SPECIAL SERIES SNIPS

- **TBH824** cuts left
- **TBH825** cuts right
- Specially hardened to cut exotic metals
- Non-slip serrated jaw
- Spring-action for fast, effortless feed
- Non-slip, textured grips and safety latch for superior control

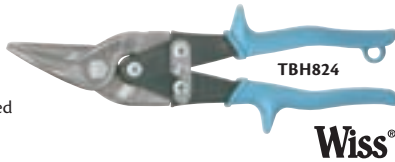

| Model No. | Mfg. No. | Grip Colour | Length" | Cut Length" | Recommended Max. Capacity Low Carbon Cold Rolled Steel | Price /Each |
|-----------|----------|-------------|---------|-------------|--|-------------|
| TBH824 | M1RS1 | Blue | 9 3/4 | 1 3/8 | 18-gauge stainless steel | 42.90 |
| TBH825 | M2RS1 | Blue | 9 3/4 | 1 3/8 | 18-gauge stainless steel | 42.90 |

METALMASTER® COMPOUND ACTION OFFSET VERTICAL SNIPS

- Vertical offset blades keep hands clear of material
- Ideal for increased reach in overhead projects or ground-level cutting
- Cuts low carbon cold rolled steel and other heavy gauge materials
- Non-slip serrated jaw blades help grip material to minimize slip
- Spring-action for fast, effortless feed
- High tensile alloy steel handles and comfort grips for secure control
- Safety latch aids in tool storage and secures tool when not in use
- Red grips (**TLZ902**), cut to the left
- Green grips (**TLZ903**), cut to the right



| Model No. | Mfg. No. | Description | Price /Each |
|-----------|----------|---|-------------|
| TLZ902 | M8R | Offset Vertical Snips cuts to the left | 41.20 |
| TLZ903 | M9R | Offset Vertical Snips cuts to the right | 39.90 |

WISS® MULTIMASTER® COMPOUND ACTION OFFSET SNIPS

- Combines long cut of tinner snips with the strength of compound action
- Compound action design increases force for greater improved performance
- Longer blade length reduces cutting frequency for faster work
- Cuts up to 20 gauge low carbon cold rolled steel, aluminum and plastic
- Features non-slip, serrated jaws to help hold material during cutting
- Handle latch to keep blades closed during storage or when not in use
- Soft textured grips for comfort and safety when handling
- Handle: Cushion



| Model No. | Mfg. No. | Overall Length" | Cut Length" | Price /Each |
|-----------|----------|-----------------|-------------|-------------|
| TTB274 | M400 | 9-3/4 | 3 | 39.10 |

METALMASTER® OFFSET SNIPS

- **VQ283** cuts left and straight
- **VQ284** cuts right and straight
- Offset blades keep hands clear of metal
- Non-slip serrated jaw
- Spring-action for fast, effortless feed



| Model No. | Mfg. No. | Grip Colour | Length" | Cut Length" | Recommended Max. Capacity Low Carbon Cold Rolled Steel | Price /Each |
|-----------|----------|-------------|---------|-------------|--|-------------|
| VQ283 | M6R | Red | 9 1/4 | 1 1/4 | 18-gauge steel | 31.10 |
| VQ284 | M7R | Green | 9 1/4 | 1 1/4 | 18-gauge steel | 31.10 |

METALMASTER® BULLDOG SNIPS

- For notching or trimming extra heavy stock
- Non-slip, serrated
- Spring-action for fast, effortless feed



| Model No. | Mfg. No. | Grip Colour | Length" | Cut Length" | Recommended Max. Capacity Low Carbon Cold Rolled Steel | Price /Each |
|-----------|----------|-------------|---------|-------------|--|-------------|
| TBH827 | M5R | Red | 9 1/4 | 7/8 | 16-gauge steel | 32.70 |

METAL-WIZZ® SNIPS

- Cuts curves, straight or any combination
- Metal-Wizz® snips designed for home craftsman
- Used for cutting screening, hardware cloth, synthetic shingles, tile gutters, downspouts, and carpeting
- Non-slip serrated jaw
- Spring-action for fast, effortless feed



| Model No. | Mfg. No. | Length" | Cut Length" | Recommended Max. Capacity Low Carbon Cold Rolled Steel | Price /Each |
|-----------|----------|---------|-------------|--|-------------|
| TBH828 | MPC3 | 9 | 1 3/8 | 20-gauge steel | 21.50 |

COMPACT AVIATION SNIPS

- All the power of a full size aviation snip, but is 25% smaller
- Extremely compact cutting head allows for great maneuverability, cutting the narrowest radii
- Designed for long continuous, straight and curved cuts, sliding the surface being cut beneath your fingers and reducing the chance of injury
- Practical locking mechanism allows one-handed open and close operation, and limits the maximum opening of the snip
- Compound leverage considerably reduces effort required, improving productivity while reducing hand fatigue
- Ergonomic handles keep hand from slipping



| Model No. | Mfg. No. | Length" | Cut Length" | Cutting Capacity (Regular Metal) | Cutting Direction | Price /Each |
|-----------|----------|-----------------------------------|-------------|----------------------------------|-------------------|-------------|
| TLV291 | D15A-BE | 7 3/16 | 13/16 | 18-gauge | Right | 20.70 |
| TLV292 | D15AL-BE | 7 3/16 | 13/16 | 18-gauge | Left | 20.70 |
| TLV293 | D155-BE | 7 3/16 | 13/16 | 18-gauge | Straight | 20.50 |
| TLV294 | D15-SET | All three styles in a nylon pouch | | | | 58.40 |

KNIVES, SCISSORS & BOLT CUTTERS

3-BLADE HAND CRIMPERS

- Crimps up to 22- and 24-gauge sheet metal
- Compound action jaw made of finest quality steel for better edges and long life
- Rust resistant blades
- Cushion handle for all-weather comfort
- Matte black finish and red plastisol grip



| Model No. | Mfg. No. | Overall Length" | Throat Depth" | Price/Each |
|-----------|----------|-----------------|---------------|------------|
| TBH818 | WC3S | 9 1/4 | 1 1/4 | 34.20 |

5-BLADE HAND CRIMPERS

- Joins sheet metal pipes of same size that are corrugated, round or square
- Compound action jaw made of finest quality steel for better edges and long life
- Rust resistant blades
- Cushion handle for all-weather comfort
- Matte black finish and red plastisol grip



| Model No. | Mfg. No. | Overall Length" | Throat Depth" | Price/Each |
|-----------|----------|-----------------|---------------|------------|
| VQ293 | WC5S | 9 1/4 | 1 1/4 | 32.80 |

MULTIMASTER® SNIPS

- Combines the long cut of tinners snips with the strength of compound action
- Compound action multiplies the force of the hand by five times
- Cuts up to 20-gauge steel



| Model No. | Mfg. No. | Cut Length" | Recommended Max. Capacity Low Carbon Cold Rolled Steel | Price /Each |
|-----------|----------|-------------|--|-------------|
| QF327 | M300 | 10 1/2 | 20-gauge steel | 26.40 |

INDUSTRIAL USE STRAIGHT PATTERN

- Used for straight cuts and wide curves (on light gauge stock)
- Blades individually hand edged for maximum cutting efficiency
- Flat face guides tool along straight line
- Rust resistant blades
- Cushion handle for comfort and better grip



| Model No. | Mfg. No. | Cut Length" | Recommended Max. Capacity Low Carbon Cold Rolled Steel | Price /Each |
|-----------|----------|-------------|--|-------------|
| TBH849 | W7N | 14 1/2 | 18-gauge | 82.20 |

WISS® ALUMINUM HANDLE SNIPS

- Strong and durable lightweight aluminum construction
- Sleek head design allows material to easily flow over snip while cutting
- Handle rings designed for added comfort and greater cutting leverage
- Slim nose, ideal for making cuts in tight places and reaching tight corners
- Easy and quick blade replacement
- Handle: Plain



| Model No. | Mfg. No. | Overall Length" | Cut Length" | Price /Each |
|-----------|----------|-----------------|-------------|-------------|
| TTB874 | W12L | 12 | 3 | 47.20 |
| TTB877 | W14L | 14 | 3-1/4" | 56.30 |

METALMASTER® PIPE & DUCT SNIPS

- Cuts curves, straight or any combination
- Cuts any shape ducts, seams, sheet metal stock, vinyl tiles and plastic laminates
- Non-slip serrated jaw
- Patented ball-bearing jaw action automatically adjusts blade clearance for squarer, cleaner cuts
- Spring-action for fast, effortless feed



| Model No. | Mfg. No. | Cut Length" | Recommended Max. Capacity Low Carbon Cold Rolled Steel | Price /Each |
|-----------|----------|-------------|--|-------------|
| TBH826 | M4R | 9 1/4 | 20-gauge steel | 37.70 |

OFFSET HAND SEAMERS

- 1/4" incremental depth marks on jaw
- Compound action jaw for easy metal bending and flattening made of finest quality steel for better edges and long life
- Rust resistant blades
- Cushion handle for all-weather comfort
- Matte black finish and red plastisol grip



| Model No. | Mfg. No. | Overall Length" | Jaw Depth" | Jaw Width" | Price/Each |
|-----------|----------|-----------------|-------------|------------|------------|
| VQ296 | WS4 | 8 3/4 | 1/4 - 1 1/4 | 3 1/4 | 60.50 |

STRAIGHT PATTERN

- Cuts straight and wide curves (when trimming light gauge stock)
- For plumbing, heating, air conditioning and roofing trades, also used as handyman's tool
- Flat face guides tool along straight line
- Blades of finest quality steel, hot drop-forged for sharp edge and long life
- Rust resistant blades
- Cushion handle for comfort and better grip



| Model No. | Mfg. No. | Cut Length" | Recommended Max. Capacity Low Carbon Cold Rolled Steel | Price /Each |
|-----------|----------|-------------|--|-------------|
| VQ285 | A13N | 7 | 23-gauge | 24.20 |
| VQ286 | A12N | 8 1/4 | 23-gauge | 27.50 |
| VQ287 | A11N | 9 3/4 | 23-gauge | 29.90 |
| VQ288 | A10N | 11 | 21-gauge | 35.30 |
| VQ289 | A9N | 12 1/2 | 20-gauge | 35.70 |

WISS® 10-1/2" COMPOUND ACTION ALL-PURPOSE CUTTER

- 3" serrated blades provide longer cut than most tools
- Serrated blades grab, hold and aggressively cut through the material
- Compound action provides up to 5:1 power ratio for easy cutting
- Chrome-plated blades resist rust and corrosion
- Spring loaded for faster opening
- Non-slip textured cushion grips
- Small closed position handle design for smaller hands
- Cuts low carbon cold rolled steel
- Handle: Cushion



| Model No. | Mfg. No. | Overall Length" | Cut Length" | Price /Each |
|-----------|----------|-----------------|-------------|-------------|
| TBH829 | MPX | 10-1/2 | 3" | 33.50 |

KNIVES, SCISSORS & BOLT CUTTERS



BOLT CUTTERS

- Chrome molybdenum steel jaws
- Centre cutting blades
- Adjusting screws allow for easy and perfect alignment of jaws
- Strong tubular handle with slip-proof rubber grips

aurora tools

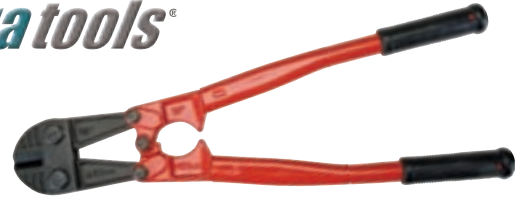

| Model No. | Length" | Max. Jaw Opening" | Price/Each |
|-----------|---------|-------------------|------------|
| TJZ111 | 14 | 1/4 | 28.65 |
| TLV660 | 18 | 5/16 | 39.25 |
| TJZ113 | 24 | 3/8 | 49.55 |
| TLV662 | 36 | 9/16 | 88.70 |

INDUSTRIAL GRADE CENTRE CUT CUTTERS

- General plant maintenance tool
- Drop-forged, precision ground, alloy tool steel jaws with centre-cut blades
- Cuts soft, medium, or hard materials
- Maximum hardness of material to be cut: Brinell 455/Rockwell C48
- Lockplate keeps jaws from loosening
- Toggle joints turn 50 lbs. hand pressure to 4000 lbs. cutting pressure
- Screw-type adjustment realigns edges
- Steel handles with rubber grips

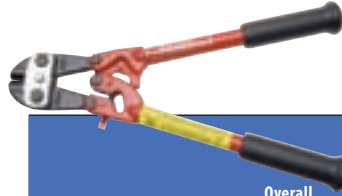

H.K. Porter

| Model No. | Mfg. No. | Wt. lbs. | Overall Length | | Cutting Capacity | | | | Replacement Cutterhead | | | |
|-----------|----------|----------|----------------|------|--|----|--|----|------------------------|-----------|----------|-------------|
| | | | | | Soft and Medium Hard Materials (Up to Brinell 300, Rockwell C31) | | Hard Materials (Up to Brinell 455, Rockwell C48) | | Price /Each | Model No. | Mfg. No. | Price /Each |
| TBG120 | 1490MC | 2.75 | 14 | 356 | 5/16 | 8 | 3/16 | 5 | 147.00 | TBG109 | 1413C | 109.00 |
| YC552 | 0090MC | 3.5 | 18 | 457 | 3/8 | 10 | 1/4 | 6 | 156.00 | TBF924 | 0013C | 108.00 |
| YC554 | 0190MC | 5.25 | 24 | 610 | 7/16 | 11 | 5/16 | 8 | 179.00 | YC548 | 0113C | 132.00 |
| TBG005 | 0290MC | 8.5 | 30 | 762 | 1/2 | 13 | 3/8 | 10 | 219.00 | TBF983 | 0213C | 178.00 |
| TBG041 | 0390MC | 12.9 | 36 | 914 | 9/16 | 14 | 7/16 | 11 | 264.00 | TBG019 | 0313C | 184.00 |
| TBG082 | 0590MC | 17.2 | 42 | 1067 | 11/16 | 18 | 1/2 | 13 | 356.00 | TBG060 | 0513C | 219.00 |

GENERAL PURPOSE CENTRE CUT BOLT CUTTERS

- Series 2000 bolt cutter
- Drop-forged jaws with centre-cut blades
- Heat treated for wear resistance and long cutting life
- Cuts soft, and medium/hard materials
- Maximum hardness of material to be cut: Brinell 300/Rockwell C31
- Toggle joints turn 50 lbs. hand pressure to 4000 lbs. of cutting pressure
- Precision cast, 1-piece, aluminum alloy handles with rubber grips

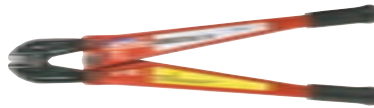

H.K. Porter

| Model No. | Mfg. No. | Wt. lbs. | Overall Length | | Cutting Capacity | | | | Replacement Cutterhead | | | |
|-----------|----------|----------|----------------|-----|--|----|--|----|------------------------|-----------|----------|-------------|
| | | | | | Soft and Medium Hard Materials (Up to Brinell 200, Rockwell C15) | | Hard Materials (Up to Brinell 300, Rockwell C31) | | Price /Each | Model No. | Mfg. No. | Price /Each |
| QH783 | 0090AC | 2.4 | 18 | 457 | 3/8 | 10 | 5/16 | 8 | 97.50 | TBF923 | 0013AC | 55.90 |
| QG952 | 0190AC | 4 | 24 | 610 | 7/16 | 11 | 3/8 | 10 | 131.00 | TBF945 | 0113AC | 58.50 |

INDUSTRIAL GRADE CLIPPER CUT CUTTERS

- All-purpose jaws with clipper-cut blades for close or flush cutting
- Not for cutting hard materials
- Maximum hardness of material to be cut: Brinell 300/Rockwell C31
- Lockplate keeps jaws from loosening
- Toggle joints turn 50 lbs. hand pressure to 4000 lbs. cutting pressure
- Screw-type adjustment realigns edges



H.K. Porter

| Model No. | Mfg. No. | Wt. lbs. | Overall Length | | Cutting Capacity | | | | Replacement Cutterhead | | | |
|-----------|----------|----------|----------------|-----|--|----|--|----|------------------------|-----------|----------|-------------|
| | | | | | Soft and Medium Hard Materials (Up to Brinell 200, Rockwell C15) | | Hard Materials (Up to Brinell 300, Rockwell C31) | | Price /Each | Model No. | Mfg. No. | Price /Each |
| TBG121 | 1490MNE | 2.75 | 14 | 356 | 5/16 | 8 | 1/4 | 6 | 196.00 | TBG110 | 1413NE | 119.00 |
| TBF934 | 0090MNE | 3.5 | 18 | 457 | 3/8 | 10 | 5/16 | 8 | 198.00 | TBF925 | 0013NE | 115.00 |
| TBF971 | 0190MNE | 5.25 | 24 | 610 | 7/16 | 11 | 3/8 | 10 | 216.00 | TBF950 | 0113NE | 139.00 |
| TBG008 | 0290MNE | 8.5 | 30 | 762 | 1/2 | 13 | 7/16 | 11 | 293.00 | TBF987 | 0213NE | 189.00 |
| TBG046 | 0390MNE | 12.9 | 36 | 914 | 9/16 | 14 | 1/2 | 13 | 334.00 | TBG025 | 0313NE | 207.00 |

GENERAL PURPOSE CENTRE CUT CUTTERS

- All-purpose jaws with centre-cut blades
- Cuts soft, medium, and hard metals
- Maximum hardness of material to be cut: Brinell 455/Rockwell C48
- Lockplate keeps jaws from loosening
- Toggle joints turn 50 lbs. hand pressure to 4000 lbs. cutting pressure
- Screw-type adjustment realigns edges
- Strong, lightweight fiberglass handles
- Popular cutter



H.K. Porter

| Model No. | Mfg. No. | Wt. lbs. | Overall Length | | Cutting Capacity | | | | Replacement Cutterhead | | | |
|-----------|----------|----------|----------------|-----|--|----|--|----|------------------------|-----------|----------|-------------|
| | | | | | Soft and Medium Hard Materials (Up to Brinell 200, Rockwell C15) | | Hard Materials (Up to Brinell 455, Rockwell C48) | | Price /Each | Model No. | Mfg. No. | Price /Each |
| TBF933 | 0090FC | 3.5 | 18 | 464 | 3/8 | 10 | 1/4 | 6 | 228.00 | TBF924 | 0013C | 108.00 |
| TBF963 | 0190FC | 4.5 | 24 | 622 | 7/16 | 11 | 5/16 | 8 | 262.00 | YC548 | 0113C | 132.00 |
| TBG001 | 0290FC | 7.5 | 30 | 775 | 1/2 | 13 | 3/8 | 10 | 319.00 | TBF983 | 0213C | 178.00 |
| TBG037 | 0390FC | 11.5 | 36 | 927 | 9/16 | 14 | 7/16 | 11 | 379.00 | TBG019 | 0313C | 184.00 |

KNIVES, SCISSORS & BOLT CUTTERS

HEAVY-DUTY CUTTERS

- Recommended for the most demanding hand cutting applications
- Heavy-duty straps support the jaws
- Maximum hardness of material to be cut: Brinell 455/Rockwell C48
- Lockplate keeps jaws from loosening
- Toggle joints turn 50 lbs. hand pressure to 4000 lbs. cutting pressure
- Screw-type adjustment realigns edges
- Available with tubular steel or lightweight, fiberglass handles

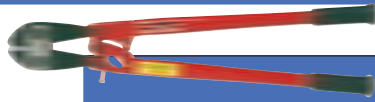

H.K. Porter®

| Model No. | Mfg. No. | Wt. lbs. | Overall Length | | Cutting Capacity (Up to Brinell 455, Rockwell C48) | | | Price /Each | Replacement Cutterhead | | |
|--|----------|----------|----------------|------|--|-------------|-----|-------------|------------------------|-----------|----------|
| | | | in. | mm | in. | mm | in. | | mm | Model No. | Mfg. No. |
| TBF968 | 0190MCX | 5.5 | 24 | 610 | 5/16 | 8 | | 284.00 | TBF946 | 0113CX | 179.00 |
| TBG006 | 0290MCX | 9.25 | 30 | 762 | 3/8 | 10 (#3 Bar) | | 310.00 | TBF985 | 0213CX | 223.00 |
| TBG043 | 0390MCX | 14.2 | 36 | 914 | 7/16 | 11 | | 392.00 | TBG020 | 0313CX | 269.00 |
| TBG084 | 0590MCX | 18.25 | 42 | 1067 | 1/2 | 13 (#4 Bar) | | 466.00 | TBG061 | 0513CX | 329.00 |
| LIGHTWEIGHT, FIBERGLASS HANDLES | | | | | | | | | | | |
| TBF964 | 0190FCX | 5.5 | 24 | 610 | 5/16 | 8 | | 353.00 | TBF946 | 0113CX | 179.00 |
| TBG039 | 0390FCX | 11.5 | 36 | 914 | 7/16 | 11 | | 474.00 | TBG020 | 0313CX | 269.00 |

BOLT CUTTER/CABLE CUTTERS

- Cuts soft, medium hard, and hard materials
- Cuts metal rod to 7/16" diameter
- Strap cuts wire rope to 1/4" diameter
- Maximum hardness of material to be cut: Brinell 455/Rockwell C48
- Lockplate keeps jaws from loosening
- Toggle joints turn 50 lbs. hand pressure to 4000 lbs. cutting pressure
- Screw-type adjustment realigns edges



H.K. Porter®

| Model No. | Mfg. No. | Wt. lbs. | Overall Length | | Cutting Capacity | | | | Price /Each | Replacement Cutterhead | | |
|-----------|----------|----------|----------------|-----|------------------|--------------|------|----|-------------|------------------------|---------|-----------|
| | | | in. | mm | Rockwell C31 | Rockwell C48 | in. | mm | | in. | mm | Model No. |
| TBF967 | 0190MCS | 5.5 | 24 | 610 | 7/16 | 11 | 5/16 | 8 | 297.00 | TBF949 | 0113MCS | 167.00 |

SHEAR TYPE CABLE CUTTERS

- Notched, shear-cut blades hold and lock cable in cutting position
- Cuts steel cable, coarse- or fine-stranded cable, or wire rope with minimal distortion
- Toggle joints turn 50 lbs. hand pressure to 4000 lbs. cutting pressure
- Screw-type adjustment realigns edges



H.K. Porter®

| Model No. | Mfg. No. | Wt. lbs. | Overall Length | | Cutting Capacity | | | | | | Price /Each | Replacement Cutterhead | | |
|-----------|----------|----------|----------------|------|------------------|-------------|-------|-----|-----|-----|-------------|------------------------|-----------|----------|
| | | | in. | mm | Rope | Steel Cable | Cable | in. | mm | in. | | mm | Model No. | Mfg. No. |
| TBG122 | 1490MTN | 2.75 | 14 | 356 | 1/4 | 6 | 1/4 | 6 | 1/4 | 6 | 284.00 | TBG111 | 1413TN | 144.00 |
| TBF972 | 0190MTN | 5 | 24 | 610 | 3/8 | 10 | 3/8 | 10 | 3/8 | 10 | 305.00 | YCS55 | 0113TN | 207.00 |
| TBG047 | 0390MTN | 12 | 36 | 914 | 5/8 | 16 | 5/8 | 16 | 5/8 | 16 | 451.00 | TBG026 | 0313TN | 293.00 |
| TBG088 | 0590MTN | 17 | 42 | 1067 | 3/4 | 19 | 3/4 | 19 | 3/4 | 19 | 549.00 | TBG067 | 0513TN | 338.00 |

REBAR CUTTERS & BENDERS

- Rugged contractor's tool
- Shear-cut blades
- Mounts easily on most flat surfaces to enhance leverage and increase safety

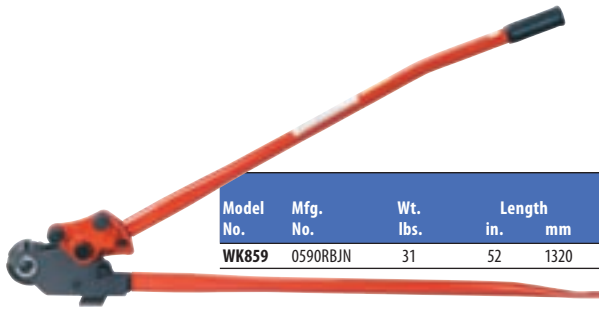

H.K. Porter®

| Model No. | Mfg. No. | Wt. lbs. | Length | | Maximum Capacity | Price /Each | Replacement Cutterhead | | | |
|-----------|----------|----------|--------|------|------------------|-------------|------------------------|--------|-----------|----------|
| | | | in. | mm | | | in. | mm | Model No. | Mfg. No. |
| WK859 | 0590RBJN | 31 | 52 | 1320 | 5/8 | 16 | 599.00 | TBG065 | 0513RBJ | 346.00 |

SLOTTED ANGLE IRON SHEARS

- Used to make braces, shelves, and tables
- Lightweight, portable shear
- Shear-cut blades
- Cuts pre-drilled and slotted angles up to 45° on either leg

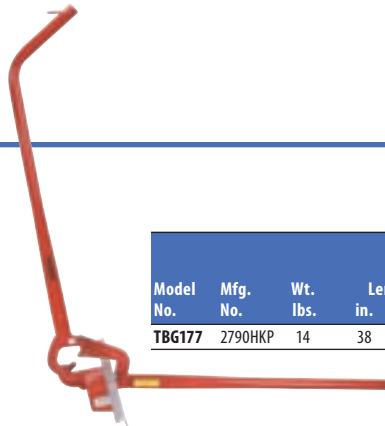

H.K. Porter®

| Model No. | Mfg. No. | Wt. lbs. | Length | | Capacity" | Price /Each | Replacement Blades | | | | | |
|-----------|----------|----------|--------|-----|----------------|-------------|--------------------|----------------|-------------|-----------|----------------|-------------|
| | | | in. | mm | | | Model No. | Lower Mfg. No. | Price /Each | Model No. | Upper Mfg. No. | Price /Each |
| TBG177 | 2790HKP | 14 | 38 | 965 | 3 x 1/12 x 1/8 | 627.00 | TBG175 | 2710HK | 99.90 | TBG176 | 2711HK | 169.00 |

HAMMERS, PRY BARS & PUNCHES



TJZ032



TJZ037



TJZ042



TJZ033



TJZ038



TJZ043



TJZ034



TJZ039



TJZ044



TJZ035



TJZ040



TJZ045



TJZ036



TJZ041



TJZ046

2-PC. HICKORY HANDLE HAMMER SETS

Includes:

- TJZ033 Hickory Handle, 16-oz. Claw Hammer
- TJZ034 Hickory Handle, 22-oz. Framing Hammer

Model No. TLV114

Price/Each \$37.35

4-PC. DEAD BLOW HAMMER SETS

Includes:

- TJZ035 Dead Blow, 8-oz. Hammer
- TJZ036 Dead Blow, 16-oz. Hammer
- TJZ037 Dead Blow, 24-oz. Hammer
- TJZ038 Dead Blow, 32-oz. Hammer

Model No. TLV113

Price/Each \$74.95

4-PC. BALL PEIN HAMMER SETS

Includes:

- TJZ039 Ball Pein, 8-oz. Hammer
- TJZ040 Ball Pein, 16-oz. Hammer
- TJZ041 Ball Pein, 24-oz. Hammer
- TJZ042 Ball Pein, 32-oz. Hammer

Model No. TLV112

Price/Each \$62.80

4-PC. RUBBER MALLET SET

Includes:

- TJZ043 Mallet, 16-oz., Black
- TJZ044 Mallet, 32-oz., Black
- TJZ045 Mallet, 16-oz., White
- TJZ046 Mallet, 32-oz., White

Model No. TLV115

Price/Each \$35.95

8-PC. UNIVERSAL HAMMER SETS

Includes:

- TJZ032 Tubular Handle, 16-oz. Claw Hammer
- TJZ034 Hickory Handle, 22-oz. Framing Hammer
- TJZ036 Dead Blow, 16-oz. Hammer
- TJZ038 Dead Blow, 32-oz. Hammer
- TJZ040 Ball Pein, 16-oz. Hammer
- TJZ042 Ball Pein, 32-oz. Hammer
- TJZ044 Mallet, 32-oz., Black
- TJZ045 Mallet, 16-oz., White

Model No. TLV116

Price/Each \$120.00

15-PC. ULTIMATE HAMMER SETS

Includes:

- TJZ032 Tubular Handle, 16-oz. Claw Hammer
- TJZ033 Hickory Handle, 16-oz. Claw Hammer
- TJZ034 Hickory Handle, 22-oz. Framing Hammer
- TJZ035 Dead Blow, 8-oz. Hammer
- TJZ036 Dead Blow, 16-oz. Hammer
- TJZ037 Dead Blow, 24-oz. Hammer
- TJZ038 Dead Blow, 32-oz. Hammer
- TJZ039 Ball Pein, 8-oz. Hammer
- TJZ040 Ball Pein, 16-oz. Hammer
- TJZ041 Ball Pein, 24-oz. Hammer
- TJZ042 Ball Pein, 32-oz. Hammer
- TJZ043 Mallet, 16-oz., Black
- TJZ044 Mallet, 32-oz., Black
- TJZ045 Mallet, 16-oz., White
- TJZ046 Mallet, 32-oz., White

Model No. TLV117

Price/Each \$203.00

aurora tools®

HAMMERS, PRY BARS & PUNCHES

ONE-PIECE DEAD BLOW HAMMERS

- Shot-filled canister absorbs shock
- Hot cast urethane with steel reinforced handle
- Non-marring
- Safety red

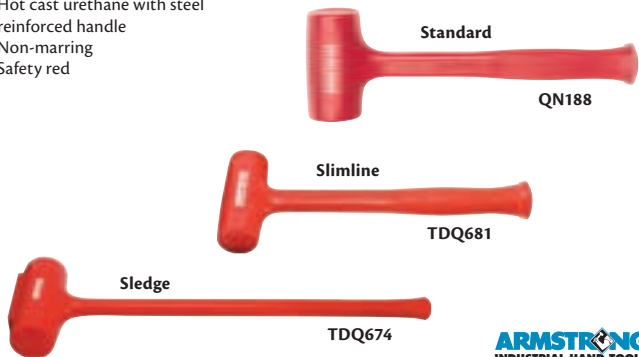

| Model No. | Mfg. No. | Weight Class | Overall Length" | Face Dia." | Head Length" | Price /Each |
|-----------|----------|--------------|-----------------|------------|--------------|-------------|
|-----------|----------|--------------|-----------------|------------|--------------|-------------|

STANDARD HEAD

| | | | | | | |
|-------|--------|--------|--------|-------|-------|-------|
| QN188 | 69-530 | 10 oz. | 10.125 | 1.250 | 3.125 | 36.40 |
| QN198 | 69-531 | 18 oz. | 11.250 | 1.750 | 3.750 | 44.80 |
| QN141 | 69-532 | 21 oz. | 12.750 | 2.000 | 4.125 | 51.90 |
| QN260 | 69-533 | 42 oz. | 14.375 | 2.250 | 4.625 | 73.20 |
| QN155 | 69-534 | 52 oz. | 15.250 | 2.750 | 5.375 | 99.90 |

SLIMLINE HEAD

| | | | | | | |
|--------|--------|--------|--------|-------|-------|-------|
| TDQ681 | 69-540 | 5 oz. | 9.375 | 0.875 | 2.875 | 34.20 |
| TDQ679 | 69-541 | 14 oz. | 10.625 | 1.250 | 4.187 | 42.80 |
| QD033 | 69-542 | 18 oz. | 12.125 | 1.500 | 4.250 | 46.30 |
| TDQ678 | 69-543 | 21 oz. | 12.125 | 1.750 | 5.187 | 57.70 |

SLEDGE HEAD

| | | | | | | |
|--------|--------|-----------|--------|-------|-------|--------|
| TDQ674 | 69-550 | 5 lbs. | 20.000 | 2.750 | 7.000 | 134.00 |
| TDQ673 | 69-551 | 8 lbs. | 30.000 | 2.750 | 7.000 | 198.00 |
| TDQ672 | 69-552 | 10.5 lbs. | 30.000 | 3.250 | 8.000 | 271.00 |
| TDQ671 | 69-554 | 11.5 lbs. | 36.000 | 3.250 | 8.000 | 289.00 |

DEAD BLOW HAMMERS

- 1-piece urethane construction
- Completely enclosed steel shank
- Shot-filled head
- Hi-Viz orange colour



| Model No. | Weight oz. | Price /Each |
|-----------|------------|-------------|
| TJZ035 | 8 | 16.30 |
| TJZ036 | 16 | 17.15 |
| TJZ037 | 24 | 19.30 |
| TJZ038 | 32 | 23.85 |

RUBBER MALLETS

- Hardwood handle
- Non-marking white rubber head (TJZ045 and TJZ046)



| Model No. | Weight oz. | Colour | Price /Each |
|-----------|------------|--------|-------------|
| TJZ043 | 16 | Black | 7.90 |
| TJZ044 | 32 | Black | 9.50 |
| TJZ045 | 16 | White | 8.95 |
| TJZ046 | 32 | White | 12.10 |

SOFT-FACE HAMMERS

- Solid fiberglass handle
- Fatigue-reducing grip design
- Tips are sold separately and available in different densities



| Model No. | Mfg. No. | Head | Diameter" | Head Length" | Handle Length" | Price /Each |
|-----------|----------|------------|-----------|--------------|----------------|-------------|
| UO320 | 69-001 | 5 oz. | 1 | 2 | 11 3/8 | 23.20 |
| UO321 | 69-003 | 8 oz. | 1 | 2 | 11 3/8 | 24.60 |
| UO322 | 69-009 | 12 oz. | 1 1/2 | 2 3/8 | 13 | 29.20 |
| UO323 | 69-011 | 1 lbs. | 1 1/2 | 4 1/2 | 13 | 43.10 |
| UO324 | 69-013 | 1 1/4 lbs. | 1 1/2 | 2 3/8 | 13 | 32.80 |
| UO325 | 69-017 | 1 1/4 lbs. | 2 | 2 1/2 | 13 | 37.80 |
| UO326 | 69-019 | 2 lbs. | 2 | 2 1/2 | 13 | 41.20 |
| UO327 | 69-025 | 2 lbs. | 2 1/2 | 3 1/4 | 15 | 53.10 |
| UO328 | 69-027 | 4 lbs. | 2 1/2 | 3 1/4 | 13 | 60.70 |
| UO329 | 69-031 | 3 1/2 lbs. | 3 | 3 3/4 | 14 | 74.20 |
| UO330 | 69-033 | 6 lbs. | 3 | 3 3/4 | 14 | 114.00 |

Note: Tips are not included with hammers. (See below).

TIPS FOR SOFT-FACE HAMMERS



| Model No. | Mfg. No. | Face" | Colour | Hardness | Price /Each |
|-----------|----------|-------|--------|-----------|-------------|
| TJ624 | 69-142 | 1 | Brown | Soft | 8.86 |
| TJ625 | 69-143 | 1 | Red | Medium | 8.82 |
| TJ626 | 69-145 | 1 | Green | Tough | 8.86 |
| TJ627 | 69-146 | 1 | Cream | Med. Hard | 9.15 |
| TJ628 | 69-148 | 1 | Black | Hard | 11.40 |
| TJ629 | 69-149 | 1 | Yellow | Ex. Hard | 11.40 |
| TJ630 | 69-152 | 1 1/2 | Brown | Soft | 13.30 |
| TJ631 | 69-153 | 1 1/2 | Red | Medium | 13.30 |
| TJ632 | 69-155 | 1 1/2 | Green | Tough | 13.30 |
| TJ633 | 69-156 | 1 1/2 | Cream | Med. Hard | 17.80 |
| TJ634 | 69-158 | 1 1/2 | Black | Hard | 21.30 |
| TJ635 | 69-159 | 1 1/2 | Yellow | Ex. Hard | 21.30 |
| TJ636 | 69-162 | 2 | Brown | Soft | 20.70 |
| TJ637 | 69-163 | 2 | Red | Medium | 20.40 |
| TJ638 | 69-165 | 2 | Green | Tough | 20.40 |
| TJ639 | 69-166 | 2 | Cream | Med. Hard | 29.90 |
| TJ640 | 69-168 | 2 | Black | Hard | 34.30 |
| TJ641 | 69-169 | 2 | Yellow | Ex. Hard | 34.30 |
| TJ642 | 69-172 | 2 1/2 | Brown | Soft | 35.80 |
| TJ643 | 69-173 | 2 1/2 | Red | Medium | 35.70 |
| TJ644 | 69-175 | 2 1/2 | Green | Tough | 35.70 |
| TJ645 | 69-176 | 2 1/2 | Cream | Med. Hard | 46.90 |
| TJ646 | 69-178 | 2 1/2 | Black | Hard | 55.30 |
| TJ647 | 69-179 | 2 1/2 | Yellow | Ex. Hard | 57.10 |
| TJ648 | 69-182 | 3 | Brown | Soft | 66.20 |
| TJ649 | 69-183 | 3 | Red | Medium | 54.10 |
| TJ650 | 69-185 | 3 | Green | Tough | 54.10 |
| TJ651 | 69-186 | 3 | Cream | Med. Hard | 76.50 |
| TJ652 | 69-188 | 3 | Black | Hard | 105.00 |
| TJ653 | 69-189 | 3 | Yellow | Ex. Hard | 105.00 |

HAMMERS, PRY BARS & PUNCHES



STEEL HANDLE HAMMERS

SOLID STEEL HAMMERS

- Fully polished head
- Cushion grip handle



| Model No. | Mfg. No. | Type | Head oz. | Price /Each |
|-----------|----------|------|----------|-------------|
| WJ145 | 600-5020 | Claw | 20 | 27.09 |

TUBULAR HANDLE HAMMERS

- 1.4 mm hardened tubular steel shaft
- Fully polished heat-treated face with octagonal neck
- Shock-absorbing cushion grip handle
- Steel overstrike ring
- Meets ANSI standards



| Model No. | Type | Head oz. | Price /Each |
|-----------|------|----------|-------------|
| TJZ032 | Claw | 16 | 11.90 |

SOLID STEEL ANTI-SHOCK PREMIUM CURVED CLAW HAMMERS

- Anti-vibration feature helps absorb shock
- 1-piece forged solid steel construction
- Co-molded contoured handle for increased comfort and control
- High-luster, full polished finish
- Magnetic nail starter



| Model No. | Mfg. No. | Head oz. | Length" | Face | Price /Each |
|-----------|----------|----------|---------|----------|-------------|
| UQ988 | SS16CN | 16 | 12.875 | Polished | 33.20 |
| WJ190 | SS20CN | 20 | 13.75 | Polished | 37.10 |

SOLID STEEL ANTI-SHOCK PREMIUM RIPPING CLAW HAMMERS

- Anti-vibration feature helps absorb shock
- 1-piece forged solid steel construction
- Co-molded contoured handle for increased comfort and control
- High-luster, full polished finish
- Magnetic nail starter



| Model No. | Mfg. No. | Head oz. | Length" | Face | Price /Each |
|-----------|----------|----------|---------|----------|-------------|
| WJ191 | SS16RN | 16 | 12.875 | Polished | 33.20 |
| TJ561 | SS20RN | 20 | 13.75 | Polished | 37.10 |
| UQ989 | SS22RN | 22 | 15.875 | Polished | 42.70 |
| TBH515 | SS28RN | 28 | 16 | Polished | 47.20 |

SOLID STEEL BRICK HAMMERS

- Solid steel for extra strength
- Forged handle and head
- Sharp cutting bit
- Cushion grip for extra comfort



| Model No. | Mfg. No. | Head oz. | Overall Length" | Price /Each |
|-----------|----------|----------|-----------------|-------------|
| WJ194 | SS20BHN | 20 | 11 | 36.90 |

SCALING HAMMERS

- Forged head
- Durable, black epoxy powder paint finish on head
- Red hickory handle
- PermaBond® construction between head and handle



| Model No. | Mfg. No. | Head wt. oz. | Overall Length" | Price /Each |
|-----------|----------|--------------|-----------------|-------------|
| TJ587 | 11530 | 16 | 13 | 28.50 |

WOOD HANDLE HAMMERS

HICKORY HANDLE HAMMERS

- Large natural colour, American hickory handle
- Extra tough, heat-treated fully polished head
- Extra large striking face
- Natural shock absorbing qualities of natural wood
- Meets ANSI standards



| Model No. | Type | Head oz. | Price /Each |
|-----------|---------|----------|-------------|
| TJZ033 | Claw | 16 | 14.50 |
| TJZ034 | Framing | 22 | 22.85 |

PREMIUM RED HICKORY HANDLE HAMMERS

- High-luster, full-polished
- PermaBond® construction between head and handle
- Factory balanced



| Model No. | Mfg. No. | Head oz. | Type | Price /Each |
|-----------|----------|----------|--------------|-------------|
| TJ575 | 11438 | 13 | Curved claw | 26.40 |
| TJ576 | 11436 | 16 | Curved claw | 26.90 |
| TJ577 | 11435 | 20 | Curved claw | 28.50 |
| TBH418* | 11439 | 22 | Ripping claw | 31.40 |

* Ripping claw (straight claw)

FIBERGLASS HANDLE HAMMERS

PREMIUM RIPPING CLAW HAMMERS

- Octagon-shaped neck
- Virtually unbreakable fiberglass handle
- Contoured handle for increased comfort
- PermaBond® construction between head and handle



| Model No. | Mfg. No. | Head oz. | Length" | Face | Price /Each |
|-----------|----------|----------|---------|-----------|-------------|
| TBH413 | 11414N | 22 | 13 1/2 | Polished | 33.60 |
| TJ571 | 11415N | 16 | 13 | Polished | 29.30 |
| TJ573 | 11416N | 22 | 15 | Polished | 36.20 |
| TJ574 | 11417N | 22 | 15 | Checkered | 37.30 |
| TJ572 | 11420N | 20 | 13 | Polished | 31.80 |

FIBERGLASS HANDLE HAMMERS

- Shock-absorbing fiberglass shaft
- Cushion-grip handle



| Model No. | Mfg. No. | Type | Head oz. | Price /Each |
|-----------|----------|------|----------|-------------|
| WJ146 | 600-3316 | Claw | 16 | 12.20 |

PREMIUM CURVED CLAW HAMMERS

- Octagon-shaped neck
- Virtually unbreakable fiberglass handle
- Contoured handle for increased comfort
- PermaBond® construction between head and handle



| Model No. | Mfg. No. | Head oz. | Length" | Face | Price /Each |
|-----------|----------|----------|---------|----------|-------------|
| TJ569 | 11402N | 16 | 13 | Polished | 29.50 |
| TJ568 | 11403N | 13 | 12 1/2 | Polished | 28.10 |
| TJ570 | 11400N | 20 | 13 | Polished | 31.80 |

ANTI-VIBRATION NAIL HAMMERS

- Patented Wavex waves significantly reduce harmful shock
- Polished alloy steel head
- Tough jacketed shaft protects hammer in case of overstrike
- Extra soft ergonomic grip
- Model TDU804 features a precision milled face



| Model No. | Mfg. No. | Head oz. | Type | Face | Price /Each |
|-----------|----------|----------|------|--------|-------------|
| TDU801 | 600-8016 | 16 | claw | Smooth | 20.27 |
| TDU802 | 600-8020 | 20 | Claw | Smooth | 20.86 |
| TDU803 | 600-8120 | 20 | Rip | Smooth | 21.58 |
| TDU804 | 600-8322 | 22 | Rip | Milled | 24.36 |

HAMMERS, PRY BARS & PUNCHES

BALL PEIN HAMMERS

- Kiln-dried hickory handle
- High quality construction
- Natural shock-absorbing qualities of natural wood
- Meets ANSI standards



aurora tools®

| Model No. | Weight oz. | Price/Each |
|-----------|------------|------------|
| TJZ039 | 8 | 11.70 |
| TJZ040 | 16 | 14.50 |

| Model No. | Weight oz. | Price/Each |
|-----------|------------|------------|
| TJZ041 | 24 | 17.60 |
| TJZ042 | 32 | 22.35 |

BALL PEIN HAMMERS

- Ground, black head
- Polished poles and peins
- Quality, hickory handle
- Permabond® construction between head and handle



Plumb®

| Model No. | Mfg. No. | Head Wt. oz | Overall Length" | Price /Each |
|-----------|----------|-------------|-----------------|-------------|
| TBH422 | 11494 | 4 | 10 1/2 | 18.10 |
| TBH424 | 11496 | 8 | 11 1/4 | 20.50 |
| TBH425 | 11497 | 12 | 11 1/4 | 21.10 |
| TBH426 | 11498 | 16 | 12 3/4 | 21.10 |

| Model No. | Mfg. No. | Head Wt. oz | Overall Length" | Price /Each |
|-----------|----------|-------------|-----------------|-------------|
| TBH427 | 11499 | 20 | 12 3/4 | 22.40 |
| TBH430 | 11520 | 24 | 15 | 22.90 |
| TBH431 | 11521 | 32 | 15 | 24.20 |
| TBH432 | 11522 | 40 | 15 | 25.30 |

COPPER HAMMERS

- Soft non-marring head
- Ideal for driving bushings and gears
- Hickory handle



ARMSTRONG INDUSTRIAL HAND TOOLS

| Model No. | Mfg. No. | Weight Class lbs. | Length" | Wt. lbs. | Price /Each |
|-----------|----------|-------------------|---------|----------|-------------|
| U0348 | 69-480 | 1 1/2 | 13 7/16 | 1.98 | 65.30 |
| U0349 | 69-485 | 2 | 13 1/2 | 2.34 | 69.20 |

BRASS HAMMERS

- Fiberglass handle
- Soft brass head
- Surface protective, non-sparking, non-marring
- Absorbs blows and reduces rebound



ARMSTRONG INDUSTRIAL HAND TOOLS

| Model No. | Mfg. No. | Weight Class lbs. | Face Dia." | Length" | Wt. lbs. | Price /Each |
|-----------|----------|-------------------|------------|---------|----------|-------------|
| U0355 | 69-513 | 1.5 | 1 1/16 | 12 | 1.95 | 64.40 |
| U0356 | 69-515 | 2.5 | 1 1/2 | 12 | 2.68 | 119.00 |
| U0357 | 69-517 | 4 | 1 7/8 | 12 | 3.94 | 196.00 |

SLIDE SLEDGE® HAMMERS

- Safer and more accurate
- Eliminates inaccurate sledge hammer swings
- Each Slide Sledge® includes a single 2" pin driver
- Other pin driver tips available

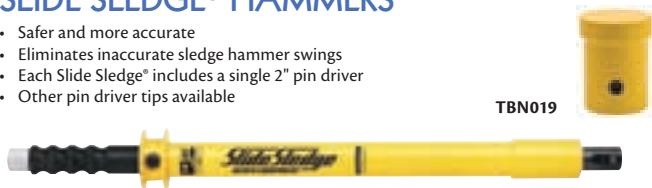

TBN019

TEAM Slide Sledge

| Model No. | Mfg. No. | Description | Price /Each |
|-----------|----------|---|-------------|
| TNB017 | 211103 | 9 lbs./30" Hammer with a 2" Pin Driver Tip | 836.00 |
| TNB018 | 211203 | 13 lbs./46" Hammer with a 2" Pin Driver Tip | 856.00 |
| TNB019 | 211301 | 14 lbs./30" BMF Hammer with a 2" Pin Driver Tip | 950.00 |
| TNB020 | 211401 | 21 lbs./46" BMF Hammer with a 2" Pin Driver Tip | 1020.00 |

OPTIONAL TIPS

| Model No. | Mfg. No. | Description | Price /Each |
|-----------|----------|------------------------------|-------------|
| TNB021 | 213101 | Pin Driver - 1/2" Diameter | 153.00 |
| TNB022 | 213102 | Pin Driver - 7/8" Diameter | 126.00 |
| TNB023 | 213103 | Pin Driver - 1 1/4" Diameter | 117.00 |
| TNB024 | 213104 | Pin Driver - 2" Diameter | 65.10 |
| TNB025 | 213105 | Pin Driver - 2 1/2" Diameter | 86.90 |
| TNB026 | 213106 | Pin Driver - 3" Diameter | 94.80 |

ANTI-VIBRATION BALL PEIN HAMMERS

- Patented Wavex waves significantly reduce harmful shock
- Polished alloy steel head
- Extra-large striking surface
- Tough jacket shaft protects hammer in case of overstrike
- Extra soft ergonomic grip



FULLER

| Model No. | Mfg. No. | Head oz. | Price /Each |
|-----------|----------|----------|-------------|
| TDU805 | 611-8016 | 16 | 17.09 |
| TDU806 | 611-8024 | 24 | 21.88 |
| TDU807 | 611-8032 | 32 | 23.57 |

BALL PEIN HAMMERS

- Heads are drop forged
- Hollow core fiberglass handle for balance
- Absorbs shock better than solid fiberglass

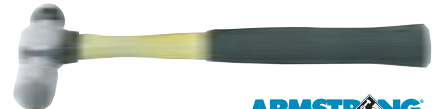

ARMSTRONG INDUSTRIAL HAND TOOLS

| Model No. | Mfg. No. | Weight Class | Length" | Wt. lbs. | Price /Each |
|-----------|----------|--------------|---------|----------|-------------|
| U0335 | 69-404 | 8 oz. | 12 1/2 | 1.00 | 45.40 |
| U0336 | 69-406 | 12 oz. | 13 | 1.26 | 49.50 |
| U0337 | 69-408 | 1 lbs. | 13 | 1.47 | 51.40 |
| U0338 | 69-410 | 1 1/2 lbs. | 14 1/2 | 2.07 | 56.50 |
| U0339 | 69-412 | 2 lbs. | 14 3/4 | 2.63 | 61.60 |

BALL PEIN HAMMERS - FIBERGLASS

- Rust-resistant, forged black head with polished poles and peins
- Professional quality fiberglass handle
- Permabond® construction between head and handle
- Comfortable black cushion grip



Plumb®

| Model No. | Mfg. No. | Head oz. | Weight grams | Overall Inch | Length mm | Price /Each |
|-----------|----------|----------|--------------|--------------|-----------|-------------|
| TJ594 | 11426 | 16 | 454 | 12 3/4 | 324 | 27.20 |
| TJ596 | 11428 | 24 | 681 | 15 | 377 | 29.60 |
| TJ597 | 11429 | 32 | 908 | 15 | 377 | 30.10 |

INDESTRUCTIBLE HANDLE HAMMERS

- Indestructible handle is made up with spring steel bars, encased in rubber, running through the handle
- Spring steel bars are locked into the hammer head with steel locking plates, ensuring it never dislodges
- Ergonomic rubber grip handle absorbs impact and vibration reducing user fatigue
- Will not break, bend, or split even after repeated overstrikes
- Head is induction case hardened 52-56 HRC

aurora tools®

| Model No. | Head Weight lbs. | No. of Spring Steel Bars | Handle Length" | Price /Each |
|-----------|------------------|--------------------------|----------------|-------------|
|-----------|------------------|--------------------------|----------------|-------------|

| SLEDGE HAMMERS | | | | |
|----------------|----|---|----|--------|
| TYB494 | 6 | 6 | 24 | 125.00 |
| TYB495 | 8 | 6 | 24 | 137.00 |
| TYB496 | 8 | 6 | 30 | 147.00 |
| TYB497 | 10 | 6 | 30 | 163.00 |
| TYB498 | 12 | 6 | 30 | 183.00 |
| TYB499 | 14 | 6 | 30 | 188.00 |

| CLUB HAMMERS | | | | |
|--------------|---|---|----|-------|
| TYB492 | 4 | 4 | 12 | 68.20 |
| TYB493 | 4 | 4 | 16 | 82.95 |

TYB492

TYB494



HAMMERS, PRY BARS & PUNCHES

DOUBLE-FACED SLEDGE HAMMERS

- High-quality hickory handle
- Forged, new treated head
- Head secured with wood and steel wedges



| Model No. | Mfg. No. | Head lbs. | Face | Length" | Price /Each |
|-----------|----------|-----------|----------|---------|-------------|
| TV691 | D40104 | 4 | Polished | 16 | 31.50 |
| TV692 | D40304 | 6 | Polished | 32 | 41.90 |
| TV693 | D40404 | 8 | Polished | 32 | 47.00 |
| TV694 | D40504 | 10 | Polished | 36 | 58.00 |
| TV695 | D40604 | 12 | Polished | 36 | 65.70 |

CLUB HAMMERS

- High-quality hickory handle
- Forged, new treated head
- Head secured with wood and steel wedges



| Model No. | Mfg. No. | Head lbs. | Face | Length" | Price /Each |
|-----------|----------|-----------|----------|---------|-------------|
| TV688 | D10004 | 2.5 | Polished | 10 | 25.00 |
| TV689 | D10204 | 4 | Polished | 16 | 29.70 |

DOUBLE-FACED, FIBERGLASS SLEDGE HAMMERS

- High-quality fiberglass handle
- Forged, new treated head
- Head secured with epoxy



| Model No. | Mfg. No. | Head lbs. | Face | Length" | Price /Each |
|-----------|----------|-----------|----------|---------|-------------|
| TV698 | DF1034FG | 10 | Polished | 34 | 54.90 |

NAIL PULLERS WITH HANDLE

- Small nail puller
- Forged and tempered steel
- Comfortable hexagonal handle
- Ideal for hard-to-reach places



| Model No. | Mfg. No. | Overall Length" | Price /Each |
|-----------|----------|-----------------|-------------|
| TLZ697 | NP10 | 10 | 6.97 |

BLACKSMITH HAND HAMMERS

- Quality, steel forged head, hardened and tempered
- Durable, flat black finish on head
- Hickory handle



| Model No. | Mfg. No. | Head wt. oz. | Overall Length" | Price /Each |
|-----------|----------|--------------|-----------------|-------------|
| TBH433 | 11524 | 40 | 14 | 29.50 |

HAND DRILLING HAMMERS

- Black forged head
- Hickory handle



| Model No. | Mfg. No. | Head wt. oz. | Overall length" | Price /Each |
|-----------|----------|--------------|-----------------|-------------|
| TBH448 | 11649 | 48 | 10 3/4 | 35.40 |

ACTION BARS

- High quality heat-treated carbon steel
- Edges are specially bevelled for pulling, lifting and scraping
- Baked paint finish



| Model No. | Size" | Colour | Price /Each |
|-----------|----------------|--------|-------------|
| TJZ047 | 13 1/2 x 1 3/8 | Black | 7.85 |

SCRAPER & PRY BARS

- Heat-treated carbon steel
- Bevelled edges
- Slotted at one end for nail removal, scraper at other end to remove paint, coatings and accumulation
- Baked paint finish



| Model No. | Mfg. No. | Overall Length" | Price /Each |
|-----------|----------|-----------------|-------------|
| TDP844 | 615-5514 | 9 1/2 | 8.61 |

GOOSENECK WRECKING BARS

- High quality steel
- Hexagon shank
- Bevelled edges for pulling and lifting



| Model No. | Diameter" | Length" | Weight lbs. | Price /Each |
|-----------|-----------|---------|-------------|-------------|
| TJZ048 | 5/8 | 18 | 1.9 | 7.75 |
| TJZ049 | 3/4 | 24 | 3.0 | 12.45 |
| TJZ050 | 3/4 | 30 | 4.0 | 17.25 |
| TJZ051 | 3/4 | 36 | 5.0 | 20.95 |

CRESCENT® BULL BAR™ DECKING REMOVAL TOOL

- For every home renovation project, DIYers and tradesmen alike can count on the dual claw wrecking bar
- The double fork design provides balanced lift on both sides of the nail
- Boards are removed faster, cleaner and with less effort
- Rugged indexing joint allows for maximum flexibility and increased leverage
- Precision tips designed for fast access between boards and reduced damage for reclaiming materials
- Gripping teeth on forks assist in preventing board slippage

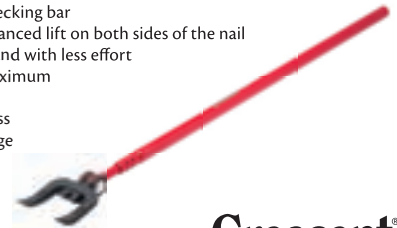

| Model No. | Mfg. No. | Width" | Overall Length" | Price /Each |
|-----------|----------|--------|-----------------|-------------|
| TY0563 | DKB44X | 5-1/2 | 44 | 147.00 |

EXTENDABLE PRY BARS

- Extends for greater access and leverage and collapses so you can store it securely in your tool box
- Knurled handle provides a better overall grip
- Indexible head turns 180° for greater leverage
- Grooved foot gives added traction
- Exceeds ANSI requirements for proven strength



| Model No. | Mfg. No. | Description | Price /Each |
|-----------|----------|-------------------------------|-------------|
| TLV416 | 82220 | 18" to 29" Extendable Pry Bar | 106.00 |
| TLV417 | 82248 | 29" to 48" Extendable Pry Bar | 178.00 |

HAMMERS, PRY BARS & PUNCHES

PRY BARS



ARMSTRONG
INDUSTRIAL HAND TOOLS

| Model No. | Mfg. No. | Tip Width" | Stock Size" | Blade Length" | OAL" | Wt. lbs. | Price /Each |
|-----------|----------|------------|-------------|---------------|------|----------|-------------|
| U0454 | 70-531 | 5/8 | 3/8 | 7 | 12 | 0.47 | 28.60 |
| U0455 | 70-533 | 5/8 | 3/8 | 12 | 17 | 0.75 | 36.10 |
| U0456 | 70-535 | 11/16 | 1/2 | 18 | 25 | 1.72 | 48.20 |
| U0457 | 70-537 | 11/16 | 1/2 | 24 | 31 | 2.28 | 59.90 |
| U0458 | 70-539 | 1 | 7/8 | 28 | 36 | 3.69 | 114.00 |

4-PC. PRY BAR SETS

- Blade lengths included:
3/8" x 7", 3/8" x 12",
1/2" x 18", 1/2" x 24
- Approximate weight: 5.51 lbs.

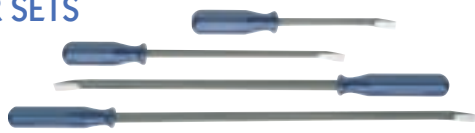

Model No. UO466 Mfg. No. 70-579
Price/Each \$161.00

ARMSTRONG
INDUSTRIAL HAND TOOLS

ROLLING HEAD BARS



ARMSTRONG
INDUSTRIAL HAND TOOLS

| Model No. | Mfg. No. | Stock Size" | Length" | Wt. lbs. | Price /Each |
|-----------|----------|-------------|---------|----------|-------------|
| U0451 | 70-517 | 3/8 | 9 | 0.29 | 27.20 |
| U0452 | 70-519 | 1/2 | 15 | 0.87 | 37.10 |
| U0453 | 70-521 | 5/8 | 18 | 1.59 | 43.60 |

ALIGNING PRY BARS



ARMSTRONG
INDUSTRIAL HAND TOOLS

| Model No. | Mfg. No. | Stock Size" | Length" | Wt. lbs. | Price /Each |
|-----------|----------|-------------|---------|----------|-------------|
| U0445 | 70-501 | 1/2 | 14 | 0.78 | 24.30 |
| U0446 | 70-503 | 5/8 | 16 | 1.45 | 33.90 |
| U0447 | 70-505 | 3/4 | 24 | 3.08 | 45.20 |
| U0448 | 70-507 | 7/8 | 30 | 4.78 | 76.60 |
| U0449 | 70-509 | 7/8 | 46 | 7.33 | 85.30 |
| U0450 | 70-511 | 1 1/16 | 54 | 10.45 | 110.00 |

4-PC. ALIGNING/ROLLING HEAD SETS

- Kit contains aligning pry bars in stock sizes 5/8" and 3/4" and rolling head bars in stock sizes 1/2" and 5/8"
- Approximate weight: 7.04 lbs.



Model No. TDQ979 Mfg. No. 70-578
Price/Each \$151.00

ARMSTRONG
INDUSTRIAL HAND TOOLS

IRWIN MARPLES® BLUE CHIP® WOODWORKING CHISELS

- Long blade and handle for increased leverage
- For either hand or mallet work
- High carbon steel
- Polypropylene handle

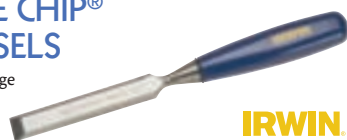

IRWIN
Industrial Tools

| Model No. | Mfg. No. | Blade Width" | Price /Each |
|-----------|-------------|--------------|-------------|
| TBQ831 | M444/-1/8N | 1/8 | 11.70 |
| TBQ830 | M444/-1/4N | 1/4 | 11.70 |
| TBQ833 | M444/-3/8N | 3/8 | 11.90 |
| TBQ829 | M444/-1/2N | 1/2 | 12.50 |
| TBQ834 | M444/-5/8N | 5/8 | 13.10 |
| TBQ832 | M444/-3/4N | 3/4 | 14.10 |
| TBR087 | M444/-1N | 1 | 15.40 |
| TBQ665 | M444/1-1/4N | 1 1/4 | 17.10 |
| TBQ664 | M444/1-1/2N | 1 1/2 | 19.50 |
| TBR088 | M444/2N | 2 | 25.90 |

SETS

| Model No. | Mfg. No. | Description | Sizes" | Price /Each |
|-----------|----------|----------------|----------------------------|-------------|
| TGZ494 | M444/S4 | 4-Pc Set | 1/4, 1/2, 3/4, 1 | 51.30 |
| TGZ496 | M444/SB6 | 6-Pc Boxed Set | 1/4, 3/8, 1/2, 5/8, 3/4, 1 | 95.40 |

PUNCH & CHISEL HOLDERS

- Holds punches and chisels up to 1 1/16" hex stock
- Protects against hand injury
- Tri-oval shaped handle conforms to the hand, increasing comfort
- Warning is prominently visible
- "V" shaped head traps punch/chisel reducing risk of injury



ARMSTRONG
INDUSTRIAL HAND TOOLS

| Model No. | Mfg. No. | Contracted Length" | Expanded Length" | Wt. lbs. | Price /Each |
|-----------|----------|--------------------|------------------|----------|-------------|
| TDQ546 | 70-000 | 7.5 | 8.75 | 0.72 | 29.50 |

COLD CHISELS

- Individually forged from high quality alloy steel
- Manufactured to the highest safety standards
- Precisely ground cutting edge is induction hardened to 52-58 HRC
- Striking head is hardened to 42 HRC to prevent splintering during use



6-PC. COLD CHISEL SET

Set includes sizes: 1/4", 5/16", 3/8", 1/2", 5/8", and 3/4"

Model No. TLZ420
Price/Each \$44.45

aurora tools

| Model No. | Width of Cut" | Stock Size" | Overall Length" | Price /Each |
|-----------|---------------|-------------|-----------------|-------------|
| TLZ395 | 1/4 | 1/4 | 5 | 5.25 |
| TLZ396 | 5/16 | 1/4 | 5 | 6.35 |
| TLZ397 | 3/8 | 5/16 | 5 1/2 | 8.55 |
| TLZ398 | 1/2 | 7/16 | 6 | 8.55 |
| TLZ399 | 5/8 | 1/2 | 6 1/2 | 9.30 |
| TLZ400 | 3/4 | 5/8 | 7 | 15.35 |
| TLZ556 | 7/8 | 3/4 | 7 1/2 | 18.65 |

COLD CHISEL SETS

5-PC. COLD CHISEL SET

- Includes sizes: 5/16", 3/8", 7/16", 1/2", 5/8" and a vinyl roll, Mfg. No. 29-407
- Approximate weight: 1.19 lbs.

Model No. TDQ543 Mfg. No. 70-564
Price/Each \$58.90



7-PC. COLD CHISEL SET

- Includes sizes: 5/16", 3/8", 7/16", 1/2", 5/8", 3/4", 7/8" and a vinyl roll, Mfg. No. 29-406
- Approximate weight: 2.80 lbs.

Model No. TDQ542 Mfg. No. 70-562
Price/Each \$89.90



Ask us about volume prices!
In many cases you will benefit from quantity prices.



HAMMERS, PRY BARS & PUNCHES

COLD CHISELS



ARMSTRONG
INDUSTRIAL HAND TOOLS

| Model No. | Mfg. No. | Width of Cut" | Stock Size" | Length" | Wt. lbs. | Price /Each |
|-----------|----------|---------------|-------------|---------|----------|-------------|
| U0410 | 70-301 | 1/4 | 1/4 | 4 3/4 | 0.08 | 8.48 |
| U0411 | 70-303 | 5/16 | 5/16 | 5 | 0.12 | 8.66 |
| U0412 | 70-305 | 3/8 | 5/16 | 5 1/4 | 0.13 | 9.02 |
| U0413 | 70-307 | 7/16 | 3/8 | 5 1/2 | 0.16 | 9.19 |
| U0414 | 70-309 | 1/2 | 3/8 | 6 | 0.19 | 10.80 |
| U0415 | 70-311 | 5/8 | 1/2 | 6 1/2 | 0.33 | 11.90 |
| U0416 | 70-313 | 3/4 | 5/8 | 7 | 0.60 | 15.40 |
| U0417 | 70-315 | 7/8 | 3/4 | 7 1/2 | 0.91 | 22.60 |
| U0418 | 70-317 | 1 | 7/8 | 8 | 1.33 | 24.30 |
| U0419 | 70-319 | 1 1/8 | 7/8 | 8 | 1.39 | 27.20 |

EXTRA LONG COLD CHISELS



ARMSTRONG
INDUSTRIAL HAND TOOLS

| Model No. | Mfg. No. | Width of Cut" | Stock Size" | Length" | Wt. lbs. | Price /Each |
|-----------|----------|---------------|-------------|---------|----------|-------------|
| U0420 | 70-347 | 5/8 | 1/2 | 12 | 0.68 | 17.40 |
| U0421 | 70-353 | 3/4 | 5/8 | 12 | 1.05 | 18.20 |
| U0423 | 70-357 | 3/4 | 5/8 | 18 | 1.42 | 37.90 |
| U0424 | 70-361 | 7/8 | 3/4 | 12 | 1.54 | 29.90 |
| U0425 | 70-367 | 1 | 7/8 | 12 | 2.08 | 37.50 |
| U0426 | 70-369 | 1 | 7/8 | 18 | 3.01 | 41.60 |

CAPE CHISELS



ARMSTRONG
INDUSTRIAL HAND TOOLS

| Model No. | Mfg. No. | Width of Cut" | Stock Size" | Length" | Wt. lbs. | Price /Each |
|-----------|----------|---------------|-------------|---------|----------|-------------|
| U0427 | 70-391 | 3/16 | 1/4 | 5 | 0.10 | 12.60 |
| U0428 | 70-393 | 7/32 | 5/16 | 5 | 0.10 | 12.80 |
| U0429 | 70-395 | 1/4 | 3/8 | 5 | 0.13 | 13.20 |
| U0430 | 70-397 | 5/16 | 3/8 | 5 3/4 | 0.19 | 14.70 |
| U0431 | 70-399 | 3/8 | 1/2 | 6 | 0.27 | 17.90 |

CENTRE PUNCHES



ARMSTRONG
INDUSTRIAL HAND TOOLS

| Model No. | Mfg. No. | Stock Size" | Length" | Wt. lbs. | Price /Each |
|-----------|----------|-------------|---------|----------|-------------|
| U0401 | 70-231 | 1/4 | 4 1/4 | 0.06 | 7.85 |
| U0402 | 70-233 | 5/16 | 4 1/2 | 0.08 | 7.26 |
| U0403 | 70-235 | 3/8 | 5 | 0.13 | 9.57 |
| WJ369 | 70-237 | 7/16 | 5 1/2 | 0.21 | 10.40 |
| U0404 | 70-239 | 1/2 | 6 | 0.28 | 10.30 |
| U0405 | 70-241 | 5/8 | 7 | 0.42 | 15.30 |

TOOL STEEL COLD CHISELS



ARMSTRONG
INDUSTRIAL HAND TOOLS

| Model No. | Mfg. No. | Width of Cut" | Stock Size" | Length" | Wt. lbs. | Price /Each |
|-----------|----------|---------------|-------------|---------|----------|-------------|
| TDQ550 | 70-325 | 3/8 | 5/16 | 5 1/2 | 0.13 | 17.40 |
| TDQ549 | 70-329 | 1/2 | 7/16 | 6 | 0.26 | 21.30 |
| TDQ548 | 70-331 | 5/8 | 1/2 | 6 1/2 | 0.37 | 23.30 |
| TDQ547 | 70-333 | 3/4 | 5/8 | 7 | 0.60 | 29.90 |
| TDQ545 | 70-335 | 7/8 | 3/4 | 7 1/2 | 0.90 | 40.60 |
| TDQ544 | 70-337 | 1 | 7/8 | 8 | 1.25 | 37.50 |

COLD CHISELS WITH GRIP GUARD

- Individually forged from high quality alloy steel
- Manufactured to the highest safety standards
- Precisely ground cutting edge is induction hardened to 52-58 HRC
- Striking head is hardened to 42 HRC to prevent splintering during use



TYB511

aurora tools

| Model No. | Width of Cut" | Stock Size" | Overall Length" | Price /Each |
|-----------|---------------|-------------|-----------------|-------------|
| TYB509 | 3/4 | 5/8 | 10 | 23.45 |
| TYB510 | 3/4 | 5/8 | 12 | 25.55 |
| TYB511 | 1 | 7/8 | 10 | 30.40 |
| TYB512 | 1 | 7/8 | 12 | 33.50 |

CENTRE PUNCHES

- Single piece construction with hexagonal shank increases durability
- Manufactured from high quality carbon steel
- Accurately hardened for increased service life
- Bevelled striking end to prevent breakage
- The working tips are centred and ground to 90° for increased marking efficiency



5-PC. CENTRE PUNCH SET

Set includes sizes: 5/64", 1/8", 5/32", 1/4", and 3/8"

Model No. TLZ423

Price/Each \$31.25

aurora tools

| Model No. | Point Diameter" | Stock Size" | Length" | Price /Each |
|-----------|-----------------|-------------|---------|-------------|
| TLZ415 | 5/64 | 1/4 | 3 1/2 | 5.15 |
| TLZ416 | 1/8 | 5/16 | 4 1/4 | 5.70 |
| TLZ417 | 5/32 | 3/8 | 5 | 5.70 |
| TLZ418 | 1/4 | 1/2 | 6 | 7.30 |
| TLZ419 | 3/8 | 5/8 | 6 1/4 | 9.65 |

PIN PUNCHES

- Ideal for driving out and removing already loosened pins and keys after initial movement by a starting punch
- Manufactured from high quality carbon steel
- Single piece construction with hexagonal shank increases durability
- Accurately hardened for increased service life



7-PC. PIN PUNCH SET

Set includes sizes:

1/16", 3/32", 1/8", 5/32", 3/16", 7/32", and 1/4"

Model No. TLZ421

Price/Each \$37.35

aurora tools

| Model No. | Point Diameter" | Stock Size" | Length" | Price /Each |
|-----------|-----------------|-------------|---------|-------------|
| TLZ401 | 1/16 | 1/4 | 4 | 4.70 |
| TLZ402 | 3/32 | 5/16 | 4 1/2 | 5.40 |
| TLZ403 | 1/8 | 5/16 | 4 3/4 | 5.80 |
| TLZ404 | 5/32 | 5/16 | 5 | 5.80 |
| TLZ405 | 3/16 | 5/16 | 5 1/4 | 5.80 |
| TLZ555 | 7/32 | 3/8 | 5 1/2 | 6.05 |
| TLZ406 | 1/4 | 3/8 | 5 3/4 | 6.55 |
| TLZ407 | 5/16 | 7/16 | 6 | 8.90 |

HAMMERS, PRY BARS & PUNCHES

PIN PUNCHES



ARMSTRONG
INDUSTRIAL HAND TOOLS

| Model No. | Mfg. No. | Point Dia." | Stock Size" | Length" | Wt. lbs. | Price /Each |
|-----------|----------|-------------|-------------|---------|----------|-------------|
| U0369 | 70-101 | 1/16 | 5/16 | 4-1/4 | 0.07 | 7.37 |
| U0370 | 70-103 | 3/32 | 5/16 | 4-3/4 | 0.08 | 7.77 |
| U0371 | 70-105 | 1/8 | 5/16 | 5 | 0.08 | 7.99 |
| U0372 | 70-107 | 5/32 | 5/16 | 5-1/4 | 0.08 | 9.25 |
| U0373 | 70-109 | 3/16 | 5/16 | 5-1/2 | 0.08 | 9.36 |
| U0374 | 70-129 | 7/32 | 3/8 | 7 | 0.16 | 11.20 |
| U0375 | 70-131 | 1/4 | 3/8 | 7 | 0.18 | 11.60 |
| U0376 | 70-133 | 5/16 | 1/2 | 7 | 0.30 | 14.20 |

TOOL STEEL LONG PIN PUNCHES



ARMSTRONG
INDUSTRIAL HAND TOOLS

| Model No. | Mfg. No. | Point Dia." | Stock Size" | Length" | Wt. lbs. | Price /Each |
|-----------|----------|-------------|-------------|---------|----------|-------------|
| TDQ699 | 70-041 | 1/8 | 5/16 | 8 | 0.12 | 11.40 |
| TDQ698 | 70-042 | 5/32 | 5/16 | 8 | 0.13 | 12.70 |
| TDQ697 | 70-043 | 3/16 | 3/8 | 8 | 0.16 | 13.70 |
| TDQ696 | 70-044 | 7/32 | 3/8 | 8 | 0.18 | 14.90 |
| TDQ695 | 70-045 | 1/4 | 3/8 | 8 | 0.19 | 15.50 |
| TDQ694 | 70-047 | 5/16 | 7/16 | 8 | 0.28 | 17.10 |
| TDQ688 | 70-049 | 3/8 | 1/2 | 8 | 0.38 | 17.80 |

DRIVE PIN PUNCHES FOR MACHINE SHOP & MOTOR SERVICE WORK

- Extra-long, measuring 8" (200 mm)
- Bodies are 4 1/2" (115 mm) long
- Drive pin sections are 3 1/2" (90 mm) long
- Well-proportioned, hardened, properly tempered
- Knurled grip
- Designed to withstand hard use in machine shop and motor service work
- The diameters of the punches are slightly under the sizes listed below



Starrett

| Model No. | Mfg. No. | Length" | Diameter" | Price /Each |
|-----------|----------|--|-----------|-------------|
| TBB472 | 51181 | 8 | 1/8 | 10.10 |
| TBB473 | 51182 | 8 | 3/16 | 10.10 |
| TBB474 | 51183 | 8 | 1/4 | 10.20 |
| TBB475 | 51184 | 8 | 5/16 | 10.20 |
| TBB476 | 51185 | 8 | 3/8 | 10.20 |
| TBB477 | 51186 | Set of 5 punches (1 of each size) in protective vinyl case | | 62.10 |
| TBB478 | 51187 | Set of 5 punches (1 of each size) in plain box | | 53.30 |

ROLL PIN PUNCHES



ARMSTRONG
INDUSTRIAL HAND TOOLS

| Model No. | Mfg. No. | Point Dia." | Stock Size" | Length" | Wt. lbs. | Price /Each |
|-----------|----------|-------------|-------------|---------|----------|-------------|
| WJ370 | 70-260 | 1/16 | 3/16 | 2 3/4 | 0.02 | 7.99 |
| WJ371 | 70-262 | 3/32 | 3/16 | 3 1/2 | 0.02 | 8.83 |
| WJ372 | 70-264 | 1/8 | 1/4 | 4 | 0.04 | 9.51 |
| WJ373 | 70-266 | 5/32 | 1/4 | 4 1/2 | 0.04 | 10.40 |
| WJ374 | 70-268 | 3/16 | 3/8 | 4 1/2 | 0.08 | 11.20 |
| WJ375 | 70-270 | 7/32 | 3/8 | 5 | 0.08 | 12.10 |
| WJ376 | 70-272 | 1/4 | 7/16 | 5 1/2 | 0.13 | 13.50 |
| WJ377 | 70-274 | 5/16 | 7/16 | 6 | 0.17 | 14.10 |
| WJ378 | 70-276 | 3/8 | 1/2 | 6 | 0.21 | 14.40 |
| WJ379 | 70-280 | 1/2 | 5/8 | 6 | 0.38 | 14.90 |

DRIFT PUNCHES

- Ideal for lining up holes in two or more pieces of metal and for drawing pins through various assemblies
- Manufactured from high quality carbon steel
- Single piece construction with hexagonal shank increases durability
- Accurately hardened for increased service life



7-PC. DRIFT PUNCH SET

Set includes sizes: 1/8", 5/32", 3/16", 7/32", 1/4", 5/16", and 3/8"

Model No. TLZ422
Price/Each \$90.75

aurora tools

| Model No. | Point Size" | Stock Size" | Length" | Price /Each |
|-----------|-------------|-------------|---------|-------------|
| TLZ408 | 1/8 | 5/16 | 8 | 8.00 |
| TLZ409 | 5/32 | 3/8 | 9 | 8.90 |
| TLZ410 | 3/16 | 1/2 | 10 | 11.25 |
| TLZ411 | 7/32 | 1/2 | 10 | 13.35 |
| TLZ412 | 1/4 | 5/8 | 12 | 15.95 |
| TLZ413 | 5/16 | 3/4 | 12 | 17.20 |
| TLZ414 | 3/8 | 3/4 | 15 | 22.15 |

DRIFT PUNCHES



ARMSTRONG
INDUSTRIAL HAND TOOLS

| Model No. | Mfg. No. | Point Dia." | Stock Size" | Length" | Wt. lbs. | Price /Each |
|-----------|----------|-------------|-------------|---------|----------|-------------|
| U0392 | 70-187 | 3/32 | 3/8 | 7 1/2 | 0.26 | 16.50 |
| U0393 | 70-189 | 1/8 | 3/8 | 8 | 0.29 | 16.70 |
| U0394 | 70-191 | 5/32 | 1/2 | 8 1/2 | 0.34 | 16.90 |
| U0395 | 70-193 | 3/16 | 1/2 | 9 | 0.38 | 17.40 |
| U0396 | 70-195 | 7/32 | 1/2 | 9 1/2 | 0.45 | 18.60 |
| U0397 | 70-197 | 1/4 | 5/8 | 11 | 0.68 | 18.50 |
| U0398 | 70-199 | 5/16 | 5/8 | 11 | 0.72 | 20.80 |
| U0399 | 70-201 | 3/8 | 3/4 | 11 | 0.76 | 26.20 |

LONG ALIGNING PUNCHES



ARMSTRONG
INDUSTRIAL HAND TOOLS

| Model No. | Mfg. No. | Point Dia." | Stock Size" | Length" | Wt. lbs. | Price /Each |
|-----------|----------|-------------|-------------|---------|----------|-------------|
| U0400 | 70-221 | 5/16 | 3/4 | 18 | 0.82 | 32.80 |

Can't find what you're looking for?

Call us today!

HAMMERS, PRY BARS & PUNCHES

PRICK PUNCHES

- Points are carefully ground to the correct taper
- Sharper than the normal centre punch
- Allows for exact placement of point, providing sharp impressions
- Properly hardened and tempered



Starrett®

| Model No. | Mfg. No. | Diameter at Top of Length" | Tapered Point" | Price /Each |
|-----------|----------|--|----------------|-------------|
| HW098 | 53043 | 4 | 5/64 | 11.50 |
| HW099 | 53044 | 4 | 1/8 | 11.50 |
| HW100 | 53046 | 4 | 5/32 | 15.50 |
| HW101 | 57078 | Combination Starrett® punch set in plastic case. One each HW098, HW099 and HW100 prick punches, and one each TB413 and TBB414 center punches | | 44.20 |

STARTING PUNCHES



ARMSTRONG
INDUSTRIAL HAND TOOLS

| Model No. | Mfg. No. | Point Dia." | Stock Size" | Length" | Wt. lbs. | Price /Each |
|-----------|----------|-------------|-------------|---------|----------|-------------|
| U0384 | 70-153 | 1/16 | 5/16 | 4 1/2 | 0.08 | 8.66 |
| U0385 | 70-155 | 3/32 | 5/16 | 4 1/2 | 0.09 | 8.48 |
| U0386 | 70-157 | 1/8 | 5/16 | 4 1/2 | 0.09 | 9.84 |
| U0387 | 70-159 | 5/32 | 3/8 | 5 | 0.13 | 9.95 |
| U0388 | 70-161 | 3/16 | 3/8 | 5 | 0.13 | 9.95 |
| U0390 | 70-165 | 1/4 | 1/2 | 6 | 0.29 | 10.80 |
| U0391 | 70-167 | 5/16 | 5/8 | 7 | 0.32 | 10.50 |

AUTOMATIC CENTRE PUNCHES WITH ADJUSTABLE STROKE

All working parts are made of properly hardened tool steel. The hardened tool steel point may easily be removed for resharpening or replacement. (Replacement Point No. **PT22256**) Works on metal, plastics, wood and other machinable materials.



Starrett®

| Model No. | EDP No. | Length Inch | Length mm | Diameter Inch | Diameter mm | Price /Each |
|-----------|---------|-------------|-----------|---------------|-------------|-------------|
| HW102 | 53048 | 5 | 125 | 5/8 | 16 | 48.00 |

LIGHTWEIGHT AUTOMATIC CENTRE PUNCHES

- One-hand spring impact operation, no hammer needed
- Lightweight aluminum body with long wearing alloy steel parts
- Spring tension adjusts for light or heavy markings
- Hardened steel point
- Pencil slim design with pocket clip



GENERAL®

| Model No. | Mfg. No. | Price /Each |
|-----------|----------|-------------|
| TV173 | 87 | 29.95 |

PUNCH & CHISEL SETS

- Punch and chisel sets are an excellent way to keep your tools organized
- These sets are packed in heavy-duty vinyl rolls for easy access, organization and storage

8-PC. PUNCH & CHISEL SET:

Model No. TLZ433
Price/Each \$60.25



aurora tools®

Set includes:

| Model No. | Style | Size" | Price /Each |
|-----------|--------------|-------|-------------|
| TLZ398 | Cold Chisel | 1/2 | 8.55 |
| TLZ399 | Cold Chisel | 5/8 | 9.30 |
| TLZ400 | Cold Chisel | 3/4 | 15.35 |
| TLZ417 | Centre Punch | 5/32 | 5.70 |
| TLZ403 | Pin Punch | 1/8 | 5.80 |
| TLZ405 | Pin Punch | 3/16 | 5.80 |
| TLZ406 | Pin Punch | 1/4 | 6.55 |
| TLZ410 | Drift Punch | 3/16 | 11.25 |

14-PC. PUNCH & CHISEL SET:

Model No. TLZ434
Price/Each \$98.95

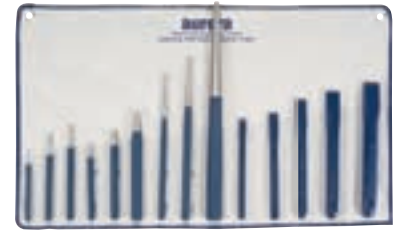

aurora tools®

Set includes:

| Model No. | Style | Size" | Price /Each |
|-----------|--------------|-------|-------------|
| TLZ397 | Cold Chisel | 3/8 | 8.55 |
| TLZ398 | Cold Chisel | 1/2 | 8.55 |
| TLZ399 | Cold Chisel | 5/8 | 9.30 |
| TLZ400 | Cold Chisel | 3/4 | 15.35 |
| TLZ556 | Cold Chisel | 7/8 | 18.65 |
| TLZ416 | Centre Punch | 1/8 | 5.70 |
| TLZ417 | Centre Punch | 5/32 | 5.70 |
| TLZ418 | Centre Punch | 1/4 | 7.30 |
| TLZ401 | Pin Punch | 1/16 | 4.70 |
| TLZ403 | Pin Punch | 1/8 | 5.80 |
| TLZ405 | Pin Punch | 3/16 | 5.80 |
| TLZ408 | Drift Punch | 1/8 | 8.00 |
| TLZ409 | Drift Punch | 5/32 | 8.90 |
| TLZ413 | Drift Punch | 5/16 | 17.20 |

See page 1308 for
Hand Held Deburring Tools



EXTENSION GASKET CUTTERS

- Hefty brass cutting head slides easily over a variety of gasket materials
- Modular extension design allows you to quickly adjust your cutting size
- Special cutting blades are held securely, ensuring consistent and repetitive cuts in material up to 3/4" thick
- Choose from 10 convenient kits to accommodate your cutting requirements

ALLPAX®

GASKET CUTTER KITS (METRIC)

- NO. 1**
- Cuts 6 mm to 330 mm in diameter
- PARTS INCLUDED:**
- | | |
|------------------------------|----------------------------------|
| Cutter block & head assembly | 19 mm long centre pin |
| Cutter head screws (2) | 457 mm cutting board |
| Gasket cutter blades (6) | Cutting knob for small diameters |
| Pivot post | Post with offset pin |
| Knurled nuts (2) | Piercing tool |
| Fibre washers (2) | Hex key |
| 13 mm short centre pin | |
- Weight: 10.4 lbs.
Model No. TLZ377 Mfg. No. 100KM330
Price/Each \$410.00
- NO. 2**
- Cuts 6 mm to 635 mm in diameter
- PARTS INCLUDED:**
- | | |
|-------------------------------|----------------------------------|
| Cutter block & head assembly | 19 mm long centre pin |
| Cutter head screws (2) | Extension bar 330 mm to 635 mm |
| Gasket cutter blades (6) | 457 mm cutting board |
| Pivot post | Cutting knob for small diameters |
| Pivot post for extension bars | Post with offset pin |
| Knurled nuts (3) | Piercing tool |
| Fibre washers (3) | Hex key |
| 13 mm short centre pin | |
- Weight: 10.5 lbs.
Model No. TLZ378 Mfg. No. 100KM635
Price/Each \$436.00
- NO. 3**
- Cuts 6 mm to 940 mm in diameter
- PARTS INCLUDED:**
- | | |
|--------------------------------|----------------------------------|
| Cutter block & head assembly | 19 mm long centre pin |
| Cutter head screws (2) | Extension bar 330 mm to 635 mm |
| Gasket cutter blades (6) | Extension bar over 635 mm |
| Pivot post | 457 mm cutting board |
| Pivot post for extension bars | Cutting knob for small diameters |
| Knurled nuts (3) | Post with offset pin |
| Knurled nuts for extension bar | Piercing tool |
| Fibre washers (3) | Hex key |
| 13 mm short centre pin | |
- Weight: 10.8 lbs.
Model No. TLZ379 Mfg. No. 100KM940
Price/Each \$456.00
- NO. 4**
- Cuts 6 mm to 1245 mm in diameter
- PARTS INCLUDED:**
- | | |
|-------------------------------------|----------------------------------|
| Cutter block & head assembly | 19 mm long centre pin |
| Cutter head screws (2) | Extension bar 330 mm to 635 mm |
| Gasket cutter blades (6) | Extension bar over 635 mm (2) |
| Pivot post | 457 mm cutting board |
| Pivot post for extension bars | Cutting knob for small diameters |
| Knurled nuts (3) | Post with offset pin |
| Knurled nuts for extension bars (2) | Piercing tool |
| Fibre washers (3) | Hex key |
| 13 mm short centre pin | |
- Weight: 11.8 lbs.
Model No. TLZ375 Mfg. No. 100KM1245
Price/Each \$483.00
- NO. 5**
- Cuts 6 mm to 1550 mm in diameter
- PARTS INCLUDED:**
- | | |
|-------------------------------------|----------------------------------|
| Cutter block & head assembly | 19 mm long centre pin |
| Cutter head screws (2) | Extension bar 330 mm to 635 mm |
| Gasket cutter blades (6) | Extension bar over 635 mm (3) |
| Pivot post | 457 mm cutting board |
| Pivot post for extension bars | Cutting knob for small diameters |
| Knurled nuts (3) | Post with offset pin |
| Knurled nuts for extension bars (3) | Piercing tool |
| Fibre washers (3) | Hex key |
| 13 mm short centre pin | |
- Weight: 11.8 lbs.
Model No. TLZ376 Mfg. No. 100KM1550
Price/Each \$503.00



GASKET CUTTER KITS (IMPERIAL)

- NO. 1**
- Cuts 1/4" I.D. to 13" in diameter
- PARTS INCLUDED:**
- | | |
|------------------------------|----------------------------------|
| Cutter block & head assembly | 3/4" long centre pin |
| Cutter head screws (2) | 18" cutting board |
| Gasket cutter blades (6) | Cutting knob for small diameters |
| Pivot post | Post with offset pin |
| Knurled nuts (2) | Piercing tool |
| Fibre washers (2) | Hex key |
| 1/2" short centre pin | |
- Weight: 10.4 lbs.
Model No. TLZ370 Mfg. No. 100K13
Price/Each \$410.00
- NO. 2**
- Cuts 1/4" to 25" in diameter
- PARTS INCLUDED:**
- | | |
|-------------------------------|----------------------------------|
| Cutter block & head assembly | 3/4" long centre pin |
| Cutter head screws (2) | Extension bar 13" to 25" |
| Gasket cutter blades (6) | 18" cutting board |
| Pivot post | Cutting knob for small diameters |
| Pivot post for extension bars | Post with offset pin |
| Knurled nuts (3) | Piercing tool |
| Fibre washers (3) | Hex key |
| 1/2" short centre pin | |
- Weight: 10.5 lbs.
Model No. TLZ371 Mfg. No. 100K25
Price/Each \$436.00
- NO. 3**
- Cuts 1/4" to 37" in diameter
- PARTS INCLUDED:**
- | | |
|--------------------------------|----------------------------------|
| Cutter block & head assembly | 3/4" long centre pin |
| Cutter head screws (2) | Extension bar 13" to 25" |
| Gasket cutter blades (6) | Extension bar over 25" |
| Pivot post | 18" cutting board |
| Pivot post for extension bars | Cutting knob for small diameters |
| Knurled nuts (3) | Post with offset pin |
| Knurled nuts for extension bar | Piercing tool |
| Fibre washers (3) | Hex key |
| 1/2" short centre pin | |
- Weight: 10.8 lbs.
Model No. TLZ372 Mfg. No. 100K37
Price/Each \$456.00
- NO. 4**
- Cuts 1/4" to 49" in diameter
- PARTS INCLUDED:**
- | | |
|-------------------------------------|----------------------------------|
| Cutter block & head assembly | 3/4" long centre pin |
| Cutter head screws (2) | Extension bar 13" to 25" |
| Gasket cutter blades (6) | Extension bar over 25" (2) |
| Pivot post | 18" cutting board |
| Pivot post for extension bars | Cutting knob for small diameters |
| Knurled nuts (3) | Post with offset pin |
| Knurled nuts for extension bars (2) | Piercing tool |
| Fibre washers (3) | Hex key |
| 1/2" short centre pin | |
- Weight: 11.8 lbs.
Model No. TLZ373 Mfg. No. 100K49
Price/Each \$483.00
- NO. 5**
- Cuts 1/4" to 61" in diameter
- PARTS INCLUDED:**
- | | |
|-------------------------------------|----------------------------------|
| Cutter block & head assembly | 3/4" long centre pin |
| Cutter head screws (2) | Extension bar 13" to 25" |
| Gasket cutter blades (6) | Extension bar over 25" (3) |
| Pivot post | 18" cutting board |
| Pivot post for extension bars | Cutting knob for small diameters |
| Knurled nuts (3) | Post with offset pin |
| Knurled nuts for extension bars (3) | Piercing tool |
| Fibre washers (3) | Hex key |
| 1/2" short centre pin | |
- Weight: 11.8 lbs.
Model No. TLZ374 Mfg. No. 100K61
Price/Each \$499.00

See pages 1356 - 1359 for
Scissors and Snips

PLUMBING TOOLS



STRAP WRENCHES

- Best for any polished pipe
- Strong, woven nylon strap gives tight grip
- Polyurethane-coated strap
- Replaceable straps available

TR023



RIDGID

| Model No. | Cat. No. | Mfg. No. | Handle Length | | Strap Length | | Strap Width | | Pipe Capacity | | Tube Capacity (O.D.) | | Weight | | Price /Each |
|-----------|----------|----------|---------------|-----|--------------|------|-------------|----|---------------|-----|----------------------|-----|--------|-----|-------------|
| | | | in. | mm | in. | mm | in. | mm | in. | mm | in. | mm | lbs. | kg | |
| TR023 | 31335 | 1 | 11 3/4 | 300 | 17 | 425 | 1/2 | 12 | 2 | 50 | 3 1/2 | 90 | 1 1/4 | 0.5 | 47.50 |
| TR163 | 31340 | 2 | 11 3/4 | 300 | 17 | 425 | 1 1/8 | 30 | 2 | 50 | 3 1/2 | 90 | 1 3/4 | 0.8 | 52.10 |
| TR026 | 31355 | 2P* | 11 3/4 | 300 | 17 | 425 | 1 1/16 | 27 | 2 | 50 | 3 1/2 | 90 | 1 3/4 | 0.8 | 59.50 |
| TR025 | 31350 | 2 | 11 3/4 | 300 | 24 | 600 | 1 1/8 | 30 | 2 | 50 | 5 1/2 | 135 | 1 3/4 | 0.8 | 62.50 |
| TR027 | 31360 | 5 | 18 | 450 | 29 1/4 | 750 | 1 3/4 | 45 | 5 | 125 | 7 | 175 | 2 | 0.9 | 99.90 |
| TR029 | 31370 | 5P* | 18 | 450 | 29 1/4 | 750 | 1 3/4 | 45 | 5 | 125 | 5 1/2 | 135 | 2 1/8 | 1.0 | 109.00 |
| TR024 | 31345 | 2 | 11 3/4 | 300 | 30 | 760 | 1 1/8 | 30 | 2 | 50 | 5 1/2 | 135 | 1 3/4 | 0.8 | 59.90 |
| TR028 | 31365 | 5 | 18 | 450 | 48 | 1200 | 1 3/4 | 45 | 5 | 125 | 12 | 300 | 2 | 0.9 | 122.00 |

* Strap designed for use with plastic pipe.

HEX WRENCHES

- Provides multi-sided, secure grip on all hex nuts, square nuts, unions, and valve packing nuts
- Extra-wide opening offset model is ideal for securing drain nuts on sinks and tubs

TDX443



RIDGID

| Model No. | Cat. No. | Mfg. No. | Length | | Capacity | | Weight | | Price /Each |
|-----------|----------|----------|--------|-----|-------------|-------|--------|-----|-------------|
| | | | in. | mm | in. | mm | lbs. | kg | |
| THX679 | 31305* | E-110 | 9 1/2 | 240 | 1 1/8-2 5/8 | 29-67 | 1 1/2 | 0.6 | 49.90 |
| TDX443 | 31275 | 17 | 14 1/2 | 362 | 5/8-1 1/4 | 16-30 | 4 1/2 | 2.0 | 89.50 |
| TDX444 | 31280 | 25 | 20 | 500 | 1-2 | 25-50 | 8 3/4 | 4.0 | 139.00 |

* Offset Hex

SPUD WRENCHES

- Narrow jaws to fit into tight places
- Smooth, toothless jaws ideal for square or rectangular stock

TR030



RIDGID

| Model No. | Cat. No. | Mfg. No. | Length | | Capacity | | Weight | | Price /Each |
|-----------|----------|----------|--------|-----|-----------|-------|--------|-----|-------------|
| | | | in. | mm | in. | mm | lbs. | kg | |
| TR030 | 31400 | - | 12 | 300 | 3/8-2 5/8 | 10-67 | 2 1/2 | 1.1 | 59.90 |

CHAIN TONGS

- Provide extra leverage for the toughest jobs
- Double-end jaw styles which can be reversed, (except model TTX127 which is a single-end tong)
- All chains are tested to 2/3 of their breaking strength

TTX129



RIDGID

| Model No. | Cat. No. | Mfg. No. | Total Length | | Pipe Capacity | | Chain Length | | Breaking Strain* | | Weight | | Price /Each |
|-----------|----------|----------|--------------|------|---------------|---------|--------------|------|------------------|--------|--------|----|-------------|
| | | | in. | mm | in. | mm | in. | mm | lbs. | kg | lbs. | kg | |
| TTX129 | 92665 | 3229 | 27 | 686 | 1/4-2 1/2 | 13-73 | 17 1/2 | 445 | 13 800 | 6260 | 11 | 5 | 397.00 |
| TTX131 | 92670 | 3231 | 37 | 939 | 3/4-4 | 26-114 | 22 1/2 | 572 | 17 600 | 7983 | 21 | 10 | 496.00 |
| TTX133 | 92675 | 3233 | 44 | 1117 | 1-6 | 33-168 | 32 | 813 | 20 100 | 9117 | 29 | 13 | 637.00 |
| TTX135 | 92680 | 3235 | 50 | 1270 | 1 1/2-8 | 48-219 | 40 1/2 | 1029 | 22 000 | 9979 | 39 | 18 | 779.00 |
| TTX137 | 92685 | 3237 | 64 | 1625 | 2-12 | 60-323 | 55 1/2 | 1410 | 31 000 | 14 061 | 67 | 30 | 1278.00 |
| TTX127 | 92660 | 3215 | 87 | 2209 | 4-18 | 114-457 | 74 1/2 | 1892 | 56 000 | 25 401 | 156 | 71 | 3180.00 |

Note: Chain breaking strain: All chains are tested to 2/3 of their breaking strength.

CHAIN WRENCHES

- Double jaw gives fast, ratchet-like action in either direction
- Replaceable alloy steel jaws
- One-piece forged alloy steel handle and jaw
- Ideal for use in close quarters

TR019



RIDGID

| Model No. | Cat. No. | Mfg. No. | Rated Pipe Cap. in. | Actual O.D. Cap mm | Chain Length | | Weight | | Price /Each | | |
|-----------|----------|----------|---------------------|--------------------|--------------|-----|--------|-----|-------------|-----|--------|
| | | | | | in. | mm | lbs. | kg | | | |
| TR019 | 31310 | C-12 | 2 | 50 | 4 | 100 | 15 3/4 | 390 | 1 3/4 | 0.8 | 78.20 |
| TR162 | 31315 | C-14 | 2 | 50 | 5 | 125 | 18 1/2 | 460 | 2 3/4 | 1.2 | 94.90 |
| TR020 | 31320 | C-18 | 2 1/2 | 60 | 5 | 125 | 20 1/4 | 500 | 6 | 2.7 | 149.00 |
| TR021 | 31325 | C-24 | 3 | 75 | 5 | 125 | 20 1/4 | 500 | 8 1/4 | 3.7 | 173.00 |
| TR022 | 31330 | C-36 | 4 1/2 | 110 | 7 1/2 | 185 | 29 | 725 | 15 3/4 | 7.1 | 349.00 |

COMPOUND LEVERAGE WRENCHES

- Unique design multiplies the turning force applied to a pipe
- Ideal for freeing locked couplings and joints frozen by age or damage

THX681



RIDGID

| Model No. | Cat. No. | Mfg. No. | Nom. Size | | Pipe Capacity | | Weight | | Price /Each |
|-----------|----------|----------|-----------|----|---------------|-----|--------|------|-------------|
| | | | in. | mm | in. | mm | lbs. | kg | |
| THX681 | 31375 | S-2 | - | - | 2 | 50 | 7 1/4 | 3.3 | 517.00 |
| THX682 | 31380 | S-4A | - | - | 5 | 125 | 33 1/2 | 15.2 | 754.00 |
| THX683 | 31385 | S-6A | - | - | 6 | 150 | 45 1/2 | 20.6 | 1021.00 |
| THX684 | 31390 | S-8A | - | - | 8 | 200 | 68 1/2 | 31.1 | 1519.00 |

STRAIGHT PIPE WRENCHES

- Sturdy, cast iron housing and I-beam handle with full-floating forged hook jaw
- Nonstick adjustment nut, replaceable hook and heel jaws



TV792

RIDGID

| Model No. | Cat. No. | Mfg. No. | Nom. Size in. mm | Pipe Capacity in. mm | Weight lbs. kg | Price /Each |
|-----------|----------|----------|------------------|----------------------|----------------|-------------|
| TV792 | 31000 | 6 | 6 150 | 3/4 20 | 1/2 0.2 | 22.90 |
| TV793 | 31005 | 8 | 8 200 | 1 25 | 3/4 0.3 | 26.90 |
| TV794 | 31010 | 10 | 10 250 | 1 1/2 40 | 1 3/4 0.8 | 35.90 |
| TV795 | 31015 | 12 | 12 300 | 2 50 | 2 3/4 1.2 | 39.90 |
| TV796 | 31020 | 14 | 14 350 | 2 50 | 3 1/2 1.6 | 45.90 |
| TV797 | 31025 | 18 | 18 450 | 2 1/2 65 | 5 3/4 2.6 | 65.50 |
| TV798 | 31030 | 24 | 24 600 | 3 80 | 9 3/4 4.4 | 99.90 |
| TV799 | 31035 | 36 | 36 900 | 5 125 | 19 8.7 | 229.00 |
| TR181 | 31040 | 48 | 48 1200 | 6 150 | 34 1/4 15.6 | 359.00 |
| TR182 | 31045 | 60 | 60 1500 | 8 200 | 51 1/4 23.3 | 508.00 |

RAPIDGRIP™

- Quick one-handed operation
- Spring-loaded jaw design provides rapid ratcheting action



TCX021

RIDGID

| Model No. | Cat. No. | Mfg. No. | Nom. Size in. mm | Pipe Capacity in. mm | Fittings Cap. in. mm | Weight lbs. kg | Price /Each |
|-----------|----------|----------|------------------|----------------------|----------------------|----------------|-------------|
| TCX021 | 10348 | 10 | 10 250 | 1 1/2 37.5 | 1 25 | 1.6 0.7 | 43.60 |
| TCX023 | 10358 | 14 | 14 350 | 2 50 | 1 1/2 37.5 | 3.1 1.4 | 53.50 |

RIDGID® WRENCH PARTS

| Wrench Size Str. | End | Pipe Cap.¹ | Handle Assembly | | Nut Model No. | Pin Model No. | Heel Jaw & Pin Assembly Model No. | Coil & Flat Spring Assembly Model No. | Hook Jaw Model No. | |
|------------------|-----------|------------|-------------------------|--------------------|---------------|---------------|-----------------------------------|---------------------------------------|--------------------|-----------------------------|
| | | | Straight Iron Model No. | End Iron Model No. | | | | | | Straight Aluminum Model No. |
| 6 | E-6 | 3/4 | THX688 | THX699 | - | THX719 | THX721 | THX717 | THX718 | THX716 |
| 8 | E-8 | 1 | THX689 | THX700 | - | THX725 | THX727 | THX723 | THX724 | THX722 |
| 10 | E-10 | 1 1/2 | THX690 | THX701 | THX710 | THX733 | THX736 | THX731 | THX735 | THX729 |
| 12 | E-12 | 2 | THX691 | THX702 | TMX159 | THX740 | THX741 | THX738 | THX739 | THX737 |
| 14 | E-14 | 2 | THX692 | THX704 | THX711 | THX744 | THX741 | THX738 | THX743 | THX742 |
| 18 | E-18 | 2 1/2 | THX694 | THX706 | THX712 | THX748 | THX749 | THX746 | THX747 | THX745 |
| 24 | E-24 | 3 | THX695 | THX707 | THX713 | THX753 | THX754 | THX751 | THX752 | THX750 |
| 36 | E-36 | 5 | THX696 | THX709 | THX714 | THX758 | THX759 | THX756 | THX757 | THX755 |
| 48 | - | 6 | THX697 | - | THX715 | THX763 | THX764 | THX761 | THX762 | THX760 |
| 60 | - | 8 | THX698 | - | - | THX768 | THX770 | THX766 | THX767 | THX765 |
| 10 | Rapwrench | 1 1/2 | THX953 | - | - | THX733 | THX736 | THX731 | THX735 | THX729 |

Call our order desk for pricing

HEAVY-DUTY OFFSET PIPE WRENCHES

- Jaw opening parallel to the handle
- Narrow hook jaw head provides easy entry into tight spots



TR159

| Model No. | Cat. No. | Mfg. No. | Nom. Size in. mm | Pipe Capacity in. mm | Weight lbs. kg | Price /Each |
|-----------|----------|----------|------------------|----------------------|----------------|-------------|
| TR159 | 89435 | 14 | 14 350 | 2 50 | 2 1/4 1.0 | 82.50 |
| TR160 | 89440 | 18 | 18 450 | 2 1/2 65 | 5 3/4 2.6 | 119.00 |
| TR161 | 89445 | 24 | 24 600 | 3 80 | 9 3/4 4.4 | 190.00 |

See pages 1293 - 1294 for Bench Mount Vises



END PIPE WRENCHES

- Fast and easy grip for pipe working in restricted spaces or close to a wall



TR001

RIDGID

| Model No. | Cat. No. | Mfg. No. | Nom. Size in. mm | Pipe Capacity in. mm | Weight lbs. kg | Price /Each |
|-----------|----------|----------|------------------|----------------------|----------------|-------------|
| TR001 | 31050 | E-6 | 6 150 | 3/4 20 | 1/2 0.2 | 28.50 |
| TR002 | 31055 | E-8 | 8 200 | 1 25 | 3/4 0.3 | 32.60 |
| TR003 | 31060 | E-10 | 10 250 | 1 1/2 40 | 1 3/4 0.8 | 43.50 |
| TR004 | 31065 | E-12 | 12 300 | 2 50 | 2 3/4 1.3 | 50.50 |
| TR005 | 31070 | E-14 | 14 350 | 2 50 | 3 1/2 1.6 | 57.70 |
| TR006 | 31075 | E-18 | 18 450 | 2 1/2 65 | 5 3/4 2.6 | 83.70 |
| TR007 | 31080 | E-24 | 24 600 | 3 80 | 9 3/4 4.4 | 131.00 |
| TR008 | 31085 | E-36 | 36 900 | 5 125 | 19 8.7 | 284.00 |

PIPE WRENCHES

- Drop-forged alloy steel jaw
- Durable ductile steel body provides the ultimate in performance
- Precision milled sure gripping teeth
- Spring action ensures sure grip and quick release



aurora tools™ TJZ106

| Model No. | Length" | Pipe Capacity" | Price/Each |
|-----------|---------|----------------|------------|
| TJZ106 | 8 | 1 | 11.55 |
| TJZ107 | 10 | 1 1/2 | 15.25 |
| TJZ108 | 12 | 2 | 18.85 |
| TJZ109 | 14 | 2 | 23.25 |
| TJZ110 | 18 | 2 1/2 | 28.35 |

ALUMINUM HANDLE STRAIGHT PIPE WRENCHES

- Nearly 40% lighter than comparable cast iron models of the same size
- Jaws and all other parts identical to Ridgid® heavy-duty wrenches
- Also available with special hook and heel jaws for plastic-coated pipe



TR009

RIDGID

| Model No. | Cat. No. | Mfg. No. | Nom. Size in. mm | Pipe Capacity in. mm | Weight lbs. kg | Price /Each |
|-----------|----------|----------|------------------|----------------------|----------------|-------------|
| TR009 | 31090 | 810 | 10 250 | 1 1/2 40 | 1 0.4 | 54.90 |
| TR010 | 47057 | 812 | 12 300 | 2 50 | 2 1/2 1.1 | 65.50 |
| TR011 | 31095 | 814 | 14 350 | 2 50 | 2 1/2 1.1 | 69.90 |
| TR012 | 31100 | 818 | 18 450 | 2 1/2 65 | 3 3/4 1.7 | 89.90 |
| TR013 | 31105 | 824 | 24 600 | 3 80 | 6 2.7 | 145.00 |
| TR014 | 31110 | 836 | 36 900 | 5 125 | 11 5.0 | 259.00 |
| TR015 | 31115 | 848 | 48 1200 | 6 150 | 18 1/2 8.4 | 510.00 |

PLUMBING TOOLS

ENCLOSED SCREW TUBING CUTTERS

- Enclosed feed screw to eliminate clogging and jamming
- Grooved rolls for close-to-flare cuts, and a fold-away reamer
- Made from high-strength zinc alloy with a spare cutter wheel in the handle
- Cuts copper, brass, and aluminum tubing, and thin-wall conduit
- Model **TR169** and **TR045** have all the features of model **TR168** and **TR044**, plus a quick-acting mechanism



TR168

RIDGID

| Model No. | Cat. No. | Mfg. No. | Description | Std. Wheel | Capacity | | Weight | | Price /Each |
|-----------|----------|----------|------------------------------|------------|-----------|------|--------|------|-------------|
| | | | | | in. | mm | lbs. | kg | |
| TR168 | 31622 | 150 | Enclosed Feed Cutter | E-3469 | 1/8-1 1/8 | 3-28 | 1 | 0.45 | 42.90 |
| TR044 | 31627 | 150 | Above w/H-D Wheel(s) | E-4546 | 1/8-1 1/8 | 3-28 | 1 | 0.45 | 45.50 |
| TR169 | 33055 | 205 | Ratcheting Encl. Feed Cutter | E-3469 | 1/4-2 3/8 | 6-60 | 2 | 0.91 | 119.00 |
| TR045 | 33070 | 205 | Above w/H-D Wheel(s) | E-4546 | 1/4-2 3/8 | 6-60 | 2 | 0.91 | 115.00 |
| TQX037 | 66737 | 150-L | Enclosed Feed Cutter | E-3469 | 1/4-1 3/8 | 3-35 | 1 | 0.45 | 43.50 |
| TQX038 | 66742 | 150-LS | Above w/H-D Wheel(s) | E-4546 | 1/4-1 3/8 | 3-35 | 1 1/8 | 0.51 | 46.50 |

STANDARD TUBING CUTTERS

NOS. 10, 15, 20, 30, & 15-SI

- Clean, square cuts are easily made on copper, brass, aluminum, and thin-wall conduit
- Models **TR046** – **TR051** feature a convenient fold-away reamer
- **TR052** and **TR053** are rated for larger diameter steel and stainless steel tubing
- **TTX876** is especially designed for stainless steel tubing



TR048

RIDGID

| Model No. | Cat. No. | Mfg. No. | Description | Std. Wheel | Capacity | | Weight | | Price /Each |
|-----------|----------|----------|------------------------|------------|------------|-------|--------|------|-------------|
| | | | | | in. | mm | lbs. | kg | |
| TR046 | 32910 | 10 | Screw Feed Cutter* | F-158 | 1/8-1 | 3-25 | 7/8 | 0.40 | 43.50 |
| TR047 | 32915 | 10 | Above w/H-D Wheel* | E-1240 | 1/8-1 | 3-25 | 7/8 | 0.40 | 43.90 |
| TR048 | 32920 | 15 | Screw Feed Cutter* | F-158 | 3/16-1 1/8 | 5-28 | 1 1/2 | 0.68 | 49.90 |
| TR049 | 32925 | 15 | Above w/H-D Wheel* | E-1240 | 3/16-1 1/8 | 5-28 | 1 1/2 | 0.68 | 51.90 |
| TR050 | 32930 | 20 | Screw Feed Cutter* | F-158 | 5/8-2 1/8 | 16-54 | 1 3/4 | 0.80 | 98.50 |
| TR051 | 32935 | 20 | Above w/H-D Wheel* | E-1240 | 5/8-2 1/8 | 16-54 | 1 3/4 | 0.80 | 99.50 |
| TR052 | 32940 | 30 | Screw Feed Cutter | E-2558 | 1-3 1/8 | 25-79 | 3 1/2 | 1.60 | 152.00 |
| TR053 | 32950 | 30 | Above w/H-D Wheel | E-2191 | 1-3 1/8 | 25-79 | 3 1/2 | 1.60 | 147.00 |
| TTX876 | 97212 | 15-SI | Stainless Steel Cutter | E-1525 | 3/16-1 1/8 | 5-28 | 1 1/2 | 0.68 | 74.90 |

* Now available with spare cutter wheel and extra large knob for easier tightening of feed screw.

PLASTIC PIPE & TUBING CUTTERS

- Designed for quick, clean cuts through plastic pipe and tube
- Cutters are easy-to-use, can cut most types of plastic and rubber pipe or tubing
- One-hand operation
- Replaceable stainless steel cutting blade folds into handle for safe handling and carrying
- Ratcheting models are constructed of durable aluminum

RIDGID



TLZ276

TLZ268

TLZ428

| Model No. | Cat. No. | Mfg. No. | Description | Repl. Blade | Capacity (OD) | | Weight | | Price /Each |
|-----------|----------|----------|-----------------------|-------------|---------------|----|--------|------|-------------|
| | | | | | in. | mm | lbs. | kg | |
| TLZ428 | 23493 | PC-1375 | Single Stroke Cutter | TLZ429 | 1 3/8 | 35 | 0.70 | 0.32 | 49.90 |
| TLZ276 | 23488 | PC-1250 | Scissor-Style Cutter | TLZ277 | 1 5/8 | 42 | 0.45 | 0.20 | 23.90 |
| TLZ268 | 23498 | RC-1625 | Ratchet Action Cutter | TLZ432 | 1 5/8 | 42 | 1.15 | 0.52 | 89.90 |
| TLZ430 | 30088 | RC-2375 | Ratchet Action Cutter | TLZ431 | 2 3/8 | 63 | 1.88 | 0.85 | 159.00 |

FLARING TOOLS

- Provides smooth, uniform flares with minimum effort
- New ratcheting feed screw handle (QH722) turns easily and requires less motion and effort than a standard handle
- Hardened steel flaring cone, eccentrically mounted in needle bearings, produces rolling action for even metal flow, giving uniform flare walls without galling
- Recommended for soft materials such as aluminum and soft copper
- **TKX570**, **TKX571** and **TKX569** will also flare steel, stainless steel, hard copper and brass
- **QH722**, **TMX214** and **QH723** will flare steel, stainless steel, hard copper, and brass through wall thickness of 0.035"



QH722

RIDGID

| Model No. | Cat. No. | Mfg. No. | Type | Sizes* | Weight | | Price /Each |
|---------------------|----------|----------|----------------------------|--|-----------------|-----|-------------|
| | | | | | lbs. | kg | |
| QH722* | 83037 | 458R | 45° SAE Flares | 1/8, 3/16, 1/4, 5/16, 3/8, 1/2, 5/8, 3/4 | 3 1/2 | 1.6 | 210.00 |
| TKX570 | 41295 | 454-W | 45° SAE-Nominal Water Tube | 3/8, 1/2, 3/4, 1 | 6 1/4 | 2.8 | 468.00 |
| TKX571 | 41300 | 455 | 45° SAE Flares | 1/2, 5/8, 3/4, 7/8, 1 | 6 3/4 | 3.1 | 468.00 |
| QH723 | 41162 | 377 | 37° SAE Flares | 3/16, 1/4, 5/16, 3/8, 1/2, 5/8, 3/4 | 3 1/2 | 1.6 | 186.00 |
| TKX569 | 41285 | 375 | 37° SAE Flares | 1/2, 5/8, 3/4, 7/8, 1 | 6 3/4 | 3.1 | 459.00 |
| METRIC MODEL | | | | | Sizes mm | | |
| TMX214 | 50257 | 458MM | 45° SAE Flares | 4, 4.75, 6, 8, 10, 12, 15, 16 | 3 1/2 | 1.6 | 199.00 |

*Model with ratchet feature

POWER SPIN™ & KWIK-SPIN® HAND SPINNERS

- Light-duty product for drains to 11.2" (38 mm)
- Comfortable hand grip eases effort
- 1.4" x 25' hollow core cable held securely by a steel collar and thumb screw
- Power Spin™ automatically advances and retrieves cable
- Power Spin™ operates by hand or by adding any variable speed drill

RIDGID

| Model No. | Cat. No. | Description | Width and Length | | | | Weight | | Price /Each | | |
|-----------|----------|--|------------------|---|-----|-----|--------|-----|-------------|------|-------|
| | | | in. | x | ft. | mm | x | m | | lbs. | kg |
| TSX514 | 88387 | Power-Spin™ Drill/Hand Driven Spinner | 1/4 | x | 25 | 6.3 | x | 7.6 | 4.5 | 2.0 | 72.50 |
| TCX526 | 15733 | Kwik-Spin® Hand Spinner | 1/4 | x | 25 | 6.3 | x | 7.6 | 5 | 2.3 | 39.90 |
| TCX349 | 14013 | Kwik-Spin®/Power Spin™ Replacement Cable | 1/4 | x | 25 | 6.3 | x | 7.6 | 1 | 0.5 | 17.90 |



TSX514

K-5 GRAPPLER HOOKS

- Retrieves rocks, tools, objects
- Extends your reach 6' to deepest traps

RIDGID

| Model No. | Cat. No. | Mfg. No. | Description | Weight | | Price /Each |
|-----------|----------|----------|---------------|--------|-----|-------------|
| | | | | lbs. | kg | |
| TNX413 | 59190 | K-5 | Grappler Hook | 5 | 2.3 | 335.00 |



TNX413

K-45 ELECTRIC DRAIN CLEANERS

- Excellent for small line cleaning. Opens clogged lavatory, sink lines, urinals, and tub/shower drains
 - 5/16" cables best for 3/4" to 1 1/2" lines
 - 3/8" cables best for 1 1/4" to 2 1/2" lines
- Lightweight, easy-to-use, no set-up required
- Variable speed 1/2" ball bearing power unit rotates cable 0-600 RPM
- Two-piece twist lock canister with interchangeable inner drum
 - Makes cable changeout simple; easy to match the right cable to the job
 - New inner drum prevents water leaks and greatly reduces cable flip-over
 - Drums won't rust or dent – ever
- Drum capacity: 50' of 5/16" (15 m/8 mm) or 35' of 3/8" (11 m/10 mm)
- Slide action chuck
- CSA approved, 115 V
- Approved to UL standards (NRTLCL)



TQX212

RIDGID

| Model No. | Cat. No. | Mfg. No. | Description | Weight | | Price /Each |
|-----------|----------|----------|--|--------|------|-------------|
| | | | | lbs. | kg | |
| TQX212 | 36013 | K-45-1 | K-45 Drain Cleaner with C-11C Cable w/Bulb Auger (5/16" x 25") and C-6429 Carrying Case | 26 | 11.8 | 579.00 |
| TQX213 | 36023 | K-45-5 | Same as TQX212 plus: C-6 Cable w/5/8" Coupling (3/8" x 35"), A-13 Pin Key, T-203 Bulb Auger, T-205 "C" Cutter, T-210 Grease Cutter, T-217 Drop Head Auger | 33 | 15.0 | 749.00 |

K-3/K-6 TOILET AUGERS

High quality tools in 3' and 6' lengths provide fast and safe clearing of toilet obstructions.

Includes:

- K-6 models telescope for additional reach
- Negotiate water-conserving toilets
- New, durable, kink-resistant, 1.2" compression-wrapped inner core cable
- Large, ergonomically designed handles
- Vinyl guard protects porcelain
- Available in drop head or bulb head models



TNX567

RIDGID

| Model No. | Cat. No. | Mfg. No. | Description | Weight | | Price /Each | Replacement Cable |
|-----------|----------|----------|-----------------------------|--------|-----|-------------|-------------------|
| | | | | lbs. | kg | | |
| TNX567 | 59787 | K-3 | 3' Toilet Auger w/Bulb Head | 4 1/2 | 1.9 | 47.50 | – |
| TNX571 | 59797 | K-6 | 6' Toilet Auger w/Bulb Head | 4 1/2 | 1.9 | 78.50 | TNX668 |
| TNX573 | 59802 | K-6 DH | 6' Toilet Auger w/Drop Head | 4 1/2 | 1.9 | 89.90 | TNX670 |

K-26 HAND SPINNERS

A mid-priced tool ideal for users seeking excellent performance and value.

Includes:

- Slip-resistant collet chuck that clasps/unclasps cable with the flick-of-the-wrist
- 5/16" x 25' hollow core cable with bulb head auger for maximum flexibility
- Rotary moulded plastic drum that won't rust or dent – cleans easily
- Open drum design that permits access to cable and allows application of cable rust inhibitor

RIDGID

| Model No. | Cat. No. | Mfg. No. | Description | Width and Length | | | | Weight | | Price /Each | | |
|-----------|----------|----------|-----------------------------------|------------------|---|-----|----|--------|-----|-------------|------|--------|
| | | | | in. | x | ft. | mm | x | m | | lbs. | kg |
| TNX576 | 59812 | K-26 | Hand Spinner w/C1 Bulb Head Cable | 5/16 | x | 25 | 8 | x | 7.6 | 6 | 2.7 | 127.00 |



TNX576

INSPECTION CAMERAS

MICRO™ CA-300 INSPECTION CAMERAS

Documentation made easy with the new Ridgid® micro™ CA-300 inspection camera. Easily record still images and videos of problems in hard-to reach areas and then share these findings with the RidgidConnect™ solution. Comfortable pistol-grip design, large screen, and rugged anodized aluminum camera head with four bright LEDs make it easy to detect and diagnose the unreachable. Get the perfect view with enhanced features like image rotation and digital zoom.

SPECIFICATIONS:

Display: 3.5" (90 mm) colour TFT
Camera diameter: 7" (17 mm) LCD (320 x 240 resolution)
Lighting: 4 adjustable LEDs
Cable reach: 3' (0.9 m) (Expandable to 30' with optional extension also compatible with microDrain™, microReel™ and nanoReel™)
Images: JPG - Good (640 x 480), Better (1024 x 768), Best (1600 x 1200)
Video: AVI - Good (320 x 240), Best (640 x 480)
External memory: SD card up to 32 GB (4 GB SD card included)
Power source: Rechargeable 3.7 V Li-Ion battery
Included: micro™ CA-300 with 17 mm imager, battery, charger, USB card, hook, magnet and mirror accessories, RCA cable, AC adapter, headset with microphone, 4 GB SD card, 1-year RidgidConnect™ basic subscription



| Model No. | Mfg. No. | Description | Price /Each |
|-----------|----------|---------------------------------|-------------|
| IA844 | 37888 | Micro™ CA-300 Inspection Camera | 679.00 |
| IA841 | 37103 | 17 mm Replacement Imager | 124.00 |
| IA842 | 37108 | 3' Cable Universal Extension | 80.20 |
| IA843 | 37113 | 6' Cable Universal Extension | 147.00 |
| IA845 | 37083 | 3.7 V Li-Ion Battery | 109.00 |
| IA846 | 37098 | 3' (6 m) Imager Head | 179.00 |

SEESNAKE® MICRO™ INSPECTION CAMERAS

The CA-100 inspection camera allows you to perform more detailed visual inspections in even harder-to-reach areas. Its comfortable pistol-grip design, one-hand controls, and large screen make it easy to detect and diagnose the unreachable. The micro™ CA-100 comes standard with a rugged 3/4", 17 mm anodized aluminum camera head with four super bright LEDs. Easily rotate the active image counter-clockwise to see in any situation.

SPECIFICATIONS:

Display: 3.5" colour LCD (320 x 240 resolution)
Camera head: Aluminum 17 mm
Lighting: 4 adjustable LEDs
Cable reach: 3' (Expandable to 30' w/ optional extensions)
Video output: 3' RCA cable (included)
Waterproof: Camera head and cable to 10' (when properly assembled)
Power source: 4 AA batteries
Attachments: Mirror, hook and magnet
Weight: 5.5 lbs (2.5 kg)



| Model No. | Mfg. No. | Description | Price /Each |
|-----------|----------|---------------------------------|-------------|
| IA840 | 36738 | Micro™ CA-100 Inspection Camera | 389.00 |
| IA841 | 37103 | 17 mm Replacement Imager | 124.00 |
| IA842 | 31128 | 3' Cable Universal Extension | 80.20 |
| IA843 | 31133 | 6' Cable Universal Extension | 147.00 |

R9000 PIPE VIDEO INSPECTION SYSTEM

- Designed to deliver quality video inspection in a wide range of applications including: sewers, building ducts/piping, wells, and power plants
- High resolution CCD chip is designed to capture bright, crisp, colour video of the inspection area
- Cable reel is mounted and rotatable in the case, therefore the fiberglass rod cable can be pushed in and out without the need to hold the reel
- Camera head contains 12 white LED lights, a flexible spring coiled joint to navigate corners, a scratch-resistant sapphire lens cover and a stainless steel housing that allows the camera to withstand various hits
- System includes camera head, cable reel, battery pack and DVR
- Sun visor is included to act as a sun shield for outdoor inspections
- Viewing Angle: 140°
- External Memory: Supports SD memory card up to 32GB
- DVR Output: TV and Audio
- DVR Resolution: 800 x 480 RGB
- Display Size: 7"
- Camera Head: 0.9" (23 mm)

Model No. IB751
Mfg. No. R9000
Price/Each \$1595.00



INSPECTION CAMERAS

- Comfortable pistol grip design and forward facing controls make it easy to detect and diagnose the unreachable
- High visibility 3.2" colour TFT LCD monitor with 320 x 240 pixel resolution
- Flexible gooseneck imager head retains configured shape and is waterproof (IP67)
- High visibility 10° adjustable LED lighting
- Camera and video functions allow you to save high resolution JPG images and live video
- Transfer files to a computer via USB cable and optional SD memory card
- Rechargeable lithium-ion battery
- Viewing distance: 15 cm to 25 cm (5.9" to 9.8")
- TV compatible
- Viewing angle: 0 to 180°
- Camera diameter: 17 mm (0.66")
- Gooseneck length: 1 m (39")
- Includes video borescope, imager head, magnet, hook and mirror attachments, 3.7 V lithium battery, DC power supply, USB cable, video output cable, user manual and hard carrying case



| Model No. | Mfg. No. | Description | Price/Each |
|-----------|----------|-------------------------|------------|
| IA674 | BS-150 | Video Inspection Camera | 299.00 |
| OM463 | 167130 | 4 GB SD Memory Card | 14.80 |
| IA679 | BS-C6 | 6' Cable Extension | 75.00 |



KLEIN TOOLS
For Professionals... Since 1857®

Klein insulated tools are NFPA-70 compliant, which is harmonized with CSA-Z462. Klein insulated tools meet and/or exceed the IEC60900 and ASTM F1505 standards. Serious electricians and technicians choose Klein products first due to their high quality and precision. All Klein insulated hand tools are rated for up to **1000 V** and clearly marked with the official **1000 V** rating symbol. High quality coating protects while providing user comfort.

INSULATED ANGLED HEAD DIAGONAL CUTTERS

- High-leverage design for maximum power
- Angled head for easier access in confined areas
- Standard bevel cut design



| Model No. | Mfg. No. | O.A. Length" | Price/Each |
|-----------|--------------|--------------|------------|
| TJ826 | D248-8-INS | 8 | 113.00 |
| TJ827* | D2000-48-INS | 8 | 129.00 |

* Indicates extra tough cutters

INSULATED LONG NOSE WITH SIDE CUTTERS

- High-quality construction
- Powerful side cutters
- Ideal for looping and wrapping wire



| Model No. | Mfg. No. | O.A. Length" | Price/Each |
|-----------|------------|--------------|------------|
| TJ830 | D203-6-INS | 6 5/8 | 86.50 |
| TJ859* | D203-7-INS | 7 1/8 | 96.80 |

* Indicates extra tough cutters

INSULATED HIGH-LEVERAGE SIDE CUTTERS

- Smooth, streamlined nose with knurled jaws
- High-leverage design for maximum power
- Powerful side cutters



| Model No. | Mfg. No. | O.A. Length" | Price/Each |
|-----------|---------------|--------------|------------|
| TJ817 | D213-9NE-INS | 9 1/4 | 131.00 |
| TJ818* | D2000-9NE-INS | 9 1/4 | 148.00 |

* Indicates extra tough side cutters

INSULATED COMPACT CABLE CUTTERS

- One-handed cutting of copper and multi-strand wire
- Provides a clean non-fraying cut
- Not designed for cutting steel or ACSR



| Model No. | Mfg. No. | O.A. Length" | Price/Each |
|-----------|-----------|--------------|------------|
| TJ862 | 63050-INS | 8 | 131.00 |

INSULATED SIDE CUTTERS WITH CRIMPING DIE

- Powerful knurled jaws with toothed pipe grip
- Built-in wire cutters on both sides
- Powerful side cutters



| Model No. | Mfg. No. | O.A. Length" | Price/Each |
|-----------|-----------|--------------|------------|
| TJ819 | 12098-INS | 8 1/2 | 138.00 |

INSULATED CRIMPING TOOLS

- Thin nose design allows access into confined areas
- Works for both insulated and non-insulated crimps
- Accepts wire from 10 to 22AWG
- Wire cutter in nose



| Model No. | Mfg. No. | O.A. Length" | Price/Each |
|-----------|----------|--------------|------------|
| TJ864 | 1005-INS | 9 3/4 | 124.00 |

INSULATED PUMP PLIERS

- Adjustable tongue and groove system
- Pliers adjust to the size of the required work
- Powerful jaws have amazing gripping power



| Model No. | Mfg. No. | O.A. Length" | Price/Each |
|-----------|-------------|--------------|------------|
| TJ860 | D502-10-INS | 10 | 106.00 |



Cimco **1000 V** insulated safety tools are check tested according in IEC60900:2004. The double dip coated insulation (inside: orange, outside: red) guarantees optimal safety. As soon as the outer red coating is damaged, the now visible colour orange with its signal effect call attention to the no longer 100% safety, according to the safety instructions.

COMBINATION PLIERS, 1000 V



THZ380

| Model No. | Mfg. No. | OAL mm | Price/Each |
|-----------|----------|--------|------------|
| THZ380 | 108781 | 165 | 51.60 |
| THZ381 | 108782 | 185 | 54.50 |
| THZ382 | 108783 | 200 | 57.70 |

SIDE CUTTERS W/WIRE STRIPPER 1.5 + 2.5 MM, 1000 V



THZ370

| Model No. | Mfg. No. | OAL mm | Price/Each |
|-----------|----------|--------|------------|
| THZ370 | 108792 | 160 | 74.70 |

HEAVY-DUTY SIDE CUTTERS, 1000 V



THZ372

| Model No. | Mfg. No. | OAL mm | Price/Each |
|-----------|----------|--------|------------|
| THZ371 | 108789 | 170 | 74.10 |
| THZ372 | 108784 | 200 | 83.90 |

SNIP NOSE PLIERS W/STRAIGHT JAWS, 1000 V



THZ377

| Model No. | Mfg. No. | OAL mm | Price/Each |
|-----------|----------|--------|------------|
| THZ376 | 108779 | 165 | 61.90 |
| THZ377 | 108778 | 200 | 67.10 |

INSULATED TOOLS

CABLE STRIPPING KNIVES 1000 V W/HOOK BLADE



| Model No. | Mfg. No. | OAL mm | Price/Each |
|-----------|----------|--------|------------|
| THZ506 | 120044 | 35 | 27.10 |

CABLE STRIPPING KNIVES 1000 V W/INSULATED BLADE BACK



| Model No. | Mfg. No. | OAL mm | Price/Each |
|-----------|----------|--------|------------|
| THZ505 | 120043 | 50 | 34.70 |

INSULATED, SPECIAL PROFILATED PHILLIPS- TIP SCREWDRIVERS

- High quality tempered steel shank and heat-treated tip
- Cushion-grip handle for user comfort



| Model No. | Mfg. No. | Tip No. | Shank Length" | Price/Each |
|-----------|-----------|---------|---------------|------------|
| TV561 | 6334-INS | 1 | 4 | 37.30 |
| TV562 | 603-4-INS | 2 | 4 | 39.80 |
| TLV663 | 6337-INS | 3 | 6 | 43.70 |

INSULATED, SLOT CABINET TIP SCREWDRIVERS

- High quality tempered steel shank and heat-treated tip
- Cushion-grip handle for user comfort



| Model No. | Mfg. No. | Tip Width" | Shank Length" | Price/Each |
|-----------|-----------|------------|---------------|------------|
| TV558 | 601-4-INS | 3/16 | 4 | 38.20 |
| TNB726 | 601-7-INS | 3/16 | 7 | 39.80 |

INSULATED, SQUARE RECESS TIP SCREWDRIVERS

- High quality tempered steel shank and heat-treated tip
- Cushion-grip handle for user comfort



| Model No. | Mfg. No. | Tip No. | Shank Length" | Price/Each |
|-----------|-----------|---------|---------------|------------|
| TLV674 | 661-7-INS | 1 | 7 | 39.30 |
| TLV675 | 662-7-INS | 2 | 7 | 38.90 |

INSULATED HEAVY-DUTY, SLOT KEYSTONE TIP SCREWDRIVERS

- High quality tempered steel shank and heat-treated tip
- Cushion-grip handle for user comfort

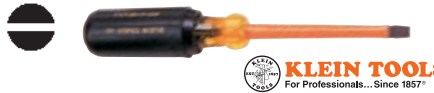

| Model No. | Mfg. No. | Tip Width" | Shank Length" | Price/Each |
|-----------|-----------|------------|---------------|------------|
| TV555 | 602-4-INS | 1/4 | 4 | 39.90 |
| TLV551 | 602-8-INS | 3/8 | 8 | 56.20 |

PHILLIPS SCREWDRIVERS, 1000 V



| Model No. | Mfg. No. | Tip No. | Shank Length" | Price/Each |
|-----------|----------|---------|---------------|------------|
| THZ394 | 117730 | 0 | 60 | 9.32 |
| THZ395 | 117731 | 1 | 80 | 11.50 |
| THZ396 | 117732 | 2 | 1000 | 15.40 |
| THZ397 | 117733 | 3 | 150 | 20.70 |

ELECTRICIAN'S SCREWDRIVERS, 1000 V



| Model No. | Mfg. No. | OAL mm | Tip mm | Shank Length" | Price/Each |
|-----------|----------|--------|----------|---------------|------------|
| THZ386 | 117701 | 155 | 2.5x0.4 | 75 | 9.32 |
| THZ387 | 117702 | 180 | 3.0x0.5 | 100 | 9.23 |
| THZ388 | 117703 | 185 | 3.5x0.6 | 100 | 10.60 |
| THZ389 | 117704 | 185 | 4.0x0.8 | 100 | 10.30 |
| THZ390 | 117705 | 225 | 5.5x1.0 | 125 | 14.10 |
| THZ391 | 117706 | 250 | 6.5x1.2 | 150 | 17.20 |
| THZ392 | 117708 | 285 | 8.0x1.2 | 175 | 17.20 |
| THZ393 | 117710 | 315 | 10.0x1.6 | 200 | 27.70 |

INSULATED HOLLOW SHAFT NUT DRIVERS

- Full length insulation on shaft
- Hollow shaft to fit over long screws
- Cushion-grip handle for user comfort



| Model No. | Mfg. No. | Hex Size" | Shank Length" | Price/Each |
|-----------|---------------|-----------|---------------|------------|
| TLV665 | 646-3/16-INS | 3/16 | 6 | 37.70 |
| TLV666 | 646-1/4-INS | 1/4 | 6 | 38.10 |
| TLV667 | 646-5/16-INS | 5/16 | 6 | 38.30 |
| TLV668 | 646-11/32-INS | 11/32 | 6 | 38.80 |
| TLV669 | 646-3/8-INS | 3/8 | 6 | 39.20 |
| TLV670 | 646-7/16-INS | 7/16 | 6 | 42.80 |
| TLV671 | 646-1/2-INS | 1/2 | 6 | 44.50 |
| TLV672 | 646-9/16-INS | 9/16 | 6 | 50.60 |
| TLV673 | 646-5/8-INS | 5/8 | 6 | 56.60 |

INSULATED ALLEN KEY SETS

SAE

- 14-piece insulated SAE long arm set
- Double insulated for use in 1000 V environments
- Included sizes: 1/16", 5/64", 3/32", 7/64", 1/8", 9/64", 5/32", 3/16", 7/32", 1/4", 5/16", 3/8", 7/16", 1/2"
- Includes a black ballistic nylon fold-over pouch with velcro closures

Model No. TLZ719 Mfg. No. HWS-14L Price/Each \$561.00

METRIC

- 13-piece insulated metric long arm set
- Double insulated for use in 1000 V environments
- Included sizes (mm): 1.5, 2, 2.5, 3, 4, 5, 6, 7, 8, 9, 10, 11, 12 mm
- Includes a black ballistic nylon fold-over pouch with velcro closures

Model No. TLZ731 Mfg. No. MHWS-13L Price/Each \$666.00



TLZ719

BASIC INSULATED 8-PIECE TOOL KITS

- Individually tested to exceed standards
- Two layers of insulation provide protection against electric shock
- Highly durable, black, nylon case features: coil-zipper closure, polypropylene handles, custom-fitted tool pockets
- Overall case dimensions are: 15 1/2" W x 11" D x 2 1/2" H

Kit contains an assortment of eight popular insulated tools:

- 3 insulated pliers (side-cutting, diagonal-cutting, long nose – side-cutting)
- 3 insulated screwdrivers (cabinet 3/16" x 6", keystone 1/4" x 4", Phillips No. 2)
- 1 insulated high-leverage cable cutter
- 1 insulated wire stripper/cutter
- 1 heavy-duty polyester case

Model No. TTW005
Mfg. No. 33526
Price/Each \$849.00



CUSHION-GRIP INSULATED 9-PIECE SCREWDRIVER KITS

- Individually tested to exceed standards
- Two layers of insulation provide protection against electric shock
- Highly durable, black, nylon case features: coil-zipper closure, polypropylene handles, custom-fitted tool pockets
- Overall case dimensions are: 15 1/2" W x 11" D x 2 1/2" H

Kit contains an assortment of 9 screwdrivers: 3 insulated cabinet screwdrivers (3/16" x 4", 3/16" x 6", 3/16" x 8"), 3 insulated keystone screwdrivers (1/4" x 4", 5/16" x 6", 3/8" x 10"), 3 insulated Phillips screwdrivers (No. 1, No. 2, No. 3), 1 heavy-duty polyester case.

Model No. TBS956
Mfg. No. 33528
Price/Each \$523.00



KNIPLEX® 5 PC. INSULATED TRADESMAN SET

- IEC 60900 and ASTM F1505 certified
- 8" high leverage diagonal cutting pliers
- 9" high leverage combination pliers
- MAXXPRO VDE Slotted (7/32") 5.5mm x 125mm
- MAXXPRO VDE Phillips #2 x 100mm
- MAXXPRO VDE Square #2 x 100mm
- Voltage Rating: 1000 V

Model No. TYO794
Price/Each \$179.00



UTILITY INSULATED 13-PIECE TOOL KITS

- Individually tested to exceed standards
- Two layers of insulation provide protection against electric shock
- The custom case includes two pallets with custom-fitted pockets for each tool, both a combination lock and two key-locked latches for security
- Overall case dimensions are: 18 7/8" W x 15 3/8" D x 8 1/4" H

Kit contains an assortment of 13 professional, insulated tools:

- 5 insulated pliers (side-cutting, diagonal-cutting, diagonal-cutting – angled head, long-nose – side-cutting, pump pliers)
- 6 insulated screwdrivers (Keystone 1/4" x 4", 5/16" x 6", 3/8" x 10", Phillips No. 1, No. 2, No. 3)
- 1 insulated high-leverage cable cutter
- 1 insulated cable/lineman's skinning knife
- 1 extra-sturdy, bright-yellow case

Model No. TTW001
Mfg. No. 33525
Price/Each \$1497.00



KNIPLEX® 10 PC. INSULATED TOOL SET

- IEC 60900 and ASTM F1505 certified
- 9" high leverage combination pliers
- 8" long nose side cutting pliers
- 8" high leverage diagonal cutting pliers
- 10" Alligator® water pump pliers
- 6-1/4" cable shears
- MAXXPRO VDE Slotted (5/32") 4mm x 100mm
- MAXXPRO VDE Square #2 x 100mm
- MAXXPRO VDE Slotted (1/4") 6.5mm x 150mm
- MAXXPRO VDE Phillips #2 x 100mm
- MAXXPRO VDE Phillips #1 x 80mm

Model No. TYO799
Price/Each \$399.00



7-PC. SCREWDRIVER SETS, 1000 V

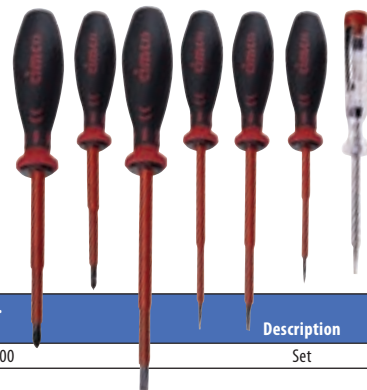

| Model No. | Mfg. No. | Description | Price /Each |
|-----------|----------|-------------|-------------|
| THZ426 | 117800 | Set | 74.40 |

INCLUDES

| Model No. | Mfg. No. | OAL mm | Tip | Price /Each |
|-----------|----------|--------|-----------|-------------|
| THZ386 | 117701 | 75 | 2.5 x 0.4 | 9.32 |
| THZ387 | 117702 | 100 | 3.0 x 0.5 | 9.23 |
| THZ389 | 117704 | 100 | 4.0 x 0.8 | 10.30 |
| THZ390 | 117705 | 125 | 5.5 x 1.0 | 14.10 |
| THZ395 | 117731 | 80 | PH1 | 11.50 |
| THZ396 | 117732 | 100 | PH2 | 15.40 |
| THZ425 | 111280 | 50 | 3.0 | 3.89 |

NON-SPARKING, NON-MAGNETIC TOOLS



Ampco non-sparking, non-magnetic, corrosion-resistant safety tools are FM approved. Made in the U.S.A. Backed by a limited lifetime warranty. Effectively limit sparking and meet OSHA's New Hazard Communication Standard stating that non-sparking tools are required with flammable liquids. Non-sparking tools for use in locations where flammable vapours and/or combustible residues are present. Non-sparking or intrinsically safe tools are also required and/or recommended by NFPA, MSHA and NIOSH.

Ideal for petroleum, metalworking, paint finishing, and transportation applications. Also used in woodworking, fertilizer production, and grain handling where high levels of dust are prominent. The metals used to make Ampco Safety Tools are highly conductive and should be grounded if there is a risk for static sparks.

Non-sparking metal - High-strength for impact and torque applications. Brinell hardness is 200 to 350. Tensile strength is 95 000 to 150 000 PSI.

Beryllium Copper* - Superior strength for impact and torque applications. Most effective material for tools with cutting edges or gripping teeth. Brinell hardness is 332 to 382. Tensile strength is up to 200 000 PSI.

* All models made from non-sparking metal, some contain beryllium copper where indicated.



WRECKING & PRYING BARS

Cast from a high-strength nickel-aluminum bronze. Ideal for handling potentially flammable or hazardous items.



| Model No. | Description | Bar Size" | Overall Length" | Wt. lbs. | Price /Each |
|-----------|---|-----------|-----------------|----------|-------------|
| TP415 | Hammer/Claw Crate Opener Stock: 3/4"W x 0.339" Thick | 2 3/4 | 9 | 0.94 | 96.40 |
| TP416 | Nail Puller Shank dia.: 0.705"; Jaw Width: 0.325" | | 18 | 4.0 | 534.00 |
| TP417 | Crow Bar | 5/8 Hex. | 18 | 1.9 | 199.00 |
| TP418 | Crow Bar | 3/4 Hex. | 24 | 3.8 | 252.00 |
| TP419 | Crow Bar | 7/8 Hex. | 30 | 6.0 | 357.00 |
| TP420 | Crow Bar | 7/8 Hex. | 36 | 7.2 | 352.00 |
| TP421 | Pinch Bar w/Bent Chisel Tip | 3/4 Hex. | 18 | 2.3 | 93.40 |
| TP422 | Pinch Bar w/Bent Chisel Tip | 7/8 Hex. | 30 | 5.1 | 274.00 |
| TP423 | Pinch Bar w/Bent Chisel Tip | 1 Hex. | 36 | 8.7 | 420.00 |
| TP424 | Pry bar w/Straight Chisel Tip | 1 1/4 | 60 | 18.8 | 860.00 |
| TP425 | Pry bar w/Straight Chisel Tip | 1 3/8 | 68 | 24.5 | 1269.00 |



HAMMERS & MALLETS

Non-sparking metal construction, cast from a high strength nickel-aluminum bronze. Fibreglass handle for durability and vibration control.



| Model No. | Description | Head Wt. lbs. | Face Dia." | Overall Length" | Price /Each |
|-----------|---|---------------|------------|-----------------|-------------|
| BB512 | Curved-Claw Nail Hammer Smooth Striking Face | 0.75 | 5/8 | 14 | 121.00 |
| BB514 | Curved-Claw Nail Hammer Smooth Striking Face | 1.00 | 1 | 14 | 119.00 |
| BB517 | Curved-Claw Nail Hammer Smooth Striking Face | 1.25 | 1 | 14 | 181.00 |
| BB486 | Ball Pein Hammer | 0.25 | 3/8 | 9 3/4 | 73.70 |
| BB487 | Ball Pein Hammer | 0.75 | 1 | 14 | 96.40 |
| BB488 | Ball Pein Hammer | 1.00 | 1 1/4 | 14 | 99.90 |
| BB489 | Ball Pein Hammer | 1.50 | 1 3/8 | 14 | 112.00 |
| BB490 | Ball Pein Hammer | 2.00 | 1 1/4 | 14 | 134.00 |
| BB491 | Ball Pein Hammer | 2.25 | 1 5/8 | 14 | 163.00 |
| BB492 | Ball Pein Hammer | 2.75 | 1 3/4 | 14 | 165.00 |
| BB498 | Double-Face Engineer's Hammer | 1.75 | 1 3/8 | 14 | 136.00 |
| BB503 | Double-Face Engineer's Hammer | 2.25 | 1 3/8 | 14 | 149.00 |
| BB504 | Double-Face Engineer's Hammer | 2.75 | 1 1/2 | 15 | 182.00 |
| BB509 | Double-Face Engineer's Hammer | 3.00 | 1 1/2 | 15 | 199.00 |
| WI940 | Sledge Hammer | 3.00 | 1 3/4 | 15 | 225.00 |
| WI941 | Sledge Hammer | 6.00 | 2 | 33 | 299.00 |
| WI942 | Sledge Hammer | 7.50 | 2 1/4 | 33 | 447.00 |
| WI943 | Sledge Hammer | 10.00 | 2 3/8 | 33 | 514.00 |
| WI944 | Sledge Hammer | 16.00 | 2 3/4 | 33 | 743.00 |
| WI945 | Sledge Hammer | 18.00 | 3 | 33 | 1054.00 |
| WI953 | Mallet | 2.00 | 1 1/2 | 14 | 138.00 |
| WI954 | Mallet | 4.00 | 2 | 15 | 204.00 |
| WI955 | Mallet | 6.00 | 2 1/4 | 15 | 333.00 |
| BB497 | Bricklayer's Hammer | 1.50 | 3/4 | 14 | 184.00 |
| BB541 | Scaling Hammer | 1.00 | 1 x 1/8 | 14 | 133.00 |



NON-SPARKING, NON-MAGNETIC TOOLS

CLAY PICKS

Cast from a high strength nickel-aluminum bronze.
Eye opening size is 1 5/8" W x 2 1/2" L.



| Model No. | Head Wt. lbs. | Head Length" | Price/Each |
|-----------|-------------------|--------------|------------|
| TP464 | 4 1/2 | 21 | 341.00 |
| TP465 | 6 3/4 | 25 | 374.00 |
| TP466 | 10 2/5 | 27 1/2 | 872.00 |
| TP467* | Fiberglass Handle | 36" | 64.60 |

* Fiberglass handle sold separately

SAFETY FLANGE WEDGES

Cast from high strength nickel-aluminum bronze



TLV219



| Model No. | Mfg. No. | Dimensions | | | Price /Each |
|-----------|----------|-----------------------|--|--|-------------|
| | | L" x W" x H" | | | |
| TLV212 | W-1 | 3 1/4 x 1/2 x 1/4 | | | 18.90 |
| TLV213 | W-2 | 3 1/4 x 3/4 x 1/2 | | | 18.90 |
| TLV214 | W-3 | 6 x 1 x 1/2 | | | 26.10 |
| TLV215 | W-4 | 6 x 1 1/2 x 3/4 | | | 42.60 |
| TLV216 | W-5 | 7 x 1 1/4 x 1/2 | | | 35.50 |
| TLV217 | W-6 | 7 x 2 x 3/4 | | | 68.30 |
| TLV218 | W-7 | 7 3/4 x 1 1/2 x 1 5/8 | | | 93.90 |
| TLV219 | W-8 | 8 x 1 1/2 x 1 | | | 73.90 |
| TLV220 | W-9 | 8 x 2 x 3/4 | | | 75.50 |
| TLV221 | W-10 | 8 1/2 x 2 x 1 1/4 | | | 99.90 |
| TLV222 | W-11 | 7 x 2 x 3/8 | | | 52.30 |
| TLV223 | W-12 | 3 1/2 x 2 x 3/8 | | | 36.20 |
| TLV224 | W-13 | 8 x 2 x 2 | | | 243.00 |

SHOVELS & SCOOPS

Non-sparking metal construction. One-piece blade, hollow-socket shovels and scoops. High strength and manageable weight allow for continuous and effective use. Long-handled models have fiberglass handles and D-handled models have fiberglass handles with a plastic grip bar.

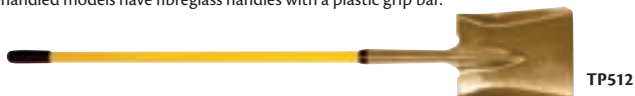

TP512



TP511

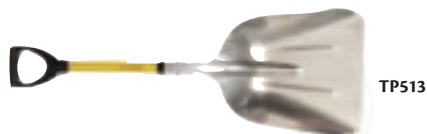

TP513



TP510

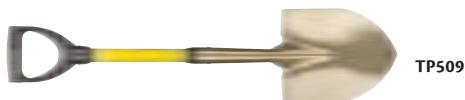

TP509

| Model No. | Blade Size | | | Handle Style | Overall Length" | Price /Each |
|-----------------------------|------------|---|--------|--------------|-----------------|-------------|
| | W" | x | H" | | | |
| ROUND-POINT SHOVELS | | | | | | |
| TP509 | 9 | x | 11 1/4 | D | 37 | 388.00 |
| TP510 | 9 | x | 11 1/4 | Long | 56 1/2 | 399.00 |
| SQUARE-POINT SHOVELS | | | | | | |
| TP511 | 9 | x | 11 | D | 37 | 446.00 |
| TP512 | 9 | x | 11 | Long | 58 | 451.00 |
| SCOOP SHOVELS | | | | | | |
| TP513 | 14 | x | 17 | D | 40 | 196.00 |
| TP514 | 14 | x | 17 | Long | 60 1/2 | 199.00 |

BANANA WEDGES

- Cast from high strength nickel-aluminum bronze
- Length: 12-1/4"
- Width: 13/16"
- Height: 4-1/16"

Model No. TYO567
Mfg. No. BW-1
Price/Each \$249.00



CHISELS

- Cast from a high strength nickel-aluminum bronze
- Hexagonal shank



HAND CHISELS

| Model No. | a" | b" | c" | Price/Each |
|-----------|--------|-----|-------|------------|
| TP493 | 1/4 | 1/4 | 5 1/4 | 34.30 |
| TP494 | 7/16 | 3/8 | 5 3/4 | 45.90 |
| TP495 | 9/16 | 1/2 | 6 1/2 | 35.30 |
| TP496 | 3/4 | 5/8 | 6 | 45.60 |
| TP497 | 13/16 | 3/4 | 8 | 58.50 |
| TP498 | 11/16 | 5/8 | 9 1/8 | 62.90 |
| TP499 | 3/4 | 3/4 | 9 | 69.10 |
| TP500 | 7/8 | 7/8 | 9 | 77.20 |
| TP501 | 1 1/16 | 1 | 9 1/4 | 92.60 |
| TP502 | 9/16 | 1/2 | 12 | 59.50 |
| TP503 | 7/8 | 3/4 | 12 | 82.70 |
| TP504 | 1 | 7/8 | 30 | 369.00 |

NON-SPARKING, NON-MAGNETIC TOOLS



PUTTY KNIVES & SPATULAS

- Made from nickel copper
- Use with volatile resins, paints, inks and other compounds
- Blade is riveted to wood handle



| Model No. | a" | b" | c" | Price /Each |
|-------------------------------------|-------|--------|--------|-------------|
| PUTTY KNIVES - STIFF BLADE | | | | |
| TX710 | 1 1/4 | 3 9/16 | 7 3/4 | 31.90 |
| TX711 | 2 | 4 | 8 | 42.10 |
| TX712 | 3 1/2 | 4 1/2 | 8 1/2 | 61.20 |
| PUTTY KNIFE - FLEXIBLE BLADE | | | | |
| TX713 | 3 1/2 | 4 1/2 | 8 1/2 | 66.20 |
| SPATULAS | | | | |
| TX714 | 1 | 6 | 10 1/4 | 50.50 |
| TX715 | 1 1/2 | 9 | 14 | 96.80 |
| TX716 | 2 | 14 | 19 1/4 | 127.00 |

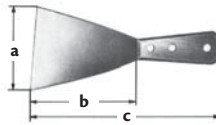

HAND SCRAPERS

- Cast from a high strength nickel-aluminum bronze
- Choose from a variety of models



| Model No. | Description | Blade Size | | | O.A. Length" | Price /Each |
|-----------|--|------------|---|-------|--------------|-------------|
| | | L" | x | W" | | |
| TP474 | Spray Booth Scraper | 4 | X | 3 | 9 1/4 | 61.60 |
| TP475 | Pick and Scaler Scraper | 2 1/4 | X | 3 | 17 3/4 | 118.00 |
| TP476 | Hand Styler Scraper W/Plastic Handle | 3 3/4 | X | 3 3/4 | 19 | 205.00 |
| TP477 | Deck Scraper w/Single Blade and Handle | - | - | 1 1/2 | 15 | 144.00 |
| TP478 | Deck Scraper w/Blade on Each End | - | - | 7/8 | 7 7/8 | 47.30 |
| TP479 | Deck Scraper w/Blade on Each End | - | - | 2 | 12 | 75.20 |

TP474

TP475

TP476

TP477

TP478

SCRAPERS

- Cast from a high strength nickel-aluminum bronze
- Fibreglass handle sold separately



| Model No. | Description | Blade Size | | | O.A. Length" | Price /Each |
|-----------|-------------------------------------|------------|---|----|--------------|-------------|
| | | L" | x | W" | | |
| TP480 | Scraper, Short Blade | 1 1/2 | X | 3 | 7 | 89.10 |
| TP481 | Scraper, Short Blade | 1 1/2 | X | 4 | 7 | 133.00 |
| TP482 | Scraper, Short Blade | 1 1/4 | X | 5 | 7 | 148.00 |
| TP483 | Scraper, Short Blade | 1 1/2 | X | 6 | 6 3/4 | 129.00 |
| TP485 | Scraper, Long Blade | 2 1/2 | X | 4 | 9 | 117.00 |
| TP486 | Scraper, Long Blade | 2 1/2 | X | 5 | 9 | 141.00 |
| TP487 | Scraper, Long Blade | 2 1/4 | X | 6 | 8 1/2 | 129.00 |
| TP489 | Plain Floor Scraper | 6 3/4 | X | 6 | 6 3/4 | 129.00 |
| TP469 | Fibreglass Handle for Floor Scraper | - | - | - | 65 | 59.90 |

TP480

TP489

KNIVES

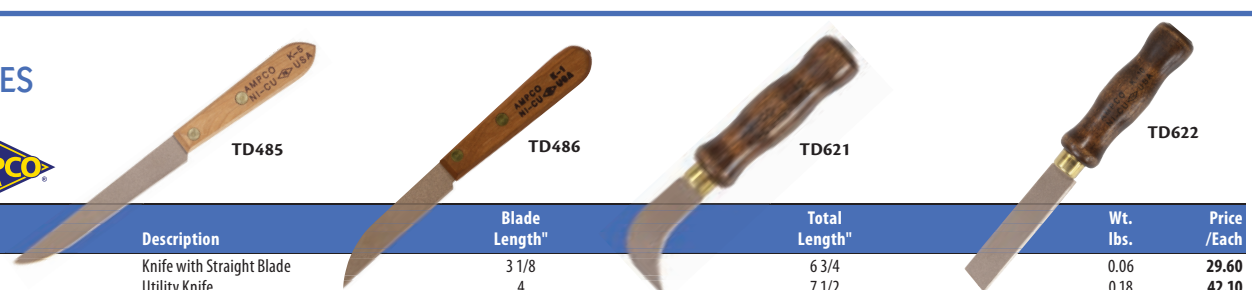

TD485

TD486

TD621

TD622

| Model No. | Description | Blade Length" | Total Length" | Wt. lbs. | Price /Each |
|-----------|---------------------------|---------------|---------------|----------|-------------|
| TD486 | Knife with Straight Blade | 3 1/8 | 6 3/4 | 0.06 | 29.60 |
| TD622 | Utility Knife | 4 | 7 1/2 | 0.18 | 42.10 |
| TD485 | Knife with Curved Blade | 5 3/4 | 10 1/4 | 0.17 | 48.70 |
| TD621 | Linoleum Knife | 4 9/16 | 7 1/2 | 0.18 | 79.90 |

NON-SPARKING, NON-MAGNETIC TOOLS

SCREWDRIVERS

- Beryllium copper shanks

| Model No. | Type | a" | b" | c" | Wt. lbs. | Price /Each |
|-----------------|------|------|----|--------|----------|-------------|
| STANDARD | | | | | | |
| TD625 | - | 1/8 | 6 | 9 1/2 | 0.12 | 30.90 |
| TD613 | - | 5/16 | 3 | 6 1/2 | 0.14 | 32.90 |
| TD614 | - | 5/16 | 6 | 10 1/8 | 0.3 | 51.10 |
| TD615 | - | 3/8 | 8 | 13 | 0.5 | 72.70 |
| TD616 | - | 3/8 | 12 | 17 | 0.64 | 85.70 |
| PHILLIPS | | | | | | |
| TD617 | #1 | - | 3 | 6 1/2 | 0.12 | 25.50 |
| TD618 | #2 | - | 4 | 7 1/2 | 0.16 | 32.20 |
| TD619 | #3 | - | 6 | 10 1/8 | 0.3 | 50.10 |
| TD620 | #4 | - | 8 | 13 | 0.5 | 69.90 |

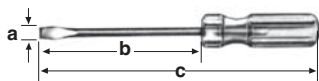

| Model No. | a" | b" | c" | Wt. lbs. | Price /Each |
|--------------------|------|-------|---------|----------|-------------|
| CABINET-TIP | | | | | |
| TD623 | 1/4 | 4 | 5 5/8 | 0.14 | 34.40 |
| TD624 | 3/16 | 3 1/2 | 7 5/8 | 0.14 | 31.90 |
| TD626 | 3/16 | 6 | 11 5/8 | 0.16 | 41.60 |
| TD627 | 3/8 | 12 | 20 3/16 | 0.75 | 128.00 |



6-PC. SCREWDRIVER SETS

- Non-sparking, non-magnetic, corrosion-resistant screwdriver set
- Beryllium copper shanks

Model No. TLZ291
Mfg. No. M-39
Price/Each \$261.00



MAINTENANCE BRUSHES

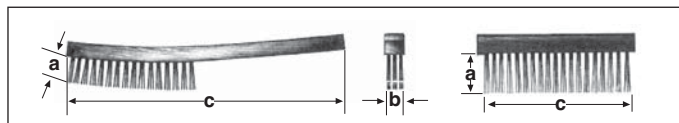

INCLUDES:

| Model No. | Mfg. No. | Description |
|-----------|----------|-------------------------------------|
| TD613 | S-48 | Std Screwdriver 5/16" Tip, 3" Blade |
| TD614 | S-49 | Std Screwdriver 5/16" Tip, 6" Blade |
| TD615 | S-50 | Std Screwdriver 3/8" Tip, 8" Blade |
| TD617 | S1099A | #1 Phillips Screwdriver |
| TD618 | S1099 | #2 Phillips Screwdriver |
| TD619 | S1100 | #3 Phillips Screwdriver |



| Model No. | Description | a" | b" | c" | Wt. lbs. | Price/Each |
|-----------|-----------------------------|-------|-------|--------|----------|------------|
| TD465 | Round-Wire Push Broom | 2 1/2 | 2 1/2 | 12 | 2.2 | 236.00 |
| TD466 | Shoe-Handle Scratch Brush | 1 1/8 | 1 1/8 | 10 | 0.42 | 53.40 |
| TD467 | Curved-Handle Scratch Brush | 1 1/8 | 1 1/8 | 13 3/4 | 0.55 | 48.20 |
| TD468 | Flat-Back Scratch Brush | 1 3/4 | 2 1/4 | 7 1/4 | 0.88 | 96.80 |
| UQ914 | Toothbrush Style | 1/2 | 1/2 | 7 7/8 | 0.1 | 7.99 |

HEX KEYS

- Made of beryllium copper

| Model No. | Hex Key Size" | Wt. lbs. | Price/Each |
|-----------|---------------|----------|------------|
| TD628 | 1/16 | 0.01 | 11.30 |
| TD629 | 5/64 | 0.02 | 12.00 |
| TD630 | 3/32 | 0.02 | 12.30 |
| TD631 | 1/8 | 0.02 | 12.80 |
| TD632 | 5/32 | 0.02 | 14.10 |
| TD633 | 3/16 | 0.04 | 16.70 |
| TD634 | 7/32 | 0.06 | 22.20 |
| TD635 | 1/4 | 0.08 | 27.80 |
| TD636 | 5/16 | 0.14 | 33.60 |
| TD637 | 3/8 | 0.24 | 45.90 |
| TD644 | Hex key set | 0.7 | 210.00 |



PLIERS

Cast from a high-strength nickel-aluminum bronze. Cushion-grip handle provides powerful leverage, comfort and added safety.



| Model No. | Description | Jaw Width" | Overall Length" | Price /Each |
|-----------|--|------------|-----------------|-------------|
| TP452 | Combination Slip-Joint Pliers | 5/16 | 6 1/2 | 111.00 |
| TP453 | Combination Slip-Joint Pliers | 1/2 | 8 | 124.00 |
| TP454 | Lineman's Pliers w/Side Cutter | 5/8 | 8 1/2 | 217.00 |
| TP455 | Tongue and Groove Pliers, 6 Positions | 1 1/2 | 10 | 217.00 |
| TP456 | Tongue and Groove Pliers, 6 Positions | 2 1/8 | 12 | 263.00 |
| TLV205 | Diagonal Cutting Pliers | 5/8 | 7 | 248.00 |
| TP457 | Long-Nose Pliers w/Side Cutter, 1/8" Jaw Tip | 1/3 | 7 | 186.00 |



NON-SPARKING, NON-MAGNETIC TOOLS

COMBINATION WRENCHES

- 15° angle and 12-point box

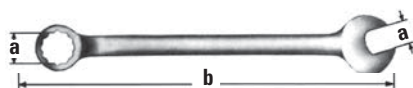

| Model No. | a" | b" | Price/Each |
|-----------|--------|----------|------------|
| TX692 | 3/8 | 6 5/16 | 87.30 |
| TX693 | 7/16 | 7 1/4 | 87.30 |
| TX694 | 1/2 | 7 1/4 | 89.60 |
| TX695 | 9/16 | 8 1/4 | 95.50 |
| TX696 | 5/8 | 8 7/8 | 105.00 |
| TX697 | 11/16 | 10 1/8 | 114.00 |
| TX698 | 3/4 | 10 1/8 | 123.00 |
| TX699 | 7/8 | 13 1/4 | 149.00 |
| TX700 | 15/16 | 13 1/4 | 168.00 |
| TX701 | 1 | 13 1/4 | 191.00 |
| TX702 | 1 1/16 | 17 | 191.00 |
| TX703 | 1 1/8 | 17 | 218.00 |
| TX704 | 1 1/4 | 19 1/2 | 246.00 |
| TX705 | 1 5/16 | 16 15/16 | 246.00 |
| TX706 | 1 3/8 | 21 1/4 | 278.00 |
| TX707 | 1 7/16 | 21 1/4 | 278.00 |
| TX708 | 1 1/2 | 22 | 278.00 |
| TX709 | 1 5/8 | 22 | 316.00 |

ADJUSTABLE WRENCHES



| Model No. | a" max. | b" | Price/Each |
|-----------|---------|----|------------|
| TX679 | 15/16 | 6 | 122.00 |
| TX680 | 1 1/8 | 8 | 139.00 |
| TX681 | 1 5/16 | 10 | 191.00 |
| TX682 | 1 1/2 | 12 | 244.00 |
| TX683 | 1 11/16 | 15 | 440.00 |

ADJUSTABLE PIPE WRENCHES

- Cast from nickel-aluminum bronze (teeth made of beryllium copper)
- Available with aluminum handles

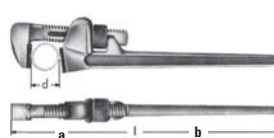

| Model No. | Jaw Material | Handle Material | a" max. | b" | Price/Each |
|-----------|------------------------|------------------------|---------|----|------------|
| TX684 | Nickel-Aluminum Bronze | Nickel-Aluminum Bronze | 1 15/16 | 8 | 307.00 |
| TX685 | Nickel-Aluminum Bronze | Nickel-Aluminum Bronze | 2 1/2 | 10 | 327.00 |
| TX686 | Nickel-Aluminum Bronze | Nickel-Aluminum Bronze | 2 13/16 | 14 | 413.00 |
| TX687 | Nickel-Aluminum Bronze | Nickel-Aluminum Bronze | 3 3/16 | 18 | 459.00 |
| TX688 | Nickel-Aluminum Bronze | Nickel-Aluminum Bronze | 4 1/4 | 24 | 640.00 |
| TX689 | Nickel-Aluminum Bronze | Nickel-Aluminum Bronze | 5 11/16 | 36 | 1159.00 |
| TX690 | Nickel-Aluminum Bronze | Nickel-Aluminum Bronze | 7 9/16 | 48 | 1999.00 |
| TLV206 | Nickel-Aluminum Bronze | Aluminum | 2 1/2 | 10 | 339.00 |
| TLV207 | Nickel-Aluminum Bronze | Aluminum | 2 13/16 | 14 | 444.00 |
| TLV208 | Nickel-Aluminum Bronze | Aluminum | 3 3/16 | 18 | 474.00 |
| TLV209 | Nickel-Aluminum Bronze | Aluminum | 4 1/4 | 24 | 576.00 |
| TLV210 | Nickel-Aluminum Bronze | Aluminum | 5 11/16 | 36 | 982.00 |
| TLV211 | Nickel-Aluminum Bronze | Aluminum | 7 9/16 | 48 | 1896.00 |

BUNG WRENCHES

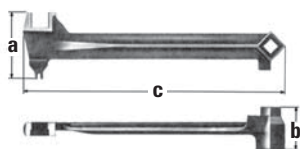

| Model No. | Description | a" | b" | c" | Price/Each |
|-----------|-----------------------------|-------|-------|----|------------|
| UQ924 | For 3/4 and 2" bungs | 2 | 2 | 12 | 73.60 |
| TX691 | For 22 different bung sizes | 2 1/2 | 2 1/4 | 15 | 145.00 |

7-PC. COMBINATION WRENCH SETS

Non-sparking, non-magnetic, corrosion-resistant combination wrench set.

Model No. TLZ292

Mfg. No. M-41

Price/Each \$779.00



INCLUDES:

| Model No. | Mfg. No. | Description |
|-----------|----------|--------------------------|
| TX692 | W-601 | 3/8" Combination Wrench |
| TX693 | W-611 | 7/16" Combination Wrench |
| TX694 | W-621 | 1/2" Combination Wrench |
| TX695 | W-631 | 9/16" Combination Wrench |
| TX696 | W-641 | 5/8" Combination Wrench |
| TX698 | W-661 | 3/4" Combination Wrench |
| TX699 | W-671 | 7/8" Combination Wrench |

Note: Metric sizes available



NON-SPARKING, NON-MAGNETIC TOOLS

SOCKETS



| Model No. | Size mm | Length mm | Price /Each |
|--|---------|-----------|-------------|
| 1/4" DRIVE INDIVIDUAL SOCKET, 6 POINT | | | |
| TD494 | 4 | 13 | 75.30 |
| TD495 | 4.5 | 13 | 75.30 |
| TD496 | 5 | 13 | 75.30 |
| TD497 | 5.5 | 13 | 75.30 |
| TD498 | 6 | 13 | 75.30 |
| TD499 | 7 | 13 | 75.30 |
| TD500 | 8 | 16 | 75.50 |
| TD501 | 9 | 16 | 76.20 |
| TD502 | 10 | 17 | 77.60 |
| TD503 | 11 | 17 | 79.90 |
| TD504 | 12 | 21 | 81.40 |
| TD505 | 13 | 21 | 81.40 |
| TD506 | 14 | 22 | 85.90 |

| | | | |
|--|----|----|--------|
| 1/2" DRIVE INDIVIDUAL SOCKET, 6 POINT | | | |
| TD507 | 8 | 30 | 69.90 |
| TD508 | 9 | 30 | 70.70 |
| TD509 | 10 | 30 | 70.70 |
| TD510 | 11 | 30 | 71.20 |
| TD511 | 12 | 30 | 72.40 |
| TD512 | 13 | 30 | 72.40 |
| TD513 | 14 | 30 | 73.50 |
| TD514 | 15 | 30 | 74.50 |
| TD515 | 16 | 37 | 79.10 |
| TD516 | 17 | 37 | 81.90 |
| TD517 | 18 | 37 | 86.10 |
| TD518 | 19 | 37 | 86.10 |
| TD519 | 20 | 38 | 96.10 |
| TD520 | 21 | 38 | 97.60 |
| TD521 | 22 | 38 | 114.00 |
| TD522 | 23 | 38 | 116.00 |
| TD523 | 24 | 38 | 116.00 |
| TD524 | 25 | 38 | 130.00 |
| TD525 | 26 | 38 | 140.00 |
| TD526 | 27 | 38 | 140.00 |
| TD527 | 28 | 41 | 144.00 |
| TD528 | 29 | 41 | 169.00 |
| TD529 | 30 | 41 | 169.00 |
| TD530 | 32 | 41 | 169.00 |

| | | | |
|--|----|----|--------|
| 3/4" DRIVE INDIVIDUAL SOCKET, 6 POINT | | | |
| TD531 | 30 | 48 | 226.00 |
| TD532 | 33 | 49 | 260.00 |
| TD533 | 34 | 49 | 260.00 |
| TD534 | 35 | 49 | 260.00 |
| TD535 | 36 | 49 | 271.00 |
| TD536 | 37 | 52 | 271.00 |
| TD537 | 38 | 52 | 273.00 |
| TD538 | 41 | 52 | 294.00 |
| TD539 | 42 | 57 | 306.00 |
| TD540 | 46 | 57 | 309.00 |
| TD541 | 47 | 62 | 309.00 |
| TD542 | 50 | 62 | 309.00 |
| TD543 | 52 | 67 | 483.00 |
| TD544 | 55 | 67 | 528.00 |
| TD545 | 60 | 73 | 652.00 |



| Model No. | Size" | Length" | Price /Each |
|--|-------|---------|-------------|
| 1/4" DRIVE INDIVIDUAL SOCKET, 6 POINT | | | |
| TD546 | 3/16 | 9/16 | 75.30 |
| TD547 | 7/32 | 9/16 | 75.30 |
| TD548 | 1/4 | 5/8 | 75.50 |
| TD549 | 9/32 | 5/8 | 75.50 |
| TD550 | 5/16 | 5/8 | 75.50 |
| TD551 | 11/32 | 5/8 | 76.20 |
| TD552 | 3/8 | 11/16 | 77.60 |
| TD553 | 7/16 | 11/16 | 79.90 |
| TD554 | 1/2 | 13/16 | 81.40 |
| TD555 | 9/16 | 7/8 | 85.90 |

| | | | |
|--|--------|--------|--------|
| 1/2" DRIVE INDIVIDUAL SOCKET, 6 POINT | | | |
| TJZ875 | 5/16 | 1 3/16 | 69.90 |
| TJZ876 | 3/8 | 1 3/16 | 70.70 |
| TJZ877 | 7/16 | 1 3/16 | 71.20 |
| TJZ878 | 1/2 | 1 3/16 | 72.40 |
| TJZ879 | 9/16 | 1 3/16 | 73.50 |
| TJZ880 | 19/32 | 1 3/16 | 74.50 |
| TJZ881 | 5/8 | 1 7/16 | 79.10 |
| TJZ882 | 11/16 | 1 7/16 | 81.90 |
| TJZ883 | 3/4 | 1 7/16 | 86.10 |
| TJZ884 | 25/32 | 1 7/16 | 97.90 |
| TJZ885 | 13/16 | 1 7/16 | 97.90 |
| TJZ886 | 7/8 | 1 1/2 | 114.00 |
| TJZ887 | 15/16 | 1 1/2 | 114.00 |
| TJZ888 | 1 | 1 1/2 | 130.00 |
| TJZ889 | 1-1/16 | 1 1/2 | 140.00 |
| TJZ890 | 1-1/8 | 1 5/8 | 144.00 |
| TJZ891 | 1-1/4 | 1 5/8 | 169.00 |

| | | | |
|--|---------|--------|--------|
| 3/4" DRIVE INDIVIDUAL SOCKET, 6 POINT | | | |
| TJZ892 | 1-5/16 | 2 | 260.00 |
| TJZ893 | 1-3/8 | 2 | 260.00 |
| TJZ894 | 1-7/16 | 2 | 271.00 |
| TJZ895 | 1-1/2 | 2 1/16 | 264.00 |
| TJZ896 | 1-9/16 | 2 1/4 | 306.00 |
| TJZ897 | 1-5/8 | 2 1/4 | 306.00 |
| TJZ898 | 1-11/16 | 2 1/4 | 306.00 |
| TJZ899 | 1-3/4 | 2 9/16 | 306.00 |
| TJZ900 | 1-13/16 | 2 9/16 | 309.00 |
| TJZ901 | 1-7/8 | 2 9/16 | 309.00 |
| TJZ902 | 2 | 2 9/16 | 320.00 |

RATCHET WRENCHES

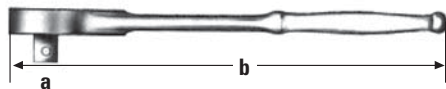

| Model No. | a" | b" | Wt. lbs. | Price/Each |
|-----------|-----|----|----------|------------|
| TD491 | 1/4 | 5 | 0.19 | 763.00 |
| TD492 | 1/2 | 10 | 1.24 | 381.00 |
| TD493 | 3/4 | 18 | 3.96 | 794.00 |

See pages
252 & 253 for
Grounding Clamps



NON-SPARKING, NON-MAGNETIC TOOLS



11-PC. TOOL KITS

Non-sparking, non-magnetic, corrosion-resistant tool kit.

Model No. TP519

Mfg. No. M-48

Price/Each \$1379.00



INCLUDES:

| Model No. | Mfg. No. | Description |
|-----------|----------|---|
| TP453 | P-31 | 8" Combination Slip-Joint Pliers |
| TD466 | B-399 | Shoe-Handle Scratch Brush |
| TX710 | K-21 | Putty Knife – Stiff Blade |
| TD486 | K-1 | Knife with Straight Blade |
| TP455 | P-39 | Tongue and Groove Pliers, 6 Positions |
| TD618 | S-1099 | Phillips Screwdriver No. 2 |
| BB514 | H-20FG | Curved-Claw Nail Hammer, Smooth Striking Face |
| TX679 | W-70 | 6" Adjustable Wrench |
| TX681 | W-72 | 10" Adjustable Wrench |
| TX685 | W-211 | 10" Adjustable Pipe Wrench |
| TD614 | S-49 | Standard Screwdriver 5/16" Tip, 6" Blade |

6-PC. TOOL KITS

Non-sparking, non-magnetic, corrosion-resistant tool kit.

Model No. TP518

Mfg. No. M-47

Price/Each \$665.00



INCLUDES:

| Model No. | Mfg. No. | Description |
|-----------|----------|--|
| TD613 | S-48 | Standard Screwdriver - 5/16" Tip, 3" Blade |
| TP452 | P-30 | 6 1/2" Combination Plier |
| TX680 | W-71 | Adjustable Wrench 8" |
| TD618 | S-1099 | Phillips Screwdriver No. 2 |
| TP455 | P-39 | Tongue and Groove Pliers, 6 Positions |
| TP415 | CJ-1-ST | 9" Hammer/Crate Opener |

17-PC. HAZMAT TOOL KITS

Non-sparking, non-magnetic, corrosion-resistant hazmat tool kit.

Model No. TP521

Mfg. No. M-51

Price/Each \$2459.00



INCLUDES:

| Model No. | Mfg. No. | Description |
|-----------|----------|--|
| TD466 | B-399 | Shoe Handle Brush |
| TP415 | CJ-1-ST | 9" Crate Opener |
| BB514 | H-20FG | 16 oz Claw Hammer w/Fiberglass Handle |
| TD485 | K-5 | Common Knife 5 3/4" Blade, 10 3/4" OAL |
| TX710 | K-21 | Putty Knife (stiff) 1 1/4" x 3 9/16" Blade |
| TP456 | P-312 | 12" Groove Joint Pliers |
| TP457 | P-326 | 7" Long Nose Pliers with Cutters |
| TP453 | P-31 | 8" Combination Pliers |
| TP477 | S-11G | Deck Scraper, 1 1/2" Blade x 15" Long |
| TP474 | S-40 | Spray Booth Scraper, 3" Blade x 9 1/4" lo |
| TD614 | S-49 | Standard Screwdriver - 5/16" Tip, 6" Blade |
| TD619 | S-1100 | # 3 Phillips Screwdriver |
| TP459 | S-1144 | 12" Tin Snaps |
| TX680 | W-71 | 8" Adjustable Wrench |
| TX682 | W-73 | 12" Adjustable Wrench |
| UQ916 | W-212AL | 14" Pipe Wrench (Aluminum) |
| UQ924 | W-56 | 12" Bung Wrench (Fits 3/4" x 2") |

16-PC. TOOL KITS

Non-sparking, non-magnetic, corrosion-resistant tool kit.

Model No. TP520

Mfg. No. M-49

Price/Each \$1880.00



INCLUDES:

| Model No. | Mfg. No. | Description |
|-----------|----------|--|
| TLZ293 | W-3109 | Double End Box Wrench – 5/16" x 3/8" |
| TLZ294 | W-3120 | Double End Box Wrench – 7/16" x 1/2" |
| TLZ295 | W-3150 | Double End Box Wrench – 9/16" x 5/8" |
| TLZ296 | W-3180 | Double End Box Wrench – 3/4" x 7/8" |
| TD618 | S-1099 | # 2 Phillips Screwdriver |
| TD614 | S-49 | Standard Screwdriver 5/16" tip, 6" blade |
| TX681 | W-72 | 10" Adjustable Wrench |
| TP452 | P-30 | 6 1/2" Combination Pliers |
| TP453 | P-31 | 8" Combination Pliers |
| TP455 | P-39 | 10" Groove Joint Pliers |
| TD486 | K-1 | Common Knife 3 1/8" Blade, 6 3/4" OAL |
| TX710 | K-21 | Putty Knife (Stiff) 1 1/4" x 3 9/16" |
| BB514 | H-20FG | Claw Hammer with Fiberglass Handle |
| TX686 | W-212 | 14" Adjustable Pipe Wrench |
| TD466 | B-399 | Shoe Handle Brush |
| TP479 | S-10G | Deck Scraper |

HORIZONTAL CELL HOLDERS

- Designed for cell phone, BlackBerry®-style mobile device, or larger iPod®, or iPhone® 4 or 5
- Includes ear-bud pocket and sleeve for business or credit cards
- Belt clip swivels to accommodate wearing on left or right side
- Dimensions: 5" L x 5" H

Model No. TEP219
Price/Each \$14.90



4-WAY LINEMAN TOOL POUCHES

- Made for pliers, screwdriver, ruler, adjustable wrenches and knife snap
- Pliers do not protrude from this pouch
- Bottom is vented to prevent collection of dirt
- Slotted to fit belt up to 2" wide
- Double backed and riveted
- Top grain leather
- Dimensions: 9 1/2" L x 7" H

Model No. TBN205
Price/Each \$43.50



UTILITY POUCHES

- Made of full grain leather
- Holds a knife, pencil, felt marker and other miscellaneous tools
- Excellent for warehousing and utility use
- Dimensions: 4 3/4" L x 11.75" H

Model No. TP214
Price/Each \$13.50



TRADESMAN PRO™ CELL PHONE HOLDERS

- Magnetic flap closure
- Metal clip for attached to belts up to 2" (51 mm) wide
- Constructed of 1680d ballistic weave
- Fits Samsung Galaxy S3®, S4®, S5®, Apple iPhone® 4, 5 & 6 and other similar sized phones
- Overall dimensions: 3 1/4" L x 1 1/2" W x 5 7/8" H
- Colour: Black
- Material: Ballistic weave

Model No. TUB329
Price/Each \$36.20



MULTI-PURPOSE TOOL HOLDERS

- Four pockets made of ballistic nylon
- Versatile 3-way attachment for pants, web suspenders, work aprons, etc.
- Securely holds small tools or accessories like pliers, mini flashlights, screwdrivers, etc.
- Dimensions: 5 1/4" L x 8 1/2" H

Model No. WI957
Price/Each \$14.90



TOOL POUCHES

- Made of full grain leather
- Designed to fit assorted utility items: pens, markers, tape, utility knife, etc.
- 2" wide belt slots
- Rivet reinforced
- Dimensions: 3 3/4" L x 11" H

Model No. TSW497
Price/Each \$14.50



BLACKBERRY® HOLDERS

- Designed for PDA, BlackBerry®-style mobile device, or iPhone®
- Includes ear-bud pocket and sleeves for business cards, credit cards, pens or touch-screen stylus
- Belt clip swivels to accommodate wearing on left or right side
- Magnetic shut off feature
- Dimensions: 3 1/2" L x 4 3/4" H

Model No. TEP218
Price/Each \$15.90



LARGE TAPE HOLDERS

- Made of top grain leather
- Designed to fit up to 30" tapes
- All rivet construction
- Dimensions: 6 3/4" L x 4 1/2" H

Model No. TBN166
Price/Each \$9.40



UTILITY KNIFE, PEN/ PENCIL HOLDERS

- Made of full grain leather
- Designed to fit pen/pencil and utility knife
- Comes with quick release snap belt loop
- Dimensions: 7 3/4" L x 2 3/4" H

Model No. TBN197
Price/Each \$11.90



MULTI POCKET TOOL & PHONE HOLDERS

- Attached to belt with snap closure or wide padded flap
- Four pockets and one padded pocket with elastic binding sized to fit most compact cell phones
- Detachable electrical tape sling
- Dimensions: 6" L x 11" H

Model No. TJZ972
Price/Each \$17.90



UTILITY KNIFE HOLDERS

- Made of polyester fabric
- Designed for utility and "lock-back"-style knives, pliers and snips
- Sleeves for pens, markers, carpenter's pencils, with integral measuring tape clip
- Easily snaps on to belts up to 2" wide

Model No. TEP509
Price/Each \$11.90



TAPE MEASURE HOLDERS

- Holds most tape measures with belt clips
- Rust-resistant metal clip riveted for strength
- Exceptional resistance to abrasion, punctures, and tearing
- Overall dimensions: 4 1/8" L x 1/4" W x 3 3/4" H
- Colour: Black
- Material: Ballistic nylon

Model No. TBS873
Price/Each \$15.10



TOOLS STORAGE

CORDLESS DRILL HOLSTERS

- Made of polyester fabric
- Holds most brands of T-handle drills
- Multiple outer pockets and sleeves for complete bit organization
- Elastic sleeve to hold bits, sockets, etc.
- Safety strap with quick-release buckle
- Hook and loop backing to keep strap back when not in use
- Holster is angled for better balance
- Fits belts to 2 3/4" wide

Model No. TEP222
Price/Each \$20.90



IMPACT DRIVER HOLSTERS

- Made of polyester fabric
- Designed for smaller 10.8 V - 18 V cordless impact drivers
- Adjustable strap and quick-release buckle holds driver securely in place
- Elastic sleeve to hold bits, sockets, etc.
- Hook and loop backing to keep strap back when not in use
- Holster is angled for better balance
- Fits belts to 2 3/4" wide

Model No. TEP221
Price/Each \$15.90



CORDLESS DRILL HOOKS

- Conveniently holds most cordless drills
- Ball-capped hook safely holds your drill
- Hook storable in a closed position when not in use
- Elastic webbing sleeve and pockets for bits and extensions
- Extra padding for comfort
- Fits belts to 2 3/4" wide

Model No. TEP508
Price/Each \$11.90



STEEL LOOP HAMMER HOLDERS

- Made of top grain leather
- Cradle design eliminates hammer pivoting
- Fits belts up to 2 3/4" wide
- Dimensions: 3 3/4" L x 7 1/2" H

Model No. TN237
Price/Each \$5.40



PLIERS POUCHES

- Made of heavy top grain leather
- Fits almost all pliers
- Dimensions: 8 1/4" L x 2 3/4" H

Model No. TN243
Price/Each \$9.00



SCISSORS & CABLE-SPLICER'S KNIFE HOLDERS

- Leather construction
- Riveted and stitched for extra durability
- Slotted belt connection
- Fits belts up to 2 1/4" wide
- Dimensions: 2" L x 7 1/4" H

Model No. TBS844
Price/Each \$16.90



PLIERS POUCHES

- Made of heavy top grain leather
- Holds a variety of pliers and miscellaneous tools
- Fits belts up to 2 1/4" wide
- Dimensions: 9" L x 3 1/4" H

Model No. TBN201
Price/Each \$9.50



LINEMAN'S KNIFE HOLDERS

- Leather construction
- Riveted to assure long life
- Slotted belt connection
- Fits belts up to 2" wide
- Dimensions: 3 1/2" x 9 3/8"

Model No. TBS831
Price/Each \$17.10



KNIFE HOLDERS

- Leather construction
- Corners riveted and stitched for extra durability
- Slotted belt connection
- Fits belts up to 2 1/2" wide
- Dimensions: 2 5/8" x 8 1/4"

Model No. TBS842
Price/Each \$19.80



PLIERS HOLDERS – OPEN BOTTOM

- Leather construction
- Long-nose pliers may protrude through opening at bottom
- Riveted to assure long life
- Slotted belt connection
- Fits belts up to 2" wide



Model No. TBT465

- Holds 6" or 7" long-nose or diagonal-cutting pliers
 - Dimensions: 3 1/2" x 8 1/2"
- Price/Each \$34.60

Model No. TBT466

- Holds 8" or 9" long-nose or diagonal-cutting pliers
 - Dimensions: 3 3/4" L x 11" H
- Price/Each \$44.50



UTILITY KNIFE & PLIERS HOLDERS

- Made of heavy top grain leather
- Fits most standard utility style trim knives and most pliers
- All rivet construction
- Dimensions: 8 1/2" L x 2 1/2" H

Model No. TN244
Price/Each \$6.50



TOOL BELTS

1 1/2" INDUSTRIAL BELTS

- Made of top grain leather
- 1 1/2" width with heavy roller buckle
- One size fits all

Model No. TN233 Price/Each \$18.90



2" INDUSTRIAL BELTS

- Made of top grain leather
- 2" width, with heavy-duty roller buckle
- One size fits all

Model No. TN234 Price/Each \$22.90



2" DOUBLE TONGUE BELTS

- Made of top grain leather
- 2" width with heavy-duty double tongue roller buckle
- One size fits all

Model No. TP207 Price/Each \$22.50



5" WIDE PADDED COMFORT BELTS

- Heavy-duty double layer lightweight fabric will not rot, crack, harden or mildew
- 2" double tongue metal roller buckle
- Foam padding
- Grip-Strip™ fastening system holds pouches securely in place
- Fits waist sizes 29"-46"

Model No. TBN140 Price/Each \$37.50



2" WEB WORK BELTS

- Heavy-duty poly web
- Quick-release buckle
- Fits waist sizes 29" to 46"

Model No. TAW990 Price/Each \$11.50



TOOL BELTS

A. LIGHTWEIGHT TOOL BELTS

- Leather fabrication
- Designed to carry lightweight tool pouches

B. HEAVY-DUTY EMBOSSED TOOL BELTS

- Strong, heavy-duty leather
- Equipped with a double-tongue buckle

C. LIGHTWEIGHT UTILITY BELTS

- Strong, lightweight, synthetic-web
- Quickly adjusts for waist sizes through 52"
- Accepts tunnel-loop and slotted pouches and holders
- Tough, molded, non-metallic, slide-action buckle provides single-handed, quick release and adjustment

D. GENERAL-PURPOSE BELTS

- Strong, heavy-duty leather
- Removable single-tongue buckle held by two heavy-duty snaps

A.



C.



B.



D.



KLEIN TOOLS
For Professionals... Since 1857™

| | Model No. | Colour | Size | Belt Width" | Wt. lbs. | Price /Each |
|----|-----------|--------|-------------------|-------------|----------|-------------|
| A. | TBS851 | Black | 33"-45" | 1 | 0.30 | 21.30 |
| B. | TBT511 | Tan | 32"-40" | 2 | 0.63 | 49.30 |
| | TBS856 | Tan | 36"-44" | 2 | 0.64 | 50.90 |
| | TBT510 | Tan | 40"-48" | 2 | 0.64 | 52.60 |
| | TBT512 | Tan | 44"-52" | 2 | 0.65 | 54.10 |
| C. | TBS852 | Blue | One Size Fits All | 2 | 0.20 | 16.10 |
| D. | TBT501 | Black | 32"-40" | 1 1/2 | 0.40 | 47.20 |
| | TBT500 | Black | 38"-46" | 1 1/2 | 0.45 | 49.20 |
| | TBT502 | Black | 46"-54" | 1 1/2 | 0.50 | 51.20 |

HEAVY-DUTY WORK SUSPENDERS

- Adjustable to fit all sizes
- Heavy-duty clips on front and rear
- 2" wide heavy-duty elastic straps
- Nylon stitched for durability

Model No. TP208 Black

Price/Each \$18.50

Model No. TBN236 Red

Price/Each \$18.50



PADDED CONSTRUCTION SUSPENDERS

- Designed to transfer weight from waist to shoulders
- Fully adjustable length, front and back to fit all sizes
- Heavy-duty padding for user comfort
- Heavy-duty nylon web for extra strength
- Convenient quick fastening system

Model No.

TBN243

Price/Each

\$42.00



For step ladders refer to pages 127 - 136



TOOLS STORAGE

FALLERS TOOL POUCHES

- Dimensions: 11.75" x 5.5"
- Made of durable split leather
- Material: Leather
- Colour: Tan
- No. of Pockets: 23
- Style: Multiple Tool Holder

Model No. TBN711
Price/Each \$19.90



11-POCKET PROFESSIONAL ELECTRICIAN'S POUCHES

- Double layer of rugged, lightweight nylon
- Two large main pockets, three smaller pockets
- Six large screwdriver holders, electrical tape chain and tool snap
- Metal clip holds all measuring tape sizes
- Dimensions: 8 1/2" L x 14 1/2" H

Model No. WI969
Price/Each \$56.90



8-POCKET ELECTRICIAN'S TOOL POUCHES

- Top grain leather
- One main deep pocket, six additional front and side pockets for screwdrivers, wrenches, etc.
- Fits belts up to 2 3/4" wide
- Leather hammer loop
- Leather holder fits up to 30" measuring tape
- Tape chain and metal tool clip
- Dimensions: 10 1/2" L x 11" H

Model No. TBN138
Price/Each \$48.90



4-POCKET TOOL POUCHES

- Leather fabrication
- Riveted and stitched for extra durability
- Speciality add-ons: Knife snap
- Slotted belt connection
- Fits belts up to 2" wide
- Dimensions: 8 1/2" L x 10 3/4" H

Model No. WK777
Price/Each \$38.30



8-POCKET EXTRA-CAPACITY TOOL POUCHES

- Leather fabrication
- Extra-capacity multi-purpose pouch
- Stitched and riveted
- Speciality add-ons: Knife snap & Leather Tape Thong
- Tunnel loop belt connection
- Fits belts up to 3" wide
- Dimensions: 8 1/2" L x 10 3/4" H

Model No. TGZ768
Price/Each \$207.00



ELECTRICIAN'S TOOL POUCHES

- Ballistic polyester fabrication – 1680D
- Two large main pockets, five small pockets
- Nylon/PP reinforced pouch bindings
- Heavy gauge 6-ply nylon stitching
- Electrical tape chain and tool spring clip
- Screened nickel-plated steel storm drains
- Metal clip holds all measuring tape sizes
- Nickel-plated steel rivets
- Dimensions: 12 1/2" L x 11" H

Model No. TEP008
Price/Each \$57.20



MAINTENANCE TOOL POUCHES

- Double zipper that keeps the tools in place and accommodate longer tools
- Push-button that keeps the cover away from the tools access
- Several compartments can store a wide variety of tools
- Carabineer and tape holder
- Belt clip that fits belts up to 2 3/4" wide
- Dimensions: 6" L x 9 3/4" H

Model No. TEP259
Price/Each \$22.90



21-POCKET ZIPPERED PROFESSIONAL ELECTRICIAN'S TOOL POUCHES

- Double layer of rugged, lightweight 600D polyester fabric
- Zippered top flap to prevent spillage of tools when not in use
- Ergonomic rubber handle and padded shoulder strap design for easy storage and the ideal way to carry loaded tool pouch
- Zippered back pocket for 8" x 5" writing pad
- Outside pocket to hold cell phone holder and three outside large screwdriver holders
- Dimensions: 11 1/2" L x 16" H

Model No. TBN126
Price/Each \$69.90



6-POCKET TOOL POUCHES

- Leather fabrication
- Riveted to assure long life
- Speciality add-ons: Knife snap
- Dimensions: 7" L x 10" H

Model No. TBS816
• Slotted belt connection
• Fits belts up to 2" wide
Price/Each \$74.70

Model No. TBT486
• Tunnel loop belt connection
• Fits belts up to 2 1/2" wide
Price/Each \$78.90



10-POCKET TOOL POUCHES

- Leather fabrication
- Riveted and stitched
- Speciality add-ons: Knife snap
- Slotted belt connection
- Fits belts up to 2" wide
- Dimensions: 10" L x 10" H

Model No. TBS833
Price/Each \$106.00



5-POCKET TOOL POUCHES

- Leather fabrication
- Curved to fit the hip for added comfort
- Riveted to assure long life
- Speciality add-ons: Knife snap

Model No. TBS815
Price/Each \$59.20



3-WAY LINEMAN TOOL POUCHES

- Made of top grain leather
- Bottom is vented to prevent collection of dirt
- Slotted to fit belt up to 2" wide
- Double backed and riveted
- Dimensions: 9 1/4" L x 6 1/4" H

Model No. TN246
Price/Each \$31.90

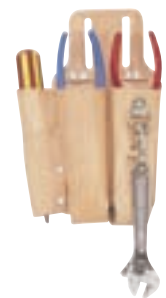

6-POCKET NAIL/SCREW & TOOL POUCHES

- Leather fabrication
- Heavy hammer-loops on both sides
- Riveted and stitched for extra durability
- Speciality add-ons:
 - Two hammer loops
 - Tunnel loop belt connection
- Fits belts up to 3" wide
- Dimensions: 11" L x 11 3/4" H

Model No. TBS964
Price/Each \$71.20



KLEIN TOOLS
For Professionals... Since 1857™

11-POCKET NAIL & TOOL BAGS

- Constructed out of durable, lightweight polyester fabric and ballistic binding
- 2 main pockets for nails or tools
- 6 smaller pockets - for hand tools, pencils, or nail sets
- 2 additional upper pockets
- Contains a holder for a pry bar or a combination square
- Also includes steel hammer loops
- Fits on belts up to 2 3/4" wide
- Dimensions: 13" L x 3" W x 13" H
- Colour: Black
- Material: Polyester/ballistic

Model No. TBN045
Price/Each \$34.90



3-POCKET UTILITY POUCHES

- Leather fabrication
- Features 1" reinforced gusset
- Has 2" outside pockets
- Riveted and stitched for extra durability
- Tunnel loop belt connection
- Fits belts up to 1" wide
- Dimensions: 5 1/4" L x 7" H

Model No. TBS825
Price/Each \$48.90



KLEIN TOOLS
For Professionals... Since 1857™

10-POCKET TOOL POUCHES

- Leather fabrication
- Riveted throughout to assure long life
- Ten separate compartments
- Slotted-leather tape thong (allows easy removal of 1" I.D. tape rolls)
- Speciality add-ons:
 - Leather tape thong
 - Slotted belt connection
- Fits belts up to 1 3/4" wide
- Dimensions: 6" L x 8 3/4" H

Model No. TBS846
Price/Each \$77.60



KLEIN TOOLS
For Professionals... Since 1857™

16-POCKET APRONS

- Five pockets for larger tools and cell phone
- Eight small pockets
- 3-compartment chest pocket
- Adjustable neck strap and belt with quick-release buckle
- Dual hammer loops
- Dimensions: 15" L x 10 3/4" H

Model No. TEP028
Price/Each \$41.30



11-POCKET TOOL POUCHES

- Leather fabrication
- Soft, pliable, and moisture-resistant to retain flexibility even after being wet and dried
- Riveted and stitched
- Stainless steel power-return tape holder clip (accommodates from 8' to 30' tapes)
- Heavy-duty chain tape thong securely fastened with a rivet
- Speciality add-ons:
 - Knife snap, Chain tape thong, Metal tape measure holder
- Slotted belt connection
- Fits belts up to 2 3/4" wide
- Dimensions: 10" L x 10 1/2" H

Model No. TBS835
Price/Each \$175.00



KLEIN TOOLS
For Professionals... Since 1857™

2-POCKET CANVAS WORK APRONS

- 6-8 oz. canvas fabrication
- Two large nail pockets
- Dimensions: 15 3/4" L x 10 3/4" H

Model No. TN216
Price/Each \$4.60



12-POCKET CANVAS BIB APRONS

- Canvas fabrication
- Five large pockets
- Two nylon hammer loops
- Dimensions: 15" L x 10 3/4" H

Model No. TN215
Price/Each \$14.90



23-POCKET, 5-PIECE COMFORTLIFT™ COMBO SYSTEMS

- Made of polyester fabric and ballistic binding
- Completely adjustable, padded suspenders engineered to hold and distribute weight comfortably evenly without strain on lower back and hips
- Easy carry handle design for simple adjustments and easy storage without spilling contents
- Newly designed Sta-Open main pockets are tapered for faster access to contents
- Custom pocket for combination square
- 2" wide web belt with double tongue steel roller buckle
- Fits waist sizes 29"-46"

Model No. TBN044
Price/Each \$124.00



13-POCKET WAIST APRONS

- Five pockets for larger tools and cell phone
- Eight pockets for pens, pencils, and small tools
- Dual hammer loops
- Dimensions: 20" L x 12" H

Model No. TEP029
Price/Each \$33.90



JOURNEYMAN CARPENTER APRONS

- Made of heavy split leather
- Steel hammer holder
- Centre pocket for tape or other tool
- Heavy leather belt with roller buckle
- Reinforced at all stress points
- Dimensions: 23 1/2" L x 12 1/2" H

Model No. TN221
Price/Each \$79.90



TOOLS STORAGE

75-POCKET TOOL BACKPACKS

- Made of DuPont Cordura Plus fabric
- Enough interior panels to hold a multitude of tools including: 14-pc. wrench sets, electric drills, extension cords, pliers, screwdrivers and much more
- 7" x 5" multi-compartment plastic tray included
- Dimensions: 13" L x 17 1/2" W x 9" H

Model No. TBN248
Price/Each \$165.00



STANDARD NUT & BOLT BAGS

- Heavy-duty canvas duck
- Large main pocket and two tapered drift pin holders
- Canvas loop accepts belts up to 4" wide
- Dimensions: 12" L x 9" H

Model No. TBN273
Price/Each \$28.00



HEAVY-DUTY CANVAS BUCKETS

- Made with top grade heavy-duty canvas material and high strength top ring
- Polypropylene (back-braided) rope handle, reinforced with leather and grommet eyelets where it is spliced around top ring
- Dimensions: 11" Dia. x 16" H

Model No. TP204
Plastic bottom
Price/Each \$88.90



Model No. WL001
Leather bottom
Price/Each \$99.90



ARSENAL LEATHER BOTTOM CANVAS TOOL BUCKETS

- High wall, heavy-duty construction with leather reinforced base
- Molded plastic top ring
- Interior pocket
- Size: 12.5" dia. x 17" H
- Maximum safe working capacity: 150 lbs.
- Available with safety tops to prevent tools and equipment from falling when hoisting them to an at-heights job site

SEE106



| Model No. | Mfg. No. | Description | Price/Each |
|-----------|----------|---|------------|
| SEE105 | 14430 | Bucket w/Rope Handle | 174.00 |
| SEE106 | 14440 | Bucket w/Rope Handle and Swivel Snap Hook | 192.00 |
| SEE109 | 14438 | Safety Top for 12.5" dia. | 53.90 |

48-POCKET BUCKET BUDDY

- 14 double row pockets inside and 34 triple row pockets outside organize a wide range of tools and accessories
- Security pocket with hook and loop closure
- Drill pocket with hook and loop handle strap
- Designed to fit most 3 1/2 - 5 gallon buckets
- Measuring tape strap and key clip included

Model No. VQ267
Price/Each \$28.00



17-POCKET ELECTRICAL & MAINTENANCE TOOL POUCHES

- Heavy-duty top grain leather
- Box-shaped design prevents tipping
- Large divided main pocket for extra tool capacity
- Leather reinforced carrying handle and electrical tape chain
- Dimensions: 8 1/2" L x 16" H

Model No. VE823
Price/Each \$179.00



25-POCKET TOOL ROLL-UPS

- Ballistic poly fabrication - 1680D
- Rolls up for easy stowing
- Carry handle for easy transport
- Heavy gauge 6-ply nylon stitching
- Socket pockets hold 3/8" or 1/4" sockets
- Product open dimensions: 27" L x 14.5" W

Model No. TEP032
Price/Each \$36.50



ARSENAL® 5518 TOPPED TOOL POUCHES

- Top cover flap with hook and loop closure
- Four nickel-plated D-rings for tool lanyard attachment
- Patented Storm Drains™
- Abrasion-resistant PVC-reinforced pouch bases
- Maximum safe working capacity: 33 lbs.
- Dimensions: 11" L x 4.5" W x 11" H
- Colour: Grey
- Material: Ballistic nylon

Model No. TEP521
Mfg. No. 13642
Price/Each \$99.90



22-POCKET BIGMOUTH® BAGS

- 12-multi-use pockets inside and outside organize tools and accessories
- Opens wide for easy access to bag's contents
- Padded reinforced web carrying handles and adjustable shoulder strap
- Dimensions: 16" L x 8 1/2" W x 10" H

Model No. BB391
Price/Each \$45.30



ALL-PURPOSE GEAR BAGS

- All-purpose gear bag perfect for carrying air hoses, kneepads, power tools, extension cords, etc.
- Outside pockets to organize small tools or accessories
- Abrasion resistant rubber feet
- Reinforced padded carrying handles
- Dimensions: 24" L x 12" W x 12" H

Model No. TEP215
Price/Each \$46.50



WATER RESISTANT DUFFEL BAGS

- Made of water resistant tarpaulin material with 1000D polyester mesh
- Heavy-duty YKK zippers with flap for moisture protection
- Shoulder strap configured to carry as duffel or backpack
- Interior mesh pocket under flap

TEP504



| Model No. | Mfg. No. | Dimensions L" x W" x H" | Interior Size (cu. in.) | Price /Each |
|-----------|----------|-------------------------|-------------------------|-------------|
| TEP504 | GB5030S | 24 x 15 x 15 | 4395 | 193.00 |
| TEP505 | GB5030M | 28 x 17 x 17 | 5549 | 222.00 |
| TEP506 | GB5030L | 32 x 19 x 19 | 9460 | 251.00 |

ARSENAL® 5020 DUFFEL BAGS

- Heavy duty ribbed straps top and side
- Removable, adjustable shoulder strap and strap grabber
- Two end zipper pockets
- Colour: Red
- Material: Nylon



| Model No. | Mfg. No. | Dimensions L" x W" x H" | Bag Capacity L | Price /Each |
|-----------|----------|-------------------------|----------------|-------------|
| TY0337 | 13020 | 23 x 12 x 12 | 44 | 58.40 |
| TY0338 | 13021 | 29 x 13 x 13 | 63 | 70.80 |
| TY0339 | 13022 | 35 x 14 x 14 | 104 | 88.50 |

TRADESMAN PRO™ ELECTRICIAN'S BACKPACK ORGANIZERS

- 39 pockets for tons of tool storage
- Orange interior for easy tool visibility
- Wide opening fits power drills, meters, flashlights etc.
- Tough, durable bottom protects from harsh elements
- Large front pocket easily fits cables, small parts and tools
- 1680D ballistic weave for durability
- Dimensions: 14" L x 7" W x 18" H
- Colour: Black
- Material: Ballistic

Model No. TYO472
Price/Each \$165.00



23-POCKET LARGE ELECTRICAL & MAINTENANCE TOOL CARRIERS

- 11" x 6" multi-compartment plastic tray included that slides securely into bottom of tool carrier to organize small parts
- 16 multi-use outside pockets and 7 inside pockets to organize a wide range of tools and accessories
- Box shaped design prevents tipping over
- Extra padded carrying handle and adjustable shoulder strap
- Electrical tape strap
- Dimensions: 11" L x 10" W x 19" H

Model No. TBN256
Price/Each \$72.90



OPEN TOP 20" SOFT SIDE TOOL BOXES

- Removable and adjustable metal frame partition slides securely into place to customize tool box to your storage needs
- Plastic reinforced internal pocket for utility knife or other tools
- Sturdy metal handle bar with molded foam grip for easy carrying
- Wide-open space below handles for easy access to tool carrier's main compartment
- 27 multi-use pockets and six webbing loops to organize a wide range of tools and accessories
- Adjustable, padded shoulder strap
- Dimensions: 20" L x 11" W x 11" H

Model No. TEP217
Price/Each \$99.90



OPEN TOP 14" SOFT SIDE TOOL BOXES

- Removable and adjustable metal frame partition slides securely into place to customize tool box to your storage needs
- Plastic reinforced internal pocket for utility knife or other tools
- Sturdy metal handle bar with molded foam grip for easy carrying
- Wide open space below handle for easy access to tool carrier's main compartment
- 21 multi-use pockets and 10 webbing loops to organize a wide range of tools and accessories
- Adjustable, padded shoulder strap
- Dimensions: 14" L x 11" W x 11" H

Model No. TJZ969
Price/Each \$80.50



TECHGEAR™ POWER DISTRIBUTION TOOL BAGS

- Removable surge protector can be mounted on the outside or on the inside of bag
- 10 multi-use pockets inside and 24 outside
- Padded, adjustable shoulder strap for easy carrying
- Distributes power to 4 plug outlets for multiple electrical device connections
- Colour: Black
- Material: Polyester

Model No. TEQ486
Price/Each \$105.00



TECH GEAR™ LED LIGHTED 14" BIGMOUTH® TOOL BAGS

- Built-in LED light can be easily directed at work area or into tool bag to help identify tools and parts
- Three levels of light output allows adjustment for wide area illumination or close-up work
- Bigmouth™ design gives easy access to tools and accessories
- 11 multi-use pockets inside and 18 outside to help better organize your tools
- Padded web carrying handles and adjustable shoulder strap
- Base pad feet to help reduce wear and abrasion
- Powered by two AAA batteries (batteries included)
- Dimensions: 14" L x 8" W x 11 1/2" H

Model No. TEP511
Price/Each \$79.80



TECH GEAR™ LED LIGHTED HANDLE 18" OPEN TOP TOOL CARRIERS

- LED light handle can be easily directed at work area or into tool carrier to help identify tools and parts
- Three levels of light output allows adjustment of wide area illumination or close-up work
- Ergonomic handle design helps reduce stress on hand and wrist
- Large open compartment provides easy access to power tools and accessories
- 47 multi-use pockets and 10 webbing loops to help organize your favorite hand tools
- Padded, adjustable shoulder strap for easy carrying
- Base pad feet to help reduce wear and abrasion
- Powered by two AAA batteries (batteries included)
- Dimensions: 18" L x 9" W x 11 1/4" H

Model No. TEP512
Price/Each \$119.00



TECH GEAR™ LED LIGHTED 18" MEGAMOUTH™ TOOL BAGS

- Built-in LED light can be easily directed at work area or into tool bag to help identify tools and parts
- Three levels of light output allows adjustment for wide area illumination or close-up work
- Megamouth™ design for easy access to main compartment has internal metal frame to help keep bag open
- 19 multi-use pockets inside and 26 outside allows for storage of your favorite tools, parts and accessories
- Padded shoulder strap for comfortable and convenient no-hands transport
- Base pad feet to help reduce wear and abrasion
- Powered by two AAA batteries (batteries included)
- Dimensions: 18" L x 9" W x 13" H

Model No. TEP513
Price/Each \$99.90



TECH GEAR™ LED LIGHTED HANDLE 18" DUAL COMPARTMENT TOOL CARRIERS

- LED light handle can be easily directed at work area or into carrier to help identify tools and parts
- Three levels of light output allows adjustment for wide area illumination or close-up work
- Features a compartment designed for power tools and another compartment designed with pockets for hand tools and accessories
- 42 multi-use pockets inside and 14 outside pockets to help organize a wide variety of hand tools
- 7" x 5 1/2" multi-compartment plastic tray included
- Ergonomic handle design helps reduce stress on hand and wrist
- Padded, adjustable shoulder strap for easy carrying
- Base pad feet to help reduce wear and abrasion
- Powered by two AAA batteries (batteries included)

Model No. TEP514
Price/Each \$179.00



TOOLS STORAGE

PLASTIC TOOL BOXES

- ABS plastic latches
- Heavy-duty polypropylene fabrication
- Removable inner trays
- Deep storage compartments
- Padlock eye for safe storage

aurora tools®

| Model No. | Dimensions | | | Features | Price /Each |
|-----------|------------|---------|----------|--|-------------|
| | W" | x D" | x H" | | |
| TLV082 | 15 | x 7 | x 5 1/2 | 1 Removable Inner Tray | 19.70 |
| TLV083 | 17 1/2 | x 9 1/2 | x 8 | 1 Removable Inner Tray | 29.35 |
| TLV084 | 17 1/2 | x 9 1/2 | x 8 | 1 Removable Inner Tray, 2 Parts Boxes, 1 Organizer | 34.85 |
| TLV085 | 22 | x 11 | x 10 1/2 | 1 Removable Inner Tray, 3 Organizers | 42.35 |
| TLV086 | 22 | x 11 | x 14 1/2 | 1 Removable Inner Tray, 3 Organizers, 2 Drawers | 70.00 |
| TLZ117 | 5 1/2 | x 5 1/2 | x 1 1/2 | Parts Box | 4.25 |



TLV082



TLV083



TLV084



TLV085



TLV086

UTILITY BOXES

- Heavy gauge steel construction
- Fully welded seams provide maximum strength
- Side handles facilitates transportation
- Diamond plate finish
- Black powder coat finish

aurora tools®

| Model No. | Dimensions | | | Wt. lbs. | Price /Each |
|-----------|------------|----------|------|----------|-------------|
| | W" | x D" | x H" | | |
| TEP498 | 31 | x 13 1/2 | x 10 | 15 | 94.45 |
| TEP499 | 45 | x 15 | x 15 | 35 | 205.00 |



TEP498

WATERLOO PORTABLE TOOL STORAGE SERIES

- Available in a choice of plastic and metal options
- Polyurethane portables with new design features provide additional strength



TEP471



TEP478



ATB100 PORTABLE TOOL BOXES

- Durable steel construction
- Heavy-plated latches
- Inner trays in regular hand boxes
- High gloss powder coat paint finish



TEP337



TEP338



TEP336



TEP339



TEP340



TEP516

aurora tools®

| Model No. | Description | Overall Dimensions | | | Wt. lbs. | Price /Each |
|-----------|---|--------------------|---------|---------|----------|-------------|
| | | L" | W" | H" | | |
| TEP336 | 21" Tool Box w/ Metal Tool Tray | 21 | x 8 3/4 | x 9 | 12 | 58.50 |
| TEP337 | 26" Tool Box w/ Metal Tool Tray | 26 | x 8 3/4 | x 9 | 15 | 75.95 |
| TEP338 | 20" Hip Roof Box w/ Metal Tool Tray | 20 | x 7 | x 8 | 8 | 48.80 |
| TEP339 | 21" Cantilever Tool Box | 21 | x 8 3/4 | x 12 | 16 | 94.95 |
| TEP340 | 21" 3-Drawer Chest | 21 | x 8 3/4 | x 12 | 20 | 89.95 |
| TEP516 | 16" Portable Tool Box w/Metal Tool Tray | 16 | x 6 | x 6 1/2 | 10 | 33.15 |

| Model No. | Mfg No. | Description | Dimensions | | | Price /Each |
|---------------------------|-----------|---------------------------------|------------|----------|----------|-------------|
| | | | W" | x D" | x H" | |
| PLASTIC TOOL BOXES | | | | | | |
| TEP471 | PP-2314BK | 3-Drawer Plastic Portable Chest | 23 | x 10 1/2 | x 13 1/2 | 73.10 |
| TEP473 | PP-2610BK | 26" Plastic Tool Box w/Tote | 26 | x 10 1/2 | x 10 | 33.30 |
| TEP474 | PP-2310BK | 23" Plastic Tool Box w/Tote | 23 | x 10 1/2 | x 10 | 29.70 |
| TEP475 | PP-2009BK | 20" Plastic Tool Box w/Tote | 20 | x 9 1/4 | x 9 | 22.90 |
| TEP476 | PP-1709BK | 17" Plastic Tool Box w/Tote | 17 | x 9 1/4 | x 9 | 18.50 |
| TEP477 | PP-1406BK | 14" Plastic Tool Box w/Tote | 14 | x 7 1/2 | x 6 1/4 | 11.30 |
| METAL TOOL BOXES | | | | | | |
| TEP478 | MP-2012BK | 20" 3-Drawer Portable Chest | 20 | x 9 | x 12 | 79.90 |

ROAD CHESTS

- Extra heavy gauge steel construction
- Drop front has neoprene seal to make it water and dust resistant
- Compound friction drawer slides
- Cushion feet pads for extra protection
- High gloss powder coat scratch resistant black paint



TEP500

aurora tools®

| Model No. | Dimensions | | | Wt. lbs. | Price /Each |
|-----------|------------|------|------|----------|-------------|
| | W" | x D" | x H" | | |
| TEP500 | 26 | x 18 | x 22 | 114 | 575.00 |
| TEP501 | 34 | x 18 | x 23 | 148 | 815.00 |

ATB300 TOOL BOXES

TEP331

- Double wall steel construction for added strength
- Full extension ball bearings slides on all drawers
- Extruded aluminum drawer handle trim
- Heavy-duty casters 5" x 2" (56" & 42") 5" x 1 1/4" (27")
- Gas struts are in the lid of 56" & 42" wide chest for ease of opening and closing
- Non-slip drawer liners
- High gloss powder coat scratch resistant paint



TEP312



TEP315



aurora tools

| Model No. | | | No. of Drawers | Dimensions L" x W" x H" | Drawer Capacity lbs. | Unit Capacity lbs. | Wt. lbs. | Price /Each |
|------------------|--------|--------|----------------|----------------------------|----------------------|--------------------|----------|-------------|
| Red | Blue | Black | | | | | | |
| CHEST | | | | | | | | |
| TEQ435 | TEQ436 | TEP312 | 4 | 26 x 12 x 14 1/2 | 75 | 375 | 41 | 237.00 |
| TEQ437 | TEQ438 | TEP314 | 6 | 26 x 18 x 19 | 75 | 675 | 75 | 348.00 |
| TEQ439 | TEQ440 | TEP316 | 10 | 41 x 18 x 19 | 120 | 1200 | 119 | 683.00 |
| TEQ441 | TEQ442 | TEP318 | 6 | 56 x 24 x 19 | 120 | 720 | 163 | 1155.00 |
| TOOL CART | | | | | | | | |
| TEQ443 | TEQ444 | TEP313 | 5 | 27 x 18 x 31 | 100 | 500 | 85 | 368.00 |
| TEQ445 | TEQ446 | TEP315 | 7 | 27 x 18 x 35 5/8 | 100 | 700 | 102 | 472.00 |
| TEQ447 | TEQ448 | TEP317 | 11 | 42 x 18 x 40 | 120 | 1320 | 175 | 1050.00 |
| TEQ449 | TEQ450 | TEP319 | 10 | 56 x 24 x 39 1/2 | 120 | 1200 | 320 | 1799.00 |

ACCESSORIES FOR ATB300 & ATB400 TOOL BOXES

| Model No. | | | Description | Dimensions L" x W" x H" | Wt. lbs. | Price /Each |
|-----------|--------|--------|----------------------|----------------------------|----------|-------------|
| Red | Blue | Black | | | | |
| TEQ471 | TEQ472 | TEP495 | 1-Shelf Side Cabinet | 14 x 18 x 33 1/2 | 43 | 255.00 |
| TEQ473 | TEQ474 | TEP496 | 2-Shelf Side Cabinet | 14 x 18 1/4 x 52 | 80 | 459.00 |
| TEQ475 | TEQ476 | TEP497 | 2-Shelf Side Cabinet | 15 x 24 x 51 | 66 | 535.00 |

UTILITY CARTS

- Heavy-duty steel construction
- Full extension ball bearing slides on all drawers
- High quality 4" swivel casters
- Drawer capacity: 100 lbs.
- Unit capacity: 550 lbs.
- High-gloss powder coat scratch-resistant black paint



TEP483

outilsaurora

| Model No. | No. of Drawers | Dimensions W" x D" x H" | | | | Wt. lbs. | Price /Each | |
|-----------|----------------|----------------------------|---|--------|---|----------|-------------|--------|
| TEP502 | 2 | 46 | x | 16 1/2 | x | 36 | 106 | 650.00 |
| TEP483 | 4 | 33 | x | 18 | x | 39 | 100 | 550.00 |

ATB400 TOOL BOXES

- Heavy-duty double wall steel construction for added strength
- Quadra level ball bearing slides on all drawers
- Heavy-duty reinforced bottom support rails for heavier loads
- Heavy-duty casters 5" x 2" with double layer ball bearings
- Full extension slides for easy reach inside
- Integrated latch security drawer system prevents drawers from accidentally opening
- Heavy-duty gas struts on top lid
- High-gloss powder coat scratch-resistant blue paint
- Includes non-slip drawer liners



TEP322



TEP323



aurora tools

| Model No. | | | No. of Drawers | Dimensions L" x W" x H" | Drawer Capacity lbs. | Unit Capacity lbs. | Wt. lbs. | Price /Each |
|-------------------|--------|--------|----------------|----------------------------|----------------------|--------------------|----------|-------------|
| Red | Blue | Black | | | | | | |
| CHESTS | | | | | | | | |
| TEQ451 | TEP320 | TEQ452 | 4 | 26 7/8 x 18 1/4 x 18 1/4 | 100 | 500 | 74 | 695.00 |
| TEQ453 | TEP322 | TEQ454 | 5 | 26 7/8 x 18 1/4 x 17 | 100 | 600 | 84 | 799.00 |
| TEQ455 | TEP324 | TEQ456 | 6 | 41 1/2 x 18 1/4 x 20 | 100 | 700 | 118 | 999.00 |
| TEQ457 | TEP326 | TEQ458 | 9 | 53 1/2 x 18 1/4 x 22 1/4 | 100 | 1000 | 173 | 1285.00 |
| TOOL CARTS | | | | | | | | |
| TEQ459 | TEP321 | TEQ460 | 5 | 28 7/8 x 18 7/8 x 31 3/8 | 100 | 600 | 111 | 760.00 |
| TEQ461 | TEP323 | TEQ462 | 7 | 28 7/8 x 18 7/8 x 36 5/8 | 100 | 800 | 135 | 935.00 |
| TEQ463 | TEP325 | TEQ464 | 14 | 43 3/8 x 18 7/8 x 37 3/4 | 120 | 1600 | 221 | 1350.00 |
| TEQ465 | TEP327 | TEQ466 | 13 | 55 7/16 x 18 7/8 x 37 1/2 | 120 | 2400 | 264 | 1998.00 |

WATERLOO SERIES HEAVY-DUTY TOOL STORAGE SERIES

- Ball-bearing slides provide 50-lb. drawer load rating
- Standard 4 1/2" x 1 1/2" casters provide 700-lb. unit load rating
- Keyed locks with internal lock bars
- 41" cabinet includes MDF work surface and full-width top drawer for long-tool storage
- Colour: Red



TEP411



| Model No. | Mfg No. | No. of Drawers | Dimensions W" x D" x H" | | | | Price /Each | |
|-----------------|------------|----------------|----------------------------|---|----|---|-------------|---------|
| CHESTS | | | | | | | | |
| TEP411 | WCH-266RD | 6 | 26 | x | 12 | x | 15 1/2 | 270.00 |
| TEP415 | WCH-265RD | 5 | 26 | x | 16 | x | 20 | 353.00 |
| TEP439 | WCH-418RD | 8 | 41 | x | 16 | x | 20 | 742.00 |
| CABINETS | | | | | | | | |
| TEP419 | WCA-265RD | 5 | 26 | x | 18 | x | 32 | 412.00 |
| TEP427 | WCA-266RD | 6 | 26 | x | 18 | x | 41 | 559.00 |
| TEP443 | WCA-411IRD | 11 | 41 | x | 18 | x | 37 1/2 | 1173.00 |



- Drawer slide type: Ball bearing
- Single slide drawer capacity: 100 lbs.
- Double slides drawer capacity: 200 lbs.
- Heavy duty steel construction
- High gloss powder coat finish resists scratches, stains and chemicals
- Full-width polished aluminum drawers
- Secure, tubular coded lock system
- High density foam drawer liners included
- Tool box shell gauge: 20 ga.
- Tool box drawer gauge: 18 ga.
- **Five-year warranty**

TEP595



TEP594



EXTREME TOOLS® EX STANDARD SERIES TOP TOOL CHEST

- 20" cabinet depth holds all your tools but fits in narrow spaces
- 2 side handle fit make moving your top chest easy
- Drawer dimensions:
 - (5) 23-3/8" W x 16-1/2" D x 2-1/4" H
 - (2) 11-3/4" W x 16-1/2" D x 2-1/4" H
 - (1) 11-3/4" W x 16-1/2" D x 7-3/4" H
- Weight: 143 lbs.

TEP609



EXTREME TOOLS® EX STANDARD SERIES ROLLING TOOL CABINET

- 20" cabinet depth holds all your tools but fits in narrow spaces
- (4) 5" x 2" casters supports up to 550 lbs. per caster
- 2 locking swivel casters and 2 rigid
- Chrome side handle fits on either end of roller cabinet
- Drawer dimensions:
 - (1) 37-3/8" W x 16-1/2" D x 5-1/4" H
 - (3) 23-3/8" W x 16-1/2" D x 2-1/4" H
 - (1) 23-3/8" W x 16-1/2" D x 5-1/4" H
 - (1) 23-3/8" W x 16-1/2" D x 8-1/4" H
 - (3) 11-3/4" W x 16-1/2" D x 2-1/4" H
 - (1) 11-3/4" W x 16-1/2" D x 5-1/4" H
 - (1) 11-3/4" W x 16-1/2" D x 8-1/4" H
- Weight: 235 lbs.

TEP611



| Model No. | Mfg. No. | No. of Drawers | Colour | Dimensions | | | Price /Each |
|-----------|------------|----------------|--------|------------|----------|----------|-------------|
| | | | | L" | x W" | x H" | |
| TEP608 | EX4108CHBK | 8 | Black | 41-1/2 | x 17-3/4 | x 21-3/8 | 1095.00 |
| TEP609 | EX4108CHBL | 8 | Blue | 41-1/2 | x 17-3/4 | x 21-3/8 | 1095.00 |

| Model No. | Mfg. No. | No. of Drawers | Colour | Dimensions | | | Price /Each |
|-----------|------------|----------------|--------|------------|------|----------|-------------|
| | | | | L" | x W" | x H" | |
| TEP610 | EX4111RCBK | 11 | Black | 41-1/2 | x 18 | x 40-1/2 | 1495.00 |
| TEP611 | EX4111RCBL | 11 | Blue | 41-1/2 | x 18 | x 40-1/2 | 1495.00 |

EXTREME TOOLS® EX STANDARD SERIES TOOL CABINET

- Side box can be mounted on either side of the tool box
- Drawers use quick-release, ball-bearing slides
- Drawer dimensions:
 - (3) 12-3/4" W x 16-1/2" D x 2-3/4" H
 - (2) 12-3/4" W x 16-1/2" D x 5-3/4" H
 - (1) 12-3/4" W x 16-1/2" D x 8-3/4" H
- Weight: 95 lbs.
- Tool box shell gauge: 20 ga.
- Tool box drawer gauge: 20 ga.

TEP596



EXTREME TOOLS® EX STANDARD SERIES TOOL SIDE CABINET

- Quick-release, ball bearing slides
- The (1) shelf can be adjusted to a height that suits your needs
- The cabinet and door can be rotated to fit the left or right side of your tool box
- (1) 5"x2" caster attaches under the side cabinet to provide extra support
- Drawer dimensions:
 - 11-3/4" W x 16-1/2" D x 2-1/2" H
- Weight: 93 lbs.

TEP594



| Model No. | Mfg. No. | No. of Drawers | Colour | Dimensions | | | Price /Each |
|-----------|------------|----------------|--------|------------|------|----------|-------------|
| | | | | L" | x W" | x H" | |
| TEP595 | EX1606SBBK | 6 | Black | 16 | x 18 | x 34-3/4 | 649.00 |
| TEP596 | EX1606SBL | 6 | Blue | 16 | x 18 | x 34-3/4 | 649.00 |

| Model No. | Mfg. No. | No. of Drawers | Colour | Dimensions | | | Price /Each |
|-----------|------------|----------------|--------|------------|------|----------|-------------|
| | | | | L" | x W" | x H" | |
| TEP593 | EX1603SCBK | 3 | Black | 15-1/4 | x 18 | x 54-3/4 | 849.00 |
| TEP594 | EX1603SCL | 3 | Blue | 15-1/4 | x 18 | x 54-3/4 | 849.00 |



- Drawer slide type: Ball bearing
- Single slide drawer capacity: 100 lbs.
- Double slides drawer capacity: 200 lbs.
- Heavy duty steel construction
- High gloss powder coat finish resists scratches, stains and chemicals
- Full-width polished aluminum drawers
- Secure, tubular coded lock system
- High density foam drawer liners included
- Tool box shell gauge: 20 ga.
- Tool box drawer gauge: 18 ga.
- **Five-year warranty**

TEP621



TEP623

EXTREME TOOLS® EX STANDARD SERIES TOP TOOL CHEST

- 20" cabinet depth holds all your tools but fits in narrow spaces
- 2 side handle fit make moving your top chest easy
- Drawer dimensions:
(5) 33-1/4" W x 17-3/8" D x 2-1/4" H
(5) 16-1/4" W x 17-3/8" D x 2-1/4" H
- Weight: 210 lbs.

TEP622



EXTREME TOOLS® EX STANDARD SERIES ROLLING TOOL CABINET

- 20" cabinet depth holds all your tools but fits in narrow spaces
- (6) 5" x 2" casters support up to 550 lbs. per caster
- 4 locking swivel and 2 rigid casters
- Chrome side handle fits on either end of the roller cabinet
- Drawer dimensions:
(1) 51-3/4" x 17-3/8" x 5"
(3) 33-1/4" x 17-3/8" x 2-1/4"
(1) 33-1/4" x 17-3/8" x 5-1/4"
(1) 33-1/4" x 17-3/8" x 8-1/4"
(3) 16-1/4" x 17-3/8" x 2-1/4"
(1) 16-1/4" x 17-3/8" x 5-1/4"
(1) 16-1/4" x 17-3/8" x 8-1/4"
- Weight: 309 lbs.

TEP624



| Model No. | Mfg. No. | No. of Drawers | Colour | Dimensions | | | Price /Each |
|-----------|------------|----------------|--------|------------|----------|----------|-------------|
| | | | | L" | x W" | x H" | |
| TEP621 | EX5610CHBK | 10 | Black | 55-1/4 | x 19-3/4 | x 20-1/2 | 1349.00 |
| TEP622 | EX5610CHBL | 10 | Blue | 55-1/4 | x 19-3/4 | x 20-1/2 | 1349.00 |

| Model No. | Mfg. No. | No. of Drawers | Colour | Dimensions | | | Price /Each |
|-----------|------------|----------------|--------|------------|------|----------|-------------|
| | | | | L" | x W" | x H" | |
| TEP623 | EX5611RCBK | 11 | Black | 56 | x 20 | x 41-1/2 | 1995.00 |
| TEP624 | EX5611RCBL | 11 | Blue | 56 | x 20 | x 41-1/2 | 1995.00 |

EXTREME TOOLS® EX STANDARD SERIES TRIPLE BANK ROLLING TOOL CABINET

- Drawer slide type: Ball bearing
- Single slide drawer capacity: 250 lbs.
- Double slides drawer capacity: 500 lbs.
- Handle included fits either side of roller cabinet
- Extra deep, high gloss powder coat finish
- Secure, tubular coded locking system
- High density foam drawer liners included
- Stainless steel work surface
- Drawer dimensions:
(1) 41-3/4" W x 27-1/2" D x 4-1/8" H
(1) 11-1/8" W x 27-1/2" D x 2-1/2" H
(2) 11-1/8" W x 27-1/2" D x 5-3/4" H
(1) 11-1/8" W x 27-1/2" D x 12" H
(3) 27-3/4" W x 27-1/2" D x 2-1/2" H
(3) 27-3/4" W x 27-1/2" D x 5-3/4" H
(1) 23" W x 27-1/2" D x 4-1/8" H
(3) 23" W x 27-1/2" D x 2-1/2" H
(3) 23" W x 27-1/2" D x 5-3/4" H
- (6) 6" x 2" casters
(4 locking swivels and 2 rigid)
- Weight: 910 lbs.
- Tool box shell gauge: 18 ga.
- Tool box drawer gauge: 18 ga.
- **Five-year warranty**



TEP633

EXTREME TOOLS® EX STANDARD SERIES DELUXE TOOL CART

- Drawer slide type: Ball bearing
- Slide drawer capacity: 100 lbs.
- 2 heavy duty gas struts hold up the lid
- 4 big drawers plus bottom shelf storage
- Secure tubular coded lock and keys
- Pry bar/tool holders and hangers on both sides of cart
- Sturdy, heavy duty steel construction
- High density foam drawer liners included
- 4 locking swivel casters included
- Weight: 159 lbs.
- Tool box shell gauge: 20 ga.
- Tool box drawer gauge: 20 ga.
- **Five-year warranty**



TEP605

| Model No. | Mfg. No. | No. of Drawers | Colour | Dimensions | | | Price /Each |
|-----------|------------|----------------|--------|------------|------|----------|-------------|
| | | | | L" | x W" | x H" | |
| TEP633 | EX7218RCBK | 18 | Black | 72 | x 30 | x 45-1/2 | 5199.00 |
| TEP634 | EX7218RCBL | 18 | Blue | 72 | x 30 | x 45-1/2 | 5199.00 |

| Model No. | Mfg. No. | No. of Drawers | Colour | Dimensions | | | Price /Each |
|-----------|------------|----------------|--------|------------|----------|----------|-------------|
| | | | | L" | x W" | x H" | |
| TEP605 | EX3204TCBK | 4 | Black | 32-1/4 | x 22-1/4 | x 40-1/2 | 1149.00 |
| TEP606 | EX3204TCBL | 4 | Blue | 32-1/4 | x 22-1/4 | x 40-1/2 | 1149.00 |
| TEP607 | EX3204TCRD | 4 | Red | 32-1/4 | x 22-1/4 | x 40-1/2 | 1149.00 |

TOOLS STORAGE

EXTREME TOOLS® EX PROFESSIONAL SERIES TRIPLE BANK TOP TOOL CHEST

- Drawer slide type: Ball bearing
- Single slide drawer capacity: 300 lbs.
- Double slide drawer capacity: 600 lbs.
- Heavy duty steel construction with double steel wall drawer fronts
- Two gas lifts to support top lid
- Secure, tubular coded locking system
- Self-adjusting spring lever drawer latch assembly for increased security/smooth drawer action
- High density foam drawer liners included
- Double channel spot welded support brackets under each drawer prevents sagging or warping
- Extra deep, high gloss powder coat finish
- Drawer dimensions:
 - (8) 15 1/4" W x 2 5/8" D x 28 1/2" H
 - (2) 15 1/4" W x 5 3/8" D x 28 1/2" H
 - (4) 34 1/4" W x 2 5/8" D x 28 1/2" H
 - (1) 34 1/4" W x 5 3/8" D x 28 1/2" H
- Weight: 675 lbs.
- Tool box shell gauge: 16 ga.
- Tool box drawer gauge: 18 ga.
- **Limited lifetime warranty**



TEP629



| Model No. | Mfg. No. | No. of Drawers | Colour | Dimensions | | | Price /Each |
|-----------|------------|----------------|--------|------------|----|--------|-------------|
| | | | | L" | W" | H" | |
| TEP629 | EX7215CHBK | 15 | Black | 72 | 30 | 26-1/2 | 4549.00 |
| TEP630 | EX7215CHBL | 15 | Blue | 72 | 30 | 26-1/4 | 4549.00 |

EXTREME TOOLS® EX PROFESSIONAL SERIES TRIPLE BANK ROLLING TOOL CABINET

- Drawer slide type: Ball bearing
- Single slide drawer capacity: 300 lbs.
- Double slide drawer capacity: 600 lbs.
- Double steel wall drawer front design
- Includes a self-adjusting spring lever
- Extra deep, high gloss powder coat paint finish is scratch, chemical and stain resistant
- Includes a locking safety drawer
- High density foam drawer liners included
- Double-channel spot-welded support brackets
- (6) 6" x 2" casters (4 locking swivels and 2 rigid) load rated 950 lbs. each
- Drawer dimensions:
 - (1) 50" W x 28-1/8" D x 4-3/4" H
 - (1) 50" W x 28-1/8" D x 2" H
 - (5) 13-3/4" W x 28-1/8" D x 2" H
 - (3) 13-3/4" W x 28-1/8" D x 4-3/4" H
 - (2) 13-3/4" W x 28-1/8" D x 10-1/5" H
 - (2) 32-3/4" W x 28-1/8" D x 2" H
 - (3) 32-3/4" W x 28-1/8" D x 4-3/4" H
- Weight: 1132 lbs.
- Tool box shell gauge: 16 ga.
- Tool box drawer gauge: 18 ga.
- **Limited lifetime warranty**



TEP631



| Model No. | Mfg. No. | No. of Drawers | Colour | Dimensions | | | Price /Each |
|-----------|------------|----------------|--------|------------|----|--------|-------------|
| | | | | L" | W" | H" | |
| TEP631 | EX7217RCBK | 17 | Black | 72 | 30 | 44-3/4 | 6549.00 |
| TEP632 | EX7217RCBL | 17 | Blue | 72 | 30 | 44-3/4 | 6549.00 |

EXTREME TOOLS® EX PROFESSIONAL SERIES POWER WORKSTATION® HUTCH

- Drawer slide type: Roller bearing
- Single slide drawer capacity: 300 lbs.
- Full-width adjustable stainless steel shelf with built-in power strip
- Extra deep, high gloss powder coat finish
- Full-width, polished clear coat anodized aluminum lid handle to avoid oxidation
- Roller bearing slides make opening and closing the lid easy
- Secure, tubular coded locking system
- Full-width door stiffener prevents warping and twisting
- Steel peg board panels on both interior sides of hutch for extra hanging storage
- Tool box shell gauge: 16 ga.
- **Limited lifetime warranty**



TEP614



| Model No. | Mfg. No. | Colour | Dimensions | | | Wt. lbs. | Price /Each |
|-----------|------------|--------|------------|----|--------|----------|-------------|
| | | | L" | W" | H" | | |
| TEP614 | EX5501HCBK | Black | 55 | 30 | 26-3/8 | 286 | 2195.00 |
| TEP615 | EX5501HCL | Blue | 55 | 30 | 26-3/8 | 286 | 2195.00 |
| TEP627 | EX7201HCBK | Black | 72 | 30 | 26-3/8 | 360 | 2849.00 |
| TEP628 | EX7201HCL | Blue | 72 | 30 | 26-3/8 | 360 | 2849.00 |

EXTREME TOOLS® EX PROFESSIONAL SERIES TOOL CABINET

- Drawer slide type: Ball bearing
- Single slide drawer capacity: 300 lbs.
- Double slides drawer capacity: 600 lbs.
- Quick-release slides allow you to remove the shelves so that you can store bigger items
- Side cabinet door can be adjusted to swing from the left or right and can be mounted on either side of your tool box
- Support bracket mounts under toolbox to give added support
- Includes 2 adjustable ball bearing shelves and 4 drawers with ball bearing slides
- High gloss powder coat finish
- Secure, tubular coded lock and key
- High density foam drawer liners included
- Weight: 362 lbs.
- Tool box shell gauge: 16 ga.
- **Limited lifetime warranty**



TEP597



| Model No. | Mfg. No. | No. of Drawers | Colour | Dimensions | | | Price /Each |
|-----------|------------|----------------|--------|------------|----|--------|-------------|
| | | | | L" | W" | H" | |
| TEP597 | EX2404SCBK | 4 | Black | 24 | 31 | 63-3/8 | 2549.00 |
| TEP598 | EX2404SCL | 4 | Blue | 24 | 31 | 63-3/8 | 2549.00 |

EXTREME TOOLS® EX PROFESSIONAL SERIES TOP TOOL CHEST

- Drawer slide type: Ball bearing
- Single slide drawer capacity: 300 lbs.
- Double slides drawer capacity: 600 lbs.
- Two gas lifts to support top lid
- Double steel wall drawer fronts
- Self-adjusting spring lever drawer latch assembly for increased security/smooth drawer action
- Extra deep, high gloss powder coat finish
- Locking system and drawer liners included
- Heavy-duty 16 gauge steel frame
- Drawer dimensions:
 - (4) 15" W x 28" D x 3" H
 - (1) 15" W x 28" D x 5-5/16" H
 - (4) 34" W x 28" D x 3" H
 - (1) 34" W x 28" D x 5-5/16" H
- Weight: 469 lbs.
- Tool box drawer gauge: 18 ga.
- **Limited lifetime warranty**



TEP616

| Model No. | Mfg. No. | No. of Drawers | Colour | Dimensions | | | | Price /Each |
|-----------|------------|----------------|--------|------------|---|----|---|-------------|
| | | | | L" | x | W" | x | H" |
| TEP616 | EX5510CHBK | 10 | Black | 55 | x | 30 | x | 26-3/8 |
| TEP617 | EX5510CHBL | 10 | Blue | 55 | x | 30 | x | 26-3/8 |

EXTREME TOOLS® EX PROFESSIONAL SERIES ROLLING TOOL CABINET

- Drawer slide type: Ball bearing
- Single slide drawer capacity: 300 lbs.
- Double slides drawer capacity: 600 lbs.
- Includes vertical power tool drawer and peg board (power strip with USB ports)
- Heavy-duty, 16 gauge stainless steel work surface
- (6) 6" x 2" casters (4 swivel with locks and 2 rigid)
- Extra deep, high gloss powder coat finish
- Double channel spot welded support brackets under each drawer prevents sagging or warping
- Locking system and drawer liners included
- Drawer dimensions:
 - (1) 49.8" W x 28" D x 4.8" H
 - (1) 49.8" W x 28" D x 1.9" H
 - (2) 13.7" W x 28" D x 1.9" H
 - (1) 13.7" W x 28" D x 3" H
 - (1) 13.7" W x 28" D x 10.8" H
 - (2) 32.7" W x 28" D x 1.9" H
 - (1) 32.7" W x 28" D x 3" H
 - (2) 32.7" W x 28" D x 4.8" H
- Vertical drawer: 18.3" W x 27" D x 30.8" H
- Weight: 975 lbs.
- Tool box shell gauge: 16 ga.
- Tool box drawer gauge: 18 ga.
- **Limited lifetime warranty**



TEP635

| Model No. | Mfg. No. | No. of Drawers | Colour | Dimensions | | | | Price /Each |
|-----------|------------|----------------|--------|------------|---|----|---|-------------|
| | | | | L" | x | W" | x | H" |
| TEP636 | EX7612RCBK | 12 | Black | 76-1/2 | x | 31 | x | 46-1/2 |
| TEP635 | EX7612RCBL | 12 | Blue | 76-1/2 | x | 31 | x | 46-1/2 |

EXTREME TOOLS® TX SERIES ROAD BOX

- Drawer slide type: Friction slides
- Single slide drawer capacity: 100 lbs.
- 16-gauge heavy-duty steel construction
- Durable powder coat finish
- Friction slides on the drawers allow drawers to open smoothly
- 2 mechanical struts hold lid in open position
- Lid folds back for extra top compartment storage
- 2 Over-molded steel handles with plastic grips
- Secure, tubular coded locking system
- High density foam drawer liners included
- Drawer dimensions:
 - (4) 29.84" W x 16" D x 2" H
 - (1) 29.84" W x 16" D x 5" H
- Weight: 151 lbs.
- **Five-year warranty**



| Model No. | Mfg. No. | No. of Drawers | Colour | Dimensions | | | | Price /Each |
|-----------|--------------|----------------|--------|------------|---|----|---|-------------|
| | | | | L" | x | W" | x | H" |
| TEP663 | TXRSB-3605BK | 5 | Black | 36 | x | 18 | x | 27-1/2 |

EXTREME TOOLS® EX PROFESSIONAL SERIES ROLLING TOOL CABINET

- Drawer slide type: Ball bearing
- Single slide drawer capacity: 300 lbs.
- Double slides drawer capacity: 600 lbs.
- Double steel wall drawer front provides greater strength to each drawer
- Includes a self-adjusting spring lever
- Double channel spot welded support brackets under each drawer prevents sagging or warping
- Extra deep, high gloss powder coat paint finish is scratch, chemical and stain resistant
- Locking system and drawer liners included
- (4) 6" x 2" casters (2 locking swivels and 2 rigid) load rated 950 lbs. each
- Includes a locking safety drawer
- Drawer dimensions:
 - (1) 50" W x 28-1/8" D x 4-3/4" H
 - (1) 50" W x 28-1/8" D x 2" H
 - (2) 13-3/4" W x 28-1/8" D x 2" H
 - (1) 13-3/4" W x 28-1/8" D x 4-3/4" H
 - (1) 13-3/4" W x 28-1/8" D x 10-1/5" H
 - (1) 32-3/4" W x 28-1/8" D x 2" H
 - (3) 32-3/4" W x 28-1/8" D x 4-3/4" H
- Weight: 872 lbs.
- Tool box shell gauge: 16 ga.
- Tool box drawer gauge: 18 ga.
- **Limited lifetime warranty**



TEP618



| Model No. | Mfg. No. | No. of Drawers | Colour | Dimensions | | | | Price /Each |
|-----------|------------|----------------|--------|------------|---|----|---|-------------|
| | | | | L" | x | W" | x | H" |
| TEP618 | EX5511RCBK | 11 | Black | 55 | x | 30 | x | 46-3/8 |
| TEP619 | EX5511RCBL | 11 | Blue | 55 | x | 30 | x | 46-3/8 |

EXTREME TOOLS® TX SERIES TOOL CABINET



- Drawer slide type: Ball bearing
- Single slide drawer capacity: 100 lbs.
- Double slides drawer capacity: 200 lbs.
- Includes two-compartment pit box
- 2 large storage compartments with peg board and 1 shelf each
- 4 heavy duty pneumatic tires
- Textured, gloss powder coat finish
- Heavy duty stainless steel top
- Secure, tubular coded locking system
- T-shaped handle comes complete with disc brake controls for easy maneuvering
- Drawer dimensions:
 - (4) 32.5" W x 20.8" D x 1.9" H
 - (2) 32.5" W x 20.8" D x 4.8" H
 - (1) 32.5" W x 20.8" D x 7.8" H (2 compartments):
 - 17.6" W x 23" D x 25.5" H
- Weight: 585 lbs.
- Tool box shell gauge: 18 ga.
- Tool box drawer gauge: 18 ga.
- **Five-year warranty**

TEP660



TEP661

Disc Brake

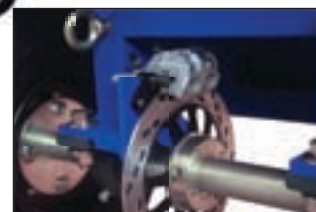

| Model No. | Mfg. No. | No. of Drawers | Colour | Dimensions | | | | Price /Each |
|-----------|-------------|----------------|--------|------------|---|----|---|-------------|
| | | | | L" | x | W" | x | H" |
| TEP660 | TXPIT7009BK | 7 | Black | 70 | x | 30 | x | 48 |
| TEP661 | TXPIT7009BL | 7 | Blue | 70 | x | 30 | x | 48 |
| TEP662 | TXPIT7009RD | 7 | Red | 70 | x | 30 | x | 48 |

TOOLS STORAGE

EXTREME TOOLS® PWS SERIES PORTABLE WORKSTATION® TOOL CABINET

- 16 gauge steel construction with welded seams
- Power tool rack with built-in power strip
- Easy access wrench rack
- 18 screwdriver/nut driver holders
- 88 deep/standard SAE/metric socket pegs
- 2 shelves for additional storage
- Lockable lid secures tools in place when closed
- Gas spring raises lid when unlatched for easy access
- Heavy duty side handles make moving easy
- Weather-resistant textured finish
- Weight: 80 lbs.
- **Five-year warranty**

Tools not included



| Model No. | Mfg. No. | No. of Drawers | Colour | Dimensions | | | Price /Each | |
|-----------|-------------|----------------|--------|------------|---|----|-------------|----|
| | | | | L" | x | W" | x | H" |
| TEP639 | PWS3000TXBK | - | Black | 30 | x | 18 | x | 21 |
| TEP640 | PWS3000TXRD | - | Red | 30 | x | 18 | x | 21 |

EXTREME TOOLS® PWS SERIES PORTABLE WORKSTATION® TOOL CABINET

- 16 gauge steel construction
- Power tool rack with built-in power strip
- Wrench rack that holds 17 SAE and 22 metric combination wrenches
- Holds (64) 1/4" deep/standard socket pegs
- Holds (66) 3/8" deep socket pegs
- Holds (28) 3/8" shallow socket pegs
- Holds (64) 1/2" deep/shallow socket pegs
- Holds (47) screwdriver/ ratchet drivers and extensions slots
- Socket tray lifts to access more tool storage underneath
- Gas spring raises lid when unlatched for easy access
- Lockable lid secures tools in place when closed
- Weather-resistant textured finish
- Weight: 109 lbs.
- **Five-year warranty**

Tools not included



| Model No. | Mfg. No. | No. of Drawers | Colour | Dimensions | | | Price /Each | |
|-----------|-------------|----------------|--------|------------|---|--------|-------------|--------|
| | | | | L" | x | W" | x | H" |
| TEP643 | PWS4100TXBK | - | Black | 41 | x | 17-3/8 | x | 21-1/2 |
| TEP644 | PWS4100TXRD | - | Red | 41 | x | 17-3/8 | x | 21-1/2 |

EXTREME TOOLS® PWS SERIES PORTABLE WORKSTATION® TOOL CABINET

- 16 gauge steel construction
- Power tool rack compartment with built-in power strip
- Pull-out side shelf gives you a convenient work surface
- Pull-out side drawer holds up to 17" laptop computer
- Holds (23) combination wrench pegs
- Holds (49) screwdriver/ratchet driver/extension holders
- Holds (48) 1/4" deep/shallow socket pegs
- Holds (32) 3/8" deep/shallow metric socket pegs
- Holds (22) 3/8" deep/shallow SAE socket pegs
- Holds (32) 1/2" deep/shallow socket pegs
- Holds (22) specialty tool socket pegs
- Holds (13) wide specialty tool slots
- Lockable lid secures tools in place when closed
- Weather-resistant textured finish
- Dual gas struts raise/securely hold lid in place
- Weight: 213 lbs.
- **Five-year warranty**

Tools not included



| Model No. | Mfg. No. | No. of Drawers | Colour | Dimensions | | | Price /Each | |
|-----------|-------------|----------------|--------|------------|---|--------|-------------|--------|
| | | | | L" | x | W" | x | H" |
| TEP645 | PWS4105TXBK | 3 | Black | 41 | x | 23-5/8 | x | 23-1/4 |
| TEP646 | PWS4105TXRD | 3 | Red | 41 | x | 23-5/8 | x | 23-1/4 |

EXTREME TOOLS® PWS STANDARD SERIES ROLLING TOOL CART

- Drawer slide type: Ball bearing
- Single slide drawer capacity: 100 lbs. • Double slide drawer capacity: 200 lbs.
- Heavy duty steel construction:
 - Tool box shell gauge: 20 ga.;
 - Tool box drawer gauge: 20 ga.
- Self-latching full-width aluminum drawers
- (2) swivel, (2) rigid 5" x 2" casters support up to 550 lbs. per caster
- Chrome side handle fits on either end of roller cabinet
- Weather-resistant textured finish paint
- Secure, tubular coded locking system
- High density foam drawer liners included
- **Five-year warranty**

Drawer dimensions (TEP641 & TEP642):

- (3) 26-1/2" W x 15-3/4" D x 5-1/4" H
- (1) 26-1/2" W x 15-3/4" D x 2-1/4" H
- (1) 26-1/2" W x 15-3/4" D x 8-1/4" H



TEP641

Drawer dimensions (TEP647 & TEP648):

- (1) 37-3/8" W x 16-1/2" D x 5-1/4" H
- (3) 23-3/8" W x 16-1/2" D x 2-1/4" H
- (1) 23-3/8" W x 16-1/2" D x 5-1/4" H
- (1) 23-3/8" W x 16-1/2" D x 8-1/4" H
- (3) 11-3/4" W x 16-1/2" D x 2-1/4" H
- (1) 11-3/4" W x 16-1/2" D x 5-1/4" H
- (1) 11-3/4" W x 16-1/2" D x 8-1/4" H



TEP647

Drawer dimensions (TEP649 & TEP650):

- Top drawer: 37.375" W x 17" D x 5.875" H
- (3) 24.25" W x 17" D x 2.875" H
- (1) 24.25" W x 17" D x 5.875" H
- (1) 24.25" W x 17" D x 8.875" H
- (3) 12.625" W x 17" D x 2.875" H
- (1) 12.625" W x 17" D x 5.875" H
- (1) 12.625" W x 17" D x 8.875" H



TEP650



| Model No. | Mfg. No. | No. of Drawers | Colour | Dimensions | | | Wt. lbs. | Price /Each |
|-----------|---------------|----------------|--------|------------|---|--------|----------|-------------|
| | | | | L" | x | W" | x | H" |
| TEP641 | PWS3005RCTXBK | 5 | Black | 30-3/4 | x | 18-1/4 | x | 40-3/4 |
| TEP642 | PWS3005RCTXRD | 5 | Red | 30-3/4 | x | 18-1/4 | x | 40-3/4 |
| TEP647 | PWS4111RCTXBK | 11 | Black | 41 | x | 18 | x | 41-1/2 |
| TEP648 | PWS4111RCTXRD | 11 | Red | 41 | x | 18 | x | 41-1/2 |
| TEP649 | PWS4124RCTXBK | 11 | Black | 41-1/2 | x | 24 | x | 40-1/2 |
| TEP650 | PWS4124RCTXRD | 11 | Red | 41-1/2 | x | 24 | x | 40-1/2 |

JOBBOX® OFFERS:

EZ-LOADER® SKID BOLSTERS

- Fork lift from any side
- Easily load or unload heavy, fully loaded boxes from any sides
- One piece 7-gauge steel skid bolster reinforces the bottom of the box
- With holes for optional caster

TEXTURED POWDER PAINT FINISH

- Improved durability over liquid paint
- 10 times more corrosion resistance
- 5 times more abrasion resistance
- 2 times more chip resistance
- 2 times more scratch resistance

SITE-VAULT™ SECURITY SYSTEM

- 3 locking point system
- Cover plates protect the 3-lock hooks from being bent, broken, cut or pulled out
- Full length, high strength 12-gauge lock console protects the system and reinforces the front of the lid or door
- Requires only one Masterlock® #5 Padlock (SR890-keyed differently; SR867-keyed alike)
- Padlock is securely installed inside the fully welded 14-gauge steel housing
- Exclusive: fluorescent reflective orange tape indicates when the Jobbox® is unlocked



HIGH CAPACITY DROP-FRONT CHESTS

- Site-Vault™ security system with 12-gauge steel lock console with two locking points, full length console and fully welded padlock housing make the lid virtually impossible to bend or pry
- Ez-Loader® skid bolster made of 7-gauge one piece steel allows forklift access from all sides to allow easier loading and unloading
- Grip-rite™ lifting channel
- Power cord access on the top side of the chest
- 37% more capacity for storing taller, bulkier equipment
- Extra wide (44" W), low-incline ramp supports up to 1000 lbs. for safe and easy loading and unloading and is pad-lockable
- 7-gauge, one-piece steel bolsters resist damage when dropped

| Model No. | Dimensions | | | | | Usable Cu. Ft. | Wt. lbs. | Price /Each |
|-----------|------------|---|----|---|----|----------------|----------|-------------|
| | W" | x | D" | x | H" | | | |
| TEP341 | 60 | x | 31 | x | 45 | 41.5 | 340 | 1889.00 |



HIGH CAPACITY DROP-FRONT CHEST ACCESSORY OPTIONS

ACCESSORY SUPPORT BARS

- 1 1/2" square steel tube is the core component needed to support accessories

Model No. TEP342

Price/Each \$49.90



BACK WALL SHELVES

- Ability to tightly secure shelf to chest yet removable when needed
- Includes hardware

Model No. TEP343

Price/Each \$114.00

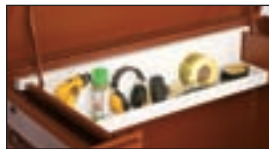

PEG BOARDS

- Can be mixed and matched side by side with the parts bin board (TEP345)

Model No. TEP344

Price/Each \$85.40

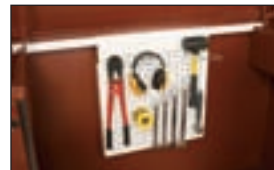

PARTS BIN BOARDS

- Can be mixed and matched side by side with peg board (TEP344)
- Supports most small parts bins

Model No. TEP345

Price/Each \$85.40



TOOL & EQUIPMENT HOOKS

- Industrial grade hooks are perfect for hanging harnesses, rope or chains
- Easy to position and quick to remove
- Package of 6

Model No. TEP346

Price/Each \$39.90



TOOLS STORAGE



PIANO BOXES

- Site-Vault™ security system
- Ez-Loader™ skid bolsters
- Grip-Rite™ recessed lifting channel
- Lift-N-Stow™ bottom shelf
- 3/8 continuous hinges with 1/4" steel pin and extra-large 1" knuckles
- Recessed handles, door opens full 90°
- Two storage bins on both sides of walls
- Formed lid sides welded to lid bolsters resists pry bar entry
- Formed side wall design allows the door to overlap the side walls when closed to resist pry bars and moisture
- Gas springs assist with opening and closing the door. They are embedded in the side walls and protected from damage and jamming. Guards reinforce the side walls.
- TEP347 has one fixed rear shelf and one storage bin on side wall



TEP162



TEP165

- TEP164: Punch holes for hanging safety harnesses, 3 shelves with 500-lb. capacity and 3 storage bins
- TEP165 and TEP166: Tapered drop down ramp that closes with a padlock (not included)



| Model No. | Dimensions | | | | Usable Cu. Ft. | Wt. lbs. | Price /Each | |
|-----------|------------|---|----|---|----------------|----------|-------------|---------|
| | W" | x | D" | x | | | | H" |
| TEP161 | 48 | x | 31 | x | 50 | 38 | 286 | 1469.00 |
| TEP347 | 60 | x | 31 | x | 38 | 34.5 | 283 | 1399.00 |
| TEP162 | 60 | x | 31 | x | 50 | 47.5 | 326 | 1449.00 |
| TEP163 | 74 | x | 31 | x | 50 | 56.5 | 423 | 1799.00 |

| Model No. | Dimensions | | | | Usable Cu. Ft. | Wt. lbs. | Price /Each | |
|----------------------------|------------|---|--------|---|----------------|----------|-------------|---------|
| | W" | x | D" | x | | | | H" |
| HIGH CAPACITY MODEL | | | | | | | | |
| TEP164 | 74 | x | 34 5/8 | x | 63 | 85.7 | 500 | 2499.00 |
| DROP-FRONT MODEL | | | | | | | | |
| TEP165 | 60 | x | 30 | x | 50 | 47.5 | 405 | 2099.00 |
| TEP166 | 74 | x | 30 | x | 50 | 56.5 | 468 | 2549.00 |

JOBBOX® CHESTS

- Site-Vault™ security system
- Ez-Loader™ skid bolsters
- Grip-Rite™ recessed lifting channel
- Staked and welded hinge: 14-gauge steel, 3/8 continuous hinges with 1/4" steel pin and extra-large 1" knuckles
- Heavily reinforced lid and body: Full length A-frame lid bolster, resists bending from weight placed on top and from break-in attempts, welded corner gussets reinforce body



TEP137



TEP158



| Model No. | Dimensions | | | | Usable Cu. Ft. | Wt. lbs. | Price /Each | |
|-----------|------------|---|----|---|----------------|----------|-------------|--------|
| | W" | x | D" | x | | | | H" |
| TEP092 | 36 | x | 20 | x | 23 3/4 | 8.3 | 98 | 559.00 |
| TEP136 | 42 | x | 20 | x | 23 3/4 | 9.3 | 118 | 629.00 |
| TEP137 | 48 | x | 24 | x | 27 3/4 | 15.4 | 148 | 709.00 |
| TEP156 | 60 | x | 24 | x | 27 3/4 | 19.3 | 182 | 879.00 |
| TEP157 | 48 | x | 30 | x | 33 3/8 | 24.3 | 190 | 889.00 |
| TEP158 | 72 | x | 24 | x | 27 3/4 | 23.2 | 220 | 989.00 |

SLOPE LID CHESTS

All the characteristics of a regular Jobox® chest plus:

- Propped lid allows for a flat working surface
- Full length reinforced channel
- Lift-N-Stow™ hinged shelf to store bulky items in the bottom



| Model No. | Dimensions | | | | Usable Cu. Ft. | Wt. lbs. | Price /Each | |
|-----------|------------|---|----|---|----------------|----------|-------------|---------|
| | W" | x | D" | x | | | | H" |
| TEP159 | 60 | x | 30 | x | 39 1/2 | 32.7 | 243 | 1199.00 |

CASTERS

- Heavy-duty casters for added mobility
- Set includes: 2 fixed and 2 swivels
- Hardware included

4"
Model No. TEP230
Price/Each \$229.00

6"
Model No. TEP231
Price/Each \$259.00



WELDER'S BOXES & SMALL CHESTS

- Compact and portable for flexible, secure storage
- A heavily-reinforced 16-gauge steel construction
- **TEP175** offers a heavily-reinforced lid able to resist pry bar entry, a recessed grip channel for opening lid, a bolt cutter proof locking system with a padlock (not included, **SR890**) protecting the lock from bolt cutters and pry bars and tall, strong bottom bolsters
- Staked and welded steel hinges
- **TEP348** is a welder's box that offers a notched upper side for storing tools connected to supply hoses



JOBBOX

| Model No. | Description | Dimensions | | | | Usable Cu. Ft. | Wt. lbs. | Price /Each | |
|-----------|-----------------------------|------------|---|----|---|----------------|----------|-------------|--------|
| | | W" | x | D" | x | H" | | | |
| TEP175 | Small chest w/embedded lock | 31 | x | 18 | x | 15 1/2 | 4 | 70 | 549.00 |
| TEP349 | Small chest w/hasp lock | 30 | x | 16 | x | 12 | 3.3 | 33 | 279.00 |
| TEP348 | Welder's box | 30 | x | 16 | x | 12 | 3.3 | 33 | 239.00 |

JOBSITE CHESTS

- Steel body and lid provide superior security for tools and equipment
- Bolt cutter proof locking system protects padlock inside 12-gauge steel housing
- Heavy-duty hinge is staked and welded to prevent the pin from being driven out to break in
- Lifting handles are protected inside tall, deep recessed to prevent pinched knuckles and damage
- Heavy-duty locking arm secures the lid in the open position
- Tall bottom bolsters for easily moving a loaded chest with a forklift
- 1-year limited warranty



JOBBOX

| Model No. | Dimensions | | | | Usable Cu. Ft. | Wt. lbs. | Price /Each | |
|-----------|------------|---|--------|---|----------------|----------|-------------|--------|
| | W" | x | D" | x | H" | | | |
| TEP226 | 36 | x | 19 1/2 | x | 22 | 6.8 | 85 | 449.00 |
| TEP227 | 42 | x | 20 | x | 23 1/2 | 9.3 | 101 | 519.00 |
| TEP211 | 48 | x | 24 | x | 27 1/2 | 15.4 | 133 | 569.00 |
| TEP212 | 60 | x | 24 | x | 27 1/2 | 19.2 | 155 | 649.00 |

DRAWER CABINETS

- Site-Vault™ security system
- Ez-Loader™ anti-tip skid bolsters: Front of bolster is extended to prevent tipping when drawers are open
- Heavy-duty doors with Grip-Rite™ channel
- Hand or foot operated latch released system
- 4 1/2" deep top shelf and 3" x 3" deep shelves on each door
- 3/8 continuous hinges with hardened 1/4" steel pin and extra-large 1" knuckles
- Three 5/8" steel locking pins per door
- High load capacity drawer: Three 2 1/2" deep drawers have 75-lb. capacity, five 5 1/2" deep drawers have 125-lb. load rating



JOBBOX



Anti-Tip Skid Bolster

| Model No. | Dimensions | | | | Usable Cu. Ft. | Wt. lbs. | Price /Each | |
|-----------|------------|---|--------|---|----------------|----------|-------------|---------|
| | W" | x | D" | x | H" | | | |
| TEP173 | 60 1/8 | x | 30 1/4 | x | 53 1/4 | 58.7 | 610 | 3699.00 |

CABINETS

- Site-Vault™ security system
- Heavy-duty doors with Grip-Rite™ channel
- Hand or foot operated latch released system
- 3/8 continuous hinges with hardened 1/4" steel pin and extra-large 1" knuckles
- Heavy-duty high strength shelves
- Three 5/8" steel locking pins per door
- Five models to choose from:
 - TEP168:** 2 doors, 24" deep
 - TEP169:** 4 doors features front and back access
 - TEP170:** 2 doors, tall closet on right side
 - TEP171:** 2 doors, 30" deep
 - TEP172:** 2 doors, bin and clam shell, has heavy-duty galvanized movable dividers



TEP168



TEP170



TEP169



TEP172

JOBBOX

| Model No. | Dimensions | | | | Usable Cu. Ft. | Wt. lbs. | Price /Each | |
|-----------|------------|---|--------|---|----------------|----------|-------------|---------|
| | W" | x | D" | x | H" | | | |
| TEP168 | 60 1/8 | x | 24 1/4 | x | 60 3/4 | 47.5 | 379 | 1999.00 |
| TEP169 | 60 1/8 | x | 32 1/4 | x | 60 3/4 | 63.7 | 523 | 3099.00 |
| TEP170 | 60 1/8 | x | 24 1/4 | x | 60 3/4 | 47.5 | 366 | 2199.00 |
| TEP171 | 60 1/8 | x | 30 1/4 | x | 60 3/4 | 58.7 | 436 | 2399.00 |
| TEP172 | 72 | x | 24 | x | 60 5/8 | 49 | 522 | 2349.00 |

TOOLS STORAGE

ROLLING WORK BENCHES

- High capacity, fully adjustable interior; drawers and shelves are easy to move to match your requirements, additional drawers and shelves can be added in
- 18-gauge steel drawers with heavy-duty ball bearing glides

Includes: Two fixed and two lockable swivelling casters



TEP176



JOBBOX

| Model No. | Description | Dimensions | | | Usable Cu. Ft. | Wt. lbs. | Price /Each |
|-----------|----------------------------------|------------|----------|----------|----------------|----------|-------------|
| | | W" | x D" | x H" | | | |
| TEP180 | Basic Unit with 6" Casters | 49 7/8 | x 26 7/8 | x 40 5/8 | 24.6 | 264 | 1799.00 |
| TEP176 | 2 Drawers, 2 Shelves, 4" Casters | 43 7/8 | x 26 7/8 | x 38 1/2 | 21.7 | 266.5 | 1869.00 |
| TEP177 | 2 Drawers, 2 Shelves, 6" Casters | 43 7/8 | x 26 7/8 | x 40 1/2 | 21.7 | 279.5 | 2049.00 |
| TEP178 | 4 Drawers, 1 Shelf, 4" Casters | 43 7/8 | x 26 7/8 | x 38 1/2 | 21.7 | 294 | 2069.00 |
| TEP179 | 4 Drawers, 1 Shelf, 6" Casters | 43 7/8 | x 26 7/8 | x 40 1/2 | 21.7 | 307 | 2299.00 |
| TEP181 | 6 Drawers, 1 Shelf, 6" Casters | 49 7/8 | x 26 7/8 | x 40 5/8 | 24.6 | 342 | 2849.00 |

ADDITIONAL DRAWERS & SHELVES:

| For TEP176, TEP177, TEP178 and TEP179 | For TEP180 and TEP181 | Description |
|---------------------------------------|-----------------------|----------------|
| TEP182 | TEP183 | Shelf |
| TEP184 | TEP185 | 2 1/2" Drawer |
| TEP186 | TEP187 | 4 1/2" Drawer |
| TEP188 | TEP189 | 5 1/2" Drawer |
| TEP190 | TEP191 | 10 1/2" Drawer |

ROLLING CLAM SHELL CABINETS

- Rugged 16-gauge steel construction
- Flexible interior storage: Movable top and bottom shelves, open storage closet and lockable storage locker
- Latching hasp: 10-gauge construction reaches a full 4" to align and draw sides together, only key area of padlock is exposed
- Eight 4" heavy-duty casters
- Hinge stop prevents cabinet from fully opening and reduces tipping
- High center handle



Latching Hasp

JOBBOX

| Model No. | Dimensions | | | Usable Cu. Ft. | Wt. lbs. | Price /Each |
|-----------|------------|------|----------|----------------|----------|-------------|
| | W" | x D" | x H" | | | |
| TEP174 | 62 1/2 | x 30 | x 63 1/2 | 72 | 472 | 3169.00 |

FIELD OFFICES

- Site-Vault™ security system
- Ez-Loader™ skid bolsters
- Grip-Rite™ recessed lifting channel
- One handle lock operation, slides down to release bottom doors, slides up for top door
- 30 cu. ft. storage locker, stores items up to 60" length and is opened by a lanyard inside the lower cabinet
- Full length heavy-duty stainless steel hinges resists corrosion and rust
- Built-in bottom door storage shelves
- Overhead tube storage, steel pegboard, storage area for plans and binders, lockable large desktop area and door safety pin latch



JOBBOX

| Model No. | Dimensions | | | Usable Cu. Ft. | Wt. lbs. | Price /Each |
|-----------|------------|------|------|----------------|----------|-------------|
| | W" | x D" | x H" | | | |
| TEP167 | 63 | x 42 | x 80 | 100 | 660 | 3749.00 |

TRUCK CHESTS

- Gear-Lock II™ locking system offers a self-adjusting dual rotary lock system, a ratcheting action that pulls lid tight to resist over 2000 lbs. of prying and pulling force, and the highest level of security and moisture resistance available
- Self-aligning latch hoops, pivots from side to side to align with Gear-Lock II™ dual rotary lock system
- Heavy-duty gas spring guards protects the gas springs from damage and jamming
- High-strength deep bevelled edge lid provides increased strength and superior weather protection
- Recessed hinge on all chests, allows lid to be raised fully even when chest is placed flush against truck bed
- 5-year limited warranty



TEP214



TEP248



| Model No. | Finish | Dimensions | | | | Usable Cu. Ft. | Wt. lbs. | Price /Each | |
|-----------------|-----------|------------|---|--------|---|----------------|----------|-------------|---------|
| | | W" | x | D" | x | H" | | | |
| ALUMINUM | | | | | | | | | |
| TEP214 | Clearcoat | 59 3/8 | x | 20 1/4 | x | 19 | 10.2 | 49 | 1049.00 |
| TEP247 | Black | 59 3/8 | x | 20 1/4 | x | 19 | 10.2 | 49 | 989.00 |
| STEEL | | | | | | | | | |
| TEP248 | White | 59 1/8 | x | 20 1/4 | x | 19 | 10.2 | 120 | 989.00 |

CROSSOVERS TRUCK BOXES

- Gear-Lock II™ locking system offers a self-adjusting dual rotary lock system, a ratcheting action pulls lid tight to resist over 2000 lbs of prying and pulling force and provides the highest level of security and moisture resistance available
- Self-latching latch hoops cannot be bent or pried out of the lock, automatically aligns in locking system and guarantees a tight seal first time every time
- Deep beveled edge lid design allows body to fit deeper inside the lid keeping out wind driven rain and prying tool and creates a superior moisture protection and security for your cargo
- Channel reinforced front panel, one-piece box body construction, full length bolster reinforcement
- Full-length lock console, drill resistant push button locks
- Bulb-shaped automotive weather stripping, 90° lid opening, small part bin storage and lift out storage tray
- Available in durable Armorbrite™ white powder paint finish steel or aluminum clear coat, in gull wing or single lid
- **Aluminum crossover truck box** has RSL™ rigid structural lid 3-layer lid has an inner core of rigid foam and reverse bevelled liner for superior strength and rigidity
- **Steel crossover truck box** has an Armorbrite™ white powder paint finish for superior rust resistance
- 5-year limited warranty



TEP194
Gull Wing



TEP192
Single Lid

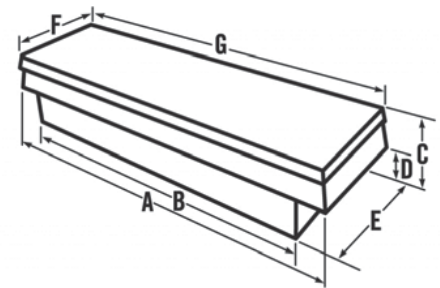

SINGLE LID CROSSOVERS TRUCK BOXES

| Model No. | Finish | A" | B" | C" | Dimensions | | | | Usable Cu. Ft. | Wt. lbs. | Price /Each |
|-----------------|-----------|--------|--------|--------|------------|--------|----|----|----------------|----------|-------------|
| | | | | | D" | E" | F" | G" | | | |
| ALUMINUM | | | | | | | | | | | |
| TEP192 | Clearcoat | 70 1/8 | 60 1/8 | 18 7/8 | 12 | 20 1/4 | 21 | 72 | 10.7 | 75 | 1229.00 |
| TEP232 | Black | 70 1/8 | 60 1/8 | 18 7/8 | 12 | 20 1/4 | 21 | 72 | 10.7 | 75 | 1199.00 |
| TEP234 | Clearcoat | 70 1/8 | 60 1/8 | 18 7/8 | 12 | 29 1/4 | 30 | 72 | 17.5 | 97.5 | 1308.00 |
| TEP235 | Black | 70 1/8 | 60 1/8 | 18 7/8 | 12 | 29 1/4 | 30 | 72 | 17.5 | 97.5 | 1276.00 |
| STEEL | | | | | | | | | | | |
| TEP196 | White | 70 1/8 | 60 1/8 | 18 7/8 | 12 | 20 1/4 | 21 | 72 | 10.7 | 156 | 1139.00 |
| TEP241 | White | 70 1/8 | 60 1/8 | 18 7/8 | 12 | 29 1/4 | 30 | 72 | 17.5 | 191 | 1286.00 |

GULL WING CROSSOVERS TRUCK BOXES

| Model No. | Finish | A" | B" | C" | Dimensions | | | | Usable Cu. Ft. | Wt. lbs. | Price /Each |
|-----------------|-----------|--------|--------|--------|------------|--------|----|----|----------------|----------|-------------|
| | | | | | D" | E" | F" | G" | | | |
| ALUMINUM | | | | | | | | | | | |
| TEP194 | Clearcoat | 70 1/8 | 60 1/8 | 20 1/2 | 12 | 20 1/4 | 21 | 72 | 11.7 | 64 | 1372.00 |
| TEP239 | Black | 70 1/8 | 60 1/8 | 20 1/2 | 12 | 20 1/4 | 21 | 72 | 11.7 | 64 | 1338.00 |
| STEEL | | | | | | | | | | | |
| TEP198 | White | 70 1/8 | 60 1/8 | 20 1/2 | 12 | 20 1/4 | 21 | 72 | 11.7 | 142 | 1154.00 |

TOOLS STORAGE

INNERSIDES TRUCK BOXES

- Gear-Lock II™ locking system offers a self-adjusting dual rotary lock system, ratcheting action pulls lid tight to resist over 2000 lbs. of prying and pulling force and provides the highest level of security and moisture resistance available
- Self-latching latch hoops cannot be bent or pried out of the lock, automatically aligns in locking system and guarantees a tight seal first time every time
- Deep bevelled edge lid design allows body to fit deeper inside the lid keeping out wind driven rain and prying tool and creates a superior moisture protection and security for your cargo
- Full-length storage bin, provides quick and easy access to small parts and tools
- Includes support legs and mounting kit
- 5-year limited warranty



TEP242



TEP245

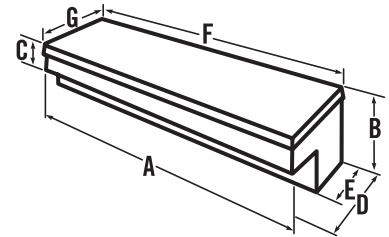

| Model No. | Finish | A" | B" | C" | Dimensions | | | Usable Cu. Ft. | Wt. lbs. | Price /Each |
|-----------------|-----------|----|--------|-------|------------|--------|--------|----------------|----------|-------------|
| | | | | | D" | E" | F" | | | |
| ALUMINUM | | | | | | | | | | |
| TEP242 | Clearcoat | 57 | 13 3/4 | 6 7/8 | 14 3/4 | 8 1/2 | 57 3/4 | 3.6 | 41.5 | 899.00 |
| TEP243 | Black | 57 | 13 3/4 | 6 7/8 | 14 3/4 | 8 1/2 | 57 3/4 | 3.6 | 41.5 | 899.00 |
| TEP371 | Clearcoat | 57 | 13 3/4 | 6 7/8 | 17 | 11 1/8 | 57 3/4 | 4.5 | 44.5 | 999.00 |
| TEP372 | Black | 57 | 13 3/4 | 6 7/8 | 17 | 11 1/8 | 57 3/4 | 4.5 | 44.5 | 999.00 |
| STEEL | | | | | | | | | | |
| TEP245 | White | 57 | 13 5/8 | 6 7/8 | 14 5/8 | 8 1/2 | 57 1/2 | 4.5 | 86.5 | 869.00 |
| TEP376 | White | 57 | 13 5/8 | 6 7/8 | 17 1/4 | 11 1/8 | 57 1/2 | 4.9 | 96.5 | 939.00 |

TOPSIDES TRUCK BOXES

- 3-point locking system: Doors are locked at the top and both sides to resist break-ins, covers protect the locking system and reinforce the high-strength doors
- Full-length hinge on each door provides extra security against break-ins and gives extra durability and reliable service
- Handles have reinforced cam locks and are sealed to prevent moisture from getting inside
- High-strength coated galvanized steel aircraft cable door supports handle 300-lb. load
- 12" tall door openings for easier access, door frames are recessed for superior strength and security
- Automatic-style bulb weather stripping surrounds the door opening to seal out moisture and dust
- **Aluminum topside** features 0.100-gauge aluminum reinforced doors, center posts and ends
- **Steel topside** feature 14-gauge steel reinforced doors, center posts and ends
- 5-year limited warranty



TEP377



TEP380



| Model No. | Finish | Dimensions | | | Usable Cu. Ft. | Wt. lbs. | Price /Each |
|-----------------|-----------|------------|---|---------|----------------|----------|-------------|
| | | W" | x | D" | x | H" | |
| ALUMINUM | | | | | | | |
| TEP377 | Clearcoat | 72 | x | 13 3/16 | x | 16 11/16 | 1259.00 |
| TEP378 | Black | 72 | x | 13 3/16 | x | 16 11/16 | 1259.00 |
| STEEL | | | | | | | |
| TEP380 | Black | 72 | x | 13 3/16 | x | 16 9/16 | 1239.00 |

UNDERBED TRUCK BOXES

- 3-point locking system locks the door at the top and on both sides for strength and durability and draws the high-strength door tight against the bulb-shaped weather stripping to seal out moisture and dust
- Rotating T-Handle draws the door tight against the weather stripping, and drill resistant lock cylinder prevents break-ins
- Heavy-duty housing covers the locking system and locking rods to prevent damage and jamming. Housing adds extra strength to the door
- 3/4" wide rain gutter surrounds the door opening to channel moisture around the opening to protect the contents
- Quick-release keyway connectors allow the door end of the support cable to be easily and quickly disconnected to allow the door to drop down
- **Steel underbed truck box** has industrial grade hinges for the have rugged 3" long, 7/8" outside diameter hinges with 1/2" diameter stainless steel pin
- **Aluminum underbed truck box** has continuous 3/8" diameter hinges with 1" knuckles for superior strength and durability
- Available in steel Armor-Brite™ powder paint or 0.100 gauge aluminum



STEEL

| White Model No. | Black Model No. | Dimensions W" x D" x H" | Wt. lbs. | Price /Each |
|-----------------|-----------------|-------------------------|----------|-------------|
| TEP199 | TEP249 | 18 x 18 x 18 | 55 | 580.00 |
| TEP200 | TEP250 | 24 x 18 x 18 | 68 | 580.00 |
| TEP201 | TEP251 | 30 x 18 x 18 | 80 | 659.00 |
| TEP202 | TEP252 | 36 x 18 x 18 | 92 | 719.00 |
| TEP203 | TEP253 | 48 x 18 x 18 | 117 | 799.00 |
| TEP204 | TEP254 | 60 x 18 x 18 | 142 | 959.00 |

ALUMINUM

| Model No. | Dimensions W" x D" x H" | Wt. lbs. | Price /Each |
|-----------|-------------------------|----------|-------------|
| TEP205 | 18 x 18 x 18 | 35 | 699.00 |
| TEP206 | 24 x 18 x 18 | 40 | 739.00 |
| TEP207 | 30 x 18 x 18 | 44 | 829.00 |
| TEP208 | 36 x 18 x 18 | 48 | 879.00 |
| TEP209 | 48 x 18 x 18 | 61 | 1029.00 |
| TEP210 | 60 x 18 x 18 | 74 | 1189.00 |

MOUNTING BRACKETS

- Heavy-duty 2" C-channel brackets for mounting underbed boxes
- Brackets have multiple mounting holes for easy installation
- Sold in pairs

| Model No. | Description | Wt. lbs. | Price /Each |
|-----------|------------------------------|----------|-------------|
| TEP360 | Mounting brackets, 18" x 18" | 15 | 169.00 |
| TEP361 | Mounting brackets, 24" x 24" | 15 | 218.00 |

QUICK PAC™ REMOVABLE SIDE RACKS

- Pair of easy-to-install removable racks for carrying a ladder, canoe, light load of conduit, lumber or other long material
- Heavy-duty front and rear mounting base bolt to the truck bed and side wall for stability and strength
- Can be mounted on either side
- 14-gauge, 1 1/2" square steel uprights support up to 250-lbs. load
- Support arms adjust from 18" to 32" in width
- Superior corrosion resistant finish with yellow zinc dichromate undercoat with marine grade polyester epoxy powder coat finish
- Lifetime frame warranty

Model No. TEP255
Price/Each \$419.00





Help control & divert traffic

100% PVC construction
High density base for maximum stability
Superior temperature resistance



3M

| | |
|---|--|
| ADF Filters..... | 1126 |
| Adhesive Bandages..... | 741 |
| Ambient Air Pump Respirators..... | 466, 481, 1127 |
| Anti-Skid Tape..... | 873 |
| Backing Pads..... | 921, 925, 935 |
| Box Sealing Tape..... | 1410-1411, 1429 |
| Bristle Brushes..... | 921, 1271 |
| Bristle Discs..... | 921 |
| Burnishing Pads..... | 362 |
| Butterfly Wound Closures..... | 742 |
| Compresses..... | 746 |
| Conspicuity Tape..... | 850 |
| Contact Cement..... | 1029 |
| Cut & Polish Wheels..... | 938 |
| Cut-Off Wheels..... | 912, 916 |
| Deburring Wheels..... | 936, 938, 1271 |
| Degreasers, Heavy-Duty..... | 319, 1005, 1036 |
| Disc Holder Pads..... | 923, 925, 927, 935-936, 938 |
| Display Hangers, Merchandise..... | 1435 |
| Disposable Respirators..... | 448-449 |
| Document Laminators..... | 1574 |
| Double Sided Tape..... | 1416 |
| Duct Tape..... | 1415 |
| Dust Mask Dispensers..... | 453 |
| Ear Plugs | |
| Dispensers..... | 427 |
| Disposable..... | 425 |
| Fabric Bandages..... | 741 |
| Faceshields..... | 412 |
| Filament Tape..... | 1412 |
| Filter Plates..... | 1126 |
| Finishing Wheels..... | 938 |
| Flap Brushes..... | 937 |
| Flap Discs..... | 918 |
| Flap Wheels..... | 919, 937 |
| Full Face Respirators..... | 455 |
| Glasses | |
| Reading..... | 399 |
| Safety..... | 399-401 |
| Glue, Sticks..... | 1418 |
| Glue Guns..... | 1418 |
| Goggles, Safety..... | 406 |
| Grinding Wheels, Type 27..... | 915 |
| Half Mask Respirators..... | 454-455 |
| Hand Pad Holders..... | 933-934, 938 |
| Hand Scrubbers..... | 302 |
| Helmets, Welding..... | 1126-1127 |
| Magnifier Plates..... | 1126 |
| Masking Tape..... | 1414 |
| Packing List Envelopes..... | 1449 |
| Pads, Cleaning..... | 292, 362 |
| PAPR Respirators..... | 466, 471-473, 475, 477, 479, 481, 1127 |
| Penetrants, 5-Way..... | 1013 |
| Plastic Bandages..... | 741 |
| Polyethylene Foam Tape..... | 1416 |
| Positive Pressure Respirators..... | 466, 477 |
| Power-Lock Discs..... | 925, 935 |
| Resin Fibre Discs..... | 923, 925 |
| Respirators | |
| Cartridges..... | 456, 466, 472-473, 475, 477 |
| Filters..... | 456-457, 475 |
| Fit Test Kits..... | 465 |
| Headgear..... | 473, 479, 1127 |
| Sanding Sponges..... | 933 |
| Sandpaper..... | 930, 932 |
| Scouring Pads..... | 302, 320, 362 |
| Self-Stick Bandages..... | 742, 746 |
| Sheathing Tape..... | 1437 |
| Sound Level Meters, Integral Probe..... | 440, 1480 |
| Spray Adhesives..... | 1036, 1418 |
| Spray Lubricants..... | 1008 |
| Stethoscopes..... | 756 |
| Stick-On Discs..... | 927 |
| Stripping Pads..... | 362 |
| Supplied Air Respirators..... | 466, 479 |
| Surface Conditioning Belts..... | 937 |
| Surface Conditioning Discs..... | 934-936, 938 |
| Surface Conditioning Pads..... | 302, 933 |

| | |
|---------------------------------|--------------|
| Surface Conditioning Rolls..... | 930, 933-934 |
| Tape | |
| Electrical..... | 1417, 1544 |
| First Aid..... | 744 |
| Office..... | 1580 |
| Tape Dispensers | |
| Filament Tape..... | 1411 |
| Gummed Tape..... | 1411 |
| Two-Way Tape..... | 1416 |
| Vinyl Tape..... | 1416 |
| Wipes..... | 465 |

ACCENT HOME

| | |
|---------------------------|----|
| Small Parts Cabinets..... | 33 |
|---------------------------|----|

ACCUFORM SIGNS

| | |
|-----------------------------------|----------------------------------|
| Accident Prevention Tags..... | 786-788, 790 |
| Admittance Signs..... | 803-810, 813 |
| Blank Tags..... | 791-792 |
| Cable Ties..... | 793 |
| Chemical Hazard Signs..... | 804, 808 |
| Confined Space Signs..... | 804, 808 |
| CSA Standard Signs..... | 814-817 |
| Direction Signs..... | 811 |
| Ear Protection Signs..... | 806, 809 |
| Electrical Hazard Signs..... | 804-805, 808 |
| Exit Signs..... | 807, 810 |
| Eye Protection Signs..... | 806, 809 |
| Fall Protection, Signs..... | 806 |
| Fire Protection, Signs..... | 653, 807, 810, 812, 817, 822 |
| First Aid, Signs..... | 727, 805, 809, 812 |
| Floor Signs..... | 813 |
| GHS | |
| Information Centres..... | 848 |
| Information Charts..... | 847 |
| Safety Labels..... | 844-845 |
| Wallet Card..... | 844 |
| Hazardous Materials Signs..... | 808 |
| ISO Safety Labels..... | 818-819, 845 |
| Machinery & Operations Signs..... | 804-805, 809 |
| Maintenance Signs..... | 808-809, 813 |
| MSDS | |
| Binders..... | 849 |
| Information Centers..... | 848-849 |
| No Smoking Signs..... | 806-808, 810 |
| Parking Signs..... | 810 |
| Pipe Markers..... | 833-841 |
| Protective Wear Signs..... | 806, 809 |
| Safety Signs..... | 727, 806, 809, 849 |
| Scoreboard Signs..... | 822-823 |
| SDS | |
| Binders..... | 849 |
| Information Centre..... | 848-849 |
| Poster..... | 847 |
| Self-Adhesive Letters..... | 800 |
| Self-Adhesive Numbers..... | 800 |
| Shipping & Receiving Signs..... | 813 |
| Tags, Lockout..... | 786-788, 790 |
| Traffic Signs..... | 210, 807, 810, 812, 820-821, 851 |
| Washroom Sign..... | 813 |
| Wheel Locks..... | 782 |
| WHMIS | |
| Information Charts..... | 847 |
| Labels..... | 846 |
| Pictograms..... | 845-846 |
| Posters..... | 847 |

AIGNER INDEX

| | |
|--------------------------------|------------------|
| Aisle Signs..... | 12, 48 |
| Label Holders..... | 5, 12, 48, 72-73 |
| Label Makers, Accessories..... | 5, 12 |
| Magnetic Tags..... | 12 |

AIR MASTER

| | |
|-------------------|------------|
| Ceiling Fans..... | 1498 |
| Drum Fans..... | 1497, 1502 |

| | |
|------------------------|-----------|
| Exhaust Fans..... | 1501 |
| Pedestal Fans..... | 1497-1499 |
| Wall Mounted Fans..... | 1497-1498 |

AIRFLOW

| | |
|---------------------------------|------|
| Integral Probe Anemometers..... | 1486 |
|---------------------------------|------|

AKRO-MILS

| | |
|---------------------------|----|
| Small Parts Cabinets..... | 34 |
| Stacking Bins..... | 5 |

ALB PLUS

| | |
|--------------------------|-------------------|
| Cabinets, Storage..... | 97-98, 1561, 1563 |
| Dollies, Steel Deck..... | 97, 103 |
| Lockers, Steel..... | 104 |

ALDON

| | |
|-------------------|-----|
| Rail Chocks..... | 210 |
| Wheel Chocks..... | 210 |

ALEMITE

| | |
|---------------------------------|-----------|
| Grease Guns..... | 997 |
| Grease Pumps..... | 999 |
| Pipe Fittings, Lubrication..... | 999, 1001 |

ALGOOD

| | |
|--------------|---------|
| Casters..... | 229-230 |
| Wheels..... | 232-233 |

ALLEGRO INDUSTRIES

| | |
|--------------------------|---------|
| Axial Blowers..... | 488-489 |
| Centrifugal Blowers..... | 489 |
| Fan Guards..... | 489 |
| Guard Rails..... | 489 |
| Knee Pads, Leather..... | 1133 |
| Manhole Lid Lifters..... | 489 |
| Manhole Shields..... | 489 |
| Portable Blowers..... | 488 |
| Tent Heaters..... | 489 |
| Work Tents..... | 489 |

ALLEN INDUSTRIAL HAND TOOLS

| | |
|---------------|-----------|
| Hex Keys..... | 1346-1347 |
|---------------|-----------|

ALLIANCE PLASTICS

| | |
|------------------|------|
| Poly Tubing..... | 1430 |
|------------------|------|

ALLPAX

| | |
|----------------------------|------|
| Rubber Cutting Knives..... | 1371 |
|----------------------------|------|

ALL-VAC INDUSTRIES

| | |
|-----------------------|---------|
| Magnetic Lifters..... | 196 |
| Vacuum Cups..... | 196-197 |

ALNOR

| | |
|-------------------------|------|
| Balometers..... | 1488 |
| Temperature Probes..... | 1488 |

ALTE-REGO

| | |
|-----------------------------------|------------------------|
| Bags, Laundry..... | 303 |
| Construction, Vapor Barriers..... | 1437 |
| Garbage Bags..... | 278, 281-282, 383, 761 |
| Gaylord Liners..... | 280 |
| Liners, Container..... | 280 |
| Pallet Covers..... | 1423 |
| Poly Tubing..... | 1437 |

BRAND INDEX

| | |
|-----------------------------|-----|
| Seat Cover, Automotive..... | 280 |
| Tire Bags..... | 280 |

AMANO CINCINNATI

| | |
|------------------|------|
| Time Clocks..... | 1575 |
|------------------|------|

AMERICAN WATER BROOM

| | |
|-------------------|-----|
| Water Brooms..... | 377 |
|-------------------|-----|

AMPCO

| | |
|--------------------------------------|------------|
| Ball Pein Hammers, Non-Sparking..... | 1380 |
| Cabinet Tip Screwdrivers..... | 1383 |
| Cross-Point Screwdrivers..... | 1383, 1386 |
| Crowbars, Non-Sparking..... | 1380 |
| Curved Blade Knives..... | 1382, 1386 |
| Curved Claw Hammers..... | 1380 |
| Diagonal Cutters..... | 1383 |
| Flat Tip Screwdrivers..... | 1383, 1386 |
| Hammers, Non-Sparking..... | 1380, 1386 |
| Hand Chisels..... | 1381 |
| Hand Scrapers, Non-Sparking..... | 1382, 1386 |
| Hex Keys, Non-Sparking..... | 1383 |
| Linoleum Knives..... | 1382 |
| Maintenance Brushes..... | 1383, 1386 |
| Mallets..... | 1380 |
| Non-Sparking Tool Kits..... | 1386 |
| Non-Sparking Tools | |
| Pliers..... | 1383, 1386 |
| Wedge..... | 1381 |
| Wrenches..... | 1384-1386 |
| Picks..... | 1381 |
| Pinch Bars..... | 1380 |
| Pry Bars | |
| Crate Openers..... | 1380, 1386 |
| Nail Pullers..... | 1380 |
| Non-Sparking..... | 1380 |
| Putty Knives | |
| Flexible..... | 1382 |
| Stiff..... | 1382, 1386 |
| Round Point Shovels..... | 1381 |
| Scoop Shovels..... | 1381 |
| Scrapers, Drywall..... | 1382 |
| Screwdrivers, Sets..... | 1383 |
| Sledge Hammers, Non-Sparking..... | 1380 |
| Sockets, Non-Sparking..... | 1385 |
| Spatulas, Non-Sparking..... | 1382 |
| Square Point Shovels..... | 1381 |
| Straight Blade Knives..... | 1382, 1386 |
| Utility Knives..... | 1382 |

AMPROBE

| | |
|--------------------|------------|
| Cable Tracers..... | 1468, 1543 |
|--------------------|------------|

ANSELL

| | |
|--------------------------------|-------------------|
| Chemical Resistant Gloves..... | 583, 586-589 |
| Coated Gloves..... | 562-577, 580, 591 |
| Cut Resistant Gloves..... | 575-578, 580 |
| Disposable Gloves..... | 594, 598-599 |
| Gloves, Holders..... | 593 |
| Winter Lined Gloves..... | 571, 593, 626 |

ANTHONY STEEL MFG.

| | |
|-----------------------------|-----|
| Cabinets, Storage..... | 97 |
| Gas Cylinder, Lockouts..... | 106 |
| Lockers, Steel..... | 106 |

APEX

| | |
|----------------------------|------|
| Bit Holders..... | 1343 |
| Cross-Point Bits..... | 1345 |
| Hex Bits..... | 1344 |
| Hex Square Drive Bits..... | 1343 |
| Nutsetters..... | 1343 |

| | |
|-------------------------|-----------|
| Posidriv® Bits..... | 1345 |
| Slotted Bits..... | 1344-1345 |
| Square Recess Bits..... | 1344-1345 |
| Torque Bits..... | 1343 |
| Torx® Bits..... | 1343-1344 |
| Tri-Wing Bits..... | 1344 |

ARMSTRONG TOOLS

| | |
|---|----------------------------------|
| Adjustable Wrenches..... | 1330 |
| Aligning Punches..... | 1369 |
| Angle Wrenches..... | 1335 |
| Ball Pein Hammers, Fiberglass Handle..... | 1365 |
| Box Wrenches | |
| 15 Degree Offset..... | 1336 |
| 25 Degree Offset..... | 1336 |
| 45 Degree Offset..... | 1336 |
| Geared..... | 1331 |
| Brass Hammers..... | 1365 |
| Cape Chisels..... | 1368 |
| C-Clamps..... | 1289 |
| Center Punches..... | 1368 |
| Chain Nose Pliers..... | 1348 |
| Chisel Holders..... | 1367 |
| Cold Chisels..... | 1367-1368 |
| Combination Wrenches..... | 1331 |
| Sets..... | 1337 |
| Convertible Pliers..... | 1353 |
| Copper Hammers..... | 1365 |
| Dead Blow Hammers..... | 1363 |
| Diagonal Cutters..... | 1348 |
| Drift Punches..... | 1369 |
| Flare Nut Wrenches..... | 1335-1336 |
| Flex Head Wrenches..... | 1335 |
| Gear Wrenches, Sets..... | 1337 |
| Hex Bit Sockets..... | 1315-1316 |
| Impact Sockets..... | 1323-1325, 1327 |
| Lineman's Pliers..... | 1348 |
| Mallets..... | 1363 |
| Needle Nose Pliers..... | 1349 |
| Nut Drivers | |
| Hollow Shaft..... | 1342 |
| Sets..... | 1342 |
| Open End Wrenches..... | 1335 |
| Pin Punches..... | 1369 |
| Pinch Bars..... | 1367 |
| Power Sockets..... | 1323, 1327 |
| Pry Bars | |
| Rolling Head..... | 1367 |
| with Handle..... | 1367 |
| Pump Wrenches..... | 1335 |
| Ratchets | |
| 1 1/2" Drive..... | 1324 |
| 1" Drive..... | 1324 |
| 1/2" Drive..... | 1315, 1321 |
| 1/4" Drive..... | 1324 |
| 3/4" Drive..... | 1322 |
| 3/8" Drive..... | 1316, 1319 |
| Retaining Ring Pliers..... | 1353 |
| Rolling Head Bars..... | 1367 |
| Slip Joint Pliers..... | 1348 |
| Socket Accessories..... | 1314-1316, 1319, 1321-1324, 1327 |
| Socket Sets, Standard..... | 1314-1315 |
| Sockets, Standard..... | 1314-1316, 1319, 1321-1322 |
| Soft Face Hammers..... | 1363 |
| Spanner Wrenches..... | 1330 |
| Starting Punches..... | 1370 |
| Striking Face Wrenches..... | 1331 |
| Structural Wrenches..... | 1330 |
| Tongue & Groove Pliers..... | 1348 |
| Torque Meters..... | 1329 |
| Torque Multipliers..... | 1328 |
| Torque Wrenches..... | 1328 |

ARROW

| | |
|---------------------------|-----------|
| Carton Staplers..... | 1446-1447 |
| Nail Guns, Electric..... | 1446 |
| Nails, for Nail Guns..... | 1446 |

Staples

| | |
|------------------------|-----------|
| Carton Staplers..... | 1446-1447 |
| Pneumatic Stapler..... | 1447 |

ATLAS GRAHAM

| | |
|--------------------------|----------------------------|
| Angled Brooms..... | 290 |
| Boot Covers..... | 289, 889 |
| Buckets..... | 305 |
| Corn Brooms..... | 289-290 |
| Dusters, Janitorial..... | 302 |
| Dustpans..... | 290 |
| Extension Poles..... | 287-288, 293, 297-298, 302 |
| Floor Scrapers..... | 298 |
| Frames, Dust Mop..... | 293, 302 |
| Litter Scoops..... | 290 |
| Maintenance Brushes..... | 26, 300-301 |
| Microfiber Cloths..... | 293 |
| Mops | |
| Dust..... | 293, 295 |
| Wet..... | 292-293, 295, 304-306 |
| Pads, Cleaning..... | 292 |
| Pot Brushes..... | 26, 301 |
| Push Brooms..... | 287-290, 301 |
| Scouring Pads..... | 292 |
| Scrub Brushes..... | 26, 291, 300 |
| Shelf Carts..... | 168 |
| Shoe Covers..... | 289, 889 |
| Squeegees..... | 297-299, 301 |
| Switch Brooms..... | 290 |
| Toilet Bowl Brushes..... | 349 |
| Vehicle Brushes..... | 292 |
| Whitewash Brushes..... | 292 |
| Window Brushes..... | 292 |

ATLAS WELDING ACCESSORIES

| | |
|--------------------------------|-----------|
| Chipping Hammers, Welding..... | 1087-1088 |
|--------------------------------|-----------|

ATRIX

| | |
|------------------|-----|
| Vacuums | |
| Accessories..... | 361 |
| Wet / Dry..... | 361 |

AURORA TOOLS

| | |
|-------------------------------------|-----------------------------|
| Adjustable Wrenches..... | 1309-1312, 1332 |
| Angle Grinders, Air..... | 1204 |
| Ball Pein Hammers, Wood Handle..... | 1309-1310, 1312, 1362, 1365 |
| Bench Vises..... | 1293 |
| Blades, Packaging Knife..... | 1440 |
| Bolt Cutters..... | 1360 |
| Booster Cables..... | 1542 |
| Broadcast Spreaders..... | 364, 370 |
| Cabinet Tip Screwdrivers..... | 1309-1312, 1338 |
| Cable Ties..... | 1452 |
| Calipers, Digital..... | 1275, 1309-1310 |
| Carton Staplers..... | 1446 |
| Caulking Guns..... | 1024 |
| C-Clamps..... | 1288 |
| Center Punches..... | 1309-1310, 1312, 1368, 1370 |
| Chippers, Air..... | 1088, 1207 |
| Claw Hammers..... | 1362 |
| Club Hammers..... | 369, 1365 |
| Cold Chisels..... | 1309-1310, 1312, 1367, 1370 |
| Combination Wrenches..... | 1332 |
| Sets..... | 1309-1310, 1312, 1332 |
| Control Valves..... | 1000 |
| Cord Reels, Extension Cords..... | 1537 |
| Cross-Point Screwdrivers..... | 1309-1312, 1338 |
| Curved Claw Hammers..... | 1309-1312, 1364 |
| Cut-Off Tools, Air..... | 1204 |
| Dead Blow Hammers..... | 1309-1312, 1362-1363 |
| Diagonal Cutters..... | 1309-1312, 1348, 1353 |
| Die Grinders, Air..... | 1204 |
| Drain Spades..... | 366 |
| Drift Punches..... | 1309-1310, 1369-1370 |
| Drills, Air..... | 1205 |

| | |
|--|-----------------------------|
| Extension Cords | |
| Single Outlet | 1535-1537 |
| Triple Outlet | 1535, 1537 |
| Flashlights | |
| AA Cell | 1517 |
| AAA Cell | 1517 |
| D Cell | 1517 |
| Mini | 1517 |
| Flat Tip Screwdrivers | 1309-1312, 1338 |
| Floodlights | 1528 |
| Funnels, Clean | 994 |
| Garden Spades | 366 |
| Glue, Sticks | 1036, 1418 |
| Glue Guns | 1036, 1418 |
| Grease Guns | 996, 1017, 1309 |
| Grease Pumps | 1000 |
| Guns, Air | 1226, 1230 |
| Hacksaws, Frames | 1301, 1309-1312 |
| Halogen Lamps / Light Bulbs | 1528 |
| Hand Lamps | 1525 |
| Hand Stamps | 795, 1117 |
| Headlights, Hard Hat | 419 |
| Hex Keys | 1309-1312, 1346-1347 |
| Hold-Down Clamps | 1290 |
| Hose Reels | 1076, 1236-1237 |
| Hoses | |
| Air | 1207, 1233 |
| Lubricant | 996 |
| Impact Wrenches, Air | 1205 |
| Knives, Packaging | 1309, 1312, 1440 |
| Latch Clamps | 1290 |
| Lineman's Pliers | 1309-1312, 1348 |
| Locking Pliers | 1288, 1309-1312, 1352, 1354 |
| Long Nose Pliers | 1309-1312, 1348 |
| Mallets | 1309, 1311, 1362-1363 |
| Measuring Cups | 994 |
| Measuring Tape, Retractable Blade | 1277, 1309-1312 |
| Micrometers, Digital | 1275 |
| Multi-Purpose Hand Tools | 1355 |
| Nose Cutting Pliers | 1353 |
| Oil Cans | 999 |
| Orbital Sanders, Air | 1207 |
| Paint Supplies, Brushes | 1047 |
| Parallel Clamps | 1287 |
| Pin Punches | 1309-1310, 1312, 1368, 1370 |
| Pipe Fittings, Lubrication | 1000 |
| Power Strips, GFCI | 1541 |
| Pry Bars, Multi-Purpose | 1309-1312, 1366 |
| Quick Couplers | 1207, 1233 |
| Rakes | 367 |
| Ratchet Wrenches, Air | 1206 |
| Ratchets | |
| 1/2" Drive | 1317-1318, 1320 |
| 1/4" Drive | 1317 |
| 3/8" Drive | 1318 |
| Round Point Shovels | 366 |
| Scalers, Air | 1207 |
| Scaling Chisels | 1088 |
| Screwdrivers | |
| Air | 1207 |
| Sets | 1338 |
| Sealing Spatula | 1052 |
| Sets, Pliers | 1354 |
| Sledge Hammers, Non-Sparking | 369, 1365 |
| Slip Joint Pliers | 1309-1312, 1348 |
| Small Parts Cases | 36 |
| Snow Shovels | 365 |
| Socket Accessories | 1317-1318, 1320 |
| Socket Sets, Standard | 1309-1310, 1312-1314 |
| Sockets, Standard | 1317-1318, 1320 |
| Sprayers, Lawn & Garden | 320, 371 |
| Square Point Shovels | 366, 368 |
| Square Screwdrivers | 1309-1312, 1338 |
| Staples, Office Staplers | 1446 |
| Straight Line Clamps | 1290 |
| Surface Conditioning Pads | 933 |
| Technicians' Tools | 1309-1312 |
| Telescopic Lights | 1528 |
| Toggle Clamps | 1290 |
| Tongue & Groove Pliers | 1309-1312, 1348 |

| | |
|-------------------------------|----------------------|
| Tool Storage | |
| Boxes | 1309-1311, 1394 |
| Cabinets | 1309, 1312, 1395 |
| Carts | 1395 |
| Chests | 1309-1310, 1394-1395 |
| Jobsite Boxes | 36, 1394 |
| Tree Trimmers | 369 |
| Trigger Sprayers | 302, 320 |
| Utility Knives | 1440 |
| Vacuums | |
| Accessories | 352-353 |
| Wet / Dry | 352-353 |
| Wrecking Bars | 1366 |
| Wrenches, Pipe | 1309, 1373 |

AVERY DENNISON

| | |
|-------------------------|-----------|
| Cable Ties | 794, 1452 |
|-------------------------|-----------|

AVMOR

| | |
|-----------------------------|-----|
| Drain Cleaners | 316 |
|-----------------------------|-----|

AYLING & REICHERT

| | |
|--------------------------|-----|
| Pumps, Drum | 255 |
|--------------------------|-----|

BACHARACH

| | |
|--|-----|
| Combustible Gas Detectors | 487 |
|--|-----|

BAFFIN TECHNOLOGY

| | |
|---------------------------|---------|
| Knee Boots | 632 |
| Winter Boots | 635-636 |

BALDOR

| | |
|-----------------------------|------|
| Bench Grinders | 1270 |
|-----------------------------|------|

BASCO

| | |
|-------------------------------|-----|
| Scoops, Aluminum | 994 |
|-------------------------------|-----|

BATTERY EQUALISER

| | |
|---------------------------------|------|
| Battery Equalizers | 1037 |
|---------------------------------|------|

BEGHELLI

| | |
|-------------------------------|-----------|
| Batteries | |
| 12 Volt | 1522 |
| 6 Volt | 1522 |
| Emergency Lights | 1521-1522 |
| Exit Lights | 1521 |

BELLE-PAK

| | |
|-------------------------------------|------|
| Packing List Envelopes | 1449 |
|-------------------------------------|------|

BEN-MOR

| | |
|--------------------------------|---------|
| Aircraft Cables | 194 |
| Clevis Grab Hooks | 192 |
| Eye Bolts | 194 |
| Lifters, Drum | 243 |
| Slings | |
| Chain | 189 |
| Polyester | 188-189 |
| Slip Hooks | 192 |

BERNARD

| | |
|--------------------------------------|------------|
| Contact Tips, MIG Gun | 1094, 1098 |
| Diffusers, MIG Gun | 1098 |
| Electrode Holders | 1084 |
| Insulator Caps, MIG Gun | 1098 |
| Nozzles, MIG Gun | 1098 |

BERNZOMATIC

| | |
|-----------------------------|------|
| Butane Torches | 1083 |
|-----------------------------|------|

BESSEY

| | |
|---------------------------------|-----------|
| Angle Clamps | 1285 |
| Bar Clamps | 1284-1286 |
| Bench Vises | 1293 |
| Edge-Gluing Clamps | 1288 |
| Hold-Down Clamps | 1290 |
| L-Clamps | 1284 |
| Parallel Clamps | 1286 |
| Quick Clamps | 1288 |
| Snips, All Purpose | 1358 |

BIO CIRCLE

| | |
|------------------------------------|------------|
| Anti-Spatter | 1147 |
| Food Grade Degreasers | 1004 |
| Rust Preventers | 1014, 1146 |

BIOS

| | |
|--|-----------------|
| Bench Scales | 1491-1492, 1494 |
| Confined Space Signs | 758 |
| Cooking Thermometers | 1471, 1473 |
| Crutches, First Aid | 758 |
| Digital Thermometers | 1472 |
| Hanging Scales | 1494 |
| Indoor / Outdoor Thermometers | 1472 |
| Oral Thermometers | 756 |
| Stem Thermometers | 1473 |
| Step Ladder Hand Truck | 1581 |
| Stopwatches | 1483 |
| Thermocouple Probes | 1471 |
| Thermometer / Hygrometers | 1472 |
| Timers, Digital | 1483 |
| Wheel Chair | 758 |

BISHAMON

| | |
|--------------------------|----------|
| Lift Tables | 179, 181 |
|--------------------------|----------|

BLACK DIAMOND

| | |
|-----------------------------------|---------|
| Berms, Spill Control | 714 |
| Drum Equipment | |
| Spill Pallets | 713-714 |
| Trays | 713 |
| Salvage Drums | 713 |

BLICKLÉ

| | |
|--------------------------------|-----|
| Casters | 229 |
| Floor Lock Brakes | 231 |
| Wheels | 232 |

BOBRICK

| | |
|------------------------------|-----|
| Clothes Hooks | 350 |
| Soap Dispensers | 326 |

BODHUS

| | |
|-----------------------|----------|
| Hex Keys | 81, 1347 |
|-----------------------|----------|

BOOT-BOY

| | |
|---------------------------------------|-----|
| Boot & Shoe Cleaners | 889 |
|---------------------------------------|-----|

BRADLEY

| | |
|------------------------------------|---------|
| Drench Hoses | 726 |
| Emergency Showers | 718-719 |
| Eyewash, Water Heater | 721 |

BRAND INDEX

| | |
|-----------------------------------|----------|
| Eyewash Stations | |
| Faucet Mounted..... | 720 |
| Pedestal Mounted..... | 717 |
| Self Contained..... | 722-723 |
| Sink Mounted..... | 720 |
| Wall Mounted..... | 716, 720 |
| Lockers, Plastic | 109 |
| Privacy Shower Curtain | 727 |
| Shower Testers | 726 |
| Soap Dispensers | 326 |
| Thermostatic Mixing Valves | 721 |

BRADY

| | |
|------------------------------|------------------|
| Aisle Marking Tape | 869 |
| Ball Valve Lockouts | 783 |
| Barricade Tape | 868 |
| Disposable Dust Masks | 453 |
| Ear Plugs, Dispensers | 431 |
| Exit Signs | 811 |
| Flagging Tape | 869 |
| Glasses, Safety | 407 |
| Gloves, Dispensers | 600 |
| Glow in the Dark Tape | 811 |
| Label Makers | |
| Accessories..... | 825, 827-828 |
| Portable..... | 824-825, 827 |
| Ribbons..... | 824-828, 830 |
| Table Top Versions..... | 828 |
| Tapes..... | 825-826, 828-830 |
| Lockouts | |
| Kits..... | 777 |
| Stations..... | 772 |
| Vinyl Tape | 829 |
| WHMIS | |
| Labels..... | 846 |
| Wallet Cards..... | 846 |

BRK ELECTRONICS

| | |
|---|-----|
| Fire Protection, Fire Alarm Protectors | 655 |
|---|-----|

BROTHER

| | |
|-------------------------|-----------|
| Label Makers | |
| Portable..... | 1572-1573 |
| Ribbons..... | 1573 |
| Table Top Versions..... | 1572-1573 |
| Tapes..... | 1572-1573 |

BUCAN

| | |
|----------------|-----|
| Heaters | |
| Drum..... | 237 |
| Pail..... | 237 |

BULMAN

| | |
|----------------------|------|
| Paper Cutters | 1432 |
|----------------------|------|

BULWARK

| | |
|---------------------------|---------|
| Arc Flash Clothing | |
| Coveralls..... | 554-555 |
| Jackets..... | 555 |
| Overalls..... | 555 |
| Pants..... | 554 |
| Shirts..... | 554 |
| Coveralls, Work | 554 |
| Parkas | 555 |

BW TECHNOLOGIES BY HONEYWELL

| | |
|----------------------------|---------|
| Docking Stations | 482-483 |
| Gas Detectors | |
| Calibration Gas..... | 484 |
| Sensor..... | 484 |
| Multi-Gas Detectors | 482-484 |

| | |
|-----------------------------------|-----|
| Regulator, Calibration Gas | 484 |
| Single-Gas Detectors | 482 |

C.H. HANSON

| | |
|-----------------------------|---------|
| Barricade Tape | 868 |
| Beaded Chain | 794 |
| Blank Tags | 793 |
| Chain, Crowd Control | 794 |
| Flagging Tape | 869 |
| Hand Stamps | 795-796 |
| Ink Stencils | 797 |
| Key Rings | 794 |
| Locking Pliers | 1352 |
| Marking Flags | 871 |
| Numbered Tags | 793 |
| Paint Stencils | 798 |
| Seals | |
| Sealing Press..... | 794 |
| Security..... | 794 |

C.R. DANIELS INC.

| | |
|----------------------|-----|
| Hampers | 303 |
| Ironer Trucks | 303 |
| Linen Trucks | 303 |

CALDWELL

| | |
|----------------------|-----|
| Lifters, Drum | 238 |
|----------------------|-----|

CAMFIL FARR

| | |
|--------------------|------|
| Air Filters | 1506 |
|--------------------|------|

CAMPBELL

| | |
|--------------------------|-----|
| Clamps, Lifting | 198 |
| Clevis Grab Hooks | 192 |
| Hooks, Lifting | 192 |

CANABLAST

| | |
|--|-----------|
| Dust Collectors, Sandblasting | 1056 |
| Guns, Sandblasting | 1057 |
| Media, Sandblasting | 1055 |
| Media Recyclers, Sandblasting | 1056 |
| Portable Blasters, Sandblasting | 1057 |
| Suction Cabinets | 1056-1057 |

CANADIAN MAILBOX COMPANY

| | |
|------------------|------|
| Mailboxes | 1576 |
|------------------|------|

CANARM

| | |
|-----------------------|------|
| Smoke Ejectors | 1501 |
|-----------------------|------|

CANON

| | |
|---|------|
| Paper, Printer & Photocopier | 1579 |
|---|------|

CAP CANADA DISTRIBUTION INC.

| | |
|-------------------|-----|
| Absorbents | 684 |
|-------------------|-----|

CARDINAL CORRUGATED CONTAINERS

| | |
|-------------------------------------|----|
| Small Parts Bins, Fiberboard | 11 |
|-------------------------------------|----|

CARGOLOC

| | |
|---------------------|-----------|
| Bungee Cords | 1455 |
| Cargo Nets | 1455 |
| Tie-Downs | 1455-1456 |

CASCADES

| | |
|--------------------------------|--------------------|
| Facial Tissue | 344 |
| Hand Towels | 340-342, 344, 1583 |
| Napkin Dispensers | 343-344, 1583 |
| Napkins, Cafeteria | 343-344, 1583 |
| Paper Towel Dispensers | 340-342, 1583 |
| Paper Towels | 344 |
| Toilet Paper | 340, 345-346 |
| Toilet Paper Dispensers | 345, 347 |
| Wipes | 336, 384 |
| Wipes Dispensers | 336, 340 |

CAULK MASTER

| | |
|----------------------|------|
| Caulking Guns | 1024 |
|----------------------|------|

CCI CANADA

| | |
|--------------------------------------|---------|
| Channelizers, Traffic Control | 864 |
| Cones | |
| Safety..... | 308 |
| Traffic Control..... | 862 |
| Delineators, Traffic Control | 863-864 |
| Flashing Lights | 866 |

CENTENNIAL

| | |
|--------------------|-----|
| Racks, Drum | 245 |
|--------------------|-----|

CERTAINTY WIPES

| | |
|-------------------------|-----|
| Wipes Dispensers | 334 |
|-------------------------|-----|

CHAPIN

| | |
|------------------------------------|--------------|
| Sprayers, Lawn & Garden | 320, 371-372 |
|------------------------------------|--------------|

CHECKERS INDUSTRIAL PRODUCTS

| | |
|-------------------------------|-----|
| Cable Protectors, Dock | 217 |
| Wheel Chocks | 211 |

CHEMETALL

| | |
|-----------------------------------|------|
| Non-Aqueous Developers | 1144 |
| Non-Chlorinated Degreasers | 1144 |
| Penetrants, Water Based | 1144 |

CHEMOTEC

| | |
|---------------------------------|-----|
| Dish Detergents | 316 |
| Floor Cleaners | 310 |
| Floor Finishes | 311 |
| Floor Sealers | 311 |
| Floor Stripper | 311 |
| Hand Cleaners, Lotion | 326 |
| Oven Cleaners | 316 |
| Stainless Steel Cleaners | 316 |
| Toilet Bowl Cleaners | 314 |

CHICAGO PNEUMATIC

| | |
|--------------------------------|------------------|
| Angle Grinders, Air | 1211, 1215 |
| Automotive Stands | 207 |
| Belt Sanders, Air | 1213 |
| Bottle Jacks | 206 |
| Chippers, Air | 1213 |
| Die Grinders, Air | 1212, 1215 |
| Drills, Air | 1209 |
| Engravers, Air | 1212 |
| Garage Jacks | 206 |
| Hammers, Air | 1213 |
| Impact Wrenches, Air | 1208, 1210, 1214 |
| In-Line Drills, Air | 1209 |
| Mini Die Grinders, Air | 1215 |
| Orbital Sanders, Air | 1211-1212 |
| Ratchet Wrenches, Air | 1210 |
| Reciprocating Saws, Air | 1214 |
| Rotary Sanders, Air | 1211 |

| | |
|------------------------|------------|
| Scalers, Air..... | 1214 |
| Screwdrivers, Air..... | 1209, 1211 |
| Shears, Air..... | 1214 |

CI CALSTONE INC.

| | |
|-------------------------|-----------------|
| Bench Scales..... | 1433 |
| Casters..... | 1433 |
| Packaging, Benches..... | 1433 |
| Paper Cutters..... | 1427, 1432-1433 |
| Shipping, Benches..... | 1433 |

CIMCO

| | |
|------------------------------------|-----------|
| Combination Slip-Joint Pliers..... | 1377 |
| Hex Wrenches..... | 1378 |
| Insulated Cutters..... | 1377 |
| Snipe Nose Pliers..... | 1377 |
| Technicians' Tools..... | 1378-1379 |

CIMCOOL

| | |
|------------------------|------|
| Tapping Compounds..... | 1149 |
|------------------------|------|

CK WORLDWIDE INC

| | |
|--------------------------------------|-----------------|
| Air (Gas) Cooled Torches..... | 1101, 1103-1104 |
| Alumina Nozzles..... | 1106 |
| Back Caps, TIG Torch..... | 1108 |
| Collet Bodies, TIG Torch..... | 1107-1109 |
| Collets, TIG Torch..... | 1107 |
| Fuse Blocks, TIG Torch..... | 1110 |
| Gas Hoses, Welding..... | 1110 |
| Lava Nozzles..... | 1105 |
| Power Cable Adapters, TIG Torch..... | 1109 |
| Power Cables, TIG Torch..... | 1110 |
| TIG Welders..... | 1113 |
| Torch Kits, Welding..... | 1109 |
| Tungsten Electrode Grinders..... | 1113-1114 |
| Tungsten Electrodes..... | 1114 |
| Water Cooled Torches..... | 1103-1104 |
| Water Hoses, Welding..... | 1110 |

CLARKSON OSBORN

| | |
|----------------------------------|-------------------|
| Adjustable Reamers..... | 985 |
| Annular Cutters..... | 972, 1193 |
| Burs, Carbide..... | 990-991, 1215 |
| Chucking Reamers | |
| Cobalt..... | 985 |
| HSS..... | 981-985 |
| Circular Split Dies..... | 978, 980 |
| Dies, Die Stocks..... | 977 |
| Drill Bits | |
| Aircraft Extension..... | 968, 972 |
| Jobber..... | 963-967 |
| Spiral Flute..... | 972 |
| Straight Shank..... | 971 |
| Taper Length..... | 969 |
| Taper Shank..... | 971 |
| End Mills | |
| Carbide..... | 988-989 |
| HSCo..... | 986-987 |
| HSS..... | 986 |
| Weldon Shank..... | 986 |
| Hand Reamers..... | 981 |
| Hand Taps..... | 974-975, 977, 988 |
| Hexagonal Dies..... | 978-979 |
| Machine Taps..... | 976 |
| Pipe Taps..... | 973 |
| Prentice Drill Bits..... | 969-970 |
| Screw Extractors..... | 989 |
| Tap & Drill Sets..... | 973 |
| Tap Wrenches..... | 977 |
| Taper Pin Reamers..... | 982 |
| Tool Holders, Turning Tools..... | 986 |

CLECO

| | |
|---------------------------|------|
| Impact Wrenches, Air..... | 1222 |
| In-Line Drills, Air..... | 1221 |
| Screwdrivers, Air..... | 1222 |

CLOROX

| | |
|------------|----------|
| Wipes..... | 318, 759 |
|------------|----------|

CM INDUSTRIES

| | |
|--------------------|---------|
| Beam Clamps..... | 199 |
| Beam Trolleys..... | 190 |
| Hoists | |
| Air..... | 191 |
| Electric..... | 191 |
| Manual..... | 190-191 |

COGAN

| | |
|------------------|----|
| Guard Rails..... | 84 |
|------------------|----|

COLSON

| | |
|------------------------|---------|
| Casters..... | 230-231 |
| Floor Lock Brakes..... | 231 |

CONTOUR

| | |
|---------------------------|-----------|
| Burning Guides..... | 1117 |
| Pipe Contour Markers..... | 1116-1117 |
| Pipe Flange Aligners..... | 1116 |
| Pipefitting Levels..... | 1116-1117 |

COOLWORKS

| | |
|--------------------------------------|-----|
| High Visibility Clothing, Pants..... | 551 |
|--------------------------------------|-----|

COOPER INDUSTRIES INC

| | |
|------------------------------|------|
| Plugs, Electrical..... | 1084 |
| Receptacles, Electrical..... | 1084 |

CORDEX

| | |
|-----------------------|-----------|
| Buckles | |
| Plastic..... | 1421-1422 |
| Poly..... | 1422 |
| Steel..... | 1421 |
| Seals, Steel..... | 1421 |
| Strapping | |
| Dispensers..... | 1422 |
| Machines & Tools..... | 1419 |
| Poly..... | 1422 |

CORNER EDGE

| | |
|----------------------|----------|
| Edge Protectors..... | 48, 1423 |
|----------------------|----------|

CRAMER

| | |
|------------------|-----|
| Stepladders..... | 135 |
|------------------|-----|

CRC CANADA

| | |
|--|-----------------|
| Air Tool Oil..... | 1261 |
| Automotive Cleaners, Diesel Conditioner..... | 1015 |
| Battery Cleaners..... | 1015 |
| Brake Cleaners..... | 1015 |
| Carburetor Cleaner..... | 1015 |
| Contact Cleaners..... | 1006 |
| Degreasers, Heavy-Duty..... | 1002-1003, 1005 |
| De-Icer..... | 1015 |
| Dry Lubricants, Graphite..... | 1008 |
| Food Grade Degreasers..... | 1003 |
| Freeze Spray..... | 1006 |
| Lubricants, General Purpose..... | 1013 |
| Paint, Rubber..... | 1015 |
| Parts Washers..... | 995 |

| | |
|-----------------------|------|
| Rust Converters..... | 1014 |
| Spray Lubricants..... | 1008 |

CRESCENT

| | |
|------------------------------|------|
| Adjustable Wrenches..... | 1332 |
| Pry Bars, Multi-Purpose..... | 1366 |

CREWS

| | |
|------------------|-----|
| Faceshields..... | 412 |
|------------------|-----|

CROSBY

| | |
|----------------------|-----|
| Beam Clamps..... | 199 |
| Clamps, Lifting..... | 198 |

CROWN-MEAKINS

| | |
|-------------------------|-----------|
| Paint Supplies | |
| Brushes..... | 1047-1049 |
| Roller Covers..... | 1049-1051 |
| Rollers..... | 1051 |
| Sponging & Ragging..... | 1050 |

DAINOLITE LTD

| | |
|---------------------------------------|------------|
| Desk Lamps..... | 1524, 1582 |
| Fluorescent Lamps / Light Bulbs..... | 1524, 1582 |
| Halogen Lamps / Light Bulbs..... | 1524, 1582 |
| Incandescent Lamps / Light Bulbs..... | 1582 |
| Magnifiers | |
| Illuminated..... | 1524 |
| Lenses..... | 1524 |
| Wall Clocks..... | 1575 |

DAKOTA

| | |
|-----------------------|------|
| Thickness Gauges..... | 1479 |
|-----------------------|------|

DANBY

| | |
|--------------------|------|
| Refrigerators..... | 1584 |
|--------------------|------|

DBI SALA

| | |
|---|-------------------|
| Anchorage Connectors..... | 517 |
| Beam Clamp Anchors..... | 517 |
| Carabiners..... | 516 |
| Davits..... | 490 |
| D-Bolt Anchors..... | 516 |
| D-Ring Harnesses..... | 495 |
| Fall Protection, Harnesses..... | 141, 494-495 |
| Friction Bolt Anchors..... | 516 |
| Hard Hat Lanyards..... | 524 |
| Positioning and Restraint Lanyards..... | 508 |
| Rescue Systems..... | 491-492, 496, 518 |
| Rope Grabs..... | 517-518 |
| Self-Retracting Lanyards..... | 492, 512 |
| Self-Retracting Life Lines..... | 492, 512, 518 |
| Shock Absorbing Lanyards..... | 141, 507 |
| Tool Lanyards..... | 524 |
| Vertical Life Lines..... | 517 |
| Winches, Personal..... | 492 |

DEB STOKO

| | |
|----------------------------|---------|
| Hand Cleaners, Lotion..... | 332 |
| Hand Creams..... | 331 |
| Hand Sanitizers..... | 333 |
| Shampoo..... | 325 |
| Skin Conditioners..... | 333 |
| Soap Dispensers..... | 331-332 |
| Sunscreen..... | 335 |
| Wipes..... | 334 |

DECADE

| | |
|--------------------|-----|
| Back Supports..... | 642 |
|--------------------|-----|

BRAND INDEX

DEFELSKO

| | |
|-------------------------|------|
| Porosity Detectors..... | 1478 |
| Thickness Gauges..... | 1478 |

DEFENDER

| | |
|------------------|------|
| Task Lights..... | 1529 |
|------------------|------|

DELMHORST INSTRUMENT CO.

| | |
|----------------------|------|
| Moisture Meters..... | 1477 |
|----------------------|------|

DENTEC

| | |
|--------------------------|-----|
| Eyewash Stations | |
| Bottled..... | 724 |
| Water Preservatives..... | 722 |
| Foot Warmers..... | 636 |
| Hand Warmers..... | 629 |

DE-STA-CO

| | |
|---------------------------|-----------|
| Hold-Down Clamps..... | 1291-1292 |
| Latch Clamps..... | 1291-1292 |
| Straight Line Clamps..... | 1292 |
| Toggle Clamps..... | 1291 |

DEWALT

| | |
|------------------------------------|----------------------------------|
| Angle Drills, Electric..... | 1184 |
| Angle Grinders, Electric..... | 1168-1171 |
| Bandsaws, Wood Cutting..... | 1178 |
| Battery Chargers..... | 1167 |
| Bench Grinders..... | 1270 |
| Caulking Guns..... | 1161 |
| Chop Saws..... | 1174 |
| Circular Saws, Heavy-Duty..... | 1177 |
| Combo Kits..... | 1164-1166 |
| Compressors, Air..... | 1262 |
| Cordless Power Tool Batteries..... | 1157-1158, 1160-1161, 1164, 1167 |
| D Handle Drills..... | 1183 |
| Demolition Hammers..... | 1187 |
| Die Grinders, Electric..... | 1172 |
| Drills | |
| Drill / Drivers..... | 1182 |
| Drill / Drivers - Cordless..... | 1157, 1161 |
| Hammer Drill / Drivers..... | 1158 |
| Hammer Drills..... | 1184-1185 |
| Hand Powered Drills..... | 1182-1183 |
| Impact Wrenches | |
| Cordless..... | 1160 |
| Electric..... | 1181 |
| Jig Saws, Heavy-Duty..... | 1178 |
| Laser Levels..... | 1283 |
| Mitre Saws..... | 1175-1176 |
| Nail Guns, Cordless..... | 1163 |
| Palm Sanders..... | 1180 |
| Plumb Bobs..... | 1283 |
| Reciprocating Saws, Electric..... | 1179 |
| Rotary Hammers..... | 1185-1186 |
| Screw Guns..... | 1187 |
| Shears, Power..... | 1173 |

DIMAR

| | |
|-----------------------------|------|
| Circular Saw Blades..... | 1203 |
| Combination Saw Blades..... | 1203 |
| Cut-Off Blades..... | 1203 |
| Forstner Bits..... | 1200 |
| Mitre Saw Blades..... | 1203 |

DIVERSIFIED PLASTICS INC.

| | |
|-------------------------------|-----|
| Column Protectors..... | 86 |
| Stepstools, Polyethylene..... | 136 |

DORMER

| | |
|-------------------------------------|----------|
| Combined Drills & Countersinks..... | 961 |
| Countersinks..... | 962 |
| Drill Bits, Jobber..... | 948, 952 |
| Hand Taps..... | 957-960 |
| Pipe Taps..... | 960 |

DOTCO

| | |
|---------------------------|------|
| Angle Drills, Air..... | 1222 |
| Angle Grinders, Air..... | 1222 |
| Die Grinders, Air..... | 1223 |
| Drills, Air..... | 1223 |
| Engravers, Air..... | 1223 |
| Pencil Grinders, Air..... | 1223 |

DREMEL

| | |
|-------------------|------|
| Dremel Tools..... | 1192 |
|-------------------|------|

DUPONT PERSONAL PROTECTION

| | |
|------------------------------------|----------|
| Aprons, General Protection..... | 534 |
| Boot Covers..... | 534 |
| Coveralls | |
| General Protection..... | 535-537 |
| Limited Use..... | 537 |
| Hoods, General Protection..... | 534 |
| Lab Coats, General Protection..... | 534, 536 |
| Pants, General Protection..... | 534 |
| Shirts, General Protection..... | 534 |
| Sleeves, Polypropylene..... | 534 |

DURATRACK

| | |
|--------------------------|--------|
| Strip Curtain Doors..... | 91, 93 |
|--------------------------|--------|

DURHAM MANUFACTURING

| | |
|---------------------------|-------------------|
| Cabinet Drawers..... | 37 |
| Literature Displays..... | 1568 |
| Mail Sorters..... | 1566 |
| Parts Storage Carts..... | 42 |
| Revolving Bins..... | 29 |
| Small Parts Cabinets..... | 33, 37, 42-43, 45 |
| Small Parts Cases..... | 36 |
| Threaded Rod Racks..... | 45 |
| Wire Spool Carts..... | 167 |
| Workbenches..... | 125 |

DUSTBANE

| | |
|---|---------------|
| Carpet Cleaners..... | 317 |
| Degreasers, Heavy-Duty..... | 313 |
| Dilution Dispenser..... | 313 |
| Disinfectants..... | 313, 318, 759 |
| Environmental Cleaners..... | 317-318 |
| Floor Cleaners..... | 311 |
| Floor Finishes..... | 362 |
| Floor Sealers..... | 362 |
| Floor Stripper..... | 362 |
| Glass Cleaners..... | 315 |
| Hand Cleaners, Lotion..... | 315 |
| Industrial Cleaners, Multi-Purpose..... | 313-314 |
| Machine Cleaners, Heavy-Duty..... | 320 |
| Solvent Free Degreasers..... | 313 |
| Sweeping Compounds..... | 290 |
| Vacuums, Wet / Dry..... | 360 |

DWYER

| | |
|-----------------------|------|
| Ball Valves..... | 1231 |
| Butterfly Valves..... | 1231 |
| Manometers..... | 1488 |

DYKEM

| | |
|-------------------------------|------|
| Paint Markers..... | 1442 |
| Tamper Proof Torque Mark..... | 1342 |

DYMO

| | |
|---------------|------|
| Label Makers | |
| Portable..... | 1574 |
| Software..... | 1574 |
| Tapes..... | 1574 |

DYNABRADE

| | |
|---------------------------|----------------------|
| Belt Sanders, Air..... | 1216-1217, 1220-1221 |
| Buffers, Air..... | 1221 |
| Die Grinders, Air..... | 1220 |
| Orbital Sanders, Air..... | 1218-1219 |
| Swivel Connectors..... | 1219, 1250 |

DYNAFLUX QUALITY PRODUCTS

| | |
|----------------------------------|------|
| Aluminum Cleaners..... | 1145 |
| Anti-Spatter..... | 1145 |
| Galvanizing Compounds..... | 1144 |
| Layout Fluids..... | 1145 |
| Nozzle Gels, MIG Gun..... | 1145 |
| Pump Lubricants..... | 1144 |
| Tungsten Electrode Grinders..... | 1114 |

DYNALINE

| | |
|----------------------------|----------|
| Funnels, Polyethylene..... | 317, 994 |
|----------------------------|----------|

EAGLE MFG.

| | |
|------------------------|---------|
| Column Protectors..... | 86 |
| Edge Protectors..... | 86, 216 |

E-A-R

| | |
|--------------------|---------|
| Ear Plugs | |
| Corded..... | 426 |
| Dispensers..... | 427 |
| Disposable..... | 424-427 |
| Reusable..... | 428-429 |
| Uncorded..... | 426 |
| Hearing Bands..... | 430-431 |

ECHO

| | |
|------------------------------|-----|
| Sprayers, Lawn & Garden..... | 371 |
|------------------------------|-----|

EDGE SAFETY EYEWEAR

| | |
|-------------|---------|
| Glasses | |
| Cases..... | 407 |
| Safety..... | 402-403 |

EDSAL

| | |
|-------------------------------|---------------|
| Bookcases..... | 1567 |
| Cabinet Tables..... | 124 |
| Cabinets, Storage..... | 98, 103, 1561 |
| Computer Cabinets..... | 1559-1560 |
| Filing Cabinets, Lateral..... | 1563 |
| Service Writers..... | 126 |
| Shelving Units | |
| Chrome..... | 56 |
| Steel..... | 55-56, 58 |
| Shop Desks..... | 126 |
| Tool Storage | |
| Cabinets..... | 103 |
| Carts..... | 124 |
| Workbenches..... | 120, 125 |

ELMER'S

| | |
|-----------------------------|------|
| Carpenters' Glue..... | 1029 |
| Construction Adhesives..... | 1029 |
| Contact Cement..... | 1029 |
| Pencil Sharpeners..... | 1578 |
| White Glue..... | 1029 |
| Wood Glue..... | 1029 |

ELWOOD PACKAGING

| | |
|-----------------------------|----------|
| Boxes, Mailers | 1434 |
| Cones, Pallet | 48, 1423 |

ENERGIZER

| | |
|-----------------------------------|------------|
| Batteries | |
| 1.5 Volt..... | 1507 |
| 12 Volt..... | 1507 |
| 3 Volt..... | 1507 |
| 6 Volt..... | 1507 |
| 9 Volt..... | 1507 |
| AA Cell..... | 1507, |
| AAA Cell..... | 1507, |
| C Cell..... | 1507, |
| D Cell..... | 1507, |
| Battery Chargers | 1507 |
| Flashlights | |
| AA Cell..... | 1517, 1519 |
| Mini..... | 1519 |
| Rechargeable..... | 1519 |
| Waterproof..... | 1517 |
| Headlights, Hard Hat | 419 |
| Lanterns, 6 V | 1517 |

ENERVAC

| | |
|---------------------------------|-----|
| Vacuums, Wet / Dry | 360 |
|---------------------------------|-----|

ENPAC

| | |
|--|---------------|
| Absorbents | 685 |
| Berms, Spill Control | 711-712 |
| Containers, Spill Control | 709-710 |
| Covers, Drum | 699 |
| Dollies | |
| Drum..... | 701-702 |
| Gas Cylinder..... | 1078 |
| Drip Pans | 681 |
| Drum Equipment | |
| Carts..... | 701 |
| Racks..... | 703 |
| Spill Pallets..... | 704-705, 710 |
| Trays..... | 681, 703, 711 |
| Funnels, Spill Control | 699 |
| Gas Cylinder | |
| Brackets..... | 1079 |
| Racks..... | 1079 |
| Stands..... | 1079 |
| Leak Diverters | 683 |
| Pail Funnels | 699 |
| Pools, Spill Control | 711 |
| Salvage Drums | 700-702 |
| Stackers | 703 |

ERB SAFETY

| | |
|------------------------|---------|
| Bump Caps | 415 |
| Hard Hats | 414-415 |

ERGODYNE

| | |
|---|----------|
| Anti-Vibration Gloves | 607 |
| Back Supports | 641-642 |
| Balaclavas | 553 |
| Coats, Winter | 552 |
| Ergonomic Products, Gloves | 603 |
| Folding Chairs | 382 |
| Glasses, Cord Retainers | 408 |
| Gloves, Holders | 629 |
| Hard Hat Lanyards | 420, 522 |
| Hard Hat Liners, Cooling | 646 |
| Hats, Cooling | 645 |
| Headbands, Cooling | 645, 647 |
| Headlights, Hard Hat | 549 |
| Heat Resistant Gloves | 605 |
| Hydration Backpack | 647 |
| Impact Gloves | 605 |

| | |
|-----------------------------------|-----------------|
| Knee Pads | |
| Co-Polymer / Ester Tricot..... | 639 |
| Foam..... | 640 |
| Gel..... | 639-640 |
| Rubber..... | 640 |
| Kneeling Pads | 639 |
| Neck Shades, Cooling | 647 |
| Pants, Work | 552 |
| Tennis Elbow Braces | 643 |
| Tool Lanyards | 522-523 |
| Tool Storage | |
| Aprons..... | 1391 |
| Bags..... | 1392 |
| Holdings..... | 1392 |
| Pouches..... | 523, 1390, 1392 |
| Towels, Cooling | 645-646 |
| Undergarments | 552 |
| Undershirts | 552 |
| Vests, Cooling | 646 |
| Winter Lined Gloves | 604-605 |
| Winter Liners | 553 |
| Work Tents | 382, 647 |
| Wraps, Cooling | 645, 647 |
| Wrist Supports | 643-644 |

ESSELTE

| | |
|---------------------------|------------|
| File Folders | 1564, 1579 |
|---------------------------|------------|

EX-CELL

| | |
|-----------------------------|-----|
| Carts, Laundry | 303 |
|-----------------------------|-----|

EXPO ENGINEERING

| | |
|----------------|-----|
| Heaters | |
| Drum..... | 237 |
| Pail..... | 237 |

EXTREME TOOLS

| | |
|---------------------|-----------------|
| Tool Storage | |
| Cabinets..... | 1396-1400 |
| Carts..... | 125, 1397, 1400 |
| Chests..... | 1396-1399 |

FAIRVIEW FITTINGS

| | |
|-------------------------------------|------|
| Propane Hoses, Welding | 1068 |
| Regulators, Welding | 1068 |

FALCON SIGNAL HORNS

| | |
|---------------------------|-----|
| Signal Horns | 444 |
|---------------------------|-----|

FANTASTIK

| | |
|----------------------------|-----|
| Disinfectants | 314 |
|----------------------------|-----|

FEATHERLITE

| | |
|------------------------------------|-------------------|
| Double Stepladders | 129, 131 |
| Extension Ladders | 132-133 |
| Multi-Purpose Ladders | 131-132 |
| Platform Ladders | 127, 129-131, 135 |
| Single Ladders | 127, 132-133 |
| Stepladders | 127-128, 134 |
| Work Platforms | 135 |

FEDERAL SIGNAL CORPORATION

| | |
|------------------------------|---------|
| Flashing Lights | 222-223 |
| Horns | 221 |
| Megaphones | 444 |

FELLOWES

| | |
|------------------------------|------|
| Desk Organizers | 1577 |
| Filing Boxes | 1564 |

FELTON BRUSHES

| | |
|--------------------------------------|---------------|
| Cup Brushes | 945 |
| End Brushes | 940, 942, 944 |
| Paint Supplies, Brushes | 1046 |
| Scratch Brushes | 946-947 |
| Tube Brushes | 945 |
| Wheel Brushes | 942-944 |

FIBRE-METAL BY HONEYWELL

| | |
|---------------------------|----------|
| Face Shields | 410, 557 |
| Hard Hats | 417 |

FILL-RITE

| | |
|---------------------------|-----|
| Hand Pumps | 258 |
| Rotary Pumps | 258 |

FIRST

| | |
|-----------------------------------|-----|
| Fall Protection Kits | 507 |
|-----------------------------------|-----|

FIRST ALERT

| | |
|---------------------------------------|-----|
| Disposable Gloves | 656 |
| Smoke Alarms, Ionization | 655 |

FIRST SAFETY CORPORATION

| | |
|-----------------------------|------|
| Carts, Welding | 1078 |
| Gas Cylinder | |
| Brackets..... | 1079 |
| Trucks..... | 1078 |
| Racks, Welding | 1078 |

FLAMBEAU

| | |
|--------------------------------|----|
| Small Parts Cases | 36 |
|--------------------------------|----|

FLANGE WIZARD TOOLS

| | |
|----------------------------|------|
| Pocket Levels | 1115 |
|----------------------------|------|

FREUD

| | |
|----------------------------------|-----------|
| Circular Saw Blades | 1202-1203 |
|----------------------------------|-----------|

FROST

| | |
|---|-------------------|
| Ashtrays | 284-285 |
| Bathroom Mirrors | 350 |
| Bicycle Racks | 379 |
| Clothes Hooks | 350 |
| Floor Signs | 308 |
| Garbage Bags | 348-349 |
| Garbage Cans | 267, 270, 349-350 |
| Grab Bar | 350 |
| Hand Dryers | 351 |
| Hand Towels | 343 |
| Liners, Waste Container | 270 |
| Paper Towel Dispensers | 342-343 |
| Recycling Containers | 278 |
| Sanitary Napkin Dispensers | 348 |
| Sanitary Napkin Receptacles | 348 |
| Sanitary Napkins | 348 |
| Shelves, Washroom | 350 |
| Soap Dispensers | 326 |
| Tampons | 348 |
| Toilet Paper Dispensers | 347 |
| Toilet Seat Cover Dispensers | 348 |
| Toilet Seat Covers | 348 |

FULLER

| | |
|--|------|
| Anti-Vibration Hammers | 1364 |
| Ball Pein Hammers, Anti-Vibration | 1365 |
| Cabinet Tip Screwdrivers | 1340 |
| C-Clamps | 1289 |
| Claw Hammers | 1364 |

BRAND INDEX

| | |
|-------------------------------|------|
| Cross-Point Screwdrivers..... | 1340 |
| Curved Claw Hammers..... | 1364 |
| End Cutters..... | 1349 |
| Flat Tip Screwdrivers..... | 1340 |
| Knives, Packaging..... | 1441 |
| Precision Screwdrivers..... | 1341 |
| Pry Bars | |
| Multi-Purpose..... | 1366 |
| Tack Pullers..... | 1340 |
| Scratch AWL Screwdrivers..... | 1340 |
| Screwdrivers, Sets..... | 1340 |
| Spring Clamps..... | 1288 |
| Square Screwdrivers..... | 1340 |

FULTON

| | |
|-----------------------|-----|
| Hand Winches..... | 195 |
| Industrial Jacks..... | 207 |
| Marine Jacks..... | 207 |

GANTS LAURENTIDE

| | |
|----------------------------|-----|
| Heat Resistant Gloves..... | 624 |
|----------------------------|-----|

GARANT

| | |
|-----------------------------------|-----------|
| Axes, All-Purpose..... | 368 |
| Carpenter Axes..... | 368 |
| Club Hammers..... | 369, 1366 |
| Crowbars, Pitch Point..... | 368 |
| Cultivators..... | 368 |
| Garden Hose Hangers..... | 378 |
| Garden Spades..... | 366 |
| Grain and Coal Scoops..... | 366 |
| Hedge Shears..... | 369 |
| Hoes..... | 368 |
| Lopping Shears..... | 369 |
| Picks..... | 368 |
| Pry Bars, Nail Pullers..... | 1366 |
| Rakes..... | 367 |
| Round Point Shovels..... | 366 |
| Scoops, Aluminum..... | 366 |
| Sidewalk Scrapers..... | 368 |
| Sledge Hammers, Double Faced..... | 369, 1366 |
| Sleigh Shovels..... | 365 |
| Snow Brushes..... | 364 |
| Snow Shovels..... | 364-365 |
| Spading Forks..... | 367 |
| Square Point Shovels..... | 365-366 |
| Tree Pruners..... | 369 |
| Tree Trimmers..... | 369 |
| Turf Edgers..... | 368 |

GARDEX

| | |
|-----------------|------|
| Filing Cabinets | |
| Lateral..... | 1562 |
| Vertical..... | 1562 |
| Safes..... | 1562 |

GASFLUX

| | |
|-----------|------|
| Flux..... | 1145 |
|-----------|------|

GEARWRENCH

| | |
|-------------------------------|-----------|
| Combination Wrenches..... | 1333 |
| Sets..... | 1334 |
| Cross-Point Screwdrivers..... | 1341 |
| Flat Tip Screwdrivers..... | 1341 |
| Flex Head Wrenches..... | 1334 |
| Gear Wrenches, Sets..... | 1333-1334 |
| Hooks & Picks..... | 1307 |
| Impact Sockets..... | 1326 |
| Pry Bars, Multi-Purpose..... | 1366 |
| Ratcheting Wrenches..... | 1333-1334 |
| Screwdrivers, Sets..... | 1341 |
| Torque Wrenches..... | 1328 |
| Torx® Screwdrivers..... | 1341 |

GENERAL

| | |
|-----------------------------|-----------|
| Bevels..... | 1280-1281 |
| Center Punches..... | 1370 |
| Inspection Mirrors..... | 883 |
| Precision Screwdrivers..... | 1341 |

GENSTAR TECHNOLOGIES

| | |
|-----------------------------|-----------|
| Flowmeters, Welding..... | 1068 |
| Gas Cylinder, Wrenches..... | 1073 |
| Gas Hoses, Welding..... | 1075 |
| Gas Torches..... | 1064 |
| Heating Tips..... | 1072 |
| Outfits, Welding..... | 1063-1064 |
| Pressure Gauges, Dry..... | 1068 |
| Regulators, Welding..... | 1066-1067 |

GENTEC

| | |
|------------------------------------|-----------------|
| Gauge Protectors, Welding..... | 1067 |
| Heating Tips..... | 1072 |
| Outfits, Welding..... | 1063 |
| Regulator/Flowmeters, Welding..... | 1068 |
| Regulators, Welding..... | 1066-1067, 1069 |

GERBER

| | |
|-------------------------------|------|
| Multi-Purpose Hand Tools..... | 1355 |
| Pocket Knives..... | 1355 |

GERMIPHENE

| | |
|--------------------|---------------|
| Disinfectants..... | 318, 759 |
| Wipes..... | 318, 465, 759 |

GILMOUR

| | |
|------------------------|-----|
| Guns, Garden Hose..... | 376 |
|------------------------|-----|

GLADE

| | |
|---------------------|-----|
| Air Fresheners..... | 322 |
|---------------------|-----|

GLOBAL

| | |
|----------------------------------|------------|
| Bookcases..... | 1567 |
| Ergonomic Products, Seating..... | 1547-1548 |
| Filing Cabinets, Vertical..... | 1563 |
| Folding Tables..... | 382, 1557 |
| Monitor Mounts..... | 1558 |
| Office Desks..... | 1567 |
| Office Seating..... | 1549 |
| Stacking Chairs..... | 1555 |
| Stacking Tables..... | 1556-1557 |
| Task Seating..... | 1552 |
| Work Tables..... | 1556, 1561 |

GOJO

| | |
|------------------------|---------------|
| Cream Dispensers..... | 331 |
| Hand Cleaners | |
| Cream..... | 331 |
| Foam..... | 325, 329 |
| Gel..... | 328 |
| Liquid..... | 331 |
| Lotion..... | 326-329 |
| Hand Towels..... | 334, 384 |
| Shampoo..... | 329 |
| Skin Conditioners..... | 333 |
| Skin Creams..... | 333 |
| Soap Dispensers..... | 325, 330, 333 |

GOODWRAPPERS

| | |
|------------------------------|-----------|
| Stretch Wrap | |
| Banding Film..... | 1425 |
| Cast..... | 1424 |
| Clear..... | 1425 |
| Coloured..... | 1424 |
| Opaque..... | 1424 |
| Stretch Wrap Dispensers..... | 1424-1425 |

GOSS

| | |
|--------------------------|-----------|
| Cutting Tips..... | 1070-1072 |
| Heating Tips..... | 1072 |
| Propane Torches..... | 1064 |
| Regulators, Welding..... | 1064 |
| Soldering Tips..... | 1064 |
| Torch Kits, Welding..... | 1064 |

GREE

| | |
|-----------------------|------|
| Air Conditioners..... | 1500 |
| Humidifiers..... | 1500 |

GREENLEE

| | |
|----------------------|------|
| Bar Racks..... | 53 |
| Circuit Testers..... | 1539 |

GREIF

| | |
|--------------------------|-----|
| Drums, Polyethylene..... | 234 |
|--------------------------|-----|

GUARDAIR

| | |
|------------------------------|-----------|
| Guns, Air..... | 1228-1229 |
| Pneumatic Pipe Fittings..... | 1228 |
| Vacuums, Accessories..... | 1225 |

GW METAL

| | |
|-------------------|----------|
| Garbage Cans..... | 272, 383 |
|-------------------|----------|

H.K. PORTER

| | |
|--------------------------------------|------------|
| Bolt Cutters..... | 1360-1361 |
| Cable Cutters, Industrial Grade..... | 1085, 1361 |
| Iron Shear Cutters..... | 1361 |
| Rebar Cutters..... | 1361 |

HANG-A-LIGHT

| | |
|---------------------------------|------|
| H.I.D. Lamps / Light Bulbs..... | 1530 |
| Task Lights..... | 1530 |

HANNAY REELS

| | |
|---------------------|------|
| Reels, Welding..... | 1076 |
|---------------------|------|

HARPER TRUCKS INC.

| | |
|------------------|-----|
| Hand Trucks..... | 151 |
|------------------|-----|

HAWS

| | |
|---------------------------------|---------|
| Emergency Showers..... | 718-719 |
| Eyewash, Water Heater..... | 721 |
| Eyewash Stations | |
| Faucet Mounted..... | 720 |
| Pedestal Mounted..... | 717 |
| Self Contained..... | 722-723 |
| Sink Mounted..... | 720 |
| Wall Mounted..... | 716 |
| Water Preservatives..... | 722-723 |
| Thermostatic Mixing Valves..... | 721 |

HELLY HANSEN

| | |
|--------------------------|-----|
| High Visibility Clothing | |
| Overalls..... | 543 |
| Rain Jackets..... | 543 |
| Suits, Rain..... | 543 |

HERBERT WILLIAMS

| | |
|-----------------------------------|-----|
| Escape Ladders..... | 656 |
| Extinguishers, Fire..... | 652 |
| Hazardous Materials Cabinets..... | 665 |

HEXARMOR

| | |
|----------------------------|---------|
| Cut Resistant Gloves..... | 580-581 |
| Sleeves, SuperFabric®..... | 529 |

HIGHLAND

| | |
|-------------------|------|
| Message Pads..... | 1579 |
|-------------------|------|

HI-LITER

| | |
|------------------------|------|
| Hi-Liters..... | 1578 |
| Permanent Markers..... | 1578 |

HILL PUMPS

| | |
|------------------|-----|
| Pumps, Drum..... | 258 |
|------------------|-----|

HILMAN ROLLERS

| | |
|------------------------|---------|
| Machinery Rollers..... | 204-205 |
|------------------------|---------|

HILROY

| | |
|-------------------|------|
| Message Pads..... | 1579 |
|-------------------|------|

HLF DIVERSIFIED INC.

| | |
|-----------|-----|
| Salt..... | 364 |
|-----------|-----|

HOME SAFEGUARD INDUSTRIES, INC

| | |
|--------------------------|-----|
| Smoke Alarm Testers..... | 656 |
|--------------------------|-----|

HONEYWELL

| | |
|---|----------|
| Aprons..... | 531 |
| Ball Valve Lockouts..... | 783 |
| Circuit Breaker Lockouts..... | 782 |
| Disposable Dust Masks..... | 453 |
| Disposable Respirators..... | 452-453 |
| Electrical Plug Lockouts..... | 782 |
| Eyewash Stations | |
| Bottled..... | 724 |
| Self Contained..... | 722 |
| Solutions..... | 722-724 |
| Supplemental..... | 725 |
| Water Preservatives..... | 723, 725 |
| Half Mask Respirators..... | 458, 461 |
| High Visibility Clothing, Rain Suits..... | 543 |
| Hoods, Rain..... | 543 |
| Lockouts, Stations..... | 776 |
| PAPR Respirators..... | 480 |
| Respirators | |
| Cartridges..... | 461 |
| Filters..... | 461 |
| Fit Test Kits..... | 465 |
| SCBA Respirators..... | 469 |
| Sleeves | |
| Canvas..... | 528 |
| Kevlar®..... | 529 |
| PVC..... | 528 |
| Vinyl..... | 528 |
| Tags, Lockout..... | 789 |

HORIZON

| | |
|----------------------------------|------------------|
| Ergonomic Products, Seating..... | 1547-1549 |
| Footrests..... | 1549 |
| Keyboard Trays..... | 1558 |
| Keyboard Wrist Rests..... | 1558 |
| Office Seating..... | 1546, 1548, 1554 |
| Stacking Chairs..... | 1555 |
| Task Seating..... | 1546, 1552, 1554 |

HOWARD LEIGHT BY HONEYWELL

| | |
|---------------------|--------------|
| Ear Muffs | |
| Cap Mounted..... | 433-435 |
| Headband..... | 433-435, 549 |
| Neckband..... | 434 |
| Ear Plugs | |
| Corded..... | 423 |
| Dispensers..... | 427 |
| Disposable..... | 423-424, 427 |
| Reusable..... | 428 |
| Hearing Bands..... | 430 |
| Two-Way Radios..... | 435 |

HUBBELL

| | |
|-------------------------------|-----------|
| Cable Protectors, Office..... | 218, 1540 |
|-------------------------------|-----------|

HUDSON

| | |
|------------------------------|---------|
| Sprayers, Lawn & Garden..... | 372-373 |
|------------------------------|---------|

IDEAL

| | |
|-----------------------|------------|
| Spray Lubricants..... | 1012, 1543 |
| Wire Connectors..... | 1543 |

ILLINOIS

| | |
|----------------------|-------|
| Folding Gates..... | 82-83 |
| Security, Gates..... | 82-83 |

IMPACTO

| | |
|----------------------------|--------------|
| Anti-Vibration Gloves..... | 607 |
| Elbow Protectors..... | 643 |
| Foot Guards, Plastic..... | 637 |
| Forearm Protectors..... | 643 |
| Impact Gloves..... | 607, 644 |
| Insoles..... | 638 |
| Knee Pads | |
| Foam / Hard Shell..... | 640 |
| Hard Shell..... | 640 |
| Tennis Elbow Braces..... | 643 |
| Toe Guards..... | 637 |
| Wrist Supports..... | 643-644, 746 |

INCOM TOP TAPE & LABEL

| | |
|--|-----------|
| Aisle Marking Tape..... | 869-870 |
| Anti-Skid Tape..... | 872 |
| GHS | |
| Information Centres..... | 848 |
| Information Charts..... | 847 |
| Safety Labels..... | 844 |
| Glow in the Dark Tape..... | 870 |
| Handling Labels..... | 1448 |
| SDS | |
| Binders..... | 849 |
| Information Centre..... | 849 |
| Self-Adhesive Numbers..... | 800 |
| Tags, Lockout..... | 789 |
| Tape Dispensers, Aisle Marking Tape..... | 868 |
| TDG Labels..... | 855, 1448 |
| TDG Placards..... | 851-854 |
| WHMIS | |
| Information Charts..... | 847 |
| Posters..... | 847 |

INNOVA

| | |
|--------------------------|-----|
| Davits..... | 491 |
| Extinguishers, Fire..... | 652 |
| Manhole Shields..... | 491 |

INTEGRATED PLASTICS

| | |
|------------------------------|----------|
| Distribution Containers..... | 23, 1564 |
| Small Parts Cabinets..... | 34 |
| Stacking Bins..... | 5 |

INTERCON

| | |
|---------------------|------|
| Weld-On Hinges..... | 1088 |
|---------------------|------|

IPG

| | |
|-----------------------------------|------------|
| Aluminum Foil Tape..... | 1415 |
| Box Sealing Tape..... | 1410, 1413 |
| Double Sided Tape..... | 1416 |
| Duct Tape..... | 1415 |
| Filament Tape..... | 1412 |
| Gummed Tape..... | 1413 |
| Masking Tape..... | 1414 |
| Painter's..... | 1050 |
| Shrink Wrap..... | 1426 |
| Spray Adhesives..... | 1036 |
| Strapping, Tape..... | 1412 |
| Stretch Wrap | |
| Blown..... | 1424 |
| Cast..... | 1424, 1426 |
| Clear..... | 1424 |
| Machine..... | 1426 |
| Stretch Wrap Dispensers..... | 1426 |
| Tape Dispensers, Gummed Tape..... | 1413 |

IRON GUARD SAFETY

| | |
|-----------------------------------|-----|
| Bump Guard, Forklift..... | 186 |
| Bumpers, Dock..... | 213 |
| Checklist Kit, Forklift..... | 187 |
| Dock Lights, Stop & Go..... | 220 |
| Fenders, Dock..... | 212 |
| PPE Battery Kit, Forklift..... | 186 |
| Security, Gates..... | 866 |
| Speed Bumps, Traffic Control..... | 860 |
| Spot Lights..... | 187 |
| Trailer Jacks..... | 212 |
| Wheel Chocks..... | 210 |

IRP INDUSTRIAL RUBBER

| | |
|-------------------------------|------|
| Entrance Matting, Rubber..... | 901 |
| Hoses, Air..... | 1235 |

IRWIN

| | |
|--------------------------------------|-----------|
| Auger Bits..... | 1199 |
| Bar Clamps..... | 1285-1287 |
| Cable Cutters, Industrial Grade..... | 1352 |
| Chalk Lines..... | 1279 |
| Clamps, Pipe..... | 1285 |
| Drill Bits, Aircraft Extension..... | 972 |
| Forstner Bits..... | 1199 |
| Vis Grips..... | 1352 |
| Woodworking Chisels..... | 1367 |

ITW PRO BRANDS

| | |
|-------------------------------|----------|
| Stainless Steel Cleaners..... | 316 |
| Wipes..... | 316, 318 |

JACKSON SAFETY

| | |
|--------------------------------|------|
| ADF Filters..... | 1121 |
| Chemical Resistant Gloves..... | 589 |
| Filter Plate Lenses..... | 1122 |
| Goggles, Welding..... | 1120 |
| Ground Clamps, Welding..... | 1086 |

BRAND INDEX

Hand Shields, Welding..... 1123
 Helmets, Welding.....481, 1121-1123
 PAPR Respirators.....470, 481, 1122
 Respirators, Cartridges.....470

JACOBS

Chucks, Drill.....1268-1269
 Tool Holders, ER Collet Chucks.....1269

JEAMAR WINCHES

Hand Winches.....195

JET EQUIPMENT

Agricultural Jacks.....208
 Dollies, Mechanic's.....209

JOBOX

Tool Storage
 Chests.....1402-1403
 Jobsite Boxes.....1401-1407
 Van and Truck Equipment.....1407

JOHNSON

Bevels.....1280
 Carpenter Squares.....1280
 I-Beam Frame Levels.....1281
 Laser Levels.....1282-1283
 Rafter Squares.....1280
 T Squares, Drywall.....1280
 Torpedo Levels.....1281
 Try Squares.....1280

JOMAC CANADA

Chemical Resistant Gloves.....592
 Cut Resistant Gloves.....577, 579, 581
 Heat Resistant Gloves.....622-623
 Heat Resistant Mitts.....622
 Knit Gloves.....629
 Sleeves
 Cotton.....528
 Kevlar®.....529

JUSTRITE

Ashtrays.....236, 284, 657
 Bench Cans.....992
 Cabinet Carts.....660, 662
 Cabinets, Drum.....663, 665
 Cans, Safety.....668-669
 Covers, Drum.....236, 670
 Crimpers, Cap Seal.....250
 Dip Tanks.....992
 Dipping Baskets.....992
 Dispenser Bottles.....672
 Drip Cans.....670
 Drum Equipment
 Spill Pallets.....706-708
 Trays.....681
 Funnels, Drum.....251, 699
 Gas Cylinder, Cabinets.....1077
 Gauges, Drum.....251
 Hazardous Materials Cabinets.....660-667
 MSDS, Storage Boxes.....667
 Oily Waste Cans.....670-671
 Plunger Cans.....670
 Rinse Tanks.....992
 Vents, Drum.....251
 Wash Tanks.....992

KALAS

Cables, Welding.....1085

KANT-TWIST

Clamps, Pipe.....1285

KEE KLAMP

Kee Klamp® Pipe Fittings.....79-81
 Pneumatic Piping.....81

KEY-BAK

Chucks, Drill.....1269
 Key Chains.....1570-1571
 Label Holders.....1571

KILOTECH

Bench Scales.....1493-1495
 Counting Scales.....1491
 Crane Scales.....203, 1496
 Dial Scales.....1494
 Hanging Scales.....203, 1496
 Platform Scales.....1495
 Portable Scales.....1493
 Receiving Scales.....1494
 Test Weights.....1496
 Weighing Scales.....1491-1492

KIMBERLY-CLARK

Coated Gloves.....564
 Coveralls
 General Protection.....539
 Limited Use.....539
 Cut Resistant Gloves.....578
 Disposable Gloves.....596-597
 Lab Coats, General Protection.....539
 Wipes.....337-338
 Wipes Dispensers.....338

KIMBERLY-CLARK PROFESSIONAL

Blankets, Welding.....1118
 Helmets, Welding.....1123
 Screens, Welding.....1118-1119
 Umbrellas, Welding.....1118

KINEDYNE

Cargo Bars.....212, 1457
 Decking Beams.....212, 1457
 Jack Bars.....1457
 Load Binders.....192
 Logistic Straps.....246, 1456
 Logistic Tracks.....212, 1457
 Ratchet Straps.....1456
 Tie-Downs.....1456-1457

KING CANADA

Arbor Presses.....208
 Bench Grinders.....917, 1270
 Brushes, Parts Cleaning.....993
 Chop Saws.....914, 1174
 Compressors, Air.....1263
 Drill Presses
 Bench.....1266-1267
 Floor.....1266-1267
 Engine Tilters.....208
 Engine-Powered Pumps.....264
 Gearhead Machines, Drilling.....1267
 Guns
 Air.....1051
 Paint.....1051
 Hand Lamps.....1528
 Media Recyclers, Sandblasting.....1055
 Mitre Saws.....1176
 Parts Washers.....993
 Portable Blasters, Sandblasting.....1055

Shop Cranes.....208
 Work Stands.....225

KLEEN-FLO

Battery Acid Neutralizers.....1037

KLEIN TOOLS

Bolt Holder Pliers.....1349
 Cabinet Tip Screwdrivers.....1339
 Cable Cutters
 Industrial Grade.....1349, 1351
 Insulated.....1377
 Crimping Die Pliers.....1349, 1377
 Cross-Point Screwdrivers.....1339, 1378
 Diagonal Cutters.....1350, 1377
 Flat Tip Screwdrivers.....1339, 1378
 Locking Pliers.....1351
 Long Nose Pliers.....1351, 1377
 Needle Nose Pliers.....1351
 Nose Cutting Pliers.....1350
 Nut Drivers
 Cushion Grip.....1342
 Insulated.....1378
 Magnetic.....1342
 Sets.....1342
 Pump Pliers.....1377
 Rebar Tie Wire Cutters.....1350
 Screwdrivers, Sets.....1339
 Side Cutting Pliers.....1349, 1351, 1377
 Slip Joint Pliers.....1349
 Square Screwdrivers.....1339
 Technicians' Tools.....1378-1379
 Tongue & Groove Pliers.....1349
 Tool Storage
 Bags.....1393, 1464
 Belts.....1389
 Holders.....1387-1388
 Pouches.....1387-1388, 1390-1391
 Torque Screwdrivers.....1329
 Torx® Screwdrivers.....1339
 Wire Strippers.....1351
 Wire Stripping Pliers.....1377

KLETON

Bag Sealing Tape.....1436
 Bar Racks.....53
 Beam Trolleys.....190
 Bin Carts.....7-8
 Bin Racks.....8-9, 121
 Bin Shelves.....17, 60
 Bin Support Panels.....7
 Bins, Steel.....44
 Bollards.....54, 85
 Box Sealing Tape.....1410
 Box Trucks.....166, 172-173, 175
 Bumpers, Dock.....213
 Cabinets, Storage.....9-10, 99-100
 Carton Rack.....1434
 Carts, Welding.....1078
 Casters.....137, 152-154, 162, 164-165,
 176-177, 227-228, 245-246
 Corkboards.....1569
 Diaphragm Pumps.....258
 Dollies
 Aluminum.....177
 Drum.....244
 Wood.....176
 Drywall Carts.....159
 Extensions, Forklift.....187
 Faucets, Drum.....252
 Folding Chairs.....1554
 Folding Tables.....382, 1557
 Furniture Pads.....1454
 Gas Cylinder, Cabinets.....1077
 Guard Rails.....54, 84-85
 Hand Pumps.....256
 Hand Trucks.....144-146, 149-151, 1454, 1554

| | |
|-------------------------------|-----------------------------|
| Hoists, Manual..... | 190 |
| Horizontal Sheet Rack..... | 53 |
| Lift Tables..... | 178 |
| Lifters, Drum..... | 238, 243 |
| Locker Room Benches..... | 108, 382 |
| Lockers, Steel..... | 105 |
| Lumber Carts..... | 159-160 |
| Maintenance Platforms..... | 141 |
| Mesh Enclosures..... | 90 |
| Mesh Partitions..... | 51, 84-85, 88-89 |
| Order Picking Carts..... | 165 |
| Pallet Pullers..... | 186 |
| Pallet Trucks..... | 144, 182-183 |
| Panel Trucks..... | 160 |
| Perimeter Guards..... | 51, 84-85, 88 |
| Pipe Trucks..... | 160 |
| Platform Trucks | |
| Aluminum Deck..... | 155-156 |
| Dead Skids..... | 154 |
| Non-skid Vinyl Deck..... | 156 |
| Plastic Deck..... | 156 |
| Semi-Live Skids..... | 154 |
| Steel Deck..... | 152-153, 155, 160, 165 |
| Wood Deck..... | 153-154 |
| Pumps, Drum..... | 254-257 |
| Racks, Drum..... | 245 |
| Reel Dispensers..... | 167 |
| Rockers, Drum..... | 245 |
| Rolling Ladders..... | 135, 137-138 |
| Rotary Pumps..... | 257 |
| Seals, Steel..... | 1419 |
| Service Benches..... | 123-125 |
| Shelf Carts..... | 73, 76, 162-165, 167 |
| Shelving Units | |
| Chrome..... | 17, 70-72, 75 |
| Steel Wire..... | 73 |
| Shop Carts..... | 164 |
| Shop Desks..... | 126 |
| Small Parts Bins..... | 31 |
| Small Parts Cabinets..... | 30-32, 38 |
| Stackers..... | 180 |
| Stacking Bins..... | 4-5, 17 |
| Stacking Racks..... | 53-54 |
| Stepstands, Steel..... | 136 |
| Stepstools, Polyethylene..... | 136, 1549 |
| Stock Picking Carts..... | 165 |
| Stock Trucks..... | 166 |
| Strapping | |
| Dispensers..... | 1420 |
| Machines & Tools..... | 1419, 1422 |
| Steel..... | 1419 |
| Stretch Wrap Dispensers..... | 1424 |
| Strip Curtain Doors..... | 92 |
| Tape Dispensers | |
| Box Sealing Tape..... | 1411, 1429 |
| Filament Tape..... | 1412 |
| Tarpaulins..... | 379, 1453 |
| Tie-Downs..... | 683, 1455 |
| Tilt Trucks..... | 173 |
| Tipplers, Pail..... | 245 |
| Tool Storage, Carts..... | 123 |
| Trailer Jacks..... | 212 |
| Transfer Boxes..... | 19 |
| Trucks, Drum..... | 246 |
| Utility Carts..... | 76, 166, 168 |
| Valves, Drum..... | 252 |
| Vents, Drum..... | 251 |
| Vertical Sheet Rack..... | 53 |
| Wagons..... | 154 |
| Wheel Chocks..... | 210 |
| Wheels..... | 144, 246 |
| Whiteboards..... | 1569 |
| Work Platforms..... | 135-136 |
| Work Tables..... | 120 |
| Workbenches..... | 103, 112-117, 120-123, 1432 |
| Wrenches, Drum..... | 250 |

KNIPEX

| | |
|-------------------------|------|
| Technicians' Tools..... | 1379 |
|-------------------------|------|

KNUFFI

| | |
|----------------------|---------|
| Edge Protectors..... | 87, 216 |
|----------------------|---------|

KODIAK POWER EQUIPMENT

| | |
|---------------------------|---------|
| Engine-Powered Pumps..... | 264 |
| Pressure Washers..... | 374-375 |

KRYLON INDUSTRIAL

| | |
|--------------------|-----------|
| Marking Wands..... | 1038-1039 |
|--------------------|-----------|

Paint

| | |
|------------------------------------|----------------------|
| Acrylic..... | 1040, 1042-1044 |
| Alkyd..... | 1040-1041, 1043-1044 |
| Epoxy..... | 1042 |
| Floor..... | 1019 |
| High Heat..... | 1042-1043 |
| Latex..... | 1042 |
| Line Striping..... | 1039 |
| Marking..... | 1038 |
| Paint Supplies, Paint Remover..... | 1039 |
| Striping Machines..... | 1039 |

KUNY'S

| | |
|--------------------------|------------|
| Cell Phone, Holders..... | 1387, 1390 |
| Suspenders..... | 1389 |

Tool Storage

| | |
|--------------|----------------------|
| Aprons..... | 1391 |
| Bags..... | 1391-1393 |
| Belts..... | 1389 |
| Boxes..... | 1393 |
| Holders..... | 1387-1388 |
| Pouches..... | 1387-1388, 1390-1392 |

KYORITSU

| | |
|-----------------------------|------|
| Phase Rotation Testers..... | 1468 |
|-----------------------------|------|

L.B. WHITE

| | |
|-------------------------|-----------|
| Fan Forced Heaters..... | 1505 |
| Radiant Heaters..... | 1504-1505 |

LA-CO INDUSTRIES INC

| | |
|-------------------|------|
| Teflon® Tape..... | 1416 |
|-------------------|------|

LAKELAND

| | |
|-----------------------------|-----|
| Coveralls, Limited Use..... | 538 |
|-----------------------------|-----|

LAKESIDE MATERIAL HANDLING

| | |
|-----------------------|-----|
| Equipment Stands..... | 170 |
| Shelf Carts..... | 170 |
| Utility Carts..... | 170 |

Laurin

| | |
|------------------|-----|
| Tilt Trucks..... | 172 |
|------------------|-----|

LAVO

| | |
|-------------|-----|
| Bleach..... | 314 |
|-------------|-----|

LENCO

| | |
|--------------------------------|------|
| Cable Connectors, Welding..... | 1084 |
| Chipping Hammers, Welding..... | 1087 |

LEPAGE

| | |
|-------------------|------|
| Wood Fillers..... | 1022 |
|-------------------|------|

LEV-CO

| | |
|--------------------------|------|
| Air Filters..... | 1058 |
| Fume Extractor Fans..... | 1058 |

| | |
|----------------------------|-----------|
| Fume Extractors..... | 1058-1060 |
| Fume Filters, Welding..... | 1058-1059 |
| Mechanical Filters..... | 1059 |
| Portable Blowers..... | 1059 |
| Pressure Gauges, Dial..... | 1058 |

LEWIS BINS+

| | |
|------------------------------|--------|
| Distribution Containers..... | 18, 20 |
| Dollies, Stacking..... | 20 |
| ESD Products, Bins..... | 25 |

LIFE SAFE

| | |
|--------------------------|-----|
| Snow Clearing Posts..... | 871 |
|--------------------------|-----|

LIFT-RITE

| | |
|---------------------|-----|
| Pallet Lifters..... | 184 |
| Pallet Trucks..... | 186 |
| Stackers..... | 180 |

LINCOLN ELECTRIC

| | |
|-----------------------------------|-----------|
| Cold Wire Feeders, TIG Torch..... | 1091 |
| MIG Welders..... | 1092-1093 |
| Plasma Cutters..... | 1090 |
| Stick Electrodes..... | 1136 |
| TIG Welders..... | 1091 |
| Water Cooled Torches..... | 1091 |

LIND EQUIPMENT

| | |
|--------------------------------|-----------|
| Batteries, C Cell..... | 444, 1518 |
| Bonding & Grounding Wires..... | 252-253 |
| Cable Protectors, Dock..... | 217 |

Cord Reels

| | |
|----------------------|-----------------|
| Extension Cords..... | 1531-1532, 1537 |
| Fluorescent..... | 1532 |
| Incandescent..... | 1531-1532 |
| Quad Box..... | 1531 |
| Single Outlet..... | 1531 |
| Triple Outlet..... | 1532 |
| Work Lights..... | 1531 |

| | |
|----------------------|------|
| Cord Sets, GFCI..... | 1539 |
|----------------------|------|

Dock Lights

| | |
|-------------------|-----|
| Flexible..... | 218 |
| Halogen..... | 218 |
| Single Strut..... | 218 |

Extension Cords

| | |
|----------------------|------|
| Circuit Breaker..... | 1538 |
| Single Outlet..... | 1538 |

| | |
|------------------|-----------|
| Floodlights..... | 1526-1528 |
|------------------|-----------|

| | |
|------------------|------|
| Floor Lamps..... | 1527 |
|------------------|------|

| | |
|--------------------------------------|-----------|
| Fluorescent Lamps / Light Bulbs..... | 1525-1526 |
|--------------------------------------|-----------|

| | |
|----------------------------------|-----------|
| Halogen Lamps / Light Bulbs..... | 1527-1528 |
|----------------------------------|-----------|

| | |
|-----------------|-----------|
| Hand Lamps..... | 1525-1527 |
|-----------------|-----------|

| | |
|---------------------------|-----|
| Headlights, Hard Hat..... | 419 |
|---------------------------|-----|

| | |
|----------------------------|------|
| Outlet Adaptors, GFCI..... | 1540 |
|----------------------------|------|

| | |
|-------------------------|------|
| Outlet Boxes, GFCI..... | 1539 |
|-------------------------|------|

| | |
|------------------|------|
| Plugs, GFCI..... | 1540 |
|------------------|------|

| | |
|------------------|------|
| Spot Lights..... | 1518 |
|------------------|------|

| | |
|--------------------|------|
| String Lights..... | 1528 |
|--------------------|------|

| | |
|------------------------|------|
| Telescopic Lights..... | 1528 |
|------------------------|------|

LISTA

| | |
|------------------------------|---------|
| Cabinets, Storage..... | 94-96 |
| Open Wire Workstations..... | 118 |
| Shelving, Drawer Insert..... | 68-69 |
| Workbenches..... | 118-119 |

LITTLE GIANT PUMP COMPANY

| | |
|----------------------------|---------------|
| Coolant Tanks..... | 1150 |
| Machine Tool Pumps..... | 1150 |
| Multi-Purpose Ladders..... | 1150 |
| Submersible Pumps..... | 262-263, 1150 |
| Transfer Pumps..... | 263 |

BRAND INDEX

LLOYDS

Air Tool Oil.....1037, 1261
Graffiti Removers.....319, 1005

LOC-LINE

Loc-Line® Hosing.....1150-1153

LOCTITE

Accelerators, Adhesive.....1032
Adhesives
Acrylic.....1034
All Purpose.....1023
Aluminum Foil Tape.....1020
Anti-Seize.....1016
Anti-Slip Floor Coatings.....873, 1019
Bolt Removal Penetrants.....1013
Caulking Guns.....1035
Construction Adhesives.....1029
Contact Cleaners.....1007
Dielectric Greases.....1018
Epoxies
for Metal.....1020-1021
General Purpose.....1033-1034
Mixer Cups.....1021
Putty.....1020-1021
Syringe.....1021
Two Part.....1033
Epoxy Applicators.....1021, 1035
Fault Detectors, Welding.....1012, 1148
Flange Sealants.....1026
Floor Repair.....1019, 1021
Floor Sealers.....1019
Gaskets.....1025-1026
Glue Guns.....1035
Guns, Air.....1035
Instant Adhesives.....1031-1032
Paint, Rubber.....1012
Primers, Adhesive.....1032
Retaining Compounds.....1027
Rust Converters.....1014, 1146
Sealants, Silicone.....1025
Spray Lubricants.....1018
Structural Adhesives.....1032-1034
Synthetic Greases.....1018
Teflon® Tape.....1028
Thread Sealants.....1026
Threadlockers.....1020, 1027-1028
White Lithium Greases.....1018

LOUISVILLE LADDER

Double Stepladders.....130-131
Platform Ladders.....130
Scaffolding.....134
Stepstools, Fiberglass.....134

LPS

Anti-Seize.....1016
Anti-Spatter.....1147
Bearing Greases.....1017
Belt Dressing.....1012
Brake Cleaners.....1005
CFC Free Degreasers.....1002
Contact Cleaners.....1005-1006
Cutting Fluids, for all Metals.....1149
Degreasers
Heavy-Duty.....1002-1003
Multi-Purpose.....1002-1004
Dusters, Aerosol.....1006
Galvanizing Compounds.....1014, 1146
Hand Towels.....334, 1005
High Temperature Greases.....1017
Industrial Cleaners, Multi-Purpose.....1003
Machinery Oil.....1011
Multi-Purpose Greases.....1011, 1018

Penetrants

KB 88.....1013
Multi-Purpose.....1013
Permanent Markers.....1442
Rust Preventers.....1014, 1146
Solvent Free Degreasers.....1002-1003
Spray Lubricants.....1008-1011, 1013
White Lithium Greases.....1018

LUFKIN

Measuring Tape
Oil Gaging.....1279
Retractable Blade.....1276, 1278
Measuring Wheels.....1278
Plumb Bobs.....1279

LUXO

Magnifiers, Illuminated.....1524

LUXOR H. WILSON

Audio-Visual Carts.....1561
Computer Carts.....1561
Work Tables.....1556, 1561

LYON

Cabinets, Storage.....98-99
Lockers, Steel.....108
Shelving Units, Steel.....58

M & P TOOL PRODUCTS

Bins, Steel.....44

MAGIC

Stations, Lens Cleaning.....409
Tissues, Lens Cleaning.....409

MAGLINER

Dollies, Aluminum.....177
Hand Trucks.....148-149
Wheels.....148

MAGLITE

Flashlights
AA Cell.....1511
AAA Cell.....1509-1510
Belt Holsters.....1509-1511
CR123 Cell.....1511
D Cell.....1509-1510
Mini.....1509
Rechargeable.....1511
Traffic Wands.....1509

MAG-MATE

Bar Magnets.....1298
Ceramic Magnets.....1299
Cup Magnets.....1299
Ground Clamps, Welding.....1086
Grounds, Welding.....1086
Inspection Mirrors.....883
Magnetic Lifters.....198, 1298
Magnetic Retrievers.....1297-1298
Print Holders.....1298
Rare Earth Magnets.....1299
Squares, Welding.....1086
Strip Magnets.....1298
Sweeper Magnets.....286
Sweepers.....286

MAGNAFLUX

Fault Detectors, Welding.....1020, 1144
Non-Chlorinated Cleaners.....1020, 1144
Non-Chlorinated Developers.....1020, 1144
Penetrants, Water Based.....1144

MAKITA

Angle Drills, Electric.....1184
Angle Grinders, Electric.....916, 1163, 1168-1169, 1171
Battery Chargers, Cordless Drill.....1167
Chop Saws.....1174
Circular Saws, Heavy-Duty.....1177
Combo Kits.....1164-1166
Compressors, Air.....1262
Cordless Power Tool Batteries 1156-1157, 1160-1161, 1164, 1167
Cordless Screwdrivers.....1161, 1187
D Handle Drills.....1183
Demolition Hammers.....1187
Die Grinders, Electric.....1172
Drills, Drill / Drivers - Cordless.....1156-1158
Flashlights
12 V.....1162
18 V.....1162
Rechargeable.....1162
Hand Powered Drills.....1182
Heat Guns.....1190
Impact Wrenches
Cordless.....1160
Electric.....1181
Jig Saws
Heavy-Duty.....1178
Orbital.....1178
Mitre Saws.....1175
Nibblers.....1173
Palm Sanders.....1180
Power Scrapers.....1186
Reciprocating Saws, Electric.....1179
Shears, Power.....1173

MALLORY

Extension Poles.....297, 299
Round Nose Pliers.....364
Snow Brushes.....364
Snow Shovels.....364
Squeegees.....296, 299
Window Washers.....299

MAPA PROFESSIONAL

Chemical Resistant Gloves.....585, 589-590

MARIGOLD INDUSTRIAL

Chemical Resistant Gloves.....585, 589-590, 588-589
Gloves, High Voltage.....558

MARINO

Bags, Laundry.....303
Boot Brushes.....291
Broom & Mop Racks.....286
Buckets.....306
Carts, Laundry.....303
Floor Scrapers.....292
Garbage Cans.....272
Hand Scrubbers.....302, 320
Litter Pickers.....282, 383
Litter Scoops.....282, 383
Magnetic Brooms.....290
Nippers, End Cut.....282, 383
Plungers, Toilet.....349
Trigger Sprayers.....302, 320

MARKAL

Grease Pencils.....1142, 1445

| | |
|--------------------------|-----------------|
| Liquid Tip Markers..... | 1445 |
| Lumber Crayons..... | 1142, 1444 |
| Metal Markers..... | 1444 |
| Paint Markers..... | 1142, 1443-1444 |
| Paint Sticks..... | 1142, 1443-1444 |
| Permanent Markers..... | 1445 |
| Teflon® Tape..... | 1027 |
| Temperature Crayons..... | 1142, 1445 |
| Whiteboard Markers..... | 1569 |

MARLEY INDUSTRIAL PRODUCTS

| | |
|-----------------------|------|
| Portable Blowers..... | 1060 |
| Portable Heaters..... | 1504 |
| Radiant Heaters..... | 1504 |
| Wall Heaters..... | 1504 |

MARSH

| | |
|-----------------------|-----|
| Fountain Brushes..... | 799 |
| Fountain Rollers..... | 799 |
| Hand Rollers..... | 799 |
| Stencil Inks..... | 799 |

MASTER LOCK

| | |
|---------------------------------|-------------------|
| Ball Valve Lockouts..... | 780, 782-784 |
| Bungee Cords..... | 1455, 1457 |
| Butterfly Valve Lockouts..... | 783 |
| Cable Lockouts..... | 779 |
| Circuit Breaker Lockouts..... | 781 |
| Dielectric Hasp Lockouts..... | 780 |
| Electrical Plug Lockouts..... | 781 |
| Electrical Switch Lockouts..... | 781 |
| Gate Valve Lockouts..... | 784 |
| Hasp Lockouts..... | 764, 768-769, 780 |
| Key Cabinets..... | 1570 |
| Key Tags..... | 1570 |
| Lock Labels..... | 770 |
| Lockouts | |
| Confined Space..... | 784 |
| Kits..... | 772, 778-779 |
| Stations..... | 773-775 |
| Padlock Caddy..... | 773 |
| Padlocks..... | 110, 764-772 |
| Pneumatic Fitting Lockouts..... | 1250 |
| Safes..... | 1577 |
| Tie-Downs..... | 1456 |

MAT TECH

| | |
|---------------------------|--------------|
| Anti-Fatigue Matting..... | 908-909 |
| Entrance Matting | |
| Carpet..... | 886-887 |
| Eco..... | 886 |
| Needle Rib..... | 885 |
| Pile..... | 885-887 |
| Polypropylene..... | 885 |
| Rubber..... | 886-887, 909 |
| Wiper..... | 874, 885-887 |

MATRIX INDUSTRIAL PRODUCTS

| | |
|------------------------------|------------|
| Ceiling Mounted Heaters..... | 1504 |
| Drum Fans..... | 1502 |
| Fan Forced Heaters..... | 1503 |
| Floor Fans..... | 1499 |
| Office Fans..... | 1499 |
| Pedestal Fans..... | 1497, 1499 |
| Radiant Heaters..... | 1503 |
| Radiator Heaters..... | 1503 |
| Wall Clocks..... | 1575 |
| Wall Mounted Fans..... | 1497, 1499 |

MAYFIELD

| | |
|----------------------|-----|
| Funnels, Steel..... | 993 |
| Liquid Measures..... | 993 |

MECHANIX WEAR

| | |
|---------------------------------|-----------|
| Anti-Vibration Gloves..... | 606 |
| Ergonomic Products, Gloves..... | 602, 605 |
| Impact Gloves..... | 606 |
| Leather Gloves..... | 621, 1131 |

MEGAPRO

| | |
|-----------------------------|------|
| Multi-Tip Screwdrivers..... | 1341 |
|-----------------------------|------|

MEGGER

| | |
|-------------------------|------|
| Insulation Testers..... | 1467 |
|-------------------------|------|

MELNOR

| | |
|-------------------------------|-----|
| Garden Hoses..... | 378 |
| Guns, Garden Hose..... | 376 |
| Oscillators, Garden Hose..... | 376 |
| Repair Kits, Hose..... | 377 |
| Sprinklers, Garden Hose..... | 376 |
| Timers, Mechanical..... | 378 |

MERIT

| | |
|------------------------|----------|
| Backing Pads..... | 922 |
| Cartridge Rolls..... | 929 |
| Disc Holder Pads..... | 922, 924 |
| Flap Wheels..... | 920 |
| Power-Lock Discs..... | 924 |
| Resin Fibre Discs..... | 922 |
| Spiral Bands..... | 929 |

METABO

| | |
|--------------------|------|
| Hammer Drills..... | 1184 |
| Heat Guns..... | 1190 |

METALTECH

| | |
|------------------------|---------|
| Extension Ladders..... | 135 |
| Scaffolding..... | 141-143 |

METALWARE

| | |
|----------------|-------|
| Shelving Units | |
| Steel..... | 62-67 |
| Widespan..... | 57 |

METRO

| | |
|----------------------|-----|
| Garbage Cans..... | 169 |
| Security, Carts..... | 77 |
| Shelf Carts..... | 77 |
| Shelving Units | |
| Chrome..... | 74 |
| Plastic..... | 75 |
| Steel Wire..... | 75 |
| Utility Carts..... | 169 |
| Workbenches..... | 120 |

MICRELL

| | |
|----------------------------|-----|
| Hand Cleaners, Lotion..... | 324 |
| Soap Dispensers..... | 324 |

MIDWEST

| | |
|--------------------|------|
| Table Caddies..... | 1557 |
|--------------------|------|

MILLER BY HONEYWELL

| | |
|------------------------------|----------|
| Anchorage Connectors..... | 519 |
| Arc Rated Harness..... | 500, 560 |
| Arc Rated Lanyards..... | 510, 560 |
| Beam Clamps..... | 519 |
| Beam Trolleys..... | 519 |
| Carabiners..... | 520 |
| Cross-Arm Strap Anchors..... | 519, 560 |

| | |
|---------------------------------|---------|
| D-Bolt Anchors..... | 519 |
| Fall Protection, Harnesses..... | 497-499 |
| Fall Protection Kits..... | 505 |
| Rescue Systems..... | 492 |
| Rope Grabs..... | 520 |
| Self-Retracting Life Lines..... | 514-515 |
| Shock Absorbing Lanyards..... | 508-510 |
| Tie-Back Lanyards..... | 509-510 |
| Vertical Life Lines..... | 520 |
| Welding Harnesses..... | 500 |
| Welding Lanyards..... | 510 |

MILLSIDE

| | |
|-------------|-----|
| Wagons..... | 370 |
|-------------|-----|

MILWAUKEE

| | |
|---|----------------------|
| Angle Drills, Electric..... | 1184 |
| Angle Grinders, Electric..... | 916, 1163, 1168-1170 |
| Bandsaws | |
| Metal Cutting..... | 1178 |
| Wood Cutting..... | 1178 |
| Battery Chargers, Cordless Drill..... | 1167 |
| Chop Saws..... | 914, 1174 |
| Circular Saws, Heavy-Duty..... | 1162, 1177 |
| Close Quarter Drills..... | 1184 |
| Combo Kits..... | 1164-1166 |
| Cordless Power Tool Batteries..... | 1156-1164, 1167 |
| Core Bits..... | 1194 |
| Coring Motors..... | 1189 |
| D Handle Drills..... | 1183-1184 |
| Die Grinders, Electric..... | 1172 |
| Drill Bits | |
| Hex Shank..... | 1198 |
| Through-Hole..... | 1199 |
| Two-Piece..... | 1193 |
| Drill Presses, Electromagnetic..... | 1188-1189 |
| Drills, Drill / Drivers - Cordless..... | 1156, 1161, 1164 |
| Flashlights | |
| 12 V..... | 1162 |
| Rechargeable..... | 1162 |
| Floodlights..... | 1162 |
| Grease Guns..... | 1161 |
| Hammer Drill / Drivers..... | 1157-1159 |
| Hammer Drills..... | 1158-1159, 1185-1187 |
| Hand Chisels..... | 1194 |
| Hand Powered Drills..... | 1182-1183, 1186 |
| Heat Guns..... | 1190 |
| Hole Saw Arbors..... | 1193, 1198 |
| Hole Saws..... | 1197-1198 |
| Impact Wrenches | |
| Cordless..... | 1159-1160 |
| Electric..... | 1181 |
| Infrared Thermometers..... | 1470 |
| Jig Saws, Orbital..... | 1178 |
| Knockout Tools..... | 1162 |
| Mitre Saws..... | 1176 |
| Nibblers..... | 1173 |
| Palm Sanders..... | 1180 |
| Points, Cutting..... | 1194 |
| Reciprocating Saw Blades..... | 1201 |
| Reciprocating Saws | |
| Cordless..... | 1163 |
| Electric..... | 1179 |
| Rotary Cutters..... | 1163 |
| Rotary Hammers..... | 1159, 1186-1187 |
| Scaling Chisels..... | 1194 |
| Screw Guns..... | 1187 |
| Shears, Power..... | 1173 |

MMF INDUSTRIES

| | |
|-------------------|------|
| Key Cabinets..... | 1570 |
| Key Racks..... | 1570 |
| Key Tags..... | 1570 |

BRAND INDEX

MOBILE INDUSTRIES

| | |
|--------------------|---------|
| Pallet Trucks..... | 184-186 |
| Stackers..... | 180 |

MOLDEX

| | |
|-----------------------------|----------|
| Disposable Respirators..... | 450-451 |
| Ear Muffs | |
| Headband..... | 435 |
| Hygiene Kits..... | 435 |
| Ear Plugs | |
| Dispensers..... | 427 |
| Disposable..... | 426 |
| Reusable..... | 426, 429 |
| Full Face Respirators..... | 462 |
| Half Mask Respirators..... | 462 |
| Hearing Bands..... | 431 |
| Respirators | |
| Cartridges..... | 462 |
| Welding..... | 450 |

MONOFLO INTERNATIONAL, INC.

| | |
|-----------------------|----|
| Pallets, Plastic..... | 47 |
|-----------------------|----|

MORSE

| | |
|---------------------|---------|
| Dollies, Drum..... | 244 |
| Funnels, Drum..... | 241 |
| Lifters, Drum..... | 239-243 |
| Rotators, Drum..... | 248 |
| Spotters, Drum..... | 247 |
| Tilters, Drum..... | 239-240 |
| Trucks, Drum..... | 247 |
| Tumblers, Pail..... | 248 |
| Upenders, Drum..... | 250 |
| Wrenches, Drum..... | 250 |

MOTOROLA

| | |
|---------------------|---------|
| Two-Way Radios..... | 441-442 |
|---------------------|---------|

MR. CHAIN

| | |
|---------------------------|-----|
| Chain, Crowd Control..... | 880 |
| Posts, Crowd Control..... | 880 |

MR. CLEAN

| | |
|---------------------|-----|
| Floor Cleaners..... | 317 |
|---------------------|-----|

MRB

| | |
|---------------------------|------|
| Shrink Wrap Machines..... | 1426 |
|---------------------------|------|

MSA

| | |
|---------------------------------|---------|
| Docking Stations..... | 485-486 |
| Ear Muffs, Cap Mounted..... | 439 |
| Faceshields..... | 413 |
| Full Face Respirators..... | 463 |
| Gas Detectors | |
| Calibration Gas..... | 485-486 |
| Sensor..... | 485-486 |
| Half Mask Respirators..... | 463-464 |
| Hard Hats..... | 417-418 |
| Multi-Gas Detectors..... | 485-486 |
| Regulator, Calibration Gas..... | 485-486 |
| Respirators | |
| Cartridges..... | 463-464 |
| Filters..... | 464 |
| Single-Gas Detectors..... | 485 |

MUR-VAN

| | |
|---------------------|-----------------|
| Casters..... | 1550 |
| Office Seating..... | 1554 |
| Swivel Stools..... | 1554 |
| Task Seating..... | 1550-1552, 1554 |

MUSCLE MATE

| | |
|---------------------------|----------|
| Bins, Steel..... | 45 |
| Floor Cranes..... | 200, 202 |
| Gantry Cranes..... | 200 |
| Jib Booms..... | 201 |
| Jib Cranes..... | 201 |
| Pallet Lifters..... | 201 |
| Shop Cranes..... | 202 |
| Truck Mounted Cranes..... | 202 |

NALGENE

| | |
|-----------------------|----|
| Bottles, Storage..... | 28 |
| Jars, Storage..... | 28 |

NAS

| | |
|----------------------------|----|
| Shelving Units, Steel..... | 57 |
| Tire Racks..... | 78 |

NASHVILLE WIRE

| | |
|-----------------------------|----|
| Collapsible Containers..... | 44 |
|-----------------------------|----|

NEOS

| | |
|----------------|-----|
| Overshoes..... | 634 |
|----------------|-----|

NEPTUNE

| | |
|-----------|-----|
| Mixers | |
| Drum..... | 249 |
| Pail..... | 249 |

NEXAL

| | |
|-------------------------|------|
| MIG Wire, Aluminum..... | 1138 |
|-------------------------|------|

NICHOLSON

| | |
|---------------------------|------------|
| File Cleaners..... | 1307 |
| File Handles..... | 1307 |
| Files, Sets..... | 1306-1307 |
| Flat Files..... | 1302-1305 |
| Hacksaws | |
| Blades..... | 1300 |
| Frames..... | 1301 |
| Half Round Files..... | 1303 |
| Half Round Rasps..... | 1305 |
| Round Files..... | 1302, 1304 |
| Round Rasps..... | 1305 |
| Square Files..... | 1304 |
| Thread Repair, Files..... | 1307 |
| Triangular Files..... | 1304-1305 |

NILFISK

| | |
|-------------------------|----------|
| Vacuums, Wet / Dry..... | 361, 688 |
|-------------------------|----------|

NOGA

| | |
|---------------------------|------|
| Deburring Hand Tools..... | 1308 |
|---------------------------|------|

NORTECH

| | |
|-------------------------|-----|
| Vacuums, Wet / Dry..... | 361 |
|-------------------------|-----|

NORTH BY HONEYWELL

| | |
|-----------------------------------|--------------|
| Anchorage Connectors..... | 519 |
| Bump Caps..... | 417 |
| Carabiners..... | 520 |
| Chemical Resistant Gloves..... | 584, 592 |
| Davits..... | 491 |
| Disposable Respirators..... | 452 |
| Emergency Escape Respirators..... | 459 |
| Faceshields..... | 410-411 |
| Fall Protection, Harnesses..... | 501-502, 519 |
| Fall Protection Kits..... | 505-506 |

| | |
|---------------------------------|---------------|
| Full Face Respirators..... | 458-459, 469 |
| Glasses, Safety..... | 397-398 |
| Half Mask Respirators..... | 458, 469 |
| Hard Hats..... | 416-417 |
| PAPR Respirators..... | 480 |
| Rescue Hoist..... | 492 |
| Rescue Systems..... | 492 |
| Respirators | |
| Cartridges..... | 460, 480 |
| Filters..... | 452, 459, 480 |
| Rope Grabs..... | 520 |
| Sandblasting Gloves..... | 591 |
| Self-Retracting Lanyards..... | 515 |
| Self-Retracting Life Lines..... | 515 |
| Shock Absorbing Lanyards..... | 510 |
| Vertical Life Lines..... | 520 |

NORTON

| | |
|---------------------------------|-----------|
| Backing Pads..... | 927 |
| Benchstand Belts..... | 929 |
| Circular Saw Blades..... | 914 |
| Crimped Filament Wheels..... | 912-913 |
| Cut-Off Wheels..... | 912-915 |
| Flap Discs..... | 918-919 |
| Grinding Wheels | |
| Bench Mounted..... | 917, 1271 |
| Type 27..... | 915-916 |
| Zirconium..... | 913-915 |
| Grip-On Discs..... | 926 |
| Portable Belts..... | 928 |
| Portable File Belts..... | 928 |
| Power-Lock Discs..... | 924 |
| Sandpaper..... | 931 |
| Stick-On Discs..... | 926-927 |
| Surface Conditioning Discs..... | 934 |
| Surface Conditioning Pads..... | 933 |
| Surface Conditioning Rolls..... | 930, 934 |

NUCO

| | |
|-----------------------------|------|
| Caulking Guns..... | 1023 |
| Construction Adhesives..... | 1029 |
| Epoxies | |
| General Purpose..... | 1023 |
| Putty..... | 1023 |
| Foam Sealants..... | 1023 |

OASIS

| | |
|----------------------|-----------|
| Water Filters..... | 1585 |
| Water Fountains..... | 1585-1586 |

OATEY

| | |
|----------------------|------|
| Pipe Cements..... | 1022 |
| Plumbers' Putty..... | 1022 |
| Teflon® Tape..... | 1416 |

OBERDORFER

| | |
|------------------|-----|
| Pumps, Drum..... | 258 |
|------------------|-----|

OETIKER INC

| | |
|--------------------------------|------|
| Hose Repair Kits, Welding..... | 1075 |
|--------------------------------|------|

OHAUS

| | |
|----------------------|-----------------|
| Bench Scales..... | 1491-1492, 1495 |
| Floor Scales..... | 1496 |
| Platform Scales..... | 1495 |
| Portable Scales..... | 1492 |

OIL-DRI

| | |
|-----------------|-----|
| Absorbents..... | 684 |
|-----------------|-----|

OLD DUTCH

Scouring Powder.....316

OLFA

Blades, Packaging Knife.....1425, 1430, 1434, 1438-1439, 1442
Cases, Blade Disposal.....1438
Knives, Packaging.....1425, 1430, 1434, 1438-1439, 1442
Scissors, Industrial.....1442
Utility Knives.....1442

OLYMPIC

Wire Measurers.....1484

OMEGA COMPRESSORS

Compressors, Air.....1263

OMNIGLOW

Lightsticks.....860

ONGUARD INDUSTRIES

Boot Covers.....632
Chemical Resistant Boots.....631
Chest Waders.....633
Hip Waders.....633
Knee Boots.....631-632
Overboots.....633
Overshoes.....633
Work Boots.....632

OPTREL

ADF Filters.....1124-1125
Beanies, Welding.....1125
Chest Protectors, Welding.....1125
Helmets, Welding.....1124-1125
Neck Protectors, Welding.....1125

ORBIS

Collapsible Containers.....45
Distribution Containers.....22-23
ESD Products, Bins.....25
Pallets, Plastic.....46-48, 1423

OSBORN

Brushes
Acid.....1141, 1145
Parts Cleaning.....993
Compressors, Air.....1264-1265
Paint Supplies, Brushes.....1046
Scrub Brushes.....291, 946
Wheel Brushes.....941, 1271

PACER

Pumps, Drum.....258

PANAVISE

Tilting Vises.....1296

PAPER MATE

Pencils.....1578
Pens, Office.....1578

PARCO

Bicycle Racks.....379

PARTLOW

Temperature Recorders.....1476

PELICAN

Cell Phone
Accessories.....443
Holders.....443
Equipment Cases.....1465
Flashlights
AA Cell.....1514, 1516, 1518
AAA Cell.....1514
C Cell.....1516
Coin.....1514
Mini.....1514
Waterproof.....1518
Floodlights.....1530
Task Lights.....1530

PELTOR

Ear Muffs
Cap Mounted.....436-438
Headband.....436-438
Neckband.....436-437
Two-Way Radios.....438-439

PERFIX INC.

Filing Cabinets, Lateral.....1563
Lockers, Steel.....107

PESOLA

Hanging Scales.....1493

PHOENIX INTERNATIONAL

Electrode Ovens.....1089
Rod / Electrode Containers.....1089

PICQUIC

Hex Square Drive Bits.....1340
Multi-Tip Screwdrivers.....1340

PLASTIC RECYCLING

Bollards.....865
Park Benches.....380
Parking Curbs, Traffic Control.....861
Picnic Tables.....380

PLASTICOR

Anti-Fatigue Matting.....906

PLEDGE

Furniture Polish.....319

PLUMB

Ball Pein Hammers
Fiberglass Handle.....1365
Wood Handle.....1365
Blacksmiths' Hammers.....1366
Brick Hammers.....1364
Claw and Ripping Hammers.....1364
Claw Hammers.....1364
Curved Claw Hammers.....1364
Double Faced Hammers.....1366
Scaling Hammers.....1364

POLARPRO

Forks, Cafeteria.....1583
Knives, Cafeteria.....1583
Spoons, Cafeteria.....1583

POLYAIR

Bubble Mailers.....1435

Bubble Pouches.....1435
Bubble Wrap.....1427
Foam, Packaging.....1427

PORTER CABLE

Belt Sanders, Electric.....1180

POST-IT

Message Pads.....1579

PR88

Hand Creams.....333

PRECISION BRAND

Feeler Gauge Stock.....1274
Shims.....1273-1274
Stock.....1274

PRECISION TWIST DRILL

Combined Drills & Countersinks.....961
Drill Bits
Jobber.....949-953
Silver & Deming.....954
Stub.....953-954
Taper Shank.....955

PRIME

Cord Reels, Extension Cords.....1537
Cord Sets, GFCI.....1539
Extension Cords
Double Outlet.....1541
Single Outlet.....1536, 1538, 1541
Triple Outlet.....1535-1536
Power Bars.....1541
Power Strips, GFCI.....1540-1541

PROBUILT PROFESSIONAL

Flashing Lights.....863
Fluorescent Lamps / Light Bulbs.....1529-1530
Task Lights.....1529-1530

PRODUITS RE-PLAST

Park Benches.....380
Picnic Tables.....380

PROTECTA

Anchorage Connectors.....516
D-Bolt Anchors.....516
Fall Protection, Harnesses.....496
Fall Protection Kits.....507
Rescue Systems.....490
Rope Grabs.....517
Self-Retracting Lanyards.....513
Self-Retracting Life Lines.....513
Shock Absorbing Lanyards.....508
Welding Harnesses.....496

PROTECTIVE LINING CORP

Inserts, Pail.....235
Liners, Drum.....235

PS DOORS

Security, Gates.....84

BRAND INDEX

PTC INSTRUMENTS

| | |
|---------------------|------|
| Hardness Testers | |
| Non-Metals..... | 1479 |
| Steel & Alloys..... | 1479 |

PURDY

| | |
|------------------------------|------|
| Paint Supplies, Brushes..... | 1048 |
|------------------------------|------|

PURELL

| | |
|--------------------------------|--------------|
| Hand Sanitizer Dispensers..... | 323-324 |
| Hand Sanitizers..... | 323-324, 760 |

PYROCHEM

| | |
|--------------------------|-----|
| Extinguishers, Fire..... | 652 |
|--------------------------|-----|

QRP

| | |
|------------------------|----------|
| Disposable Gloves..... | 596, 598 |
| Fingercots..... | 600 |

QUALITY RAILINGS

| | |
|-------------------|-----|
| Dock Equipment | |
| Dockboards..... | 215 |
| Dockplates..... | 215 |
| Twin Ramps..... | 214 |
| Walkkramps..... | 214 |
| Wheel Risers..... | 215 |

QUANTUM STORAGE SYSTEM

| | |
|------------------------------|-------------------|
| Bin Racks..... | 39 |
| Bin Shelves..... | 16, 21, 59 |
| Cabinets, Storage..... | 35 |
| Distribution Containers..... | 19 |
| Gaylord Liners..... | 4 |
| Mobile Bins..... | 6 |
| Nesting Bins..... | 19, 26 |
| Shelf Bins..... | 13, 15, 25 |
| Small Parts Bins..... | 25, 39 |
| Stacking Bins..... | 6, 13, 16, 21, 26 |
| Storage, Stacking Bins..... | 4 |

QUARTET

| | |
|---------------------------------|------|
| Audio-Visual Carts..... | 1560 |
| Whiteboard Dry Erase Wipes..... | 1569 |

RABCO

| | |
|-------------------|-----|
| Boot Brushes..... | 889 |
|-------------------|-----|

RALSTON MIRRORS

| | |
|-------------------------|-----|
| Inspection Mirrors..... | 883 |
|-------------------------|-----|

RAYTEK

| | |
|----------------------------|------|
| Infrared Thermometers..... | 1469 |
|----------------------------|------|

RED KAP

| | |
|----------------------|-----|
| Coveralls, Work..... | 550 |
| Lab Coats..... | 550 |
| Pants, Work..... | 550 |
| Shirts, Work..... | 550 |
| Shop Coats..... | 550 |

REED

| | |
|-----------------------------|------------|
| Air Quality Monitors..... | 487, 1474 |
| Alligator Clips..... | 1460, 1463 |
| Batteries, 6 Volt..... | 1470 |
| Bi-Metal Thermometers..... | 1473 |
| Carbon Monoxide Meters..... | 487 |
| Circuit Testers..... | 1461 |

| | |
|---------------------------------|------------------------|
| Clamp Meters | |
| AC / DC..... | 1466 |
| Current Clamps..... | 1461, 1466, 1468, 1540 |
| True RMS..... | 1460, 1466 |
| Combustible Gas Detectors..... | 487 |
| Conductivity Meters..... | 1490 |
| Digital Thermometers..... | 1473 |
| Equipment Cases..... | 1461, 1464, 1471 |
| Force Gauges..... | 1484 |
| Hardness Testers | |
| Non-Metals..... | 1479 |
| Steel & Alloys..... | 1479 |
| Heat Stress Meter..... | 645, 1475 |
| Humidity Meters, Infrared..... | 1475 |
| Hygrometers, Thermo..... | 1474, 1476 |
| Infrared Thermometers..... | 1469-1470 |
| Inspection Cameras..... | 1376, 1485 |
| Borescope..... | 1485 |
| Insulation Testers..... | 1467 |
| Integral Probe Anemometers..... | 1486-1487 |
| Laser Distance Kits..... | 1482 |
| Laser Levels..... | 1461 |
| LCR Meters..... | 1468 |
| Light Meters, Digital..... | 1481 |
| Manometers..... | 1487-1488 |
| Moisture Meters..... | 1477 |
| Motor Rotation Testers..... | 1468 |
| Multimeters | |
| AC/DC..... | 1460, 1462 |
| Electrical..... | 1460 |
| True RMS..... | 1460 |
| ORP Meters..... | 1490 |
| pH Meters..... | 1490 |
| Porosity Detectors..... | 1478 |
| Pressure Gauges | |
| Dry..... | 1232, 1489 |
| Liquid Filled..... | 1489 |
| Psychrometers..... | 1475 |
| Refractometers..... | 1490 |
| Sound Level Meters | |
| Digital..... | 440, 1480 |
| Integral Probe..... | 440, 1480-1481 |
| Stem Thermometers..... | 1473 |
| Stopwatches..... | 645, 1475, 1483 |
| Stroboscopes..... | 1483 |
| Surface Mount Thermometers..... | 1473 |
| Tachometers..... | 1482 |
| Tally Counters..... | 1483 |
| Temperature Probes..... | 1471, 1475 |
| Test Leads..... | 1463 |
| Test Probes..... | 1463 |
| Testers, Multi-Function..... | 1462 |
| Thermal Cameras..... | 1470 |
| Thermocouple Probes..... | 1471 |
| Thermocouple Thermometers..... | 1429, 1471, 1474-1475 |
| Thermometer / Hygrometers..... | 645, 1474-1476 |
| Thickness Gauges..... | 1478-1479 |
| Vane Anemometers..... | 1486 |
| Vibration Meters..... | 1484 |
| Voltage Testers..... | 1462 |

REELCRAFT

| | |
|----------------------|-----------------|
| Cord Reels | |
| Fluorescent..... | 1532 |
| Single Outlet..... | 1532 |
| Hose Reel Carts..... | 1237 |
| Hose Reels..... | 1235-1237, 1532 |

RELTON

| | |
|-------------------------|-----------|
| Cutting Fluids | |
| for all Metals..... | 1148 |
| for Aluminum..... | 1148 |
| Drill Bits | |
| Masonry..... | 1196 |
| Splines-Shank..... | 1196 |
| Rotary Hammer Bits..... | 1195-1196 |

REMCO PRODUCTS

| | |
|------------------------------|-----|
| Scoops, Spill Control..... | 687 |
| Scrapers, Spill Control..... | 687 |
| Shovels, Spill Control..... | 686 |
| Squeegees..... | 687 |

REMCON PLASTICS INCORPORATED

| | |
|-----------------------|-----|
| Lockers, Plastic..... | 110 |
|-----------------------|-----|

RICHARD

| | |
|----------------------------------|-----------|
| Blades, Packaging Knife..... | 1440-1441 |
| Flooring Knives..... | 1441 |
| Hawks..... | 1053 |
| Knives | |
| Drywall..... | 1053 |
| Packaging..... | 1440 |
| Linoleum Knives..... | 1441 |
| Mixers, Paint..... | 1046 |
| Paint Supplies, Accessories..... | 1050 |
| Putty Knives..... | 1052 |
| Razor Blades..... | 1052 |
| Roofing Knives..... | 1441 |
| Rubber Cutting Knives..... | 1441 |
| Sanders, Hand..... | 1053 |
| Sanding Blocks..... | 1053 |
| Saws, Drywall..... | 1053 |
| Scrapers, Drywall..... | 1052 |
| Spreaders, Adhesive..... | 1053 |
| Trowels, Drywall..... | 1053 |
| Utility Knives..... | 1440-1441 |

RIDGID

| | |
|---------------------------------|------------|
| Chain Wrenches..... | 1372 |
| Compound Leverage Wrenches..... | 1372 |
| Drain Augers..... | 1375 |
| End Wrenches..... | 1373 |
| Flaring Tools..... | 1374 |
| Hex Wrenches..... | 1372 |
| Inspection Cameras..... | 1376, 1485 |
| Offset Wrenches..... | 1373 |
| Spud Wrenches..... | 1372 |
| Straight Wrenches..... | 1373 |
| Strap Wrenches..... | 1372 |
| Toilet Augers..... | 1375 |
| Tubing Cutters..... | 1374 |
| Wrenches, Pipe..... | 1373 |

RIEKE

| | |
|---------------------|-----|
| Wrenches, Drum..... | 250 |
|---------------------|-----|

RMP

| | |
|---|--------------|
| Buckets..... | 307 |
| Carts, Janitorial..... | 309 |
| Degreasers | |
| Heavy-Duty..... | 312, 315 |
| Multi-Purpose..... | 312 |
| Disinfectants..... | 314, 318 |
| Floor Cleaners..... | 310 |
| Floor Signs..... | 308 |
| Garbage Bags..... | 280-281 |
| Hand Cleaners | |
| Gel..... | 315, 326 |
| Liquid..... | 315, 326 |
| Lotion..... | 315, 326-327 |
| Industrial Cleaners, Multi-Purpose..... | 312 |
| Toilet Bowl Cleaners..... | 314 |
| Wringers..... | 307 |

RODO INDUSTRIES INC.

| | |
|---------------------|------|
| Folding Tables..... | 1557 |
|---------------------|------|

ROPAK

Pails 27

ROSS H. BARBER

Water Filters..... 1586

RUBBERMAID

Air Fresheners 321-322

Angled Brooms.....290

Ashtrays..... 283, 285, 383

Bathroom Faucets.....350

Broom & Mop Racks286

Buckets.....306-307

Cabinets, Storage..... 98, 381

Caddy, Waste Container.....266

Carts

Janitorial 275, 309

Laundry.....303

Changing Tables.....348

Cones, Crowd Control.....296, 308

Containers, Poly..... 27

Coolers, Containers..... 1586

Corn Brooms.....289

Dollies

Drum 244, 266

Waste Container.....266, 276-277

Dusters, Janitorial.....294, 320

Dustpans..... 290, 296

Expandable Gates.....309

Extension Poles288, 292, 294

Filing Trays..... 1577

Floor Signs.....308

Food Handling Containers.....175

Frames, Dust Mop.....294-295

Garbage Cans.....266-270, 272-275, 383, 761, 1577

Hand Scrubbers.....292

Hoppers, Self-Dumping.....171

Ladder Trucks134

Lids, Waste Container266, 268, 272, 276-277

Liners, Waste Container267, 269-270, 273, 285

Measuring Cups.....317

Microfiber Cloths.....294

Mops

Dust.....295

Wet.....294, 304, 306

Pads, Cleaning.....294

Panel Trucks.....158-159

Platform Trucks

Plastic Deck.....156-158

Semi-Live Skids.....158

Structural Foam Deck157

Portable Scales.....1494

Push Brooms.....288, 290

Recycling Containers.....276-277, 1577

Sanitary Napkin Receptacles.....349

Sheds, Portable.....381

Shelf Carts.....168

Shop Carts.....169

Stacking Bins.....26

Stacking Racks.....157

Stepstools, Polyethylene.....136, 1549

Sweepers.....286

Tilt Trucks.....172

Toilet Auto Flush Adapter.....350

Trades Carts.....169

Utility Carts.....168-169

Wagons.....157

Wheelbarrows.....172, 370

Wringers.....294, 307

RUBBERSET

Extension Poles1048

Paint Supplies

Brushes.....1047-1048

Foam Rollers.....1049

Roller Covers.....1049-1050

Rollers.....1049-1050

Trays, Paint.....1050

RUPTURESEAL

Spill Control, Leak Seal683

RUST STOP

Rust Removers.....1014, 1146

RUST-OLEUM

Caulking Guns.....1018, 1045

Cleats.....872

Coating, Hydrophobic.....1045

Floor Repair.....1018, 1045

Marking Paint.....1040

Marking Wands.....1040

Paint

Acrylic.....1044

Alkyd.....1041, 1043

Antislip.....1045

Applicator.....1040

Epoxy.....1043

Floor.....1019, 1044-1045

High Heat.....1042

Line Striping.....1039

Marking.....1038

Rubber.....1045

Sprayers, Paint.....1042

Striping Machines.....1039-1040

SAFCO

Audio-Visual Carts.....1560

Chair Caddies.....1554

Coat Racks.....1581

Coffee Equipment.....1584

Computer Desks.....1560

Desk Lamps.....1582

Ergonomic Products, Seating.....1547

Filing Cabinets

Lateral.....1565

Oversized Files.....1566

Vertical.....1565

Footrests.....1549

Hangers, Clothes.....1581

Mail Sorters.....1566

Paper Clamps, Hanging.....1565

Recycling Containers.....278

Suggestion Boxes.....1581

Task Seating.....1550, 1552

Whiteboards.....1569

SAFEBLEND

Air Fresheners.....314

Antimicrobial Soap.....326

Carpet Cleaners.....317

Detergents, Laundry.....317

Dish Detergents.....316

Disinfectants.....314, 318, 759

Floor Cleaners.....310-311

Floor Finishes.....311

Floor Sealers.....311

Floor Stripper.....311

Glass Cleaners.....315

Hand Cleaners, Lotion.....315

Industrial Cleaners, Multi-Purpose.....312

Soap Dispensers.....315

SAFECROSS

Ammonia Inhalants.....734

Antiseptics and Ointments.....748

Body Lotions.....749

Butterfly Wound Closures.....742

Coagulants.....761

Compresses.....729-732, 734-735, 743, 750

Cotton Tip Applicators.....729, 732, 747

CPR

Masks.....729-730, 762

Shields.....729-735, 762

Disposable Gloves.....729-735, 762

Elastic Bandages.....731, 740

Fabric Bandages.....734, 740

Footwear Odour Neutralizers.....750

Forceps.....751

Gauze Bandages.....729-735, 743

Hydrogen Peroxide.....748

Insect Sting Relief.....749

Isopropyl Rubbing Alcohol.....748

Kits

Burn Care.....753

First Aid.....729-739

Literature, First Aid.....729-730, 732-734

Ointments, Burn Care.....749

Plastic Bandages.....729-735, 741

Providine® Solution.....748

Splints.....731, 734, 754

Support Bandages.....731-732, 746

Tongue Depressors.....734, 747

Triangular Bandages.....729-735, 747

Tweezers, First Aid.....751

SAFETY SUPPORTS INC.

Automotive Stands.....209

Work Stands.....209

SAFETY WHIPS

Flagstaffs.....856

SALISBURY BY HONEYWELL

Arc Flash Clothing

Coats.....556

Coveralls.....556

Hoods.....556-557

Overalls.....556

Arc Flash Clothing Kits.....556-557

Faceshields.....557

Gloves, High Voltage.....558-559

SAMUEL ACME

Buckles

Plastic.....1421

Stainless Steel.....1420

Edge Protectors.....1421, 1423

Strapping

Machines & Tools.....1420-1421

Poly.....1421-1422

Stainless Steel.....1420

SANFORD CANADA

Monitor Stands.....1577

SANITAIRE BY ELECTROLUX

Vacuums, Upright.....360

SCEPTER

Containers, Poly.....671

Jerry Cans.....671-672

Transfer Pumps.....671

BRAND INDEX

SCRUBS

Wipes.....334, 338

SEBA

Flashlights, Rechargeable.....1518
Floodlights.....1526
Hand Lamps.....1526

SHARPIE

Liquid Tip Markers.....846, 1445, 1578
Permanent Markers.....1445, 1578

SHIELD FOR FIRST AID

Blankets, Burn Care.....753
Kits, Burn Care.....753
Lip Balm.....335, 384
Sunscreen.....335, 384

SHOCKWATCH

Impact Labels.....1430
Temperature Labels.....1429

SHOP VAC

Air Filters.....359
Dollies, Waste Container.....271
Garbage Cans.....271
Lids, Waste Container.....271
Portable Blowers.....359
Shop Sweepers.....286, 358
Vacuums
Accessories.....357-359, 688
Back Pack.....357
Portable.....358
Wet / Dry.....354-357, 688

SHOWA BEST GLOVE

Chemical Resistant Gloves.....584, 586-587, 590, 592
Coated Gloves.....562, 566-567, 569-570, 572-573, 593
Cut Resistant Gloves.....575-576, 578, 581
Disposable Gloves.....595, 597, 599
Heat Resistant Gloves.....624

SHURLITE

Flint Lighters.....1073
Flints.....1073

SIGNATURE FENCING

Barricades, Traffic Control.....309, 867

SKETS SAFE

Insect Repellent.....335, 384

SKY HOOK

Sky Hooks.....199

SLICE

Blades, Packaging Knife.....1441
Utility Knives.....1441

SLIDE SLEDGE

Slide Hammers.....1365

SOPER'S

Blankets, Fire Resistant.....656

SOUTHWORTH

Lift Tables.....179, 181
Pallet Lifters.....181

SPAENAUR

Flux.....1145

SPG STORAGE PRODUCT GROUP

Reel Racks.....78
Shelving Units, Steel.....78

SPIC N SPAN

Floor Cleaners.....310

SPRAYON

Aerosol Can Disposal Systems.....1037
Anti-Spatter.....1147
Anti-Static Cleaners.....1007
Brake Cleaners.....1005
CFC Free Degreasers.....319, 1003, 1007
Coil Cleaner.....1005
Contact Cleaners.....1007
Dry Lubricants, Synthetic.....1009, 1012
Dusters, Aerosol.....319, 1007
Flash Free Degreasers.....1007
Food Grade Cleaners, Non-Flammable.....1004
Food Grade Degreasers.....1004, 1007
Galvanizing Compounds.....1146-1147
Glass Cleaners.....315, 1004
Graffiti Removers.....319, 1005, 1043
Industrial Cleaners, Multi-Purpose.....319, 1004
Layout Fluids.....1148
Machinery Oil.....1011
Penetrants, Multi-Purpose.....1013
Rust Converters.....1148
Spray Lubricants.....1008-1012, 1018
Stainless Steel Cleaners.....319, 1004
Stencil Inks.....799

SQWINCHER

Sqwincher®.....648-649
Water Coolers.....650

STACKBIN

Bins, Steel.....40-41
Stacking Bins.....40-41
Stacking Racks.....41

STAEDTLER

Pencils.....1578
Permanent Markers.....1578

STANLEY BOSTITCH

Carton Staplers.....1447
Staple Removers, Packaging.....1447
Staples, Carton Staplers.....1447

STANPRO

Bay Lights.....1520
Fixtures, Light.....1520
Floodlights.....1520

STEINEL CANADA INC.

Heat Guns.....1191

STI

Fire Protection, Fire Alarm Protectors.....654
Key Boxes.....654

STORCAN

Conveyors.....224-225

STOREX

Filing Boxes.....1564

STREAMLIGHT

Batteries, C Cell.....1515
Battery Chargers.....1515
Flashlights
12 V.....1513
AA Cell.....1512-1513, 1515
AAA Cell.....1512
C Cell.....1512-1513
Hazardous Locations.....1513
N.....1513
Pocket.....1512, 1515
Rechargeable.....1513, 1515-1516, 1518
Tactical.....1512
Waterproof.....1513
Headlights, Hard Hat.....419
Lanterns
Cordless.....1516
Waterproof.....1518
Penlights.....1512
Spot Lights.....1516

STRIKE FIRST CORPORATION

Extinguishers, Fire.....651

STRONG HOLD

Cabinets, Storage.....99, 101-102
Shelving Units, Stainless Steel.....99
Shop Desks.....102
Shop Tables.....102

STRONGARM

Auto Body Repair Kits.....208
Automotive Stands.....207
Axle Jacks.....206, 208
Dollies
Mechanic's.....209
Wheel.....208
Engine Stands.....208
Garage Jacks.....206

SUMNER

Jacks, Pipe.....1115
Pipe Flange Aligners.....1115
Pipefitting Levels.....1115

SUNBEAM

Air Filters.....1500
Air Purifiers.....1500
Humidifiers.....1500

SUNLIGHT

Dish Detergents.....316

SUNNEX INC

Task Lights.....1523

SWAN

Guns, Garden Hose.....377

SWINGLINE

Shredders, Paper.....1580

SYNETIK

| | |
|----------------------------------|-----------------|
| Ergonomic Products, Seating..... | 1554 |
| Office Seating..... | 1553 |
| Task Seating..... | 209, 1134, 1553 |

TANITA

| | |
|----------------------|------|
| Weighing Scales..... | 1492 |
|----------------------|------|

TECHSTAR PLASTICS INC

| | |
|-------------------------------|---------|
| Box Trucks..... | 173-175 |
| Casters..... | 171 |
| Food Handling Containers..... | 175 |
| Hoppers, Self-Dumping..... | 171 |
| Nesting Bins..... | 18 |
| Pallets, Plastic..... | 48 |
| Recycling Containers..... | 278-279 |
| Salt & Sand Containers..... | 363 |
| Stepstands, Steel..... | 136 |
| Tanks, Storage..... | 27 |

TENSATOR

| | |
|---------------------------------|---------|
| Cones, Traffic Control..... | 863 |
| Frames, Crowd Control..... | 880 |
| Posts, Crowd Control..... | 876-879 |
| Rope, Crowd Control..... | 879 |
| Rope Ends, Crowd Control..... | 879 |
| Security, Gates..... | 878 |
| Wall Plates, Crowd Control..... | 877 |

THE ANDERSEN COMPANY

| | |
|---------------------------|--------------|
| Anti-Fatigue Matting..... | 902-903, 905 |
| Entrance Matting | |
| Pile..... | 888 |
| Rubber..... | 888 |

THE HARRIS PRODUCTS GROUP

| | |
|-----------------------------------|------|
| Cable Connectors, Welding..... | 1084 |
| Cutting Attachments, Welding..... | 1065 |
| Cutting Tips..... | 1065 |
| Cutting Torches..... | 1065 |
| Fillet Gauges..... | 1073 |
| Flux..... | 1141 |
| MIG Pliers..... | 1088 |
| Outfits, Welding..... | 1062 |
| Regulators, Welding..... | 1066 |
| Torch Handles..... | 1065 |

THE SAFETY ZONE

| | |
|------------------------------------|---------|
| Aprons..... | 529-531 |
| Boot Covers..... | 527 |
| Hair Nets..... | 526-527 |
| Hoods, General Protection..... | 527 |
| Lab Coats, General Protection..... | 531 |
| Shoe Covers..... | 527 |
| Sleeves | |
| Polypropylene..... | 528 |
| Vinyl..... | 528 |

THERMO-HEAT

| | |
|--|-----|
| High Visibility Clothing, Hat/Toque..... | 549 |
|--|-----|

THERMOID

| | |
|-------------------------------|------|
| Acetylene Hoses, Welding..... | 1075 |
| Gas Hoses, Welding..... | 1075 |
| Oxygen Hoses, Welding..... | 1075 |

TILLSON BRANDS

| | |
|-----------------------------|-----|
| Salt & Sand Containers..... | 363 |
| Scoops, Polyethylene..... | 363 |

TILTWATCH

| | |
|----------------------|------|
| Handling Labels..... | 1430 |
|----------------------|------|

TOPRING

| | |
|--|------------------|
| Adjusting Valves..... | 1232 |
| Chucks, Air..... | 1224 |
| Cut-Off Tools, Air..... | 1256 |
| Desiccant Systems..... | 1251, 1257 |
| Drains, Air..... | 1257 |
| Filter/Regulator/Coalescing Filters..... | 1257-1258, 1260 |
| Filter/Regulator/Lubricators..... | 1255, 1258-1259 |
| Filter/Regulators | 1255-1256, 1259 |
| Guns | |
| Air..... | 1225-1227, 1230 |
| Sandblasting..... | 1225 |
| Hose Fittings..... | 1234, 1247, 1250 |
| Hose Reels..... | 1234-1235 |
| Hose Whips..... | 1250 |
| Hoses, Air..... | 1234 |
| In-Line Filters..... | 1251, 1256 |
| In-Line Lubricators..... | 1251, 1256, 1261 |
| In-Line Regulators..... | 1232, 1256, 1261 |
| Manifolds, Air..... | 1250 |
| Non-Sparking Tools, Wrenches..... | 1256 |
| Pneumatic Pipe Fittings..... | 1247 |
| Pneumatic Tube Fittings..... | 1248 |
| Pressure Gauges, Tire..... | 1224 |
| Quick Couplers..... | 1246, 1248-1250 |
| Tire Inflator Gauges..... | 1224 |
| Tire Pressure Gauges..... | 1224 |
| Vacuums, Accessories..... | 1225 |
| Valves, Safety..... | 1232, 1257 |

TORK

| | |
|------------------------------|--------------|
| Hand Towels..... | 341 |
| Paper Towel Dispensers..... | 341-343 |
| Paper Towels..... | 341-344, 346 |
| Toilet Paper..... | 346 |
| Toilet Paper Dispensers..... | 346-347 |
| Wipes..... | 339 |
| Wipes Dispensers..... | 339 |

TRACTEL

| | |
|---------------------|-----|
| Hoists, Manual..... | 199 |
|---------------------|-----|

TRAMEX

| | |
|----------------------|------|
| Moisture Meters..... | 1477 |
|----------------------|------|

TREND-PAK

| | |
|-------------------|------|
| Postal Tubes..... | 1434 |
|-------------------|------|

TRI LITE MARS

| | |
|----------------------------------|---------|
| Dock Lights | |
| Double Strut..... | 219 |
| Flexible..... | 218-219 |
| Incandescent..... | 219 |
| Single Strut..... | 219 |
| Stop & Go..... | 220 |
| Halogen Lamps / Light Bulbs..... | 219 |
| LED Lamps / Light Bulbs..... | 219 |

TRI-ARC MANUFACTURING

| | |
|----------------------|---------|
| Rolling Ladders..... | 138-140 |
|----------------------|---------|

TRI-FLOW

| | |
|-----------------------|------------|
| Spray Lubricants..... | 1008, 1010 |
|-----------------------|------------|

TRIPP LITE

| | |
|-------------------------|------|
| Power Strips, GFCI..... | 1542 |
| UPS Systems..... | 1542 |

TRUE TEMPER

| | |
|-------------------|-----|
| Wheelbarrows..... | 370 |
|-------------------|-----|

TRUMETER

| | |
|-------------------------|------------------|
| Measuring Counters..... | 1484 |
| Measuring Wheels..... | 1278, 1482, 1484 |
| Ratchet Counters..... | 1483 |

TUFF TIE

| | |
|-----------------|------|
| Cable Ties..... | 1435 |
|-----------------|------|

TYDEN BROOKS

| | |
|-------------------|------|
| Tamper Seals..... | 1451 |
|-------------------|------|

TYROLIT

| | |
|-------------------------------|----------|
| Cut-Off Wheels..... | 912, 914 |
| Flap Discs..... | 919 |
| Grinding Wheels, Type 27..... | 912, 916 |

ULTRATECH

| | |
|------------------------------------|--------------|
| Berms, Spill Control..... | 681 |
| Cable Protectors, Office..... | 218 |
| Drain Protectors..... | 682 |
| Drain Seals..... | 681-682 |
| Drum Equipment, Spill Pallets..... | 704-705, 710 |
| Shovels, Spill Control..... | 686 |

UNION BUTTERFIELD

| | |
|-----------------------|---------|
| Countersinks..... | 962 |
| Hand Taps..... | 956-957 |
| Screw Extractors..... | 960 |
| Tap Wrenches..... | 960 |

UNIROPE

| | |
|--------------------|-----|
| Slings, Nylon..... | 188 |
|--------------------|-----|

URBAN IMAGES

| | |
|-----------------------------|-----|
| Salt & Sand Containers..... | 363 |
|-----------------------------|-----|

UTICA

| | |
|--------------------------|------|
| Torque Screwdrivers..... | 1329 |
|--------------------------|------|

UVEX BY HONEYWELL

| | |
|-------------------------------|---------------|
| Faceshields..... | 411 |
| Glasses, Safety..... | 391-396 |
| Goggles, Safety..... | 404-406, 1120 |
| Solutions, Lens Cleaning..... | 409 |
| Stations, Lens Cleaning..... | 409 |
| Tissues, Lens Cleaning..... | 409 |

VALLEYCRAFT

| | |
|---------------------------|----------|
| Dollies, Drum..... | 244, 702 |
| Lifters, Drum..... | 238 |
| Pallets, Plastic..... | 46 |
| Shelf Carts..... | 161 |
| Workbenches, Folding..... | 121 |

VENREZ

| | |
|----------------------|------|
| Stacking Chairs..... | 1555 |
|----------------------|------|

VERTEX STANDARD

| | |
|---------------------|-----|
| Two-Way Radios..... | 442 |
|---------------------|-----|

BRAND INDEX

VESTIL

| | |
|--------------------------------------|----------|
| Agricultural Jacks..... | 207 |
| Bollards..... | 87 |
| Dollies | |
| Drum..... | 244 |
| Mechanic's..... | 209 |
| Polyethylene..... | 177 |
| Wheel..... | 177 |
| Extensions, Forklift..... | 187 |
| Lift Tables..... | 178, 181 |
| Lifters, Drum..... | 242-243 |
| Machinery Rollers..... | 205 |
| Openers, Pail..... | 250 |
| Pallet Trucks..... | 186 |
| Pallets, Aluminum..... | 48 |
| Pry Dollies..... | 177 |
| Security, Gates..... | 216 |
| Shelving Units, Stainless Steel..... | 78 |
| Stairway Ladders..... | 140 |
| Sweepers..... | 286 |
| Wire Spool Carts..... | 167 |
| Work Positioners..... | 181 |

VIBRASYSTEMS

| | |
|---------------------------|------|
| Anti-Vibration Pads..... | 1272 |
| Cupmounts..... | 1272 |
| Isolators, Vibration..... | 1272 |
| Leveling Mounts..... | 1272 |

VIKING

| | |
|---|----------|
| Flame Resistant Clothing, Rainwear..... | 542, 548 |
| Flame Retardant Clothing, Jackets..... | 542, 548 |
| High Visibility Clothing | |
| Jackets..... | 547-548 |
| Pants..... | 548 |
| Parkas..... | 547 |
| Sweatshirts..... | 547 |
| T-Shirts..... | 547 |
| Vests..... | 546-547 |
| Hoods, Rain..... | 542, 548 |
| Jackets, Rain..... | 542, 551 |
| Overalls, Rain..... | 542 |
| Pants, Rain..... | 551-552 |
| Parkas..... | 552 |
| Seat Cover, Automotive..... | 546 |
| Vests, Traffic Control..... | 545-546 |
| Work Boots..... | 633 |

WAGNER

| | |
|----------------------|------|
| Guns, Air..... | 1051 |
| Sprayers, Paint..... | 1051 |

WALTER SURFACE TECHNOLOGIES

| | |
|--------------------------------|-----------|
| Anti-Spatter..... | 1147 |
| Cutting Fluids | |
| for all Metals..... | 1148-1149 |
| for Steel..... | 1148 |
| Degreasers, Multi-Purpose..... | 319, 1003 |
| Food Grade Degreasers..... | 1004 |

WATERLOO

| | |
|---------------|-----------|
| Tool Storage | |
| Boxes..... | 1394 |
| Cabinets..... | 1395 |
| Chests..... | 1394-1395 |

WD-40

| | |
|-------------------------------|------------|
| 3-in-1..... | 1012 |
| Dry Lubricants, Silicone..... | 1010 |
| Engine Degreasers..... | 1015 |
| Spray Lubricants..... | 1011, 1018 |
| WD-40®..... | 1004, 1013 |

WEARWELL

| | |
|--------------------------------|-------------------------------------|
| Anti-Fatigue Matting..... | 891-894, 896-897, 899-900, 905, 907 |
| Anti-Static Matting..... | 560, 903-904 |
| Entrance Matting | |
| Rubber..... | 888 |
| Vinyl..... | 901 |
| Eyewash Stations, Matting..... | 727, 893 |
| Grounding Mats..... | 904 |
| Matting, Welding..... | 904, 1119 |

WELD-AID

| | |
|-------------------|------|
| Anti-Spatter..... | 1143 |
|-------------------|------|

WELDCOTE METALS

| | |
|---------------------------|-----------------|
| Brazing Alloys..... | 1139 |
| Flux..... | 1141 |
| MIG Wire | |
| Bronze..... | 1138 |
| Copper..... | 1138 |
| Steel..... | 1135, 1137 |
| Plasma Cutter Guides..... | 1069 |
| Solder..... | 1140 |
| Stick Electrodes..... | 1136-1137, 1139 |
| TIG Rods..... | 1136-1138, 1140 |

WELDCRAFT

| | |
|--------------------------------------|-----------|
| Air (Gas) Cooled Torches..... | 1101 |
| Alumina Nozzles..... | 1104-1106 |
| Back Caps, TIG Torch..... | 1108 |
| Collet Bodies, TIG Torch..... | 1107-1109 |
| Collets, TIG Torch..... | 1105-1109 |
| Gas Hoses, Welding..... | 1110 |
| Insulators, TIG Torch..... | 1108 |
| Lava Nozzles..... | 1105 |
| Power Cable Adapters, TIG Torch..... | 1109 |
| Power Cables, TIG Torch..... | 1110 |
| Water Cooled Torches..... | 1103-1105 |
| Water Hoses, Welding..... | 1110 |

WELD-MATE

| | |
|--------------------------------|--------------------|
| Air (Gas) Cooled Torches..... | 1101 |
| Alumina Nozzles..... | 1106 |
| Aprons, Leather..... | 1132 |
| Back Caps, TIG Torch..... | 1108 |
| Beanies, Welding..... | 1133 |
| Bibs, Leather..... | 1132 |
| Blankets, Welding..... | 1118 |
| Cable Connectors, Welding..... | 1084-1085 |
| Cable Lugs, Welding..... | 1085 |
| Cable Protectors, Welding..... | 1110 |
| Casters..... | 1119 |
| Chaps, Welding..... | 1132 |
| Chipping Hammers, Welding..... | 1087 |
| Collet Bodies, TIG Torch..... | 1107-1108 |
| Collets, TIG Torch..... | 1107 |
| Conductor Tubes, MIG Gun..... | 1096 |
| Contact Tips, MIG Gun..... | 1094-1097 |
| Cutting Tips..... | 1070-1071 |
| Diffusers, MIG Gun..... | 1095-1097 |
| Electrode Holders..... | 1084 |
| Flint Lighters..... | 1073 |
| Flints..... | 1073 |
| Gas Hoses, Welding..... | 1110 |
| Gloves, Welding..... | 619-621, 1129-1131 |
| Goggles, Welding..... | 1120 |
| Gouging Electrodes..... | 1087 |
| Gouging Torches..... | 1087 |
| Ground Clamps, Welding..... | 1086 |
| Hand Pads..... | 621, 1131 |
| Head Assemblies, MIG Gun..... | 1095 |
| Helmets, Welding..... | 1123 |
| Insulators, TIG Torch..... | 1108 |
| Jackets, Leather..... | 1132 |
| Lava Nozzles..... | 1105 |
| Liners, MIG Gun..... | 1095-1097 |

| | |
|--------------------------------------|------------|
| Magnifier Plates..... | 1128 |
| MIG Guns..... | 1094-1096 |
| MIG Pliers..... | 1088 |
| MIG Wire, Steel..... | 1135 |
| Nozzle Reamers..... | 1088 |
| Nozzles, MIG Gun..... | 1095-1097 |
| O-Rings, MIG Gun..... | 1095 |
| Power Cable Adapters, TIG Torch..... | 1109 |
| Power Cables, TIG Torch..... | 1110 |
| Pressure Gauges, Dry..... | 1068 |
| Retaining Rings, MIG Gun..... | 1095 |
| Rod / Electrode Containers..... | 1089, 1134 |
| Scratch Brushes..... | 947, 1087 |
| Screens, Welding..... | 1119 |
| Sleeves, Welding..... | 1132 |
| Soapstone..... | 1143 |
| Spats, Welding..... | 1132 |
| Squares, Welding..... | 1086 |
| Sweatbands..... | 420, 1133 |
| Tip Cleaners..... | 1073 |
| Tip Refacers..... | 1073 |
| Triggers, MIG Gun..... | 1095 |
| Water Cooled Torches..... | 1103 |
| Water Hoses, Welding..... | 1110 |

WELLER

| | |
|-------------------------|-----------|
| Butane Torches..... | 1080 |
| Soldering Guns..... | 1080-1082 |
| Soldering Irons..... | 1080-1082 |
| Soldering Stations..... | 1082 |

WESCO

| | |
|---------------------------|------------------|
| Extensions, Forklift..... | 242 |
| Gauges, Drum..... | 251 |
| Hand Trucks..... | 149-151 |
| Lift Tables..... | 179, 184 |
| Lifters, Drum..... | 238-239, 242-243 |
| Pallet Lifters..... | 184 |
| Pallet Trucks..... | 185-186 |
| Stackers..... | 180 |
| Trucks, Drum..... | 247 |

WESTCOTT

| | |
|-----------------|------|
| Clipboards..... | 1579 |
|-----------------|------|

WESTERN ENTERPRISES

| | |
|--------------------------------|------|
| Flashback Arrestors..... | 1074 |
| Hose Repair Kits, Welding..... | 1075 |
| Propane Torches..... | 1064 |
| Quick-Connects, Welding..... | 1074 |
| Y Connections, Hose..... | 1074 |

WHITE LIGHTNING

| | |
|-------------------------|------|
| Caulk..... | 1025 |
| Sealants, Silicone..... | 1025 |

WILTON

| | |
|------------------------|------|
| Angle Vises..... | 1295 |
| Bar Clamps..... | 1287 |
| Bench Vises..... | 1294 |
| C-Clamps..... | 1289 |
| Drill Press Vises..... | 1295 |
| Machine Vises..... | 1295 |
| Quick Clamps..... | 1288 |
| Tilting Vises..... | 1295 |

WINDEX

| | |
|---------------------|-----|
| Glass Cleaners..... | 315 |
|---------------------|-----|

WIPECO

| | |
|-----------------------|-----------|
| Paint Supplies | |
| Accessories..... | 1054 |
| Cloths..... | 1054 |
| Drop Sheets..... | 1054 |
| Rags..... | 338, 1054 |

WISS

| | |
|---------------------------------|-----------|
| Fabric Shears..... | 1357 |
| Hand Crimpers, HVAC..... | 1359 |
| Hand Seamers, HVAC..... | 1359 |
| Nippers, End Cut..... | 1357 |
| Scissors | |
| Electrician..... | 1357 |
| General Purpose..... | 1356 |
| Industrial..... | 1356-1357 |
| Shears, Industrial..... | 1356 |
| Snips | |
| All Purpose..... | 1357-1359 |
| Duckbill..... | 1357 |
| Grape & Orchard..... | 1357 |
| Metal Cutting..... | 1358-1359 |

WMH TOOL GROUP INC.

| | |
|------------------------|------|
| Bar Clamps..... | 1284 |
|------------------------|------|

WOBBLELIGHT

| | |
|-------------------------|------|
| Task Lights..... | 1529 |
|-------------------------|------|

WOODHEAD CANADA LTD

| | |
|----------------------------|-----|
| Tool Balancers..... | 203 |
|----------------------------|-----|

WORKSMAN

| | |
|-----------------------|-----|
| Tricycles..... | 161 |
|-----------------------|-----|

WORLD DRYER

| | |
|-------------------------|-----|
| Hand Dryers..... | 351 |
|-------------------------|-----|

ZENITH SAFETY PRODUCTS

| | |
|--|------------------|
| Absorbents..... | 684-685, 691-692 |
| Anti-Fatigue Matting..... | 894, 902 |
| Anti-Skid Tape..... | 872 |
| Anti-slip Snow Shoes..... | 636 |
| Aprons..... | 530, 533 |
| Arm / Leg Bands, Traffic Control..... | 548 |
| Back Supports..... | 641 |

| | |
|--|---|
| Barricade Tape..... | 868 |
| Barricades, Traffic Control..... | 83, 867, 874 |
| Bars, Traffic Cone..... | 863 |
| Base, Crowd Control..... | 874 |
| Battery Acid Neutralizers..... | 686 |
| Blankets, Fire Resistant..... | 656 |
| Booms, Spill Control..... | 679 |
| Boot Sanitizer..... | 907 |
| Chemical Resistant Gloves..... | 583-584, 586-588, 590-592 |
| Circular Saws, Framing..... | 872 |
| Clean Room Matting..... | 907 |
| Cleats..... | 872 |
| Coated Gloves..... | 562-568, 570-574, 578, 591-592, 627-628 |
| Cones, Traffic Control..... | 862 |
| Convex Mirrors..... | 882 |
| Coveralls, General Protection..... | 532-533, 689-693, 697 |
| Cut Resistant Gloves..... | 575, 613 |
| Delineators, Traffic Control..... | 863 |
| Disposable Dust Masks..... | 447 |
| Disposable Gloves..... | 594-595, 597-600 |
| Disposable Respirators..... | 447 |
| Dollies, Drum..... | 244, 702 |
| Dome Mirrors..... | 881, 883 |
| Drain Protectors..... | 682 |
| Drain Seals..... | 682 |
| Drip Pans..... | 252, 680 |
| Entrance Matting | |
| Rubber..... | 888 |
| Vinyl..... | 901 |
| Ergonomic Products, Gloves..... | 601 |
| Face Mask..... | 447 |
| Flame Resistant Clothing, Rainwear..... | 541 |
| Flat Mirrors..... | 882 |
| Folding Gates..... | 83, 309, 867 |
| Foot Guards | |
| Plastic..... | 637 |
| Steel..... | 637 |
| Glasses | |
| Cases..... | 407 |
| Cord Retainers..... | 408 |
| Safety..... | 386-390 |
| Gloves | |
| Canvas Cotton..... | 628 |
| Cotton..... | 612 |
| Goggles, Safety..... | 404, 412, 689-697 |
| Hair Nets..... | 526 |
| Hard Hats..... | 418 |
| Harnesses, Traffic Control..... | 548 |
| Hazardous Materials Cabinets..... | 658 |
| Heat Resistant Gloves..... | 623-624 |
| High Visibility Clothing | |
| T-Shirts..... | 547 |
| Vests..... | 545 |
| Inspection Gloves..... | 625 |

| | |
|--|-----------------------------|
| Jersey Gloves..... | 628-629 |
| Kits, Spill Control..... | 689-698 |
| Knit Gloves..... | 626 |
| Lab Coats, General Protection..... | 532-533 |
| Leather Gloves..... | 608-613, 618 |
| Megaphones..... | 444 |
| Neutralizers, Spill Control..... | 686, 697 |
| Pads, Spill Control..... | 673-678, 680 |
| Parking Curbs, Traffic Control..... | 861 |
| Pillows, Spill Control..... | 680 |
| Posts, Crowd Control..... | 874-875 |
| Rag Rugs, Spill Control..... | 679 |
| Rolls, Spill Control..... | 673-678, 689-690 |
| Scoops, Polypropylene..... | 694 |
| Shoe Covers..... | 527 |
| Sleeves | |
| Cotton..... | 528 |
| Vinyl..... | 528 |
| Socks, Spill Control..... | 680 |
| Solutions, Lens Cleaning..... | 409 |
| Speed Bumps, Traffic Control..... | 860 |
| Stations, Lens Cleaning..... | 409 |
| Suits, Rain..... | 540 |
| Toe Guards..... | 637 |
| Towellettes, Lens Cleaning..... | 409, 465, 760 |
| Vests, Traffic Control..... | 545 |
| Waiver's / Parade Gloves..... | 625 |
| Wall Plates, Crowd Control..... | 875 |
| Winter Lined Gloves..... | 549, 571, 609, 611, 613-618 |
| Winter Liners..... | 418, 553 |

ZIPWALL

| | |
|-----------------------|------|
| Paint Supplies | |
| Wall Barriers..... | 1054 |

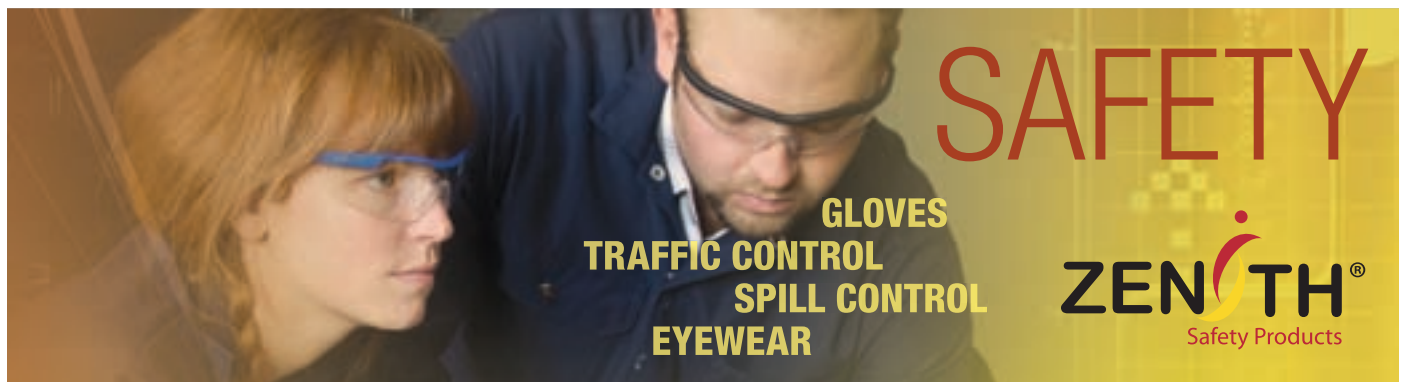

-A-

Abrasives

| | |
|---------------------------------------|-----------------------------------|
| Backing Pads..... | 921-922, 925, 927, 935 |
| Benchstand Belts..... | 929 |
| Bristle Brushes..... | 921, 1271 |
| Bristle Discs..... | 921 |
| Buffing Compounds..... | 937 |
| Buffing Wheels..... | 937 |
| Cartridge Rolls..... | 929 |
| Crimped Filament Wheels..... | 912-913 |
| Cup Brushes..... | 945 |
| Cut & Polish Wheels..... | 938 |
| Cut-Off Wheels..... | 912-916 |
| Deburring Wheels..... | 936, 938, 1271 |
| Disc Holder Pads..... | 922-925, 927, 935-936, 938 |
| End Brushes..... | 940, 942, 944 |
| Files..... | 1302-1307 |
| Finishing Wheels..... | 938 |
| Flap Brushes..... | 937 |
| Flap Discs..... | 918-919 |
| Flap Wheels..... | 919-920, 937 |
| Grinding Wheels..... | 912-917, 1271 |
| Grip-On Discs..... | 926 |
| Portable Belts..... | 928 |
| Portable File Belts..... | 928 |
| Rasps..... | 1305 |
| Resin Fibre Discs..... | 922-923, 925 |
| Rolo™ / Power-Lock Discs..... | 924-925, 935 |
| Sanding Sponges..... | 933 |
| Sandpaper..... | 930-932 |
| Scratch Brushes..... | 946-947, 1087 |
| Spiral Bands..... | 929 |
| Stick-On Discs..... | 926-927 |
| Surface Conditioning Belts..... | 937 |
| Surface Conditioning Discs..... | 934-936, 938 |
| Surface Conditioning Pads..... | 302, 933-934, 938 |
| Surface Conditioning Rolls..... | 930, 933-934 |
| Tube Brushes..... | 945 |
| Wheel Brushes..... | 941-944, 1271 |
| Absorbents | 684-685, 691-692 |
| Accelerators, Adhesive | 1032 |
| Accident Prevention Tags | 786-788, 790 |
| Acetaminophen | 752 |
| Acetone | 1037 |
| Acetylene Hoses, Welding | 1075 |
| Acrylic Coating | 1040, 1042-1044 |
| Acrylic Paint | 1040, 1042-1044 |
| Adapters, Power Cable | 1109 |
| Adaptors, Pipe Thread | 1240 |
| ADF Filters | 1121, 1124-1126 |
| Adhesive Bandages | 741 |
| Adhesives | |
| Accelerators..... | 1032 |
| Acrylic..... | 1034 |
| All Purpose..... | 1023 |
| Carpenters' Glue..... | 1029 |
| Caulk..... | 1025 |
| Caulking Guns..... | 1018, 1023-1024, 1035, 1045, 1161 |
| Construction & Floor..... | 1029 |
| Contact Cement..... | 1029 |
| Epoxies..... | 1020-1021, 1023, 1033-1034 |
| Epoxy Applicators..... | 1021, 1035 |
| Floor Repair..... | 1018-1019, 1045 |
| Floor Sealers..... | 1019 |
| Glue Guns..... | 1035-1036, 1418 |
| Glue Sticks..... | 1036, 1418 |
| Instant..... | 1031-1032 |
| Pipe Cements..... | 1022 |
| Plumbers' Putty..... | 1022 |
| Primers..... | 1032 |
| Spray..... | 1036, 1418 |
| Spreaders..... | 1053 |
| Structural..... | 1032-1034 |
| Tape..... | 1020, 1415 |
| White Glue..... | 1029 |
| Wood Glue..... | 1029 |
| Adjustable Reamers | 985 |

| | |
|---|--|
| Adjustable Wrenches | 1309-1312, 1330, 1332 |
| Adjusting Valves | 1232 |
| Admittance Signs | 803-810, 813 |
| Aerosol Can Disposal Systems | 1037 |
| Agricultural Jacks | 207-208 |
| Air (Gas) Cooled Torches | 1101, 1103-1104 |
| Air Conditioners | 1500 |
| Air Filters | 359, 1058, 1500, 1506 |
| Air Fresheners | 314, 321-322 |
| Air Operated Pumps | 258 |
| Air Products | |
| Adjusting Valves..... | 1232 |
| Air Dryers..... | 1251, 1257 |
| Ball Valves..... | 1231 |
| Butterfly Valves..... | 1231 |
| Chucks..... | 1224 |
| Compressors..... | 1262-1265 |
| Cut-Off Tools..... | 1204 |
| Drains..... | 1257 |
| Filters..... | 1251, 1255-1260 |
| Guns..... | 1035, 1051, 1225-1230 |
| Hose Fittings..... | 1234, 1239, 1247, 1250 |
| Hose Reel Carts..... | 1237 |
| Hose Reels..... | 1076, 1234-1237, 1532 |
| Hose Whips..... | 1250 |
| Hoses..... | 1207, 1233-1235 |
| In-Line Regulators..... | 1232, 1256, 1261 |
| Lubricators..... | 1251, 1256, 1261 |
| Manifolds..... | 1250 |
| Pipe Fittings..... | 1228, 1240-1244, 1247 |
| Piping..... | 81 |
| Pressure Gauges..... | 1058, 1224 |
| Quick Couplers..... | 1207, 1233, 1246, 1248-1250 |
| Safety Valves..... | 1232, 1257 |
| Tire Inflator Gauges..... | 1224 |
| Tube Fittings..... | 1239, 1248 |
| Tubing..... | 1239 |
| Air Purifiers | 1500 |
| Air Quality Monitors | 487, 1474 |
| Air Tool Oil | 1037, 1261 |
| Air Tools | |
| Buffers..... | 1221 |
| Chippers..... | 1088, 1207, 1213 |
| Drills..... | 1205, 1209, 1221-1223 |
| Engravers..... | 1212, 1223 |
| Grinders..... | 1204, 1211-1212, 1215, 1220, 1222-1223 |
| Hammers..... | 1213 |
| Sanders..... | 1207, 1211-1213, 1216-1221 |
| Saws..... | 1214 |
| Scalers..... | 1207, 1214 |
| Screwdrivers..... | 1207, 1209, 1211, 1222 |
| Shears..... | 1214 |
| Wrenches..... | 1205-1206, 1208, 1210, 1214, 1222 |
| Aircraft Cables | 194 |
| Airport Windsocks | 871 |
| Airway Kits | 763 |
| Aisle Marking Tape | 869-870 |
| Aisle Signs | 12, 48 |
| Alarms, Smoke | 655 |
| Aligners, Pipe Flange | 1115-1116 |
| Aligning Punches | 1369 |
| Alkyd Coating | 1040-1041, 1043-1044 |
| Alkyd Paint | 1040-1041, 1043-1044 |
| Alligator Clips | 1460, 1463 |
| Alloys, Brazing | 1139 |
| Alumina Nozzles | 1104-1106 |
| Aluminized Gloves | 624 |
| Aluminum Cleaners | 1145 |
| Aluminum Foil | 1583 |
| Aluminum Foil Tape | 1020, 1415 |
| Ambient Air Pump Respirators | 466, 481, 1127 |
| Ammonia Inhalants | 734, 763 |
| Anchorage Connectors | 516-517, 519 |
| Anchors | |
| Beam Clamp..... | 517 |
| Cross-Arm Strap..... | 519, 560 |
| D-Bolt..... | 516, 519 |
| Friction Bolt..... | 516 |

| | |
|---|------------------------|
| Anemometers | |
| Integral Probe..... | 1486-1487 |
| Vane..... | 1486 |
| Angle Clamps | 1285 |
| Angle Drills | |
| Air..... | 1222 |
| Electric..... | 1184 |
| Angle Grinders | |
| Air..... | 1204, 1211, 1215, 1222 |
| Electric..... | 916, 1163, 1168-1171 |
| Angle Vises | 1295 |
| Angle Wrenches | 1335 |
| Angled Brooms | 290 |
| Annular Cutters | 972, 1193 |
| Antibacterial Soap | 324-325, 329, 332 |
| Antibacterial Wipes | 318, 465, 759-760 |
| Anti-Fatigue Matting | 891-909 |
| Anti-Freeze | 1144 |
| Anti-inflammatory | 752 |
| Antimicrobial Soap | 326 |
| Anti-Seize | 1016 |
| Antiseptics | |
| Benzalkonium Towelettes..... | 729-735, 748 |
| Dettol™..... | 748 |
| Hydrogen Peroxide..... | 734, 748, 759 |
| Isopropyl Rubbing Alcohol..... | 748 |
| Providine® Solution..... | 748 |
| Antiseptics and Ointments | 729-732, 745, 748-749 |
| Anti-Skid Cleats | 872 |
| Anti-Skid Tape | 872-873 |
| Antislip Floor Coating | 1045 |
| Anti-Slip Floor Coatings | 873, 1019 |
| Antislip Floor Paint | 1045 |
| Anti-slip Snow Shoes | 636 |
| Anti-Spatter | 1143, 1145, 1147 |
| Anti-Static Cleaners | 1007 |
| Anti-Static Matting | 560, 903-904 |
| Anti-Vibration Gloves | 606-607 |
| Anti-Vibration Hammers | 1364-1365 |
| Anti-Vibration Pads | 1272 |
| Appliance Trucks | 150, 1454 |
| Aprons | |
| Chemical Resistant..... | 530-531, 533 |
| General Protection..... | 529, 534 |
| Heat Resistant..... | 551 |
| Leather..... | 1132 |
| Limited Use..... | 530-531, 533 |
| Tool..... | 1391 |
| Welding..... | 1132 |
| Arbor Presses | 208 |
| Arbors, Hole Saw | 1193, 1198 |
| Arc Flash Clothing | |
| Coats..... | 556 |
| Coveralls..... | 554-556 |
| Hoods..... | 556-557 |
| Jackets..... | 555 |
| Overalls..... | 555-556 |
| Pants..... | 554 |
| Shirts..... | 554 |
| Arc Flash Clothing Kits | 556-557 |
| Arc Rated Harness | 500, 560 |
| Arc Rated Lanyards | 510, 560 |
| Archive, Shelving | 57 |
| Arm, Splints | 731, 734, 754 |
| Arm / Leg Bands, Traffic Control | 548 |
| Arrestors, Welding Torch | 1074 |
| Ashtrays | 236, 283-285, 383, 657 |
| Audio-Visual Carts | 1560-1561 |
| Auger Bits | 1199 |
| Augers | |
| Drain..... | 1375 |
| Toilet..... | 1375 |
| Auto Body Repair Kits | 208 |
| Auto-Ignite Torches | 1064 |
| Automatic Brake Winches | 195 |
| Automotive | |
| Carburetor Cleaner..... | 1015 |
| Windshield De-Icer..... | 1015 |
| Automotive Cleaners | |
| Diesel Conditioner..... | 1015 |
| Automotive Seat Cover | 280, 546 |
| Automotive Stands | 207, 209 |

| | |
|--|--|
| Axes | |
| All-Purpose..... | 368 |
| Carpenter..... | 368 |
| Axial Blowers | 488-489 |
| Axle Jacks | 206, 208 |
| -B- | |
| Back Caps, TIG Torch | 1108 |
| Back Supports | 641-642 |
| Backboard, Spinal | 755 |
| Backing Pads | 921-922, 925, 927, 935 |
| Backpack, Hydration | 647 |
| Bag Sealing Tape | 1436 |
| Bags | |
| Garbage..... | 278, 280-282, 348-349, 383, 761 |
| Laundry..... | 303 |
| Paper..... | 1435 |
| Poly..... | 1436 |
| Static..... | 1435 |
| Tire..... | 280 |
| Tool..... | 1391-1393, 1464 |
| Balaclavas | 553 |
| Balancers, Tool | 203 |
| Ball Pein Hammers | |
| Anti-Vibration..... | 1365 |
| Fiberglass Handle..... | 1365 |
| Non-Sparking..... | 1380 |
| Wood Handle..... | 1309-1310, 1312, 1362, 1365 |
| Ball Valve Lockouts | 780, 782-784 |
| Ball Valves | 1231 |
| Balometers | 1488 |
| Bandages | |
| Adhesive..... | 741 |
| Butterfly Wound Closures..... | 742 |
| Compresses..... | 729-730, 734-735, 743, 746 |
| Elastic..... | 731, 740, 746 |
| Fabric..... | 734, 740-742, 745 |
| Gauze..... | 729-735, 743 |
| Plastic..... | 729-735, 741-742, 745 |
| Plastic Strips..... | 734, 742 |
| Self-Stick..... | 742, 746 |
| Spray..... | 742 |
| Support..... | 731-732, 746 |
| Transparent..... | 741 |
| Triangular..... | 729-735, 747 |
| Wound Closures..... | 742, 745 |
| Banding Film | 1425 |
| Bands | |
| Hearing..... | 430-431 |
| Spiral..... | 929 |
| Bandsaws | |
| Metal Cutting..... | 1178 |
| Wood Cutting..... | 1178 |
| Bankers® Boxes | 1564 |
| Banners, Traffic Control | 859 |
| Bar, Grab | 350 |
| Bar Clamps | 1284-1287 |
| Bar Magnets | 1298 |
| Bar Racks | 53 |
| Barricade Tape | 868 |
| Barricades, Traffic Control | 83, 309, 867, 874 |
| Bars | |
| Cargo..... | 212, 1457 |
| Crowbars..... | 368, 1380 |
| Jack..... | 1457 |
| Pinch..... | 1367, 1380 |
| Power..... | 1541 |
| Pry..... | 1309-1312, 1340, 1366-1367, 1380, 1386 |
| Rolling Head..... | 1367 |
| Traffic Cone..... | 863 |
| Wrecking..... | 1366 |
| Base, Crowd Control | 874 |
| Basins | 731, 734, 751, 758 |
| Baskets, Dipping | 992 |
| Bathroom Faucets | 350 |
| Bathroom Mirrors | 350 |
| Baths, Eye | 728, 734 |

| | | | |
|---|---|--|--|
| Baton Light858, 860 | Drill948-955, 963-972,1193, 1196, 1198-1199 | Boxes | Bushings, Pipe Thread1240, 1243 |
| Batteries | Forstner1199-1200 | Corrugated Paper1431 | Butane Torches1080, 1083 |
| 1.5 Volt.....1507 | Hammer1195-1196 | Filing.....1564 | Butterfly Valve Lockouts783 |
| 12 Volt.....1507, 1522 | Hex1344 | Jobsite.....36, 1394, 1401-1407 | Butterfly Valves1231 |
| 3 Volt.....1507, 1515 | Hex Square Drives1340, 1343 | Key.....654 | Butterfly Wound Closures742 |
| 6 Volt.....223, 1470, 1507, 1517, 1522 | Nutsetters1343 | Mailboxes.....1576 | |
| 9 Volt.....655, 1507 | Posidriv®1345 | Mailers.....1434 | |
| AA Cell.....419, 444, 1507,1509, 1511-1512, 1514-1519,1529, 1572-1574 | Prentice969-970 | MSDS.....667 | |
| AAA Cell.....1507, 1509-1510, 1519, 1572 | Rotary Hammer1195 | Outlet.....1539 | |
| C Cell.....444, 1507, 1515-1516, 1518 | Slotted1344-1345 | Suggestion.....1581 | |
| Cordless Power Tools.....1156-1164, 1167 | Square Recess1344-1345 | Tool Storage.....1309-1311, 1393-1394 | |
| D Cell.....866, 1507, 1509-1510, 1517-1518 | Torque1343 | | |
| Battery Acid Neutralizers686, 1037 | Torx®1343-1344 | Braces, Tennis Elbow643 | |
| Battery Chargers1167, 1507, 1515 | Tri-Wing1344 | Brackets, Gas Cylinder1079 | |
| Cordless Drill.....1167 | Blacksmiths' Hammers1366 | Brake Cleaners1005, 1015 | |
| Flashlight.....1515 | Blade Disposal Case1438 | Brakes, Caster231 | |
| Battery Cleaners1015 | Blades | Brass Hammers1365 | |
| Battery Coolant Checkers1490 | Circular Saw.....914, 1202-1203 | Brass Tags793 | |
| Battery Equalizers1037 | Combination Saw.....1203 | Brazing Alloys1139 | |
| Bay Lights1520 | Cut-Off.....1203 | Brazing Tips1064 | |
| Beaded Chain794 | Mitre Saw.....1203 | Breaker Hammers1187 | |
| Beam Clamp Anchors517 | Packaging Knife.....1425, 1430, 1434, 1438-1442 | Brick Hammers1364 | |
| Beam Clamps199, 519 | Razor.....1052 | Bristle Brushes921, 1271 | |
| Beam Trolleys190, 519 | Reciprocating Saw.....1201 | Bristle Discs921 | |
| Beams, Decking & Shoring212, 1457 | Blank Tags791-793, 1448 | Broadcast Spreaders364, 370 | |
| Beanies, Welding1125, 1133 | Blankets | Broom & Mop Racks286 | |
| Bearing Greases1017 | Burn Care.....753 | Brooms | |
| Belt Dressing1012 | Emergency.....756 | Angled.....290 | |
| Belt Holsters, Flashlight1509-1511 | Fire Resistant.....656, 753 | Corn.....289-290 | |
| Belt Sanders | First Aid.....729, 732, 756-757 | Magnetic.....290 | |
| Air.....1213, 1216-1217, 1220-1221 | Moving.....1454 | Push.....287-290, 301 | |
| Electric.....1180 | Welding.....1118 | Spill Control.....687 | |
| Belts | Blast Cabinets1056-1057 | Switch.....290 | |
| Benchstand.....929 | Bleach314 | Water.....377 | |
| Portable.....928 | Blood Pressure Monitors756 | Brushes | |
| Portable File.....928 | Blow Guns1225-1227, 1230 | Acid.....1141, 1145 | |
| Surface Conditioning.....937 | Blowers | Boot & Shoe.....291, 889 | |
| Tool.....1389 | Axial.....488-489 | Bristle.....921, 1271 | |
| Bench Cans992 | Centrifugal.....489 | Cup.....945 | |
| Bench Grinders917, 1270 | Portable.....359, 488, 1059-1060 | End.....940, 942, 944 | |
| Bench Scales1433, 1491-1495 | Boards, Directory1569 | Flap.....937 | |
| Bench Vises1293-1294 | Body Lotions749 | Fountain.....799 | |
| Benches | Bollards54, 85, 87, 865 | Maintenance.....26, 300-301, 1383, 1386 | |
| Locker Room.....108, 382 | Bolt Cutters1360-1361 | Paint.....1046 | |
| Packaging.....1433 | Bolt Holder Pliers1349 | Parts Cleaning.....993 | |
| Park.....380 | Bolt Removal Penetrants1013 | Pot.....26, 301 | |
| Service.....123-125 | Bolts | Scratch.....946-947, 1087 | |
| Shipping.....1433 | Carriage.....85, 89 | Scrub.....26, 291, 300, 946 | |
| Work.....103, 112-117, 120-123, 125, 1432 | Eye.....194 | Snow.....364 | |
| Benchstand Belts929 | Bonding & Grounding Wires252-253, 665 | Toilet Bowl.....349 | |
| Benzalkonium Towelettes729-735, 748 | Bookcases1567 | Tube.....945 | |
| Berms, Spill Control681, 711-712, 714 | Booms | Vehicle.....292 | |
| Bevels1280-1281 | Jib.....201 | Wheel.....941-944, 1271 | |
| Bibs | Spill Control.....679 | Whitewash.....292 | |
| Leather.....1132 | Booster Cables1542 | Window.....292 | |
| Welding.....1132 | Boot, Decontamination907 | Bubble Mailers1435 | |
| Bicycle Racks379 | Boot & Shoe Cleaners889 | Bubble Pouches1435 | |
| Bi-Metal Thermometers1473 | Boot Brushes291, 889 | Bubble Wrap1427 | |
| Bin Carts7-8 | Boot Covers289, 527, 534, 632, 889 | Buckets305-307 | |
| Bin Racks8-9, 11, 39, 121 | Boot Sanitizer907 | Buckles | |
| Bin Shelves6, 11, 15-17, 21, 59-60 | Boot Trays889 | Plastic.....1421-1422 | |
| Bin Support Panels7 | Boots | Poly.....1422 | |
| Binders1579 | Chemical Resistant.....631 | Stainless Steel.....1420 | |
| MSDS.....849 | Knee.....631-632 | Steel.....1421 | |
| SDS.....849 | Waders.....633 | Window.....1221 | |
| Bins | Winter.....635-636 | Buffers, Air1221 | |
| ESD.....25 | Work.....632-633 | Buffing Compounds937 | |
| Mobile.....6 | Borescope, Inspection Cameras1485 | Buffing Wheels937 | |
| Nesting.....18-19, 26 | Bottle Jacks206 | Bump Caps415, 417 | |
| Revolving.....29 | Bottles | Bump Guard, Forklift186 | |
| Shelf.....13-15, 25 | Dispenser.....672 | Bumpers, Dock213 | |
| Small Parts.....11, 25, 31, 39 | Storage.....28 | Bung Wrenches250 | |
| Stacking.....4-6, 13-14, 16-17, 21, 26, 40-41 | Box Sealing Tape1410-1411, 1413, 1429 | Bungee Cords1455, 1457 | |
| Stacking Container.....4 | Box Sealing Tape Dispensers1411, 1429 | Burn Care | |
| Steel.....40-41, 44-45 | Box Trucks166, 172-175 | Blankets.....753 | |
| Wire Mesh.....4 | Box Wrenches | Creams.....749 | |
| Bit Holders1343 | 15 Degree Offset.....1336 | Dressings.....732, 753 | |
| Bits | 25 Degree Offset.....1336 | Gels.....753 | |
| Auger.....1199 | 45 Degree Offset.....1336 | Kits.....753 | |
| Core.....1194 | Geared.....1331 | Ointments.....749 | |
| Cross-Point / Phillips®.....1345 | | Sheets.....753 | |



| | | | |
|---|---|--|---|
| Cabinet Carts660, 662 | Cabinet Drawers37 | Cabinet Tables124 | Cabinet Tip Screwdrivers1309-1312, 1338-1340, 1383 |
| Cabinets | Acid / Corrosives.....658, 664-666 | Computer.....1559-1560 | Drum.....663, 665 |
| Extinguisher.....653 | Filing.....1562-1563, 1565-1566 | First Aid.....739 | Flammables.....658, 660-662, 665, 667 |
| Gas Cylinder.....1077 | Key.....1570 | Paint and Ink.....658, 662-663 | Small Parts.....30-34, 37-38, 42-43, 45 |
| Storage.....9-10, 35, 94-103, 381, 1561, 1563 | Tool Storage.....103, 1309, 1312, 1395-1400 | Cable Connectors, Welding1084-1085 | Cable Cutters |
| Industrial Grade.....1085, 1349-1352, 1361 | Insulated.....1377 | Cable Lockouts779 | Cable Lugs, Welding1085 |
| Cable Protectors | Dock.....217 | Office.....218, 1540 | Welding.....1110 |
| Cable Tie Tools1452 | Cable Ties793-794, 1435, 1452 | Cable Tracers1468, 1543 | Cables |
| Aircraft.....194 | Booster.....1542 | Welding.....1085 | Caddies, Table1557 |
| Caddy, Waste Container266 | Cafeteria Supplies | Aluminum Foil.....1583 | Cling Wrap.....1583 |
| Coffee Equipment.....1583-1584 | Coolers.....1586 | Cup Dispensers.....1583 | Cups.....1583 |
| Forks.....1583 | Knives.....1583 | Microwave Ovens.....1584 | Napkin Dispensers.....343-344, 1583 |
| Napkins.....343-344, 1583 | Plates.....1583 | Refrigerators.....1584 | Spoons.....1583 |
| Stirring Sticks.....1583 | Straws.....1583 | Table Caddies.....1557 | Tables.....382, 1556-1557 |
| Calibration Gas Regulator484-486 | Calipers, Digital1275, 1309-1310 | Cam & Groove Fittings, Pumps263 | Cameras |
| Inspection.....1376, 1485 | Thermal.....1470 | Cans | Bench.....992 |
| Drip.....670 | Garbage.....169, 266-275, 349-350,383, 761, 1577 | Gas.....671-672 | Jerry.....671-672 |
| Oil.....999 | Oily Waste.....670-671 | Plunger.....670 | |

INDEX

| | | | | | | | |
|--|---|--|----------------------------------|---|---|---|-----------------------------------|
| Safety..... | 668-669 | Office..... | 1546, 1548-1549, 1553-1554 | Cleaners | | Liquid Repellent..... | 638, 1045 |
| Step..... | 269-270, 761 | Stacking..... | 1555 | Battery..... | 1015 | Rubber..... | 1012, 1015, 1045 |
| Cantilever Racks | 52 | Task..... | 1546, 1551 | Degreasers..... | 312-315, 319, 1002-1007, 1015, 1036, 1144 | Coating Thickness Gauges | 1478 |
| Cap Seal Crimpers | 250-251 | Chalk Lines | 1279 | Electrical..... | 319, 686, 1005-1007, 1015, 1037 | Coatings | |
| Cap Seals, Drum | 251 | Changing Tables | 348 | File..... | 1037 | Anti-Slip..... | 873, 1019 |
| Cape Chisels | 1368 | Channelizers, Traffic Control | 864 | Hand..... | 315, 324-329, 331-332 | Anti-Spatter..... | 1143, 1145, 1147 |
| Caps | | Chaps, Welding | 1132 | Heavy-Duty..... | 1037 | Belt Dressing..... | 1012 |
| Bump..... | 415, 417 | Chargers | | Industrial..... | 310-320, 349, 759-760, 889, 1003-1005, 1014-1015, 1020, 1037, 1043, 1144-1146 | Floor..... | 311, 362, 873, 1019, 1021 |
| Insulator..... | 1098 | Batteries..... | 1167, 1507, 1515 | Laundry Detergents..... | 317 | Galvanizing Compounds..... | 1014, 1144, 1146-1147 |
| Welding..... | 1125, 1133 | Cordless Drill..... | 1167 | Lens..... | 409, 465, 360 | Marking Wands..... | 1038-1040 |
| Caps & Plugs, Pipe Thread | 1240-1242 | Flashlight..... | 1515 | Welding Tip..... | 1073 | Paint..... | 1040 |
| Carabiners | 516, 520 | Checklist Kit, Forklift | 187 | Cleaning Equipment | | Rust Converters..... | 1014, 1146, 1148 |
| Carbon Monoxide Meters | 487 | Chemical Hazard Signs | 804, 808 | Broom & Mop Racks..... | 286 | Rust Preventers..... | 1014, 1146 |
| Carburetor Cleaner | 1015 | Chemical Resistant Boots | 631 | Brooms..... | 287-290, 301 | Striping Machines..... | 1039-1040 |
| Cargo Bars | 212, 1457 | Chemical Resistant Clothing | | Brushes..... | 26, 291-292, 300-301, 349, 946, 1383, 1386 | Wood Fillers..... | 1022 |
| Cargo Nets | 1455 | Aprons..... | 530-531, 533 | Buckets..... | 305-307 | Coats | |
| Carpenter Axes | 368 | Coveralls..... | 537-539 | Buckets / Wringers..... | 306-307 | Arc Flash..... | 556 |
| Carpenter Squares | 1280 | Chemical Resistant Gloves | 583-592 | Carts..... | 275, 309 | Flame Resistant..... | 556 |
| Carpenters' Glue | 1029 | Chest Protectors, Welding | 1125 | Dusters..... | 294, 302, 320 | Heat Resistant..... | 551 |
| Carpet Cleaners | 317 | Chest Waders | 633 | Dustpans..... | 290, 296, 687 | Winter..... | 552 |
| Carriage Bolts | 85, 89 | Chests, Tool Storage | 1309-1310, 1394-1399, 1402-1403 | Mops..... | 292-295, 304-306 | Coffee Equipment | 1583-1584 |
| Carton Rack | 1434 | Chippers, Air | 1088, 1207, 1213 | Pads..... | 292, 294, 302, 320, 362 | Coil Cleaner | 1309-1312, 1367-1368, 1370 |
| Carton Staplers | 1446-1447 | Chipping Hammers, Welding | 1087-1088 | Pressure Washers..... | 374-375 | Cold Chisels | 1309-1312, 1367-1368, 1370 |
| Cartridge Rolls | 929 | Chisel Holders | 1367 | Scrubbers..... | 292, 302, 320 | Cold Compresses | 731-732, 734, 750 |
| Cartridges, Respirator | 456, 460-464, 466, 470, 472-473, 475, 477, 480 | Chisels | | Squeegees..... | 296-299, 301, 687 | Cold Wire Feed Torches | 1091 |
| | | Cape..... | 1368 | Sweepers..... | 286, 358 | Cold Wire Feeders, TIG Torch | 1091 |
| | | Cold..... | 1309-1310, 1312, 1367-1368, 1370 | Trigger Sprayers..... | 302, 320 | Collapsible Containers | 44-45 |
| | | Hand..... | 1194, 1381 | Vacuum Cleaners..... | 352-361, 688, 1225 | Collet Bodies, TIG Torch | 1107-1109 |
| | | Scaling..... | 1088, 1194 | Water Brooms..... | 377 | Column Protectors | 86 |
| | | Woodworking..... | 1367 | Window Washers..... | 299 | Combination Saw Blades | 1203 |
| Carts | | Chucks | | Wringers..... | 294, 307 | Combination Slip-Joint Pliers | 1377 |
| Audio-Visual..... | 1560-1561 | Rail..... | 210 | Cleaning Fluids, Parts Washers | 995 | Combination Wrenches | 1331-1333 |
| Bin..... | 7-8 | Wheel..... | 210-211 | Cleats..... | 636, 872 | Sets..... | 1309-1310, 1312, 1332, 1334, 1337 |
| Cabinet..... | 660, 662 | Chop Saws | 914, 1174 | Clevis Grab Hooks | 192-193 | Combined Drills & Countersinks | 961 |
| Computer..... | 1561 | Chucking Reamers | | Cling Wrap | 1583 | Combo Kits | 1164-1166 |
| Drum..... | 701 | Cobalt..... | 985 | Clipboard | 1579 | Combustible Gas Detectors | 487 |
| Drywall..... | 159 | HSS..... | 981-985 | Clocks | | Communication | |
| Gas Cylinder..... | 1078 | Chucks | | Time..... | 1575 | Cell Phone Accessories..... | 443 |
| Hose Reel..... | 1237 | Air..... | 1224 | Wall..... | 1575 | Cell Phone Holders..... | 443, 1387, 1390 |
| Janitorial..... | 275, 309 | Drill..... | 1268-1269 | Clevis Grab Hooks | 192-193 | Horns..... | 221 |
| Ladder..... | 134 | ER Collet..... | 1269 | Cling Wrap | 1583 | Megaphones..... | 444 |
| Laundry..... | 303 | Circuit Breaker Extension Cords | 1538 | Clipboard | 1579 | Signal Horns..... | 444 |
| Lumber..... | 159-160 | Circuit Breaker Lockouts | 781-782 | Clips, Alligator | 1460, 1463 | Two-Way Radios..... | 435, 438-439, 441-442 |
| Order Picking..... | 165 | Circuit Testers | 1461, 1539 | Clocks | | Compound Leverage Wrenches | 1372 |
| Parts Storage..... | 42 | Circular Saw Blades | 914, 1202-1203 | Time..... | 1575 | Compounds | |
| Security..... | 77 | Circular Saws | | Wall..... | 1575 | Buffing..... | 937 |
| Shelf..... | 73, 76-77, 161-165, 167-168, 170 | Framing..... | 872 | Close Quarter Drills | 1184 | Retaining..... | 1027 |
| Shop..... | 7-8, 42, 73, 76-77, 161-170 | Heavy-Duty..... | 1162, 1177 | Closures, Drum | 234, 251 | Sweeping..... | 290 |
| Stock Picking..... | 165 | Circular Split Dies | 978, 980 | Clothes Hooks | 350 | Tapping..... | 1149 |
| Tool..... | 123-125, 1395, 1397, 1400 | Citrus Base Cleaners | 319, 1003, 1005, 1036 | Clothing | | Compresses | 729-732, 734-735, 743, 746, 750 |
| Trades..... | 169 | Clamp Meters | | Arc Flash..... | 554-557 | Compressors | |
| Utility..... | 76, 166, 168-170 | AC / DC..... | 1466 | Chemical Resistant..... | 530-531, 533, 537-539 | Air..... | 1262-1265 |
| Welding..... | 1078 | Current Clamps..... | 1461, 1466, 1468, 1540 | Cooling..... | 645-647 | Electric..... | 1262-1264 |
| Wire Spool..... | 167 | True RMS..... | 1460, 1466 | Flame Resistant..... | 538, 541-542, 548, 554-557 | Gas..... | 1263-1265 |
| Cases | | Clamps | | Flame Retardant..... | 542, 548 | Computer Cabinets | 1559-1560 |
| Blade Disposal..... | 1438 | Angle..... | 1285 | General Protection..... | 527, 529, 531-539, 689-693, 697 | Computer Carts | 1561 |
| Equipment..... | 1461, 1464-1465, 1471 | Bar..... | 1284-1287 | Hangers..... | 1581 | Computer Desks | 1560 |
| Eyewear..... | 407 | Beam..... | 199, 519 | Heat Resistant..... | 551 | Computer Supplies | |
| Small Parts..... | 36 | C-Clamps..... | 1288-1289 | High Visibility..... | 543, 545-549, 551 | Grounding Mats..... | 904 |
| Casters | 137, 152-154, 162-165, 171, 176-177, 227-231, 245-246, 1119, 1433, 1550 | Drum Lifting..... | 240, 243 | Limited Use..... | 527, 529-539, 689-693, 697 | Keyboard Trays..... | 1558 |
| | | Ear..... | 1238 | Rainwear..... | 540-543, 548, 551-552 | Keyboard Wrist Rests..... | 1558 |
| Caulk | 1025 | Edge-Gluing..... | 1288 | Suspenders..... | 1389 | Monitor Stands..... | 1577 |
| Caulking Guns | 1018, 1023-1024, 1035, 1045, 1161 | Ground - Welding..... | 1086 | Welding..... | 1125, 1132-1133 | Conditioners | |
| | | Hold-Down..... | 1290-1292 | Winter..... | 552, 555 | Air..... | 1500 |
| Caution Tags | 790 | Hose..... | 1238 | Work..... | 418, 420, 530-531, 550, 552-554, 1133 | Skin..... | 333 |
| C-Clamps | 1288-1289 | Latch..... | 1290-1292 | Clothing Kits, Arc Flash | 556-557 | Conductivity Meters | 1490 |
| Ceiling Fans | 1498 | L-Clamps..... | 1284 | Club Hammers | 369, 1365-1366 | Conductor Tubes, MIG Gun | 1096 |
| Ceiling Mounted Heaters | 1504 | Lifting..... | 198 | Coagulants | 742, 761 | Cone Bars | 863 |
| Cell Phone | | Paper..... | 1565 | Coat Racks | 1581 | Cones | |
| Accessories..... | 443 | Parallel..... | 1286-1287 | Coated Gloves | 562-574, 576-578, 580, 591-593, 627-628 | Crowd Control..... | 296, 308 |
| Holdings..... | 443, 1387, 1390 | Pipe..... | 1285 | Coating | | Pallet..... | 48, 1423 |
| Cements, Pipe | 1022 | Quick..... | 1288 | Acrylic..... | 1040, 1042-1044 | Safety..... | 308 |
| Center Punches | 1309-1310, 1312, 1368, 1370 | Spring..... | 1288 | Alkyd..... | 1040-1041, 1043-1044 | Traffic Control..... | 862-863 |
| Centrifugal Blowers | 489 | Straight Line..... | 1290, 1292 | Antislip..... | 1045 | Confined Space Lockouts | 784 |
| Ceramic Magnets | 1299 | Toggle..... | 1290-1291 | Epoxy..... | 1042-1043 | Confined Space Signs | 758, 804, 808 |
| CFC Free Degreasers | 319, 1002-1003, 1007 | Claw and Ripping Hammers | 1364 | Floor..... | 1019, 1044-1045 | Connectors | |
| Chain | | Claw Hammers | 1362, 1364 | High Heat..... | 1042-1043 | Anchorage..... | 516-517, 519 |
| Beaded..... | 794 | Clean Air Solvents | 1002 | Hydrophobic..... | 638, 1045 | Cable..... | 1084-1085 |
| Crowd Control..... | 794, 880 | Clean Room Matting | 907 | Latex..... | 1042 | Swivel..... | 1219, 1250 |
| Lifting..... | 193 | Cleaner, Carburetor | 1015 | | | Wire..... | 1543 |
| Chain Nose Pliers | 1348 | | | | | | |
| Chain Wrenches | 1372 | | | | | | |
| Chains, Key | 1570-1571 | | | | | | |
| Chair Caddies | 1554 | | | | | | |
| Chairs | | | | | | | |
| Ergonomic..... | 1547-1549, 1554 | | | | | | |
| Folding..... | 382, 1554 | | | | | | |

| | | | |
|---|---|--|--|
| Conspicuity Tape850 | Couplers, Quick1207, 1233, 1246, 1248-1250 | Cut-Off Wheels912-916 | Desks |
| Construction, Vapor Barriers1437 | Couplings, Pipe Thread1240-1241, 1243-1244 | Cutters | Computer.....1560 |
| Construction Adhesives1029 | Coveralls | Annular.....972, 1193 | Office.....1567 |
| Construction Tape1437 | Arc Flash.....554-556 | Bolt.....1360-1361 | Shop.....102, 126 |
| Contact Cement1029 | Chemical Resistant.....537-539 | Cable.....1085, 1349, 1351-1352, 1361, 1377 | Detergents, Laundry317 |
| Contact Cleaners1005-1007 | Flame Resistant.....538, 554-556 | Insulated.....1377 | Dettol™.....748 |
| Contact Tips, MIG Gun1094-1098 | General Protection.....532-539, 689-693, 697 | Iron Shear.....1361 | Developers |
| Container FDA Liners280 | Limited Use.....537-539 | Paper.....1427, 1432-1433 | Non-Aqueous.....1144 |
| Containers | Work.....550, 554 | Rebar.....1361 | Non-Chlorinated.....1020, 1144 |
| Bottles.....28 | Covers | Rotary.....1163 | Diagonal Cutters1309-1312, 1348, |
| Collapsible.....44-45 | Boot.....289, 527, 534, 632, 889 | Tubing.....1374 |1350, 1353, 1377, 1383 |
| Distribution.....18-20, 22-24, 1564 | Drum.....236, 670, 699 | Cutting Attachments, Welding1065 | Dial Scales1494 |
| ESD.....25 | Fire Extinguisher.....653 | Cutting Fluids | Diaphragm Pumps258 |
| Food Handling.....175 | Pail.....236 | for all Metals.....1148-1149 | Die Grinders |
| Jars.....28 | Shoe.....289, 527, 889 | for Aluminum.....1148 | Air.....1204, 1212, 1215, 1220, 1223 |
| Mobile Bins.....6 | Toilet Seat.....348 | for Steel.....1148 | Electric.....1172 |
| Nesting Bins.....18-19, 26 | Waste Containers.....266, 268, 271-272, 276-277 | Cutting Tips1065, 1070-1072 | Dielectric Greases1018 |
| Poly.....27, 234, 671 | CPR | Cutting Tools | Dielectric Hasp Lockouts780 |
| Recycling.....276-279, 1577 | Kits.....763 | Adjustable Reamers.....985 | Dies |
| Revolving Bins.....29 | Masks.....729-730, 762-763 | Annular Cutters.....972, 1193 | Circular Split.....978, 980 |
| Salt & Sand.....363, 689 | Shields.....729-735, 762 | Auger Bits.....1199 | Die Stocks.....977 |
| Shelf Bins.....13-15, 25 | Crack Check1012, 1020, 1144, 1148 | Burs.....990-991, 1215 | Hexagonal.....978-979 |
| Small Parts Bins.....11, 25, 31, 39 | Crane Scales203, 1496 | Chucking Reamers.....981-985 | Diesel Conditioner1015 |
| Spill Control.....709-710 | Cranes | Circular Saw Blades.....914, 1202-1203 | Diffusers, MIG Gun1095-1098 |
| Stacking Bins.....4-6, 13-14, 16-17, 21, 26, 40-41 | Floor.....200, 202 | Circular Split Dies.....978, 980 | Digital Thermometers1472-1473 |
| Steel Bins.....40-41, 44-45 | Gantry.....200 | Combination Saw Blades.....1203 | Dilution Dispenser313 |
| Tanks.....27 | Jib.....201 | Combined Drills & Countersinks.....961 | Dip Tanks992 |
| Transfer Boxes.....19 | Shop.....202, 208 | Core Bits.....1194 | Dipping Baskets992 |
| Control Valves1000 | Truck Mounted.....202 | Countersinks.....962 | Direction Signs811 |
| Convertible Pliers1353 | Crayons | Cut-Off Blades.....1203 | Directory Boards1569 |
| Convex Mirrors882 | Lumber.....1142, 1444 | Die Stocks.....977 | Disc Holder Pads922-925, 927, 935-936, 938 |
| Conveyors224-225 | Temperature.....1142, 1445 | Drill Bits.....948-955, 963-972, | Discharge Hoses263 |
| Cooking Thermometers1471, 1473 | Cream Dispensers331 |1193, 1196, 1198-1199 | Discs |
| Coolant Tanks1150 | Creams | End Mills.....986-989 | Bristle.....921 |
| Coolers | Burn Care.....749 | Forstner Bits.....1199-1200 | Flap.....918-919 |
| Containers.....1586 | Hand.....331, 333 | Hand Reamers.....981 | Grip-On.....926 |
| Water.....650 | Skin.....333 | Hand Taps.....956-960, 974-975, 977, 988 | Resin Fibre.....922-923, 925 |
| Cooling Clothing | Crimped Filament Wheels912-913 | Hexagonal Dies.....978-979 | Roloc™ / Power-Lock.....924-925, 935 |
| Hard Hat Liners.....646 | Crimpers | Hole Saws.....1193, 1197-1198 | Stick-On.....926-927 |
| Hats.....645 | Cap Seal.....250-251 | Machine Taps.....976 | Surface Conditioning.....934-936, 938 |
| Headbands.....645, 647 | HVAC.....1359 | Mitre Saw Blades.....1203 | Dish Detergents316 |
| Neck Shades.....647 | Crimping Die Pliers1349, 1377 | Pipe Taps.....960, 973 | Disinfectants313-314, 318, 759-760 |
| Towels.....645-646 | Cross Check Tamper Proof Indicator1342 | Points.....1194 | Dispenser Bottles672 |
| Vests.....646-647 | Cross-Arm Strap Anchors519, 560 | Prentice Drill Bits.....969-970 | Dispenser Dilution313 |
| Wraps.....645, 647 | Crosses, Pipe Thread1244 | Reciprocating Saw Blades.....1201 | Dispensers |
| Copper Hammers1365 | Crossover Ladders140 | Rotary Hammer Bits.....1195-1196 | Aisle Marking Tape.....868 |
| Cord Reels | Cross-Point Bits1345 | Screw Extractors.....960, 989 | Box Sealing Tape.....1411, 1429 |
| Extension Cords.....1531-1532, 1537 | Cross-Point Screwdrivers1309-1312, | Tap & Drill Sets.....973 | Cream.....331 |
| Fluorescent.....1532 |1338-1341, 1378, 1383, 1386 | Taper Pin Reamers.....982 | Cup.....1583 |
| Incandescent.....1531-1532 | Crowbars | Tool Holders.....986, 1269 | Dust Mask.....453 |
| Quad Box.....1531 | Non-Sparking.....1380 | Cutting Torches1065 | Ear Plug.....427, 431 |
| Single Outlet.....1531-1532 | Pitch Point.....368 | D Handle Drills1183-1184 | Filament Tape.....1411-1413 |
| Triple Outlet.....1532 | Crowd Control | Danger Tags790 | Gloves.....600 |
| Work Lights.....1531 | Base.....874 | D-Bolt Anchors516, 519 | Gummed Tape.....1411, 1413 |
| Cord Retainers, Eyewear408 | Chain.....794, 880 | Dead Blow Hammers1309-1312, 1362-1363 | Hand Sanitizer.....323-324 |
| Cord Sets, GFCl1539 | Cones.....296, 308 | Deburring Hand Tools1308 | Hand Soap.....315, 324-326, 330-333 |
| Cordless Power Tool Batteries1156-1164, 1167 | Rope & Posts.....821, 874-880 | Deburring Wheels936, 938, 1271 | Napkin.....343-344, 1583 |
| Cordless Screwdrivers1161, 1187 | Wall mounted.....875, 877 | Decking Beams212, 1457 | Paper Towel.....340-343, 1583 |
| Cords | Crutches, First Aid758 | Degreasers | Reel.....167 |
| Bungee.....1455, 1457 | CSA Standard Signs814-817 | CFC Free.....319, 1002-1003, 1007 | Sanitary Napkin.....348 |
| Extension.....1535-1538, 1541 | Cultivators368 | Engine.....1015 | Scotch™ Tape.....1580 |
| Core Bits1194 | Cup Brushes945 | Flash Free.....1007 | Strapping.....1420, 1422 |
| Coring Motors1189 | Cup Dispensers1583 | Food Grade.....1003-1004, 1007 | Stretch Wrap.....1424-1426 |
| Corkboards1569 | Cup Magnets1299 | Heavy-Duty.....312-315, 319, 1002-1005, 1036 | Toilet Paper.....345-347 |
| Corn Brooms289-290 | Cupmounts1272 | Multi-Purpose.....312, 319, 1002-1004 | Toilet Seat Cover.....348 |
| Corner Protectors48, 86-87, 216, 1421, 1423 | Cups | Non-Chlorinated.....1144 | Two-Way Tape.....1416 |
| Corrugated Boxes1431 | Cafeteria.....1583 | Solvent Free.....313, 1002-1003 | Wipes.....334, 336, 338-340 |
| Corrugated Pads1431 | Measuring.....317, 994 | Deheaders, Drum250 | Display Hangers, Merchandise1435 |
| Corrugated Paper1430 | Vacuum.....196-197 | De-Icer1015 | Displays, Literature1568 |
| Corvers, Pallet1423 | Curtain, Privacy Shower727 | Delineators, Traffic Control863-864 | Disposable Dust Masks447, 453 |
| Cotton Balls747 | Curtains, Strip91-93 | Demolition Hammers1187 | Disposable Face Mask447 |
| Cotton Tip Applicators729, 732, 747 | Curved Blade Knives1382, 1386 | Depressors, Tongue734, 747 | Disposable Gloves594-600, 656, 729-735, 762 |
| Cough and Cold Relievers752 | Curved Claw Hammers1309-1312, 1364, 1380 | Desiccant Systems1251, 1257 | Disposable Respirators447-453 |
| Counters | Cut & Polish Wheels938 | Desiccants1429 | Distribution Containers18-20, 22-24, 1564 |
| Measuring.....1484 | Cut Resistant Gloves575-581, 613 | Desk Lamps1524, 1582 | Dock Equipment |
| Ratchet.....1483 | Cut-Off Blades1203 | Desk Organizers1577 | Bumpers.....213 |
| Tally.....1483 | Cut-Off Tools, Air1204 | | Cable & Hose Protectors.....217 |
| Countersinks962 | | | Dock Risers.....215 |
| Countersinks & Drills, Combined961 | | | Dockboards.....215 |
| Counting Scales1491 | | | Dockplates.....215 |
| | | | Fenders.....212 |

-D-

INDEX

| | | | | | | | |
|-----------------------------------|-----------------------|--|-----------------------|--|----------------------------|--------------------------------------|--------------------------------------|
| Levelers..... | 214 | Hammer Drill / Driver..... | 1157-1159 | Dust Masks, Disposable | 447, 453 | Slot Drills..... | 986-987 |
| Lights..... | 218-220 | Hand Powered..... | 1182-1183, 1186 | Dust Mop Frames | 293-295, 302 | Square End..... | 988-989 |
| Pallet Pullers..... | 186 | Drills & Countersinks, Combined | 961 | Dust Mops | 293, 295 | Supermills..... | 987 |
| Rail Chocks..... | 210 | D-Ring Harnesses | 495 | Dusters | | Weldon Shank..... | 986-987 |
| Twin Ramps..... | 214 | Drinks, Rehydration | 648-649 | Aerosol..... | 319, 1006-1007 | End Wrenches | 1373 |
| Walkramps..... | 214 | Drip Cans | 670 | Janitorial..... | 294, 302, 320 | Engine Degreasers | 1015 |
| Wheel Chocks..... | 210-211 | Drip Pans | 252, 680-681 | Dustpans | 290, 296, 687 | Engine Stands | 208 |
| Dock Lights | | Drive Pin Punches | 1369 | Dye Penetrants | 1012, 1020, 1144, 1148 | Engine Tilters | 208 |
| Double Strut..... | 219 | Drop Sheets | 1054 | Drops, Eye | 728 | Engine-Powered Pumps | 264 |
| Flexible..... | 218-219 | Drum Equipment | | | | Engravers | |
| Halogen..... | 218 | Bonding & Grounding Wires..... | | | | Air..... | 1212, 1223 |
| Incandescent..... | 219 | | 252-253, 665 | | | Dremel..... | 1192 |
| Single Strut..... | 218-219 | Cabinets..... | 663, 665 | Ear Clamps | 1238 | Entrance Matting | |
| Stop & Go..... | 220 | Cap Seals..... | 251 | Ear Muffs | | Carpet..... | 886-887 |
| Docking Stations | 482-483, 485-486 | Carts..... | 701 | Cap Mounted..... | 433-439 | Eco..... | 886 |
| Document Laminators | 1574 | Closures..... | 234, 251 | Headband..... | 433-438, 549 | Needle Rib..... | 885 |
| Dollies | | Covers..... | 236, 670, 699 | Hygiene Kits..... | 435 | Pile..... | 885-888 |
| Aluminum..... | 177 | Deheaders..... | 250 | Neckband..... | 434, 436-437 | Polypropylene..... | 885 |
| Cabinet..... | 97, 103 | Dollies..... | 244, 266, 701-702 | Ear Plugs | | Rubber..... | 886-888, 901, 909 |
| Drum..... | 244, 266, 701-702 | Faucets..... | 251-252 | Corded..... | 423-426, 428-429 | Vinyl..... | 901 |
| Gas Cylinder..... | 1078 | Funnels..... | 241, 251, 699 | Dispensers..... | 427, 431 | Wiper..... | 874, 885-887 |
| Knee..... | 209 | Gauges..... | 251 | Disposable..... | 423-427 | Envelopes, Packing List | 1449 |
| Mechanic's..... | 209 | Heaters..... | 237 | Reusable..... | 426, 428-429 | Environmental Cleaners | 317-318 |
| Pail..... | 244 | Lids..... | 423-429 | Uncorded..... | 423-429 | Epoxies | |
| Polyethylene..... | 177 | Lifters..... | 238-243, 701 | Ear Protection Signs | 806, 809 | for Metal..... | 1020-1021 |
| Pry..... | 177 | Liners..... | 235 | Earloop Face Mask | 447 | General Purpose..... | 1023, 1033-1034 |
| Stacking..... | 20 | Mixers..... | 249 | Edge Protectors | 48, 86-87, 216, 1421, 1423 | Mixer Cups..... | 1021 |
| Steel Deck..... | 97, 103 | Pail Heaters..... | 237 | Edge-Gluing Clamps | 1288 | Putty..... | 1020-1021, 1023 |
| Waste Container..... | 266, 271, 276-277 | Pail Inserts..... | 235 | Ejectors, Smoke | 1501 | Syringe..... | 1021 |
| Wheel..... | 177, 208 | Pail Tipplers..... | 245 | Elastic Bandages | 731, 740, 746 | Two Part..... | 1033 |
| Wood..... | 176 | Pail Tumblers..... | 248 | Elbow Protectors | 643 | Epoxy Applicators | 1021, 1035 |
| Dome Mirrors | 881, 883 | Pails..... | 27, 695-696 | Elbows, Pipe Thread | 1240-1244 | Epoxy Coating | 1042-1043 |
| Doors, Curtain | 91-93 | Pallet Servers..... | 239 | Electrical Cleaners | | Epoxy Paint | 1042-1043 |
| Double Faced Hammers | 1366 | Pumps..... | 254-258 | Anti-Static..... | 1007 | Equalizers, Battery | 1037 |
| Double Sided Tape | 1416 | Racks..... | 245, 703 | Contact..... | 1005-1007 | Equipment Cases | 1461, 1464-1465, 1471 |
| Double Stepladders | 129-131 | Rockers..... | 245 | Dusters..... | 319, 1006-1007 | Equipment Stands | 170 |
| Drain Augers | 1375 | Rotators..... | 239, 248 | Electrical Gloves | 558-559 | ER Collet Chucks | 1269 |
| Drain Cleaners | 316 | Spill Pallets..... | 704-708, 710, 713-714 | Electrical Hazard Signs | 804-805, 808 | Ergonomic Products | |
| Drain Protectors | 682 | Spotters..... | 247 | Electrical Plug Lockouts | 781-782 | Back Supports..... | 641-642 |
| Drain Seals | 681-683, 689-693 | Stackers..... | 242 | Electrical Supplies | | Elbow Protectors..... | 643 |
| Drain Spades | 366 | Strainers..... | 235 | Alligator Clips..... | 1460, 1463 | Forearm Protectors..... | 643 |
| Drains, Air | 1257 | Tilters..... | 239-240, 254 | Batteries..... | 1507 | Gloves..... | 601-603, 605 |
| Drawers, Cabinet | 37 | Trays..... | 681, 703, 711, 713 | Battery Chargers..... | 1167, 1507, 1515 | Knee Pads..... | 639-640, 1133 |
| Dremel Tools | 1192 | Trucks..... | 246-247 | Booster Cables..... | 1542 | Kneeling Pads..... | 639 |
| Drench Hoses | 726 | Upenders..... | 250 | Cable Protectors..... | 218, 1540 | Seating..... | 1547-1549, 1554 |
| Dressings | | Valves..... | 252 | Connectors..... | 1219, 1250, 1543 | Tennis Elbow Braces..... | 643 |
| Burn Care..... | 732, 753 | Vents..... | 251 | Cord Reels..... | 1531-1532, 1537 | Wrist Supports..... | 643-644, 746 |
| Eye..... | 728, 734 | Drum Fans | 1497, 1502 | Extension Cords..... | 1535-1538, 1541 | Escape Ladders | 656 |
| Drift Punches | 1309-1310, 1369-1370 | Drum Tools | | GFCI Products..... | 1539-1542 | ESD Products, Bins | 25 |
| Drill Bits | | Cap Seal Crimpers..... | 250-251 | Outlet Boxes..... | 1539 | Exhaust Fans | 1501 |
| Aircraft Extension..... | 968, 972 | Pail Openers..... | 250 | Plugs..... | 1084 | Exit Lights | 1521 |
| Hex Shank..... | 1198 | Wrenches..... | 250 | Power Bars..... | 1541 | Exit Signs | 807, 810-811, 1521 |
| Jobber..... | 948-953, 963-967 | Drums | | Receptacles..... | 1084 | Expandable Gates | 309 |
| Masonry..... | 1196 | Fibre..... | 234 | Tape..... | 1417, 1544 | Extension Cords | |
| Silver & Deming..... | 954 | Polyethylene..... | 234, 691-695 | Circuit Breaker..... | 1538 | Circuit Breaker..... | 1538 |
| Spiral Flute..... | 972 | Steel..... | 234, 236 | Double Outlet..... | 1541 | Double Outlet..... | 1541 |
| Spline-Shank..... | 1196 | Dry Lubricants | | Single Outlet..... | 1535-1538, 1541 | Single Outlet..... | 1535-1538, 1541 |
| Straight Shank..... | 971 | Graphite..... | 1008 | Timers..... | 378 | Triple Outlet..... | 1535-1537 |
| Stub..... | 953-954 | Silicone..... | 1010 | Wire Strippers..... | 1351 | Extension Ladders | 132-133, 135 |
| Taper Length..... | 969 | Synthetic..... | 1009, 1012 | Electrical Switch Lockouts | 781 | Extension Poles | 287-288, 292-294, 297-299, 302, 1048 |
| Taper Shank..... | 955, 971 | Dryers | | Electrode / Rod Containers | 1089, 1134 | Extensions, Forklift | 187, 242 |
| Through-Hole..... | 1199 | Air..... | 1251, 1257 | Electrode Holders | 1084 | Extinguisher Cabinets | 653 |
| Two-Piece..... | 1193 | Hand..... | 351 | Electrode Ovens | 1089 | Extinguishers, Fire | 651-652 |
| Drill Press Vises | 1295-1296 | Drywall Carts | 159 | Electrodes | | Extractors | |
| Drill Presses | | Drywall Tools | | Gouging..... | 1087 | Fume..... | 1058-1060 |
| Bench..... | 1266-1267 | Hand Sanders..... | 1053 | Stick..... | 1136-1137, 1139 | Screw..... | 960, 989 |
| Electromagnetic..... | 1188-1189 | Hawks..... | 1053 | Tungsten..... | 1114 | Extraction Devices | 754-755 |
| Floor..... | 1266-1267 | Knives..... | 1052-1053, 1382, 1386 | Electromagnetic Drill Presses | 1188-1189 | Eye Baths | 728, 734 |
| Drilling Machines | | Putty Knives..... | 1052, 1382, 1386 | Emergency Blankets | 756 | Eye Bolts | 194 |
| Drill Presses..... | 1188-1189, 1266-1267 | Razor Blades..... | 1052 | Emergency Escape Respirators | 459 | Eye Dressings | 728, 734 |
| Gearhead..... | 1267 | Sanding Blocks..... | 1053 | Emergency Lights | 1521-1522 | Eye Drops | 728 |
| Drills | | Saws..... | 1053 | Emergency Showers | 718-719 | Eye Patches | 728, 730, 735 |
| Air..... | 1205, 1209, 1221-1223 | Scrapers..... | 1052, 1382 | Enclosures | | Eye Protection Signs | 806, 809 |
| Angle..... | 1184 | Spatulas..... | 1382 | Fences..... | 866 | Eyewash, Water Heater | 721 |
| Chucks..... | 1268-1269 | Trowels..... | 1053 | Steel Mesh..... | 90 | Eye Wash Stations | |
| Close Quarter..... | 1184 | T-Squares..... | 1280 | End Brushes | 940, 942, 944 | Bottled..... | 724-725 |
| D Handle / Spade Handle..... | 1183-1184 | Duct Tape | 1415 | End Cutters | 1349 | Faucet Mounted..... | 720 |
| Drill / Drivers..... | 1182 | Dump Trucks | 172-173 | End Mills | | Matting..... | 727, 893 |
| Drill / Drivers - Cordless..... | | Durometers | 1479 | Ball End..... | 988-989 | Pedestal Mounted..... | 717 |
| | 1156-1158, 1161, 1164 | Dust Collectors, Sandblasting | 1056 | Carbide..... | 988-989 | Self Contained..... | 722-723, 725 |
| Hammer..... | 1158-1159, 1184-1187 | Dust Mask Dispensers | 453 | HS-Co..... | 986-987 | Sink Mounted..... | 720 |



Solutions..... 722-725, 728, 734
 Supplemental..... 724-725
 Wall Mounted..... 716, 720
 Water Preservatives..... 722-723, 725

Eyewear
 Cases..... 407
 Cord Retainers..... 408
 Reading Glasses..... 399
 Safety Glasses..... 386-403, 407, 1310-1311
 Safety Goggles..... 404-406, 412, 689-697, 1120
 Welding Goggles..... 1120

-F-

Fabric Bandages..... 734, 740-742, 745
Fabric Shears..... 1357
Face Mask..... 447
Faceshields..... 410-413, 557
Facial Tissue..... 344

Fall Protection
 Anchorage Connectors... 516-517, 519, 560
 Carabiners..... 516, 520
 Davits..... 490-491
 Fall Protection Kits..... 505-507
 Harness..... 496, 500
 Harnesses..... 141, 494-502, 519, 560
 Kits..... 505-507
 Lanyards..... 141, 492, 507-515, 522-524, 560
 Life Lines..... 492, 512-515, 517-518, 520
 Rescue Hoist..... 492
 Rescue Systems..... 490-492, 496, 518
 Rope Grabs..... 517-518, 520
 Signs..... 806
 Winches..... 492

Fall Protection Kits..... 505-507
Fall Protection Lanyards, Hard Hat..... 420, 522, 524

Fan Forced Heaters..... 1503, 1505
Fan Guards..... 489

Fans
 Ceiling..... 1498
 Drum..... 1497, 1502
 Exhaust..... 1501
 Floor..... 1499
 Fume Extractor..... 1058
 Guards..... 489
 Office..... 1499
 Pedestal..... 1497-1499
 Wall Mounted..... 1497-1499

Fasteners
 Carriage Bolts..... 85, 89
 Eye Bolts..... 194
 Hex Nuts..... 85, 89
 Hook & Loop..... 1577
 Nails..... 1446
 Staples..... 1447
 Thread Repair..... 1307

Faucets
 Bathroom..... 350
 Drum..... 251-252

Fault Detectors, Welding..... 1012, 1020, 1144, 1148

FDA Liners..... 280

Feeders, Cold Wire..... 1091

Feeler Gauge Stock..... 1274

Fences
 Barrier..... 866
 Safety..... 865
 Snow..... 865

Fenders, Dock..... 212

Filament Tape..... 1412
Filament Tape Dispensers..... 1411-1413

File Cleaners..... 1307

File Folders..... 1564, 1579

File Handles..... 1307

Files
 Chain Saw Sharpening..... 1302
 Flat..... 1302-1305
 Half Round..... 1303
 Lathe..... 1303

Mill..... 1304
 Round..... 1302, 1304
 Sets..... 1306-1307
 Square..... 1304
 Thread Repair..... 1307
 Triangular..... 1304-1305
 Warding..... 1305

Filing Boxes..... 1564

Filing Cabinets
 Lateral..... 1562-1563, 1565
 Oversized Files..... 1566
 Vertical..... 1562-1563, 1565

Filing Trays..... 1577

Filler Metals..... 1136-1138, 1140

Fillet Gauges..... 1073

Filter Plate Lenses..... 1122, 1128

Filter Plates..... 1126, 1128

Filter/Regulator/Coalescing Filters..... 1257-1258, 1260

Filter/Regulator/Lubricators..... 1255, 1258-1259

Filter/Regulators..... 1255-1256, 1259

Filters
 ADF..... 1121, 1124-1126
 Air..... 359, 1058, 1251, 1255-1260, 1500, 1506
 Mechanical..... 1059
 Respirator..... 452, 456-461, 464, 475, 480
 Water..... 1585-1586

Finger Splints..... 754

Fingercots..... 600

Finishing Wheels..... 938

Fire Protection
 Blankets..... 656, 753
 Extinguisher Cabinets..... 653
 Extinguisher Covers..... 653
 Extinguishers..... 651-652
 Fire Alarm Protectors..... 654-655
 Signs..... 653, 807, 810, 812, 817, 822
 Smoke Alarm Testers..... 656
 Smoke Alarms..... 655

First Aid
 Airway Kits..... 763
 Ammonia Inhalants..... 734, 763
 Antiseptics..... 729-735, 745, 748-749, 759
 Bandages..... 729-735, 740-743, 745-747
 Blankets..... 729, 732, 756-757
 Burn Care..... 732, 749, 753
 Cabinets..... 739
 Coagulants..... 742, 761
 Compresses..... 731-732, 734, 750
 Cotton Products..... 729, 732, 747
 CPR Devices..... 729-735, 762-763
 Crutches..... 758
 Drench Hoses..... 726
 Dressings..... 728, 734
 Emergency Showers..... 718-719
 Extrication Devices..... 754-755
 Eye Care..... 728, 730, 734-735
 Eyewash Stations..... 716-717, 720-725, 728, 734
 Furnishings..... 757-758
 Instrument Tray..... 751
 Instruments..... 729-735, 747, 751, 756
 Kits..... 729-739, 745
 Leg Splints..... 754
 Lip Balm..... 335, 384, 750
 Literature..... 729-735
 Ointments..... 729-732, 745, 748-749
 Oxygen Mask..... 763
 Sharps Collectors..... 757, 760
 Signs..... 727, 805, 809, 812
 Stethoscopes..... 756
 Stretchers..... 754-755
 Tape..... 729, 744
 Thermometers..... 756
 Wheel Chair..... 758

First Aid Instruments, Sanitizing Solution..... 751

First Aid Room Furnishings..... 757-758

Fit Test Kits, Respirators..... 465

Fitters' Gloves..... 608-613, 618, 1310-1311

Fittings
 Air Hose..... 1234, 1239, 1247, 1250
 Cam & Groove..... 263
 Lubrication..... 999-1001
 Push to Connect..... 1239

Fixtures, Light..... 1520

Flagging Tape..... 869

Flags
 Marking..... 871
 Snow..... 871
 Traffic Control..... 858

Flagstaffs..... 856

Flame Resistant Clothing
 Coats..... 556
 Coveralls..... 538, 554-556
 Hoods..... 556-557
 Jackets..... 555
 Overalls..... 555-556
 Pants..... 554
 Rainwear..... 541-542, 548
 Shirts..... 554

Flame Retardant Clothing, Jackets..... 542, 548

Flange Sealants..... 1026

Flap Brushes..... 937

Flap Discs..... 918-919

Flap Wheels..... 919-920, 937

Flare Nut Wrenches..... 1335-1336

Flares, Traffic Control..... 859

Flaring Tools..... 1374

Flash Free Degreasers..... 1007

Flashback Arrestors..... 1074

Flashing Lights..... 222-223, 863, 866

Flashlights
 12 V..... 1162, 1513
 18 V..... 1162
 AA Cell..... 1511-1519
 AAA Cell..... 1509-1510, 1512, 1514, 1517
 Belt Holsters..... 1509-1511
 C Cell..... 1512-1513, 1516
 Coin..... 1514
 CR123 Cell..... 1511
 D Cell..... 1509-1510, 1517
 Hazardous Locations..... 1513
 Mini..... 1509, 1514, 1517, 1519
 N..... 1513
 Pocket..... 1512, 1515
 Rechargeable..... 1162, 1511, 1513, 1515-1516, 1518-1519
 Tactical..... 1512
 Waterproof..... 1513, 1517-1518

Flat Files..... 1302-1305

Flat Fold Respirator..... 447

Flat Mirrors..... 882

Flat Tip Screwdrivers..... 1309-1312, 1338-1341, 1378, 1383, 1386

Flat Top Dispensers..... 326, 330, 332-333

Flex Head Wrenches..... 1334-1335

Flex Torches..... 1103-1104

Flexible Netting..... 1430

Flint Lighters..... 1073

Flints..... 1073

Flip Charts, TDG..... 854

Flip-Top Mitts..... 604

Floodlights..... 1162, 1520, 1526-1528, 1530

Floor Cleaners..... 310-311, 317

Floor Coating..... 1019, 1044-1045

Floor Coatings..... 311, 362, 873, 1019, 1021

Floor Cranes..... 200, 202

Floor Fans..... 1499

Floor Finishes..... 311, 362

Floor Lamps..... 1527

Floor Lock Brakes..... 231

Floor Paint..... 1019, 1044-1045

Floor Repair..... 1018-1019, 1021, 1045

Floor Scales..... 1496

Floor Scrapers..... 292, 298

Floor Sealers..... 311, 362, 1019

Floor Signs..... 308, 813
 Safety..... 296, 308

Floor Stripper..... 311, 362

Flooring Knives..... 1441

Flowmeters, Welding..... 1068

Fluorescent Lamps / Light Bulbs..... 1524-1526, 1529-1530, 1582

Flux..... 1141, 1145

Foam, Packaging..... 1427

Foam Sealants..... 1023

Folders, File..... 1564, 1579

Folding Chairs..... 382, 1554

Folding Gates..... 82-83, 309, 867

Folding Stretchers..... 754

Folding Tables..... 121, 382, 1557

Food Grade Cleaners, Non-Flammable..... 1004

Food Grade Degreasers..... 1003-1004, 1007

Food Grade Lubricants..... 1008, 1010-1011, 1018

Food Handling Containers..... 175

Food Thermometer..... 1471, 1473

Foot, Splints..... 731, 734, 754

Foot Guards
 Aluminum..... 637
 Plastic..... 637
 Steel..... 637

Foot Warmers..... 636

Footrests..... 1549

Footwear
 Boot Trays..... 889
 Brushes..... 291, 889
 Chemical Resistant Boots..... 631
 Covers..... 289, 527, 534, 632, 889
 Foot Guards..... 637
 Foot Warmers..... 636
 Insoles..... 638
 Knee Boots..... 631-632
 Overboots..... 633
 Overshoes..... 633-634
 Toe Guards..... 637
 Waders..... 633
 Winter Boots..... 635-636
 Work Boots..... 632-633

Footwear Odour Neutralizers..... 750

Force Gauges..... 1484

Forceps..... 751

Forearm Protectors..... 643

Forklift Attachments
 Drum Lifters..... 238-239, 241-242
 Extensions..... 187, 242
 Maintenance Platforms..... 141

Forklift Bump Guard..... 186

Forklift Checklist Kit..... 187

Forklift PPE Battery Kit..... 186

Forks
 Cafeteria..... 1583
 Spading..... 367

Forstner Bits..... 1199-1200

Fountain Brushes..... 799

Fountain Rollers..... 799

Fountains, Water..... 1585-1586

Frames
 Crowd Control..... 880
 Dust Mop..... 293-295, 302

Framing Saws..... 872

Freeze Spray..... 1006

Friction Bolt Anchors..... 516

Full Face Respirators..... 455, 458-459, 462-463, 469

Fume Extractor Fans..... 1058

Fume Extractors..... 1058-1060

Fume Filters, Welding..... 1058-1059

Funnels
 Clean..... 994
 Drum..... 241, 251, 699
 Pail..... 699
 Polyethylene..... 317, 994
 Spill Control..... 699
 Steel..... 993

Furniture Pads..... 1454

Furniture Polish..... 319

Fuse Blocks, TIG Torch..... 1110

-G-

Galvanizing Compounds..... 1014, 1144, 1146-1147

Gantry Cranes.....200

Garage Jacks.....206

Garbage Bag Stands.....383

Garbage Bags.....278-282, 348-349, 383, 761

Garbage Cans.....169, 266-275, 349-350, 383, 761, 1577

Garden Hose Hangers.....378

Garden Hoses.....378

Garden Spades.....366

Gas Cans.....671-672

Gas Cylinder

- Brackets.....1079
- Cabinets.....1077
- Dollies.....1078
- Lockouts.....106
- Racks.....1079
- Stands.....1079
- Trucks.....1078
- Wrenches.....1073

Gas Detectors

- Air Quality.....487, 1474
- Calibration Gas.....484-486
- Carbon Monoxide.....487
- Combustible Gas.....487
- Multi-Gas.....482-486
- Sensor.....484-486
- Single-Gas.....482, 485

Gas Hoses, Welding.....1075, 1110

Gas Torches.....1064

Gasflux[®].....1145

Gasket Remover.....1015

Gaskets.....1025-1026

Gate Valve Lockouts.....784

Gate Valves.....252

Gates

- Expandable.....309
- Folding.....82-83, 309, 867
- Security.....82-84, 216, 866, 878

Gauge Protectors, Welding.....1067

Gauges

- Coating Thickness.....1478
- Drum.....251
- Force.....1484
- Pocket.....1275
- Pressure.....1068, 1224, 1232, 1489
- Thickness.....1478-1479
- Weld Fillet.....1073

Gauze Bandages.....729-735, 743

Gaylord Liners.....4, 280

Gear Wrenches, Sets.....1333-1334, 1337

Gearhead Machines, Drilling.....1267

Gels, Burn Care.....753

General Protection Clothing

- Aprons.....529, 534
- Coveralls.....532-539, 689-693, 697
- Hoods.....527, 534
- Lab Coats.....531-534, 536, 539
- Pants.....534
- Shirts.....534

GFCI

- Cord Sets.....1539
- Outlet Adaptors.....1540
- Outlet Boxes.....1539
- Plugs.....1540
- Power Strips.....1540-1542
- UPS Systems.....1542

GHS

- Information Centres.....848
- Information Charts.....847
- Safety Labels.....844-845
- Wallet Card.....844

Glass Cleaners.....315, 1004

Glasses

- Cases.....407
- Cord Retainers.....408
- Reading.....399
- Safety.....386-403, 407, 1310-1311

Gloves

- Aluminized.....624
- Anti-Vibration.....606-607
- Canvas Cotton.....612, 628
- Chemical Resistant.....583-592
- Coated.....562-580, 591-593, 627-628
- Cotton.....612
- Cut Resistant.....575-581, 613
- Dispensers.....600
- Disposable.....594-600, 656, 729-735, 762
- Dyneema[®].....577, 579, 581
- Electrical.....558-559
- Ergonomic.....601-603, 605
- Fingercots.....600
- Fitters'.....608-613, 618, 1310-1311
- Heat Resistant.....605, 622-624
- High Voltage.....558-559
- Holders.....593, 629
- Impact.....605-607, 644
- Inspection.....625
- Jersey.....628-629
- Kevlar[®].....575-576, 578-579, 581
- Knit.....626, 629
- Latex.....598-599
- Leather.....608-613, 618-621, 1129-1131, 1310-1311
- Natural Rubber.....569, 572
- Neoprene.....590
- Neoprene / Rubber.....589-590
- Nitrile.....563-574, 580, 583-586, 594-597, 656
- Nitrile/Polyurethane.....563-569, 571-574, 580
- Parade / Waiter's.....625
- Polyethylene.....600
- Polyurethane/Nitrile.....562-563, 574-580, 593
- Polyurethane.....562-563, 574-578, 580, 593
- PVC.....571, 591-592, 627-628
- Rubber.....570, 587-589
- Rubber Latex.....570, 586-589
- Sandblasting.....591
- Stainless Steel.....581
- Vinyl.....573, 597-598
- Welding.....619-621, 1129-1131
- Winter Lined.....604-605, 609-618, 626

Glow in the Dark Tape.....811, 870, 872-873

Glow Wands.....858, 860

Glue

- Carpenters'.....1029
- Sticks.....1036, 1418
- White.....1029
- Wood.....1029

Glue Guns.....1035-1036, 1418

Goggles

- Safety.....404-406, 412, 689-697, 1120
- Welding.....1120

Gouging Electrodes.....1087

Gouging Torches.....1087

Grab Bar.....350

Graffiti Removers.....319, 1005, 1043

Grain and Coal Scoops.....366

Grease Control Valves.....1000

Grease Guns.....996-997, 1017, 1161, 1309

Grease Pencils.....1142, 1445

Grease Pumps.....999-1000

Greases

- Bearing.....1017
- Dielectric.....1018
- High Temperature.....1017
- Multi-Purpose.....1011, 1018
- Synthetic.....1018
- White Lithium.....1018

Grinders

- Angle.....916, 1163, 1168-1171
- Angle - Air.....1204, 1211, 1215, 1222
- Bench.....917, 1270
- Die.....1172
- Die - Air.....1204, 1212, 1215, 1220, 1223
- Mini Die - Air.....1215
- Pencil - Air.....1223
- Tungsten Electrode.....1113-1114

Grinding Wheels

- Bench Mounted.....917, 1271
- Depressed Center.....912, 915-916
- Type 27.....912, 915-916
- Zirconium.....913-915

Grip-On Discs.....926

Ground Clamps, Welding.....1086

Grounding Mats.....904

Grounds, Welding.....1086

Grounds Maintenance

- Broadcast Spreaders.....364, 370
- Cultivators.....368
- Forks.....367
- Garden Hose Hangers.....378
- Garden Hoses.....376-378
- Hedge Shears.....369
- Hoes.....368
- Ice Salt.....364
- Lopping Shears.....369
- Picks.....368, 1381
- Rakes.....367
- Shovels.....364-366, 368, 1381
- Sidewalk Scrapers.....368
- Spades.....366
- Sprayers.....320, 371-373
- Sprinklers.....376
- Tree Pruners.....369
- Tree Trimmers.....369
- Turf Edgers.....368
- Wheelbarrows.....172, 370

Guard Rails.....54, 84-85, 489

Guards

- Foot.....637
- Perimeter.....51, 84-85, 88
- Shin.....638
- Toe.....637

Guides, Welding.....1117

Gummed Tape.....1413

Gummed Tape Dispensers.....1411, 1413

Guns

- Air.....1035, 1051, 1225-1230
- Caulking.....1018, 1023-1024, 1035, 1045, 1161
- Garden Hose.....376-377
- Glue.....1035-1036, 1418
- Grease.....996-997, 1017, 1161, 1309
- Heat.....1190-1191
- MIG.....1094-1096
- Nail.....1163, 1446
- Paint.....1051
- Sandblasting.....1057, 1225
- Screw.....1187
- Soldering.....1080-1082

-H-

H.I.D. Lamps / Light Bulbs.....1529-1530

Hacksaws

- Blades.....1300
- Frames.....1300-1301, 1309-1312

Hair Nets.....526-527

Half Mask Respirators.....454-455, 458, 461-464, 469

Half Round Files.....1303

Half Round Rasps.....1305

Halogen Lamps / Light Bulbs

-219, 1524, 1527-1528, 1582

Hammer Bits.....1195-1196

Hammer Drill / Drivers.....1157-1159

Hammer Drills.....1158-1159, 1184-1187

Hammer Tackers.....1446

Hammers

- Air.....1213
- Anti-Vibration.....1364-1365
- Ball Pein.....1309-1312, 1362, 1365, 1380
- Blacksmiths'.....1366
- Brass.....1365
- Brick.....1364
- Chipping.....1087-1088
- Claw.....1309-1312, 1362, 1364, 1380
- Club.....369, 1365-1366

- Copper.....1365
- Dead Blow.....1309-1312, 1362-1363
- Demolition.....1187
- Double Faced.....1366
- Mallets.....1309, 1311, 1362-1363, 1380
- Non-Sparking.....1380, 1386
- Rotary.....1159, 1185-1187
- Scaling.....1364
- Sledge.....369, 1365-1366, 1380
- Soft Face.....1363

Hampers.....303

Hand Chisels.....1194, 1381

Hand Cleaners

- Cream.....331
- Foam.....325, 329, 332
- Gel.....315, 326, 328
- Liquid.....315, 326, 331
- Lotion.....315, 324, 326-329, 332

Hand Creams.....331, 333

Hand Crimpers, HVAC.....1359

Hand Dryers.....351

Hand Lamps.....1525-1528, 1531-1532

Hand Pad Holders.....933-934, 938

Hand Pads.....621, 1131

Hand Powered Drills.....1182-1183, 1186

Hand Pumps.....254-256, 258-259

Hand Reamers.....981

Hand Rollers.....799

Hand Sanitizer Dispensers.....323-324

Hand Sanitizers.....323-324, 333, 760

Hand Scrapers, Non-Sparking.....1382, 1386

Hand Scrubbers.....292, 302, 320

Hand Seamers, HVAC.....1359

Hand Shields, Welding.....1123

Hand Stamps.....795-796, 1117

Hand Taps.....956-960, 974-975, 977, 988

Hand Tools

- Arbor Presses.....208
- Auto Body Repair.....208
- Axes.....368
- Bolt Cutters.....1360-1361
- Cable Cutters.....1085, 1349, 1351-1352, 1361, 1377
- Chisels.....1088, 1194, 1309-1312, 1367-1370, 1381
- Clamps.....1238, 1284-1292
- Crowbars.....368, 1380
- Deburring.....1308
- Drywall Tools.....1052-1053, 1280, 1382, 1386
- Hammers.....369, 1309-1312, 1362-1366, 1380, 1386
- Hex Keys.....81, 1309-1312, 1346-1347, 1383
- Hooks & Picks.....1307
- Insulated Cutters.....1377
- Iron Shear Cutters.....1361
- Knives.....1355, 1371, 1382, 1386, 1440-1442
- Levels.....1115-1117, 1279, 1281-1283, 1461
- Locking Pliers.....1352
- Magnets.....286, 1086, 1297-1299
- Mallets.....1309, 1311, 1362-1363, 1380
- Multi-Purpose.....1355
- Nippers.....282, 383, 1357
- Non-Sparking.....1380-1383, 1385-1386
- Nut Drivers.....1342, 1378
- Paper Cutters.....1427, 1432-1433
- Pinch Bars.....1367, 1380
- Pipe Tools.....1115-1117, 1309, 1372-1374, 1378
- Pliers.....364, 1288, 1309-1312, 1348-1354, 1377, 1383, 1386
- Pry Bars.....1309-1312, 1340, 1366-1367, 1380, 1386
- Pullers.....1309-1310, 1312, 1368-1370
- Punches.....1315-1322, 1324
- Rebar Cutters.....1361
- Rolling Head Bars.....1367
- Rotary Cutters.....1163
- Saws.....1300-1301, 1309-1312
- Scissors.....1356-1357, 1442, 1580
- Scrapers.....292, 298, 1382, 1386
- Screwdriver Bits.....1340, 1343-1345

| | | | | | | | |
|---|---|--|--------------------------|--------------------------------------|--|---|----------------------------------|
| Screwdrivers..... | 1309-1312, 1338-1341, 1378, 1383, 1386 | Hex Keys | 81, 1309-1312, 1346-1347 | HVAC | | Impact Sockets | 1323-1327 |
| Sealing Spatula..... | 1052 | Non-Sparking..... | 1383 | Air Conditioners..... | 1500 | Impact Wrenches | |
| Shears..... | 1356-1357 | Hex Nuts | 85, 89 | Air Filters..... | 359, 1058, 1500, 1506 | Air..... | 1205, 1208, 1210, 1214, 1222 |
| Snips..... | 1357-1359 | Hex Square Drive Bits | 1340, 1343 | Air Purifiers..... | 1500 | Cordless..... | 1159-1160 |
| Socket Sets..... | 1309-1315, 1325-1326 | Hex Wrenches | 1372, 1378 | Axial Blowers..... | 488-489 | Electric..... | 1181 |
| Sockets..... | 1309-1310, 1312-1327, 1385 | Hexagonal Dies | 978-979 | Ceiling Fans..... | 1498 | Incandescent Lamps / Light Bulbs | 1525-1526, 1528, 1532, 1582 |
| Squares..... | 1280-1281 | High Heat Coating | 1042-1043 | Ceiling Mounted Heaters..... | 1504 | Indigestion Relievers | 752 |
| Technicians'..... | 1309-1312, 1378-1379 | High Heat Paint | 1042-1043 | Centrifugal Blowers..... | 489 | Indoor / Outdoor Thermometers | 1472 |
| Tubing Cutters..... | 1374 | High Temperature Greases | 1017 | Drum Fans..... | 1497, 1502 | Industrial Cleaners | |
| Vises..... | 1293-1296 | High Visibility Clothing | | Exhaust Fans..... | 1501 | Aluminum..... | 1145 |
| Wedge..... | 1381 | Hat/Toque..... | 549 | Fan Forced Heaters..... | 1503, 1505 | Bleach..... | 314 |
| Wrecking Bars..... | 1366 | Jackets..... | 547-548 | Fan Guards..... | 489 | Boot and Shoe..... | 889 |
| Wrenches..... | 960, 977, 1309-1312, 1330-1337, 1384-1386 | Overalls..... | 543 | Floor Fans..... | 1499 | Brake..... | 1005, 1015 |
| Hand Towels | 334, 340-344, 384, 1005, 1583 | Pants..... | 548, 551 | Fume Extractors..... | 1058-1060 | Carpet..... | 317 |
| Hand Truck Step Ladder | 1581 | Parkas..... | 547 | Fume Filters..... | 1058-1059 | Coil Cleaner..... | 1005 |
| Hand Trucks | 144-146, 148-151, 1454, 1554 | Rain Jackets..... | 543 | Hand Crimpers..... | 1359 | Dish Detergents..... | 316 |
| Hand Warmers | 629 | Rain Suits..... | 543 | Hand Seamers..... | 1359 | Disinfectants..... | 313-314, 318, 759-760 |
| Hand Winches | 195 | Sweatshirts..... | 547 | Humidifiers..... | 1500 | Drain..... | 316 |
| Handles | | T-Shirts..... | 547 | Mechanical Filters..... | 1059 | Floor..... | 310-311, 317 |
| File..... | 1307 | Vests..... | 545-547 | Office Fans..... | 1499 | Food Grade..... | 1004 |
| Torch..... | 1065 | High Voltage Gloves | 558-559 | Pedestal Fans..... | 1497-1499 | Furniture Polish..... | 319 |
| Handling Labels | 1430, 1448 | Hi-Liters | 1578 | Portable Blowers..... | 359, 488, 1059-1060 | Glass..... | 315, 1004 |
| Hangers | | Hinges, Weld-On | 1088 | Portable Heaters..... | 1504 | Graffiti Removers..... | 319, 1005, 1043 |
| Clothes..... | 1581 | Hip Waders | 633 | Radiant Heaters..... | 1503-1505 | Heavy-Duty..... | 1037 |
| Garden Hose..... | 378 | Hoes | 368 | Radiator Heaters..... | 1503 | Machine..... | 320 |
| Merchandise Display..... | 1435 | Hoist, Rescue | 492 | Smoke Ejectors..... | 1501 | Multi-Purpose..... | 312-316, 319, 1003-1004, 1037 |
| Hanging Scales | 203, 1493-1494, 1496 | Hoists | | Tent Heaters..... | 489 | Non-Chlorinated..... | 1020, 1144 |
| Hard Hat Lanyards | 420, 522, 524 | Air..... | 191 | Wall Heaters..... | 1504 | Oven..... | 316 |
| Hard Hat Liners, Cooling | 646 | Electric..... | 191 | Wall Mounted Fans..... | 1497-1499 | Rust Removers..... | 1014, 1146 |
| Hard Hats | 414-418 | Manual..... | 190-191, 199 | Hydration Backpack | 647 | Scouring Powder..... | 316 |
| Hardness Testers | | Hold-Down Clamps | 1290-1292 | Hydrogen Peroxide | 734, 748, 759 | Stainless Steel..... | 316, 319, 1004 |
| Non-Metals..... | 1479 | Holders | | Hydrophobic Coating | 638, 1045 | Toilet Bowl..... | 314 |
| Steel & Alloys..... | 1479 | Cell Phone..... | 443, 1387, 1390 | Hygienic Products | | Urinal..... | 349 |
| Hardware | | Chisel..... | 1367 | Basins..... | 731, 734, 751, 758 | Industrial Jacks | 207 |
| Shims..... | 1273-1274 | Electrode..... | 1084 | Sanitary Napkins..... | 348-349 | Inflator Gauges, Tire | 1224 |
| Stock..... | 1274 | Gloves..... | 593, 629 | Shampoo..... | 325, 329 | Information Centers, MSDS | 848-849 |
| Harnesses | | Hand Pad..... | 933-934, 938 | Tampons..... | 348 | Information Centres | |
| Arc Rated..... | 500, 560 | TDG..... | 851 | Hygrometers, Thermo | 1474, 1476 | GHS..... | 848 |
| D-Ring..... | 495 | Tool..... | 986 | | | SDS..... | 848-849 |
| General..... | 141, 494-499, 501-502, 519 | Tool Storage..... | 1387-1388, 1392 | I-Beam Frame Levels | 1281 | Information Charts | |
| Traffic Control..... | 548 | Hole Saw Arbors | 1193, 1198 | Ibuprofen | 752 | GHS..... | 847 |
| Welding..... | 496, 500 | Hole Saws | 1197-1198 | Ice Cleats | 636 | WHMIS..... | 847 |
| Hasp Lockouts | 764, 768-769, 780 | Hoop, Respirators | 473, 479, 1127 | Ice Salt | 364 | Infrared Thermometers | 1469-1470 |
| Hats | | Hoods | | Ice Spikes | 636 | Inhalants, Ammonia | 734, 763 |
| Cooling..... | 645 | Arc Flash..... | 556-557 | Identification | | Ink, Stencil | 799 |
| Hard..... | 414-418 | Flame Resistant..... | 556-557 | Fountain Brushes..... | 799 | Ink Stencils | 797 |
| Hawks | 1053 | General Protection..... | 527, 534 | Fountain Rollers..... | 799 | In-Line Drills, Air | 1209, 1221 |
| Hazardous Materials Cabinets | 658, 660-667 | Rain..... | 541-543, 548 | GHS Products..... | 844, 847 | In-Line Filters | 1251, 1256 |
| Hazardous Materials Signs | 808 | Hook & Loop Fasteners | 1577 | Grease Pencils..... | 1142, 1445 | In-Line Lubricators | 1251, 1256, 1261 |
| Head Assemblies, MIG Gun | 1095 | Hooks | | Hand Rollers..... | 799 | In-Line Regulators | 1232, 1256, 1261 |
| Headbands, Cooling | 645, 647 | Clevis Grab..... | 192-193 | Hand Stamps..... | 795-796, 1117 | Insect Repellent | 335, 384 |
| Headgear, Respirators | 473, 479, 1127 | Clothes..... | 350 | Label Holders..... | 5, 12, 48, 72-73, 1571 | Insect Sting Relief | 749 |
| Headlights, Hard Hat | 419, 549 | Drum Lifting..... | 243 | Label Makers..... | 5, 12, 824-830, 1572-1574 | Inserts, Pail | 235 |
| Headsets | 435, 438-439 | Lifting..... | 192-193 | Labels..... | 818-819, 844-845 | Insoles | 638 |
| Hearing Bands | 430-431 | Sky..... | 199 | Lumber Crayons..... | 1142, 1444 | Inspection Cameras | 1376, 1485 |
| Heat Guns | 1190-1191 | Slip..... | 192-193 | Marking Flags..... | 871 | Borescope..... | 1485 |
| Heat Resistant Clothing | | Hooks & Picks | 1307 | Metal Markers..... | 1444 | Inspection Gloves | 625 |
| Aprons..... | 551 | Hoppers, Self-Dumping | 171 | MSDS Products..... | 667, 848-849 | Inspection Mirrors | 883 |
| Coats..... | 551 | Horizontal Sheet Rack | 53 | Paint Markers..... | 1142, 1442-1444 | Instant Adhesives | 1031-1032 |
| Leggings..... | 551 | Horns | 221 | Paint Sticks..... | 1142, 1443-1444 | Instrument Tray | 751 |
| Heat Resistant Gloves | 605, 622-624 | Signal..... | 444 | Pipe Markers..... | 833-841 | Instruments | |
| Heat Resistant Mitts | 622 | Hose Clamps | 1238 | Safety Whips..... | 856 | Anemometers..... | 1486-1487 |
| Heat Stress Meter | 645, 1475 | Hose Fittings | 1234, 1239, 1247, 1250 | SDS Products..... | 847-849 | Balometers..... | 1488 |
| Heaters | | Welding..... | 1074 | Self-Adhesive Letters..... | 800 | Bi-Metal Thermometers..... | 1473 |
| Ceiling Mounted..... | 1504 | Hose Protectors, Dock | 217 | Self-Adhesive Numbers..... | 800 | Borescope..... | 1485 |
| Drum..... | 237 | Hose Reel Carts | 1237 | Signs..... | 12, 48, 210, 308, 653, 727, 758, 803-817, 820-823, 849, 851, 857-859 | Cable Tracers..... | 1468, 1543 |
| Fan Forced..... | 1503, 1505 | Hose Reels | 1076, 1234-1237, 1532 | Snow Flags..... | 871 | Calipers..... | 1275, 1309-1310 |
| Pail..... | 237 | Hose Repair Kits | 377 | Soapstone..... | 1143 | Circuit Testers..... | 1461, 1539 |
| Portable..... | 1504 | Welding..... | 1075 | Stencil Inks..... | 799 | Clamp Meters..... | 1460-1461, 1466, 1468, 1540 |
| Radiant..... | 1503-1505 | Hose Whips | 1250 | Stencils..... | 797-798 | Conductivity Meters..... | 1490 |
| Radiator..... | 1503 | Hoses | | Tags..... | 12, 786-788, 790-793, 1448 | Cooking Thermometers..... | 1471, 1473 |
| Tent..... | 489 | Air..... | 1207, 1233-1235 | Tape..... | 811, 868-870 | Counters..... | 1483 |
| Wall..... | 1504 | Discharge..... | 263 | TDG Products..... | 851-854 | Digital Thermometers..... | 1472-1473 |
| Heating Tips | 1072 | Drench..... | 726 | WHMIS Products..... | 845-847 | Distance Measurers..... | 1276-1279, 1309-1312, 1482, 1484 |
| Hedge Shears | 369 | Garden..... | 378 | Windsocks..... | 871 | Feeler Gauge Stock..... | 1274 |
| Helmets, Welding | 481, 1121-1127 | Loc-Line®..... | 1150-1153 | Illuminometers, Digital | 1481 | First Aid..... | 729-735, 747, 751, 756 |
| Hex Bit Sockets | 1315-1316 | Lubricant..... | 996 | Impact Gloves | 605-607, 644 | Force Gauges..... | 1484 |
| Hex Bits | 1344 | Welding..... | 1068, 1075, 1110 | Impact Labels | 1430 | Gas Detectors..... | 482-487, 1474 |
| | | Hot Compresses | 731-732, 734, 750 | | | Hardness Testers..... | 1479 |
| | | Humidifiers | 1500 | | | | |
| | | Humidity Labels | 1429 | | | | |
| | | Humidity Meters, Infrared | 1475 | | | | |



Clevis Grab Hooks.....192-193
 Cranes.....200-202, 208
 Engine Tilters.....208
 Hoists.....190-191, 199
 Hooks.....192-193
 Jacks.....206-208, 212
 Jibs.....201
 Lift Tables.....178-179
 Lifting Clamps.....198
 Magnetic Lifters.....196, 198, 1298
 Manhole Lid Lifters.....489
 Pallet Lifters.....181, 184, 201
 Pallet Trucks.....144, 182-186
 Skid Lifts.....181, 184
 Sky Hooks.....199
 Slings.....188-189
 Slip Hooks.....192-193
 Stackers.....180, 703
 Vacuum Cups.....196-197

Light Bulbs
 Fluorescent.....1524-1526, 1529-1530, 1582
 H.I.D.....1529-1530
 Halogen.....219, 1524, 1527-1528, 1582
 Incandescent.....1525-1526, 1528, 1532, 1582
 LED.....219

Light Fixtures.....1520
Light Meters, Digital.....1481
Lighters, Flint.....1073

Lighting
 Bay Lights.....1520
 Desk Lamps.....1524, 1582
 Dock Lights.....218-220
 Emergency Lights.....1521-1522
 Exit Lights.....1521
 Flashing Lights.....222-223, 863, 866
 Flashlight Belt Holsters.....1509-1511
 Flashlights.....1162, 1509-1519
 Floodlights.....1162, 1520, 1526-1528, 1530
 Floor Lamps.....1527
 Hand Lamps.....1525-1528, 1531-1532
 Headlights.....419, 549
 Lamps / Light Bulbs.....219, 1524-1530, 1532, 1582
 Lanterns.....1516-1518
 Lightsticks.....858, 860
 Penlights.....1512
 Spot Lights.....187, 1516, 1518
 String Lights.....1528
 Task Lights.....1523, 1529-1530
 Telescopic Lights.....1528
 Traffic Wands.....1509
 Warning Lights.....222-223, 863, 866

Lighting Baton.....858, 860
Lightsticks.....858, 860

Limited Use Clothing
 Aprons.....529-531, 533-534
 Coveralls.....532-533, 535-539, 689-693, 697
 Hoods.....527, 534
 Lab Coats.....531-534, 536, 539
 Pants.....534
 Shirts.....534

Line Stripping Paint.....1039
Lineman's Pliers.....1309-1312, 1348
Linen Trucks.....303

Liners
 Container.....280
 Drum.....235
 Gaylord.....4, 280
 Hard Hat.....418, 553
 MIG Gun.....1095-1097
 Waste Container.....267, 269-270, 273, 285

Linoleum Knives.....1382, 1441
Lip Balm.....335, 384, 750
Liquid Measures.....993
Liquid Tip Markers.....846, 1445, 1578
Literature, First Aid.....729-735
Literature Displays.....1568
Litter Pickers.....282, 383
Litter Scoops.....282, 290, 383
Load Binders.....192
Lock Labels.....770
Locker Room Benches.....108, 382

Lockers
 Plastic.....109-110
 Steel.....104-108

Locking Pliers.....1288, 1309-1312, 1351-1354

Lockouts
 Ball Valve.....780, 782-784
 Butterfly Valve.....783
 Cable.....779
 Circuit Breaker.....781-782
 Confined Space.....784
 Electrical Plug.....781-782
 Electrical Switch.....781
 Gas Cylinder.....106
 Gate Valve.....784
 Hasps.....764, 768-769, 780
 Kits.....772, 777-779
 Pneumatic Fitting.....1250
 Pump.....259
 Stations.....772-779
 Tags.....786-790

Lockouts Dielectric, Hasps.....780

Locks
 Dielectric Padlocks.....769
 Padlocks.....99, 110, 764-772
 Wheel.....782

Loc-Line® Hosing.....1150-1153

Logistic Straps.....246, 1456

Logistic Tracks.....212, 1457

Long Nose Pliers.....1309-1312, 1348, 1351, 1377

Loosefill.....1428

Lopping Shears.....369

Lotions, Body.....749

Loudspeakers.....444

Lubricants
 Air Tool Oil.....1037, 1261
 Anti-Seize.....1016
 Bearing Greases.....1017
 Cutting Fluids.....1148-1149
 Dielectric Greases.....1018
 Dry.....1008-1010, 1012
 Food Grade.....1008, 1010-1011, 1018
 Freeze Spray.....1006
 General Purpose.....1013
 Graphite.....1008
 High Temperature Greases.....1017
 Layout Fluids.....1145, 1148
 Machinery Oil.....1011
 Mold Release.....1009
 Multi-Purpose Greases.....1011, 1018
 Penetrants.....1004, 1012-1013, 1020, 1144
 Pump.....1144
 Silicone.....1008, 1010
 Spray.....1008-1013, 1018
 Synthetic.....1009, 1012
 Synthetic Greases.....1018
 Tapping Compounds.....1149
 White Lithium.....1018
 White Lithium Greases.....1018
 Wire Pulling.....1012, 1543

Lubricating Equipment
 Control Valves.....1000
 Fittings.....999-1001
 Grease Guns.....996-997, 1017, 1161, 1309
 Grease Pumps.....999-1000
 Hoses.....996
 Loc-Line Hosing.....1150-1153
 Oil Cans.....999

Lubricators, In-Line.....1251, 1256, 1261

Lugs, Welding Cable.....1085

Lumber Carts.....159-160
Lumber Crayons.....1142, 1444



Machine Cleaners, Heavy-Duty.....320
Machine Stands.....120
Machine Taps.....976
Machine Tool Pumps.....1150
Machine Vises.....1295
Machine Wrap.....1426

Machinery
 Bandsaws.....1178
 Drilling Machines.....1188-1189, 1266-1267
 Rollers.....204-205
 Sandblasting Equipment.....1055-1057, 1225
 Shrink Wrap.....1426

Machinery & Operations Signs.....804-805, 809

Machinery Oil.....1011
Machinery Rollers.....204-205
Magnetic Brooms.....290
Magnetic Lifters.....196, 198, 1298
Magnetic Retrievers.....1297-1298
Magnetic Tags.....12

Magnets
 Bar.....1298
 Ceramic.....1299
 Cup.....1299
 Print Holders.....1298
 Rare Earth.....1299
 Retrievers.....1297-1298
 Strip.....1298
 Sweeper.....286
 Welding Grounds.....1086
 Welding Squares.....1086

Magnifier Plates.....1126, 1128

Magnifiers
 Illuminated.....1524
 Lenses.....1524

Mail Sorters.....1566
Mailboxes.....1576
Mailers.....1434-1435
Maintenance Brushes.....26, 300-301, 1383, 1386
Maintenance Platforms.....141
Maintenance Signs.....808-809, 813
Mallets.....1309, 1311, 1362-1363, 1380
Manhole Lid Lifters.....489
Manhole Shields.....489, 491
Manifolds, Air.....1250
Manometers.....1487-1488
Marine Jacks.....207

Markers
 Liquid Tip.....846, 1445, 1578
 Lumber Crayons.....1142, 1444
 Metal.....1444
 Office.....823, 846, 1442, 1445, 1569, 1578
 Paint.....1142, 1442-1444
 Paint Sticks.....1142, 1443-1444
 Permanent.....1442, 1445, 1578
 Pipe.....833-841
 Pipe Contour.....1116-1117
 Soapstone.....1143
 Whiteboard.....823, 1569

Marking Flags.....871
Marking Paint.....1038, 1040
Marking Paint Applicator.....1040
Marking Wands.....1038-1040
Masking Tape.....1414
 Painter's.....1050

Masks
 CPR.....729-730, 762-763
 Dust.....447, 453

Material Handling
 Box Trucks.....166, 172-175
 Cargo Bars.....212, 1457
 Carts.....660, 662
 Conveyors.....224-225
 Decking & Shoring Beams.....212, 1457
 Dollies.....20, 97, 103, 176-177, 208-209, 1078
 Drywall Carts.....159
 Engine Stands.....208
 Forklift Bump Guard.....186
 Forklift Checklist Kit.....187
 Forklift Extensions.....141, 187, 242
 Forklift PPE Battery Kit.....186
 Gas Cylinder Trucks.....1078
 Hand Trucks.....144-146, 148-151, 1454, 1554
 Hoppers.....171
 Lifting Equipment.....144, 178-202, 206-208, 212, 489, 519, 703, 1298
 Load Binders.....192

Lumber Carts.....159-160
 Pallet Turntables.....181
 Panel Trucks.....158-160
 Pipe Trucks.....160-161
 Platform Trucks.....152-158, 160, 165
 Reel Dispensers.....167
 Reel Racks.....78
 Security Carts.....77
 Semi-Live Skids.....154, 158
 Shop Carts.....7-8, 42, 73, 76-77, 161-170
 Stands.....207, 209
 Step Ladder Hand Truck.....1581
 Stock Trucks.....166
 Tilt Trucks.....172-173
 Tricycles.....161
 Wagons.....154, 157, 370
 Winches.....195
 Wire Spool Carts.....167
 Work Positioners.....181
 Work Stands.....209, 225

Mats, Grounding.....904

Matting
 Anti-Fatigue.....891-894, 896-897, 899-900, 902-909
 Anti-Static.....560, 903-904
 Clean Room.....907
 Eco.....886
 Entrance.....874, 885-888, 901, 909
 Eyewash Stations.....727, 893
 Runner.....885-888, 901, 909
 Welding.....904, 1119
 Wiper.....874, 885-887

Measurement Devices
 Laser Distance Kits.....1482
 Measuring Counters.....1484
 Tape.....1276-1279, 1309-1312
 Wheels.....1278, 1482, 1484
 Wire Measurers.....1484

Measures, Liquid.....993

Measuring Counters.....1484
Measuring Cups.....317, 994

Measuring Tape
 Oil Gaging.....1279
 Reel.....1279
 Retractable Blade.....1276-1278, 1309-1312

Measuring Wheels.....1278, 1482, 1484

Mechanical Filters.....1059
Mechanic's Dollies.....209
Media, Sandblasting.....1055
Media Recyclers, Sandblasting.....1055-1056

Medicine
 Acetaminophen.....752
 Antacids.....752
 Cough and Cold Relief.....752
 Ibuprofen.....752

Megaphones.....444
Mesh Enclosures.....90
Mesh Partitions.....51, 84-85, 88-89
Message Pads.....1579
Metal Markers.....1444
Metal Snips.....1357-1359
Metal Working Fluids.....1145, 1148-1149
Microfiber Cloths.....293-294
Micrometer, Vernier.....1275
Micrometers, Digital.....1275
Microwave Ovens.....1584
MIG Guns.....1094-1096
MIG Pliers.....1088
MIG Welders.....1092-1093

MIG Wire
 Aluminum.....1138
 Bronze.....1138
 Copper.....1138
 Steel.....1135, 1137

Mini Die Grinders, Air.....1215

Mirrors
 Bathroom.....350
 Convex.....882
 Dome.....881, 883
 Flat.....882
 Inspection.....883

INDEX

| | |
|--|---------------------|
| Rectangular..... | 882 |
| Round..... | 882 |
| Mitre Saw Blades | 1203 |
| Mitre Saws | 1175-1176 |
| Mitts, Heat Resistant | 622 |
| Mixers | |
| Drum..... | 249 |
| Pail..... | 249 |
| Paint..... | 1046 |
| Mixing Valves, Thermostatic | 721 |
| Mobile Bins | 6 |
| Moisture Meters | 1477 |
| Mold Release Lubricants | 1009 |
| Monitor Mounts | 1558 |
| Monitor Stands | 1577 |
| Mops | |
| Cotton..... | 304-305 |
| Dust..... | 293, 295 |
| Microfibre..... | 295 |
| Poly / Mesh..... | 305 |
| Polyester / Rayon..... | 304 |
| Sponge..... | 292-293 |
| Wet..... | 292-295, 304-306 |
| Motor Oil | 1015 |
| Motor Rotation Testers | 1468 |
| Motors, Coring | 1189 |
| Mounts | |
| Cupmounts..... | 1272 |
| Leveling..... | 1272 |
| Monitor..... | 1558 |
| Moving Supplies | |
| Cargo Nets..... | 1455 |
| Jack Bars..... | 1457 |
| Logistic Tracks..... | 212, 1457 |
| Moving Blankets..... | 1454 |
| Straps..... | 150, 246, 1454-1456 |
| Tie-Downs..... | 683, 1455-1457 |
| MSDS | |
| Binders..... | 849 |
| Information Centers..... | 848-849 |
| Storage Boxes..... | 667 |
| Muffs | |
| Cap Mounted..... | 433-439 |
| Headband..... | 433-438, 549 |
| Headstrap..... | 433-438, 549 |
| Hearing..... | 435 |
| Neckband..... | 434, 436-437 |
| Multi-Gas Detectors | 482-486 |
| Multi-Gas Meters | 483 |
| Multimeters | |
| AC/DC..... | 1460, 1462 |
| Electrical..... | 1460 |
| True RMS..... | 1460 |
| Multi-Purpose Greases | 1011, 1018 |
| Multi-Purpose Hand Tools | 1355 |
| Multi-Purpose Ladders | 131-132, 1150 |
| Multi-Tip Screwdrivers | 1340-1341 |
| -N- | |
| Nail Guns | |
| Cordless..... | 1163 |
| Electric..... | 1446 |
| Nails, for Nail Guns | 1446 |
| Napkin Dispensers | 343-344, 1583 |
| Napkins | |
| Cafeteria..... | 343-344, 1583 |
| Sanitary..... | 348 |
| Neck Protectors, Welding | 1125 |
| Neck Shades, Cooling | 647 |
| Needle Nose Pliers | 1349, 1351 |
| Nesting Bins | 18-19, 26 |
| Nets | |
| Cargo..... | 1455 |
| Hair..... | 526-527 |
| Neutralizers | |
| Battery Acid..... | 686, 1037 |
| Spill Control..... | 686, 697 |
| Newsprint | 1428 |
| Nibblers | 1173 |
| Nippers, End Cut | 282, 383, 1357 |

| | |
|---|-----------------|
| Nipples, Pipe Thread | 1240, 1243-1244 |
| No Smoking Signs | 806-808, 810 |
| Non-Aqueous Developers | 1144 |
| Non-Chlorinated Cleaners | 1020, 1144 |
| Non-Chlorinated Degreasers | 1144 |
| Non-Chlorinated Developers | 1020, 1144 |
| Non-Sparking Tool Kits | 1386 |
| Non-Sparking Tools | |
| Chisels..... | 1381 |
| Hammers..... | 1380, 1386 |
| Hex Keys..... | 1383 |
| Mallets..... | 1380 |
| Pliers..... | 1383, 1386 |
| Scrapers..... | 1382, 1386 |
| Sockets..... | 1385 |
| Spatulas..... | 1382 |
| Wedge..... | 1381 |
| Wrenches..... | 1384-1386 |
| Nose Cutting Pliers | 1350, 1353 |
| Nozzle Cleaners | 1143 |
| Nozzle Gels, MIG Gun | 1145 |
| Nozzle Reamers | 1088 |
| Nozzles | |
| Garden Hose..... | 376-377 |
| MIG Gun..... | 1095-1098 |
| TIG Torch..... | 1104-1106 |
| Numbered Tags | 793 |
| Numbers, Self-Adhesive | 800 |
| Nut Drivers | |
| Cushion Grip..... | 1342 |
| Hollow Shaft..... | 1342 |
| Insulated..... | 1378 |
| Magnetic..... | 1342 |
| Sets..... | 1342 |
| Nuts, Hex | 85, 89 |
| Nutsetters | 1343 |

-O-

| | |
|---|----------------------------------|
| Odour Neutralizers, Footwear | 750 |
| Office, Dry Erase Whiteboard Wipes | 1569 |
| Office Desks | 1567 |
| Office Fans | 1499 |
| Office Seating | 1546, 1548-1549, 1553-1554 |
| Ergonomic..... | 1547-1549, 1554 |
| Office Supplies | |
| Binders..... | 1579 |
| Clipboards..... | 1579 |
| Corkboards..... | 1569 |
| Desk Organizers..... | 1577 |
| Directory Boards..... | 1569 |
| Display Hangers..... | 1435 |
| Dry Erase Whiteboard Wipes..... | 1569 |
| File Folders..... | 1564, 1579 |
| Filing Boxes..... | 1564 |
| Grounding Mats..... | 904 |
| Hi-Liters..... | 1578 |
| Literature Displays..... | 1568 |
| Markers..... | 823, 846, 1442, 1445, 1569, 1578 |
| Message Pads..... | 1579 |
| Monitor Mounts..... | 1558 |
| Paper Clamps..... | 1565 |
| Paper Clips..... | 1580 |
| Pencil Sharpeners..... | 1578 |
| Pencils..... | 729, 732-733, 1578 |
| Pens..... | 1578 |
| Printer & Photocopier Paper..... | 1579 |
| Push Pins..... | 1569 |
| Rubber Bands..... | 1423, 1580 |
| Sheet Protectors..... | 1579 |
| Staples..... | 1446 |
| Suggestion Boxes..... | 1581 |
| Tape..... | 1580 |
| Tape Dispensers..... | 1580 |
| Whiteboards..... | 1569 |
| Offset Wrenches | 1373 |
| Oil | |
| Air Tool..... | 1037, 1261 |
| Machinery..... | 1011 |
| Oil Cans | 999 |

| | |
|---------------------------------------|----------------------------------|
| Oily Waste Cans | 670-671 |
| Ointments, Burn Care | 749 |
| Omni-Directional Stands | 225 |
| Open End Wrenches | 1335 |
| Open Wire Workstations | 118 |
| Openers, Pail | 250 |
| Oral Thermometers | 756 |
| Orbital Sanders, Air | 1207, 1211-1212, 1218-1219 |
| Order Picking Carts | 165 |
| O-Rings, MIG Gun | 1095 |
| ORP Meters | 1490 |
| Oscillators, Garden Hose | 376 |
| Outdoor Equipment | |
| Bicycle Racks..... | 379 |
| Grounds Maintenance..... | 172, 320, 364-373, 376-378, 1381 |
| Park Benches..... | 380 |
| Picnic Tables..... | 380 |
| Snow Removal..... | 364, 871 |
| Outfits, Welding | 1062-1064 |
| Outlet Adaptors, GFCI | 1540 |
| Outlet Boxes, GFCI | 1539 |
| Oval Sleeves | 194 |
| Oven Cleaners | 316 |
| Ovens, Electrode | 1089 |
| Overalls | |
| Arc Flash..... | 555-556 |
| Flame Resistant..... | 555-556 |
| Rain..... | 542 |
| Overboots | 633 |
| Overpack | 689-690, 693, 697, 700-702, 713 |
| Overshoes | 633-634 |
| Oxygen Hoses, Welding | 1075 |
| Oxygen Masks, Kits | 763 |

-P-

| | |
|----------------------------------|---|
| Packaging | |
| Benches..... | 1433 |
| Boxes..... | 1431 |
| Bubble Pouches..... | 1435 |
| Bubble Wrap..... | 1427 |
| Bungee Cords..... | 1455, 1457 |
| Cable Tie Tools..... | 1452 |
| Cable Ties..... | 793-794, 1435, 1452 |
| Corrugated Paper..... | 1430 |
| Desiccants..... | 1429 |
| Edge and Corner Protectors..... | 48, 86-87, 216, 1421, 1423 |
| Flexible Netting..... | 1430 |
| Foam..... | 1427 |
| Handling Labels..... | 1429-1430, 1448 |
| Knife Blades..... | 1425, 1430, 1434, 1438-1442 |
| Knives..... | 1309, 1312, 1425, 1430, 1434, 1438-1442 |
| Kraft Paper..... | 1428, 1430 |
| Loosefill..... | 1428 |
| Mailers..... | 1434-1435 |
| Moving Straps..... | 150, 246, 1454-1456 |
| Newsprint..... | 1428 |
| Packing List Envelopes..... | 1449 |
| Pads..... | 1431 |
| Poly Bags..... | 1436 |
| Poly Tubing..... | 1430, 1437 |
| Rope..... | 1450 |
| Shrink Wrap..... | 1426 |
| Shrink Wrap Machines..... | 1426 |
| Staple Removers..... | 1447 |
| Staplers..... | 1446-1447 |
| Staples..... | 1446-1447 |
| Strapping..... | 1419-1422 |
| Stretch Wrap..... | 1424-1426 |
| Stretch Wrap Dispensers..... | 1424-1426 |
| Tape..... | 829, 1410-1416, 1429, 1436 |
| Tape Dispensers..... | 1411-1413, 1416, 1429 |
| TDG Labels..... | 855, 1448 |
| Temperature Labels..... | 1429 |
| Tie-Downs..... | 683, 1455-1457 |
| Pail Dollies | 244 |
| Pail Funnels | 699 |
| Pail Heaters | 237 |
| Pail Inserts | 235 |
| Pail Mixers | 249 |
| Pail Openers | 250 |
| Pail Tipplers | 245 |
| Pail Tumblers | 248 |
| Pails | 27, 695-696 |
| Pain Relievers | 752 |
| Paint | |
| Acrylic..... | 1040, 1042-1044 |
| Alkyd..... | 1040-1041, 1043-1044 |
| Antislip..... | 1045 |
| Applicator..... | 1040 |
| Epoxy..... | 1042-1043 |
| Floor..... | 1019, 1044-1045 |
| High Heat..... | 1042-1043 |
| Latex..... | 1042 |
| Line Striping..... | 1039 |
| Marking..... | 1038, 1040 |
| Rubber..... | 1012, 1015, 1045 |
| Paint Accessories | 1046, 1050, 1054 |
| Paint Brushes | 1046-1049 |
| Paint Markers | 1142, 1442-1444 |
| Paint Remover | 1039 |
| Paint Roller Covers | 1049-1051 |
| Paint Rollers | 1049-1051 |
| Paint Stencils | 797-798 |
| Paint Sticks | 1142, 1443-1444 |
| Paint Supplies | |
| Accessories..... | 1046, 1050, 1054 |
| Brushes..... | 1046-1049 |
| Cloths..... | 1054 |
| Drop Sheets..... | 1054 |
| Foam Rollers..... | 1049 |
| Paint Remover..... | 1039 |
| Paint Thinner..... | 1037 |
| Roller Covers..... | 1049-1051 |
| Rollers..... | 1049-1051 |
| Sponging & Ragging..... | 1050 |
| Wall Barriers..... | 1054 |
| Paint Thinner | 1037 |
| Painting Supplies | |
| Extension Poles..... | 287-288, 292-294, 297-299, 302, 1048 |
| Masking Tape..... | 1050 |
| Mixers..... | 1046 |
| Paint Guns..... | 1051 |
| Paint Sprayers..... | 1042, 1051 |
| Paint Trays..... | 1050 |
| Pallet Covers | 1423 |
| Pallet Lifters | 181, 184, 201 |
| Pallet Pullers | 186 |
| Pallet Racks | 49-51 |
| Pallet Servers | 239 |
| Pallet Tilters | 184 |
| Pallet Top Sheet | 1423 |
| Pallet Trucks | 144, 182-186 |

| | | | | | | | |
|---|-------------------------------|-------------------------------------|------------------------------------|---|-----------------------------|---|--------------------------------|
| Pallets | | Eyewear..... | 386-408, 412, | Structural Foam Deck..... | 157 | Power Sockets | 1323, 1327 |
| Aluminum..... | 48 | | 689-697, 1120, 1310-1311 | Wood Deck..... | 153-154 | Power Strips, GFCI | 1540-1542 |
| Plastic..... | 46-48, 1423 | Faceshields | 410-413, 557 | Platforms | | Power Tools | |
| Spill Control..... | 704-708, 710, 713-714 | Fingercots | 600 | Maintenance..... | 141 | Balancers..... | 203 |
| Palm Sanders | 1180 | Footwear | 289, 527, 534, 631-638, 889 | Work..... | 135-136, 906 | Combo Kits..... | 1164-1166 |
| Panel Trucks | 158-160 | Forearm Protectors | 528-529, 534, 643 | Pliers | | Demolition Hammers..... | 1187 |
| Panels, Bins | 7 | Gloves | 549, 558-559, 562-629, 644, 656, | Bolt Holder..... | 1349 | Dremel Tools..... | 1192 |
| Pans, Drip | 252, 680-681 | | 729-735, 762, 1129-1131, 1310-1311 | Chain Nose..... | 1348 | Drill / Drivers...1156-1158, 1161, 1164, 1182 | |
| Pants | | Headwear | 414-418, 526-527 | Combination Slip-Joint..... | 1377 | Drill Chucks..... | 1268-1269 |
| Arc Flash..... | 554 | Hearing Bands | 430-431 | Convertible..... | 1353 | Drills..... | 1158-1159, 1182-1187 |
| Flame Resistant..... | 554 | Knee Pads | 639-640, 1133 | Crimping Die..... | 1349, 1377 | Grinders..... | 916-917, 1163, 1168-1172, 1270 |
| General Protection..... | 534 | Mitts | 622 | Cutting..... | 1309-1312, | Hammer Drill / Drivers..... | 1157-1159 |
| Rain..... | 541, 551-552 | Respirators | 447-466, 469-473, 475, 477, | | 1348-1351, 1353, 1377, 1383 | Heat Guns..... | 1190-1191 |
| Work..... | 550, 552 | | 479-481, 1122, 1127 | Lineman's..... | 1309-1312, 1348 | Impact Wrenches..... | 1159-1160, 1181 |
| Paper | | Shin Guards | 638 | Locking..... | 1288, 1309-1312, | Knockout..... | 1162 |
| Corrugated..... | 1430 | Petroleum Jelly | 749 | | 1351-1352, 1354 | Nail Guns..... | 1163, 1446 |
| Kraft..... | 1428, 1430 | pH Meters | 1490 | Long Nose..... | 1309-1312, 1348, 1351, 1377 | Nibblers..... | 1173 |
| Printer & Photocopier..... | 1579 | Pharmaceutical Products | | MIG..... | 1088 | Power Scrapers..... | 1186 |
| Tissue..... | 1428 | Cream Dispensers..... | 331 | Needle Nose..... | 1349, 1351 | Rotary Hammers..... | 1159, 1185-1187 |
| Toilet..... | 340, 345-346 | Hand Creams..... | 331, 333 | Non-Sparking..... | 1383, 1386 | Sanders..... | 1180 |
| Paper Bags | 1435 | Hand Sanitizers..... | 323-324, 333, 760 | Pump..... | 1377 | Saws..... | 872, 914, 1162-1163, 1174-1179 |
| Paper Clamps, Hanging | 1565 | Insect Repellent..... | 335, 384 | Retaining Ring..... | 1353 | Screw Guns | |
| Paper Clips | 1580 | Insect Sting Relief..... | 749 | Round Nose..... | 364 | Screwdrivers..... | 1161, 1187 |
| Paper Cutters | 1427, 1432-1433 | Medicine..... | 752 | Sets..... | 1354 | Shears..... | 1173 |
| Paper Towel Dispensers | 340-343, 1583 | Petroleum Jelly..... | 749 | Slip Joint..... | 1309-1312, 1348-1349 | Power-Lock Discs | 924-925, 935 |
| Paper Towels | 341-344, 346 | Skin Conditioners..... | 333 | Snipe Nose..... | 1377 | PPE Battery Kit, Forklift | 186 |
| PAPR Respirators | | Skin Creams..... | 333 | Tongue & Groove..... | 1309-1312, 1348-1349 | Precision Screwdrivers | 1341 |
| | 466, 470-481, 1122, 1127 | Sunscreens..... | 335, 384 | Vise Grips..... | 1352 | Prentice Drill Bits | 969-970 |
| Parade / Waiter's Gloves | 625 | Phase Rotation Testers | 1468 | Wire Stripping..... | 1377 | Presses, Arbor | 208 |
| Parallel Clamps | 1286-1287 | Phillips® Bits | 1345 | Plugs | | Pressure Gauges | |
| Park Benches | 380 | Phillips® Screwdrivers | 1309-1312, | Electrical..... | 1084 | Dial..... | 1058 |
| Parkas | 552, 555 | | 1338-1341, 1378, 1383, 1386 | GFCI..... | 1540 | Dry..... | 1489 |
| Parking Curbs, Traffic Control | 861 | Photocopier Paper | 1579 | Plumb Bobs | 1279, 1283 | Liquid Filled..... | 1489 |
| Parking Signs | 810, 820 | Picks | 368, 1381 | Plumbers' Putty | 1022 | Tire..... | 1224 |
| Particulate | 685 | Picks & Hooks | 1307 | Plunger Cans | 670 | Pressure Sensitive Letters | 800 |
| Partitions | | Pick-up Magnets | 1297-1298 | Plungers, Toilet | 349 | Pressure Sensitive Numbers | 800 |
| Column Protectors..... | 86 | Picnic Tables | 380 | Pneumatic Fitting Lockouts | 1250 | Pressure Washers | 374-375 |
| Enclosures..... | 866 | Pictograms | | Pneumatic Pipe Fittings | | Prick Punches | 1370 |
| Fences..... | 865 | Right-To-Know..... | 846 | | 1228, 1240-1244, 1247 | Primers, Adhesive | 1032 |
| Gates..... | 82-84, 216, 309, 866-867, 878 | WHMIS..... | 845-846 | Pneumatic Piping | 81 | Print Holders | 1298 |
| Guard Rails..... | 54, 84-85, 489 | Pillows, Spill Control | 680 | Pneumatic Tube Fittings | 1239, 1248 | Printer Paper | 1579 |
| Manhole Shields..... | 489, 491 | Pin Face Spanners | 1330 | Pneumatic Tubing | 1239 | Privacy Shower Curtain | 727 |
| Perimeter Guards..... | 51, 84-85, 88 | Pin Punches | 1309-1310, 1312, 1368-1370 | Pocket Gauges | 1275 | Probes | |
| Steel Mesh..... | 51, 84-85, 88-89 | Pinch Bars | 1367, 1380 | Pocket Knives | 1355 | Temperature..... | 1471, 1475, 1488 |
| Strip Curtain Doors..... | 91-93 | Pins, Push | 1569 | Pocket Levels | 1115 | Test..... | 1463 |
| Parts Cleaning | | Pipe Cements | 1022 | Poly Bags | 1436 | Process Gauges | 1489 |
| Bench Cans..... | 992 | Pipe Contour Markers | 1116-1117 | Poly Tubing | 1430, 1437 | Propane Hoses, Welding | 1068 |
| Brushes..... | 993 | Pipe Fittings | | Polyethylene Foam Tape | 1416 | Propane Torches | 1064 |
| Dip Tanks..... | 992 | Kee Klamp®..... | 79-81 | Pools, Spill Control | 694, 711 | Protective Wear Signs | 806, 809 |
| Dipping Baskets..... | 992 | Lubrication..... | 999-1001 | Porosity Detectors | 1478 | Provioline® Solution | 748 |
| Parts Washers..... | 993, 995 | Pneumatic..... | 1228, 1240-1244, 1247 | Portable Belts | 928 | Pruners, Tree | 369 |
| Rinse Tanks..... | 992 | Pipe Flange Aligners | 1115-1116 | Portable Blasters , | | Pry Bars | |
| Wash Tanks..... | 992 | Pipe Markers | 833-841 | Sandblasting..... | 1055, 1057 | Crate Openers..... | 1380, 1386 |
| Parts Storage Carts | 42 | Pipe Taps | 960, 973 | Portable Blowers | 359, 488, 1059-1060 | Multi-Purpose..... | 1309-1312, 1366 |
| Parts Washers | 993, 995 | Pipe Tools | | Portable Buildings , | | Nail Pullers..... | 1366, 1380 |
| Cleaning Fluids..... | 995 | Clamps..... | 1285 | Smoking Shelters..... | 381 | Non-Sparking..... | 1380 |
| Patches, Eye | 728, 730, 735 | Contour Markers..... | 1116-1117 | Portable File Belts | 928 | Rolling Head..... | 1367 |
| Pavement Tape | 868 | Flange Aligners..... | 1115-1116 | Portable Heaters | 1504 | Tack Pullers..... | 1340 |
| Pedestal Fans | 1497-1499 | Flaring Tools..... | 1374 | Portable Scales | 1492-1494 | with Handle..... | 1367 |
| Pencil Grinders, Air | 1223 | Jacks..... | 1115 | Portable Sheds | 381 | Pry Dollies | 177 |
| Pencil Sharpeners | 1578 | Wrenches..... | 1309, 1372-1373, 1378 | Posidriv® Bits | 1345 | Psychrometers | 1475 |
| Pencils | 729, 732-733, 1578 | Pipe Trucks | 160-161 | Positioners, Work | 181 | PTC Fittings | 1239 |
| Grease..... | 1142, 1445 | Pipefitting Levels | 1115-1117 | Positioning and Restraint Lanyards | 508 | Pullers | |
| Penetrants | | Piping | | Positive Pressure Respirators | | Pallet..... | 186 |
| 5-Way..... | 1013 | Kee Klamp®..... | 81 | | 466, 470-481, 1122, 1127 | Pilot Bearing..... | 1365 |
| Bolt Removal..... | 1013 | Pneumatic..... | 81 | Postal Tubes | 1434 | Pump Lubricants | 1144 |
| KB 88..... | 1013 | Placards, TDG | 851-854 | Posters | | Pump Pliers | 1377 |
| Multi-Purpose..... | 1013 | Plasma Cutter Guides | 1069 | SDS..... | 847 | Pump Wrenches | 1335 |
| Water Based..... | 1144 | Plasma Cutters | 1090 | WHMIS..... | 847 | Pumps | |
| WD-40®..... | 1004, 1012-1013 | Plastic Bandages | 729-735, 741-742, 745 | Posts | | Air Operated..... | 258 |
| Penlights | 1512 | Plastic Strips | 734, 742 | Crowd Control..... | 821, 874-880 | Cam & Groove Fittings..... | 263 |
| Pennants, Traffic Control | 871 | Plates | | Snow Clearing..... | 871 | Coolant Tanks..... | 1150 |
| Pens | | Cafeteria..... | 1583 | Pot Brushes | 26, 301 | Diaphragm..... | 258 |
| Office..... | 1578 | Styrofoam..... | 1583 | Pouch Tape | 1449 | Discharge Hoses..... | 263 |
| pH..... | 1490 | Platform Ladders | 127, 129-131, 135 | Pouches | | Drum..... | 254-258 |
| Perimeter Guards | 51, 84-85, 88 | Platform Scales | 1494-1495 | Bubble..... | 1435 | Engine-Powered..... | 264 |
| Permanent Markers | 1442, 1445, 1578 | Platform Trucks | | Tool..... | 523, 1387-1388, 1390-1392 | Grease..... | 999-1000 |
| Personal Protection | | Aluminum Deck..... | 155-156 | Powder, Scouring | 316 | Hand..... | 254-256, 258-259 |
| Dust Masks..... | 447, 453 | Dead Skids..... | 154 | Power Bars | 1541 | Lever..... | 256 |
| Ear Muffs..... | 433-439, 549 | Non-skid Vinyl Deck..... | 156 | Power Cable Adapters, TIG Torch | 1109 | Lockouts..... | 259 |
| Ear Plugs..... | 423-429, 431 | Plastic Deck..... | 156-158 | Power Cables, TIG Torch | 1110 | Machine Tool..... | 1150 |
| Elbow Protectors..... | 643 | Semi-Live Skids..... | 154, 158 | Power Scrapers | 1186 | Rotary..... | 256-258 |
| | | Steel Deck..... | 152-153, 155, 160, 165 | | | | |

INDEX

Submersible.....262-263, 1150
Transfer.....258, 263, 671

Punches
Aligning.....1369
Center.....1309-1310, 1312, 1368, 1370
Drift.....1309-1310, 1369-1370
Drive Pin.....1369
Pin.....1309-1310, 1312, 1368-1370
Prick.....1370
Starting.....1370

Purifiers, Air.....1500

Push Brooms.....287-290, 301

Push Pins.....1569

Push to Connect Fittings.....1239

Putty Knives.....1052
Flexible.....1052, 1382
Stiff.....1052, 1382, 1386

-Q-

Quick Clamps.....1288

Quick Couplers.....1207, 1233, 1246, 1248-1250

Quick-Connects, Welding.....1074

-R-

Rack, Carton.....1434

Racks
Bar.....53
Bicycle.....379
Bin.....8-9, 11, 39, 121
Broom & Mop.....286
Cantilever.....52
Coat.....1581
Drum.....245, 703
Gas Cylinder.....1079
Key.....1570
Pallet.....49-51
Reel.....78
Sheet.....53
Stacking.....41, 53-54, 157
Threaded Rod.....45
Tire.....78
Welding.....1078

Radiant Heaters.....1503-1505

Radiator Heaters.....1503

Radios, Two-Way.....435, 438-439, 441-442

Rafter Squares.....1280

Rag Rugs, Spill Control.....679

Rags.....338, 1054

Rail, Grab.....350

Rail Chocks.....210

Rainwear
Flame Resistant.....541-542, 548
Hoods.....541-543, 548
Jackets.....541-542, 551
Overalls.....542
Pants.....541, 551-552
Suits.....540, 543

Rakes.....367

Ramps
Twin.....214
Walk.....214

Rare Earth Magnets.....1299

Rasps
Half Round.....1305
Round.....1305

Ratchet Counters.....1483

Ratchet Straps.....1456

Ratchet Wrenches, Air.....1206, 1210

Ratcheting Wrenches.....1333-1334

Ratchets
1 1/2" Drive.....1324
1" Drive.....1324
1/2" Drive.....1315, 1317-1318, 1320-1321
1/4" Drive.....1317, 1324
3/4" Drive.....1322
3/8" Drive.....1316, 1318-1319

Razor Blades.....1052

Reamers
Adjustable.....985
Chucking.....981-985
Hand.....981
Nozzle.....1088
Taper Pin.....982

Rebar Cutters.....1361

Rebar Tie Wire Cutters.....1350

Receiving Scales.....1494

Receptacles
Electrical.....1084
Sanitary Napkin.....348-349

Reciprocating Saw Blades.....1201

Reciprocating Saws
Air.....1214
Cordless.....1163
Electric.....1179

Record Storage, Shelving.....57

Recycling Containers.....276-279, 1577

Reel Dispensers.....167

Reel Racks.....78

Reels
Cord.....1531-1532, 1537
Hose.....1076, 1234-1237, 1532
Welding.....1076

Refacers, Welding Tip.....1073

Reflectors, Traffic Control.....859

Refractometers.....1490

Refrigerators.....1584

Regulator, Calibration Gas.....484-486

Regulator/Flowmeters, Welding.....1068

Regulators
In-Line.....1232, 1256, 1261
Welding.....1064, 1066-1069

Rehydration Drinks, Sqwincher®.....648-649

Repair Kits, Hose.....377

Repellent, Insect.....335, 384

Rescue Hoist.....492

Rescue Systems.....490-492, 496, 518

Resin Fibre Discs.....922-923, 925

Respirators
Ambient Air Pump.....466, 481, 1127
Cartridges.....456, 460-464, 466, 470, 472-473, 475, 477, 480
Disposable.....447-453
Emergency Escape.....459
Filters.....452, 456-459, 461, 464, 475, 480
Fit Test Kits.....465
Full Face.....455, 458-459, 462-463, 469
Half Mask.....454-455, 458, 461-464, 469
Headgear.....473, 479, 1127
PAPR.....466, 470-481, 1122, 1127
Positive Pressure.....466, 470-481, 1122, 1127
SCBA.....469
Supplied Air.....466, 479
Welding.....450

Retaining Compounds.....1027

Retaining Ring Pliers.....1353

Retaining Rings, MIG Gun.....1095

Revolving Bins.....29

Right-To-Know Pictograms.....846

Rings, Key.....794

Rinse Tanks.....992

Risers, Dock.....215

Robertson® Screwdrivers.....1309-1312, 1338-1340

Rockers, Drum.....245

Rod / Electrode Containers.....1089, 1134

Rods, TIG.....1136-1138, 1140

Rollers
Fountain.....799
Hand.....799
Machinery.....204-205

Rolling Head Bars.....1367

Rolling Knee Dollies.....209

Rolling Ladders.....135, 137-140

Rolling Workbenches.....125

Rolls
Cartridge.....929
Spill Control.....673-678, 689-690
Surface Conditioning.....930, 933-934

Roofing Knives.....1441

Rope
Crowd Control.....879
Packaging.....1450

Rope Ends, Crowd Control.....879

Rope Grabs.....517-518, 520

Rotary Cutters.....1163

Rotary Hammer Bits.....1195-1196

Rotary Hammers.....1159, 1185-1187

Rotary Pumps.....256-258

Rotary Sanders, Air.....1211

Rotators, Drum.....239, 248

Round Files.....1302, 1304

Round Nose Pliers.....364

Round Point Shovels.....366, 1381

Round Rasps.....1305

Rubber Bands.....1423, 1580

Rubber Coating.....1012, 1015, 1045

Rubber Cutting Knives.....1371, 1441

Rubber Paint.....1012, 1015, 1045

Rubbing Alcohol.....748

Runner Matting
Carpet.....886-887
Needle Rib.....885
Pile.....885-888
Polypropylene.....885
Rubber.....888, 901, 909
Vinyl.....901

Rust Converters.....1014, 1146, 1148

Rust Preventers.....1014, 1146

Rust Removers.....1014, 1146

-S-

Safes.....1562, 1577

Safety
Anti-Skid Cleats.....872
Arm Protection.....528-529, 534, 643
Cans.....668-669
Cones.....48, 308, 1423
Cooling Clothing.....645-647
Crowd Control.....794, 821, 874-880
Ear Protection.....423-431, 433-439, 549
Ergonomic Products.....639-644, 746, 1133
Eyewear.....386-408, 412, 689-697, 1120, 1310-1311
Faceshields.....410-413, 557
Fall Protection.....141, 490-492, 494-502, 507-510, 512-520, 522-524, 560
Fire Protection.....651-656, 753
First Aid.....335, 384, 716-763
Flame Resistant Clothing.....541-542, 548
Floor Signs.....296, 308
Flooring.....872-873, 906
Foot Protection.....289, 527, 534, 631-638, 889
Gas Detectors.....482, 484-486
Hand Protection.....549, 558-559, 562-629, 644, 656, 729-735, 762, 1129-1131, 1310-1311
Headwear.....414-418, 526-527
High Visibility Clothing.....543, 545-549, 551
Hygienic Products.....325, 329, 348-349, 731, 734, 751, 758
Insect Repellent.....335, 384
Locking Systems.....654, 770, 782, 1562, 1570, 1577
Lockouts.....106, 259, 764, 768-769, 772-784, 786-790, 1250
Matting.....560, 727, 891-894, 896-897, 899-900, 902-909, 1119
Medicine.....752
Mirrors.....881-883
Oxygen Masks.....763
Padlocks.....99, 110, 764-773
Pharmaceutical.....323-324, 331, 333, 335, 384, 749, 760
Rehydration Drinks.....648-649
Respirators.....447-466, 469-473, 475, 477, 479-481, 1122, 1127
Safes.....1562, 1577
Security Seals.....794, 1451

Shin Guards.....244, 252, 266, 290, 638
Spill Control.....244, 252, 266, 290, 670, 673-687, 689-714, 760
Traffic Clothing.....543, 545-549, 551
Traffic Control.....83, 309, 545-548, 850, 858-864, 867-869, 871, 874
Whips.....856

Safety Pins.....730-735, 751

Safety Signs.....727, 806, 809, 849

Safety Tags.....786-788, 790

Salt.....364

Salt & Sand Containers.....363, 689

Salvage Drums.....689-690, 693, 697, 700-702, 713

Sandblasting Equipment
Dust Collectors.....1056
Guns.....1057, 1225
Media.....1055
Media Recyclers.....1055-1056
Portable Blasters.....1055, 1057
Suction Cabinets.....1056-1057

Sandblasting Gloves.....591

Sanders
Belt.....1180
Belt - Air.....1213, 1216-1217, 1220-1221
Hand.....1053
Orbital - Air.....1207, 1211-1212, 1218-1219
Palm.....1180
Rotary - Air.....1211

Sanding Blocks.....1053

Sanding Sponges.....933

Sandpaper.....930-932

Sanitary Napkin Dispensers.....348

Sanitary Napkin Receptacles.....348-349

Sanitary Napkins.....348

Sanitizing Solution
First Aid Instruments.....751

Saw Blades
Circular Saw.....914, 1202-1203
Combination Saw.....1203
Cut-Off.....1203
Mitre Saw.....1203
Reciprocating Saw.....1201

Sawhorses.....135

Saws
Bandsaws.....1178
Chop.....914, 1174
Circular.....872, 1162, 1177
Drywall.....1053
Framing.....872
Hacksaws.....1300-1301, 1309-1312
Hole.....1197-1198
Jig Saws.....1178
Mitre.....1175-1176
Reciprocating.....1163, 1179
Reciprocating - Air.....1214

Scaffolding.....134, 141-143

Scales, Air.....1207, 1214

Scales
Bench.....1433, 1491-1495
Counting.....1491
Crane.....203, 1496
Dial.....1494
Floor.....1496
Hanging.....203, 1493-1494, 1496
Platform.....1494-1495
Portable.....1492-1494
Receiving.....1494
Utility.....1492-1494
Weighing.....1491-1492

Scaling Chisels.....1088, 1194

Scaling Hammers.....1364

SCBA Respirators.....469

Scissors
Electrician.....1357
First Aid.....729-735, 747
General Purpose.....1356
Industrial.....1356-1357, 1442, 1580

Scoop Shovels.....1381

Scoops
Aluminum.....366, 994
Grain and Coal.....366
Litter.....282, 290, 383

| | | | | | | | |
|---|-----------------------------|---|----------------------------------|---|------------------------------|---|------------------------------|
| Polyethylene..... | 363 | Seating | | Packing List Envelopes..... | 1449 | Kevlar®..... | 529 |
| Polypropylene..... | 694 | Chair Caddies..... | 1554 | Pallets..... | 46-48, 1423 | Nylon..... | 528 |
| Spill Control..... | 687 | Ergonomic..... | 1547-1549, 1554 | Strapping..... | 1419-1422 | Polypropylene..... | 528, 534 |
| Scoreboard Signs | 822-823 | Folding Chairs..... | 382, 1554 | Tamper Seals..... | 1451 | PVC..... | 528-529 |
| Scotch® Tape Dispensers | 1580 | Footrests..... | 1549 | TDG Labels..... | 855, 1448 | SuperFabric®..... | 529 |
| Scotch-Brite™ Deburring Wheels | | Locker Room Benches..... | 108, 382 | Temperature Labels..... | 1429 | Vinyl..... | 528 |
| | 936, 938, 1271 | Office Chairs... 1546, 1548-1549, 1553-1554 | | Shipping & Receiving Signs | 813 | Welding..... | 1132 |
| Scotch-Brite™ Discs | 935 | Stacking Chairs..... | 1555 | Shirts | | Sleigh Shovels | 365 |
| Scouring Pads | 292, 302, 320, 362 | Swivel Stools..... | 1554 | Arc Flash..... | 554 | Slide Hammers | 1365 |
| Scouring Powder | 316 | Task..... | 209, 1134, 1546, 1550-1554 | Flame Resistant..... | 554 | Slings | |
| Scrapers | | Security | | General Protection..... | 534 | Chain..... | 189 |
| Drywall..... | 1052, 1382 | Carts..... | 77 | Work..... | 550 | Drum Lifting..... | 243 |
| Floor..... | 292, 298 | Gates..... | 82-84, 216, 866, 878 | Shock Absorbing Lanyards | 141, 507-510 | Nylon..... | 188 |
| Non-Sparking..... | 1382, 1386 | Locking Systems..... | 99, 110, 654, | Shoe Brushes | 291, 889 | Polyester..... | 188-189 |
| Power..... | 1186 | | 764-773, 782, 1562, 1570, 1577 | Shoe Covers | 289, 527, 889 | Slip Hooks | 192-193 |
| Rubber..... | 886-888 | Lockouts..... | 106, 259, 764, 768-769, | Shop Carts | 7-8, 42, 73, 76-77, 161-170 | Slip Joint Pliers | 1309-1312, 1348-1349 |
| Sidewalk..... | 368 | | 772-784, 786-790, 1250 | Shop Coats | 550 | Slot Drills | 986-987 |
| Spill Control..... | 687 | Safes..... | 1562, 1577 | Shop Cranes | 202, 208 | Slot Screwdrivers | 1309-1312, 1338-1341, |
| Scratch AWL Screwdrivers | 1340 | Seals..... | 794, 1451 | Shop Desks | 102, 126 | | 1378, 1383, 1386 |
| Scratch Brushes | 946-947, 1087 | Self-Adhesive Letters | 800 | Shop Lifters | 180, 703 | Slotted Bits | 1344-1345 |
| Screens | | Self-Adhesive Numbers | 800 | Shop Stands | 207, 209 | Slow Moving Vehicle Signs | 859 |
| Urinal..... | 349 | Self-Retracting Lanyards | | Shop Sweepers | 286, 358 | Small Parts Bins | 25, 31, 39 |
| Welding..... | 1118-1119 | | 492, 512-513, 515 | Shop Tables | 102 | Fiberboard..... | 11 |
| Screw Extractors | 960, 989 | Self-Retracting Life Lines | | Shoring Beams | 212, 1457 | Small Parts Cabinets | |
| Screw Guns | 1187 | | 492, 512-515, 518 | Shovels | | | 30-34, 37-38, 42-43, 45 |
| Screwdriver Bits | | Self-Stick Bandages | 742, 746 | Round Point..... | 366, 1381 | Small Parts Cases | 36 |
| Bit Holders..... | 1343 | Semi-Live Skids | 154, 158 | Scoop..... | 1381 | Smoke Alarm Testers | 656 |
| Cross-Point / Phillips®..... | 1345 | Sensor, Gas Detectors | 484-486 | Sleigh..... | 365 | Smoke Alarms, Ionization | 655 |
| Hex..... | 1344 | Service Benches | 123-125 | Snow..... | 364-365 | Smoke Ejectors | 1501 |
| Hex Square Drives..... | 1340, 1343 | Service Writers | 126 | Spill Control..... | 686 | Smoking Shelters | 381 |
| Nutsetters..... | 1343 | Sets | | Square Point..... | 365-366, 368, 1381 | Snipe Nose Pliers | 1377 |
| Posidriv®..... | 1345 | Cold Chisel..... | 1309, 1367, 1370 | Shower Testers | 726 | Snips | |
| Slotted..... | 1344-1345 | Files..... | 1306-1307 | All Purpose..... | 1357-1359 | | 1357-1359 |
| Square Recess..... | 1344-1345 | Forstner Bit..... | 1200 | Duckbill..... | 1357 | Shower Testers | 1357-1359 |
| Torque..... | 1343 | Nut Driver..... | 1342 | Grape & Orchid..... | 1357 | Shredders, Paper | 1580 |
| Torx®..... | 1343-1344 | Pliers..... | 1354 | Metal Cutting..... | 1358-1359 | Shrink Wrap | 1426 |
| Tri-Wing..... | 1344 | Rotary Hammer Bit..... | 1195 | Shrink Wrap Machines | 1426 | Side Cutting Pliers | 1349, 1351, 1377 |
| Screwdrivers | | Screwdriver..... | 1338-1341, 1383 | Sidewalk Scrapers | 368 | Signal Horns | 444 |
| Air..... | 1207, 1209, 1211, 1222 | Socket..... | 1309-1310, 1312-1315, 1325-1326 | Signs | | Admittance..... | 803-810, 813 |
| Cabinet Tip..... | 1309-1312, 1338-1340, 1383 | Tap & Drill..... | 973 | Aisle..... | 12, 48 | Chemical Hazard..... | 804, 808 |
| Cordless..... | 1161, 1187 | Wrench... 1309-1310, 1312, 1332-1334, 1337 | | Confined Space..... | 758, 804, 808 | CSA Standard..... | 814-817 |
| Cross-Point / Phillips®..... | 1309-1312, | Shampoo | 325, 329 | Direction and Exit..... | 807, 810-811 | Ear Protection..... | 806, 809 |
| | 1338-1341, 1378, 1383, 1386 | Sharps Collectors | 757, 760 | Electrical Hazard..... | 804-805, 808 | Exit..... | 1521 |
| Flat Tip / Slot..... | 1309-1312, 1338-1341, | Shears | | Eye Protection..... | 806, 809 | Fire..... | 653, 807, 810, 812, 817, 822 |
| | 1378, 1383, 1386 | Air..... | 1214 | Fall Protection..... | 806 | First Aid..... | 727, 805, 809, 812 |
| Multi-Tip..... | 1340-1341 | Fabric..... | 1357 | Fire..... | 653, 807, 810, 812, 817, 822 | Floor..... | 296, 308, 813 |
| Precision..... | 1341 | Hedge..... | 369 | Hazardous Materials..... | 808 | Machinery & Operations..... | 804-805, 809 |
| Scratch AWL..... | 1340 | Industrial..... | 1356 | Maintenance..... | 808-809, 813 | No Smoking..... | 806-808, 810 |
| Sets..... | 1338-1341, 1383 | Lopping..... | 369 | Parking..... | 810, 820 | Protective Wear..... | 806, 809 |
| Square / Robertson®..... | | Power..... | 1173 | Safety..... | 727, 806, 809, 849 | Scoreboard..... | 822-823 |
| | 1309-1312, 1338-1340 | Sheathing Tape | 1437 | Shipping & Receiving..... | 813 | Slow Moving Vehicle..... | 859 |
| Torque..... | 1329 | Sheds, Portable..... | 381 | TDG..... | 851-854 | Traffic..... | 210, 807, 810, 812, |
| Torx®..... | 1339, 1341 | Sheet Holders | 1579 | | 820-821, 851, 857-859 | Washroom..... | 813 |
| Scribe Pens | 1212, 1223 | Sheet Protectors | 1579 | Silicone Lubricants | 1008, 1010 | Silver & Deming Drill Bits | 954 |
| Scrub Brushes | 26, 291, 300, 946 | Sheets, Burn Care | 753 | Silver & Deming Drill Bits | 954 | Single Ladders | 127, 132-133 |
| Scrubbers, Hand | 292, 302, 320 | Shelf Bins | 13-15, 25 | Single-Gas Detectors | 482, 485 | Skid Lifts | 181 |
| SDS | | Shelf Carts | | Skid Conditioners | 333 | Skin Creams | 333 |
| Binders..... | 849 | | 73, 76-77, 161-165, 167-168, 170 | Skin Creams | 333 | Sky Hooks | 199 |
| Information Centre..... | 848-849 | Shelters, Spill Control | 708 | Sledge Hammers | | Double Faced..... | 369, 1366 |
| Poster..... | 847 | Shelves, Washroom | 350 | Non-Sparking..... | 369, 1365, 1380 | Sleeves | |
| Sealant, Spill Control | 683, 694 | Shelving, Drawer Insert | 68-69 | Single-Gas Detectors | 482, 485 | Canvas..... | 528 |
| Sealant Tape | 1027-1028, 1416 | Shelving Units | | Cotton..... | 528-529 | Sorters, Mail | 1566 |
| Sealants | | Bin..... | 6, 11, 15-17, 21, 59-60 | | | | |
| Flange..... | 1026 | Chrome..... | 17, 56, 70-72, 74-75 | | | | |
| Foam..... | 1023 | Plastic..... | 75 | | | | |
| Gaskets..... | 1025-1026 | Stainless Steel..... | 78, 99 | | | | |
| Retaining Compounds..... | 1027 | Steel..... | 11, 55-58, 61-67, 78 | | | | |
| Silicone..... | 1025 | Steel Wire..... | 73, 75 | | | | |
| Teflon® Tape..... | 1027-1028, 1416 | Widespan..... | 57 | | | | |
| Thread..... | 1026 | Shields | | | | | |
| Threadlockers..... | 1020, 1027-1028 | CPR..... | 729-735, 762 | | | | |
| Sealers, Floor | 1019 | Face..... | 410-413, 557 | | | | |
| Sealing Press, Security Seals | 794 | Manhole..... | 489, 491 | | | | |
| Sealing Spatula | 1052 | Shims | 1273-1274 | | | | |
| Seals | | Shin Guards, Plastic | 638 | | | | |
| Sealing Press..... | 794 | Shipping | | | | | |
| Security..... | 794, 1451 | Benches..... | 1433 | | | | |
| Steel..... | 1419, 1421 | Cargo Nets..... | 1455 | | | | |
| Tamper..... | 1451 | Handling Labels..... | 1429-1430, 1448 | | | | |
| Seamers, HVAC | 1359 | Jack Bars..... | 1457 | | | | |
| Seat Cover, Automotive | 280, 546 | Logistic Tracks..... | 212, 1457 | | | | |
| | | Mailers..... | 1434-1435 | | | | |
| | | Moving Blankets..... | 1454 | | | | |

INDEX

| | | | | |
|--|--|---|--|---|
| Sound Level Meters | | Stainless Steel Cleaners316, 319, 1004 | Revolving Bins.....29 | Surface Conditioning Belts937 |
| Digital.....440, 1480 | | Stairway Ladders140 | Safety Cans.....668-669 | Surface Conditioning Discs934-936, 938 |
| Integral Probe.....440, 1480-1481 | | Stamps, Hand795-796, 1117 | Salt & Sand Containers.....363, 689 | Surface Conditioning Pads302, 933 |
| Spade Handle Drills1183-1184 | | Stands | Shelf Bins.....13-15, 25 | Surface Conditioning Rolls930, 933-934 |
| Spades | | Automotive.....207, 209 | Shelving Units.....11, 17, 55-58, 61-67, | Surface Mount Thermometers1473 |
| Drain.....366 | | Engine.....208 | 70-75, 78, 99 | Surge Protectors1540-1541 |
| Garden.....366 | | Equipment.....170 | Small Parts Bins.....11, 25, 31, 39 | Surge Suppressors1540, 1542 |
| Spading Forks367 | | Garbage Bag.....383 | Small Parts Cabinets.....30-34, 37-38, 42-43, 45 | Surgical Tape729, 744 |
| Spanner Wrenches1330 | | Gas Cylinder.....1079 | Small Parts Cases.....36 | Suspenders1389 |
| Spanners, Pin Face1330 | | Monitor.....1577 | Stacking Bins.....4-6, 13-17, 21, 26, 40-41 | Sweatbands420, 1133 |
| Spats, Welding1132 | | Work.....209, 225 | Stacking Racks.....41, 53-54, 157 | Sweeper Magnets286 |
| Spatula, Sealing1052 | | Staple Removers, Packaging1447 | Static Bags.....1435 | Sweepers286, 358 |
| Spatulas, Non-Sparking1382 | | Staplers, Packaging1446-1447 | Steel Bins.....40-41, 44-45 | Sweeping Compounds290 |
| Speed Bumps, Traffic Control860 | | Staples | Tanks.....27 | Switch Brooms290 |
| Spill Control | | Carton Staplers.....1446-1447 | Threaded Rod Racks.....45 | Swivel Connectors1219, 1250 |
| Berms.....681, 711-712, 714 | | Office Staplers.....1446 | Tire Racks.....78 | Swivel Stools1554 |
| Brooms.....687 | | Pneumatic Stapler.....1447 | Tool Aprons.....1391 | Synthetic Greases1018 |
| Containers.....709-710 | | Starcarts™.....174-175 | Tool Bags.....1391-1393, 1464 | |
| Drain Protectors.....682 | | Starting Punches1370 | Tool Belts.....1389 | |
| Drain Seals.....681-683, 689-693 | | Static Bags1435 | Tool Boxes.....1309-1311, 1393-1394 | |
| Drip Cans.....670 | | Stations | Tool Cabinets.....103, 1309, 1312, 1395-1400 | |
| Drip Pans.....252, 680-681 | | Docking.....482-483, 485-486 | Tool Carts.....123-125, 1395, 1397, 1400 | |
| Drum Carts.....701 | | Lens Cleaning.....409 | Tool Chests.....1309-1310, 1394-1399, 1402-1403 | |
| Drum Dollies.....244, 266, 701-702 | | Stem Thermometers1473 | Tool Holders.....1387-1388, 1392 | |
| Drum Racks.....703 | | Stencil Inks799 | Tool Pouches.....523, 1387-1388, 1390-1392 | |
| Drum trays.....681, 703, 711, 713 | | Stencils | Transfer Boxes.....19 | |
| Funnels.....699 | | Paint.....798 | Van and Truck Equipment.....1407 | |
| Kits.....689-698, 760 | | Paint & Ink.....797 | Straight Blade Knives1382, 1386 | |
| Leak Diverters.....683 | | Step Cans269-270, 761 | Straight Ladders127, 132-133 | |
| Leak Seal.....683 | | Step Ladder Hand Truck1581 | Straight Line Clamps1290, 1292 | |
| Neutralizers.....686, 697 | | Stepladders127-128, 134-135 | Straight Wrenches1373 | |
| Overpack.....689-690, 693, 697, 700-702, 713 | | Stepstands, Steel135-137 | Strainers, Drum & Pail235 | |
| Pallets.....704-708, 710, 713-714 | | Stepstools | Strap Wrenches1372 | |
| Pools.....694, 711 | | Fiberglass.....134 | Strapping | |
| Salvage Drums.....689-690, 693, 697, | | Polyethylene.....136, 1549 | Buckles.....1420-1422 | |
| 700-702, 713 | | Stethoscopes756 | Dispensers.....1420, 1422 | |
| Scoops.....687 | | Stick Electrodes1136-1137, 1139 | Machines & Tools.....1419-1422 | |
| Scrapers.....687 | | Stick-On Discs926-927 | Poly.....1421-1422 | |
| Sealant.....683, 694 | | Sting Relief, Insect749 | Seals.....1419, 1421 | |
| Shelters.....708 | | Stirring Sticks1583 | Stainless Steel.....1420 | |
| Shovels.....686 | | Stock1274 | Steel.....1419-1420 | |
| Sorbents.....290, 673-680, 684-685, 689-692 | | Stock Picking Carts165 | Tape.....1412 | |
| Spinal Backboard755 | | Stock Trucks166 | Straps, Moving150, 246, 1454-1456 | |
| Spiral Bands929 | | Stools | Straws1583 | |
| Spilts731, 734, 754 | | Swivel.....1554 | Stretch Wrap | |
| Finger.....754 | | Task.....209, 1134, 1550-1554 | Banding Film.....1425 | |
| Leg.....731, 734, 754 | | Stop & Go Lights220 | Blown.....1424 | |
| Sponges, Sanding933 | | Stop Sleeves194 | Cast.....1424, 1426 | |
| Spoons, Cafeteria1583 | | Stopwatches645, 1475, 1483 | Clear.....1424-1425 | |
| Spot Lights187, 1516, 1518 | | Storage | Coloured.....1424 | |
| Spotter, Drum247 | | Bar Racks.....53 | Machine.....1426 | |
| Spray Adhesives1036, 1418 | | Bin Racks.....8-9, 11, 39, 121 | Opaque.....1424 | |
| Spray Bandages742 | | Bin Shelves.....6, 11, 15-17, 21, 59-60 | Stretch Wrap Dispensers1424-1426 | |
| Spray Lubricants1008-1013, 1018, 1543 | | Bottles.....28 | Stretchers | |
| Sprayers | | Cabinet Tables.....124 | Folding.....754 | |
| Lawn & Garden.....320, 371-373 | | Cabinets.....9-10, 35, 94-103, 381, | Wire Basket.....755 | |
| Paint.....1042, 1051 | | 658, 660-667, 1561, 1563 | Striking Face Wrenches1331 | |
| Trigger.....302, 320 | | Cantilever Racks.....52 | String Lights1528 | |
| Spreaders, Adhesive1053 | | Carton Rack.....1434 | Strip Curtain Doors91-93 | |
| Spring Clamps1288 | | Collapsible Containers.....44-45 | Strip Magnets1298 | |
| Sprinklers, Garden Hose376 | | Dispenser Bottles.....672 | Stripping Machines1039-1040 | |
| Spud Wrenches1372 | | Distribution Containers.....18-20, 22-24, 1564 | Strippers, Wire1351 | |
| Square Files1304 | | Drawers.....37 | Stripping Pads362 | |
| Square Point Shovels365-366, 368, 1381 | | Equipment Cases.....1461, 1464-1465, 1471 | Stroboscopes1483 | |
| Square Recess Bits1344-1345 | | ESD Bins.....25 | Structural Adhesives1032-1034 | |
| Square Screwdrivers1309-1312, 1338-1340 | | Food Handling Containers.....175 | Structural Wrenches1330 | |
| Squares | | Gas Cans.....671-672 | Structures | |
| Bevels.....1280-1281 | | Gas Cylinder Brackets.....1079 | Bollards.....54, 85, 87, 865 | |
| Carpenter.....1280 | | Gas Cylinder Cabinets.....1077 | Portable Buildings.....381 | |
| Drywall.....1280 | | Gas Cylinder Racks.....1079 | Portable Sheds.....381 | |
| Rafter.....1280 | | Gas Cylinder Stands.....1079 | Tents.....382, 489, 647 | |
| Try.....1280 | | Horizontal Sheet Rack.....53 | Submersible Pumps262-263, 1150 | |
| Welding.....1086 | | Jars.....28 | Suction Cabinets1056-1057 | |
| Squeezees296-299, 301, 687 | | Jobsite Boxes.....36, 1394, 1401-1407 | Suggestion Boxes1581 | |
| Sqwincher®648-649 | | Lockers.....104-110 | Suits, Rain540, 543 | |
| Stackers | | Mobile Bins.....6 | Sunscreens335, 384 | |
| Drum.....242 | | Nesting Bins.....18-19, 26 | Supermills987 | |
| Stacking Bins4-6, 13-17, 21, 26, 40-41 | | Oily Waste Cans.....670-671 | Supplied Air Respirators466, 479 | |
| Stacking Chairs1555 | | Pallet Racks.....49-51 | Support Bandages731-732, 746 | |
| Stacking Dollies20 | | Paper Bags.....1435 | | |
| Stacking Racks41, 53-54, 157 | | Plunger Cans.....670 | | |
| Stacking Tables1556-1557 | | Poly Containers.....27, 234, 671 | | |



| |
|---|
| T Squares, Drywall1280 |
| Table Caddies1557 |
| Tables |
| Cabinet.....124 |
| Changing.....348 |
| Folding.....382, 1557 |
| Lift.....178-179, 181, 184 |
| Picnic.....380 |
| Shop.....102 |
| Stacking.....1556-1557 |
| Work.....120, 1556, 1561 |
| Tachometers1482 |
| Tags |
| Accident Prevention.....786-788, 790 |
| Blank.....791-793, 1448 |
| Brass.....793 |
| Caution.....790 |
| Danger.....790 |
| Key.....1570 |
| Lockout.....786-790 |
| Magnetic.....12 |
| Numbered.....793 |
| Safety.....786-788, 790 |
| Tally Counters1483 |
| Tamper Proof Torque Mark1342 |
| Tamper Seals1451 |
| Tampers348 |
| Tanks |
| Coolant.....1150 |
| Dip.....992 |
| Rinse.....992 |
| Storage.....27 |
| Wash.....992 |
| Tap & Drill Sets973 |
| Tap Wrenches960, 977 |
| Tape |
| Aisle Marking.....869-870 |
| Aluminum Foil.....1020, 1415 |
| Anti-Skid.....872-873 |
| Bag Sealing.....1436 |
| Barricade.....868 |
| Box Sealing.....1410-1411, 1413, 1429 |
| Conspicuity.....850 |
| Double Sided.....1416 |
| Duct.....1415 |
| Electrical.....1417, 1544 |
| Filament.....1412 |
| First Aid.....729, 744 |
| Flagging.....869 |
| Glow in the Dark.....811, 870, 872-873 |
| Gummed.....1413 |
| Masking.....1414 |
| Measuring.....1276-1279, 1309-1312 |
| Office.....1580 |
| Painter's Masking.....1050 |
| Pavement.....868 |
| Polyethylene Foam.....1416 |
| Pouch.....1449 |
| Sheathing.....1437 |
| Strapping.....1412 |
| Surgical.....729, 744 |

| | | | |
|---|--|---|---|
| Teflon®.....1027-1028, 1416 | TIG Torches1091, 1101, 1103-1105 | Towels | Tube Fittings, Pneumatic1239, 1248 |
| Vinyl.....829, 1416 | TIG Welders1091, 1113 | Cooling.....645-646 | Tubes |
| Tape Dispensers | Tilt Trucks172-173 | Hand.....334, 340-344, 384, 1005, 1583 | Conductor.....1096 |
| Aisle Marking Tape.....868 | Tilters | Paper.....341-344, 346 | Postal.....1434 |
| Box Sealing Tape.....1411, 1429 | Drum.....239-240, 254 | Tracks, Logistic212, 1457 | Tubing, Pneumatic1239 |
| Filament Tape.....1411-1413 | Engine.....208 | Trades Carts169 | Tubing Cutters1374 |
| Gummed Tape.....1411, 1413 | Tilting Vises1295-1296 | Traffic Control | Tumblers, Pail248 |
| Office.....1580 | Time Clocks1575 | Banners.....859 | Tungsten Electrode Grinders1113-1114 |
| Two-Way Tape.....1416 | Timers | Barricade Tape.....868 | Tungsten Electrodes1114 |
| Taper Pin Reamers982 | Digital.....1483 | Barricades.....83, 309, 867, 874 | Turf Edgers368 |
| Tapping Compounds1149 | Mechanical.....378 | Channelizers.....864 | Turntables, Pallet181 |
| Taps | Tip Cleaners1073 | Cones.....862-863 | Turpentine1037 |
| Hand.....956-960, 974-975, 977, 988 | Tip Refacers1073 | Delineators.....863-864 | Tweezers, First Aid729-735, 751 |
| Machine.....976 | Tipppers, Pail245 | Flagging Tape.....869 | Twin Ramps214 |
| Pipe.....960, 973 | Tips | Flags.....858 | Twine, Packaging1450 |
| Tarpaulins379, 1453 | Cutting.....1065, 1070-1072 | Flares.....859 | Two-Way Radios435, 438-439, 441-442 |
| Task Chairs1546, 1551 | Heating.....1072 | Harnesses.....548 | Two-Way Tape Dispensers1416 |
| Task Lights1523, 1529-1530 | Soldering & Brazing.....1064 | Parking Curbs.....861 | |
| Task Seating209, 1134, 1546, 1550-1554 | Tire Bags280 | Pennants.....871 | |
| Task Stools209, 1134, 1550-1554 | Tire Inflator Gauges1224 | Reflectors.....548, 850, 859 | |
| TDG Labels855, 1448 | Tire Pressure Gauges1224 | Speed Bumps.....860 | |
| TDG Placards851-854 | Tire Racks78 | Vests.....545-546 | |
| TDS Meters1490 | Tissue Paper1428 | Traffic Safety Clothing | |
| Technicians' Tools1309-1312, 1378-1379 | Tissues, Lens Cleaning409 | Hat/Toque.....549 | |
| Tees, Pipe Thread1240-1241, 1244 | Toe Guards637 | Jackets.....547-548 | |
| Teflon® Tape1027-1028, 1416 | Toggle Clamps1290-1291 | Overalls.....543 | |
| Telescopic Lights1528 | Toilet Augers1375 | Pants.....548, 551 | |
| Temperature Crayons1142, 1445 | Toilet Auto Flush Adapter350 | Parkas.....547 | |
| Temperature Labels1429 | Toilet Bowl Brushes349 | Rain Jackets.....543 | |
| Temperature Probes1471, 1475, 1488 | Toilet Bowl Cleaners314 | Rain Suits.....543 | |
| Temperature Recorders1476 | Toilet Paper340, 345-346 | Sweatshirts.....547 | |
| Tennis Elbow Braces643 | Toilet Paper Dispensers345-347 | T-Shirts.....547 | |
| Tensabarriers821, 874-880 | Toilet Plungers349 | Vests.....545-547 | |
| Tent Heaters489 | Toilet Seat Cover Dispensers348 | Traffic Signs210, 807, 810, 812, | |
| Tents, Work382, 489, 647 | Toilet Seat Covers348 | 820-821, 851, 857-859 | |
| Test Leads1463 | Tongue & Groove Pliers | Traffic Wands1509 | |
| Test Probes1463 |1309-1312, 1348-1349 | Traffic Cone Bars863 | |
| Test Weights1496 | Tongue Depressors734, 747 | Trailer Jacks212 | |
| Testers | Tool Balancers203 | Trailer Winches195 | |
| Circuit.....1461, 1539 | Tool Holders | Transfer Boxes19 | |
| Hardness.....1479 | ER Collet Chucks.....1269 | Transfer Pumps258, 263, 671 | |
| Insulation.....1467 | Turning Tools.....986 | Transparent Bandages741 | |
| Motor Rotation.....1468 | Tool Kit, Welder's1134 | Trash Cans169, 266-275, 349-350, | |
| Multi-Function.....1462 | Tool Kits, Non-Sparking1386 | 383, 761, 1577 | |
| Phase Rotation.....1468 | Tool Lanyards522-524 | Trays | |
| Shower.....726 | Tool Storage | Boot.....889 | |
| Smoke Alarm.....656 | Aprons.....1391 | Drum.....681, 703, 711, 713 | |
| Voltage.....1462, 1543 | Bags.....1391-1393, 1464 | Filing.....1577 | |
| Tethering, Hard Hats420, 522, 524 | Belts.....1389 | Paint.....1050 | |
| Thermal Cameras1470 | Boxes.....1309-1311, 1393-1394 | Tree Pruners369 | |
| Thermocouple Probes1471 | Cabinets.....103, 1309, 1312, 1395-1400 | Tree Trimmers369 | |
| Thermocouple Thermometers1429, 1471, 1474-1475 | Carts.....123-125, 1395, 1397, 1400 | Trestle Stands209 | |
| Thermo-Hygrometers1474, 1476 | Chests.....1309-1310, 1394-1399, 1402-1403 | Trestle Stepladders129-131 | |
| Thermometer / Hygrometers645, 1472, 1474-1476 | Holders.....1387-1388, 1392 | Triangular Bandages729-735, 747 | |
| Thermometers | Jobsite Boxes.....36, 1394, 1401-1407 | Triangular Files1304-1305 | |
| Bi-Metal.....1473 | Pouches.....523, 1387-1388, 1390-1392 | Tricycles161 | |
| Cooking.....1471, 1473 | Tops, Drum236, 670, 699 | Trigger Sprayers302, 320 | |
| Digital.....1472-1473 | Toque, High Visibility549 | Triggers, MIG Gun1095 | |
| Hygrometers.....645, 1472, 1474-1476 | Torch Handles1065 | Trimmers, Tree369 | |
| Indoor / Outdoor.....1472 | Torch Kits, Welding1064, 1109 | Tripods, Fall Protection491-492 | |
| Infrared.....1469-1470 | Torches | Tri-Wing Bits1344 | |
| Oral.....756 | Air (Gas) Cooled.....1101, 1103-1104 | Trolleys, Beam190, 519 | |
| Stem.....1473 | Butane.....1080, 1083 | Trowels, Drywall1053 | |
| Surface Mount.....1473 | Cutting.....1065 | Truck Mounted Cranes202 | |
| Temperature Crayons.....1142, 1445 | Gas.....1064 | Trucks | |
| Thermocouple.....1429, 1471, 1474-1475 | Gouging.....1087 | Appliance.....150, 1454 | |
| Thermostatic Mixing Valves721 | Propane.....1064 | Box.....166, 172-175 | |
| Thickness Gauges1478-1479 | Water Cooled.....1091, 1103-1105 | Drum.....246-247 | |
| Thimbles194 | Torpedo Levels1281 | Gas Cylinder.....1078 | |
| Thread Repair, Files1307 | Torque Bits1343 | Hand.....144-146, 148-151, 1454, 1554 | |
| Thread Sealants1026 | Torque Meters1329 | Ironer.....303 | |
| Threaded Rod Racks45 | Torque Multipliers1328 | Ladder.....134 | |
| Threadlockers1020, 1027-1028 | Torque Paste1342 | Linen.....303 | |
| Three Square Files1304-1305 | Torque Screwdrivers1329 | Pallet.....144, 182-186 | |
| Thumb Tacks1569 | Torque Wrenches1328 | Panel.....158-160 | |
| Tie-Back Lanyards509-510 | Torx® Bits1343-1344 | Pipe.....160-161 | |
| Tie-Downs683, 1455-1457 | Torx® Screwdrivers1339, 1341 | Platform.....152-158, 160, 165 | |
| Ties, Cable793-794, 1435, 1452 | Towellettes, Benzalkonium729-735, 748 | Stock.....166 | |
| TIG Rods1136-1138, 1140 | Towellettes, Lens Cleaning409, 465, 760 | Tilt.....172-173 | |
| | | Try Squares1280 | |
| | | Tube Brushes945 | |



| |
|--|
| Umbrellas, Welding1118 |
| Undershirts552 |
| Undershirts552 |
| Uppers, Drum250 |
| Upright Protectors54, 85 |
| UPS Systems1542 |
| Urinal Blocks349 |
| Urinal Screens349 |
| Utility Carts76, 166, 168-170 |
| Utility Knives1382, 1440-1442 |
| Utility Scales1492-1494 |



| |
|--|
| Vacuum Cups196-197 |
| Vacuums |
| Accessories..... |
|352-353, 357-359, 361, 688, 1225 |
| Back Pack.....357 |
| Portable.....358 |
| Upright.....360 |
| Wet / Dry.....352-357, 360-361, 688 |
| Valves |
| Adjusting.....1232 |
| Ball.....1231 |
| Butterfly.....1231 |
| Drum.....252 |
| Gate.....252 |
| Safety.....1232, 1257 |
| Water Mixing.....721 |
| Van and Truck Equipment1407 |
| Vane Anemometers1486 |
| Vapor Barrier1437 |
| Vehicle Brushes292 |
| Vents, Drum251 |
| Vertical Life Lines517, 520 |
| Vertical Sheet Rack53 |
| Vests |
| Cooling.....646-647 |
| Reflective.....545-546 |
| Traffic Control.....545-546 |
| Winter.....552 |
| Vibration Isolation |
| Anti-Vibration Pads.....1272 |
| Cupmounts.....1272 |
| Isolators.....1272 |
| Leveling Mounts.....1272 |
| Vibration Meters1484 |
| Vinyl Tape829, 1416 |
| Vise Grips1352 |
| Vises |
| Angle.....1295 |
| Bench.....1293-1294 |
| Drill Press.....1295-1296 |
| Machine.....1295 |
| Tilting.....1295-1296 |
| Visors410-413, 557 |
| Voltage Testers1462, 1543 |

-W-

| | |
|---|----------------------------|
| Wagons | 154, 157, 370 |
| Waiter's / Parade Gloves | 625 |
| Walkie-Talkies | 435, 438-439, 441-442 |
| Walkramps | 214 |
| Wall Barrier, Temporary | 1054 |
| Wall Clocks | 1575 |
| Wall Heaters | 1504 |
| Wall Mounted Fans | 1497-1499 |
| Wall Plates, Crowd Control | 875, 877 |
| Wallet Cards, WHMIS | 846 |
| Wands, Marking | 1038-1040 |
| Warmers, Hand | 629 |
| Warning Lights | 222-223, 863, 866 |
| Warning Systems, Horns | 221 |
| Wash Tanks | 992 |
| Washroom Cleaners | |
| Disinfectants..... | 313-314, 318, 759-760 |
| Toilet Bowl..... | 314 |
| Urinal..... | 349 |
| Washroom Products | |
| Air Fresheners..... | 314, 321-322 |
| Changing Tables..... | 348 |
| Clothes Hooks..... | 350 |
| Drain Augers..... | 1375 |
| Facial Tissue..... | 344 |
| Faucets..... | 350 |
| Grab Bar..... | 350 |
| Hand Dryers..... | 351 |
| Mirrors..... | 350 |
| Paper Towel Dispensers..... | 340-343, 1583 |
| Paper Towels..... | 341-344, 346 |
| Shelves..... | 350 |
| Toilet Augers..... | 1375 |
| Toilet Auto Flush Adapter..... | 350 |
| Toilet Paper..... | 340, 345-346 |
| Toilet Paper Dispensers..... | 345-347 |
| Toilet Plungers..... | 349 |
| Toilet Seat Cover Dispensers..... | 348 |
| Toilet Seat Covers..... | 348 |
| Urinal Screens..... | 349 |
| Washroom Sign | 813 |
| Waste Container Caddy | 266 |
| Waste Container Dollies | 266, 271, 276-277 |
| Wastebaskets | 169, 267-272, 383, 1577 |
| Water Brooms | 377 |
| Water Cooled Torches | 1091, 1103-1105 |
| Water Coolers | 650 |
| Water Filters | 1585-1586 |
| Water Fountains | 1585-1586 |
| Water Heater, Eyewash | 721 |
| Water Hoses, Welding | 1110 |
| Water Preservatives | 722-723, 725 |
| WD-40® | 1004, 1012-1013 |
| Wedge, Non-Sparking | 1381 |
| Weighting Scales | 1491-1492 |
| Weights, Test | 1496 |
| Welder's Tool Kit | 1134 |
| Welding Clothing | |
| Aprons..... | 1132 |
| Beanies..... | 1125, 1133 |
| Bibs..... | 1132 |
| Chaps..... | 1132 |
| Jackets..... | 1132 |
| Sleeves..... | 1132 |
| Spats..... | 1132 |
| Welding Equipment | |
| ADF Filters..... | 1121-1122, 1124-1126, 1128 |
| Burning Guides..... | 1117 |
| Butane Torches..... | 1080, 1083 |
| Carts..... | 1078 |
| Chest Protectors..... | 1125 |
| Chipping Hammers..... | 1087-1088 |
| Connectors..... | 1084-1085 |
| Cutting Tips..... | 1065, 1070-1072 |
| Cutting Torches..... | 1065 |
| Electrode Holders..... | 1084 |

| | |
|----------------------------------|---------------------------------|
| Electrode Ovens..... | 1089 |
| Filter Plates..... | 1126, 1128 |
| Flint Lighters..... | 1073 |
| Flowmeters..... | 1068 |
| Fume Filters..... | 1058-1059 |
| Gas Cylinder Wrenches..... | 1073 |
| Gas Torches..... | 1064 |
| Gels..... | 1145 |
| Gouging Torches..... | 1087 |
| Hand Shields..... | 1123 |
| Heating Tips..... | 1072 |
| Helmets..... | 481, 1121-1127 |
| Magnifier Plates..... | 1126, 1128 |
| MIG Guns..... | 1094-1098 |
| MIG Pliers..... | 1088 |
| MIG Welders..... | 1092-1093 |
| Neck Protectors..... | 1125 |
| Nozzle Reamers..... | 1088 |
| Outfits..... | 1062-1064 |
| Plasma Cutters..... | 1069, 1090 |
| Propane Torches..... | 1064 |
| Quick-Connects..... | 1074 |
| Racks..... | 1078 |
| Reels..... | 1076 |
| Regulator/Flowmeters..... | 1068 |
| Regulators..... | 1064, 1066-1069 |
| Respirators..... | 450 |
| Screens..... | 1118-1119 |
| Soldering & Brazing Tips..... | 1064 |
| Soldering Guns..... | 1080-1082 |
| Soldering Irons..... | 1080-1082 |
| Soldering Stations..... | 1082 |
| TIG Torches..... | 1091, 1101, 1103-1110 |
| TIG Welders..... | 1091, 1113 |
| Tip Cleaners..... | 1073 |
| Tip Refacers..... | 1073 |
| Torch Handles..... | 1065 |
| Torch Kits..... | 1064, 1109 |
| Tungsten Electrode Grinders..... | 1113-1114 |
| Umbrellas..... | 1118 |
| Weld Fillet Gauges..... | 1073 |
| Welding Harnesses | 496, 500 |
| Welding Lanyards | 510 |
| Welding Supplies | |
| Arrestors..... | 1074 |
| Blankets..... | 1118 |
| Brazing Alloys..... | 1139 |
| Cable Lugs..... | 1085 |
| Cable Protectors..... | 1110 |
| Cables..... | 1085 |
| Developers..... | 1020, 1144 |
| Fault Detectors..... | 1012, 1020, 1144, 1148 |
| Flints..... | 1073 |
| Flux..... | 1141, 1145 |
| Gouging Electrodes..... | 1087 |
| Ground Clamps..... | 1086 |
| Hose Fittings..... | 1074 |
| Hoses..... | 1068, 1075, 1110 |
| Matting..... | 904, 1119 |
| MIG Wire..... | 1135, 1137-1138 |
| Pads..... | 1118 |
| Rod / Electrode Containers..... | 1089, 1134 |
| Solder..... | 1140 |
| Stick Electrodes..... | 1136-1137, 1139 |
| TIG Rods..... | 1136-1138, 1140 |
| Tungsten Electrodes..... | 1114 |
| Weld-On Hinges | 1088 |
| Wet Mops | 292-295, 304-306 |
| Wheel Brushes | 941-944, 1271 |
| Wheel Chair | 758 |
| Wheel Chocks | 210-211 |
| Wheel Dollies | 177, 208 |
| Wheel Locks | 782 |
| Wheel Risers | 215 |
| Wheelbarrows | 172, 370 |
| Wheels | 144-145, 148, 154, 232-233, 246 |
| Buffing..... | 937 |
| Crimped Filament..... | 912-913 |
| Cut & Polish..... | 938 |
| Cut-Off..... | 912-916 |
| Deburring..... | 936, 938, 1271 |

| | |
|---|--|
| Finishing..... | 938 |
| Flap..... | 919-920, 937 |
| Grinding..... | 912-917, 1271 |
| Measuring..... | 1278, 1482, 1484 |
| Whips | |
| Hose..... | 1250 |
| Safety..... | 856 |
| White Glue | 1029 |
| White Lithium Greases | 1018 |
| White Lithium Lubricants | 1018 |
| Whiteboard Dry Erase Wipes | 1569 |
| Whiteboard Markers | 823, 1569 |
| Whiteboards | 1569 |
| Whitewash Brushes | 292 |
| WHMIS | |
| Information Charts..... | 847 |
| Labels..... | 846 |
| Pictograms..... | 845-846 |
| Posters..... | 847 |
| Wallet Cards..... | 846 |
| Winches | |
| Hand..... | 195 |
| Personal..... | 492 |
| Windex® | 315 |
| Window Brushes | 292 |
| Window Washers | 299 |
| Windshield De-Icer | 1015 |
| Windssocks | 871 |
| Winter Boots | 635-636 |
| Winter Clothing | |
| Coats..... | 552 |
| Jackets..... | 552 |
| Parkas..... | 552, 555 |
| Vests..... | 552 |
| Winter Lined Gloves | 549, 571, 593, 604-605, 609, 611, 613-618, 626 |
| Winter Liners | 418, 553 |
| Wipes | 316, 318, 332, 334, 336-339, 384, 465, 759-760, 1054 |
| Dry Erase Whiteboard..... | 1569 |
| Wipes Dispensers | 334, 336, 338-340 |
| Wire, MIG | 1135, 1137-1138 |
| Wire Basket Stretchers | 755 |
| Wire Cleaner | 1143 |
| Wire Connectors | 1543 |
| Wire Measurers | 1484 |
| Wire Mesh Bins | 4 |
| Wire Pulling Lubricants | 1012, 1543 |
| Wire Spool Carts | 167 |
| Wire Strippers | 1351 |
| Wire Stripping Pliers | 1377 |
| Wires, Bonding & Grounding | 252-253, 665 |
| Wood Fillers | 1022 |
| Wood Glue | 1029 |
| Woodworking Chisels | 1367 |
| Woodworking Machines, Bandsaws | 1178 |
| Work Boots | 632-633 |
| Work Clothing | |
| Aprons..... | 530-531 |
| Balaclavas..... | 553 |
| Coveralls..... | 550, 554 |
| Hard Hat Liners..... | 418, 553 |
| Lab Coats..... | 550 |
| Pants..... | 550, 552 |
| Shirts..... | 550 |
| Shop Coats..... | 550 |
| Sweatbands..... | 420, 1133 |
| Undergarments..... | 552 |
| Work Lights | 1162, 1520, 1525-1528, 1530 |
| Work Platforms | 135-136, 906 |
| Work Positioners | 181 |
| Work Stands | 209, 225 |
| Work Tables | 120, 1556, 1561 |
| Work Tents | 382, 489, 647 |
| Workbenches | 103, 112-123, 125, 1432 |
| Accessories..... | 118-119 |
| Folding..... | 121 |
| Workstations | 118-119 |
| Accessories..... | 118-119 |
| Computer..... | 1559-1560 |
| Mail..... | 1566 |

| | |
|--------------------------------|----------------------------------|
| Office..... | 1567 |
| Open Wire..... | 118 |
| Packaging..... | 1433 |
| Service Benches..... | 123-125 |
| Shipping..... | 1433 |
| Shop..... | 102, 126 |
| Work Tables..... | 120, 1556, 1561 |
| Workbenches..... | 103, 112-123, 125, 1432 |
| Worm Gear Winches | 195 |
| Wound Closures | 742, 745 |
| Wrap | |
| Bubble..... | 1427 |
| Shrink..... | 1426 |
| Stretch..... | 1424-1426 |
| Wraps, Cooling | 645, 647 |
| Wrecking Bars | 1366 |
| Wrenches | |
| Adjustable..... | 1309-1312, 1330, 1332 |
| Angle..... | 1335 |
| Box..... | 1331, 1336 |
| Bung..... | 250 |
| Chain..... | 1372 |
| Combination..... | 1309-1310, 1312, 1331-1334, 1337 |
| Compound Leverage..... | 1372 |
| Drum..... | 250 |
| End..... | 1373 |
| Flare Nut..... | 1335-1336 |
| Flex Head..... | 1334-1335 |
| Gas Cylinder..... | 1073 |
| Gear..... | 1333-1334, 1337 |
| Hex..... | 1372, 1378 |
| Impact..... | 1159-1160, 1181 |
| Impact - Air..... | 1205, 1208, 1210, 1214, 1222 |
| Non-Sparking..... | 1384-1386 |
| Offset..... | 1373 |
| Open End..... | 1335 |
| Pipe..... | 1309, 1372-1373, 1378 |
| Pump..... | 1335 |
| Ratchet - Air..... | 1206, 1210 |
| Ratcheting..... | 1333-1334 |
| Spanner..... | 1330 |
| Spud..... | 1372 |
| Straight..... | 1373 |
| Strap..... | 1372 |
| Striking Face..... | 1331 |
| Structural..... | 1330 |
| Tap..... | 960, 977 |
| Torque..... | 1328 |
| Wringers | 294, 306-307 |
| Wrist Supports | 643-644, 746 |

-Y-

| | |
|----------------------|------|
| Y Connections | |
| Hose..... | 1074 |