



INSTRUMENTS & ELECTRICAL PRODUCTS



Multimeters & Voltage Tester	1460 - 1463
Equipment Cases	1464 - 1465
Amperage, Capacitance, Phase & Earth Ground Testers ..	1466 - 1468
Infrared Thermometers	1469 - 1470
Thermometers.....	1471 - 1473
Temperature/Humidity Meters, Loggers & Recorders	1474 - 1476
Moisture Meters	1477
Thickness, Coating & Hardness Meters.....	1478 - 1479
Sound & Light Meters.....	1480 - 1481
Speed, Distance & Length Measurers	1482 - 1483
Vibration & Force Gauges	1484
Inspection Cameras.....	1485
Air Velocity Meters	1486 - 1488
Manometers & Pressure Gauges	1489
Refractometers & pH Meters	1490
Scales.....	1491 - 1496
HVAC	1497 - 1506
Flashlights & Batteries.....	1507 - 1519
Emergency Lights	1520 - 1522
Task Lights & Magnifier	1523 - 1524
Work Lights & Cord Reels	1525 - 1532
Extension Cords & Outlets	1533 - 1542
Electrical Devices & Accessories	1543
Electrical Tapes	1544



MULTIMETERS & VOLTAGE TESTERS

DIGITAL MULTIMETERS

- True RMS AC/DC voltage and current measurements
- 0.05% basic DC accuracy
- 40 000-count resolution
- Measures frequency, capacitance and temperature
- Diode check and continuity test
- Backlit LCD readout with analog bar graph
- 1000 V input protection on all ranges
- 4-20 mA process loop measurements with % readout
- Data hold, Max/Min recording mode
- Peak capture mode
- IP67 dust and waterproof
- EN61010-1 Cat. IV 600 V, Cat. III 1000 V safety rating
- Includes test leads and 9 V battery



SPECIFICATIONS:

AC/DC Voltage Range:	1000 V
Accuracy:	AC: $\pm 1.0\%$; DC: $\pm 0.05\%$
AC/DC Current Range:	10 A
Accuracy:	AC: $\pm 1.5\%$; DC: $\pm 1.0\%$
Resistance Range:	40 M Ω
Accuracy:	$\pm 0.3\%$
Frequency Range:	10 MHz
Accuracy:	$\pm 0.1\%$
Capacitance Range:	40 mF
Accuracy:	$\pm 3.5\%$
Duty Cycle Range:	99.9%
Accuracy:	$\pm 1.2\%$
Temperature Range:	760°C (1400°F)
Accuracy:	$\pm 1.0\%$
Dimensions:	182 x 82 x 55 mm
Weight:	360 g

REED

Model No.	Mfg. No.	Description	Price/Each
XC308	R5010	Digital Multimeter	159.00

TRUE RMS MULTIMETER

- AC and DC voltage and current, resistance, capacitance, frequency and duty cycle measurements
- 10MHz frequency counter
- Temperature measurement capability
- True RMS AC voltage and current measurements
- Min/Max/Avg and Peak hold (>1ms) functions
- Store up to 10 000 recorded events
- Real time clock for automatic time stamping of readings
- Log multiple sessions or log data continuously for over 200 hours
- 50 000-count graphical LCD with backlight displays multiple sets of measurement data simultaneously
- Bluetooth interface
- IP67 rated waterproof



IA981

SPECIFICATIONS:

AC/DC Voltage Range:	50, 500mV, 5, 50, 500, 1000V
Resolution:	0.001, 0.01mV, 0.0001, 0.001, 0.01, 0.1V
Accuracy:	AC: $\pm(0.3\% \text{ rdg.} + 25 \text{ dgt.})$ (50/60Hz); DC: $\pm(0.025\% \text{ rdg.} + 5 \text{ dgt.})$
AC/DC Current Range:	500, 5000 μ A, 50, 500mA, 10A
Resolution:	0.01, 0.1 μ A, 0.001, 0.01mA, 0.001A
Accuracy:	AC: $\pm(0.6\% \text{ rdg.} + 25 \text{ dgt.})$ (50/60Hz); DC: $\pm(0.15\% \text{ rdg.} + 20 \text{ dgt.})$
Resistance Range:	50, 500 Ω , 5, 50, 500k Ω , 5, 50M Ω
Resolution:	0.001, 0.01 Ω , 0.0001, 0.001, 0.01k Ω , 0.01, 0.001M Ω
Accuracy:	$\pm(0.05\% \text{ rdg.} + 10 \text{ dgt.})$
Capacitance Range:	5, 50, 500nF, 5, 50, 500 μ F, 10mF
Resolution:	0.001, 0.01, 0.1nF, 0.001, 0.01, 0.1 μ F, 0.01mF
Accuracy:	$\pm(2\% \text{ rdg.} + 40 \text{ dgt.})$
Frequency Range:	50, 500Hz, 5, 50, 500kHz, 5, 10MHz
Resolution:	0.001, 0.01Hz, 0.0001, 0.001, 0.01kHz, 0.0001, 0.001MHz
Accuracy:	$\pm(0.01\% \text{ rdg.} + 10 \text{ dgt.})$
Temperature Range:	-50 to 1000°C (-58 to 1832°F)
Resolution:	0.1°C (0.1°F)
Accuracy:	$\pm(1.0\% \text{ rdg.} + 2.5^\circ\text{C} (4.5^\circ\text{F}))$

REED

Model No.	Mfg. No.	Description	Price/Each
IA981	R5005	True RMS Multimeter	369.00
IA184	CP-09	AC Current Adapter	59.00
IA182	FC-A15	Safety Alligator Clips	4.00

MULTIMETERS

- Non-contact voltage detector
- AC voltage range: 100 to 600 V
- Auto-ranging multimeter
- AC/DC voltage range: 600 V
- AC/DC current range: 200 mA
- Resistance range: 20 M Ω
- Diode check and continuity test
- Flashlight
- Auto power off
- Double molded housing and test leads
- EN61010-1 Cat. III, 1000 V safety rating
- 0.2 A/500 V resettable fuse protection
- 2000-count LCD



REED

Model No.	Mfg. No.	Description	Price/Each
IA050	ST-118	Voltage Detector/Multimeter	49.00

REED R5006 DIGITAL MULTIMETERS

- Pocket-sized, auto-ranging digital multimeter
- Measures AC/DC voltage and current, resistance, frequency, capacitance and duty cycle
- Diode test and continuity check functions
- Data hold and relative mode
- 4000-count LCD display
- Low battery indicator and auto power-off
- Conforms with IEC61010 Cat. II 600V
- Includes test leads, battery and carrying case



SPECIFICATIONS:

AC Range:	4, 40, 400, 600 V
DC Range:	400 mV, 4, 40, 400, 600V
AC Resolution:	1, 10, 100 mV, 1 V
DC Resolution:	0.1, 1, 10, 100 mV, 1 V
AC/DC Current Range:	400, 4000 μ A, 40, 400 mA
AC/DC Current Resolution:	0.1, 1, 10, 100 μ A
AC/DC Accuracy:	$\pm(2\% \text{ rdg.} + 5 \text{ dgt.})$, $\pm(0.8\% \text{ rdg.} + 1 \text{ dgt.})$
Capacitance Range:	4.000, 40.00, 400.0 nF, 4.000, 40.00, 100 μ F
Resistance Range:	400 Ω , 4, 40, 400 k Ω , 4, 40 M Ω
Frequency Range:	99.9 Hz, 0.999, 9.99, 99.9 kHz

REED

Model No.	Mfg. No.	Description	Price/Each
IB740	R5006	Digital Multimeter	49.00

DIGITAL MULTIMETERS

- 0.5% basic DC accuracy
- 4000-count resolution
- Diode check and continuity test
- Data hold function
- Auto ranging and auto power off
- Double molded plastic housing
- EN61010-1 Cat. III 600 V safety rating
- Includes Type K temperature probe, test leads and 9 V battery

SPECIFICATIONS:

AC/DC Voltage Range:	600 V
Accuracy:	AC: $\pm 1.2\%$; DC: $\pm 0.5\%$
AC/DC Current Range:	10 A
Accuracy:	AC: $\pm 3.0\%$; DC: $\pm 2.5\%$
Resistance Range:	40 M Ω
Accuracy:	$\pm 0.8\%$
Frequency Range:	10 MHz
Accuracy:	$\pm 1.5\%$
Capacitance Range:	200 μ F
Accuracy:	$\pm 3.0\%$
Duty Cycle Range:	99.9%
Accuracy:	$\pm 1.2\%$
Temperature Range:	760°C (1400°F)
Accuracy:	$\pm 3.0\%$
Dimensions:	150 x 70 x 48 mm
Weight:	255 g



REED

Model No.	Mfg. No.	Description	Price/Each
IA406	R5008	Digital Multimeter	79.00

STUD/METAL/AC VOLTAGE DETECTOR

- Stud/metal/AC voltage finder with laser line level
- Select Normal Scan, detect up to 3/4" depth, or Deep Scan, detection up to 1-1/2" depth
- 180° pivoting laser plane with level and plumb vials
- Thumb dial adjustment feet for leveling the laser
- 20' laser line projection onto work surface with 90° squaring
- LED display with continuous live wire detection
- LCD sensing and mode display with target graphics
- Vertical and horizontal mounting holes
- Easy key pad operation
- Ergonomically designed for comfort and grip
- Auto power off
- Laser Type: 650nm Class IIIA diode
- Laser Accuracy: 1/2" at 20 ft.
- Length of Laser Line: up to 20 ft.
- Power Supply: Single 9V battery
- Dimensions: 180 x 67 x 38mm
- Weight: 180g



REED

Model No.	Mfg. No.	Description	Price /Each
IA376	LA-1010	Stud/Metal/AC Voltage Detector	79.00
HX360	C-820	Soft Carrying Case	18.00

AC/DC CLAMP-ON ADAPTERS

- Range: 0 to 200 A AC/DC, 0 to 2000 A AC/DC
- Accuracy: ± 2% up to 200 A, ± 3% up to 1500 A w/ push button zero
- Output: 1 mV per 1 A
- Jaw Opening: 2 1/2" (64 mm)

Model No. IA437
Mfg. No. CA-203
Price/Each \$129.00



REED

AC CURRENT CLAMP-ON ADAPTERS

- Ideal tool to extend the current range for all multimeters
- AC current range: 200 A
- Voltage output of 1 mV/A via standard banana inputs

Model No. IA184
Mfg. No. CP-09
Price/Each \$59.00



REED

AC VOLTAGE DETECTORS

- Detects for the presence of AC voltage without contact
- Signals the presence of voltage with an LED light and audible buzzer
- Built-in flashlight
- Doubly-insulated housing for increased safety
- UL approved
- Cat. III 1000V, Cat. IV 600V safety ratings
- Includes batteries
- AC Voltage Range: 90 to 1000V
- Max. Working Current: 32mA
- Power Supply: 2 "AAA" alkaline batteries

REED



Model No.	Mfg. No.	Description	Price /Each
IA976	R5100	AC Voltage Detector	25.00

REED R5200 OUTLET CIRCUIT TESTERS

- Tests whether the outlet is properly wired
- Can perform the entire array of tests by simply plugging the device into the outlet
- One light shows a voltage difference between hot and neutral slots, another shows a voltage difference between the hot slot and the ground hole, and a third shows a voltage difference between the neutral slot and the ground hole
- Easy to read light pattern chart
- Meets LVD:EN 61010-1:2010, EMC:EN61326-1: 2006, EN61000-3-2:2006+ A2:2009, EN61000-3-3:2008
- Voltage range: 110-125 VAC



REED

Model No.	Mfg. No.	Description	Price /Each
IB741	R5200	Outlet Circuit Testers	12.00

MULTIMETER ACCESSORIES

MODEL HX357

- Enables clamp meter user to measure AC current on a 2-wire or 3-wire power cord to 15 A
- Provides easy and safe measurements of current without the need to cut off the plug and separate the conductors
- Plugging the power connector into the line splitter separates the hot/live conductor from the neutral and ground



HX357

MODEL HX358

- Adapts mini-connector inputs to banana plug inputs
- Can be used with many of the thermocouple probes



HX358

REED

Model No.	Mfg. No.	Description	Price/Each
HX357	AC-006	AC Line Splitter	15.00
HX358	AD-1	Input Adapter	12.00

MULTIMETERS & VOLTAGE TESTERS

MULTIMETER COMBO KIT

- IA406 autoranging digital multimeter with temperature function
- HX394 AC/DC current clamp meter with temperature function
- IA976 non-contact voltage detector with built-in flashlight
- HX358 temperature input adapter with HK953 type K thermocouple wire probe
- HX357 AC line splitter
- IA181 safety test leads
- IA707 fused test leads set
- IA434 carrying case



REED

Model No.	Mfg. No.	Description	Price/Each
IA658	ST-MULTIKIT	Multimeter Combo Kit	376.00

ELECTRICIAN'S COMBO KIT

- XC308 AC/DC TRMS multimeter
- HX358 temperature input adapter with HK953 type K thermocouple wire probe
- IA181 safety test leads
- IA707 fused test leads set
- IA184 AC current adapter
- HX357 AC line splitter
- IA434 carrying case



REED

Model No.	Mfg. No.	Description	Price/Each
IA859	ST-ELECTRICKIT2	Electrician's Combo Kit	272.00

INDUSTRIAL COMBO KITS

- Multimeter and clamp meter combo kit
- XC308 True RMS AC/DC multimeter with temperature function
- HX379 AC clamp meter with temperature function
- IA976 non-contact voltage detector with built-in flashlight
- HX358 temperature input adapter with HK953 thermocouple wire probe
- IA181 safety test leads

Model No. IA536
Mfg. No. ST-INDUSKIT
Price/Each \$317.00

REED



HVAC COMBO KITS

- True RMS multimeter and clamp meter combo kit
- XC308 True RMS AC/DC multimeter with temperature function
- IA195 True RMS AC/DC clamp meter with temperature function
- IA976 non-contact voltage detector with built-in flashlight
- HX358 temperature input adapter with HK953 thermocouple wire probe
- IA181 safety test leads

Model No. IA537
Mfg. No. ST-HVACKIT
Price/Each \$434.00

REED



DMM/IR THERMOMETER COMBO KITS

- Multimeter and infrared thermometer combo kit
- IA406 autoranging digital multimeter with temperature function
- HX243 infrared thermometer with laser sighting
- IA976 non-contact voltage detector with built-in flashlight
- HX358 temperature input adapter with HK953 thermocouple wire probe

Model No. IA539
Mfg. No. ST-TEMPKIT
Price/Each \$236.00

REED



See pages
1377 - 1379
for Insulated
Hand Tools



LEADS, CLIPS & TEST PROBES

MODEL IA171

- ø4 mm safety test leads
- Silicone-insulated
- 100 cm long
- Right angle sheathed banana plug to straight sheathed banana plug
- Set of two, one black and one red
- IA171 to be used in conjunction with items listed below

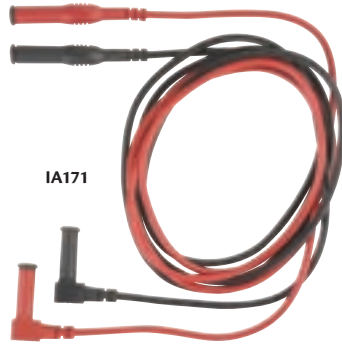

IA171

MODEL IA172

- Safety alligator clips



IA172

MODEL IA173

- Push-on safety test clips with strong jaws
- Insulated, nickel-plated jaws grip objects up to 3/8"
- Blunt grip grabs round screw heads



IA173

MODEL IA174

- Tips include banana-style spring contacts with nickel-plated brass ends
- Ideal for probing banana plug receptacles



IA174

MODEL IA175

- Push-on safety test probes with stainless steel tips
- Rigid with protective caps



MODEL IA176

- Industrial test probes with stainless steel tips



IA176

MODEL IA177

- Safety jaw clips



IA175

MODEL IA178

- Electronic test probes
- Tapered tips for probing electronic components or boards
- Removable guard for IC probing



IA178



REED

Model No.	Mfg. No.	Description	Price/Each
IA171	FC-108	Safety Test Leads	16.00
IA172	FC-A23	Safety Alligator Clips	20.00
IA173	CF-734760	Safety Test Clips	37.00
IA174	FC-105	Safety Test Probes	10.00
IA175	FC-105 A	Safety Test Probes	10.00
IA176	FC-170 A	Industrial Test Probes	16.00
IA177	FC-178 A	Safety Jaw Clips	16.00
IA178	FC-A18	Electronic Test Probes	4.00

BASIC TEST LEADS

MODEL IA181

- Set of two 48" long leads, one black and one red
- Flexible silicone-insulated safety test leads are heat and cold resistant
- Distinctive comfort grip test probes with stainless steel tips



IA181

MODEL IA182

- Slide-on style for test probes
- Jaws open to 8 mm

MODEL IA183

- Same as IA181 with IA182 alligator clips



IA182



IA183

REED

Model No.	Mfg. No.	Description	Price/Each
IA181	TL-88-1	Safety Test Leads	16.00
IA182	FC-A15	Safety Alligator Clips	4.00
IA183	TL-88-A15	Safety Test Lead and Alligator Clips	19.00

FUSED TEST LEAD SETS

- Lead length: 1.4 meters
- Compatible with all instruments that accept standard 4 mm shrouded banana connectors



REED

Model No.	Mfg. No.	Description	Price/Each
IA707	FC-300	Fused Test Lead Set	39.00

TEST LEAD KITS

MODEL IA179

- Safety test lead kit (electrical) includes:
 - IA171 safety test leads
 - IA172 alligator clips
 - IA175 test probes
 - HX360 carrying case



IA179

MODEL IA180

- Deluxe safety test lead kit (electrical) includes:
 - IA181 safety test leads
 - IA171 safety test leads
 - IA182 alligator clips
 - IA172 alligator clips
 - IA178 electronic test probes
 - IA174 test probes
 - IA175 test probes
 - IA176 industrial test probes
 - IA177 safety jaw clips
 - IA173 test clips
 - HX360 carrying case



IA180

REED

Model No.	Mfg. No.	Description	Price/Each
IA179	FC-108G	Safety Test Lead Kit	50.00
IA180	FC-A23G	Deluxe Safety Test Lead Kit	143.00

EQUIPMENT CASES

REED R8888 DELUXE CARRYING CASE

- Black injection molded plastic case with customizable foam inserts
- Simply cut the foam to your specific needs
- Outside dimensions: 13" L x 12" W x 5.8" H (330 mm x 310 mm x 148 mm)

Model No. IB742
Mfg. No. R8888
Price/Each \$69.00



REED R9999 INDUSTRIAL TOOL BAG

- Black and blue polyester bag with a reinforced bottom
- Padded shoulder strap
- Double zipper and mesh pockets
- Outside dimensions: 15.8" L x 7.8" W x 11.8" H (400 mm x 200 mm x 300 mm)

Model No. IB743
Mfg. No. R9999
Price/Each \$49.00



TRADESMAN PRO™ ELECTRICIAN'S BACKPACK ORGANIZER

- 39 pockets for tons of tool storage
- Orange interior for easy tool visibility
- Wide opening fits power drills, meters, flashlights etc.
- Tough, durable bottom protects from harsh elements
- Large front pocket easily fits cables, small parts and tools
- 1680D ballistic weave for durability
- Dimensions: 14" L x 7" W x 18" H

Model No. TYO472
Mfg. No. 55421BP-14
Price/Each \$165.00



CARRYING CASES

PROTECT & STORE YOUR MULTIMETER & ACCESSORIES IN A CARRYING CASE



HX360



HN416



IA434



HN413



Model No	Mfg. No.	Outside Dimensions				Price /Each	
		L"	x	W"	x		D"
IA434	C-833R	11	x	9	x	2	22.00
HX360	C-820	8	x	5	x	2	18.00
HN416	CA-05 A	9	x	4	x	2	19.00
HN413	CA-52 A	7	x	3	x	2	15.00

See pages 1387 - 1393 for more Tool Pouches & Bags





PELICAN PROTECTOR EQUIPMENT CASES

Light, strong, watertight and airtight for the ultimate protection. Constructed of copolymer and polypropylene. Features a 1/4" neoprene O-ring seal and a purge valve. Supplied complete with pre-scored pick & pluck foam or padded dividers (no cutting required). Custom foam insert fabricated on special order. Also includes ABS locking flanges, massive multiple latches and a comfortable molded grip handle.

Note: Models HA597 and HA603 supplied with solid foam only.

- Other colours available for Mfg. No. 1700 to 1750 are desert tan and green
- Other colours available for Mfg. No. 1200 to 1600 are silver, desert tan and green



FEATURES:

O-Ring Seal: Exclusive 1/4" neoprene O-ring guarantees a perfect seal. Neither dust nor water can penetrate this barrier to damage your equipment. These rings are easily replaced if damaged.



Purge Valve: All cases are absolutely airtight. Exclusive built-in O-ring sealed pressure purge valve allows for quick equalization after changes in temperature or altitude.

MODEL NO. HA292

Outside Dimensions:
10 5/8" L x 9 11/16" W x 4 7/8" D
Inside Dimensions:
9 1/4" L x 7 1/8" W x 4 1/8" D
Fold-down handle.
Weight: 2.87 lbs.

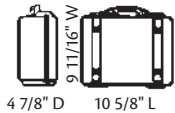

MODEL NO. HA419

Outside Dimensions:
10 5/8" L x 9 11/16" W x 6 7/8" D
Inside Dimensions:
9 1/8" L x 7" W x 6 1/8" D
Fold-down handle.
Weight: 3.53 lbs.

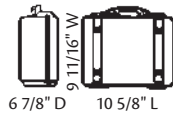

MODEL NO. HA450

Outside Dimensions:
13 3/8" L x 11 5/8" W x 6" D
Inside Dimensions:
11 13/16" L x 8 7/8" W x 5 3/16" D
Fold-down handle.
Integral personalised nameplate.
Weight: 4.41 lbs.

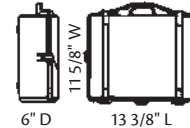

MODEL NO. HA501

Outside Dimensions:
18 1/2" L x 14 1/16" W x 6 15/16" D
Inside Dimensions:
16 3/4" L x 11 3/16" W x 6 1/8" D
Fold-down handle.
Integral personalised nameplate.
Weight: 7.05 lbs.

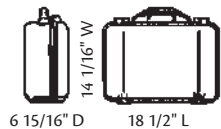

MODEL NO. HM576

Outside Dimensions:
19.78" L x 15.77" W x 7.41" D
Inside Dimensions:
18.06" L x 12.89" W x 6.72" D
Fold-down handle.
Weight: 9.35 lbs.

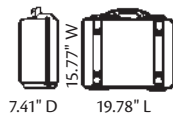

MODEL NO. HA510

Outside Dimensions:
20 5/8" L x 16 7/8" W x 8 1/8" D
Inside Dimensions:
18 7/16" L x 14" W x 7 5/8" D
Fold-down handle.
Integral personalised nameplate.
Weight: 11.9 lbs.

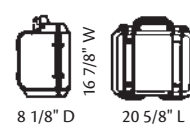

MODEL NO. HA536

Outside Dimensions:
24 1/4" L x 19 7/16" W x 8 11/16" D
Inside Dimensions:
21 7/16" L x 16 1/2" W x 7 7/8" D
Fold-down handle.
Integral personalised nameplate.
Weight: 14.11 lbs.

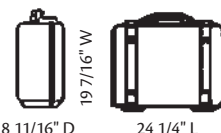

MODEL NO. HA597

Outside Dimensions:
38 1/8" L x 16" W x 6 1/8" D
Inside Dimensions:
35 3/4" L x 13 1/2" W x 5 1/4" D
Fold-down handle.
Weight: 16.98 lbs.

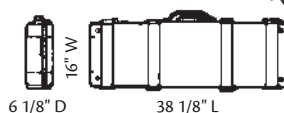

MODEL NO. HA603

Outside Dimensions: 53" L x 16" W x 6 1/8" D
Inside Dimensions: 50 1/2" L x 13 1/2" W x 5 1/4" D
Fold-down handle.
Weight: 25.57 lbs.

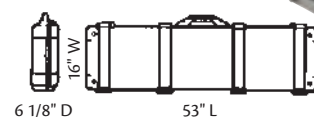

PROTECTIVE CASES

Black Model No.	Orange Model No.	Mfg. No.	Description	Price /Each
HA292	HA293	1200	1200 Case	92.40
HA419	HA420	1300	1300 Case	109.00
HA450	HA451	1400	1400 Case	168.00
HA501	HA502	1500	1500 Case	252.00
HM576	-	1520	1520 Case	274.00
HA510	HA511	1550	1550 Case	308.00
HA536	HA537	1600	1600 Case	374.00
HA597	-	1700	1700 Case	439.00
HA603	-	1750	1750 Case	505.00

FOAM INSERTS

Model No.	Mfg. No.	Description	Price/Each
HA296	1201	3 pc. foam insert for HA292, HA293	32.10
HA423	1301	3 pc. foam insert for HA419, HA420	40.00
HA460	1401	3 pc. foam insert for HA450, HA451	53.50
HA503	1501/A	3 pc. foam insert for HA501, HA502	74.60
HA512	1551	4 pc. foam insert for HA510, HA511	117.00
HA538	1601	4 pc. foam insert for HA536, HA537	163.00
HA599	1701	3 pc. foam insert for HA597, HA598	118.00
HA605	1751	4 pc. foam insert for HA603	147.00

CLAMP METERS

AC/DC CLAMP METERS

- True RMS measurements
- 3-3/4 digit LCD with high-speed, 42-segment bar graph
- Max/Min and Data Hold functions
- Peak Hold function
- Frequency measurement
- Diode and continuity test with beeper
- Polarity and overload indications
- Auto or manual ranging
- Auto power-off
- Low battery indication
- Conforms to EN61010 1000V Cat. II, 600V Cat. III
- Includes IA181 test leads, 6AM6X battery and HN416 carrying case
- Accredited calibration available

SPECIFICATIONS:

Current Range:	40A, 400 A, 1000 A AC/DC
Resolution:	0.01 A, 0.1 A, 1 A AC/DC
Accuracy:	AC: $\pm(1.9\% \text{ rdg.} + 5 \text{ dgt.})$; DC: $\pm(2.5\% \text{ rdg.} + 10 \text{ dgt.})$
Voltage Range:	AC: 400 V, 750 V; DC: 400 V, 1000 V
Resolution:	0.1, 1 V AC/DC
Accuracy:	AC: $\pm(1.5\% \text{ rdg.} + 5 \text{ dgt.})$; DC: $\pm(1\% \text{ rdg.} + 2 \text{ dgt.})$
Resistance Range:	400 Ω , 4000 Ω
Resolution:	0.1 Ω , 1 Ω
Accuracy:	$\pm(1\% \text{ rdg.} + 3 \text{ dgt.})$
Frequency Range:	A & V: 4 kHz, 10 kHz
Resolution:	1 Hz, 10 Hz
Accuracy:	A-Hz: $\pm(0.1\% \text{ rdg.} + 1 \text{ dgt.})$ (20 Hz-10k Hz); V-Hz: $\pm(0.1\% \text{ rdg.} + 1 \text{ dgt.})$ (10 Hz-10 kHz)
Continuity Range:	< 100 Ω
Test Current Range:	1.7 mA max.
Power Supply:	Single 9 V battery
Battery Life:	Approx. 100 hours
Jaw Opening:	40 mm
Dimensions:	242 x 66 x 36 mm
Weight:	400 g

HX161



REED

Model No.	Mfg. No.	Description	Price/Each
HX161	RS050	True RMS AC/DC Clamp Meter	289.00
HX357	AC-006	AC Line Splitter	15.00

AC/DC CLAMP METER

- Measures AC and DC voltage and current, resistance, capacitance and frequency as well as temperature with the included type K thermocouple probe
- True RMS AC measurements
- Diode and continuity test with beeper
- 50 000-count digital display with 61-segment analog
- Auto or manual ranging
- Double molded plastic housing
- Conforms to EN61010 600V Cat. III
- Includes test leads, temperature probe, 9 V battery and case
- AC/DC range: 500/1000 A



REED

Model No.	Mfg. No.	Description	Price/Each
IB065	RS040	AC/DC Clamp Meter	229.00

TRUE RMS AC/DC CLAMP METER

- Measures AC/DC current, AC/DC voltage, resistance, capacitance, frequency, duty cycle, and temperature with a type K thermocouple probe
- True RMS AC measurements
- Non-contact AC voltage detector in clamp tip
- Low battery indication and auto power-off
- 50 000 count LCD with backlight
- Conforms to EN61010 Cat. III 600 V
- Jaw opening: 1.2" (30 mm)
- Includes set of test leads, temperature probe, batteries, and soft carrying case



REED

Model No.	Mfg. No.	Description	Price/Each
IB685	RS030	True RMS AC/DC Clamp Meter	229.00

AC/DC CLAMP METERS

- Full function autoranging DMM includes AC/DC voltage and current, resistance, capacitance, frequency, duty cycle, diode and continuity
- Current measurements to 2000 A through the clamp and 240 mA via test leads
- Large 5000 count backlight display for high resolution
- Basic DCV accuracy of 1% with 0.1 mV resolution and current resolution to 0.1 μ A
- 2.36" (60 mm) clamp jaw opening (750 MCM)
- DC current push button zero, relative measurements and Data Hold
- Heavy-duty ABS case with built-in stand and thumb control function switch



SPECIFICATIONS:

DC/AC Current Range (Clamp):	240, 2000 A
DC/AC Current Range (DMM):	240, 2400 μ A, 24, 240 mA
DC/AC Voltage Range:	2.4, 24, 240, 1000 V
Capacitance Range:	25, 250 nF, 2.5, 25 μ F
Resistance Range:	240 Ω , 2.4, 24, 240 k Ω , 2.4, 24 M Ω
Frequency Range:	50, 500 Hz, 5, 50, 100 kHz
Duty Cycle Range:	0.1% to 99.9%

REED

Model No.	Mfg. No.	Description	Price/Each
HN415	CM-9930	AC/DC Clamp-On Meter	249.00

AC/DC CLAMP METER

- Measures AC current, AC and DC voltage, resistance, capacitance, as well as temperature with the included Type K thermocouple probe
- Diode test and continuity check
- 4000-count LCD displays low battery and overrange indications
- UL approved
- Cat. III 600V safety rating
- Includes one set of test leads, one temperature probe, batteries, and a soft carrying case



SPECIFICATIONS:

AC Current Range:	40.00, 400.0 A
Accuracy:	$\pm(2.5\% \text{ rdg.} + 8 \text{ dgt.})$
DC Voltage Range:	400.0 mV, 4.000, 40.00, 400.0, 600.0 V
Accuracy:	$\pm(1.5\% \text{ rdg.} + 2 \text{ dgt.})$
AC Voltage Range:	4.000, 40.00, 400.0, 600.0 V
Accuracy:	$\pm(1.8\% \text{ rdg.} + 8 \text{ dgt.})$
Resistance Range:	400.0 Ω , 4.000, 40.00, 400.0 k Ω , 4.000, 40.00 M Ω
Accuracy:	$\pm(1.5\% \text{ rdg.} + 2 \text{ dgt.})$
Capacitance Range:	40.00, 400.0 nF, 4.000, 40.00, 100.0 μ F
Accuracy:	$\pm(3\% \text{ rdg.} + 5 \text{ dgt.})$
Temperature Range:	-20.0 to 760.0°C (-4.0 to 1400.0°F)
Accuracy:	$\pm(3\% \text{ rdg.} + 5^\circ\text{C}/9^\circ\text{F})$
Jaw Opening:	1.2" (30 mm) maximum
Power Supply:	2 x 1.5V "AAA" batteries
Dimensions:	200 x 66 x 37 mm
Weight:	205 g

REED

Model No.	Mfg. No.	Description	Price/Each
IA982	RS020	AC/DC Clamp Meter	99.00

INSULATION TESTERS

- Test voltage combinations: 250 V, 500 V or 1000 V
- 1 mA test current for MΩ range at rated voltage
- 200 mA test current for continuity range
- Continuity test with beeper
- Large, easy-to-read dual display with backlight
- Data hold switch
- Test button may be locked on for hands-free operation
- Double moulded plastic housing
- Supplied with test leads, batteries and plastic carrying case
- Meets IEC61010-1 Cat. III 1000 V

SPECIFICATIONS:

Insulation resistance tests

Test Voltage: 250 V, 500 V, 1000 V
Measurement Range: 200 MΩ, 2000 MΩ
Accuracy: ± 3.5% rdg. ± 5 dgt.

Resistance tests

Measurement Range: 200 Ω, 2000 Ω
Accuracy: ± 1% rdg. ± 2 dgt.

Voltage tests

Measurement Range: 750 VAC; 1000 VDC
Accuracy: AC: ± 1.2% rdg. ± 10 dgt.
 DC: ± 0.8% rdg. ± 3 dgt.

Continuity tests

Measurement Range: Beeps ≤ 40 Ω
Test Current: ≤ 200 mA

General

Power Supply: 6 x 1.5 V AA batteries
Dimensions: 200 x 92 x 50 mm
Weight: 700 g



REED

Model No.	Mfg. No.	Description	Price/Each
IA194	ST-5500	Insulation Tester	249.00

INSULATION TESTERS

- A compact and easy-to-use insulation and continuity tester that is ideal for more arduous environments
- Three insulation test ranges: 250 V, 500 V, 1000 V
- Continuity range: 3 Ω and 500 Ω
- 200 mA measuring current on continuity testing
- Live circuit warning buzzer and neon lamp
- Automatic discharge of circuit capacitance
- Dust and drip proof construction (designed to IP54)

Model No. IA193
Mfg. No. KEW3132A
Price/Each \$347.00



SEE PAGES 556 - 558 FOR
 ELECTRICAL SAFETY CLOTHING
 & PROTECTION



INSULATION/CONTINUITY TESTERS

- Polarisation Index (PI) and Dielectric Absorption Ratio (DAR) functions as well as test results storage
- Included accessories: Red/black silicone lead set with clips, protective rubber boot
- Designed to meet the safety requirements for use on CAT IV 600 V

Megger



SPECIFICATIONS:

Nominal Test Voltages:

50 V, 100 V, 250 V, 500 V, 1000 V

Insulation Resistance Range:

2 to 200 GΩ
 1 GΩ full scale

Analogue Range:

Short Circuit Current:

2 mA + 0% - 50%

Leakage Current Range:

10 μA to 2000 μA

Leakage Current Accuracy:

10% rdg. ± 3 dgt.

Voltage Display:

3% rdg. ± 3 dgt. ± 0.5% of rated voltage

Polarisation Index (PI):

10 min/1 minute ratio

Dielectric Absorption Ratio (DAR):

60 sec/30 sec ratio

Continuity Range:

0.01 to 99.9 Ω (0 to 100 Ω on analogue scale)

Accuracy:

± 2% rdg. ± 2 dgt. (0 to 100 Ω)

Open Circuit Voltage:

5 V ± 1 V

Test Current:

205 mA (± 5 mA) (0.01 to 9.99 Ω);

20 mA (± 1 mA) (10.0 to 99.9 Ω)

Buzzer:

Variable limit, 1 Ω, 2 Ω, 5 Ω, 10 Ω, 20 Ω

Resistance Range:

0.01 to 1000 kΩ (0 to 1 MΩ on analogue scale)

Accuracy:

± 3% rdg. ± 2 dgt. up to 50 kΩ,

then ± 5% rdg. ± 2 dgt.

Open Circuit Voltage:

5 V ± 1 V

Short Circuit Current:

1.5 mA ± 0.2 mA

Voltage Range:

0 to 600 VDC

Accuracy:

± 2% rdg. ± 2 dgt.

Frequency Range:

40 to 450 Hz

Accuracy:

± 0.5% rdg. ± 1 dgt.

Capacitance Range:

100 pF to 10 μF

Accuracy:

± 5.0% rdg. ± 2 dgt.

Storage Capacity:

>1000 test results

Power Supply:

5 x 1.5 V, Alkaline batteries,

NiMH rechargeable cells may be used

Battery Life:

2200 insulation tests with duty cycle of 5 sec

ON /55 sec OFF @ 1000 V into 1 MΩ

Dimensions:

220 x 92 x 50 mm (8.66 x 3.63 x 1.97")

Weight:

590 g (20.73 oz)

Model No.	Mfg. No.	Description	Price/Each
IA811	MIT420	Insulation/Continuity Tester	925.00

INSULATION TESTERS

- Measurements from 500 V to 5000 V and up to 60 GΩ
- Sources up to 1.2 mA current during tests to offset capacitance load
- Dielectric absorption ratio measurements (DAR)
- Polarization index measurement (PI)
- Time set measurement function
- Auto-discharge function and voltage output warning function
- Live circuit warning symbols plus audible warning
- Live circuit detection prevents insulation test if >30 V is detected
- Max/Min, Peak, Relative value and Data Hold functions
- 6000-count digital display with bargraph and backlight
- Meets IEC61010-1 Cat. IV 600 V safety standards
- Includes test leads, batteries and carrying case
- Accredited calibration available

SPECIFICATIONS:

Insulation Resistance

Test Voltages:

500 V, 1000 V, 2500 V, 5000 V DC

Insulation Resistance Range:

0 to 60.0 GΩ

Resistance Test Range:

0.1 to 6000 Ω

Voltage Range:

0.5 to 600.0 V AC/DC



REED

Model No.	Mfg. No.	Description	Price/Each
IA855	R5002	Insulation Tester	995.00

CAPACITANCE, PHASE & EARTH GROUND TESTERS

PHASE ROTATION INDICATORS

WITH OPEN PHASE CHECKER

- Designed to check the presence of an open phase and also the phase sequence with rotating disks and lamps
- Verifies a wide range of 3-phase power sources from 110 V to 600 V
- Colour-coded integrated test leads eliminate the risk of misconnection and meter damage



KYORITSU

Model No.	Mfg. No.	Description	Price/Each
IA185	KEW8031	Phase Rotation Indicator	134.00

CABLE TRACERS

- All components are fully fuse protected and intrinsically safe; and fit into a foam-lined carrying case
- Model R2000 Receiver has two detectors in its tip which are tuned to pick up the electromagnetic signals ('short' mode) or electrostatic signals ('open' mode) generated by other components
- LEDs and sensitivity settings indicate the relative signal strength to allow easy detection of the signal source
- Model S2600 Load Signal Generator, when connected to an energized line, will draw a rapidly fluctuating current pulse from the source, causing the power line to emit an electromagnetic signal which is detected by the R2000 in the 'short' mode
- Model T2200 Transmitter injects a signal into an unenergized conductor. If the conductor is broken (open), no current will flow, so the signal is present as a voltage pulse, which is detected along the conductor's length by the R2000's electrostatic detector ('open' mode)
- Model A2201 Inductive Clamp when clamped around the energized line and plugged into the T2200 will induce a signal onto the downstream (load) side to enable identification of equipment on that circuit
- Includes: Receiver, load signal generator, transmitter, clamp-on transmitter accessory, cordsets and adapter



Model No.	Mfg. No.	Description	Price/Each
HD909	AT-2004	Cable Tracing System	1995.00

SEE PAGES 1377 - 1379 FOR INSULATED HAND TOOLS



LCR/CAPACITANCE METERS

- Measure inductance/capacitance/resistance with secondary parameters including dissipation factor (D), quality factor (Q), phase angle (ϕ), equivalent series/parallel resistance (ESR or Rp)
- Autoranging operation for AC impedance and DE resistance measurement
- Auto LCR smart check and measurement
- Series/Parallel modes
- Ls/Lp/Cp with D/Q/ ϕ /ESR parameters
- Support DCR mode 200 to 200M Ω
- High accuracy with 4 or 5 terminal Kelvin measurement
- Testing frequency is up to 10kHz and output frequency is up to 100kHz
- Includes test leads and batteries
- Accredited calibration available



SPECIFICATIONS:

Inductance Range: 2000.0 μ H/20.000/200.0/2000.0 mH/20.000/200.00/2000.0 H

Capacitance Range: 2000.0 pF/20.000/200.00/2000.0 nF/20.000/200.00/2000 μ F

Resistance Range: 20.000/200.00 Ω /2.0000/20.000/200.00 k Ω /2.0000/20.000/200.0 M Ω

Test Frequencies: 100/120/1k/10k/100k Hz

REED

Model No.	Mfg. No.	Description	Price/Each
IA854	R5001	LCR/Capacitance Meter	295.00

VOLTAGE/CURRENT DATA LOGGERS

- Simultaneously measure 2 True RMS AC voltage inputs OR 2 AC current inputs OR 1 AC voltage and 1 AC current input
- User programmable sample rates from 1 second to 24 hours
- Stores up to 256,000 measurements
- User programmable high/low alarms
- LCD indicates time/date, current readings, Max/Min, Peak hold and whether alarm settings have been exceeded
- Download collected data through USB interface
- Auto power off and battery check
- Includes AC current clamp sensor and voltage sensor, USB cable, software, and battery
- Accredited calibration available



SPECIFICATIONS:

AC Current Range: 10 to 200A

AC Voltage Range: 10 to 600V

REED

Model No.	Mfg. No.	Description	Price/Each
IA856	R5003	AC Voltage/Current Data Logger	389.00

PHASE SEQUENCE TESTERS

- Tests phase orientation of 3-phase power sources
- Indicates phase orientation (clockwise or counter-clockwise) and whether each of the three phases is live
- Also indicates direction of motor rotation
- Determines motor rotation without contact
- Easy to open alligator clips with wide jaws
- Double molded housing
- Cat. III 600V safety rating
- Input Voltage: 40 to 600 VAC
- Operating Frequency: 2 to 400 Hz
- Complete with cables with 3 colour-coded alligator clips, 9V battery and carrying case
- Accredited calibration available



REED

Model No.	Mfg. No.	Description	Price/Each
IA857	R5004	Phase Sequence/Motor Rotation Tester	119.00

INFRARED THERMOMETERS

FOOD SERVICE INFRARED THERMOMETERS

- Contact and non-contact food service thermometer
- Optical Resolution: 12:1 (Distance: Spot size)
- Infrared thermometer features laser sighting
- Accepts any Type K thermocouple probe with mini-connector
- Choice of five different colour faceplates - choose a different colour faceplate for each department or food category
- Large backlit LCD readout
- Max, Min, Diff and Avg. displays
- Programmable Hi/Lo alarms
- Lock feature for continuous monitoring
- Includes holster/case

SPECIFICATIONS:

Range:	-76° to 932°F (-60° to 500°C)
Resolution:	±0.1°F (±0.1°C)
Accuracy:	±2% rdg. or ±2°C, whichever is greater
Response Time:	1 second
Spectral Response:	8 to 14 µm
Emissivity:	Preset at 0.97
Optical Resolution:	12:1 (Distance: Spot size)
Type K Thermocouple Probe Range:	-83° to 1999°F (-64° to 1400°C)
Accuracy:	±1% rdg. or ±1°C, whichever is greater
General Power Supply:	2 x AAA alkaline batteries
Dimensions:	175 x 39 x 72 mm (6.9 x 1.5 x 2.8")
Weight:	179 g



IA432



Model No.	Mfg. No.	Description	Price/Each
IA432	PS200	Food Service Infrared Thermometer	115.00

INFRARED THERMOMETERS

- Precise non-contact temperature measurements
- Temperature Range: -58° to 1832°F (-50° to 1000°C)
- Fahrenheit/Celsius selectable
- Digitally adjustable emissivity from 0.10 to 1.0
- High and low alarm setpoints
- Max, Min and Dif. Avg. temperature displays
- Built-in laser pointer
- Large LCD with backlight and display hold
- Includes: battery and carrying case
- 50:1 distance to spot size ratio
- Accredited calibration available



IA084

REED

Model No.	Mfg. No.	Description	Price/Each
IA084	ST-8839	Infrared Thermometer	329.00

INFRARED THERMOMETERS

- Pocket-sized and easy-to-use - just point, shoot and read
- Unique flat surface and modern housing design
- User selectable °F or °C
- Built in laser pointer identifies target area
- Backlighting illuminates display for taking measurements at night or in areas with low background light levels
- Overrange indicator, auto data hold (when trigger released) and auto shut off
- Fixed 0.95 emissivity covers 90% of surface applications
- 8:1 Distance to Spot size ratio
- Includes: battery and carrying case
- Temperature range: -58° to 932°F (-50° to 500°C)
- Accredited calibration available



IB537

REED

Model No.	Mfg. No.	Description	Price/Each
IB537	R2002	Infrared Thermometer	89.00

INFRARED THERMOMETERS

- Fast and safe way to measure surface temperatures, without contact
- Easy to use - just point, shoot and read
- Temperature Range: 0° to 750°F or -18° to 400°C
- Fahrenheit/Celsius selectable
- Fixed emissivity of 0.95
- 8:1 Distance to Spot Size ratio
- Large LCD with backlight and display hold
- Model HN235 features laser sighting
- Carrying case extra



HN235



Model No.	Mfg. No.	Description	Price/Each
HN235	RAYMT4U	Infrared Thermometer w/ Laser Sighting	159.00
HX034	RAYMTAPK	Soft Pouch w/ Wrist Strap	34.50

INFRARED THERMOMETERS

- Measures surface temperatures of hot, hazardous or hard-to-reach objects without contact
- User selectable °F or °C
- Built-in laser pointer
- Pre-set emissivity of 0.95
- 8:1 Distance to Spot size ratio
- Large LCD with backlight and display hold
- Compact, measures just 3.7" x 2.1" x 1" (94 x 56 x 28mm)
- Temperature Range: -58 to 536°F (-50 to 280°C)
- Accredited calibration available



IA853

REED

Model No.	Mfg. No.	Description	Price/Each
IA853	R2001	Infrared Thermometer	59.00

INFRARED THERMOMETERS

- Two-in-one thermometer combines infrared and K-thermocouple probe temperature measurement
- Infrared thermometer with integral type K thermocouple input
- IR Temperature Range: -58 to 1922°F (-50 to 1050°C)
- T/C Temperature Range: -58 to 2498°F (-50 to 1370°C)
- Built-in laser pointer identifies target area
- Digitally adjustable emissivity from 0.10 to 1.0
- 30:1 distance to spot size ratio
- Automatic emissivity capture
- High and low alarms
- Max, Min, Avg, Diff record
- 20 data points of memory
- Display backlighting
- Auto data hold and auto shut off
- Trigger lock
- Includes: type K thermocouple probe, battery, and carrying case
- Accredited calibration available



IA496

REED

Model No.	Mfg. No.	Description	Price/Each
IA496	R2005	Infrared Thermometer w/ Type K T/C	189.00

INFRARED THERMOMETERS

THERMAL IMAGERS 19 200 PIXELS

- 3.5" colour TFT LCD capacitive touch screen
- High thermal sensitivity (NETD) of <math><0.08\text{mK}</math>
- Built-in laser and white LED flashlight
- Built-in visible light digital camera
- 20X continuous zoom
- Includes thermal imager, 7.5 mm lens, lens cap, micro SD memory card, video output cable, headset, USB cable, hood, tripod stand, shoulder strap, battery, charger, DC power supply, user manual, software CD and hard carrying case
- Accredited calibration available

SPECIFICATIONS:

IR Resolution:	160 x 120 pixels
Field of View:	29.8 x 22.6°
Detector Type:	Uncooled microbolometer
Thermal Sensitivity (NETD):	<math><0.08\text{°C}</math> (80mK)
Image Capture Frequency:	50Hz
Focus:	Manual
Temperature Range:	-4 to 752°F (-20 to 400°C)
Accuracy:	$\pm 3.6\text{°F}$ ($\pm 2\text{°C}$) or $\pm 2\%$ of reading
Storage Medium:	4GB micro SD card
Interface:	USB-mini, audio, composite video (PAL and NTSC), Micro SD slot
Drop Test:	2m
Encapsulation:	IP65
Power Supply:	7.4 V lithium polymer battery
Battery Life:	4 hours
Dimensions:	9.56" x 4.06" x 0.525" (243 x 103 x 160 mm)
Weight:	920 g (32.45 oz)



IA978

REED

Model No.	Mfg. No.	Description	Price/Each
IA978	R2100	Thermal Imager	3995.00
IA983	RL-11	11 mm Replacement Lens	895.00
IA984	RL-22	22 mm Replacement Lens	1095.00
IA985	RL-33	33 mm Replacement Lens	1195.00
IA996	R2100-7.4V	Spare Battery	59.00

REED R2050 THERMAL IMAGING CAMERA

- 2.8" colour 240 x 320 pixel LCD display
- High thermal sensitivity (NETD) of <math><0.1\text{°C}</math> @ +30°C (+86°F) / 100mK
- Built-in laser and white LED flashlight
- Built-in visible light 5 Megapixel digital camera
- 32X continuous digital zoom
- Infrared and visual images, picture-in-picture, as well as visual image with infrared overlay
- Automatic hot/cold spot indicator
- Automatic level/span function
- Video recording with voice annotations
- Set-up Commands: Local adaptation of units, language, date and time formats, information of camera



SPECIFICATIONS:

IR Resolution:	80 x 80 (6400 pixels)
Thermal Sensitivity/NETD:	<math><0.1\text{°C}</math> @ +30°C (+86°F) / 100 mK
Focus Distance:	17"x 17" / 0.5 m
Image Frequency:	50 Hz
Temperature Range:	-20°C to +150°C (-4°F to +302°F); 0°C to +350°C (+32°F to +662°F)
Humidity (Operating & Storage):	10% to 90%
Storage Media:	8GB Micro SD Card

REED

Model No.	Mfg. No.	Description	Price/Each
IB745	R2050	Thermal Imaging Camera	1295.00
IB746	R2050-3.7V	Replacement Battery	30.00

INFRARED VIDEO THERMOMETER

- Dual lasers identify exact measuring spot where they converge
- Optical Resolution: 50:1 (Distance: Spot size)
- Fast 150ms response time
- 2.2" TFT colour LCD and built-in 640 x 480 pixels camera
- Supports image (JPEG) and video (AVI) capture alerts
- Transmit images and videos via USB interface
- 72MB internal memory with MicroSD memory card extension
- Datalogging capabilities with date and time
- Includes type K thermocouple probe, AC adapter, USB adapter, mini-tripod, and hard carrying case

SPECIFICATIONS:

IR Temp. Range:	-58 to 3992°F (-50 to 2200°C)
Spectral Response:	8 to 14 μm
Type K Temp. Range:	-58 to 2498°F (-50 to 1370°C)
Air Temp. Range:	32 to 122°F (0 to 50°C)
Dew Point & Wet Bulb Temp. Range:	32 to 122°F (0 to 50°C)
Humidity Range:	0 to 100% RH



IA977

REED

Model No.	Mfg. No.	Description	Price/Each
IA977	R2020	Infrared Video Thermometer/Datalogger	549.00
0M464	SD-MINI (8GB)	8GB Micro SD Memory Card	17.70

INFRARED TEMPERATURE GUNS

- Detect surface hot-spots and help locate electrical problems with this Milwaukee 12:1 Infrared Temp-Gun
- Boasts a high temperature range for electrical, mechanical, and MRO applications
- Max/Min/Avg/Dif modes
- High/low alert
- Raised over-molding protects lens and screen from direct impact
- Simplified buttons and setup for faster scanning
- Temperature Range: -22-1022°F (-30-550°C)



IB744

Milwaukee

Model No.	Mfg. No.	Description	Price/Each
IB744	2268-20	Infrared Temperature Gun	231.00

REED ST-610B DELUXE THERMOMETER KITS

- Single input thermocouple thermometer designed for field use
- Display maximum reading plus data hold
- Large LCD display with backlight
- User selectable °C, °F or °Kelvin
- User selectable resolution of 0.1 or 1°C (0.1 or 1°F)
- Accuracy: ±(0.5% of reading + 2°F/1°C)
- Resolution: 0.1°F or 1°F (0.1°C or 1°C)
- Temperature Range: -58-2000°F (-50-1300°C)
- Includes: Thermocouple Thermometer, **HN209** Surface Probe, **HN212** Air/Gas Probe, **HN214** General-purpose Probe, and a hard carrying case



REED

Model No.	Mfg. No.	Description	Price/Each
HN250	ST-610DELUXE	Deluxe Thermometer Kit	289.00

TYPE K THERMOCOUPLE PROBES

MODEL HN209 SURFACE PROBES

Ribbon-style surface probe. Maximum Temperature: 400°C.



HN209

MODEL HN210 SPRING-LOADED SURFACE PROBES

Spring loaded probe is ideal for all high temperature surface measuring requirements. Extremely fast response time. Not recommended for use as an immersion probe. Maximum Temperature: 500°C.



HN210

MODEL HN211 RIGHT ANGLE SURFACE PROBES

Unique right angle design allows temperature of hard to reach areas to be taken. Great for monitoring temperature inside pipes, also flat surfaces without keeping hands over heated area. Maximum Temperature: 400°C.



HN211

MODEL HN212 AIR/GAS PROBES

Specifically designed to measure air or gases in heating and cooling units, ovens and engine exhausts. Perforated shield permits fast response while providing exceptional element protection. Maximum Temperature: 800°C.



HN212

MODEL HN213 NEEDLE TIP PROBES

Medium gauge hypodermic needle tip, used to measure softer food stuffs, rubbers and solids. Ideal for use in industrial, laboratory and chemical environments. Maximum Temperature: 800°C.



HN213

MODEL HN214 GENERAL PURPOSE PROBES

Used to measure both air and liquids, but it is best recommended for immersion applications. Excellent for checking temperature of oils, water and non-corrosive fluids. Maximum Temperature: 700°C.



HN214

REED

Model No.	Mfg. No.	Description	Price/Each
HN209	LS-109	Surface Thermocouple Probe	75.00
HN210	LS-139	Spring-loaded Surface Thermocouple Probe	89.00
HN211	LS-104	Right-angle Surface Thermocouple Probe	89.00
HN212	LS-103	Air/Gas Thermocouple Probe	75.00
HN213	LS-134 A	Needle Tip Thermocouple Probe	69.00
HN214	LS-107	General Purpose Thermocouple Probe	75.00

DIGITAL THERMOMETERS

- Temperature Range: -58 to 2000 °F (-50 to 1300 °C)
- User selectable °C or °F
- User selectable 0.1°C or 1°C (0.1°F or 1°F) resolution
- Accuracy to 0.5%
- Display maximum reading plus data hold
- Large LCD display with backlight
- Accept K-type thermocouples
- Includes: 9 V battery and holster

HX381



REED

Model No.	Mfg. No.	Description	Price/Each
HX381	ST-610B	Single Input Thermocouple Thermometer	99.00

BIOS™ FOOD THERMOMETER WITH HACCP CHECK

- The "HACCP CHECK" feature is incorporated in our thermometer temperature to graphically indicate critical temperature zone
- The icons and LED indicators located above the display indicate whether a food product stays in a safe or unsafe HACCP "Danger Zone" temperature
- A Green LED appears with indicating a safe cool or frozen condition below 4°C (40°F) or appears with indicating a safe holding temperature above 60°C (140°F)
- When temperature is between 4°C and 60°C (40°F to 140°F) the red LED with will appear and indicate that the temperature is within the HACCP "Danger Zone"
- Accuracy: +/- 1% of reading or 1°C (1.8°F) whichever is greater
- Auto shut off • Shock resistant
- Splash proof • NSF approved
- Temperature Range: -83.2°F - 1999°F (-64°C to 1400°C)
- Includes: sharp Tip K Type Probe

Model No. IB762
Price/Each \$69.90



IB762

PROBES

Model No.	Description	Use	Temperature Range	Price /Each
IB763	Air Gas Probe	Fridge/Freezer	32°F to 482°F/0°C to 250°C	79.50
IB764	Angle Surface Probe	Grill	-58°F to 752°F/-50°C to 400°C	129.00
IB765	Surface Probe	Grill	-58°F to 752°F/-50°C to 400°C	99.50
IB766	6" Chisel Tip Probe	Food	32°F to 482°F/0°C to 250°C	89.90
IB767	4-1/2" Reduced Tip Probe	Food	-58°F to 482°F/-50°C to 250°C	79.90
IB768	Point Tip Probe	Food	-83.2°F to 932°F/-50°C to 500°C	49.50
IB769	Oven & Dishwasher Probe	Oven & Dishwasher	32°F to 1112°F/0°C to 600°C	49.50



IB763

BIOS Professional

RTD THERMOMETERS

- Platinum resistor temperature sensor requires less temperature compensation than thermocouple units
- Selectable sensor types: Pt-100, Pt-500, Pt-1000 (4 wires)
- 4-digit LCD readout with LED backlight
- °C/°F switchable
- Min/Max/Avg functions
- Relative mode and data hold
- Low battery indication with auto power off
- IP67 waterproof housing
- Includes piercing type temperature probe
- Accredited calibration available

Temperature Range: -148 to 572°F (-100 to 300°C)
Resolution: 0.1°F (0.1°C)
Accuracy: ±0.1% reading +0.8°F (+0.4)
Temp. Coefficient: <18°C & >28°C: 0.01% reading +0.03°C
Power Supply: 3 x 1.5 V AAA alkaline batteries
Battery Life: Approx. 100 hours
Dimensions: 150 x 66 x 31 mm
Weight: 175 g



REED

Model No.	Mfg. No.	Description	Price /Each
IA421	C-370	RTD Thermometer	229.00
IA663	TP-R01	Pt-100 Temperature Probe	99.00
HN416	CA-05A	Soft Carrying Case	19.00

THERMOMETERS

PRE-PROGRAMMED THERMOMETERS/TIMERS

- Pre-programmed cooking temperatures for different meats and tastes
- Select taste setting: Rare to well done
- Displays preset and internal cooking temperatures
- Stainless steel probe with 1 m heat resistant wire
- °C/°F switchable
- Temperature Range: -10° to 200 °C (14° to 392 °F)
- Weight: 6.4 oz



HX158

BIOS
Professional

Model No.	Mfg. No.	Description	Price/Each
HX158	DT100	Thermometer/Timer	27.80

INDOOR/OUTDOOR THERMOMETERS W/CLOCK

- Registers both indoor and outdoor temperatures with Min/Max memory
- 12-hour clock
- Wide temperature range: -50° to 70 °C
- Full 1" high LCD digits
- 10' cable to remote temperature sensor
- Desk mount or wall mount by two sided tape or screws
- Operated by single "AAA" size battery (included)
- Dimensions: 4" x 4" x 3/4"



HA285

BIOS
Professional

Model No.	Mfg. No.	Description	Price/Each
HA285	119	Thermometer w/Clock	39.00

INDOOR/OUTDOOR WIRED THERMOMETERS

- Indoor/outdoor temperature
- Min/max memory
- 3 m/9.8' wired sensor probe
- Time and date
- °C/°F switchable
- Large LCD display
- Temperature trend
- Time and alarm features
- Freeze alarm



IA808

BIOS
Weather

Model No.	Mfg. No.	Description	Price/Each
IA808	313BC	Indoor/Outdoor Wired Thermometer	24.00

INDOOR/OUTDOOR WIRELESS HUMIDEX THERMOMETERS

- Displays humidex and heat index
- Humidex and heat index is a combination of temperature and humidity into one number to reflect perceived temperature
- Heat stress index scale
- Indoor and outdoor temperature
- Outdoor humidity
- Min/max memory
- °C and °F switchable
- Wireless transmission range: 45 m/150'

IA504



BIOS
Weather

Model No.	Mfg. No.	Description	Price/Each
IA504	260BC	Wireless Humidex Thermometer	63.90

INDOOR/OUTDOOR WIRELESS THERMOMETERS

- Indoor and outdoor temperature
- Min/max memory
- °C and °F switchable
- Wireless transmission range: 30 m/100'



IA505

BIOS
Weather

Model No.	Mfg. No.	Description	Price/Each
IA505	261BC	Indoor/Outdoor Wireless Thermometer	36.70

INDOOR THERMOMETERS FOR HUMIDITY & TEMPERATURE

- Indoor temperature and relative humidity
- Min/max memory
- °C and °F switchable



IA506

BIOS
Weather

Model No.	Mfg. No.	Description	Price/Each
IA506	263BC	Thermometer for Humidity & Temperature	21.90

INDOOR HYGROMETERS WITH BIOS COMFORT SCALE

- Bios comfort scale indicates ideal humidity range for home and personal health
- Indoor temperature
- Min/max memory
- °C and °F switchable



IA497

BIOS
Weather

Model No.	Mfg. No.	Description	Price/Each
IA497	258BC	Indoor Hygrometer	29.00

INDOOR OUTDOOR THERMOMETERS W/CLOCK

- Displays indoor and outdoor temperatures and indoor relative humidity
- Multiple remote sensor capability
- Humidity range: 20 to 95% RH
- Indoor temperature range: 0 to 50°C (32 to 122°F)
- Outdoor temperature range: -35 to 60°C (-31 to 140°F)
- Includes indoor monitor and remote temperature sensor
- Power supply: 2 x 1.5 V AA batteries for both monitor and sensor

IA807



BIOS
Weather

Model No.	Mfg. No.	Description	Price/Each
IA807	312BC	Indoor Outdoor Thermometers w/Clock	37.00

VARIABLE ANGLE INDUSTRIAL THERMOMETERS

- V-shape case, molded of GE Valox® polyester, is 9" in length. Heavy glass protected front firmly secured against rattles by spring action
- For 3-1/2" stems only and ranges up to and including 300°F, the stem material is a precision die cast Zamac alloy
- Adjustable case locknut and angle adjusting screw work independently to provide a full 360° positioning of thermometer case and stem
- Adjustable joint completely encloses capillary to prevent tampering and foreign matter for entering instrument
- Tube and capillary are blue spirit filled-magnifying lens "blue reading" tube. Precision made to guarantee accuracy within 1% of scale range. Silicone shock mounted for lasting durability.
- Scale is locked in place and adjusted through top of scale

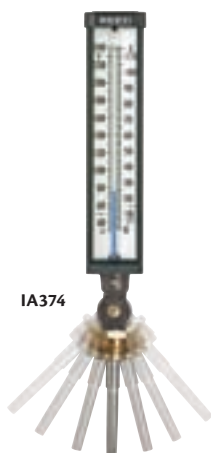

IA374

BI-METAL THERMOMETERS

- All welded stainless steel construction
- Easy external recalibration adjustment
- 3" diameter anti-parallax dial
- Hermetically sealed per ASME B40.3
- Accurate to 1% per ASME B40.3 Grade A
- Over-range protection is 50% up to 500°F
- 1/2" NPT straight connection



IA266

REED

Model No.	Mfg. No.	Description	Price/Each
IA266	T30025-250	0 to 250 °F/-20 to 120 °C, 2-1/2" stem	35.00
IA268	T3004-250	0 to 250 °F/-20 to 120 °C, 4" stem	35.00
IA270	T3006-250	0 to 250 °F/-20 to 120 °C, 6" stem	35.00
IA272	T3009-250	0 to 250 °F/-20 to 120 °C, 9" stem	35.00
IA267	T30025-550	50 to 550 °F/0 to 260 °C, 2-1/2" stem	35.00
IA269	T3004-550	50 to 550 °F/0 to 260 °C, 4" stem	35.00
IA271	T3006-550	50 to 550 °F/0 to 260 °C, 6" stem	35.00

REED

Model No.	Mfg. No.	Description	Price/Each
IA370	9VU35-115	Industrial Thermometer, -40 to 110 °F/-40 to 93 °C	71.00
IA371	9VU35-125	Industrial Thermometer, 0 to 120 °F/-17 to 49 °C	71.00
IA372	9VU35-165	Industrial Thermometer, 0 to 160 °F/-17 to 71 °C	71.00
IA373	9VU35-185	Industrial Thermometer, 30 to 180 °F/-6 to 82 °C	66.00
IA374	9VU35-245	Industrial Thermometer, -40 to 240 °F/0 to 114 °C	71.00
IA375	9VU35-305	Industrial Thermometer, 30 to 300 °F/0 to 149 °C	66.00

STEM THERMOMETERS

- Large, easy-to-read LCD
- Fahrenheit/Celsius switchable
- Range: -40° to 450°F (-40° to 230°C)
- Accuracy: 0° to 230°F: ± 1.0°F; < 0°F: ± 3.6°F; > 230°F: ± 3.6°F
- Resolution: 0.1°F/°C
- 5" stainless steel stem
- Includes one 1.5 V LR44 button battery and protective probe cover

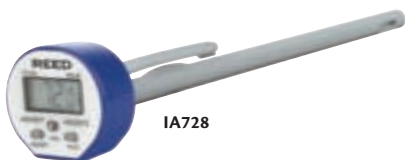

IA728

REED

Model No.	Mfg. No.	Description	Price/Each
IA728	R2000	Digital Stem Thermometer	24.00

STEM THERMOMETERS

- Easy-to-read LCD numerals
- Fahrenheit/Celsius switchable
- Range: -40° to 302°F (-40° to 150°C)
- Accuracy: ± 2°F or ± 1°C
- 5" stainless steel stem
- Immerse stem at least 1" for accurate readings
- Includes one 1.5 V LR44 button battery and protective probe cover



HX502

BIOS Professional

Model No.	Mfg. No.	Description	Price/Each
HX502	DT130	Digital Stem Thermometer	19.60

SURFACE THERMOMETERS

- Specifically designed to be used on horizontal or ferrous non-horizontal surfaces
- Two alnico magnets that act as the thermometer's base and hold it in place on ferrous surfaces
- Bimetallic sensor is a specially processed alloy that is preconditioned and pretested for permanent calibration and maximum stability
- Sensor is located in a draft shield and is in virtual thermal contact with the surface to be measured
- Sensing equilibrium (stability) is reached within three minutes and is accurate to ± 2% of full scale



HB592

REED

Model No.	Mfg. No.	Temperature Range	Divisions	Price/Each
HB592	312FC	0° to 250°F/-20° to 120°C	2°F/1°C	29.00
HB598	314FC	50° to 750°F/10° to 400°C	10°F/5°C	29.00

WATERPROOF DIGITAL STEM THERMOMETER

- Temperature Range: -40° to 450°F (-40° to 230°C)
- Accuracy: ± 0.5°C (± 1°F)
- Fahrenheit/Celsius selectable via push button
- Compact pen-style design
- Stainless steel stem
- On-site calibration possible
- Waterproof construction and maximum temperature memory make this thermometer ideal for verifying dishwasher temperatures
- Includes protective case



IA542

BIOS Professional

Model No.	Mfg. No.	Description	Price/Each
IA542	DT131	Digital Stem Thermometer	23.70

REED R2222 DIGITAL STEM THERMOMETER

- Stainless steel stem thermometer offers a quick response and laboratory accuracy
- Easy to read LCD display
- Fahrenheit/Celsius switchable
- Display updates every 2 seconds
- Max/Min memory records highest and lowest temperatures
- Data hold button lets you freeze a reading
- Auto power off
- Includes: R2222 Digital Stem Thermometer, 1.5 V LR44 Button Battery, Protective Probe Cover
- Resolution: 0.1°C / 0.1°F
- Accuracy: ± 1.5% of reading ± 2°
- Weight: 35g
- Temperature Range: -40-482°F (-40-250°C)



REED

Model No.	Mfg. No.	Description	Price/Each
IB747	R2222	Digital Stem Thermometer	22.00

TEMPERATURE/HUMIDITY METERS

THERMO-HYGROMETERS

COMPACT THERMO-HYGROMETER WITH INTEGRAL PROBE FOR CONVENIENT ONE-HAND OPERATION

- Dual LCD readout shows ambient temperature and relative humidity
- User selectable °F/°C
- Min/Max memory for both functions
- Data hold and relative functions
- Auto power off
- Includes battery
- Humidity Range: 0 to 100% RH
- Temperature Range: -4 to 140°F (-20 to 60°C)



THERMO-HYGROMETERS

- Measures relative humidity as well as temperature with a type J/type K thermocouple thermometer
- Also measures dew point and wet bulb temperatures
- Data hold and Max/Min record
- Real time data logger with integral 4 GB SD memory card (optional)
- RS232 and USB interface
- Temperature is measured in °C or °F



SPECIFICATIONS:

- **Humidity Range:** 5% to 95% RH
- **Type J Temp. Range:** -100° to 1200 °C
- **Type K Temp. Range:** -100° to 1300 °C

REED

Model No.	Mfg. No.	Description	Price/Each
IA793	SD-3007	Thermometer/Hygrometer	359.00
OM463	167130	Memory Card - 4 GB	14.80

REED

Model No.	Mfg. No.	Description	Price/Each
IA441	R6001	Thermo-Hygrometer	159.00

THERMO-HYGROMETERS

- Dual LCD display shows ambient temperature and relative humidity
- Humidity Range: 10% to 95% RH
- Temperature Range: 0° to 50°C/32° to 122°F
- User selectable °C/°F
- Data Hold and Min/Max function
- Compact and lightweight
- Battery included



HX287

REED

Model No.	Mfg. No.	Description	Price/Each
HX287	LM-81HT	Thermometer-Hygrometer	119.00
HN413	CA-52 A	Soft Carrying Case	15.00

TEMP/RH DATA LOGGERS

MONITORS BOTH AMBIENT TEMPERATURE & RELATIVE HUMIDITY

- Stores up to 16 000 temperature and 16 000 humidity readings
- User selectable measurement rate from 2 seconds to 24 hours
- Alarm display if user-defined max/min values are exceeded
- Displays all status information through two LEDs
- Simply plug the logger into the USB port of your computer to begin downloading - no cables or wires are required
- Includes wall mount bracket and Windows® compatible software
- Temperature Range: -40 to 70°C (-40 to 158°F)
- Humidity Range: 0 to 100% RH



Wall mount bracket included

REED

Model No.	Mfg. No.	Description	Price/Each
IA449	R6020	Temperature/Humidity Data Logger	99.00

AIR QUALITY METERS

- Measures CO₂, CO, O₂, humidity and temperature
- Non-dispersive infrared CO₂ sensor
- Galvanic cell CO and O₂ sensors
- Precision capacitance humidity sensor
- Records readings from three probes simultaneously
- Audible alarm setpoint
- Temperature is measured in °C or °F
- Easy to read LCD with backlight
- Data hold and Max/Min record
- Real time data logger with integral 2GB SD memory card (optional)
- RS-232 and USB computer interface
- Auto or manual power off
- **Includes:** humidity probe, CO probe, CO₂ probe, O₂ probe, and hard carrying case

REED

CO₂ Range:	0 to 4000 ppm
Resolution:	1 ppm
Accuracy:	±40 ppm (<1000 ppm), ±5% (>1000 ppm)
CO Range:	0 to 1000 ppm
Resolution:	1 ppm
Accuracy:	±(5% + 2 ppm)
O₂ Range:	0 - 30% O ₂
Resolution:	0.1% O ₂
Accuracy:	±(1% + 0.2% O ₂)
Alarm Threshold:	<18.0% O ₂
Humidity Range:	5 to 95% RH
Resolution:	0.1% RH
Accuracy:	>70%RH: ±(3% rdg + 1%RH); <70%RH: ±3%RH

Temperature Range:	0 to 50.0°C (32 to 122.0°F)
Resolution:	0.1°C/°F
Accuracy:	±0.8°C (±1.5°F)
Dew Point Temp. Range:	-25.3 to 48.9°C (-13.5 to 120.1°F)
Wet Bulb Temp. Range:	-21.6 to 50°C (-6.9 to 122.1°F)
Power Supply:	6 x 1.5V UM3/AA batteries
Dimensions:	177 x 68 x 45 mm; RH Probe: 197 mm L;
CO & O₂ Probe:	150 x 38 x 38 mm; CO ₂ Probe: 190 x 38 x 28 mm
Weight:	350 g

Model No. IA800
Mfg. No. SD-9901
Price/Each \$1195.00



TEMPERATURE/HUMIDITY METERS, LOGGERS & RECORDERS

HEAT STRESS METERS

- Wet Bulb Globe Temperature (WBGT) considers the effects of temperature, humidity and direct or radiant sunlight
- Heat Stress Index measures how hot it feels when humidity is combined with temperature, air movement and radiant heat
- Black Globe Temperature (TG) monitors the effects of direct solar radiation on an exposed surface
- In/Out function displays the WBGT value with or without direct sun exposure
- View individual temperatures or indices in either °F or °C
- User adjustable WBGT threshold with audible alarm if threshold is exceeded
- Built-in RS232 and USB interface
- Tripod mount design for long term monitoring

REED



SPECIFICATIONS:

Air Temp. Range: 0.0 to 50.0°C (32 to 122°F)
Black Globe Temp. Range: 0.0 to 80.0°C (32 to 176°F)
WBGT Temp. Range: 0.0 to 50.0°C (32 to 122°F)
Humidity Range: 0 to 100% RH

Model No.	Mfg. No.	Description	Price/Each
IA639	8778	Heat Stress Meter	219.00
IA447	BS-6	Tripod	69.00
HX515	HR33	33% Humidity Calibration Standard	69.00
HX514	HR75	75% Humidity Calibration Standard	69.00

HEAT STRESS METERS

- Measures indoor and outdoor WBGT (Wet Bulb Globe Temperature), Black Globe (TG) temperature, humidity, wet bulb, dew point and air temperatures
- Adjustable audible WBGT alarm setting
- Real time data logger with integral 4 GB SD memory card (optional)
- RS232 and USB interface
- Temperature is measured in °C or °F

SPECIFICATIONS:

- **Indoor WBGT Range:** 0° to 59 °C
- **Outdoor WBGT Range:** 0° to 56 °C
- **TG Temp. Range:** 0° to 80 °C
- **Air Temp. Range:** 0° to 50 °C
- **Humidity Range:** 5 % to 95 % RH

REED



Model No.	Mfg. No.	Description	Price/Each
IA794	SD-2010	Heat Stress Meter	479.00
OM463	167130	Memory Card - 4 GB	14.80

PSYCHROMETERS

- Simultaneous display with % RH, temperature and dew point or wet bulb or external probe temperature (requires IA108)
- Calculates T1-T2 (Air temp. - External probe temp.) (requires IA108)
- Triple display with backlighting
- Max/Min readings
- Sensor cap closes to protect probe during storage
- Retrieve Max/Min/Avg readings from stored data
- Real time clock
- Humidity Range: 0 to 100% RH
- Dew Point Range: -90° to 122°F (-68° to 50°C)
- Wet Bulb Range: -5° to 122°F (-21° to 50°C)
- Internal Temp. Range: -4° to 122°F (-20° to 50°C)
- External Temp. Range: -4° to 158°F (-20° to 70°C)

REED

IA000



Model No.	Mfg. No.	Description	Price/Each
IA000	8706	Digital Psychrometer	115.00
IA108	87P6	Temperature Probe	25.00
HX515	HR33	33% Humidity Calibration Standard	69.00
HX514	HR75	75% Humidity Calibration Standard	69.00

TEMP/RH DATA LOGGERS

- Records up to 32 700 ambient temperature and relative humidity readings
- User selectable recording intervals from 1 s to 24 h
- Minimum/Maximum function with alarm
- Real-time clock stores data and time
- LCD readout displays current temperature (°F or °C) or humidity reading, min/max reading with date and time
- Download data directly to a PC via USB cable supplied
- Includes data logger, mounting bracket with screws, USB cable, software diskette, security lock and battery
- Temperature Range: -40 to 70°C (-40 to 158°F)
- Humidity Range: 0 to 100% RH

REED



Model No.	Mfg. No.	Description	Price/Each
IA680	R6030	Temperature/RH Data Logger	169.00

TEMPERATURE/RELATIVE HUMIDITY DATA LOGGERS

- Records temperature and relative humidity
- Temperature Range: -40° to 85 °C (-40° to 185 °F)
- Humidity Range: 0 to 100 % RH
- °F or °C selectable
- LCD display
- Logs data for days, weeks or months
- Programmable sampling rate from 1 second to 2 hours
- Three start modes: scheduled, immediate or magnetic
- Records up to 16 000 readings
- Real-time clock stores data and time
- Data is retained in non-volatile memory
- User-defined min/max alarm settings
- Thermistor style sensor

DATA LOGGER KITS

- Kit includes docking station, RS-232 cable and Windows® compatible software
- Enables user to log data, create graphs and program IA100

IA100



REED

Model No.	Mfg. No.	Description	Price/Each
IA100	8829	Temperature/Humidity Data Logger	149.00
IA101	8818	Data Logger Kit	65.00

HEAT STRESS STOP WATCHES

- Measures temperature and humidity, and calculates heat index as well as dew point
- Combines air temperature and relative humidity measurements in an attempt to determine the human-perceived equivalent temperature or "how hot it feels"
- Calendar mode displays day, date and time
- Stopwatch/chronograph mode with 1/100 second resolution
- Fastest/Slowest/Average Lap recall
- 99 lap counter with 30 lap/split memory
- 10 hour countdown timer with audible beeper warning for the last 5 seconds
- 12 or 24 hour clock operation
- Full LCD display with LED backlight
- Silent operation option
- Dual power: solar panel and battery
- 1 ATM water resistant (IPX4 rated)

SPECIFICATIONS:

- **Timing Capacity:** 9 hrs, 59 mins, and 59 secs
- **Accuracy:** ±3 seconds/day
- **Lap Memory:** 30 laps
- **Heat Index Range:** 70 to 122°F (22 to 50°C)
- **Temperature Range:** 23 to 122°F (-5 to 50°C)
- **Humidity Range:** 1 to 99% RH
- **Dimensions:** 2.65 x 3.6 x 0.9" (67.5 x 92 x 23 mm)
- **Weight:** 2.93 oz (83 g)

REED



Model No.	Mfg. No.	Description	Price/Each
IA987	SW700	Heat Index Stop Watch	49.00

TEMPERATURE/HUMIDITY METERS, LOGGERS & RECORDERS

HANGING HYGROMETERS

- Measures relative humidity by comparing readings of wet bulb and dry bulb thermometers
- Accuracy obtained by creating rapid air circulation around bulbs
- Non-mercury red spirit filled thermometers
- Range: -10 to 130°F (-5 to 50°C)
- Plastic moulded case
- Plastic reservoir
- Dimensions: 4" x 10"



DIAL THERMO-HYGROMETERS

- 5" diameter stainless steel dial
- Flange mounting
- Bi-metallic temperature sensor
- Temperature Range: 0 to 120°C, 1°C divisions
- ± 1% temperature accuracy
- Synthetic hair hygrometer
- Humidity Range: 0 to 100% RH, 2% RH divisions
- ± 5% humidity accuracy
- On-site adjustments possible



REED

Model No.	Mfg. No.	Description	Price/Each
IA528	WD-5	Wet Bulb/Dry Bulb Hygrometer	39.00

REED

Model No.	Mfg. No.	Description	Price/Each
IA532	TH600	Dial Thermo-Hygrometer	49.00

TEMPERATURE RECORDERS

- 4-digit display and 3-button keypad make configuration changes fast and easy
- User interface provides access to test and calibration facilities with dual function MODE switch
- Up to 2 pens available, each with configurable spans
- Just one jumper to configure each input port
- 10" chart rotates at user selectable speeds
- NEMA 3 case standard
- **Input Type** **Temp. Range**
- **Type J T/C:** 0/760°C (0/1400°F)
- **Type K T/C:** 0/1360°C (0/2500°F)
- **Type T T/C:** -200/400°C (-330/750°F)
- **Type R T/C:** 200/1650°C (400/3000°F)
- **Type S T/C:** 200/1650°C (400/3000°F)
- **100 Ω Plat. RTD:** -140/400°C (-220/750°F)
- **DC Current:** 0-20 mA, 4-20 mA
- **DC Voltage:** 0-25 mV, 50 mV, 10-50 mV, 0-5 V, 1-5 V



IA096

Partlow

Model No.	Mfg. No.	Description	Price/Each
IA096	51000011	One Pen Temperature Recorder	2069.00
IA097	51100011	Two Pen Temperature Recorder	2649.00

The ultimate!

210-Piece Socket Set, made of chrome vanadium steel for extra strength and durability.



Model TLV362
See page 1313

aurora tools®

MOISTURE METERS

- Ideal for use on any construction site
- Measures the moisture content of sawn timber (also cardboard and paper) and hardened materials like plaster, concrete and mortar
- Measuring Range: Wood: 6 to 44%; Material: 0.2 to 2.0%
- Accuracy: Wood: $\pm 1\%$; Material: $\pm 0.05\%$
- Average adjustment for European wood based on a wood temperature of 20°C
- Impact-proof plastic housing
- Auto power-off
- 8 mm long integrated electrode is replaceable



REED

Model No.	Mfg. No.	Description	Price/Each
IA533	ST-123	Moisture Meter	89.00

MOISTURE DETECTORS

- Pocket-size electronic, non-destructive detector that provides moisture readings instantly and accurately
- Detects moisture beneath the surface being tested by measuring the resistance between two low frequency signals transmitted from conductive pads on the base of the instrument
- Soft conductive electrode pads on the base of the instrument run smoothly over the surface being tested and immediately identify moisture without scratching or penetrating the surface
- Three sensitivity scales:
 - Scale 1:** Timber and wood products
 - Scale 2:** Felt roofing
 - Scale 3:** Plaster and brick



TRAMEX

Model No.	Mfg. No.	Description	Price/Each
HM170	ME-1	Moisture Detector	771.00

PAPER MOISTURE METERS

- Electrical resistance-type moisture meter
- Contact pins mounted on the top of the meter are used for making direct contact with the material
- Various external electrodes are also available for specific applications
- Three scales for testing various paper stock, cores and corrugated (4.3 to 18%); 5 to 40% baled scrap paper; and a 0 to 100% arbitrary scale for obtaining relative moisture indications on other material
- Set point with buzzer to alert you when a pre-selected % moisture content has been reached
- Stores up to 100 readings and displays the average and highest of the stored readings
- Built-in calibration check



DELMHORST

Model No.	Mfg. No.	Description	Price/Each
IA110	P-2000	Paper Moisture Meter	457.00

WOOD MOISTURE METERS

- Three new pin-type wood moisture meters that are ideal for any woodworking application
- Reads surface and core moisture content, giving you key information about a board's uniformity and moisture distribution
- Use the integral electrode pins or attach any Delmhorst electrode to the built-in connector
- model **HM165*** corrects for individual species and temperature and averages up to 100 accumulated readings. Moisture content range: 6 to 40%
- Model **HF940** features 12 LEDs that are great for reading in direct sunlight or dark areas. Moisture content range: 6 to 30%
- Model **HM166*** offers an analog readout in a great new case design. Moisture content range: 6 to 30%



* Available as a package. All packages include meter, deluxe carrying case, 26-ES electrode and extra contact pins.

DELMHORST

Model No.	Mfg. No.	Description	Price/Each
HM165	J-2000	Wood Moisture Meter, Digital Display	457.00
HF940	J-LITE	Wood Moisture Meter, LED	225.00
HM166	J-4	Wood Moisture Meter, Analog Display	372.00

WOOD MOISTURE METERS

- Memory contains eight wood groups with calibrations for approximately 170 species of wood
- Built-in 2-point calibration check
- User settable auto power off with override
- Low battery indication
- Integral contact pins are replaceable, remote moisture electrode pins are not replaceable
- Complete with remote hand-press moisture electrode, temperature probe, protective cap, replacement pins, two AAA batteries, and soft carrying case

REED



SPECIFICATIONS:

Measuring Principle: Electrical resistance
Measuring Range: 6 to 99.9% MC
Accuracy: $\pm 1\%$ MC
Temp. Compensation: -31 to 176°F (-35 to 80°C)
Power Supply: Two AAA batteries
Dimensions: 7 x 1.9 x 2" (180 x 50 x 31 mm)
Weight: 6.1 oz (175 g)
Model No. IA734
Mfg No. ST-129
Price/Each \$179.00

MOISTURE DETECTORS

- Detects moisture content in building materials of all kinds, as well as detects moisture distribution in walls, ceilings and floors
- Non-destructive - moisture sensor runs smoothly over the surface being tested without scratching or penetrating the surface
- Display Hold button
- Max/Min function with alarm indication
- LCD display with backlighting
- Low battery indication with auto power off
- Measuring Range: 0.0 to 100.0% Moisture Content
- Penetration Depth: 20 to 40 mm



REED

Model No.	Mfg. No.	Description	Price/Each
IA681	R6010	Moisture Detector	249.00

COATING THICKNESS GAUGES

COATING THICKNESS GAUGES

- Fast, repeatable measurements
- No calibration required for most applications
- Zero feature for rough or curved surfaces
- Reset feature when no reference is available
- Audible and visible measurement indication
- V-groove in probe for positioning on cylindrical parts
- Strong, wear-resistant ruby-tipped probe
- Mils/microns switchable
- Model **THZ328** measures non-magnetic coatings on steel
- Model **THZ327** measures both non-magnetic coatings on steel and non-conductive coatings on aluminum, brass, etc. automatically recognizes the substrate
- Gauge comes complete with built-in probe, plastic shims, hard shell storage case, "AAA" battery and instructions
- Measuring Range: 0 to 40 mils; 0 to 1000 μm



THZ328

DeFelsko

Model No.	Mfg. No.	Description	Price/Each
THZ328	DFTFERROUS	Coating Thickness Gauge	733.50
THZ327	DFTCOMBO	Coating Thickness Gauge	1042.73

COATING THICKNESS GAUGES

BASIC MODELS

- Larger, easy-to-read LCD with menu-driven user interface
- Flip display with backlight
- Instant automatic gauge set-up
- Average zero and automatic reset features
- Integral constant pressure probe (separate probe models available)
- Mils/microns/mm switchable
- Measuring Range: 0 to 60 mils; 0 to 1500 μm

MEMORY MODELS, ADD

- Storage of 10 000 readings in up to 200 groups
- SSPC PA-2 capability



HC779

DeFelsko

Model No.	Mfg. No.	Description	Price/Each
HC779	F1	Basic Coating Thickness Gauge, Non-magnetic on Ferrous	938.25
HC781	F3	Memory Coating Thickness Gauge, Non-magnetic on Ferrous	1537.72
HC786	N1	Basic Coating Thickness Gauge, Non-conductive on Non-ferrous	1042.73
HC788	N3	Memory Coating Thickness Gauge, Non-conductive on Non-ferrous	1643.26

COATING THICKNESS GAUGES

- Dual technology provides automatic recognition for ferrous (F) and non-ferrous (NF) metal substrates
- Magnetic induction for ferrous metal substrates
- Eddy current measurement for non-ferrous metal substrates
- One or two point calibration
- User-settable high/low alarms
- Min/Max/Average
- Memory stores 400 readings
- Measuring range: 0 to 1250 μm , 0 to 49.21 mils
- Min. curvature radius: F: 1.5 mm; NF: 3 mm
- Min. area Diameter: F: 7 mm; NF: 5 mm
- Min. substrate thickness: F: 0.5 mm; NF: 0.3 mm
- Includes: Two AAA batteries, USB cable, software, calibration iron, calibration aluminum, precision standards and carrying case
- Accredited calibration available



REED

Model No.	Mfg. No.	Description	Price/Each
IA858	ST-156	Coating Thickness Gauge	329.00

COATING THICKNESS GAUGES

- Fast measurement of total coating thickness
- No adjustment required to measure most coatings
- Proven non-destructive ultrasonic technique
- Mils/microns switchable
- Internal memory stores up to 1000 readings
- Easy-to-read, scratch resistant LCD
- Flip display enables right-side-up viewing whether gauge is in your hand or on a table
- Sturdy compact design is solvent, acid, oil, water and dust resistant
- Constant pressure, plastic-tipped probe will not scratch surface
- Comfortable, ergonomic finger grip reduces operator fatigue
- Infrared and RS232 ports
- Gauge comes complete with probe, precision plastic shims, couplant, 2 "AA" batteries, carrying case and instructions
- Measuring Range: 1 to 40 mils; 25 to 1000 μm



THZ326

DeFelsko

Model No.	Mfg. No.	Description	Price/Each
THZ326	200	Coating Thickness Gauge	2842.19

COATING THICKNESS GAUGES

- Permanently calibrated
- Positive visual and audible indicators to designate thickness reading is established
- "V" grooves in probe housing and gauge base to allow correct positioning on cylindrical objects
- GO/NO-GO button can be preset for rapid measurement
- Probe contact and dial rotation all in a one finger operation
- Compact, lightweight, independent of gravity - can be used in any position
- Stable overall design, positive positioning, no pivoting tendencies during measurements
- Can be fully supported or with only front probe area contacting surface
- Functions on a permanent rare-earth cobalt magnet, no battery
- Rugged housing, not affected by mechanical shock, water, acid or solvents
- Highly wear resistant carbide measuring probe

MODEL HF678

- Measuring range: 0 to 80 mils



HF678

DeFelsko

MODEL HF721

- Measuring range: 0 to 8 mils

Model No.	Mfg. No.	Description	Price/Each
HF678	FM	Coating Thickness Gauge	522.42
HF721	GM	Coating Thickness Gauge	522.42

COATING THICKNESS GAUGES

- Measures the thickness of non-magnetic coatings on magnetic or non-magnetic metal substrates
- Automatic probe recognition
- Automatic calibration
- Large, easy-to-read LCD provides exact readings without guessing or errors
- $\mu\text{m}/\text{mil}$ conversion switch
- Includes hard carrying case and batteries
- Probes sold separately
- Measuring Range: 0 to 1000 μm (0 to 40 mil)
- Resolution: 0.1 μm
- Accuracy: ± 1 to 3% or 2 μm , whichever is greater
- Sampling time: 1 second
- Power supply: 4 x 1.5V "AA" batteries



IA673

IA702

IA703

REED

Model No.	Mfg. No.	Description	Price/Each
IA673	CM-8822	Coating Thickness Gauge	459.00
IA702	CM-8822FPROBE	Ferrous Probe	179.00
IA703	CM-8822NFPROBE	Non-Ferrous Probe	179.00

THICKNESS GAUGES

MODEL THZ329

- Simply touch the probe to one side of the material and read its thickness
- Drag the probe along the surface of the material and scan for the thinnest reading
- Backlit display is easy to read, even in dim light
- Bar graph indicates signal strength
- Measuring Range: 0.025 to 19.999" (0.63 to 500 mm)

THZ329



MODEL THZ330

- Alarm mode:** If a measurement falls below minimum specified value, red LED lights and beeper sounds; green LED lights to indicate an acceptable thickness
- Differential mode:** Unit displays positive or negative difference of your minimum specified value
- RS232 data port

MODEL THZ331

- All of the features of model THZ330
- Automatically stores up to 1000 readings with numeric location codes

Model No.	Mfg. No.	Description	Price/Each
THZ329	MX-3	Ultrasonic Thickness Gauge	1894.44
THZ330	MX-5	Ultrasonic Thickness Gauge	2450.64
THZ331	MX-5DL	Datalogging Ultrasonic Thickness Gauge	2772.53

DAKOTA INSTRUMENTS

R9030 HARDNESS TESTERS

- Rebound hardness testing is particularly useful for large, coarse grained materials, forged parts and all types of cast materials
- Measures the velocity of a propelled impact body directly before and after the impact onto the test material's surface
- Capable of automatically converting and displaying measurements into Rockwell (HRC, HRB, HRA), Brinell (HB), Leeb (HL), Vickers (HV) and Shore (HS) hardness values
- Materials that can typically be tested include cast steel, alloy tool steel, stainless steel, aluminum, bronze, copper, cast irons, etc.
- Conversion of measurements to tensile strength (U.T.S.)
- Large capacity memory can store up to 350 groups of information (depending upon impact times) including measurement value, mean value, testing date, impact direction, impact times, material and hardness scale
- Mini USB data interface
- Operates on a rechargeable lithium battery
- 128 x 32 dot matrix LCD with battery life display
- Includes: R9030 Hardness Tester, D Impact Device, Small Supporting Ring, Leeb Test Block, Nylon Brush, Battery Charger, Data Processing Software, Communication Cable
- Hardness Scale: HL, HRC, HRB, HRA, HV, HB, HS
- Measuring Range: HLD: 170 to 96, HRA: 59 to 85m, HRB: 13 to 100, HRC: 20 to 68, HB: 19 to 651, HV: 80 to 967, HS: 30 to 100



REED

Model No.	Mfg. No.	Description	Price/Each
IB748	R9030	Hardness Tester	1595.00

THICKNESS GAUGES

- Exclusive micro-computer LSI circuit and crystal time base offer high accuracy
- Digital display provides exact readings without guessing or errors
- Broad band receiving sensitivity means the meter can read probes of different frequencies
- Auto calibration
- Automatic material calibration
- Selectable metric or imperial
- Measures the thickness of steel, cast iron, aluminum, red copper, zinc, quartz glass, polyethylene, PVC, gray cast iron and nodular cast iron
- Display sound velocity at the touch of a button
- Measuring range: 1.5 to 200 mm in #45 steel
- Velocity range: 500 to 9000 m/s

REED

Model No.	Mfg. No.	Description	Price/Each
HX399	TM-8811	Ultrasonic Thickness Gauge	459.00
IA746	TM-8811probe	Replacement Probe	195.00



DUROMETERS

- Digital durometer for Shore A hardness testing
- Designed to measure the penetration hardness of rubber, elastomer and other rubber like substances such as neoprene, silicone and vinyl
- Pocket-sized model with integrated probe
- Measures maximum value
- Calculates average value
- Push button zero calibration
- Bright, clear, 4-digit, 10 mm high LCD readout
- Meets DIN 53505, ASTM D2240, ISO 7619 and JISK 7215

SPECIFICATIONS:

Measuring range:	0 to 90 HA
Resolution:	0.1 HA
Deviation:	± 1 HA

REED



Model No.	Mfg. No.	Description	Price/Each
IA632	HT-6510A	"A" Scale Durometer	449.00

DUROMETERS

- Models feature a heat-treated, high carbon steel mainspring that is calibrated to meet or exceed ASTM Specification D2240-81
- Special cam permits a scale deflection of 100 points when the indenter is displaced exactly 0.100 inch
- Dial scale is extended over 240 circular degrees, accurate to within ± 1 division
- Threaded mounting knob at the top of each durometer permits permanent test stand emplacement
- Resettable ancillary pointer will register the peak durometer reading against all vibrations met in normal use

MODEL HB548

- "A" Scale durometer measures the indentation hardness of rubber, elastomers, and other rubber-like substances such as neoprene, silicone, vinyl and butyl. It can also be used for soft plastics, felt leather and similar materials

HB548



MODEL HB549

- "D" Scale durometer is designed for hard plastics - polystyrenes, vinyls, Formica, Plexiglas - hard rubbers and phenolic moulded materials

HB538



MODEL HB538

- Foam and sponge rubber durometer measures the hardness of soft materials such as foam rubber, sponge rubber, jells and doughs
- Classifies cellular rubbers of the sponge and foam type as "x-soft", "soft", "medium" and "firm", and then divides these ranges into smaller increments

PTC INSTRUMENTS

Model No.	Mfg. No.	Description	Price/Each
HB548	306L	"A" Scale Durometer	944.58
HB549	307L	"D" Scale Durometer	944.58
HB538	302SL	Sponge Rubber Durometer	1038.51

STEEL HARDNESS TESTERS

- Designed for accurate, rapid in place measurement of the hardness of steel and steel alloys in the range from 20 to 65 on the equivalent Rockwell C Scale
- Unit consists of two major components: calibrated indenter and direct reading microscope
- Hand-held impact indenter drives a 1/16" diameter tungsten carbide ball into the sample being tested
- Resulting indentation diameter is measured with 60X microscope
- Calibrated reticle in the microscope reads C Scale directly with an accuracy of ± 1.5 points
- Illumination system features a MagLite® flashlight with a fiber optic pipe that directs the light to the focus of the microscope
- Flat or curved surfaces of virtually any configuration may be measured
- Particularly useful where the test piece is too large or too heavy to test on bench-type tester



PTC INSTRUMENTS

Model No.	Mfg. No.	Description	Price/Each
HB605	316	Steel Hardness Tester	1366.74



SOUND DETECTORS SD-200



- Compact, lightweight and user friendly
- LED Alert screen provides a quick visual reference of sound levels
- Provides average sound pressure level and delivers a steadier reading in environments such as manufacturing facilities or machine shops where noise levels are often highly variable

Temperature ranges:

- Operating temperature: 32 °F to 104 °F (0 °C to 40 °C)
- Relative humidity: 0%- 90%, non-condensing

Specifications:

- Size: 6.5" x 2.4" x 0.9" / 16.5 cm x 6.1 cm x 2.3 cm
- Weight: 4.4 oz (125 g) approx.
- Battery: Lithium polymer (1000 mAh), rechargeable
- Run-time: 50+ hours without LEDs activated
- Low battery indicator

Measurements:

- Sound Pressure Level (SPL), Average value (LEQ /LAVG), LED Alert (with Hearing Protection icon), Maximum value (MAX), Minimum value (MIN), Run-Time, Overload (OL), and Under-Range (UR)
- Linearity range: 45 to 130 dB (Dynamic Range)
- Weighting: A or C
- Exchange Rate (ER): 3 dB or 5 dB
- LED Alert Levels:
Green LED Flashes when noise measurements are between 80 to 85 dB
Yellow LED Flashes when noise measurements are between 85 to 105 dB
Red LED Flashes when noise measurements are above 105 dB



Model No.	Mfg. No.	Description	Price/Each
IA848	SD-200	Sound Detector	429.00

NOISE INDICATOR BADGES NI-100

- Designed to alert users when noises in an area reach potentially hazardous levels
- Small size and lightweight design make it ideal for workers in a variety of industries
- Clips to clothing using LED light to offer real-time noise detection
- **Red flashing LED:** Indicates noise levels are above 85 dBA and hearing protection may be required
- **Green flashing LED:** Indicates noise levels are below 85 dBA and hearing protection may not be necessary
- Rechargeable lithium polymer battery operates up to 200 hours between charges
- Charging cable not included



Model No.	Mfg. No.	Description	Price/Each
IA849	NI-100	Noise Indicator Badge	53.50

DATALOGGING SOUND LEVEL METERS

- IEC651 Type II
- 32-80, 50-100, 80-130 dB level ranges
- Autoranging from 30 to 130 dB
- Dynamic range of 50 dB
- 0.1 dB resolution
- Frequency range: 31.5 Hz to 8 kHz
- Accuracy of ± 1.5 dB (ref 94 dB @ 1 kHz)
- 32 000 record data logger
- 4-digit backlit display
- Clock and bar graph displays
- Auto power off
- AC and DC output
- Max/Min function
- Includes calibration screwdriver, windscreen, RS232 cable, Windows® datalogging software, battery, manual and carrying case



MODEL HN408

- Wind shield ball for sound level microphones
- Compatible with IA153, HN404, HN405, HX311 and IA154
- Size: 65 mm dia.



Model No.	Mfg. No.	Description	Price/Each
IA153	C-322	Datalogging Sound Level Meter	355.50
HN408	SB-01	Wind Shield Ball	7.00

REED SOUND LEVEL METER/DATA LOGGERS

- Measuring Range: Low: 30 to 90 dB; Med: 50 to 110 dB; High: 70 to 130 dB Auto: 30 to 130 dB
- Dynamic Range: 60 dB • Accuracy: ±1.4 dB • Resolution: 0.1 dB
- Sample Rate: Digital: 0.5 sec. Analog: 50 mS
- Frequency Range: 20 Hz to 8 kHz
- Frequency Weighting: A and C
- Microphone: 1/2" electret condenser
- Power Supply: 4 x AAA batteries
- Meets IEC 61672-1 Class 2 requirements
- Records up to 64 000 datapoints (1 MB)
- 60 dB dynamic space in each range • Real time clock and calendar
- Fast/slow time weighting • Min/Max function • USB Interface
- Analog digital bar graph • Backlit LCD display
- Tripod mount design for long-term monitoring
- Includes windscreen, USB cable, Windows software, batteries and hard carrying case



Model No.	Mfg. No.	Description	Price/Each
IB749	R8080	Sound Level Meter/Data Logger	395.00

SOUND LEVEL METERS

- Measures sound levels in accordance with IEC61672 Class 2 Specifications:
- A/C frequency weighting
- Fast/slow time weighting
- Peak hold, data hold and max./min. record
- Real time data logger with integral 4 GB SD memory card (optional)
- RS232 and USB interface
- Measuring Range: 30 to 80 dB, 50 to 100 dB, 80 to 130 dB



Model No.	Mfg. No.	Description	Price/Each
IA799	SD-4023	Sound Level Meter	395.00
OM463	167130	Memory Card - 4 GB	14.80

SOUND CALIBRATORS

- Two outputs levels 94 dB and 114 dB (at 1 kHz)
- Diecasting aluminum alloy housing case
- Two 9 V batteries
- Size: 50 mm dia. x 82 mm

Model No. IA661
Mfg. No. SC-05
Price/Each \$249.00



SOUND LEVEL METERS

- Dual range measurement (Hi/Lo)
- A and C frequency weighting
- Large, easy-to-read LCD display
- Electret condenser microphone for high accuracy and longterm stability
- AC/DC output signal for use with dataloggers
- Data Hold, Max Hold functions and low battery indication
- Meets IEC651 Type 2 requirements
- Measuring range: Low: 35 to 100 dB; High: 65 to 135 dB (A and C)
- Includes carrying case and battery



REED

Model No.	Mfg. No.	Description	Price/Each
HX387	R8050	Sound Level Meter	195.00

LIGHT METERS

- Designed for one-hand operation and to fit easily into a tool belt or pocket
- Autoranging
- Data Hold and Min/Max functions
- Auto shut-off and zero adjust button
- Over range and low battery indications
- Ranges: 0 to 20 000 lux; 0 to 2000 ftc
- User selectable Lux/Ftc
- Includes battery



REED

Model No.	Mfg. No.	Description	Price/Each
HX288	LM-81LX	Light Meter	109.00

REED ST-1301 LIGHT METERS

- User selectable Lux/Foot-candles
- Max and data hold function
- 3-1/2" digit LCD display
- Over range and low battery indication
- Auto shut off
- Compact and lightweight
- Data logging
- Includes: ST-1301 Light Meter, Battery, Carrying Case
- Measuring range: 0-5000 Fc; 0-50 000 lux
- Resolution: 0.1 lux/Fc
- Sampling time: 1.5 times/second



REED

Model No.	Mfg. No.	Description	Price/Each
HX366	ST-1301	Light Meter	89.00

LIGHT METERS

- Measures ambient light levels as well as temperature with a type J/type K thermocouple thermometer
- Sensor features two filters and meets C.I.E. spectrum Specifications:
- Real time data logger with integral 4 GB SD memory card (optional)
- RS232 and USB interface
- Light levels are measured in ftc or lux
- Temperature is measured in °C or °F
- Light range: 2000, 20 000, 100 000 lux
- Temp. range: J: -100° to 1200 °C; K: -100° to 1300 °C



REED

Model No.	Mfg. No.	Description	Price/Each
IA798	SD-1128	Light Meters	249.00
OM463	167130	Memory Card - 4 GB	14.80

REED YK-10LX LIGHT METERS

- Digital blue filter light meter designed to measure a wide range of lighting types
- Large, 3-digit, 0.5" high, LCD display provides clear readouts even in high ambient light levels
- Zero adjustment screw
- Data logging
- Over range and low battery indication
- Measuring range: 0-20 000 lux
- Resolution: 1, 10 lux
- Accuracy: ±5% of reading
- Sampling time: 2 times/second



REED

Model No.	Mfg. No.	Description	Price/Each
HX319	YK-10LX	Light Meter	119.00

ENVIRONMENTAL METERS

- Measures relative humidity, air velocity, light levels, and temperature with a type J/type K thermocouple thermometer
- Real time data logger with integral 4 GB SD memory card (optional)
- RS232 and USB interface
- Air velocity is measured in m/s, ft/min, km/h, mph or knots
- Light levels are measured in ftc or lux
- Light range: 0 to 20 000 lux
- Humidity range: 5 % to 95 % RH
- Air velocity range: 0.4 to 25.0 m/s
- Temp. range: J: -50° to 1200 °C; K: -50° to 1300 °C



REED

Model No.	Mfg. No.	Description	Price/Each
IA795	SD-9300		295.00

SPEED, DISTANCE & LENGTH MEASURERS

TACHOMETERS

- Dual function unit with both contact and non-contact capabilities
- Supplied with adapters for fpm, rpm and surface speed measurements
- Non-contact function utilizes laser light beam for improved accuracy
- Recalls Max/Min and last values
- Large, easy-to-read display
- Autoranging with 0.05% accuracy
- Includes battery and carrying case
- Measuring Range: Photo: 5 to 99,999 rpm; Contact: 5 to 19,999 rpm; Surface Speed: 0.05 to 1999 mpm



HX386

TACHOMETERS

- Patented design incorporates both a photo and a contact tachometer into one precision instrument
- Ranges: from 0.5 to 20 000 rpm in contact mode; from 5 to 99 999 rpm in photo mode; surface speed from 0.05 to 1999.9 mpm (0.2 to 6560 fpm)
- Linear surface speed measurements are 0.2 to 6560 fpm or 0.05 to 1999.9 mpm
- Automatically holds last reading for five minutes and recalls min. and max. readings
- Characters on the large 5-digit display reverse direction depending on which measurement mode you are in
- Provides accuracy to 0.05% and permits readings to a resolution of 0.1 rpm in either photo or contact mode



HF964

REED

Model No.	Mfg. No.	Description	Price/Each
HF964	K4010	Photo/Contact Tachometer	359.00
IA046	ST-CONE	Replacement Contact Adapter	5.00

REED

Model No.	Mfg. No.	Description	Price/Each
HX386	ST-6236B	Photo/Contact Tachometer	179.00
IA046	ST-CONE	Replacement Contact Adapter	5.00
IA047	ST-WHEEL	Replacement Surface Speed Wheel	20.00
IA740	ST-FUNNEL	Replacement Funnel Tip	11.00
IA741	ST-SHAFT	Replacement Extension Shaft	13.00

R8002 LASER DISTANCE METERS

- Easily measure hard-to-access areas, like high ceilings, with laser targeting
- Instant measurement with one-button operation
- Quick calculation of area (square footage) and volume
- Easy addition and subtraction of measurements
- Pythagoras calculation for determining distance indirectly from two or three other measurements
- Reference point setting function
- Metric or Imperial units of measure
- Display backlight
- Storage of last 10 measurement results
- Measuring Range: -0.16' - 147.6' (-0.05 m - 45 m)
- Accuracy: ≤ 10 m: ± 2.00 mm; >10 m: ± 2 mm ± 0.05 (x distance in metres -10)
- Laser type: Class II, <1 mW, 620 to 690 nm
- Power supply: 2 x AAA 1.5 V batteries



IB750

REED

Model No.	Mfg. No.	Description	Price/Each
IB750	R8002	Laser Distance Meter	139.00

LASER DISTANCE METERS

- One-person distance measuring and estimating tool that measures difficult to reach places
- Laser target pointer
- Auto horizontal distance
- Indirect measurement using Pythagoras
- Angle, slope and pitch measured by placing body of meter on the slope itself or aligning it at the desired angle
- Area and volume calculations
- Addition/subtraction functions
- Min/max distance tracking
- Store/recall up to 20 measurements
- Multi-line display with illumination
- Buzzer indication of reading
- Multifunctional end pieces
- Dust and splash-proof to IP54



REED

SPECIFICATIONS:

Measuring Range	0,05 to 50 m (2" to 164')
Accuracy	± 1.5 mm (± 0.06 ")
Laser	Class 2, 635 nm, <1 mW
Power Supply	2 x 1.5 V AAA batteries
Battery Life	Up to 5000 measurements
Dimensions	110 mm x 45 mm x 27 mm
Weight	135

Model No.	Mfg. No.	Description	Price/Each
IA847	R8001	Laser Distance Meter	195.00

DISTANCE MEASURING WHEELS

- Ideal for road distance measuring applications
- Fitted with a 1 m circumference wheel
- Two measuring modes: Trip and Total
- Accuracy: $\pm 1\%$
- Adds forward, subtracts in reverse
- Metric and imperial measurement
- Measure in meters, yards or feet and inches at the push of a button
- Large LCD display is crystal clear in direct sunlight
- Backlight for low light conditions
- Waterproof for all weather conditions
- Push button reset
- Electronic brake
- Telescopic handle
- Mud scraper
- Minimum 5-year battery life



HC438

TRUMETER

Model No.	Mfg. No.	Description	Price/Each
HC438	5505E	Distance Measuring Wheel	139.00

See pages 1276 - 1278 for Hand Held Tape Measures



SPEED, DISTANCE & LENGTH MEASURERS

TALLY COUNTERS

MODEL HD317 HAND TALLY COUNTERS

- Sturdy 4-figure hand-operated reset counter
- Push button actuator and handy thumb ring for easy operation
- Chrome plated steel case resists damage from perspiration
- Recommended for applications where operator must be mobile, such as checking meeting attendance, taking warehouse inventories, etc.



HD317

MODEL HD339 STAND TALLY COUNTERS

- Sturdy 4-figure hand-operated reset counter
- Special mounting base designed for desk, bench or clipboard mounting
- Heavy gauge steel case and base are chrome plated to resist corrosion
- Recommended for fixed applications such as assembly line parts counting, traffic surveys, etc.



HD339

K4030 STROBOSCOPES

- Freeze the motion and measure the speed of a rotating object, without contact
- Push button that doubles and one that divides in half the flashing and display rate with just one activation
- Coarse and fine adjustment buttons to synchronize flash to exactly the right rate
- Duty cycles from 10 minutes to 2 hours depending on rpm range
- Exclusive one-chip micro-computer LSI circuit and crystal control time-base
- External trigger input
- RS232 serial interface



SPECIFICATIONS:

Flash tube type: Xenon white lamp, 6500°K
Flash duration: Approx. 60 to 1000 μ s
Measuring range: 10 to 10500 rpm
Resolution: 0:1 rpm; 5 to 999.9 rpm; 1 rpm: 1000 to 9999 rpm; 10 rpm: = 10000 rpm
Accuracy: $\pm(0.15\%$ rdg. $+0.2$ rpm) < 1000 rpm; $\pm(0.5\%$ rdg. $+1$ rpm): 1000 to 3300 rpm; $\pm 1\%$ f.s.: 3301 to 10500 rpm

REED

Model No.	Mfg. No.	Description	Price/Each
HD317	7655	Hand Tally Counter	16.00
HD339	8-005-1	Stand Tally Counter	19.00

REED

Model No.	Mfg. No.	Description	Price/Each
HX282	K4030	Stroboscope	495.00

PLASTIC RATCHET COUNTERS

- Reliable, low cost, plastic counters for all purposes
- Operated by stroke (ratchet) drive
- Counts with one 45° adjustable lever movement (spindle on right side)
- 5-figure register with knob reset
- Supplied with connecting spring
- 5-figure reset counter counts machine revolution
- Adds when lever is revolved counter clockwise (spindle on right side)



HA931

TRUMETER

Model No.	Mfg. No.	Description	Price/Each
HA931	2012-5	Right Ratchet Counter, Plastic	19.00

MINI TIMERS

- Easy to use
- Slim design
- Counts up or down to a maximum of 99 minutes, 59 seconds
- Magnetic back
- Pocket size
- Rubberized finish



IA809

BIOS Professional

Model No.	Mfg. No.	Description	Price/Each
IA809	138HC	Mini Timer	5.55

JUMBO DIGITAL TIMERS

- Jumbo LCD display
- Minutes and seconds
- Count down timer
- 30-second beeper alarm
- Magnetic back, built-in clip, retractable stand



HX500

BIOS Professional

Model No.	Mfg. No.	Description	Price/Each
HX500	DT122	Digital Timer	14.00

STOP WATCHES

MODEL IA078

- High contrast digital display with backlight
- Clock, date and alarm functions
- Records real time and split times
- Remembers first 30 laps and their split times (max. 99 laps displayed)
- 1/100th second resolution up to 100 hours
- Shock and water-resistant case



IA078

MODEL IA006

- Large LCD that displays real time and records split times for accurate result
- Clock, date and alarm function
- Water-resistant
- Includes: Batteries and a 48" nylon lanyard which allows you to comfortably hang the stopwatch around your neck



IA006

REED™ SW600 STOPWATCH

- Records real time and split times
- Displays hour, minute, second and day of the week
- High contrast digital display
- 1/100th second resolution
- Alarm and snooze functions
- Shock and water resistant case
- Neck Lanyard & battery included
- Display Type: LCD
- Accuracy: ± 3 seconds/day
- Timing Capacity: 0.41665509259
- Water Resistant: Water Resistant



Model No. IA742
Mfg. No. SW600
Price/Each \$24.00

BIOS Fitness

Model No.	Mfg. No.	Description	Price/Each
IA078	FP603	Digital Stop Watch, w/neck lanyard and battery	32.20
IA006	FP600	Digital Stop Watch, w/neck lanyard and battery	30.10

REED

MEASURERS & FORCE GAUGES

ELECTROMAGNETIC FIELD METERS

- AC & DC magnetic field measurement
- Measurements Range: ± 3000 milliGauss
- Measurements in milliGauss or μT (microTesla)
- Detects magnetic fields as small as 0.1 milliGauss
- N pole/S pole indicator
- Zero adjustment button for relative measurement
- Data hold and max./min. record
- Easy to read LCD with backlight
- Auto or manual power off
- RS232 and USB interface

Model No. IA806
Mfg. No. GU-3001
Price/Each \$695.00

REED



VIBRATION METERS

- Measures vibration levels in machinery
- Unique vibration sensor with magnetic base
- Peak hold, data hold and max./min. record
- Real time data logger with integral 4 GB SD memory card (optional)
- RS232 and USB interface
- Metric or Imperial measurement units
- Acceleration Range: 0.5 to 199.9 m/s²
- Velocity Range: 0.5 to 199.9 mm/s

REED

Model No.	Mfg. No.	Description	Price/Each
IA803	SD-8205	Vibration Meter	895.00
OM463	167130	Memory Card - 4 GB	14.80



DIGITAL FORCE GAUGES

- Provides readings of tension (push) or compression (pull) in kg, lb. oz. and Newton units
- Instantly recalls "Peak Load" (max. load) and average readings
- Microprocessor assures $\pm 0.2\%$ accuracy and fast 0.8 second update time
- 100% Zero/Tare control enables maximum pre-load to be stored in the memory
- Zero Adjust push-button and Peak Hold switch
- Selectable fast/slow response
- Large 5-digit LCD display is reversible to match viewing angle
- Holes on the back of the meter case facilitate test stand mounting
- Battery or AC-line operated (uses 6 x 1.5 V "AA" batteries)
- Auto Power Off minimises power consumption and saves battery life
- Includes separate load cell sensor with 2 hooks and cable and carrying case
- Model IA804: Includes flat head, cone head, chisel head and hook adapters, 120mm extension rod and carrying case, capacity: 20 kg, 44 lbs., 196 N
- Model IA805: Includes separate load cell sensor with 2 hooks and cable and carrying case, capacity: 100 kg, 220 lbs., 980 N



IA804

IA805



HX279

Included case and accessories

REED

Model No.	Mfg. No.	Description	Price/Each
IA804	SD-6020	20-kg Capacity	695.00
IA805	SD-6100	100-kg Capacity	695.00
HX279	FS-1001	Test Stand	1195.00

MEASURING COUNTERS

- Ideal for a wide range of applications on machines where an accurate record of lengths is required
- All units utilize the senior series MKII counters with reset, either totaling or predetermining models
- SR3 has a hinge arrangement, enabling the unit to be mounted in virtually any position
- SR4 comprises one stand, one stay rod 8" in length and one measuring wheel
- SR7 is supplied with 1 stand and 18" long stay rod and two measuring wheels
- Counter can be tilted over to be out of the way when not in use
- Standard measuring wheels are 5/8" wide rubber covered
- 12" circumference wheels are supplied for imperial measurement and 1/3 meter circumference wheels for metric measurement

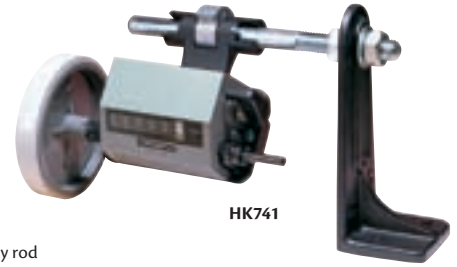

HK741

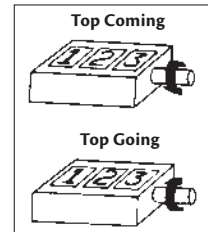

TRUMETER

TOP COMING

TOP GOING

Model No.	Mfg. No.	Model No.	Mfg. No.	Description	Price/Each
HK741	SR3MOTC	HK742	SR3MOTG	Counter, Metres Only	751.34
HK739	SR3MDTC	HK740	SR3MDTG	Counter, Metres and Decimetres	746.32
HK737	SR3FOTC	HK738	SR3FOTG	Counter, Feet Only	626.91
HK735	SR3FITC	HK736	SR3FITG	Counter, Feet and Inches	626.91
HK749	SR4MOTC	HK750	SR4MOTG	Counter, Metres Only	793.66
HK747	SR4MDTC	HK748	SR4MDTG	Counter, Metres and Decimetres	793.66
HK745	SR4FOTC	HK746	SR4FOTG	Counter, Feet Only	793.66
HK743	SR4FITC	HK744	SR4FITG	Counter, Feet and Inches	793.66
HK757	SR7MOTC	HK758	SR7MOTG	Counter, Metres Only	859.09
HK755	SR7MDTC	HK756	SR7MDTG	Counter, Metres and Decimetres	859.09
HK753	SR7FOTC	HK754	SR7FOTG	Counter, Feet Only	859.09
HK751	SR7FITC	HK752	SR7FITG	Counter, Feet and Inches	859.09
HB237	25-C7571/1	-	-	Imperial Wheel	62.00
HB238	25-C7905/1	-	-	Metric Wheel	65.43

WIRE MEASURERS

- Accommodates a wide variety of flexible materials, from 1/64" to 7/8" (4 to 24 mm) diameter
- Measures wire rope and similar stiff materials to 1/2" (13 mm) diameter
- Quickly interchangeable guide tubes with I.D.s of 1/4" (6.3 mm) and 1" (25 mm) afford accurate guiding of many hard to measure material
- Low friction, positive control guiding components assure straight-line contact with the measuring wheel so important to measure accuracy
- Stainless and heat-treated steel used for all shafts and surfaces subject to wear by material's passage
- Convenient release handles for quick and easy loading
- Mechanical counters rated at 1000 ft/min. (300 m/min.) are housed in sturdy, dust-tight cases
- Counters add or subtract and reset to zero with one turn of the knob

Model HD571: Reel forms a round coil which can be tied before collapsing. The coil off-loads to front.

Model HA917: Mounts on all 1400 Series measurers at the correct height in relation to payout and takeup reels (14" high).

Model HF242: Mounts at exit edge of measurer. Slicing action of blade cuts cleanly. Easily resharpened. Not intended for steel wire, armored cable or very fine wire.



HA481

Olympic

Model No.	Mfg. No.	Description	Price/Each
HA481	1410/B	Wire Measurer, Feet and Inches up to 9999'11"	407.00
HA486	1420/B	Wire Measurer, Meters and Decimeters up to 999.9m	407.00
HD571	99	Collapsible Reel and Stand	452.00
HA917	201	Stand	50.00
HF242	CUTTER-8	Wire Cutter	103.00

INSPECTION CAMERAS

- High visibility 3.2" colour TFT LCD monitor with 320 x 240 pixel resolution
- Flexible gooseneck imager head retains configured shape and is waterproof (IP67)
- High visibility 10° adjustable LED lighting
- Allows you to save high resolution JPG images and live video
- Transfer files to a computer via USB cable and optional 4 GB SD memory card
- Rechargeable lithium-ion battery
- Viewing distance: 15 cm to 25 cm (5.9" to 9.8")
- TV compatible
- Viewing angle: 0 to 180°
- Camera diameter: 17 mm (0.66"); Length: 1 m (39")
- Includes video borescope, imager head, magnet, hook and mirror attachments, 3.7 V lithium battery, DC power supply, USB cable, video output cable, user manual and hard carrying case



REED

Model No.	Mfg. No.	Description	Price/Each
IA674	BS-150	Video Inspection Camera	299.00
OM463	167130	Memory Card - 4 GB	14.80
IA679	BS-C6	6' Cable Extension	75.00

R8100 HIGH DEFINITION VIDEO BORESCOPIES

- High definition inspection scope detects and diagnoses problems without direct physical or visual access
- Provides real time imaging only
- High resolution 2.4" colour TFT LCD monitor with display resolution of 480 pixels W x 234 pixels H
- 0.66" (17 mm) imager head with 1 m flexible gooseneck retains configured shape and is waterproof
- Gooseneck is expandable up to 30' with optional cable extensions
- Four high visibility LED lights provide illumination
- 2X zoom button and 180° mirror rotation button
- Active Area: 48 mm x 35.6 mm
- Viewing Distance: 5.9 to 9.8" (15 to 25 cm)
- Viewing Angle: 0 to 180°
- Max. Resolution: 640 x 480
- Operates on 4 x 1.5 V "AA" batteries
- Includes: R8100 High Definition Video Borescope, Imager Head, Magnet, Hook and Mirror Attachments, Batteries



REED

Model No.	Mfg. No.	Description	Price/Each
IB752	R8100	High Definition Video Borescope	189.00
IA697	BS-15-9C3	Replacement Camera	119.00
IA679	BS-C6	Cable Extension	75.00

SEESNAKE® MICRO™ INSPECTION CAMERAS

RIDGID®

The CA-100 inspection camera allows you to perform more detailed visual inspections in even harder-to-reach areas. The micro™ CA-100 comes standard with a rugged 3/4" (17 mm) anodized aluminum camera head with four super bright LEDs. Easily rotate the active image counter-clockwise to see in any situation.

SPECIFICATIONS:

- Display:** 3.5" colour LCD (320 x 240 resolution)
- Camera head:** Aluminum 17 mm
- Lighting:** 4 adjustable LEDs
- Cable reach:** 3' (Expandable to 30' w/ optional extensions)
- Video output:** 3' RCA cable (included)
- Waterproof:** Camera head and cable to 10' (when properly assembled)
- Power source:** 4 AA batteries
- Attachments:** Mirror, hook and magnet



Model No.	Mfg. No.	Description	Price/Each
IA840	36738	micro™ CA-100 Inspection Camera	389.00
IA841	37103	17 mm Replacement Imager	124.00
IA842	37108	3' Cable Universal Extension	80.20
IA843	37113	6' Cable Universal Extension	147.00

MICRO™ CA-300 INSPECTION CAMERAS

Documentation made easy with the new Ridgid® micro™ CA-300 inspection camera. Easily record still images and videos of problems. Comfortable pistol-grip design, large screen, and rugged anodized aluminum camera head with four bright LEDs. Features image rotation and digital zoom.

SPECIFICATIONS:

- Display:** 3.5" (90 mm) colour TFT
- Camera diameter:** 0.66" (17 mm) LCD (320 x 240 resolution)
- Lighting:** 4 adjustable LEDs
- Cable reach:** 3' (0.9 m) (Expandable to 30' with optional extension also compatible with microDrain™, microReel™ and nanoReel™)
- Images:** JPG - Good (640 x 480), Better (1024 x 768), Best (1600 x 1200)
- Video:** AVI - Good (320 x 240), Best (640 x 480)
- External memory:** SD card up to 32 GB (4 GB SD card included)
- Power source:** Rechargeable 3.7 V Li-Ion battery
- Included:** micro™ CA-300 with 17 mm imager, battery, charger, USB card, hook, magnet and mirror accessories, RCA cable, AC adapter, headset with microphone, 4 GB SD card, 1-year RidgidConnect™ basic subscription



RIDGID®

Model No.	Mfg. No.	Description	Price/Each
IA844	37888	micro™ CA-300 Inspection Camera	679.00
IA841	37103	17 mm Replacement Imager	124.00
IA842	37108	3' Cable Universal Extension	80.20
IA843	37113	6' Cable Universal Extension	147.00
IA845	37083	3.7 V Li-Ion Battery	109.00
IA846	37098	3' (6 m) Imager Head	179.00

R9000 PIPE VIDEO INSPECTION SYSTEM

- Cost effective portable inspection camera
- Designed to deliver quality video inspection in a wide range of applications including: sewers, building ducts/piping, wells, and power plants
- System includes camera head, cable reel, battery pack and DVR
- Camera head contains 12 white LED lights, a flexible spring coiled joint to navigate corners, a scratch-resistant sapphire lens cover and a stainless steel housing that allows the camera to withstand various hits
- High resolution CCD chip is designed to capture bright, crisp, colour video of the inspection area
- Cable reel is mounted and rotatable in the case, therefore the cable can be extended without the need to hold the reel
- Sun visor is included to act as a sun shield for outdoor inspections
- DVR Resolution: 800 x 480 RGB • DVR Output: TV and Audio
- External Memory: Supports SD memory card up to 32GB
- Viewing Angle: 140° • Display Size: 7" • Camera Head: 0.9" (23 mm)

REED



Model No.	Mfg. No.	Description	Price/Each
IB751	R9000	Pipe Video Inspection System	1595.00

AIR VELOCITY METERS

ANEMOMETERS

- Data hold, Record (Max/Min)
- Integral vane design for one hand operation
- Push button operation
- Pocket-sized
- Includes battery
- Air Velocity Range:
80 to 5910 fpm; 0.4 to 30 m/s;
0.9 to 67 mph; 1.4 to 108 km/h;
0.8 to 58.3 knots



REED

Model No.	Mfg. No.	Description	Price/Each
HX286	LM-81 AM	Thermo-Anemometer	99.00

THERMO-ANEMOMETERS

- All-in-one meter with integral rotary vane sensor
- Simultaneous display of air velocity and temperature
- Selectable wind speed units: Knots, mph, km/h
- Calculate air volume by keying in area dimension
- Continuous moving air velocity averaging of measurements for up to 2 hours
- Displays Min/Max/Avg velocity with temperature values
- Multi-point averaging up to 8 points
- Calculate average velocity values in seconds
- High-contrast, 4-digit LCD readout
- RS-232 interface
- Data hold and auto power off
- Air Velocity Range: 80 to 5900 fpm; 0.4 to 30 m/s;
0.9 to 68 mph; 1.4 to 108 km/h; 0.8 to 58 knots
- Temperature Range: -10° to 50°C; 14° to 122°F



REED

Model No.	Mfg. No.	Description	Price/Each
IA040	8906	Thermo-Anemometer	249.00

THERMO-ANEMOMETERS

- 4-in-1 multi-function meter: anemometer, humidity meter, light meter and type-K digital thermometer
- Data hold, Record (Max/Min)
- Integral vane design for one hand operation
- Push button operation
- Pocket-sized
- Includes battery
- Air Velocity Range:
80° to 5910 fpm; 0.4 to 30 m/s;
0.9 to 67 mph; 1.4 to 108 km/h;
0.8 to 58.3 knots
- Temperature Range:
Air: 0° to 50°C; 32° to 122°F;
Input: -100° to 1300°C; -148° to 2372°F
- Humidity Range: 10 to 95% RH
- Light Range: 0 to 20,000 lux; 0 to 2,000 Ft-c



REED

Model No.	Mfg. No.	Description	Price/Each
HX285	LM-8000	Multi-Function Meter	199.00

THERMO-ANEMOMETERS

- Measures air velocity as well as temperature with a type J/type K thermocouple thermometer
- Low friction ball-bearing, rotating vane probe
- RS232 and USB interface
- Real time data logger with integral 4 GB SD memory card (optional)
- Air velocity is measured in m/s, ft/min, km/h, mph or knots
- Temperature is measured in °C or °F
- Air Velocity Range: 0.5 to 30.0 m/s
- Type J Temp. Range: -50 to 1200°C
- Type K Temp. Range: -50 to 1300°C



REED

Model No.	Mfg. No.	Description	Price/Each
IA796	SD-4207	Anemometer	395.00

THERMO-ANEMOMETERS

MEASURES AIR VELOCITY, AIR VOLUME & AIRSTREAM TEMPERATURE

- Newly developed reversible head for measuring air velocity at exhaust and inlet grilles with one instrument
- Sweep mode measures average air velocity or air volume over an area or period of time
- Displays measurements in metric or imperial units
- Ergonomically designed for high performance, unrivalled accuracy and ease of use
- Air Velocity Range: 0.25 to 30 m/s (50 to 6000 fpm)
- Temperature Range: 0 to 60°C (32 to 140°F)
- Volumetric Flow Rate: 1 to 999 999 l/s (1 to 9999 000 cfm)
1 to 999 999 m³/h, 0.1 to 3000 m³/s
- Optional AirCones quickly convert the model **HK666** into an air volume flow balancing tool
- Aerodynamic design for minimal resistance
- Two sizes suit most supply and extract grilles
- Self sealing for leak tight readings
- Constructed of hard wearing ABS
- Volume flow curves in m³/sec and cfm
- Air Volume Range:
0 to 0.1 m³/s (0 to 210 cfm)



ALNOR
A TSI Company

Model No.	Mfg. No.	Description	Price/Each
HK666	RVA801	Rotating Vane Thermo-Anemometer	882.31
IA116	801750	Volumetric Flow Hoods	382.05

Help control & divert traffic

100% PVC construction

High density base for maximum stability

Superior temperature resistance

ZENITH®
Safety Products

THERMO-ANEMOMETERS

- Mini-vane anemometer permits access to restricted areas
- Dual display indicates m/s, ft/min, km/h, knots, mph and °C/°F
- 13 mm diameter metal mini-vane and telescopic probe to 600 mm
- RS232 output
- Data hold, Record (Max/Min)
- Auto shut off
- Includes battery and hard carrying case
- Velocity Range: 0.2 to 12.0 m/s; 2.8 to 43.2 km/h; 1.8 to 26.8 mph; 160 to 2358 ft/m; 0.8 to 23.3 knots
- Temperature range: 32° to 176°F; 0° to 80°C



THERMO-ANEMOMETERS

- Measures air velocity as well as temperature with a type J/type K thermocouple thermometer
- Hot wire probe
- Real time data logger with integral 4 GB SD memory card (optional)
- RS232 and USB interface
- Air velocity is measured in m/s, ft/min, km/h, mph or knots
- Temperature is measured in °C or °F
- Air Velocity Range: 0.2 to 25.0 m/s
- Type J Temp. Range: -50 to 1200°C
- Type K Temp. Range: -50 to 1300°C



REED

Model No.	Mfg. No.	Description	Price/Each
HX340	YK-80 AS	Thermo-Anemometer	549.00

REED

Model No.	Mfg. No.	Description	Price/Each
IA797	SD-4214	Thermo-Anemometer	549.00
OM463	167130	Memory Card - 4 GB	14.80

MANOMETERS

- Measures gauge and differential pressure from 0 to 5 psi
- 11 selectable units of measure: psi, inH₂O, bar, mbar, kPa, inHg, mmHg, ozin², ftH₂O, cmH₂O, kgcm²
- Dual LCDs with backlighting
- Max/Min/Avg record with time stamp
- Data Hold freezes the displayed reading
- Low battery indication with auto power off
- Push button zero adjust and offset readings
- USB output
- Includes USB cable, tubing, hard carrying case and battery
- Accredited calibration available

SPECIFICATIONS:

Pressure Range:	5.000 psi; 138.3 inH ₂ O; 344.7 mbar; 34.47 kPa; 1.018 inHg; 258.5 mmHg; 80.00 ozin ² ; 11.53 ftH ₂ O; 351.5 cmH ₂ O; 0.351 kgcm ² ; 0.344 bar
Resolution:	0.001 psi; 0.1 inH ₂ O; 0.1 mbar; 0.01 kPa; 0.001 inHg; 0.1 mmHg; 0.01 ozin ² ; 0.01 ftH ₂ O; 0.1 cmH ₂ O; 0.001 kgcm ² ; 0.001 bar
Accuracy:	±0.3% f.s.
Repeatability:	±0.2% f.s.
Hysteresis:	±0.29% f.s.
Maximum Pressure:	20 psi
Response Time:	0.5 second
Power Supply:	Single 9V alkaline battery



ANEMOMETER/MANOMETERS

- Measure and display air velocity, air flow volume, pressure and ambient temperature with a single, compact unit
- Air velocity displayed in m/s, fpm, km/h, mph or knots
- Air flow displayed in cfm or cmm
- Pressure displayed in psi, mbar, inH₂O, mmH₂O or Pa
- Temperature displayed in °C or °F
- Max., Min. and Avg. readings
- Real time clock provides for time-stamped measurements
- Push button calculation of rectangular or circular duct areas
- Large LCD display with backlight
- Auto power off and low battery indication
- USB interface
- Includes black and white silica tubes, Pitot tube, power adapter, USB cable, 9V battery, CD software and carrying case

SPECIFICATIONS:

Pressure Range:	±5000 Pa; 0.752 psi; 50.00mbar; 20.07 inH ₂ O; 509.8 mmH ₂ O
Resolution:	1 Pa; 0.0001 psi; 0.01 mbar; 0.01 inH ₂ O; 0.1 mmH ₂ O
Accuracy:	±0.3% FSO
Repeatability:	±0.2% FSO
Linearity/Hysteresis:	±0.29% FSO
Air Velocity Range:	1.00 to 80.00 m/s; 200 to 15,733 fpm; 3.6 to 288.0 km/h; 2.24 to 178.66 mph; 2.0 to 154.6 knots
Resolution:	0.01 m/s; 1 fpm; 0.1 km/h; 0.01 mph; 0.1 knots
Accuracy:	±2.5% rdg.
Air Flow Range:	0 to 99.999 ft ³ /min; 0 to 99.999 m ³ /min
Resolution:	0.0001 to 100 ft ³ /min; 0.001 to 100 m ³ /min
Accuracy:	Function of air velocity and duct size
Temperature Range:	0 to 50.0°C; 32.0 to 122.0°F
Resolution:	0.1°C; 0.1°F
Accuracy:	±1.0°C; ±2°F
Power Supply:	Single 9V battery



REED

Model No.	Mfg. No.	Description	Price/Each
IA980	R3002	Digital Manometer	195.00
IA447	BS-9	Tripod	69.00

REED

Model No.	Mfg. No.	Description	Price/Each
IA979	R3001	Anemometer/Manometer	459.00

MANOMETERS

BALOMETERS

- Detachable manometer can be used with optional probes
- Reads in. H₂O, ft H₂O, PSI, in. Hg, mm Hg, m H₂O, kPa, mm Hg, bar
- Displays Min, Max and Average of up to 1000 readings
- Stores up to 1000 readings with time and date stamp
- Battery operated
- Includes CompuDat® software to download data to PC
- Shipped complete with manometer, 2' x 2' air capture hood/frame/base, 4 "AA" size rechargeable NiMH batteries, external battery charger, 18" pitot probe, 2 static pressure probes, 16 ft. neoprene tubing, wheeled carrying case, software and manual
- Diff. Pressure Range: ± 15 in. H₂O (3735 Pa)
- Absolute Pressure Range: 15 to 40 in Hg (356 to 1016 Hg)
- Air Velocity Range:
 - 25 to 8000 fpm (0.125 to 40 m/s) pitot tube; 25 to 5000 fpm (0.125 to 25 m/s) air flow probe; 25 to 2500 fpm (0.125 to 12.5 m/s) velocity matrix
- Air Volume Range: 25 to 2500 ft³/m (42 to 4250 m³/h)
- Humidity Range: 0 to 95% RH (optional probe)
- Temperature Range: -40° to 250°F (-40° to 121°C) probe dependent



IA120



Model No.	Mfg. No.	Description	Price/Each
IA120	EBT721	Balometer, Electronic Kit	5078.58
IA575	800187	Air Foil Probe	627.96
IA576	800188	Probe, Temperature	453.82
IA577	800189	Probe, Temp/RH	604.74
IA578	801090	16-Point Velocity Matrix w/Telescopic Handle	620.57
IA579	801206	Hood Expansion Kit, 2 hoods, 1' x 4' and 2' x 4'	794.72
IA580	801207	Hood Expansion Kit, 2 hoods, 1' x 5' and 3' x 3'	794.72

MICROMANOMETERS

MEASURE DIFFERENTIAL PRESSURE, AIR FLOW & VELOCITY WITH A SINGLE METER

- Colour-coded hoses and easy-to-read markings on meter reduce confusion often associated with interpreting pressure measurements
- Highly sensitive pressure measurements down to 0.001" H₂O cover most indoor applications
- Users can easily enter duct shape and dimensions in the meter and perform air flow calculations
- Conveniently capture readings with a single push of a button
- Store up to 99 readings
- Includes 12" Pitot tube, rubber hose, TPAK magnetic hanging strap, batteries and carrying case
- Pressure Range: ± 4000 Pa; ± 16" H₂O; ± 400 mm H₂O; ± 40 mbar; ± 0.6 PSI
- Air Velocity Range: 250 to 16 000 FPM; 1 to 80 m/s
- Air Volume Range: 0 to 99 999 CFM; 0 to 99 999 m³/h; 0 to 99 999 l/s
- Temperature Range: 0 to 50°C; 32 to 122°F

IA549



Model No.	Mfg. No.	Description	Price/Each
IA549	922/KIT	Micromanometer	1096.00

MANOMETERS

- Digital display of gauge or differential
- Select from one of 11 different pressure units
- Data hold
- Max/Min Record
- Display backlight
- Auto power off
- Low battery indicator
- Simple fittings for hose connection
- Optional RS-232 interface
- Includes hard carrying case, 9 V battery, connection hose and manual
- Pressure Range: **IA138:** 0 to 30 PSI; **IA139:** 0 to 100 PSI



IA138

REED

Model No.	Mfg. No.	Description	Price/Each
IA138	8230	Digital Manometer	239.00
IA139	82100	Digital Manometer	239.00

MANOMETERS

- Positive or negative pressure measurements
- Auto power off to conserve battery life
- Electronic zeroing function for offset measurements
- Large, easy-to-read display
- Extruded aluminum case
- Pressure Range: -20 to 20" w.c. (-50 to 50 mbar)



IA135



Model No.	Mfg. No.	Description	Price/Each
IA135	476A-0	Digital Manometer	140.00

MANOMETERS

- Instant selection from up to nine English/metric units: PSID, in H₂O, mm H₂O, in Hg, mm Hg, Pa, kPa, bar, Mbar
- Stores 20 readings in memory for later reference
- Measure positive, negative or differential pressures
- Audible and visual overpressure alarms
- Large, easy-to-read 0.4" LCD readout includes switchable backlight
- Electronic zeroing lets you null out any minor differences
- Display hold key freezes current pressure reading
- Operates up to 100 hours on a single 9 Volt battery
- Auto shut-off to minimize battery drain
- FM approved as intrinsically safe for hazardous locations Class 1, Div. 1, Group A, B, C, D, T4.



HM543



Model No.	Mfg. No.	Range	Price/Each
HM543	477-1-FM	0-20 in. w.c./0-5 kPa	607.00
HM544	477-2-FM	0-40 in. w.c./0-10 kPa	504.00
HM545	477-3-FM	0-200 in. w.c./0-50 kPa	504.00
HM546	477-4-FM	0-10 PSID/0-70 kPa	504.00
HM547	477-5-FM	0-30 PSID/0-200 kPa	504.00
IA136	477-6-FM	0-100 PSID/0-700 kPa	504.00
IA137	477-7-FM	0-150 PSID/0-1000 kPa	504.00

MANOMETERS & PRESSURE GAUGES

PROCESS GAUGES

- Stamped aluminum 4 1/2" (115 mm) diameter dial
- Black, impact resistant phenolic case
- 316 stainless steel bourdon tube and socket
- Silicone fluid filled and rated for -50° to 170°F
- 1/2% of full scale accuracy
- Transient over-pressure limit: 30%
- Restrictor screw
- Shatterproof glass lens
- Integral back flange
- Safety blowout backplate
- Micrometer adjustable pointer
- 1/4" or 1/2" NPT male connection bottom



IA361

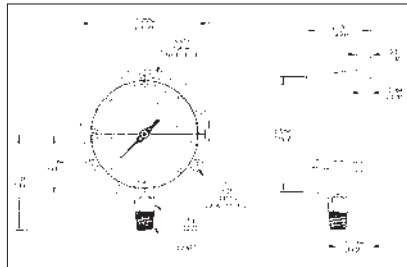

PRESSURE GAUGES

- 2.5" diameter dial has dual English/metric scales
- ASME Grade B accuracy: ± 3% first 3rd of scale, ± 2% middle 3rd of scale, and ± 3% last 3rd of scale
- Corrosion resistant stainless steel case and ring, acrylic lens
- Brass internal materials
- 1/4" NPT bottom connection only
- Rated for -20 to 60°C and pressure steady at 75% f.s.



IA285

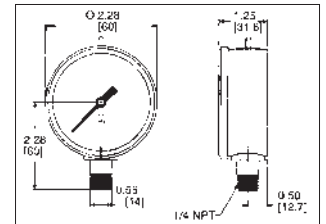

REED

1/4" NPT		1/2" NPT		Dial Ranges	Price /Each
Model No.	Mfg. No.	Model No.	Mfg. No.		
IA399	LF45-15-1/4	IA351	LF45-15-1/2	30"-0-15 PSI	129.00
IA335	LF45-30-1/4	IA352	LF45-30-1/2	30"-0-30 PSI	129.00
IA336	LF45-60-1/4	IA353	LF45-60-1/2	30"-0-60 PSI	129.00
IA337	LF45-30HG-1/4	IA354	LF45-30HG-1/2	30"-0 Hg Vac.	129.00

1/4" NPT		1/2" NPT		Compound Scale Dial Ranges	Price /Each
Model No.	Mfg. No.	Model No.	Mfg. No.		
IA338	LF45-15P-1/4	IA355	LF45-15P-1/2	0-15 PSI/0-100 kPa	129.00
IA339	LF45-30P-1/4	IA356	LF45-30P-1/2	0-30 PSI/0-200 kPa	129.00
IA340	LF45-60P-1/4	IA357	LF45-60P-1/2	0-60 PSI/0-400 kPa	129.00
IA341	LF45-100P-1/4	IA358	LF45-100P-1/2	0-100 PSI/0-700 kPa	129.00
IA342	LF45-160P-1/4	IA359	LF45-160P-1/2	0-160 PSI/0-1100 kPa	129.00
IA343	LF45-200P-1/4	IA360	LF45-200P-1/2	0-200 PSI/0-1400 kPa	129.00
IA344	LF45-300P-1/4	IA361	LF45-300P-1/2	0-300 PSI/0-2100 kPa	129.00
IA401	LF45-400P-1/4	IA362	LF45-400P-1/2	0-400 PSI/0-2800 kPa	129.00
IA345	LF45-600P-1/4	IA363	LF45-600P-1/2	0-600 PSI/0-4200 kPa	129.00
IA400	LF45-1500P-1/4	IA365	LF45-1500P-1/2	0-1500 PSI/0-10,500 kPa	129.00
IA347	LF45-2000P-1/4	IA366	LF45-2000P-1/2	0-2000 PSI/0-14,000 kPa	129.00
IA348	LF45-3000P-1/4	IA367	LF45-3000P-1/2	0-3000 PSI/0-21,000 kPa	129.00
IA350	LF45-10000P-1/4	IA369	LF45-10000P-1/2	0-10,000 PSI/0-70,000 kPa	129.00

PRESSURE GAUGES

- 4.5" diameter dial has dual English/metric scales
- Balanced adjustable black pointer
- Corrosion resistant stainless steel case and ring, plastic lens
- Soft soldered phosphor bronze tube with brass socket recommended for average general use
- Suitable for steam, water, air, oil, gas or any medium not corrosive to copper alloys
- 1/4" NPT bottom connection only
- 1% accuracy



IA328

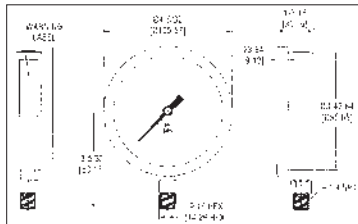

REED

Model No.	Mfg. No.	Dial Range	Figure Intervals	Smallest Graduation	Price /Each
IA326	421 AVND-30	0-30 PSI/0-200 kPa	5 PSI	0.5 PSI	44.00
IA327	421 AVND-60	0-60 PSI/0-400 kPa	10 PSI	1 PSI	44.00
IA328	421 AVND-100	0-100 PSI/0-700 kPa	10 PSI	1 PSI	44.00
IA329	421 AVND-160	0-160 PSI/0-1100 kPa	20 PSI	2 PSI	44.00
IA330	421 AVND-200	0-200 PSI/0-1400 kPa	20 PSI	2 PSI	44.00
IA331	421 AVND-300	0-300 PSI/0-2100 kPa	50 PSI	5 PSI	44.00
IA332	421 AVND-500	0-500 PSI/0-3500 kPa	50 PSI	5 PSI	44.00
IA333	421 AVND-30 VAC	30"-0 Hg Vac	5"	0.5"	44.00

REED

Bottom Conn.		Price /Each	Back Conn.		Price /Each	Compound Scale Dial Ranges
Model No.	Mfg. No.		Model No.	Mfg. No.		
IA292	AVNC-30HG	23.00	IA309	AHNC-30HG	29.00	30" Hg-0" Vac.
IA293	AVNC-30	23.00	IA310	AHNC-30	29.00	30" Hg-0-30 PSI
IA294	AVNC-15P	23.00	HX508	AHNC-15P	29.00	0-15 PSI/0-100 kPa
IA295	AVNC-30P	23.00	IA312	AHNC-30P	29.00	0-30 PSI/0-200 kPa
IA296	AVNC-60P	23.00	IA313	AHNC-60P	29.00	0-60 PSI/0-400 kPa
IA297	AVNC-100P	23.00	IA314	AHNC-100P	29.00	0-100 PSI/0-700 kPa
IA298	AVNC-160P	23.00	IA315	AHNC-160P	29.00	0-160 PSI/0-1100 kPa
IA299	AVNC-200P	23.00	IA316	AHNC-200P	29.00	0-200 PSI/0-1400 kPa
IA300	AVNC-300P	23.00	IA317	AHNC-300P	29.00	0-300 PSI/0-2100 kPa
IA301	AVNC-400P	23.00	IA318	AHNC-400P	29.00	0-400 PSI/0-2800 kPa
IA302	AVNC-600P	23.00	IA319	AHNC-600P	29.00	0-600 PSI/0-4200 kPa
IA303	AVNC-1000P	23.00	IA320	AHNC-1000P	29.00	0-1000 PSI/0-7000 kPa
IA304	AVNC-1500P	23.00	IA321	AHNC-1500P	29.00	0-1500 PSI/0-10,500 kPa
IA305	AVNC-2000P	23.00	IA322	AHNC-2000P	29.00	0-2000 PSI/0-14,000 kPa
IA306	AVNC-3000P	23.00	IA323	AHNC-3000P	29.00	0-3000 PSI/0-21,000 kPa
IA307	AVNC-5000P	23.00	IA324	AHNC-5000P	29.00	0-5000 PSI/0-35,000 kPa
IA308	AVNC-6000P	23.00	IA325	AHNC-6000P	29.00	0-6000 PSI/0-42,000 kPa

PRESSURE GAUGES

- Stamped aluminum 2.5" diameter dial
- Polished stainless steel case
- Glass lens, pressed bezel
- Bronze tube and brass socket with brass movement
- 1/4" male NPT connection, bottom or back
- 1.6% accuracy
- Glycerine fill provides a dampening effect which minimises pulsations; continuously lubricates gauge movement; and makes this gauge ideally suited for adverse environments



IA297

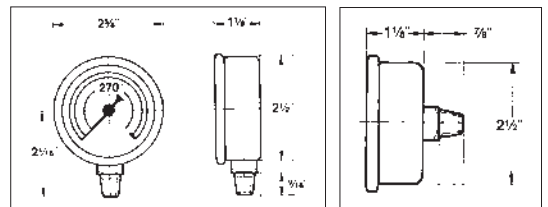

REFRACTOMETERS



REFRACTOMETERS

BRIX REFRACTOMETERS

The Brix refractometer shows the concentration percentage of the soluble solids content (Total solids) of a sample (water solution). The soluble solids content is the total of all the solids dissolved in the water - beginning with sugar, salts, protein, acids, etc. and the measurement reading value is the value of the sum total of those. Essentially Brix% is calibrated to the number of grams of cane sugar contained in 100 g of cane sugar solution. So, when measuring a sugar solution, the Brix% should perfectly match the actual concentration.

REED



HX107

Model No.	Mfg. No.	BRIX Range	Min. Div.	Accuracy	Price/Each
HX107	R9500	0 - 32%	0.2%	± 0.2%	119.00
HX355	MT-090	58 - 90%	1.0%	± 0.5%	99.00

SALINITY REFRACTOMETERS

Salinity refractometers are useful for measuring the concentration of natural or artificial seawater in aquariums, holding tanks, and breeding ponds. They can also be used for controlling the salt water concentration when preparing pickles, measuring the concentration of salt water used in rinsing and cooking sea products.

REED



HK668

Model No.	Mfg. No.	Range	Min. Div.	Accuracy	Price/Each
HK668	R9600	0 - 28%	0.2%	± 0.2%	119.00

BATTERY COOLANT CHECKERS

It is essential to know the concentration and freezing point of anti-freeze coolants for vehicular safety. Keeping a suitable concentration of coolant prevents engine trouble and possible radiator corrosion. This tester monitors the freezing point of both ethylene glycol and propylene glycol; in addition, it indicates battery recharge level. This tester is simple to use; requiring only a few drops to provide accurate readings within seconds. It is virtually indispensable for gas stations, service shops, cab companies, etc.

REED



HX093

Model No.	Mfg. No.	Coolant	Range	Min. Div.	Price/Each
HX093	R9700	Propylene Glycol	-50 to 32 °F	10 °F	119.00
		Ethylene Glycol	-50 to 32 °F	10 °F	

See pages 386 - 406 for Eye Protection section



PH METER

- Dual displays of temperature and pH
- °F or °C temperature measurement
- Automatic temperature compensation assures that readings are corrected for temperature offsets
- One touch calibration for up to 3 points
- Calibration values are adjustable
- Includes batteries
- pH Range: 0.00 to 14.00 pH
- Temperature Range: 0 to 60.0°C
- Accredited calibration available



REED

Model No.	Mfg. No.	Description	Price/Each
IA693	8689	Digital pH Pen	119.00
IA694	86P8	Replacement pH Electrode	49.00
HX298	PH-04	4.0 pH Buffer Solution	15.00
HX299	PH-07	7.0 pH Buffer Solution	15.00

PH/ORP METERS

- Measures pH and ORP levels in water
- Manual or automatic temperature compensation
- Auto calibration for pH 4.0, pH 7.0 and pH 10.0
- Data hold and max./min. record
- Real time data logger with integral 4 GB SD memory card (optional)
- RS232 and USB interface
- pH Range: 0 to 14.00 pH
- ORP Range: -1999 to 1999 mV



IA801

REED

Model No.	Mfg. No.	Description	Price/Each
IA801	SD-230	pH/ORP Meters	249.00
OM463	167130	Memory Card - 4 GB	14.80

Model No.	Mfg. No.	Description	Range	Size	Price/Each
HX295	PE-01	Epoxy pH Electrode	0-14 pH	9.5 mm dia. x 130 mm	129.00
HX296	PE-03	Epoxy pH Electrode	0-13 pH	12.3 mm dia. x 160 mm	69.00
HX297	PE-11	Epoxy pH Electrode	0-13 pH	10.0 mm dia. x 130 mm	79.00

CONDUCTIVITY METERS

- Measures conductivity, total dissolved solids (TDS) and salt levels in water
- Carbon rod electrode
- Auto temperature compensation
- Temperature coefficient of measurement solution is user selectable
- Data hold and Max/Min record
- Real time data logger with integral 4 GB SD memory card (optional)
- RS232 and USB interface
- Conductivity Range: 200 µS, 2 mS, 20 mS, 200 mS
- Soft Range: 0 to 12% salt (% weight)



IA802

REED

Model No.	Mfg. No.	Description	Price/Each
IA802	SD-4307	Conductivity Meter	379.00
OM463	167130	Memory Card - 4 GB	14.80

See page 28 for Sample Storage Bottles



DIGITAL COUNTING SCALES

- Used for counting and quantity checking
- Primary counting function
- High accuracy load cell
- Large LCD display
- Rechargeable battery
- Full digital calibration
- Tare function
- Auto zero tracking
- Quantity set alarm (checking)
- Back light display
- Accumulation memory quantity
- 1-year warranty



HX133



NOT LEGAL FOR TRADE

Model No	Mfg. No.	Capacity lbs./kg	Graduation lbs./g	Counting Resolutions	Price /Each
HX133	KCS 301-30	66/30	0.002/1	1/30 000	589.00
IA590	KCS 301-15	33/15	0.001/0.5	1/30 000	589.00
IB732	KCS 301-3	6.6/3	0.0002/0.1	1/30 000	589.00
IB733	KCS 301-6	13.2/6	0.0004/0.2	1/30 000	589.00

ELECTRONIC DIGITAL WEIGHING SCALES

- Compact design 12 1/2" D x 11 3/4" W x 45/8" H (32 cm x 30 cm x 12 cm)
- Check-weighing function (HI/LO/Target) and a secondary counting function
- Four weighing modes (g, kg, lbs., oz.)
- Removable stainless steel platform 11 3/4" D x 8 3/4" W (30 cm x 22 cm)
- ABS enclosure
- Large LCD display with both front and rear indicators and level indicator for weighing accuracy
- Rechargeable battery with low battery indicator and AC adapter (included)



IA991



Model No.	Mfg. No.	Capacity kg/g/lbs./oz.	Graduation kg/g/lbs./oz.	Price /Each
NOT LEGAL FOR TRADE				
IA988	KWS-SW06	3/3000/6/96	0.001/1/0.002/0.05	365.00
IA989	KWS-SW12	6/6000/12/192	0.002/2/0.005/0.1	365.00
IA990	KWS-SW30	15/15 000/30/480	0.005/5/0.01/0.2	365.00
IA991	KWS-SW60	30/30 000/60/960	0.01/10/0.02/0.5	365.00
LEGAL FOR TRADE				
IA992	KWS-SW06	3/3000/6/96	0.001/1/0.002/0.05	469.00
IA993	KWS-SW12	6/6000/12/192	0.002/2/0.005/0.1	469.00
IA994	KWS-SW30	15/15 000/30/480	0.005/5/0.01/0.2	469.00
IA995	KWS-SW60	30/30 000/60/960	0.01/10/0.02/0.5	469.00

PORTION CONTROL SCALE

- Auto off (after 120 seconds of inactivity)
- Full tare capacity
- Bright-blue backlit LCD display
- Low battery and overload indications
- Stainless steel platform
- Transparent cover protects the scale when not in use
- 7 Weighing modes: kg, lbs., g, oz., lb-oz, lb-1/4oz, 1/4oz
- Power supply: 4 x AA rechargeable batteries and power adapter included
- Capacity: 33 lbs. / 15 kg.
- Graduations: 2 g
- Platform Dimensions: 7" L x 7" W

Model No. IB735
Mfg. No. 601SC
Price/Each \$159.00



NOT LEGAL FOR TRADE



WEIGHING SCALES

- Ideal for high humidity and dusty work environment
- Large stainless steel platform is removable for easy cleaning
- Convenient displays on front and rear of the scale allow use from both sides of the worktable
- Meets IP66 (dust tight and protected against a strong water jet) standards

FEATURES:

- Large LCD type display with backlight
- ABS enclosure
- Water and dust resistant
- Secondary counting function
- Four direct keys: Zero, tare, units/counting, on/off
- Four weight modes: g, kg, oz., lb.
- Operates on A/C power or rechargeable battery (both included)
- Dimensions: 9" W x 9.5" D x 5.75" H



PE129



Model No	Mfg. No.	Capacity lbs./kg	Graduation lbs./kg	Price /Each
NOT LEGAL FOR TRADE				
PE126	KWD 500-5	5/2.5	0.002/0.001	425.00
PE127	KWD 500-10	10/5	0.005/0.002	425.00
PE128	KWD 500-20	20/10	0.01/0.005	425.00
PE129	KWD 500-50	50/20	0.02/0.01	425.00
LEGAL FOR TRADE				
IA591	KWD 500-5	5/2.5	0.002/0.001	546.00
IA592	KWD 500-10	10/5	0.005/0.002	546.00
IA593	KWD 500-20	20/10	0.01/0.005	546.00
IA594	KWD 500-50	50/20	0.02/0.01	546.00

RANGER® COUNT 3000 COMPACT BENCH COUNTING SCALES

A high-precision dedicated counting scale with advanced software for counting and packaging parts.

- Weighing Functions: lbs, oz, lbs:oz, kg or g
- Application Modes: Weighing, Parts Counting, Checkweighing, Checkcounting, Accumulation
- Display: 3-Window, 1 in. / 26 mm high LCD display with white backlight, 6-digit, 7-segment
- Checkweighing Indicators: 3 LED (yellow, green, red) with configurable operation and alert beeper
- Memory: 30 item library data storage function
- Zero Range: 2% or 10% of full scale capacity
- Tare Range: Full capacity by subtraction
- Stabilization: one second results, with 1 part in 1.5 million precision
- Power: 100-240 VAC/50-60 Hz internal universal power supply, internal rechargeable lead acid battery
- Interface Built-in RS232, optional 2nd platform, 2nd RS232, USB, Ethernet
- Platform Size: 11.8" W x 8.9" D

IA998



NOT LEGAL FOR TRADE

Model No.	Mfg. No.	Capacity kg/g/lbs./oz.	Graduation kg/g/lbs./oz.	Price /Each
IA998	RC1P1502	1.5/1500/3/48	0.00005/0.05/0.0001/0.002	899.00
IA999	RC31P3	3/300/6/96	0.00001/0.01/0.0002/0.005	899.00
IB001	RC31P6	6/6000/15/240	0.00002/0.02/0.0005/0.001	899.00
IB002	RC31P15	15/15 000/30/480	0.0005/0.5/0.001/0.02	899.00
IB003	RC31P30	30/30 000/60/960	0.001/1/0.002/0.05	899.00

SCALES

PORTABLE ELECTRONIC BALANCES

- Scout® Pro is a portable balance designed to meet the most common weighing equipments
- Features a large LCD display
- Removable stainless steel pan
- Weight display in g, kg, oz., lbs., lb.oz.; and Troy ounce or pennyweight units for weighing precious materials
- Powered by four AA batteries (not included) or included AC adaptor pack
- Dimensions: 6.0" W x 6.3" D x 2.2" H
- Weight: 1.8 lbs.
- 2-year warranty on parts and labour



HM315

MULTIPLE WEIGHING MODES:

- Parts counting
- % weighing
- Display hold for shipping applications



HX216



NOT LEGAL FOR TRADE

Model No.	Mfg. No.	Capacity	Graduation	Pan Size"	Price /Each
HX216*	SPX202	200 g	0.01 g	4.7 diameter	599.00
HX217*	SPX402	400 g	0.01 g	4.7 diameter	859.00
IA550*	SPX602	600 g	0.01 g	4.7 diameter	999.00
HX218*	SPX422	400 g	0.1 g	4.7 diameter	339.00
HM315*	SPX601	600 g	0.1 g	5.5 x 6.5	499.00
IA551	SPX2001	2000 g	0.1 g	5.5 x 6.5	638.00
IA553	SPX6001	6000 g	0.1 g	5.5 x 6.5	999.00
IA554	SPX6000	6000 g	1 g	5.5 x 6.5	528.00
HM065	76288-01		Security Device		139.00
HM316	77256-01		Carrying Case		199.00

* Span calibration mass included

LOW PROFILE BENCH SCALES

The ES Series design makes this low profile scale perfect for shipping, receiving and general bench applications. Easy 2-button operation and large display guarantees accurate and unmistakable results. The 3-way mounting bracket (included) allows you to mount the indicator to front of scale base, above the base, or to any vertical surface.

- Display weight in kg, lbs., oz. or combined lb.oz.
- Stainless steel weighing platform and epoxy painted steel frame
- AC or battery powered operation
- Includes: 3-way mounting bracket and AC adapter
- 1-year warranty on parts and labour



HN272



NOT LEGAL FOR TRADE

Model No.	Mfg. No.	Capacity lbs./kg/oz.	Readability lbs./g/oz.	Platform Dimensions L" x W" x H"	Price /Each
HN272	ES30R	66/30/1056	0.05/10/0.5	12.2 x 10.8 x 1.5	1089.00
HN273	ES50R	110/50/1760	0.05/20/1	12.2 x 10.8 x 1.5	1089.00
HN274	ES50L	110/50/1760	0.05/20/1	20.5 x 15.7 x 3	1159.00
HN275	ES100L	220/100/3520	0.01/50/2	20.5 x 15.7 x 3	1159.00
HN276*	ES200L	440/200/7040	0.02/100/5	20.5 x 15.7 x 3	1159.00

* lb.oz. display not available on model HN276

PORTION CONTROL SCALES

- Large LCD display - 5/8" high
- Removable stainless steel platform
- Tare weighing function
- 800-hours of battery life
- 2-mode function metric and imperial
- AC adaptor (included) or four AA batteries (not included)

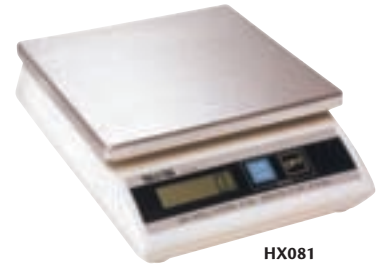

HX081



TANITA

NOT LEGAL FOR TRADE

Model No.	Mfg. No.	Capacity	Graduation	Price/Each
HX081	KD-200-110	35 oz./1000 g	0.05 oz./1 g	189.00
HX082	KD-200-210	70 oz./2000 g	0.1 oz./2 g	189.00
IA557	KD-200-510	11 lbs./5000 g	0.2 oz./5 g	189.00

PORTION CONTROL SCALE

- Stainless steel easy wipe top
- Quick response
- Overload indicator
- 0.1 oz. increments
- Tare
- Auto power off
- Certification : CE and NSF approved
- Powered by 2 x AAA batteries
- Display: LCD 2.17" x 0.83"
- Accuracy: +/- 0.5%
- Capacity: 5000 g / 9 lbs.
- Graduations: 1 g / 0.1 oz.
- Platform dimensions: 8 1/4" L x 5 7/8" W

Model No. IB734
Mfg. No. 6005C
Price/Each \$65.40



NOT LEGAL FOR TRADE

COMPACT ELECTRONIC SCALES

- Displays results in g or combined lb:oz
- One-button operation
- Full capacity tare
- LCD display
- Operates on three AAA batteries (included) or with an optional AC adapter
- Dimensions: 5.3" W x 7.6" D x 1.5" H
- 1-year warranty on parts and labour
- Weight: 1 lb.



HN218



NOT LEGAL FOR TRADE

Model No.	Mfg. No.	Capacity	Graduation	Price/Each
HN218	CS200	0 lb:7.05 oz./200 g	0.01 oz./0.1 g	194.00
HN219	CS2000	4 lb:6.55 oz./2000 g	0.05 oz./1.0 g	194.00
HN220	CS5000	11 lb:0.4 oz./5000 g	0.1 oz./2.0 g	227.00
IB538	46001724	Optional AC Power Adapter		89.90

ECONOMY PRECISION SCALES

- Maximum efficiency at minimal cost
- Top loading scales have a removable stainless steel platter making them easy to keep clean
- Speed and precision at a low price
- Ideal for small lab and educational environments

FEATURES:

- External calibration, brushed stainless steel platter and adapter
- Weights in g, oz., lbs., dwt, oz. t., cnt
- Counting features
- Operating temperature: 10°C to 35°C
- Dimensions: 7" W x 9 3/4" D x 2 1/2" H
- 1-year warranty



PE130



PE131



NOT LEGAL FOR TRADE

Model No.	Mfg. No.	Capacity	Graduation	Platter Dimension	Price/Each
PE130	KLE-200	200 g	0.1 g	4.6" diameter	210.00
PE131	KLE-2000	2000 g	1 g	5" x 6.5"	210.00

PRECISION SCALES

- Fast microprocessing speed and digital filtration are the key to peak performance and stability
- Single direction RS-232 allows you to connect to peripheral devices
- Leveling bubble is included and all four feet are adjustable
- Features external calibration
- Brushed stainless steel platter and adapter
- Weights in g, oz., lbs., dwt, oz. t., cnt and KHA 0.01 g also weights in CT
- Counting features
- Operating temperature: 10°C to 35°C
- 1-year warranty

PE136



PE137

NOT LEGAL FOR TRADE

Model No.	Mfg. No.	Capacity	Graduation	Platter Dimensions W" x D"	Price /Each
IA780	KHA-230R	200 g	0.001 g	4.75 x 4.75	794.00
PE136	KHA-1000R	1000 g	0.01 g	4.75 x 4.75	566.00
PE137	KHA-1201R	1200 g	0.1 g	6.94 x 6.94	385.00
IA781	KHA-5001R	5000 g	0.1 g	6.94 x 6.94	439.00



PESOLA® MICRO SPRING SCALES

- Rotatable bow allows for ideal position of scale reading
- Screw for tare and for adjusting the zero position (range of tare = 20%)
- Innovative adjustment and suspension of spring
- Precise graduation, high resolution, abrasion-resistant and anodized colour
- Eye-clip with lower suspension rotates by 360°
- Eye-clip allows easy interchange of lower suspension with other accessories
- Vertical measuring position



Model No.	Mfg. No.	Capacity	Graduation	Price /Each
IB694	20010	10 g	0.1 g	77.00
IB695	20030	30 g	0.25 g	70.00
IB696	20060	60 g	0.5 g	70.00
IB697	20100	100 g	1.0 g	70.00

PESOLA® MEDIO SPRING SCALES

- Rotatable bow allows for ideal position of scale reading
- Screw for tare and for adjusting the zero position (range of tare = 20%)
- Innovative adjustment and suspension of spring
- Precise graduation, high resolution, abrasion-resistant and anodized colour
- Integrated recoil absorption (important for tensile tests with drag pointer 4.012 (IB721))
- Clear marker reading line on level of graduation
- Eye-clip allows easy interchange of lower suspension with other accessories



Model No.	Mfg. No.	Capacity	Graduation	Price /Each
IB698	40300	300 g	2 g	83.00
IB699	40600	600 g	5 g	83.00
IB700	41000	1000 g	10 g	83.00
IB701	41002	1000 g	10 g	86.00
IB702*	42500/A	2500 g	20 g	86.00
IB703*	43000	3000 g	30 g	99.90

* Supplied with J hook

PESOLA® MACRO SPRING SCALES

- Rotatable bow allows for ideal position of scale reading
- Screw for tare and for adjusting the zero position (range of tare = 20%)
- Innovative adjustment and suspension of spring
- Precise graduation, high resolution, abrasion-resistant and anodized colour
- Integrated recoil absorption for tensile tests with drag pointer (drag pointer supplied)
- Clear marker reading line on level of graduation
- Swivel hook, rotatable and replaceable by different accessories



Model No.	Mfg. No.	Capacity	Graduation	Price /Each
IB705	80005	5 kg	50 g	170.00
IB707	80015	10 lbs./5 kg	50 g/2 oz.	174.00
IB706	80010	10 kg	100 g	173.00
IB712	80210	20 lbs./10 kg	100 g/4 oz.	177.00
IB708	80020	20 kg	200 g	176.00
IB713	80420	40 lbs./20 kg	200 g/8 oz.	180.00
IB709	80035	35 kg	500 g	182.00
IB710	80050	50 kg	500 g	212.00
IB711	80150	100 lbs./50 kg	500 g/1 lbs.	215.00

SCALES

TOP LOADING SCALES

- Brushed stainless steel body and stainless platform
- Portable rugged and reliable
- Bold large numbers for easy readability
- Rotating dial
- Tare function

BIOS
Professional



Model No.	Mfg. No.	Capacity	Graduation	Platform Dim. L" x W"	Price /Each
NOT LEGAL FOR TRADE					
IB736	620SC	2.2 lbs./1 kg	5 g/0.25 oz.	6 x 6	55.40
IB737	621SC	5 lbs./2.2 kg	5 g/0.5 oz.	6 x 6	65.40
IB738	622SC	25 lbs./12 kg	50 g/0.125 lbs.	8 x 8	75.50

TOP LOADING SCALES

- Large stainless steel and enamel platforms to accommodate a variety of package sizes
- Bold graphics improves reading accuracy and ease
- Portable, rugged and reliable

KILOTECH
www.kilotech.com



Model No.	Mfg. No.	Capacity	Case Finish	Platform Dim. W" x D"	Price /Each
PE446	KAM1101PL	11 lbs./5 kg	Enamel	7 1/2 x 7 1/2	149.00
PE447	KAM2501SPL	26 lbs./12 kg	S. Steel	7 1/2 x 7 1/2	149.00
PE449	KAMS002PL	50 lbs./22 kg	Enamel	10 3/4 x 9 1/2	165.00

DIGITAL LUGGAGE SCALE

- Blue back light LCD display
- Compact modern design
- Nylon strap
- Dual display (lbs. and kg at the same time)
- Auto-calibration
- Auto zero & auto off
- Hold function - Screen turns red when finished weighing
- Long life lithium batteries included
- Capacity: 110 lbs. / 50 kg
- Graduations: 0.5 lbs.

Model No. IB739
Mfg. No. SC419
Price/Each \$25.10

BIOS
Professional



BRIEFCASE/UTILITY MECHANICAL RECEIVING SCALES

This general purpose, portable weighing scale can be used in shipping and receiving areas. The large dual dial is easy to read from either the top or side position. The memory lock lever will hold the reading when dial is obscured by an oversized package.



Model No.	Mfg. No.	Capacity	Graduation	Dimensions L" x W" x H"	Price /Each
HL933	FPG250S	250 lbs.	1 lb.	13 1/4 x 10 1/2 x 3 7/8	139.00
HX655	FGP114S	114 kg	0.5 kg	13 1/4 x 10 1/2 x 3 7/8	149.00

Rubbermaid
Commercial Products

RECEIVING SCALES

These scales are heavy-duty, general purpose and are suitable for light industrial or shipping applications.

FEATURES:

- Kg/lbs. modes
- Programmable Auto-Off function
- Removable stainless steel platform (HX632, HX633, IA558, IA782, and IA783)
- Fixed mild steel checkered platform (IA564 and IA453)
- 4 1/2" x 1 1/2" LCD display (HX632, HX633 and IA558)
- 3" x 1 1/4" LCD display (IA564 and IA453)
- Platform size: 11.75" x 12.25" (HX632, HX633, IA558, IA564 and IA453)
- 14" x 16" (IA752 and IA783)
- Zero, tare and kg/lbs. (toggle) keys
- Heavy-duty 8' coiled cord
- Power supply: Six AA alkaline batteries (not included) or 120 V AC adapter (included)
- 1-year warranty



NOT LEGAL FOR TRADE

Model No.	Mfg. No.	Capacity	Graduation	Price/Each
HX632	KPS-50-2	110 lbs./50 kg	0.05 lbs./20 g	347.00
HX633	KPS-100-2	220 lbs./100 kg	0.1 lbs./50 g	347.00
IA558	KPS-150-2	330 lbs./150 kg	0.2 lbs./100 g	347.00
IA564	KPS-68MS	150 lbs./68 kg	0.2 lbs./100 g	288.00
IA782	KPS-60SS	130 lbs./60 kg	0.05 lbs./20 g	416.00
IA783	KPS-150SS	330 lbs./150 kg	0.1 lbs./50 g	416.00
IA453	KPS-180MS	400 lbs./180 kg	0.5 lbs./200 g	288.00

INTEGRATOR C15 PRICE COMPUTING SCALE

- Price computing simplified- Easy to use, easy to learn, and easy to program
- Visible in all lighting conditions
- Portable -No need to plug in the scale, 12 hour rechargeable battery included
- Multi-interval device-Two scales in one- Finer precision or larger capacity as per your requirements
- 265 PLU- memorizes item name, item code, life, ingredients, Tare & unit price
- Large stainless steel platter
- Dual reading displays (front and rear)
- Printer available as an option
- Platform Dimensions: 8-9/10" L x 13-1/5" W



Model No.	Mfg. No.	Capacity	Graduation	Price/Each
NOT LEGAL FOR TRADE				
IB772	851509	30 lbs./15kg	0.005 lbs./0.002 kg	469.00
IB774	851510	60 lbs./30kg	0.02 lbs./0.005 kg	469.00
LEGAL FOR TRADE				
IB773	881509	30 lbs./15kg	0.005 lbs./0.002 kg	549.00
IB775	881510	60 lbs./30kg	0.02 lbs./0.005 kg	549.00

ARGOX THERMAL LABEL PRINTER

- Thermal barcode printer
- Built in tear off bar
- Label separator
- Works with labels (IB783) 58 x 40 mm, (IB784) 58 x 60 mm

Model No. IB782
Mfg. No. 835501
Price/Each \$699.00



KILOTECH LABELS

Model No.	Mfg. No.	Label Size	Labels /Roll	Rolls /Case	Price /Case
IB783	862049	58 mm x 40 mm	700	30	289.00
IB784	862050	58 mm x 60 mm	500	30	289.00

DEFENDER™ 3000 PLATFORM SCALES

- Ideal for general weighing and simple counting applications in production, packaging, warehouse, inventory, shipping and receiving areas
- Ideal for bench and floor scale applications
- Indicator features a high-impact durable ABS housing with reversible rear cover for either wall, column or table-top mounting
- Large, backlit LCD display quickly displays results in a choice of multiple weighing units (lb., oz, combined lb:oz, kg or g)
- Parts counting mode with a minimum average piece weight of 1d, selectable sample sizes, and automatic retention of last sample size used and average piece weight data
- Built-in bidirectional RS232C for printing or connection to PC
- Includes an AC adapter and an internal rechargeable lead acid battery that lasts 100-hours between recharges
- Platform dimensions: 19.7" x 25.6" / 500 mm x 650 mm



IA555



NOT LEGAL FOR TRADE

Model No.	Mfg. No.	Capacity	Graduation	Price /Each
IA555	D31P150BX	300 lbs./150 kg	0.05 lbs./0.02 kg	1249.00
IA556	D31P300BX	600 lbs./300 kg	0.1 lbs./0.05 kg	1249.00

DEFENDER™ 7000 SQUARE BENCH SCALES

- ABS plastic indicator with square painted steel base
- Advanced parts counting, dynamic animal weighing, percent weighing, display hold for large containers, check weighing, accumulation, lb., oz, lb:oz, g, kg, user-defined custom unit
- Full alphanumeric keypad, dual-line backlit LCD display and check weighing LEDs
- Includes second scale analog input for dual base operation
- Pressed square steel welded base design for rugged durability with painted column
- Includes: RS232 interface with GMP/GLP data output including date and time, and external analog base input
- Internal poser supply with universal line cord or six C batteries (80-hour battery life)



IA643



NOT LEGAL FOR TRADE

Model No.	Mfg. No.	Capacity	Graduation	Platform Dimensions L" x W" x H"	Price /Each
IA640	D71P10QR1	25 lbs./10 kg	0.002 lbs./0.001 kg	12 x 12 x 3.8	1825.00
IA641	D71P25QR1	50 lbs./25 kg	0.005 lbs./0.002 kg	12 x 12 x 3.8	1825.00
IA642	D71P50QL2	100 lbs./50 kg	0.01 lbs./0.005 kg	12 x 12 x 3.8	1998.00
IA643	D71P100QL2	250 lbs./100 kg	0.02 lbs./0.01 kg	12 x 12 x 3.8	1998.00
IA644	D71P250QX2	500 lbs./250 kg	0.05 lbs./0.02 kg	24 x 24 x 5	2913.00

CYCLONE BENCH AND PLATFORM SCALE

- Durable thick stainless steel platter allows for heavy loads without bending
- 2 scales in one - Dual range- always the right sensitivity no matter how light or heavy the load
- Back support - Ideal for weighing products in bags or that which require extra support.
- Post mounted indicator - Makes it easy to see the screen
- Three weighing modes: lb., kg, pcs
- Ideal for shipping, receiving, check weighing or counting
- Battery or adapter operated



NOT LEGAL FOR TRADE

Model No.	Capacity Range 1	Graduation Range 1	Capacity Range 2	Graduation Range 2	Price /Each
15-3/4" L x 19-7/10" W					
IB770	0-60 kg / 0-150 lbs.	20 g. / 0.05 lbs.	60-150 kg / 150-300 lbs.	50 g. / 0.1 lbs.	629.00
17-3/4" L x 23-3/5" W					
IB771	0-150 kg / 0-300 lbs.	50 g. / 0.1 lbs.	150-300 kg / 300-600 lbs.	100 g. / 0.2 lbs.	789.00

TOP GUN ELECTRONIC PLATFORM SCALES

- For use in dry environments and areas with low humidity
- Counting function (secondary)
- Hi/Target/Lo (check weighing)
- Accumulation function
- Removable stainless steel platter (1.2 mm gauge) 12" W x 18" D (30.5 x 45.7 cm)
- Built-in level
- Adjustable lockable anti-slip leveling feet
- Predefined capacity settings eliminate installation errors
- Mobile installation
- Choice of ABS or stainless steel indicators



IB011

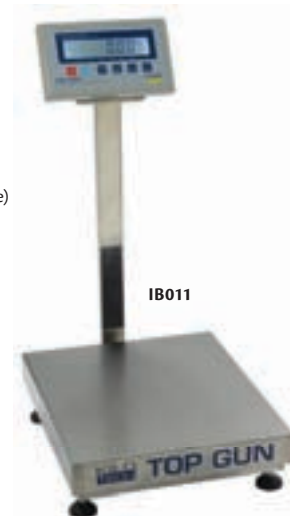

Model No.	Mfg. No.	Indicator*	Frame**	Capacity	Graduation	Price/Each
NOT LEGAL FOR TRADE						
IB011	KPLMS 1218-60	KIN 1000 (ABS)	MS	60 kg/150 lbs.	0.02 kg/0.05 lbs	862.00
IB012	KPLMS 1218-60	KIN 2000 (WR)	MS	60 kg/150 lbs.	0.02 kg/0.05 lbs	1142.00
IB013	KPLMS 1218-150	KIN 1000 (ABS)	MS	150 kg/300 lbs.	0.05 kg/0.1 lbs	876.00
IB014	KPLMS 1218-150	KIN 2000 (WR)	MS	150 kg/300 lbs.	0.05 kg/0.1 lbs	1148.00
LEGAL FOR TRADE						
IB015	KPLMS 1218-60	KIN 1000 (ABS)	MS	60 kg/150 lbs.	0.02 kg/0.05 lbs	1035.00
IB016	KPLMS 1218-60	KIN 2000 (WR)	MS	60 kg/150 lbs.	0.02 kg/0.05 lbs	1316.00
IB017	KPLMS 1218-150	KIN 1000 (ABS)	MS	150 kg/300 lbs.	0.05 kg/0.1 lbs	1047.00
IB018	KPLMS 1218-150	KIN 2000 (WR)	MS	150 kg/300 lbs.	0.05 kg/0.1 lbs	1352.00

*Indicator
ABS = ABS Plastic
WR = Stainless Steel
** Frame
MS = Mild Steel

SCALES

INDUSTRIAL HANGING SCALES

- Cast aluminum scratch resistant body
- Clear shatter resistant face plate
- 7 1/2" Dia., kg and lbs. dial
- Heavy-duty welded steel shackle ring
- Large pointed J-hook
- 1-year warranty



IA545

KILOTECH
www.kilotech.com

NOT LEGAL FOR TRADE

Model No.	Mfg. No.	Capacity	Graduation	Price/Each
IA543	KHS-C360	125 lbs./60 kg	0.5 lbs./200 g	"249,00"
IA544	KHS-C3120	250 lbs./120 kg	1 lbs./500 g	"249,00"
IA545	KHS-C3250	540 lbs./250 kg	2 lbs./1000 g	"249,00"

MINI DIGITAL CRANE SCALES

Ideal for light industry, hunters, luggage, parcels etc.

This mini digital crane scale is versatile, reliable, accurate and easy to operate. A quality stainless steel load receptor and cast aluminum housing protect the scale. The combination of circuit and dedicated weighing load cells ensure a stable reading.

- Stainless steel load receptor
- Cast aluminum housing
- LCD screen viewable from 22'
- Tare, Hold, Unit (between kg and lb.), Zero
- Programmable auto-off, auto-zero, manual zero, backlight
- Removable hook for easy cleaning
- For use in a dry environment and areas of low humidity
- 1-year warranty



IA787

KILOTECH
www.kilotech.com

NOT LEGAL FOR TRADE

Model No.	Mfg. No.	Capacity	Graduation	Price/Each
IA784	KHS 200-30	60 lbs./30 kg	0.02 lbs./0.01 kg	"175,00"
IA785	KHS 200-60	120 lbs./60 kg	0.05 lbs./0.02 kg	"175,00"
IA786	KHS 200-150	300 lbs./150 kg	0.1 lbs./0.05 kg	"175,00"
IA787	KHS 200-300	600 lbs./300 kg	0.2 lbs./0.1 kg	"175,00"

VN SERIES ECONOMICAL FLOOR SCALES

The Ohaus VN Series of floor platforms and scales are the value solution to your dry weighing needs in industrial and commercial applications. Its high-quality construction is designed to minimize distortion under heavy loads, and ensures years of dependable performance. NTEP certification ensures consistent weighing results.

Standard features of the VN Series include:

- 5 mm/0.196" painted carbon steel weighing platform top plate with raised cross-hatch surface for added slip resistance
- Four NTEP-certified shear beam load cells protected to IP67
- Side-access NEMA 4X/IP65 dust and water protected stainless steel junction box with 16 1/2" indicator cable
- Carbon steel eyebolts attached to side of platform for easy lifting and positioning
- T31P indicator includes: Backlit LCD display with 1" high digits, lbs. and kg weighing units, counting mode for inventory applications, 16 1/2" indicator cable, wall bracket for easy mounting, 80-hour internal rechargeable battery and AC adapter



IA560

NOT LEGAL FOR TRADE

Model No.	Mfg. No.	Capacity	Graduation	Platform Size L" x W" x H"	Price/Each
IA560	VN31P5000L	5000 lbs./2500 kg	1 lbs./0.5 kg	48 x 48 x 3 1/2	2094.00
IA561	VN31P5000X	5000 lbs./2500 kg	1 lbs./0.5 kg	60 x 60 x 3 1/2	2446.00
IA562	80252565			Floor Ramp, 4 feet wide	958.00
IA563	80252566			Floor Ramp, 5 feet wide	1087.00



INDIVIDUAL TEST WEIGHTS

These individual test weights can be used to periodically verify your scale's readings.

Recommended for scales with a minimum division size of 1 g. The M1 test weights include a vendor statement of accuracy.

KILOTECH
www.kilotech.com

Model No.	Mfg. No.	Capacity	Description	Class	Tolerance	Price/Each
IA565	853555	100 g			±5 mg	62.20
IA566	853554	200 g	Cylindrical, stainless steel, packed in plastic	Class M1 (OIML R111) with statement of accuracy;	±10 mg	62.30
IA567	853553	500 g		non-traceable	±25 mg	104.00
IA568	853552	1 kg	screw cap container with cushioned interior		±50 mg	138.00
IA569	853551	2 kg			±100 mg	256.00
IA570	853550	5 kg			±250 mg	345.00
IA571	853556	20 kg	Grip handle, cast iron	Class M1 (OIML R111) with statement of accuracy; non-traceable	±1 g	204.00
IA572	853557	50 lbs.	Grip handle, cast iron	Class M1 (OIML R111) with statement of accuracy; non-traceable	±.0028 lb.	285.00



LIGHT INDUSTRIAL-DUTY AIR CIRCULATING FANS

- All-metal construction
- Fully enclosed 2-speed motor
- 6' SJT power cord
- Stem length for pedestal: 89-124 cm



Model No.	Description	HP	Voltage	CFM Max.	CFM Min.	Price /Each
OSCILLATING						
EA282	26" Pedestal	1/4	120	7525	4050	405.00
EA283	30" Pedestal	1/3	120	8778	6780	420.00
EA284	26" Wall Mount	1/4	120	7525	4050	327.00
NON-OSCILLATING						
EA571	30" Pedestal	1/3	120	8400	6650	392.00

HEAVY-DUTY INDUSTRIAL AIR CIRCULATING FANS

- 115 V, 1/3 HP, 1 phase, 3 speed, totally enclosed air over ball bearing motor
- Patented modular motor end dome for easy maintenance
- Oscillating and non-oscillating
- Energy efficient - lowest watts per CFM
- Ultra quiet die cast aluminium airfoil propeller
- Wall and I-beam mounts able to be installed by one individual
- Includes: Cord and plug
- Meets OSHA standards

5-YEAR WARRANTY



Model No.	Description	F.L. Amps	High	CFM Med	Low	High	RPM Med	Low	Wt. lbs.	Price /Each
OSCILLATING										
EA353	24" Pedestal	2.5	5387	4356	3125	1070	850	628	89	1565.00
EA355	30" Pedestal	2.6	7996	5859	4063	1045	789	561	95	1615.00
EA354	24" Wall Mount	2.5	5387	4356	3125	1070	850	628	60	1425.00
EA356	30" Wall Mount	2.6	7996	5859	4063	1045	789	561	64	1505.00
NON-OSCILLATING										
EA349	24" Pedestal	2.5	5588	4556	3325	1110	900	700	85	991.00
EA351	30" Pedestal	2.8	8402	6259	4463	1098	880	660	87	1062.00
EA350	24" Wall Mount	2.5	5588	4556	3325	1110	900	700	56	886.00
EA352	30" Wall Mount	2.8	8402	6259	4463	1098	880	660	60	955.00

Note: Performance Ratings are conducted in accordance with AMCA Standard 230-99

INDUSTRIAL-DUTY AIR CIRCULATING FANS

- All-metal construction
- Fully enclosed motor
- 6' SJT power cord
- Stem length for pedestal: 89-124 cm



Model No.	Description	HP	Voltage	CFM Max.	CFM Min.	No. of Speeds	Price /Each
OSCILLATING							
EA645	24" Wall Mount	1/4	120	9200	7680	2	427.00
EA649	30" Wall Mount	1/4	120	10560	7760	2	459.00
EA643*	24" Pedestal	1/4	120	11040	7760	2	439.00
EA647*	30" Pedestal	1/3	120	10200	6700	2	565.00
NON-OSCILLATING							
EA644	24" Wall Mount	1/4	120	9200	7680	2	375.00
EA648	30" Wall Mount	1/4	120	9500	7440	2	407.00
EA642*	24" Pedestal	1/4	120	11040	7760	2	399.00
EA646*	30" Pedestal	1/4	120	9500	7440	3	428.00

*Features adjustable height and a heavy-duty round base for added stability

24" ROLL-ABOUT AIR FANS

- 120V, 1/5 HP, 3 speed motor
- Cart mounted fan for increased air circulation and optimal mobility
- Can be tilted/ positioned to maximise ventilation
- Cart and frame configuration provide stable quiet operation
- CFM: 8550 (high), 7770 (medium), 7040 (low)

Model No. EA476
Price/Each \$367.00



CATALOGUE PRICING

The prices shown in this catalogue are for "REFERENCE AND BUDGET PURPOSES ONLY" as of July 2016, and should be used exclusively as a guideline.

SPECIAL ORDERS

This catalogue represents only a portion of the products that are available to you. If you can't find what you need, please call us!

STAINLESS STEEL FOOD SERVICE WASHDOWN AIR CIRCULATING FANS

- Designed to withstand moist/wet environments, high pressure cleaning with concentrated caustic solutions without affecting performance or function
- Constructed with electro-polished 304 stainless steel
- All stainless steel motor
- Non-oscillating, 1 phase, totally enclosed non-vented ball bearing
- BISSC approved motor
- Motor washdown specification is IEC-IP55
- Available in non-adjustable pedestal or wall mount
- Safety cable kit is included in all overhead mounted air circulators
- Meets the USDA and the NSF for food zones
- 10-year warranty

Model No.	Description	Voltage	HP	CFM	RPM	Wt. lbs.	Price /Each
EA339	20" Pedestal	115 V	1/15	2670	1600	69	2430.00
EA341	24" Pedestal	115/230 V	1/4	5220	1075	79	2919.00
EA343	30" Pedestal	115/230 V	1/3	8800	1075	81	3215.00
EA340	20" Wall mount	115 V	1/15	2670	1600	52	2187.00
EA342	24" Wall mount	115/230 V	1/4	5220	1075	62	2520.00
EA344	30" Wall mount	115/230 V	1/3	8800	1075	64	2893.00



 **Airmaster® Fan Company**

CHEMICAL RESISTANCE RATING CHART

Chemical	Concentration	Stainless Steel Part
WATER		
De-ionized boiling	100%	Excellent
Salt (immersed)	30%	Excellent
Salt (spray)	5%	Excellent
Tap - 250 °F/120 °C @ 10 000 psi	100%	Excellent
ACIDS		
Hydrochloric	35%	Poor
Sulfuric	25%	Poor
Nitric	35%	Excellent
Picric	Saturated solution	Excellent
BASE		
Caustic	100%	Excellent
Caustic	12 pH	Excellent
Caustic - 125°F/50°C	9.5 pH	Excellent
SOLVENTS		
	-	Excellent

Notes: Performance ratings are conducted in accordance with AMCA Standard 230-99. When assembling fans, use only the stainless steel fasteners supplied with the motors. Fans and motors should be cleaned and inspected regularly. Cord and plug not provided. Must be hard wired. Wiring must conform to all national, provincial and local codes.

CEILING FANS

- A major source of untapped energy is available at the ceiling in most industrial and commercial buildings
- Air stratification causes heat build-up at the ceiling as much as 25 °F or more above floor level temperatures
- By installing ceiling fans, this warm air can be recirculated down to floor level to maintain a uniform air temperature from floor to ceiling
- The result saving can be as much as 30 %
- Electro-static white paint
- When ceiling fans are used for cooling people during the summer, they should be spaced 15' to 20' apart in the occupied area
- In warehouse storage areas, best results will be obtained if fans are mounted over aisle ways
- Fans should not be mounted less than 10' above the floor, the use of a safety cable is required on all ceiling fans

MARK I

- 1-year commercial warranty

MARK VI

- 2-year commercial warranty

JETPROOF

- Moisture and dust resistant
- Preassembled with watertight power cord and safety cable
- 2-year commercial warranty

 **Airmaster® Fan Company**

Model No.	Blade Size"	Fan Style	Down Length"	CFM	RPM	Voltage	Amps	Watts Full Speed	Wt. lbs.	Price /Each
EA357	56	Mark I	30/15	26 400	290	120	0.52	62	15	139.00
EA358	56	Mark VI	32/14	32 900	311	120	1.12	120	17	268.00
EA359	56	Mark VI	30/15	39 600	320	277	1.2	125	16	298.00
EA362	56	Jetproof (JP-CP)	24	32 900	311	115	1.12	120	16	421.00

Note: Safety cable included. Cord and plug not provided, must be hard wired, wiring must conform to all national, state and local code (except EA362).

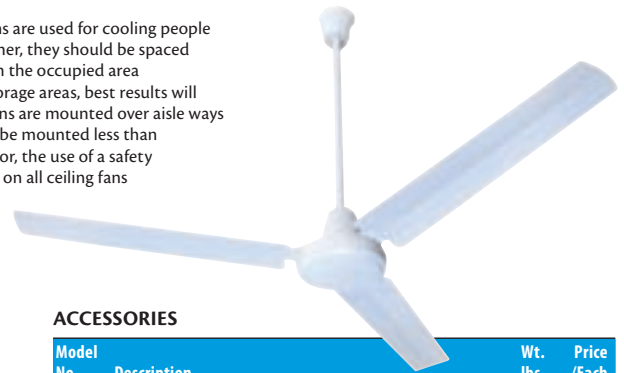

ACCESSORIES

Model No.	Description	Wt. lbs.	Price /Each
CONTROLS FOR CEILING FANS			
EA363	Variable speed control regulates 1 to 6 fans. Not to exceed a maximum amp draw of 6 amps	1	82.30
EA364	Variable speed control regulates 7 to 12 fans. Not to exceed a maximum amp draw of 10 amps	1	169.00
EA365	Variable speed control, 277 V, regulates 1 to 3 fans. 1.5 Amps	1	85.70
GUARD KIT FOR 56" FANS			
EA366	61" dia. nickel chrome plated top and bottom protective guard kit	21	412.00

THERMOSTAT PROTECTORS

- Molded of 1/8" thick, heavy-duty polycarbonate
- Offer excellent protection against tampering, abuse and accidental damage without affecting operation of thermostat or sensor
- Holes in the frame allow air to circulate freely
- Inner wall prevents tampering with dials and levers
- All thermostat covers have a key lock assembly
- Easy and quick installation
- Available for flush and surface mount applications (with use of spacer)
- Spacer adds 2" in depth and can mount around existing conduit
- Thick polycarbonate cover is backed by a lifetime guarantee against damage in normal use
- Polycarbonate rated -40°F (-40°C) to 120°F (49°C)

Model No.	Mfg. No.	Description	Colour	Size W" x D" x H"	Price /Each
SAN648	STI-9110	Thermostat Protector, Large	Clear	8.5 x 3.62 x 5.37	71.90
SAN649	STI-9105	Thermostat Protector, Small	Clear	5.5 x 3 x 4.62	55.00
SAN650	STI-9105-S	Thermostat Protector, Small	Smoke	5.5 x 3 x 4.62	59.20
SAN651	SUB-901	Spacer for SAN649 and SAN650	Clear	5.5 x 2 x 5	32.10



 **Safety Technology International, Inc.**



6" CLIP-ON & DESK FANS

- 2-speed, low and high settings
- Tilting head
- Fully assembled and ready for use
- Convertible clip and desk feature
- Weight: 2.21 lbs.

Model No. EA304
Price/Each \$27.25

Convertible
Clip Included



OSCILLATING DESK FANS WITH PUSH BUTTONS

- 3-speed push buttons controls
- Rotating or fixed air direction
- Portable and easy to assemble
- Topples resistant base



Model No.	Dia. "	Wt. lbs.	Price /Each
EA305	12	5.5	50.00
EA306	16	6.83	60.80



16" WALL MOUNT OSCILLATING FANS

- 3-speed control with timer and remote
- Rotating or fixed air direction
- Easy to assemble
- Weight: 8.82 lbs.

Model No. EA526
Price/Each \$97.30



20" BOX FANS

- 3-speed control
- Five slim blades
- Fully assembled and ready to use
- Weight: 9.92 lbs.

Model No. EA527
Price/Each \$66.70



18" OSCILLATING PEDESTAL FANS

- 3-speed push button front control
- Adjustable height
- Rotating or fixed air direction
- Easy to assemble
- Weight: 19.84 lbs.

Model No. EA551
Price/Each \$79.70



HIGH VELOCITY FLOOR FANS

- 120 V/60 Hz, 1/4 HP, 3-speed motor
- All metal construction, chrome grill and base

EA290



Model No.	Diameter"	High	CFM Med	Low	Wt. lbs.	Price /Each
EA528	16	2370	1950	1560	10	95.70
EA290	18	4725	3850	2975	16.18	134.00

20" HIGH VELOCITY PEDESTAL FANS

- 120 V/60 Hz, 1/4 HP, 3-speed motor
- All-metal construction, chrome grill, black painted base
- Adjustable pedestal base
- 6' SJT power cord
- CFM: 5950 high, 4550 medium, 3850 low
- Overall height: 134-157.5 cm
- Base dia.: 48.5 cm
- Stem length: 63-86.5 cm
- Weight: 36 lbs.

Model No. EA289
Price/Each \$249.00



18" CART MOUNTED FANS

- 115 V, 1/8 HP, 1 phase, 3-speed, open drip proof, ball bearing motor
- Adjusts on 360°
- Nickel chrome guards meet OSHA regulations
- Four-position easy reach switch with 10' three-conductor cord and plug
- Aluminum propellers
- 4" casters
- CFM: 2966 high, 2437 medium, 2013 low
- RPM: 1600 high, 1350 medium, 1180 low
- Weight: 23 lbs.
- 1-year warranty

Model No. EA335
Price/Each \$252.00



Airmaster® Fan Company

HVAC

ELECTRONIC WINDOW HORIZONTAL AIR CONDITIONERS

- 3-speed fan
- Programmable thermostat
- 24-hour programmable timer
- Energy saver mode and sleep mode
- 4-way directional louvers
- One touch lift washable/reusable filter
- Remote control
- Aluminum fins with protective coat
- Compressor start-stop protection



Model No.	BTU Rating	Dimensions				Wt. lbs.	Price /Each
		W"	x D"	x H"	x H"		
EA081	8000	18 19/32	x 15 23/32	x 12 3/4	51	418.00	
EA235	10000	19 1/32	x 21 1/4	x 14 9/16	77	482.00	

AIR PURIFIERS

- Reduces smoke, dust, pollen and other particles
- Independent ioniser to assist with particle removal
- Quiet 3-speed fan with high quality motor
- Washable pre-filter
- Filters included



EA585



Model No.	Description	Room Size sq.ft.	Price /Each
EA585	Tower	180	89.00
REPLACEMENT FILTERS FOR EA122			
Model No.	Type		Price/Each
EA127	Filter cartridge, 2/pkg.	-	23.60

99.97% HEPA AIR PURIFIERS

- Effectively removes up to 99.97% of airborne particulate pollutants as small as 0.3 microns such as dust, pollen, smoke, mould spores and pet dander from air passing through the filter
- Digital control
- Space saving design can be placed upright or on side
- Carbon filter enhanced with baking soda to absorb and eliminate odours
- Filter service check - reminds you when it's time to clean the filter
- Timer
- CADR smoke 168, dust 174 and pollen 140



Model No.	Recommended Room Size sq.ft.	Price /Each
EA554	256	181.00
REPLACEMENT FILTERS		
Model No.	Type	Price/Each
BB243	HEPA filter	61.30
BB226	Carbon filter	17.30

MOBILE 3 IN 1 AIR CONDITIONERS

- 3-speed fan
- Can be used as and air conditioner, a dehumidifier or a fan
- Programmable thermostat
- 24-hour programmable timer
- Sleep and auto mode
- Independent dehumidifying system shut down when tank is full

Model No. EA600 8000 BTU
Price/Each \$564.00



DEHUMIDIFIERS

- Water bucket full indicator
- Portable unit on casters allows for easy movement of the unit
- Electronic controls with LED display
- Timer feature
- Clean filter reminder with LED indicator
- External drain connector
- Automatic defrost



Model No.	Capacity Pints	Coverage sq.ft.	Dimensions			Wt. lbs.	Price /Each
			W"	x D"	x H"		
EA567	30	2000	20 7/8	x 16	x 13	34	329.00
EA568	45	2500	20 7/8	x 16	x 13	35.3	394.00
EA569	50	3000	25 3/4	x 17 1/3	x 13 2/3	53	356.00
EA570	70	4000	25 3/4	x 17 1/3	x 13 2/3	54	468.00

SUNBEAM® WHOLE HOUSE COOL MIST HUMIDIFIER

- Humidifies up to 1800 sq. ft.
- 5-gal. capacity
- Up to 24-hour run time per tank filling with auto shut-off
- Triple layer filter enhanced with Arm & Hammer™ Baking Soda
- Adjustable humidistat
- 2-speed settings
- Antimicrobial Product Protection is infused into the plastic to help prevent the growth of bacteria that can cause stains and odors or adversely affect performance
- Removable, flat tank for easy filling and cleaning

Model No. EA613
Mfg. No. SCM3755-CN
Price/Each \$135.00



SMOKE EJECTORS

Remove smoke, welding fumes and undesirable contaminants from the air or bring clean air in. Reversible smoke ejectors are equipped with a totally enclosed ball bearing motor with automatic overload protection. Units are CSA approved. Explosion-proof models in accordance with Class 1 Group D/ Class II Group EFG. All are 115 VAC, 1/3 HP, 1725 RPM equipped with a 6' power cord, cord holder and cadmium plated protection guards. Hoses are fire safe single ply neoprene impregnated nylon.

Model No.	Type	CFM @ 0.10" SP	Box Dim.			Fan Size"	Price /Each		
			L"	x	W"	x	H"		
BA099	Standard	1620	17	x	14 1/8	x	14 1/8	12	938.00
BA101	Standard	3151	17	x	19 1/8	x	19 1/8	16	1086.00
BA103	Standard	3700	17	x	21 3/8	x	21 3/8	18	1063.00
BA102	Exp. Proof	3151	17	x	19 1/8	x	19 1/8	16	2420.00
BA104	Exp. Proof	3700	17	x	21 3/8	x	21 3/8	18	2396.00



COLLAR ADAPTORS

Model No.	Fan Size"	Price /Each
BA026	12	158.00
BA028	16	180.00
BA029	18	205.00

FLEXIBLE HOSES

Model No.	Length'	Dia."	Price /Each
BA049	15	12	188.00
BA050	20	16	234.00
BA051	20	18	281.00

SHUTTER FANS

- 115 V motor 1 phase
- Totally enclosed motor
- Direct drive, low pressure
- Fully assembled, ready to install
- Rear guard meets OSHA standards
- 24" and 30" : 3 speeds with pull chain motor, plug and cord included

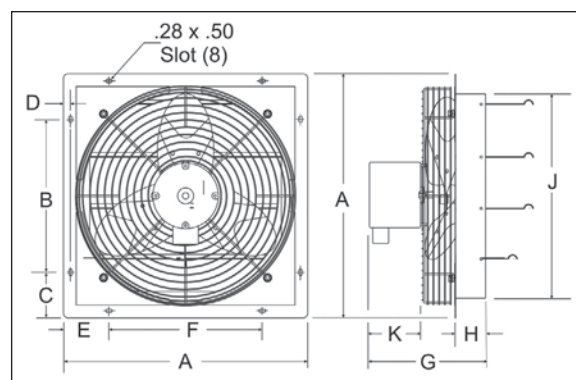

Airmaster® Fan Company

Model No.	Fan Dia."	CV	0" S.P. CFM	1/8" S.P. CFM	A"	B"	F"	Dimensions			Panel Size (square)	Wall Opening (square)	Weight lbs.	Price /Each	
								G"	H"	J"	K"				
EA368	7	1/30	121	60	11.1	4	4	8.06	2.38	8	3	11 1/8"	8 1/2"	10	335.00
EA369	10	1/30	611	318	13.1	6	6	8.06	2.38	10	3	13 1/8"	10 1/2"	10	287.00
EA370	12	1/30	815	490	15.1	8	8	8.06	2.38	12	3	15 1/8"	13"	12	327.00
EA371	16	1/20	1216	765	19.1	12	12	9.06	2.38	16	4	19 1/8"	17"	20	490.00
EA372	18	1/15	1877	752	21.1	14	14	11	2.5	18	4.8	21 1/8"	18 1/2"	25	546.00
EA373	20	1/15	2235	920	23.1	16	16	11	2.5	20	4.8	23 1/8"	20 1/2"	35	581.00
EA374	24	1/4	3214	2015	27.1	20	20	12.7	3	24	5	27 1/8"	25"	48	684.00
EA375	30	1/4	4970	3510	33.1	26	26	12.7	3	30	5	33 1/8"	30 1/2"	57	1020.00

ALL PURPOSE WALL FANS

- 115 V motor
- Direct drive, low pressure
- Totally enclosed sleeve bearing motors
- Non-overloading propeller
- High efficiency, low operating cost
- Built-in rear guard
- Commercial-duty
- Four holes 0.38" dia.

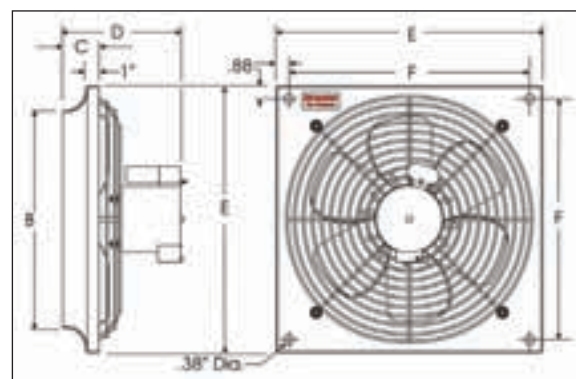

Airmaster® Fan Company

Model No.	Fan Dia."	HP	RPM	0"	Capacity (CFM) @ SP In. W.G.					Dimensions					Weight lbs.	Price /Each	
					0.05"	0.10"	0.125"	0.20"	0.250"	A"	B"	C"	D"	E"			F"
EA376	10	1/30	1550	630	469	418	394	309	234	10	10 1/4	11/2	6	14	12.3	12	559.00
EA377	12	1/30	1550	897	843	754	689	503	378	12	12 1/4	11/2	8	16	14.3	14	582.00
EA378	16	1/9	1050	1881	1766	1626	1540	1169	814	16	16 1/2	1 3/4	9 1/2	20	18.3	24	706.00
EA379	18	1/9	1050	2504	2345	2149	2035	1553	884	18	18 1/2	1 3/4	10	22	20.3	27	750.00

LIGHT INDUSTRIAL DIRECT DRIVE DRUM FANS

- 120 V/60 Hz, 2-speed motor
- All-metal construction, painted black
- 6' SJT power cord
- 6" casters and easy moving handle



Model No.	Blade size"	HP	Watts	CFM		Wt. lbs.	Price /Each
				High	Low		
EA286	28	2/5	290	8050	6500	22	493.00
EA288	36	3/5	405	11200	9100	30.5	604.00

24" DIRECT DRIVE DRUM FANS

- 115 V, 1/4 HP, 2-speed, 1-phase, ball bearing motor
- 3-bladed galvanized steel propellers
- 2-speed rocker switch
- Epoxy coated barrel and steel resilient mounted guards
- Two steel wheels with rubber tires
- Handle with cord wrap for 10' cord with three-prong plug
- Tilttable
- CFM: 4000 (high), 2100 (low)
- RPM: 1100 (high), 800 (low)
- Weight: 70 lbs.

Model No. EA338
Price/Each \$513.00



2-YEAR WARRANTY



36" BELT DRIVE DRUM FANS

- 115 V, 1/2 HP, 2-speed, 1-phase, ball bearing motor
- 3-bladed aluminum propellers
- 2-speed rocker switch
- Epoxy coated barrel and steel resilient mounted guards
- Steel wheels with rubber tires
- Easy grip handle with cord wrap
- 10' cord with three-prong plug
- Tilttable
- CFM: 7800 (high), 5300 (low)
- RPM: 660 (high), 450 (low)
- Weight: 116 lbs.

Model No. EA318
Price/Each \$801.00



2-YEAR WARRANTY



42" BELT DRIVE DRUM FANS

- 115 V, 1 HP, 2-speed, 1-phase, ball bearing motor
- Motor out of air stream – stays clean
- Aluminum 4-bladed propellers
- Rocker switch
- Epoxy coated steel spiral, resilient mount guards
- Steel hubbed wheels, swivel locking casters
- 20-gauge roll form epoxy coated housing
- 10' three-conductor cord and plug
- CFM: 17 100 (high), 9558 (low)
- RPM: 430 (high), 285 (low)
- Quiet operation: 75 dB (high), 67 dB (low)
- Weight: 130 lbs.

Model No. EA319
Price/Each \$1079.00



2-YEAR WARRANTY



48" BELT DRIVE DRUM FANS

- 115 V, 1 HP, 1 speed, 1 phase, ball bearing motor
- 4-bladed steel propellers
- Epoxy coated steel spiral, resilient mount guards
- Steel wheels with rubber tires
- Front leg bracket, pull handle
- 12' three-conductor SJT type cord with switch
- CFM: 17 173
- RPM: 385
- Weight: 165 lbs.
- Comes fully assembled

Model No. EA320
Price/Each \$2017.00



2-YEAR WARRANTY



DIRECT DRIVE 4-IN-1® DRUM FANS

- 115 V, 1 phase, ball bearing motor
- One fan with four mounting options in the same carton: Hanging mount, ceiling mount, wall mount, portable barrel
- Guards, barrel mountings epoxy coated
- Pull chain switch
- Tilttable

2-YEAR WARRANTY



Model No.	Blade Size"	HP	# of Speeds	CFM			RPM		Wt. lbs.	Price /Each	
				High	Med	Low	High	Med			Low
EA336	30	1/4	3	5670	4590	3410	1110	810	600	97	720.00
EA337	36	1/2	2	11200	-	8090	830	-	600	119	863.00

PORTABLE FAN-FORCED UTILITY HEATERS

- Two heat settings (1300 W and 1500 W) provide full comfort and economic operation
- Adjustable thermostat
- Fan-only setting
- Tip over safety switch
- Built-in carrying handle with front safety guards



Model No.	Volts	Watts	BTU/H	Amps	Price /Each
EA598	120	1300/1500	4435/5120	10.8/12.5	80.25

PORTABLE OPEN COIL HEATERS

- Two heat settings (1500 W and 1000 W)
- Provide full comfort and efficient operation
- Fully adjustable automatic thermostat
- Safety overload switch
- Power signal light
- Top mounted handle and controls
- Grounded plug and controls



Model No.	Volts	BTU/H	Watts	Amps	Price /Each
EA469	120	3410/5120	1000/1500	8.3/12.5	77.95

PORTABLE FAN-FORCED CONVECTION HEATERS

- Two heat settings (1500W and 750W) provide full comfort and efficient operation
- Adjustable thermostat
- Wide-angle oscillation
- Tip over safety switch and thermal limit control



Model No.	Volts	Watts	BTU/H	Amps	Price /Each
EA597	120	750/1500	2560/5200	6.25/12.5	46.30

PORTABLE FAN-FORCED/RADIANT UTILITY HEATERS

- Three heat settings provides full comfort and efficient operation
- 600 W radiant
- 900 W fan forced
- 1500 W fan forced and radiant
- Chrome-plated safety grill
- Automatic built-in thermostat
- Ceramic core element
- Tip over safety switch and thermal limit



Model No.	Volts	Watts	BTU/H	Amps	Price /Each
EA466	120	600/900/1500	2048/3072/5120	5.0/7.5/12.5	136.00

PORTABLE CERAMIC HEATERS

- Two heat settings (1500 W and 750 W) provide full comfort and efficient operation
- Adjustable thermostat
- PTC heating element
- Tip over safety switch and thermal safety fuse



Model No.	Volts	Watts	BTU/H	Amps	Price /Each
EA599	120	750/1500	2560/5200	6.25/12.5	66.50

OIL-FILLED HEATERS

- 7-fin, oil-filled heater
- Three heat settings provide full comfort and efficient operation
- Adjustable thermostat
- Built-in over heating protection



Model No.	Volts	Watts	BTU/H	Amps	Price /Each
EA612	120	1500	5120	12.5	86.85

CONTRACTOR HEATERS

- Built-in thermostat
- Safety high temperature limit
- Steel spiral fin brazed to metal sheath elements for maximum heat transfer
- 6' heavy-duty cord
- Built-in handle/cord storage
- Permanently lubricated motor



Model No.	Volts	PH	Watts	BTU/H	Amps	Plug Type	Wt. lbs.	Price /Each
EA477	240	1	5600	19 110	23.34	#6-30P	12	209.00
EA561	240	1	4800	16380	20	#6-30P	12	143.00

PORTABLE CERAMIC HEATER

- Two heat settings (1500 W and 900 W) provide full comfort and efficient operation
- Adjustable thermostat
- Big carry handle
- Type: Ceramic
- Power Source: Electric



Model No.	Volts	BTU Rating Min	BTU Rating Max	Price /Each
EA650	120	2560	5200	82.35

PORTABLE UNDER DESK RADIANT HEATER

- Two heat settings: High or Low
- Thin and lightweight
- Includes fold-out metal floor stand
- Type: Radiant Heat
- Power Source: Electric
- Voltage: 120 V
- BTU Rating: 580 BTU/H

Model No. EA651
Price/Each \$105.00



HEAVY-DUTY CEILING MOUNT HEATERS

- Rugged heavy-duty industrial heaters
- Ideal for use in barns, storage rooms, workshops, garages, warehousing
- Built-in ceiling bracket for easy mounting
- Automatic fan delay
- 240 V



Model No.	Max. BTU Rating	Max. Wattage:	Motor	Price /Each
EA532	17,060 BTU/H	5000 W	Open	260.00
EA652	25,600 BTU/H	7500 W	Enclosed	425.00

PORTABLE ELECTRIC BLOWER HEATERS

- Heavy-duty fin-tube metal heating element
- Fan-only operation for summer cooling
- Safe to operate in unattended areas
- Shipped fully assembled
- 240 V, 10 kW, 41.7 A, 32 120 BTU/H

Note: for indoor use only with ceiling heights of 15' or less

Model No. EA101
Price/Each \$926.00



Area Size sq.ft.	Temperature Rise	
	10°C	19°C
1000	70 min	140 min
1500	105 min	210 min

FAN-FORCED ZONAL WALL HEATERS

- Built-in thermostat
- European styling: sleek rounded corners
- Dual protection: thermal cutout with indicator light and one time thermal fuse
- Fast coil response element assures quick heat and low maintenance



Model No.	Volts	Watts	Amps	BTU/H	Price /Each
EA030	120	1500/1120/750/375	12.5/9.4/6.3/3.1	5118/3838/2560/1280	202.00
EA031	240	2000/1500/1000/500	8.3/6.3/4.2/2.1	6824/5118/3412/1706	168.00
	208	1500/1125/750/375	12.5/9.4/6.3/3.1	5118/3838/2560/1280	

SUN BLAST® HEATERS

- Efficient, heats radiantly, directly, no loss of heat to the air
- Economical, no electricity required
- Fits on a standard 20 lb. LP cylinder
- Variable BTU output
- Manual ignition
- Front and back protective grill
- No assembly required
- Heater shuts off automatically with loss of flame
- Natural gas version also available



Model No.	Mfg. No.	Description	Rating BTU/H		Price /Each
			Min.	Max.	
JG966	SUN BLAST 15	Single Tank-Top Radiant Heater	9000	15000	80.60
JG967	SUN BLAST 30	Double Tank-Top Radiant Heater	9000	30000	171.00



TRADESMAN™ FORCED AIR PROPANE HEATERS

- Tradesman® forced air heaters feature a unique 3-trial ignition system, the industry's heaviest gauge combustion chamber and burner plate
- Variable output control for maximized fuel efficiency
- Electronic spark ignition
- Thermostatic temperature control
- Tri-Shield finish provides protection against abrasion and corrosion
- Adjustable front leg provides easy direction of heat
- 15' hose
- Voltage: 115 V



JG953



JG954

Model No.	Mfg. No.	Amperage (Starting/Continuous Operation)	Wattage (Starting/Continuous Operation)	BTU Rating	Price /Each
JG953	TRADESMAN 170	3.7/2.4	425.5/241.5	125 000 to 170 000	658.00
JG954	TRADESMAN 400	4.0/1.5	460/172.5	240 000 to 400 000	1074.00

TRADESMAN™ FORCED AIR KEROSENE HEATERS

- Tradesman® kerosene heaters provide instant, efficient, directional heat
- A dependable dual-prong electronic spark ignition, heavy-duty enclosed motor and long lasting composite fuel fittings are just a few of the features that provide long life and trouble free operation
- Dual-prong electronic spark ignition
- Auxiliary 110 V power receptacle
- Temperature display and thermostat
- Fuel gauge indicates remaining run time
- Threaded drain plug
- Wheels and handles make it easier to maneuver (JG958, JG959, JG960 only)
- Includes pressure gauge (JG958, JG959, JG960 only)
- Voltage: 115 V



JG957



JG958

Model No.	Mfg. No.	Amperage (Continuous Operation)	Wattage (Continuous Operation)	BTU Rating	Tank Capacity US Gallons	Price /Each
JG957	TRADESMAN K75	1.6	184	75 000	5	484.00
JG958	TRADESMAN K125	2.5	287.5	125 000	10	698.00
JG959	TRADESMAN K175	3.2	368	175 000	13	773.00
JG960	TRADESMAN K210	3.7	425.5	210 000	13	925.00

PREMIER™ FORCED AIR KEROSENE HEATER

- Premier™ heaters are ideal for small or large work spaces, renovation jobs, and any applications where low noise or an enclosed flame is important
- Can be used to provide heat or simple air circulation inside or be ducted in from the outside
- Quiet operation
- Can be used with or without ducting
- Dependable electronic spark ignition
- Tri-Shield finish provides protection against abrasion and corrosion
- 15' hose and regulator included
- 20' remote start thermostat
- Vent mode for circulation of air
- Easy to transport
- Voltage: 115 V



Model No.	Mfg. No.	Amperage (Starting/Continuous Operation)	Wattage (Starting/Continuous Operation)	BTU Rating	Price /Each
JG963	PREMIER 80	5.0/1.5	575/172.5	80 000	2371.00

SUN BLAST® FLAT PANEL RADIANT HEATER

- Sun Blast® flat panel is great for spot heating large areas
- Folding handle and wheels for easy transport
- Piezo pilot ignition
- Tip over switch shuts product down for safety
- Works with standard 20 lb. cylinder
- Lightweight for easy maneuverability
- Directional heating
- Natural gas version also available



Model No.	Mfg. No.	Rating BTU/H	Price /Each
JG968	SUN BLAST 35	35 000	273.00

SUN BLAST® RADIANT HEATER

- Sun Blast® round provides 360° radiant heating
- High handle and wheels for easy transport
- Durable rugged construction ideal for any construction site
- Piezo pilot ignition
- Tip over switch shuts product down for safety
- Natural gas version also available



Model No.	Mfg. No.	Rating BTU/H	Price /Each
JG969	SUN BLAST 125	125 000	445.00

30/30® HIGH-CAPACITY PLEATED PANEL FILTERS

Features and benefits:

- High capacity pleated panel filter available in 1", 2" or 4" depths
- A welded wire grid to maintain the radial pleat and eliminates distortion of the media pack even under turbulent or high airflow conditions
- Exclusive MERV 8 Media, blended from cotton and polyester fibres, providing consistent dirt removal efficiency throughout the life of the filter
- The 30/30 meets today's medical facility requirements
- A low initial and maintained low resistance to airflow, over the life of the filter that saves energy dollars
- A high wet-strength beverage board frame for maintained filter rigidity in any application
- Maximum continuous operating temperature of 200°F (93°C)
- Proprietary blend of cotton and synthetic fibres in a uniform lofted media blanket

Efficiency: Value of 8 for MERV and MERV-A when evaluated under ASHRAE Testing Standard 52.2.

Typical applications: Pre-filters to higher efficiency filters, stand-alone filter for rooftops, split systems, free-standing units and package systems and air handlers. Ideal for commercial, industrial, institutional or any other application where the ultimate level of protection of equipment and indoor air quality is a concern.



Model No.	Nominal Size					Actual Size					CFM		Resistance*		Media Area sq.ft.	Pleats /foot	Price /Each
	W"	x	D"	x	H"	W"	x	D"	x	H"	Medium	High	Medium	High			
EA157	16	x	4	x	20	15.38	x	3.75	x	19.38	550	1100	0.07	0.27	15.7	11	18.40
EA158	20	x	4	x	20	19.38	x	3.75	x	19.38	695	1390	0.07	0.27	18.9	11	20.00
EA159	12	x	4	x	24	11.38	x	3.75	x	23.38	500	1000	0.07	0.27	13.9	11	16.10
EA160	24	x	4	x	24	23.38	x	3.75	x	23.38	1000	2000	0.07	0.27	27.7	11	27.00
EA161	16	x	4	x	25	15.38	x	3.75	x	24.38	695	1390	0.07	0.27	19.7	11	22.10
EA162	20	x	4	x	25	19.38	x	3.75	x	24.38	870	1740	0.07	0.27	23.6	11	24.30
EA163	16	x	2	x	20	15.5	x	1.75	x	19.5	550	1100	0.08	0.28	9.9	15	10.60
EA164	20	x	2	x	20	19.5	x	1.75	x	19.5	695	1390	0.08	0.28	11.9	15	11.70
EA165	12	x	2	x	24	11.38	x	1.75	x	23.38	500	1000	0.08	0.28	8.4	15	9.44
EA166	24	x	2	x	24	23.38	x	1.75	x	23.38	1000	2000	0.08	0.28	17.3	15	16.00
EA167	16	x	2	x	25	15.5	x	1.75	x	24.5	695	1390	0.08	0.28	12.4	15	12.00
EA168	20	x	2	x	25	19.5	x	1.75	x	24.5	870	1740	0.08	0.28	14.9	15	13.30
EA169	12	x	1	x	24	11.5	x	0.88	x	23.5	350	700	0.11	0.25	4.9	16	8.56
EA170	16	x	1	x	20	15.5	x	0.88	x	19.5	390	780	0.11	0.25	5.4	16	7.87
EA171	20	x	1	x	20	19.5	x	0.88	x	19.5	485	970	0.11	0.25	6.6	16	9.01
EA172	24	x	1	x	24	23.5	x	0.88	x	23.5	700	1400	0.11	0.25	9.8	16	11.40
EA173	16	x	1	x	25	15.5	x	0.88	x	24.5	485	970	0.11	0.25	6.7	16	8.32
EA174	20	x	1	x	25	19.5	x	0.88	x	24.5	610	1220	0.11	0.25	8.3	16	10.60

*Initial resistance to airflow (inches w.g.)

Other sizes also available.

AEROPLEAT® III STANDARD CAPACITY PLEATED PANEL FILTERS

Features and benefits:

- Medium capacity pleated panel filter
- Optimum blend of cotton and synthetic fibres provides medium grade ASHRAE performance and increased dust-holding capacity
- Welded wire media grid is treated for corrosion resistance and prevents media oscillation or pull-away
- High wet-strength beverage board frame creates a rigid and durable filter pack
- Efficiency MERV 8 when evaluated per ASHRAE Standard 52.2-2007 and a MERV-A of 8 when evaluated under Appendix J of that Standard
- Applications include commercial buildings, educational facilities and specialty manufacturing
- As a pre-filter the AeroPleat III offers protection for the higher efficiency final filters required for today's high technology applications



Model No.	Nominal Size					Actual Size					CFM		Resistance*		Media Area sq.ft.	Pleats /foot	Price /Each
	W"	x	D"	x	H"	W"	x	D"	x	H"	Medium	High	Medium	High			
EA139	16	x	4	x	20	15.38	x	3.75	x	19.38	555	1110	0.07	0.21	12.6	9	13.60
EA140	20	x	4	x	20	19.38	x	3.75	x	19.38	695	1390	0.07	0.21	15.7	9	15.10
EA141	12	x	4	x	24	11.38	x	3.75	x	23.38	500	1000	0.07	0.21	11.3	9	10.90
EA142	24	x	4	x	24	23.38	x	3.75	x	23.38	1000	2000	0.07	0.21	22.7	9	18.30
EA143	16	x	4	x	25	15.38	x	3.75	x	24.38	695	1390	0.07	0.21	15.7	9	15.00
EA144	20	x	4	x	25	19.38	x	3.75	x	24.38	870	1740	0.07	0.21	19.7	9	16.40
EA145	16	x	2	x	20	15.5	x	1.75	x	19.5	555	1110	0.08	0.23	6.5	10	7.20
EA146	20	x	2	x	20	19.5	x	1.75	x	19.5	695	1390	0.08	0.23	8.6	10	8.86
EA147	12	x	2	x	24	11.38	x	1.75	x	23.38	500	1000	0.08	0.23	6.1	10	6.66
EA148	24	x	2	x	24	23.38	x	1.75	x	23.38	1000	2000	0.08	0.23	12.1	10	9.77
EA149	16	x	2	x	25	15.5	x	1.75	x	24.5	695	1390	0.08	0.23	7.8	10	8.92
EA150	20	x	2	x	25	19.5	x	1.75	x	24.5	870	1740	0.08	0.23	10.7	10	10.00
EA151	12	x	1	x	24	11.5	x	0.88	x	23.5	350	700	0.11	0.23	3.8	12	8.97
EA152	16	x	1	x	20	15.5	x	0.88	x	19.5	390	780	0.11	0.23	4.3	12	7.44
EA153	20	x	1	x	20	19.5	x	0.88	x	19.5	485	970	0.11	0.23	5.4	12	8.34
EA154	24	x	1	x	24	23.5	x	0.88	x	23.5	700	1400	0.11	0.23	7.8	12	11.30
EA155	16	x	1	x	25	15.5	x	0.88	x	24.5	485	970	0.11	0.23	5.4	12	9.31
EA156	20	x	1	x	25	19.5	x	0.88	x	24.5	610	1220	0.11	0.23	6.7	12	9.08

*Initial resistance to airflow (inches w.g.)

Other sizes also available.

FLASHLIGHTS & BATTERIES

ENERGIZER® BATTERIES

ALKALINE



XB872



XB875



XB876



XC001

SILVER OXIDE



XB992



XB944

LITHIUM



XC015



XC012



XC007



XC008



XE736

GARAGE DOOR



XB995

NIMH RECHARGEABLE



XC017



XC016



XC019



XC018

Model No.	Mfg. No.	Description	Qty /Pkg.	Price /Package
ALKALINE INDUSTRIAL				
XB873	EN92	AAA/1.5 V	24	19.10
XB872	EN91	AA/1.5 V	24	17.40
XB874	EN93	C/1.5 V	12	19.60
XB875	EN95	D/1.5 V	12	21.70
XB876	EN22	9 V	12	30.10
ALKALINE				
XC001	E96BP2	AAAA/1.5 V/ E2	2	6.93
XA430	529	Lantern, 6 V, Spring	1	14.80
XB996	A76BP2	1.5 V, Instruments	2	2.41
SILVER OXIDE				
XB992	357BP	1.5 V, 11,6 mm x 5,4 mm	1	1.81
XB993	377BP	1.5 V, 6,8 mm x 2,6 mm	1	2.81
XB994	392BP2	1.5 V, 7,9 mm x 3,6 mm	1	1.60
XB944	EPX76P2	1.55 V, 11,6 mm x 5,4 mm	1	1.89
LITHIUM				
XC002	ECR2016BP	Coin Type, 3 V, CR2016	1	3.45
XC003	ECR2025BP	Coin Type, 3 V, CR2025	1	3.45
XC004	ECR2032BP	Coin Type, 3 V, CR2032	1	1.81
XC005	ECR2450BP	Coin Type, 3 V, CR2450	1	4.35
XC006	EL123APBP	Photo, 3 V, 123	1	4.53
XC007	EL1CR2BP	Photo, 3 V, 1CR	1	16.60
XC008	EL223APBP	Photo, 6 V, 223	1	16.20
XC009	EL2CR5BP	Photo, 6 V, 2CR5	1	16.60
XE736	LS22BP	9 V	1	13.70
XC012	L91BP2	AA/1.5 V	2	9.75
XC013	L91BP4	AA/1.5 V	4	18.60
XC015	L92BP2	AAA/1.5 V	2	11.50
NIMH RECHARGEABLE				
XC016	NH12BP2	AAA	2	15.80
XC017	NH15BP4	AA	4	27.30
XC018	NH22NBP	9 V	1	19.90
XC019	NH35BP2	C	2	19.90
XC020	NH50BP2	D	2	19.90
GARAGE DOOR				
XB995	A23BP	12 V	1	3.35

ECO ADVANCED™ BATTERIES

- Made with 4% recycled batteries
- Holds power up to 12 years in storage
- Energizer's longest lasting alkaline battery



XE877

Model No.	Mfg. No.	Description	Qty /Pkg.	Price /Package
XE877	XR91BP12	AA/1.5 V	12	14.49
XE878	XR92BP8	AAA/1.5 V	8	14.49

BATTERY CHARGERS

XD153

- Charges two or four AA and AAA batteries
- Charge in your car with the included car adaptor or at home with the AC wall adaptor
- Easy-to-read charge status indicator light
- Includes four AA NIMH batteries
- Energy Star® certified



XD153

XE457

- Charges: AA, AAA
- Comes with four AA NIMH batteries
- Ideal for travelling and digital cameras
- Auto shut off
- Energy Star



XD021



XE457

XD021

- Charges two or four AA or AAA NiMH rechargeable batteries
- Easy-to-read charge status indicators
- Fold-out plug for easy storage
- Includes two AA NIMH batteries

Model No.	Mfg. No.	Description	Charge Time	Price /Each
XD153	CH15MNCP4	Wall and Car Charger	2 AA, 15 min - 4 AA, 30 min	87.10
XE457	CHPROWB4	Overnight, Compact Charger	2 or 4 AA - 3 hours 2 or 4 AAA - 3 hours	42.40
XD021	CHVCWB2	Basic Charger	2 or 4 AA - 12 to 14 hours 2 or 4 AAA - 6 to 9 hours	19.20

Energizer®

FLASHLIGHTS & BATTERIES

A QUICK GUIDE TO CHOOSING THE RIGHT FLASHLIGHT

How to select the light that is best for your specific needs. Just consider these basic questions:



SAFETY RATING?

It's important to know if you'll be working in a hazardous environment and exactly what type of hazards may be present. Some flashlights can be very dangerous in certain environments.

HAZARDOUS AREA ELECTRICAL GUIDELINES

CLASS	SUBSTANCE	TYPICAL ENVIRONMENTS	CLASSIFICATION VOLATILITY
1	Flammable Gases, Vapours or Liquids (Acetylene, Hydrogen, Ethylene, Propane)	<ul style="list-style-type: none"> Oil Refinery Paint Warehouse Offshore Oil Rig Spray Booth 	Division 1 (Hazard Likely) Division 2 (Hazard Not Likely)
2	Combustible Dusts (Metals [Div.1 only], Coal, Grain)	<ul style="list-style-type: none"> Coal Mine Grain Silo Munitions Factory Hay Storage Facility 	Division 1 (Hazard Likely) Division 2 (Hazard Not Likely)
3	Ignitable Fibres and Flyings (Machined Magnesium)	<ul style="list-style-type: none"> Paper Mill Woodworking Facility Textile Mill Cotton Gin 	Division 1 (Hazard Likely) Division 2 (Hazard Not Likely)

↑ MOST
↓ LEAST

DISPOSABLE OR RECHARGEABLE?

Disposable batteries, either alkaline or lithium, have excellent storage life, 7 and 10 years respectively. They generally offer longer runtimes and are typically lower in initial price than rechargeable batteries. It is also easy to keep spares on hand to replace in the field. Their operating costs are considerably higher than rechargeables (see chart) and they are seldom as bright. Lithium cells have high energy density, but are even more costly than alkaline.

TYPICAL COSTS OF A RECHARGEABLE VS. DISPOSABLE

Year	Rechargeable Flashlight Costs	D-Cell Flashlight Costs
1 st	\$97*	\$103**
2 nd	\$0	\$78
3 rd	\$0	\$78
4 th	\$0	\$78
Total	\$97	\$337

* Average suggested cost of a rechargeable flashlight

** Includes \$25 flashlight purchase and a year's worth of replacement batteries

Rechargeable flashlights using nickel cadmium, lead acid, nickel metal hydride (NiMH), or lithium ion batteries feature extraordinarily low operating expense and are well suited for frequent use. They can often support a brighter bulb or LED, and they store conveniently in custom charger holders. If you keep your rechargeable light in its charger when not in use, it's always ready and fully-charged when you need it. Their initial purchase price is higher and they self discharge at a higher rate when in storage.

LIGHT OUTPUT IS ALSO AFFECTED BY THE KIND OF BULB OR LED THAT'S IN YOUR LIGHT. HERE'S A RUNDOWN OF YOUR CHOICES:

INCANDESCENT Both xenon and halogen lamps provide high output for their size and a white, natural-appearing light. Halogen lamps "blacken" less as they age and may have longer life than xenon lamps. Both require periodic replacement and can fail on extreme impact. They are easily focused - most powerful, highest performance, top choice for long distances.

LEDs (LIGHT EMITTING DIODES) Solid-state construction. Very durable and long-lived - up to 100,000 hours. Do not require periodic replacement. Soft focus, short range. Good for close work. Typically much less power than incandescent lamps, but can give extremely long run times at low illumination levels.

POWER LEDs Reliability of a LED with the performance of an incandescent. Extremely durable, lasting 10,000 to 50,000 hours.

COMBINATION LED/INCANDESCENT LED/xenon combination lights combine the long running times and durability of LEDs with the brightness of an incandescent. Arguably the best of both worlds.

C4® TECHNOLOGY LED The latest LED technology uses a new diode chip and Streamlight's innovative use of reflectors to magnify, direct, and intensify the light beam. You get all the benefits of a LED with an intense beam that in many cases exceeds the brightness of an incandescent.

C4® LED/POWER LED COMBINATION Features the intensely bright, long reaching beam of C4® power LED, with ultra-bright LEDs for area lighting and longer run times.

HID LIGHTS (HIGH INTENSITY DISCHARGE) HID lights feature rugged high pressure plasma arc lamps that generate more lumens per watt than an LEDs or incandescent lamps. These lights can produce thousands of lumens.

LIGHT MEASUREMENT?

We recommend that a user consider two light measurement factors when choosing a portable light:

1. TOTAL LIGHT OUTPUT Lumens is a good measure of the overall visible light energy. It may be the total light coming from a bare bulb or the actual measured system output of the lighting device. It is largely a function of the light power of the bulb or LED. Lumens do not indicate how bright a target will appear. We use an integrating sphere to measure lumens.

2. PEAK BEAM INTENSITY The brightest spot of a focused beam expressed in candelas. It is a function of the bulb or LED combined with how effective the reflector is at producing a focused beam. It yields a good representation of the tightness of the focus and the apparent brightness of the light on the target at distance. We use a photometer, usually 100' away, to measure Peak Beam Intensity.

LUMENS & PEAK BEAM INTENSITY

"Lumens" of a bulb, LED or flashlight system is a measurement of the entire light output (focus is not considered).

"Peak Beam Intensity" is a measure of the brightest spot in a focused beam (A.K.A. Peak Beam Candlepower).



MAGLITE® MINI

MINI MAGLITE® AA-CELL

- High-strength aluminum alloy case
- 1/2 turn, twist focus, spot-to-flood
- Candle mode for convenient hands free light
- Spare lamp safely secured in the tail cap
- O-ring sealed for water resistance
- Super-bright Xenon Lamp™
- Includes 2 AA alkaline batteries in all package types

MINI MAGLITE® AAA-CELL

- High-strength aluminum alloy case
- Twist focus, spot-to-flood
- Spare lamp safely secured in the tail cap
- O-ring sealed for water resistance
- **XD004**: 87 lumens LED, 116 m beam distance
- Includes: Pocket clip and 2 AAA alkaline batteries

SOLITAIRE® AAA-CELL

- High-strength aluminum alloy case
- Less than 1 oz. and about 3" in length
- Spare lamp safely secured in the tail cap
- **XD003**: 37 lumens LED, 55 m beam distance
- Includes: 1 AAA alkaline battery and key lead lanyard

XA387



XA389



XA679



Model No.	Description	Lumens	Price /Each
MINI MAGLITE® AA-CELL			
XA669	Blister Pack	14	20.40
XA387	Presentation Box	14	20.80
XA678	Holster Pack	14	22.90
XA679	Combo Pack	14	22.90
MINI MAGLITE® AAA-CELL & MINI MAGLITE® LED			
XA680	Blister Pack	9	16.80
XD004	LED Black, Blister Pack	87	26.80
XA388	Presentation Box	9	17.20
SOLITAIRE® & SOLITAIRE® LED			
XA681	Black, Blister Pack	2	10.50
XD003	LED Black, Blister Pack	37	22.60
XA389	Black Presentation Box	2	10.90
XA683	Blue Presentation Box	2	10.90
REPLACEMENT BULBS			
XA701	Solitaire® Replacement Bulb	-	3.43
XA703	Replacement Bulb, fits AA and AAA	-	3.43
BATTERIES			
XB872	Replacement Batteries, AA, 24/pkg.	-	17.40
XB873	Replacement Batteries, AAA, 24/pkg.	-	19.10

MAGLITE® D-CELL

- Cam driven beam changes from flood to spot with a turn of the head
- Anodized aircraft aluminum with knurled grip enhances conductivity, increases durability, reduces oxidation and battery damage
- White Star krypton lamp provides 70% more light than a standard PR2 lamp
- Spare krypton lamp included in tail cap
- Rubber O-rings ensure resistance to water and shock
- Batteries not included

Model No.	Mfg. No.	Description	Lumens	Price /Each
XA384	S2D016	2 D-Cell Flashlight	27	41.10
XA385	S3D016	3 D-Cell Flashlight	45	42.60
XA386	S4D016	4 D-Cell Flashlight	98	44.10
REPLACEMENT BULBS				
XC955	LMXA201	Bi-Pin Xenon Bulb for 2 Cell	-	5.49
XC956	LMXA301	Bi-Pin Xenon Bulb for 3 Cell	-	5.49
XC940	LMXA401	Bi-Pin Xenon Bulb for 4 Cell	-	5.49
BATTERIES				
XB875	EN95	Replacement D-Cell Batteries, 12/Pkg.	-	21.70



MAGLITE® FLASHLIGHT ACCESSORIES



XC386



XB344



XB345



XC081



XC084



XC082



XC083



XB347



XC080



Model No.	Description	Price /Each
XB344	Belt Holster, Black Leather for 2 AA-Cell	13.70
XB345	Belt Holster, Black Nylon for 2 AA-Cell	6.16
XC386	Belt Holster, Camouflage Nylon for 2 AA-Cell	6.25
XB347	Belt Holster for D-Cell	10.60
XC080	Rubber Anti-Roll Device/Lens Holder; Red, Clear and Blue Lenses; 2 D-Cell Mounting Brackets for D-Cell	14.70
XC081	Red, Blue and Clear Lenses; Anti-Roll Device/Lens Holder; Wrist Lanyard; Pocket Clip for 2 AA-Cell	6.89
TRAFFIC WAND KITS W/REFLECTIVE TAPE		
XC082	Red, for C-Cell and D-Cell only	5.64
XC083	Yellow, for C-Cell and D-Cell only	5.72
XC084	White, for C-Cell and D-Cell only	5.72

FLASHLIGHTS & BATTERIES

MAGLITE® LED 2-CELL D FLASHLIGHTS

- Balanced Optics™ combines a highly refined reflector with a performance enhanced LED, for a brilliant adjustable beam
- Intelligent Energy Source Management balances high brightness with extended battery life
- Powerful projecting LED beam that focuses spot to flood simply by rotating the head
- Rugged, machined aluminium construction with knurled design
- Anodized inside and out for improved corrosion resistance
- Water and shock resistant
- Batteries not included
- Beam Distance: 412 m



XC240

MAGLITE® LED

Model No.	Mfg. No.	Description	Lumens	Run Time hrs.	Price /Each
XC239	ST2D016	2 D-Cell Flashlight	168	6.75	47.80
XC240	ST3D016	3 D-Cell Flashlight	168	80	49.20
BATTERIES					
XB875	EN95	Replacement D-Cell Batteries, 12/Pkg.			21.70

SEE PAGE 1507 FOR ENERGIZER® BATTERIES



MAGLITE® XL50™ LED FLASHLIGHTS

Delivers user-friendly, performance-oriented features in a sleek, tactical design and is driven by the next generation of Mag-LED™ technology.



FEATURES:

- 213 m powerful projecting LED beam
- 200 lumens
- "Spot-to-Flood" adjustable LED beam
- Push button tail-cap switch
- Compact, pocket size design
- Anodized for corrosion resistance and durability
- Rugged, machined aluminum body
- Intelligent Energy Source Management - continuously monitors the balance between high brightness and efficient power usage allowing for prolonged battery life

XC841



3 QUICK-CLICK SELECTABLE MODES:

- 1 Quick-click turns unit "ON" at high power
- 2 Quick clicks = Energy savings on at 25% power
- 3 Quick clicks = Emergency safety strobe
- Powered by three AAA alkaline batteries (included)

SPECIFICATIONS:

- Length: 4.8" (121.92 mm)
- Barrel diameter: 1" (25.4 mm)
- Head diameter: 1" (25.4 mm)
- Weight with batteries: 3.68 oz. (104 g)



XC843

BELT HOLSTERS FOR XL SERIES™ FLASHLIGHTS

- Rugged woven ballistic nylon
- Weather-resistant lock-stitched thread
- Click-adjustable rotating belt clip
- Accepts belts up to 1 5/8" wide
- Flashlight can be aimed while holstered
- Allows hands-free operation

MAGLITE® XL200™ LED FLASHLIGHTS

The XL200™ offers five basic, easy to use functions and advanced features and brightness of a next-generation LED.



The simple "Quick-Click" method let's the user select the desired function with motion-controlled variable power level and blink rate.

FEATURES:

- 138 m powerful projecting LED beam
- 172 lumens
- "Spot-to-Flood" adjustable LED beam
- Push button tail-cap switch
- Anodized for corrosion resistance and durability
- Rugged, machined aluminum body
- Sealed at both ends with high-grade rubber O-rings and lip seals

5 QUICK-CLICK SELECTABLE MODES:

- 1 Quick-click turns unit "ON" at high power
- 2 Quick-clicks = Emergency safety strobe
- 3 Quick-clicks = Nite Lite™ mode
- 4 Quick-clicks = Signal mode
- 5 Quick-clicks = SOS mode
- Powered by three AAA alkaline batteries (included)

SPECIFICATIONS:

- Length: 4.8" (121.92 mm)
- Barrel diameter: 1" (25.4 mm)
- Head diameter: 1" (25.4 mm)
- Weight with batteries: 3.68 oz. (104 g)



XC842

MAGLITE® LED

Model No.	Mfg. No.	Description	Lumens	Price /Each
XC841	XL50-S3016	3 Mode, AAA, LED	200	59.30
XC842	XL200-S3016	5 Mode, AAA, LED	172	75.60
XC843	XLXXX-A3046	Belt Holster	-	19.20
XB873	EN92	Replacement Batteries, AAA, 24/Pkg.	-	19.10/Pkg.

MINI MAGLITE® LED & PRO™

- Powerful projecting LED beam that focuses simply by rotating the head
- Balanced Optics™ combines a highly refined reflector with a performance enhanced LED yielding high output intensity
- Intelligent Energy Source Management allows the user choose the power level
- Multi-mode electronic switch: 100% power, 25% power, blink, SOS (XC238 only)
- Length: 6.6"
- Maglite® Pro™ offers latest generation LED
- Includes: 2 AA size alkaline batteries and belt holster



XC238



XC814

MAGLITE® LED

Model No.	Mfg. No.	Description	Lumens	Price /Each
XC238	SP2201H	Mini Maglite® LED Flashlight, 2 AA-Cell	97	36.90
XC814	SP2P01H	Mini Maglite® LED Pro™ Flashlight, 2 AA-Cell	272	42.00
BATTERIES				
XB872	EN91	Replacement Batteries, AA, 24/Pkg.	-	17.40/Pkg.

MAG CHARGER® LED SYSTEM FLASHLIGHTS

- High-tech metallic reflector, combined with a tempered glass lens that delivers superior optical performance
- Durable sleek black finish, hard-anodizing inside and out for improved durability
- O-ring sealed throughout for resistance to weather and harsh environmental conditions
- Precision machined high-strength aluminum alloy case
- Individually serial numbered for identification
- NiMH rechargeable battery offers 434 m powerful projecting LED adjustable beam
- 643 lumens lasting 17 hours at low setting or 4 hours at high setting
- Quick access to your preferred functions: Full power, Power save (25%) Strobe (5/sec), SOS (Int'l Morse code), Momentary On/Off
- Length: 12 1/2"
- Weight: 2 lbs.

XD007 System (V4) Includes:
 Mag Charger® flashlight,
 charging cradle,
 NiMH rechargeable battery pack,
 two mounting brackets,
 120 V converter, mobile
 power adapter (12 V)



MAGLITE® LED

Use the **XD007** rechargeable system just as it is (see Function Set #1 Standard) or personalize it to meet your own needs by choosing one of the other function sets in the chart shown below.

	Function Set 1 (standard)	Function Set 2	Function Set 3	Function Set 4
1 Click	Full Power	Full Power	Momentary	Momentary
2 Clicks	Power Save	Power Save	Full Power	Full Power
3 Clicks	Strobe	SOS Signal	Power Save	Strobe

Model No.	Mfg. No.	Description	Lumens	Price /Each
XD007	RL1019	Rechargeable LED System	643	231.00
XC849	ARXX235	Replacement NiMH Battery Pack	-	55.70

MAG-TAC™ LED TACTICAL FLASHLIGHTS

- Three functions with tailcap switch "Quick Click" access
- Features three modes: Momentary, Full Power, Power Save
- Two power levels (Full Power for extreme brightness and Power Save for prolonged battery life)
- Momentary mode (in which the light stays on only while the switch button is being pressed)
- Detachable pocket clip
- 310 lumens
- 182-m projecting beam
- Plain bezel head
- Powered by two CR123 lithium batteries included
- Length: 5.195" (131.95 mm)

Barrel diameter:
1.050" (26.67 mm)

Head diameter:
1.050" (26.67 mm)

Weight with batteries:
4.8 oz. (136 g)



XD005

XD014

MAGLITE® LED

Model No.	Mfg. No.	Description	Lumens	Price /Each
XD005	SG2LRE6	Black, Mag-Tac™ LED	310	107.00
XD014	SG2LRH6	Coyote Tan, Mag-Tac™ LED	310	107.00
XD008	AG2L016	Nylon Belt Holster	-	19.00

MAG-TAC™ LED CROWN BEZEL TACTICAL FLASHLIGHTS

- Three functions with tailcap switch "Quick Click" access
- Features three modes: Momentary, full power, strobe
- Momentary mode, light stays on only while the switch button is being pressed
- Full power mode, 320-lumen beam that can light up an object two football fields away
- Strobe mode, high-energy 12 Hz
- Detachable pocket clip
- 193-m projecting beam
- Crowned bezel head
- Powered by two CR123 lithium batteries included
- Length: 5.275" (131.95 mm)

Barrel diameter:
1.050" (26.67 mm)

Head diameter:
1.050" (26.67 mm)

Weight with batteries:
4.8 oz. (136 g)



XD006

XD015

MAGLITE® LED

Model No.	Mfg. No.	Description	Lumens	Price /Each
XD006	SG2LRA6	Black, Mag-Tac™ LED, Crown Bezel	320	127.00
XD015	SG2LRD6	Coyote Tan, Mag-Tac™ LED, Crown Bezel	320	127.00
XD008	AG2LR016	Nylon Belt Holster	-	19.00

FLASHLIGHTS & BATTERIES

PROTAC® PROFESSIONAL TACTICAL LIGHTS

- 6000 Series machined aircraft aluminum with anodized finish
- Super bright C4® LED is impervious to shock and has a 50 000 hour lifetime
- LED solid state power regulation provides maximum output throughout battery life
- IPX rated design; waterproof to 1 m for 30 minutes
- Ten-Tap™ programmable switch allows selection of one of three programs: High/Strobe/Low, High only or Low/High
- Includes batteries and holster



Model No.	Mfg. No.	Description	Lumens	Run Time hrs.	Battery	Price /Each
XC770	88030	ProTac® 1 L	180	2	One 3 V Lithium	85.30
XC771	88031	ProTac® 2 L	260	3	Two 3 V Lithium	96.60
XC772	88032	ProTac® 1 AA	70	2	1 AA Alkaline	77.30
XC773	88033	ProTac® 2 AA	155	2	2 AA Alkaline	79.60

PROTAC® HL & HL3 TACTICAL FLASHLIGHTS

- Hand-held, lithium battery-powered programmable flashlight constructed of anodized machined aircraft aluminum
- IPX7; waterproof to 1 meter for 30 minutes
- Impact resistant to 1 meter
- Multi-function, push-button tail switch for one-handed operation
- Choice of three operating modes: 1) high/strobe/low (factory default), 2) high only, 3) low/high
- Lamp Type: C4 LED
- Model **XC954**: Includes two 3 V CR123A lithium batteries and nylon holster
- Model **XD783**: Includes three 3 V CR123A lithium batteries, removable pocket clip and nylon holster



Model No.	Mfg. No.	Description	Lumens		Run Time hrs.		Price /Each
			High	Low	High	Low	
XC954	88040	ProTac® HL	600	33	1.25	18	153.00
XD783	88047	ProTac® HL3	1100	35	2	43	176.00

STREAMLIGHT JR.® LED FLASHLIGHTS

- Super bright C4® LED is impervious to shock and provides up to 85 lumens
- Push-button tail switch - steady on and momentary on/off operation
- Impact-resistant/water-resistant
- **XC247** includes holster
- **XC248** includes extension cable that allows for 14" of reach, flexible cable protected by a durable PVC coating, packaged with magnetic clip holder for mounting and positioning
- Includes 2 AA size alkaline batteries (also accepts 2 AA lithium batteries not included)



Model No.	Mfg. No.	Description	Lumens	Run Time hrs.	Price /Each
XC247	71500	Streamlight Jr® LED w/Alkaline Batteries, Black	85	4	62.60
XC248	71600	Streamlight Jr. Reach® LED Flashlight	85	3.25	78.10

BATTERIES

XB872	EN91	Replacement Batteries, AA Cell, 24/pkg.	-	-	17.40/Pkg.
-------	------	---	---	---	------------

STYLUS® PENLIGHTS

- High intensity LED lasts 100 000 hours
- Up to 24 hours of continuous run time
- **XB942** has a flexible cable making it possible to see anywhere
- Includes 3 AAAA alkaline batteries
- Black casing with pocket clip



Model No.	Mfg. No.	Description	Lumens	Price /Each
XB943	65118	Stylus® Penlight, 3.5 oz.	11	27.10
XB942	65618	Stylus Reach® Penlight - 7" Cable, 3.5 oz.	11	36.90

STYLUS PRO® & MICROSTREAM® PENLIGHTS

- Compact, high-powered LED penlights provide a super bright beam
- Constructed of corrosion proof, machined aircraft-grade aluminum alloy with Type II MIL-Spec anodized plating
- 30 000 hour lifetime 0.5 watt LED never needs to be replaced
- Water resistant per code IPX4; in accordance with specification EN 60529:1992
- Tail switch features momentary blink and constant "on" modes
- Matte black finish



STYLUS PRO®

- Produces up to 65 lumens
- Run time: Up to 6.5 regulated hours
- Includes: 2 AAA alkaline batteries, nylon holster and pocket clip

Model No. **XC394**
Mfg. No. 66118
Price/Each \$39.00

MICROSTREAM®

- Produces up to 35 lumens
- Run time: Up to 2.25 hours
- Includes: 1 AAA alkaline battery, pocket clip and lanyard

Model No. **XC395**
Mfg. No. 66318
Price/Each \$33.40

TWIN-TASK® LED FLASHLIGHTS

- Super bright C4® LED is impervious to shock and has a 50 000 hour lifetime
- Unbreakable polycarbonate lens
- IPX4 rated for water-resistant operation, all openings are O-ring sealed, 1 meter impact resistance tested and wrist lanyard included

TWIN-TASK® 3 AAA LASER LED

- Features: 2 hr 45 min on one LED, 5 hr 15 min on five LEDs
- Battery: 3 AAA size alkaline batteries, Output: One LED - 100 lumens, five LEDs - 68 lumens
- Pre-focused visible red laser cartridge, laser output: Useable range of over 100 yards when using laser pointer only; over 100' when in laser/C4® LED combo position

TWIN-TASK® 3 C LED

- Features: Runtime 26 hrs on one LED, 72 hrs on three LEDs and 48 hrs on six LEDs
- Battery: 3 C size alkaline batteries, Output: One LED - 180 lumens, three LEDs - 50 lumens, six LEDs - 80 lumens



Model No.	Mfg. No.	Description	Lumens	Price /Each
XC762	51043	Twin-Task® 3 AAA LED	100	75.40
XC763	51039	Twin-Task® 3 C LED	180	75.40

STINGER®, STINGER® LEDS, POLYSTINGER® & POLYSTINGER® LEDS

- Compact, rechargeable flashlights that are not only durable, but super bright
- Charge time: 10 hours to fully charge; 2.5 hour fast charger model available
- Push button switches on the head for momentary or constant "on-off" switching
- Includes a nickel cadmium battery that is rechargeable up to 1000 times
- Optional accessories: safety wands, 5-unit bank charger, ring holder, holster, PiggyBack® charger, coloured flip lens covers

STINGER®/POLYSTINGER®

- Feature a xenon bulb with an adjustable focus beam that provides 1.25 hour of continuous run time
- Includes a spare bulb in the tail cap
- Stinger® is constructed of aircraft machined aluminum with polycarbonate lens
- PolyStinger® is constructed of nylon polymer with non-slip rubber grip

STINGER® LED/POLYSTINGER® LED

- 4 modes of lighting: High, Medium, Low or Strobe
- Features a C4® LED that is impervious to shock and has a 50000 hour lifetime - never needs to be replaced
- Run times: **High beam** - Up to 2 continuous hours;
Medium - Up to 3.75 continuous hours;
Low - 7.25 continuous hours;
Strobe - Up to 5.5 continuous hours
- Stinger® LED constructed of aircraft machined aluminum with polycarbonate lens
- PolyStinger® LED is constructed of super-tough non-conductive nylon polymer with a non-slip rubber grip



Model No.	Mfg. No.	Description	Lumens	Approvals	Price /Each
XC396	76014	PolyStinger®	90	UL Class I, II, Div. 2	201.00
XC397	75713	Stinger® LED	350	-	232.00
XC480	76163	PolyStinger® LED	385	-	227.00
XC398	75914	Bulb, Stinger®/PolyStinger®	-	-	13.70
XC399	75175	Battery for all 4 models	-	-	31.50

4AA PROPOLYMAX® HIGH-OUTPUT FLASHLIGHTS

- C4® LED technology for extreme brightness
- Impact and chemical resistant engineering polymer resin
- Unbreakable polycarbonate lens with scratch resistant coating
- Smooth parabolic reflector produces a tight beam with optimum peripheral illumination
- TEN-TAP® programmable switch allows user selection of one of three different programs
- Lamp Type: LED
- Lumens (High): 300
- Lumens (Low): 50
- Run Time Hrs. (High): 2.75
- Run Time Hrs. (Low): 24
- Beam Distance: 261 m
- 4 AA batteries included

Model No. XD492
Mfg. No. 68820
Price/Each \$85.30



PROPOLYMER® FLASHLIGHTS

- Waterproof, non-conductive polymer casings
- Easy to use push button momentary or constant "on-off" switching
- XC051 and XC054 feature super bright, 100000 hour lifetime LEDs
- XC056 and XC477 contain a super high flux LED with a 10000 hour lifetime
- XC054, XC056 and XC477 include batteries
- XC051 has a spring loaded clip
- XC051 and XC054 are CUL Listed Class I, II, Div. 2, Class III and MSHA approved
- XC477 and XD467 are CUL Listed for Class I, II, Div. 1, Class III and MSHA approved
- XC053 and XC056 are CUL Listed for Class I, II, Div. 2, Class III
- XD304 and XD487: ANSI/UL 913 CAN/CSA C22.2 No. 157-92 intrinsically safe equipment for use in hazardous locations
- XD436: Intrinsic Safety for Haz. Loc. Class I, II, Div. 1, Groups A,B,C,D,E,F,G; Class III, T4A

STINGER LED HL® RECHARGEABLE FLASHLIGHTS

- C4® LED technology for extreme brightness
- Deep-dish parabolic reflector produces a concentrated beam with optimum peripheral illumination
- 1 metre impact resistance tested
- 120 V AC /12 V DC
- IPX4 water-resistant
- Lumens (High): 640
- Lumens (Low): 170
- Run Time Hrs. (High): 1.25
- Run Time Hrs. (Low): 4
- Beam Distance: 297 m
- Comes with 2 holders
- 1 rechargeable battery included



Model No.	Mfg. No.	Description	Price /Each
XD617	75430	Stinger LED HL® Rechargeable Flashlights	267.00
XC399	75175	Replacement Rechargeable Batteries	31.50



Model No.	Mfg. No.	Description	Lumens	Price /Each
XC051	33202	3 C LED, 336 Hours of Continuous Run Time	85	70.30
XC054*	68202	4 AA LED, 155 Hours of Continuous Run Time	85	49.90
XC056*	68244	4 AA Lux LED, Div. 2, 4 Hours with 2 Additional Hours of Declining Usable Light	34	68.20
XD436	62202	3 "W" Size Alkaline, LED, 120 Hours of Continuous Run Time	30	32.80
XD467*	67101	2 AA LED, HAZ-LO®, 24 Hours of Continuous Run Time	65	37.80
XD487	68720	3 AA LED, HAZ-LO®, 6.5 Hours of Continuous Run Time	120	82.80
XD304	33820	3 C LED, HAZ-LO®, 18 Hours of Continuous Run Time	150	88.70

* Batteries included

FLASHLIGHTS & BATTERIES

MITYLITE™ 1900

- Made of unbreakable space age hi-impact polycarbonate resin
- 4.09" in length
- Xenon lamp module provides 7.0 lumens of power
- Equipped with a shirt clip, making it easy to fit into pockets, purses, tool kits, camera bags or glove compartments
- Submersible with a twist on shroud
- Includes 2 AAA alkaline batteries



APPROVALS

CSA: Class I, Div. 2, Groups ABCD, T3C
Class II, Div. 2, Group G
IEC EX: Ex ib e IIC T4 IP67 IEC Ex TSA 06.0021X



Model No.	Mfg. No.	Description	Lumens	Price /Each
XA027	1900-015-245	Mitylite™ 1900	7	23.60
XA018	1900-350-000	Replacement Bulb	-	8.73

MITYLITE™ 2340

- 6 1/4" in length and equipped with a handy tail button switch
- Made of an unbreakable chemical resistant resin with a polycarbonate lens and thermoplastic rubber shroud
- Includes a pre-focused xenon lamp module, shirt clip and 2 AA-cell Energizer® alkaline batteries
- Non-submersible



APPROVALS

CSA: Class I, Div. 2, Groups ABCD, T3C
Class II, Div. 2, Group G
FM: Class I, Div. 2, Groups ABCD, T3A
MSHA: 10C-637-0
IEC EX: Ex ib e IIC T4 IP67 IEC EX TSA 06.0021x



Model No.	Mfg. No.	Description	Lumens	Price /Each
XB349	2340-010-110	Black	10	34.90
XB350	2340-010-245	Yellow	10	34.90
XB351	2300-350-000	Replacement Bulb	-	11.80

BATTERIES

XB872	EN91	Replacement Batteries, AA-Cell, 24/Pkg.	-	17.40/Pkg.
-------	------	---	---	------------

VB3™ 2220 LED FLASHLIGHTS

- Dual super bright white LEDs
- Lumens: 9
- Run Time Hrs.: 34
- Beam Distance: 12 m
- Light turns on when the head is flipped up
- Pivots to a full 180°
- Built-in clip attaches to surfaces up to 1/2" thick
- 2 CR2032 3 V Lithium coin cells included
- IPX4 Water resistant

XC805



Model No.	Mfg. No.	Colour	Price /Each
XC805	2220-010-110	Black	34.40
XE300	2220-010-245	Yellow	34.40

1930 L1™ LED LIGHTS

- Water resistant light provides a concentrated close quarter beam
- Provides up to 50000 hours of usage
- Four replaceable LR 44 alkaline coin cells (included)
- Offers up to 130 hours of battery life
- Lumens: 12
- Equipped with a neck lanyard and a handy push button on/off switch
- Colour: Black



APPROVALS

UL: Class I, Div. 1, Groups ABCD
IECEX: Ex ia IIC T4 IP65

Model No. XB352
Mfg. No. 1930-010-110
Price/Each \$28.70



3315 COMPACT LED FLASHLIGHTS

- Compact, rugged and lightweight
- Constructed of high impact ABS
- 113 lumens, 9 h 45 m runtime
- Powered by three AA alkaline batteries (included)
- Water resistant IPX4
- Class I II III, Div. 1, GP. ABCDEFG T4 Exia



Model No.	Mfg. No.	Description	Lumens	Price /Each
XD018	033150-0150-110	Black, 3315 Compact LED Flashlight	113	54.20
XD019	033150-0150-245	Yellow, 3315 Compact LED Flashlight	113	54.20
XB872	EN91	Replacement Batteries, AA-Cell, 24/Pkg	-	17.40/Pkg.

RIGHT ANGLE 3715 LED FLASHLIGHTS

- Compact, rugged and lightweight
- Featuring downcast LEDs for illuminating your path
- 4-mode unit:
 - High** - 174 lumens, 4 h 45 m runtime
 - Low** - 95 lumens, 8 h 30 m runtime
 - Signaling** mode - 142 lumens, 31-hour runtime
 - Downcast** - 32 lumens, 10-hour runtime
- Built-in battery life indicator
- Powered by four AA alkaline batteries (not included)
- Water-resistant IPX4
- Class I, Div. 1 Groups ABCD
Operating Temp. Class T4



Model No.	Mfg. No.	Description	Lumens	Price /Each
XD016	3715-000-110	Black, Right Angle 3715 LED Flashlight	174	176.00
XD017	3715-000-245	Yellow, Right Angle 3715 LED Flashlight	174	176.00
XB872	EN91	Replacement Batteries, AA-Cell, 24/Pkg.	-	17.40/Pkg.

KNUCKLEHEAD® SPOT LED FLASHLIGHTS

- Shockproof C4® premium LED technology
- Deep dish parabolic reflector produces a focused beam for longer distances: 210 m on high beam
- Durable spring-loaded clip for easy attachment to turnout gear and uneven surfaces
- Features a 210° articulating head that rotates a full 360°
- Four modes:

High: 11,000-candela peak beam intensity, 180 lumens, 3.5-hour runtime

Low: 3300-candela peak beam intensity, 55 lumens, 16-hour runtime

Moonlight: 20-day runtime

Flash: 8-hour runtime

- Dual power source: accepts rechargeable NiCad battery pack or four AA alkaline batteries
- Rubber dome push-button actuator is easy to operate even when wearing heavy gloves
- Removable magnet with 135-lb. pull strength features a replaceable rubber boot
- Optimized electronics provide regulated intensity
- High-impact, super-tough nylon polymer construction for exceptional durability
- 2-m impact-resistance tested
- IPX4-rated for water-resistance



Model No.	Mfg No.	Description	Lumens	Price /Each
XD010	90757	Knucklehead® Spot 120 V AC/12 V DC, Orange	180	297.00
XD011	90761	Knucklehead® Spot 120 V Fast Charge, Orange	180	337.00
XD012	90770	Knucklehead® Spot 12 V Fast Charge, Orange	180	337.00
XA988	22311	120 V AC Charge Cord	-	27.90
XD013	90011	AC Fast Charger (Includes Holder)	-	92.90
XC404	90338	NiCd Battery Pack, (Rechargeable), Div. 2	-	71.10
XC405	90542	Alkaline Battery Pack (Batteries Not Included)	-	7.58
XB872	EN91	Replacement Alkaline Batteries, AA, 24/Pkg.	-	17.40/Pkg.

KNUCKLEHEAD® FLOOD LED FLASHLIGHTS

- High-impact super-tough nylon offering exceptional durability
- Super-bright C4® LED is impervious to shock and has a 50 000 hour lifetime
- IPX4-rated for water resistant operations
- All openings O-ring sealed
- Full 360° rotation head with 210° of articulation
- Removable magnet with 135-lb. pull strength and integrated hook
- Lens is an unbreakable polycarbonate with silicone anti-scratch coating and is assembled in a heavy-duty bezel
- **XD862:** AC/DC - Class I, Div. 1 approved for hazardous locations
- **XD863:** Class I, Div. 1 approved for hazardous locations
- **XD863** includes 4 AA alkaline batteries
- Charger meets requirements of NFPA 1901-14.1.11.2 (2003) mounted in any position



Model No.	Mfg. No.	Battery	Lumens	Price /Each
XC766	90627	Industrial Rechargeable Nickel-Cadmium 4.8 V Can be Charged Up to 1000 Times	200	297.00
XC767	90642	4 AA Alkaline Non-Rechargeable Battery Pack	200	166.00
XD862	91627	HAZ-LO® Rechargeable Worklight	163	315.00
XD863	91642	HAZ-LO® Worklight	163	172.00
ACCESSORIES				
XC823	90400	Bank of 5 Chargers 120 V AC for XC766, XC767 & XD862	-	543.00

SURVIVOR®

- Brightest right-angle LED flashlight available
- Features a C4® LED with a 405 m. range and optimal peripheral illumination
- LED produces up to 175 lumens and has a 50 000 hour lifetime
- Raised push button switch features: High, Low, Flash and moonlight
- Run time (rechargeable):
High 3.5 hours; **Low** 13 hours; **Flash** 5 hours; **Moonlight** 20 days
- Run time (alkaline): **High** 4 hours; **Low** 15 hours; **Flash** 8 hours; **Moonlight** 20 days
- Constructed of high-impact, super-tough nylon for durability and O-ring sealed for water-resistance
- Unbreakable polycarbonate lens with silicone anti-scratch coating
- Rechargeable models also include alkaline battery pack (alkaline batteries not included)
- Operates on 4 AA alkaline or rechargeable NiCd battery pack
- Serialized for easy identification
- UL Approved for Class I, Div. 1, Groups C, D; Class I, Div. 2, Groups A, B, C, D; Class II Div. 11, Groups F, G, Class III, T4, MSHA alkaline only



Model No.	Mfg. No.	Description	Lumens		Colour	Price /Each
			High	Low		
XC400	90513	Survivor® Rechargeable	175	60	Yellow	250.00
XC401	90503	Survivor® Rechargeable	175	60	Orange	250.00
XC402	90540	Survivor® Alkaline	175	60	Orange	116.00
XC403	90541	Survivor® Alkaline	175	60	Yellow	116.00
XC404	90338	NiCad Battery Pack (Rechargeable), Div 2	-	-	-	71.10
XC405	90542	Alkaline Battery Pack (Batteries Not Included)	-	-	-	7.58

POLYTAC 90® COMPACT LIGHTS

- High-impact, super tough nylon offering exceptional durability
- Super-bright C4® LED is impervious to shock and has a 50 000 hour lifetime
- IPX7 rated design; waterproof to 1 m for 30 minutes
- Lens is glass and gasket sealed
- 90° head, integrated carabineer style D-ring for a variety of attachment methods fully rotatable/reversible/removable clip to allow for a variety of mounting positions
- Head-mounted, push-button switch provides one-handed momentary or constant on operation
- Gear keeper tool lanyard tether features spectra nylon line with 36" extension 6 oz. retraction force
- Includes two 3 V CR123A lithium batteries



Model No.	Mfg. No.	Description	Lumens	Colour	Price /Each
XC775	88831	PolyTac 90® Compact Light	170	Yellow	99.50
XC774	88832	PolyTac 90® Light w/ Gear Keeper	170	Orange	123.00
XC776	88833	Gear Keeper Tool Lanyard	-	Black	26.60
XC006	EL123AFBP	Replacement 3 V Lithium Batteries	-	-	4.53

FLASHLIGHTS & BATTERIES

E-FLOOD® LITEBOX® RECHARGEABLE LANTERNS

- Produces up to 4000 candelas and has 615 lumens on high power
- IPX4-rated design for weather resistant operation
- Fits existing Streamlight LiteBox® racks
- Six LEDs produce a smooth flood pattern
- Battery is a zero maintenance 6 V, 12 Ah sealed lead acid and is rechargeable up to 500 times
- Red and green LEDs provide charge status
- Charge rack meets requirements of NFPA standard 1901-14.1.11.2 (2003) mounted in any position



Model No.	Mfg. No.	Colour	Lumens	Price /Each
XC757	45801	Orange	615	374.00
XC758	45821	Yellow	615	374.00
XD384	45817	Beige	615	388.00

WAYPOINT® PISTOL GRIP SPOTLIGHTS

- C4® LED technology, with a 50 000 hour lifetime
- Three modes of lighting: High, low and emergency signal
- IPX4 rated design for water resistant operation
- Integrated stand for hands-free scene lighting
- Unbreakable polycarbonate lens
- **XC764** and **XC765**: Powered by 4 "C" batteries (not included) or 12 V DC power cord (included)
- Run time (**XC764** and **XC765**): High 10 hrs.; 12 V DC power cord: Unlimited
- Run time (**XD331** and **XD332**): High 3 hrs.



Model No.	Mfg. No.	Lumens	Description	Colour	Price /Each
XC764	44900	550	Spotlight, Alkaline Batteries	Yellow	116.00
XC765	44902	550	Spotlight, Alkaline Batteries	Black	116.00
XB874	EN93	-	Replacement batteries, C-cell, 12/pkg.	-	19.60/pkg
XD331	44910	1000	Spotlight, Rechargeable	Yellow	232.00
XD332	44911	1000	Spotlight, Rechargeable	Black	232.00

FIRE VULCAN® LED

- Lightweight, waterproof lantern features super bright C4® LED technology and two blue taillight LEDs that provide illumination both in front of and behind the lantern
- C4® LED produces up to 80 000 Candela (Peak Beam Intensity), is impervious to shock and has a 50 000 hour lifetime
- The 2 ultra-bright blue taillight LEDs can be seen through thick smoke
- Run times: Steady LED and taillights - Up to 3 hours to the 10% output level (High) and up to 7 hours (Low)
- High power 145 lumens; low power 70 lumens
- 8 total programmable functions - 4 functions when toggle switch in "left" position and 4 functions when toggle switch is in "right" position
- IPX7 rated design - waterproof to 1 meter for 30 minutes; lantern floats
- Raised handle and toggle "on-off" switch ensure ease of use with a gloved hand
- Super lightweight lithium ion battery recharges in 5 hours
- Includes shoulder strap, AC/DC charge cords and charging rack
- Class I, Div. 2, Groups A, B, C, D; Class II, Div. 2, Groups F, G; Class III T-Code: T4
- Rack meets requirements of NFPA standard 1901-14.1.11.2 (2003) mounted in any position



Model No. **XC406** Mfg No. 44450
Price/Each **\$346.00**

E-SPOT® LITEBOX® RECHARGEABLE LANTERNS

- Uses three LEDs and deep-dish parabolic reflectors to produce a large spot pattern
- Run time: High - up to 7 continuous hours; Low - up to 15 continuous hours
- Produces up to 55 000 candelas and has 540 lumens on high power
- IPX4 rated design for weather resistant operation
- Fits existing Streamlight LiteBox® racks
- Includes 6 V, 12 Ah sealed lead acid rechargeable battery; rechargeable up to 500 times
- Rack meets requirements of NFPA standard 1901-14.1.11.2 (2003) mounted in any position



Model No.	Mfg. No.	Lumens	Colour	Price /Each
XC759	45851	540	Orange	337.00
XC760	45871	540	Yellow	337.00

SABRELITE® 2000

- Watertight to 500'
- Made out of unbreakable ABS material with a hi-impact polycarbonate lens
- Has an exclusive state-of-the-art xenon lamp module that produces a tightly focused collimated white light beam with 33 lumens of power
- Safe to be used in gaseous or electrical hazardous environments
- Requires 3 C-cell (batteries not included)
- Length: 7.79"
- Includes: Belt spring clip, stainless steel split ring and black lanyard



APPROVALS

FM: Class I, II, Div. 2, Groups ABCD/G, T3C
MSHA: 10C-629-2
CSA: Class I, Div. 2, Groups ABCD, T3C
Class II, Div. 2, Group G
IEC EX: Ex ib e IIC T4 IP67
UL: Class I, Div. 1, Groups CD,
Class I, Zone I, Groups IIA, IIB, T3C



Model No.	Mfg. No.	Description	Lumens	Price /Each
XA129	2000-010-245	Yellow	33	58.50
XA130	2000-010-110	Black	33	58.50
XA012	2000-351-000	Replacement Bulb	-	21.40

STEALTHLITE™ 2400

- This 4 AA-cell flashlight is water resistant with an unbreakable corrosion proof ABS body and hi-impact polycarbonate lens
- Xenon lamp module gives an unsurpassed white collimated beam
- Has a one handed on/off locking switch plus a heavy-duty lanyard
- Safe to be used in gaseous or electrical hazardous environments
- Colour: Orange



APPROVALS

FM: Class I, Div. 2, Groups ABCD, T3A
MSHA: 10C-633-0
CSA: Class I, Div. 2, Groups ABCD, T3C
Class II, Div. 2, Group G
UL: Class I, Div. 1, Group D, Zone 1, IIA, T3
Ex (CE): II 3 GD EEx n IIC T5 sni 135°C



Model No.	Mfg. No.	Description	Lumens	Price /Each
XA026	2400-010-150	StealthLite™ 2400	45	59.50
XA019	2400-351-000	Replacement Bulb	-	20.50

BATTERIES

XB872	EN91	Replacement Batteries, AA-Cell, 24/Pkg.	-	17.40/Pkg.
-------	------	---	---	------------

FLASHLIGHTS & BATTERIES

FLASHLIGHTS

- Super bright LED bulb
- Polypropylene body resists grease and chemicals
- Shatterproof lens
- Ribbed non-slip barrel
- Hi-Viz yellow colour for easy visibility
- Batteries not included



Model No.	Mfg. No.	Description	Lumens	Price /Each
XC977	LA765A	Flashlight, 2 AA-Cells	28	3.75
XB872	EN91	Replacement Batteries AA-Cell, 24/Pkg.	-	17.40/Pkg.
XC978	LA765C	Flashlight, 2 D-Cells	35	5.40
XB875	EN95	Replacement D-Cell Batteries, 12/Pkg.	-	21.70/Pkg.

ENERGIZER HIGH INTENSITY LED FLASHLIGHTS

- Suitable for outdoor use
- FL1 Weatherproof standard
- Meets IEC 60529 IPX4 standards
- Survives 3-meter drop test
- Slip-resistant knurled grip
- Easy to operate push button switch
- Nylon lanyard
- Run time: 2 hours and 25 minutes
- Includes two 2AA batteries



Energizer

Model No.	Mfg. No.	Description	Lumens	Price /Each
XC959	EMHIL21E	High Intensity LED Flashlight	150	39.70
XB872	EN91	Replacement Batteries AA-Cell, 24/Pkg.	-	17.40/Pkg.

LED INDUSTRIAL FLASHLIGHTS

- Super tough body resists grease and chemicals
- Bright yellow colour for high visibility
- Easy-to-operate switch
- Shatterproof lens
- Ribbed non-slip, non roll barrel
- Batteries not included



Model No.	Mfg. No.	Description	Lumens	Price /Each
XD078	1151L	LED Industrial Flashlight	30	6.08
XB872	EN91	Replacement Batteries AA-Cell, 24/Pkg.	-	17.40/Pkg.

EVEREADY™ LED LANTERNS

- Bright white LED
- Lasts 5X longer than incandescent
- Shatterproof lens
- Floating lantern
- Run time hrs.: 65
- Colour: Yellow
- 6 V battery included

EVEREADY



Model No.	Mfg. No.	Description	Lumens	Price /Each
XD193	5109LS	LED Lantern	25	11.20

LED FLASHLIGHTS

- 45 LED bulb
- High strength aluminum casing
- Shatterproof lens
- 3 lighting settings: Low 9 LED, Medium 24 LED and High 45 LED
- Lumens (High): 157
- Lumens (Low): 31
- Run Time Hrs. (High): 2
- Run Time Hrs. (Low): 3
- Batteries included

Model No. XE889
Price/Each \$19.95



OFFICE PRODUCTS

INSTRUMENTS, SCALES & ELECTRICAL

SHIPPING & PACKAGING

TOOLS & EQUIPMENT

WELDING & METALWORKING

SAFETY EQUIPMENT & SUPPLIES

JANITORIAL & MAINTENANCE

MATERIAL HANDLING & STORAGE

MINI LED FLASHLIGHTS

- Nine ultra bright LED lights
- High-strength aluminum casing
- On/Off switch
- Lightweight design
- Rugged impact resistant housing
- Includes wrist strap and three AAA alkaline batteries



Model No.	Mfg. No.	Description	Lumens	Price /Each
XD079	LA671	Mini LED Flashlight	25	10.50

LED RUBBER FLASHLIGHTS

- Two bright Nichia LED's
- 22 lumens, 16-hour runtime
- Focusing lens projects a precise spot
- Push button switch
- Built-in stand
- Non-roll foot
- Includes two AA Energizer® batteries



Energizer

Model No.	Mfg. No.	Description	Lumens	Price /Each
XC958	ENRUB21E	Black, 3315 Compact LED Flashlight	22	16.60
XB872	EN91	Replacement Batteries AA-Cell, 24/Pkg.	-	17.40/Pkg.

CONTRACTOR® SERIES INTRINSICALLY SAFE LIGHTS

- Designed to meet the needs of hazardous work environments by combining the major performance advantages of LED without sacrificing brightness
- Chemical-resistant, anti-static polyethylene construction
- Carabiner belt hook on tall cap
- Survives 7' drop test
- CUL 913 Certified Intrinsically Safe for Class I, Groups A, B, C and D; Class II, Groups E, F and G; Class III
- CAN/CSA C22.2 No. 157-92
- IEC 60529 waterproof and dustproof
- AA batteries not included



Model No.	Mfg. No.	Description	Avg life	Lumens	Price /Each
XC324	MS2AALED	Three White Nichia CS	20 hrs	40	22.90
XB872	EN91	Replacement Batteries AA-Cell, 24/Pkg.	-	-	17.40/Pkg.

WEATHERPROOF FLOATING LANTERNS

- Weatherproof
- 6 V spring battery or 4 D batteries not included



Energizer

Model No.	Mfg. No.	Description	Lumens	Price /Each
XA405	1700	Weatherproof Floating Lantern	22	13.60
XA430	529	Replacement Batteries 6 V Spring, 1/Pkg.	-	14.80/Pkg.
XB875	EN95	Replacement D-Cell Batteries, 12/Pkg.	-	21.70/Pkg.

LED FLASHLIGHTS

- 28 LED bulb
- High strength aluminum casing
- Shatterproof lens
- Lumens (High): 98
- Run Time Hrs. (High): 2
- Run Time Hrs. (Low): 3
- Batteries included

Model No. XE888
Price/Each \$14.75





LED FLASHLIGHTS

- Cutting edge Recoil™ LED Technology™, up to 33 times brighter than regular LED lights
- Focuses the light by firing backwards; 100% of the light is captured and reflected forward



SABRELITE™ 2010 LED

- Rugged, lightweight Xenon® body
- White collimated beam as bright as an incandescent light
- 109 lumens
- Submersible to 500'
- Powered by three C-cell alkaline batteries, not included



XC062

APPROVALS

CSA: Class I, Div. 1, Group D
Class I, Div. 2, Groups ABCD
Class II, Div. 2, Groups FG, T3C

US FM C: Class I, Div. 1, Group D
Class I, Div. 2, Groups ABCD
Class II, III, Div. 1, Groups FG

STEALTHLITE™ 2410 LED

- ABS body with polycarbonate lens
- One-handed safety switch operation
- 126 lumens
- Submersible to 500'
- Powered by four AA-cell alkaline batteries, included



XC066

APPROVALS

FM: Class I, Div. 2, Groups ABCD, T4A
Class II, Div. 2, Groups FG

Model No.	Mfg. No.	Description	Lumens	Price /Each
SABRELITE™ 2010 LED				
XC061	2010-016-110	Black	190	96.40
XC062	2010-016-245	Yellow	190	96.40
XB874	EN93	Replacement C-Cell Batteries, 12/pkg.	-	19.60/Pkg.
STEALTHLITE™ 2410 LED				
XC066	2410-016-110	Black	126	95.30
XC067	2410-016-245	Yellow	126	95.30
XB872	EN91	Replacement AA-Cell Batteries, 24/pkg.	-	17.40/Pkg.

PORTABLE RECHARGEABLE LED SCENE LIGHTS

- Six C4™ LEDs and wide pattern parabolic reflectors produce a smooth flood pattern
- Indefinite run time with 12 V power cord
- 3 levels of lighting
- Wattage: 36 W
- Stabilization legs provide balance on uneven surfaces
- 90° swivel neck allows you to aim the beam where you need it for task lighting
- Packs to a compact size for easy storage
- Pole extends to 72"
- Weatherproof construction



Model No.	Mfg. No.	Description	Lumens	Price /Each
XE753	45670	Portable Rechargeable LED Scene Light	3600	1306.00

RECHARGEABLE SPOTLIGHTS

- 19 super bright LED lights
- Lightweight design
- Rugged impact resistant housing
- 2.5 million candle power
- 10-hour run time with full charge
- Comes with 110 V adaptor and 12 V car plug
- Certified for sale in Canada by an accredited certification body



Model No. XC668

Price/Each \$39.75

2 000 000 CANDLEPOWER SPOTLIGHTS

- Quartz halogen beam technology for maximized beam power and distance
- Durable black ABS housing and non-skid rubber bezel
- 12-volt, 2.8 amp battery/100-watt quartz halogen bulb
- XC385 features an internal, memory-free rechargeable battery with 15-20 minutes operating time on a full charge, comes with 110-volt and 12-volt charging cords, a 12-volt cord for continual powered operation
- XC408 operates from any standard 12V cigarette lighter receptacle



LIND EQUIPMENT

Model No.	Mfg. No.	Description	Price /Each
XC385	QR-2002	Cordless Rechargeable Spotlight	94.30
XC408	QH-2002	Corded Spotlight w/ 12V Plug	59.30

SIEGE® COMPACT LANTERNS

- C4 LED technology for extreme brightness
- A rugged, compact lantern
- 360° soft even lighting that illuminates a large area
- Multiple modes
- Stand it upright or to use as an overhead light hang it with the D-ring on base of lantern
- IPX7 waterproof to 1 m submersion
- 2 m impact resistance tested
- Floats so you can retrieve it if you drop it in the water
- Colour: Black/Green
- RoHS compliant
- Batteries not included



XD340



Model No.	Mfg. No.	Description	Beam Distance	Lumens High	Lumens Low	Run Time High	Run Time Low	Price /Each
XD340	44931	Lantern, 3 D-Cell Batteries	200 m	340	33	30	295	72.40
XB875	EN95	Replacement D-Cell Batteries, 12/Pkg.						21.70/Pkg.
XE647	44941	Lantern, 3 AA-Cell Batteries	100 m	200	50	7	37	54.60
XB872	EN91	Replacement AA-Cell Batteries, 24/pkg.						17.40/Pkg.

LED FLEX-NECK FLASHLIGHTS

- Work hands free in bright LED light; magnetic base attaches to any metal surface
- 15" flexible neck directs 65 lumens of bright LED light
- Aerospace grade aluminum no-slip body is hard anodized for extreme durability
- Push button on/off tail switch allows for easy operation
- 15 hours of burn time on 2 AA batteries (not included)



PELICAN™

Model No.	Mfg. No.	Description	Lumens	Price /Each
XC517	2365-010-110	LED Flex-Neck Flashlight	65	72.50
XB872	EN91	Replacement AA-Cell Batteries, 24/pkg.	-	17.40/Pkg.

HARD CASE® PROFESSIONAL SPOT LIGHTS

- High: 500 lumens; Low: 150 lumens
- LEDs produce a tight white spot light
- Intense focused beam
- High and Low modes for brightness and run time control
- Ideal for long distance applications and searching
- Shatterproof lens
- Water resistant
- Rugged construction
- Durable light survives drops up to 7 meters
- Run time: High 4 hrs., Low 20 hrs.
- Beam Distance: 425 m
- Material: Hard Plastic
- Colour: Black/Grey
- Includes 6 AA batteries

Model No. XE475
Mfg. No. HCSP61E
Price/Each \$42.20



REPLACEMENT BATTERY

Model No. XB872 - 24/pkg.
Price/Pkg. \$17.40

Energizer

HARD CASE PROFESSIONAL™ 2 AA LED FLASHLIGHTS

- 250 lumens
- Water resistant IPX4
- Shatterproof lens
- Impact resistant steel plate bolted sides
- Run time: High 5 hrs., Low 50 hrs.
- Includes 2 long lasting AA Energizer® alkaline batteries
- Beam distance: 105 meters

Model No. XC234
Mfg. No. TUF2AAPE
Price/Each \$22.20



REPLACEMENT BATTERY

Model No. XB872 - 24/pkg.
Price/Pkg. \$17.40

Energizer

HARD CASE PROFESSIONAL™ LED INSPECTION LIGHTS

- Bright Cree® 1/2 W LED delivers 100 lumens
- 4.5-hour run time on high power
- Shatterproof lens
- Water resistant IPX4
- Impact resistant rubber head and tail with no slip grip
- Lifetime push button switch
- Includes 2 long lasting AAA Energizer® alkaline batteries

Model No. XE676
Mfg. No. TUFPL22PH.H7
Price/Each \$19.30



REPLACEMENT BATTERY

Model No. XB873 - 24/pkg.
Price/Pkg. \$19.10

Energizer

ENERGIZER® 2AA PIVOTPRO FLASHLIGHTS

- Water Resistance Rating: IPX4
- Designed to last 25 years and backed by a full lifetime guarantee
- Custom designed optics deliver a wide, intense beam
- Head pivots 175° to aim light where it's needed
- Versatile design features a magnetic base & compact body
- Top quality construction and advanced LED technology
- Exceptionally durable and Weather-resistant
- Survives drops up to 7 meters and features a shatterproof lens
- Includes two Energizer® MAX® AA batteries
- Lamp Type: LED
- Lumens (High): 300
- Lumens (Low): 30
- Run Time Hrs. (High): 5.5
- Run Time Hrs. (Low): 30
- Material: Plastic
- Batteries Required: AA
- Colour: Black
- Beam Distance: 30 m
- Batteries included

Model No. XE886
Mfg. No. HCSW21E
Price/Each \$39.50



Energizer

HARD CASE® RUGGED LED WORK LIGHTS

- High: 350 lumens; Low: 150 lumens
- Rugged 6 LED work light with dual mode light output
- Includes a retractable rotating hook
- Magnets on the side
- Wide base for extra stability
- Survives 7 meter drops
- Shatterproof lens
- Run time: High 10 hrs., Low 40 hrs.
- Beam Distance: 100 m
- Material: Hard Plastic
- Colour: Black/Grey
- Includes 4 AA batteries

Model No. XE677
Mfg. No. HCAL41E
Price/Each \$40.70



REPLACEMENT BATTERY

Model No. XB872 - 24/pkg.
Price/Pkg. \$17.40

Energizer

HARD CASE PROFESSIONAL™ FLASHLIGHTS

- High: 250 lumens; Low: 80 lumens
- Water resistant IPX4
- 4 Nichia LEDs
- Shatterproof lens
- Impact resistant steel plate bolted sides
- Run time: High 10 hrs., Low 50 hrs.
- Includes 4 long lasting AA Energizer® alkaline batteries

Model No. XC235
Mfg. No. TUF4AAPE
Price/Each \$28.10



REPLACEMENT BATTERY

Model No. XB872 - 24/pkg.
Price/Pkg. \$17.40

Energizer

INDUSTRIAL LIGHTING

LED SMALL WALL PACKS

- Wall mount luminaire with a classic design
- Best suited for entrances, underpasses or anywhere controlled security lighting is required
- The tough die cast aluminum housing is moisture and dustproof
- High quality, long life LEDs
- 4KVAC surge protection included
- IP68 light engines with screw free structure
- IP67 drivers and waterproof connections
- Colour Temperature: 4000K • Colour: Bronze

XE769



STANPRO

Model No.	Mfg. No.	Voltage	Wattage	Lamp Output	Price /Each
XE769	WPS-LS1-W/40K	120-277 V	39 W	3605 Lumens	378.00
XE771	WPS-LS1-H/40K	347 V	39 W	3624 Lumens	456.00
XE770	WPS-LS2-W/40K	120-277 V	59 W	4720 Lumens	530.00
XE772	WPS-LS2-H/40K	347 V	59 W	4745 Lumens	606.00

LED MINI WALL PACKS

- High performance multi-purpose luminaire
- Effectively diffuses and distributes the highly efficient LED output to maximize spread while minimizing wattage consumption
- Best suited for security lighting over entrances, stairwells and pedestrian areas
- Polycarbonate housing and lens
- Integrated photocell
- High quality, long life LEDs
- Estimated lifespan of 50,000 hours
- 4KVAC surge protection included
- Colour Temperature: 5000K
- Colour: Bronze

XE764



STANPRO

Model No.	Mfg. No.	Voltage	Wattage	Lamp Output	Price /Each
XE764	WPI-LS1-W/50K/P	120 V	13 W	770 Lumens	158.00

LED LARGE FLOOD LIGHTS

- Powerful energy conserving floodlight
- Best suited for general lighting of grounds, storage yards, car dealers, parking areas and as floodlighting for signs and building fronts
- Made of die cast housing with a glass lens
- High quality, long life LEDs
- Estimated lifespan of 50,000 hours
- Fully sealed and gasketed for both upward and downward aiming
- Tamper proof screws come standard • IP65 rated
- 4KVAC surge protection included
- Colour Temperature: 4700K • Colour: Bronze

XE787



STANPRO

Model No.	Mfg. No.	Description	Voltage	Wattage	Lamp Output	Price /Each
XE787	FLD-L0105N3-W/47K	Narrow Beam	120 - 277 V	105 W	5697 Lumens	1228.00
XE788	FLD-L0105N3-H/47K	Narrow Beam	347 V	105 W	5697 Lumens	1313.00
XE789	FLD-L0105N5-W/47K	Medium Beam	120 - 277 V	105 W	5361 Lumens	1228.00
XE790	FLD-L0105N5-H/47K	Medium Beam	347 V	105 W	5361 Lumens	1313.00
XE791	FLD-LS1N7-W/47K	Large Beam	120 - 277 V	102 W	6755 Lumens	1228.00
XE792	FLD-LS1N7-H/47K	Large Beam	347 V	102 W	6755 Lumens	1313.00
XE793	FLD-LS2N3-W/47K	Narrow Beam	120 - 277 V	186 - 188 W	13880 Lumens	1492.00
XE794	FLD-LS2N3-H/47K	Narrow Beam	347 V	186 - 188 W	13880 Lumens	1577.00
XE795	FLD-LS2N5-W/47K	Medium Beam	120 - 277 V	186 - 188 W	15264 Lumens	1490.00
XE796	FLD-LS2N5-H/47K	Medium Beam	347 V	186 - 188 W	15264 Lumens	1577.00
XE797	FLD-LS2N7-W/47K	Large Beam	120 - 277 V	186 - 188 W	14765 Lumens	1490.00
XE798	FLD-LS2N7-H/47K	Large Beam	347 V	186 - 188 W	14765 Lumens	1577.00

HIGH BAY FLUORESCENT LUMINAIRES

- Best suited for high-ceiling warehouses as well as areas where uniform and efficient lighting is required
- Housing is made with 22-gauge rolled steel with enamel powder coating applied post-production
- Miro® 4 reflector has a high efficiency rating of 95%
- Comes standard with a set of hooks and can be installed with aircraft cables
- A 6 ft. white power cable is installed on the luminaire
- Easy ballast access from below
- Length: 50-1/4" • Lamp Type: T5HO
- Does not include fluorescent lamps



XE806

STANPRO

Model No.	Mfg. No.	Voltage	Wattage	Price /Each
4 LAMPS				
XE806	F1FB-4M4T5HO54-W	120 - 277 V	54 W	153.00
XE808	F1FB-4M4T5HO54-H	347 V	54 W	172.00
6 LAMPS				
XE807	F1FB-4M6T5HO54-W	120 - 277 V	54 W	193.00
XE809	F1FB-4M6T5HO54-H	347 V	54 W	203.00

FLUORESCENT LIGHT FIXTURES

- Sealed against water and moisture for wet and damp locations
- Uniform gasketing is inserted around the entire housing, ensuring a complete seal
- Polycarbonate housing and lens that are corrosion resistant and will not rot or rust
- Multiple conduit knockouts in housing ends and top
- Reinforced plastic lens latch clips
- UV stabilized, high clarity lens with prismatic cut-off
- Sealed strain relief/cable gland kit included
- 2 lamps
- Length: 50-1/4"
- IP65 rated
- Does not include fluorescent lamps

XE810



STANPRO

Model No.	Mfg. No.	Voltage	Wattage	Lamp Type	Price /Each
XE810	VT4F2T5HO054-W	120 - 277 V	54 W	T5HO	127.00
XE811	VT4F2T5HO054-H	347 V	54 W	T5HO	146.00
XE812	VT4F2T8032-W	120 - 277 V	32 W	T8	91.80
XE813	VT4F2T8032-H	347 V	32 W	T8	109.00

LED VAPOUR TIGHT LINEAR FIXTURES

- A luminaire ideal for a variety of industrial, commercial, vandal resistant and residential applications
- Can be installed inside or outside
- Lightweight, flexible and durable polycarbonate construction makes the luminaire vandal resistant and highly impact resistant
- The housing is sealed with a uniform gasket that blocks the ingress of moisture and dust and reinforced snap clips lock the luminaire together
- Multiple conduit knockouts in housing ends
- Sealed strain relief/cable gland kit included
- Length: 50-1/4" • Colour Temperature: 4000K
- IP65 rated



XE815

STANPRO

Model No.	Mfg. No.	Voltage	Wattage	Lamp Output	Price /Each
XE815	VT4-LS1-W/40K	120 - 277 V	40 W	3612 Lumens	250.00
XE816	VT4-LS2-W/40K	120 - 277 V	54 W	4936 Lumens	318.00
XE817	VT4-LS3-W/40K	120 - 277 V	75 W	6454 Lumens	369.00

STELLA EXIT SIGNS

- C860 approved
- Features 120/347 VAC dual input (hardwire) and universal DC; 6 - 24 VDC or self powered
- Uses 2 W LED board
- Long life LED light source
- Knockout chevrons
- 20-gauge steel construction with baked powder coat white paint finish
- Pre-stamped universal mounting and keyhole slots on backplate



XB930



XB933



Model No.	Mfg. No.	Description	Dimensions W" x D" x H"	Price /Each
XB930	SLE-SP-L-R-U-M	Exit	12 x 2.25 x 7.5	84.20
XB933	SLS-L-R-U-M-UDC	Sortie	18.5 x 2.25 x 7.5	129.00

STELLA RUNNING MAN EXIT SIGNS

- Feature 120/347 VAC dual input (hardwire), universal DC; 6-24 VDC or self-powered
- Running Man sign uses a 2 watt LED source
- Long life LED light source
- Universal pictograms included showing left indicators, right indicators and no indicators
- 20-gauge steel construction with white baked powder coat paint finish
- Pre-stamped universal mounting and keyhole slots on backplate

Model No. XE661

Mfg. No. SL-RM-L-U-0LR-M (AC)
Price/Each \$121.00

Model No. XE662

Mfg. No. SL-RM-SP-L-U-0LR-M (Self-powered)
Price/Each \$132.00

Model No. XE663

Mfg. No. SL-RM-L-U-0LR-M-UDC (6-24 VDC)
Price/Each \$121.00



XE661



TEMPESTA™ LED EMERGENCY LUMINAIRES

- Uses two LED modules that are wired in parallel
- Will only illuminate during a power failure
- LEDs are rated for 100,000 hours at L70
- Input Voltage: 120 - 347 V
- Wattage: 17 W
- High quality corrosion, flame and vandal resistant polycarbonate housing
- Comes standard with a Ni-MH battery pack that provides a minimum of 30 minutes of emergency lighting
- IP65 Rating



Model No.	Mfg. No.	Description	Dimensions L" x W" x H"	Price /Each
XE874	TA-LED-EM-120-347V-S	Surface Mounted	17 x 6 1/2 x 3 1/2	379.00
XE875	TA-LED-EM-120-347V-R	Recessed	19 1/4 x 9 1/2 x 3 1/2	494.00
XE876	TA-LED-EM-120-347V-TB	T-Bar Mount	23 3/4 x 7 1/2 x 4	494.00

STELLA COMBINATION SIGNS

- C860 approved
- LED EXIT and SORTIE models 120/347 VAC dual input (hard wire)
- Push button test switch
- Self-powered for minimum 30 minutes -6 VDC 36 W
- Solid state transfer charger
- Dual diagnostic LEDs indicate AC-ON and CHARGE
- Brownout and low voltage protection
- Two top mounted high impact thermoplastic PAR18 9 W tungsten heads
- Knockout chevrons
- 20-gauge steel construction with baked powder coat white paint finish



Model No.	Mfg. No.	Description	Price /Each
XB929	SLE-6-36-L-R-U-M-2SR/9W	Exit	175.00
XB932	SLS-6-36-L-R-U-M-2SR/9W	Sortie	174.00

REPLACEMENT BULB

XB338	LP104	9 W Tungsten	1.85
-------	-------	--------------	------

STELLA RUNNING MAN COMBO EXIT SIGNS

- Running Man models are supplied with 120/347 VAC dual input (hardwire)
- Push button test switch
- Self-powered for minimum 30 minutes - 6V DC 36W
- Solid state transfer charger
- Dual diagnostic LEDs indicate AC-ON and CHARGE
- Brownout and low voltage protection
- Two top mounted high impact thermoplastic PAR18 9-watt tungsten heads
- Universal pictograms included showing left indicators, right indicators and no indicators
- 20-gauge steel construction with white baked powder coat paint finish
- Certified for sale in Canada by an accredited certification body

Model No. XE664

Mfg. No. SL-RM-6-36-L-U-0LR-M-2SR/9W
Price/Each \$197.00



ILLUMINA® BS100 SERIES IP66 VAPOR-TIGHT

- Lightweight, durable 100% corrosion, flame and vandal resistant polycarbonate construction
- Designed to be resilient, highly efficient and easy to install
- For ceiling, wall, suspension and pendant installations
- UV stabilized to reduce the yellowing index
- Liquid silicone memory retention gasket allows for installations in wet locations
- Incorporates a "dual concave" parabolic high-output, metallized reflector
- Also approved for through wiring application



Model No.	Mfg. No.	Volts	Price /Each
XC441	BS10048T8232AC120V	120	127.00
XC442	BS10048T8232AC347V	347	144.00

EMERGENCY LIGHTS



NOVA EMERGENCY LIGHTING UNITS

- 120/277/347 VAC input
- Push button test switch
- Dual diagnostic LEDs indicate AC-ON and CHARGE
- Solid state transfer charger
- Brownout and low voltage protection
- Two top mounted high impact thermoplastic PAR18 9 W tungsten heads
- 20-gauge steel construction with baked powder coat white paint finish
- Pre-stamped universal mounting and keyhole slots
- Output 6 VDC or 12 VDC at rated wattage for 30 minutes
- Batteries included



XA440



XA439



XA190



Model No.	Mfg. No.	Replacement Batteries	Voltage Output	Watts Output				Price /Each
				1/2 hr.	1 hr.	1 1/2 hr.	2 hr.	
XA190	NV-636/2SR	XA604	6	36	18	12	9	127.00
XA438	NV-650/2SR	XB921	6	50	25	17	12	165.00
XA439	NV-680/2SR	XA605	6	80	40	26	20	190.00
XA440*	NV1272/2SR	XA604	12	72	36	24	18	218.00
XA441*	NV12120/2SR	XA605	12	120	80	65	25	309.00
XA442*	NV12150/2SR	XA605	12	150	80	65	40	333.00
XA443*	NV12180/2SR	XB922	12	180	100	60	45	400.00
XA444**	NV12250/2SR	XB922	12	250	125	83	62	449.00
XA445	NV12360/2SR	XA606	12	360	180	120	90	426.00
REPLACEMENT BULB			Description					
XB338	LP104			9 W Tungsten				1.85

* Two batteries required

** Three batteries required

NEMA12 EMERGENCY LIGHTING UNITS

- NEMA12 rated – water and dust tight units
- 120/277/347 VAC input
- Push button test switch
- Dual diagnostic LEDs indicate AC-ON and CHARGE
- Solid state transfer charger
- Brownout and low voltage protection
- Two top mounted, high impact thermoplastic PAR36 9 W weatherproof heads
- 20-gauge steel housing in industrial grey fibreglass finish
- Pre-stamped mounting holes
- Output 6 V or 12 VDC at rated wattage for 30 minutes
- Batteries included



SEG853



Model No.	Mfg. No.	Replacement Batteries	Voltage	Watts Output				Price /Each
				1/2 hr.	1 hr.	1 1/2 hr.	2 hr.	
SEG853	LDT-636/2LR-9w	XA604	6 VDC	36	18	9	0	387.00
SEG854	LDT-680/2LR-9w	XA605	6 VDC	80	40	20	10	499.00
SEG855*	LDT-1272/2LR-9w	XA604	12 VDC	72	36	18	9	652.00
REPLACEMENT BULB			Description					
XB338	LP104		9 W Tungsten				1.85	

* Two batteries required

SEALED LEAD ACID BATTERIES



Model No.	Mfg. No.	Description	Price /Each
XA604	BA-6-5.0BB	6 V, 5 Ampere-Hour	21.40
XA605	BA-6-12.0BB	6 V, 12 Ampere-Hour	28.20
XA606	BA-12-32.0BB	12 V, 32 Ampere-Hour	214.00
XB921	BA-6-7.2BB	6 V, 7.2 Ampere-Hour	22.10
XB922	BA-12-7.2BB	12 V, 7.2 Ampere-Hour	45.90



XA604

XB922

See page 870
for Glow in
the Dark Tape
& Markers



SUNNEX TASK LIGHTS

- Provide the concentrated light most needed for operations performed in today's workstations
- Ergonomically designed for ease-of-use and engineered to withstand years of operation

- Flexible gooseneck resists heavy vibration
- Scratch resistant PUR sleeving protects the flexible gooseneck arms from dust, oils, and moisture

Note: After selecting the desired lamp, select the desired base style from the mounting bases and accessories table at the bottom of the page.

20-WATT HALOGEN SERIES

- Compact head design allows positioning to provide the best lighting with minimal view obstruction

Standard features include: 12 V, 20 W halogen bulb, clear lens, spot reflector, black PUR gooseneck sleeving, 120 V power supply, On/Off switch , 7' SJT-18 polarized cord set

APPLICATIONS:

- Industrial manufacturing
- Assembly
- Inspection
- Medical and office

Model No.	Mfg. No.	Description	Price /Each
BW222	HS-700-20	20" Flexible Gooseneck, w/ built-in 120 V/12 V Transformer	306.00
BW223	HS-700-27	27" Flexible Gooseneck, w/ built-in 120 V/12 V Transformer	343.00
BW224*	HS-741-20	20" Flexible Gooseneck, 12 V, No Transformer	289.00
BW225*	HS-741-27	27" Flexible Gooseneck, 12 V, No Transformer	195.00
BW226	28610	120 V/12 V Protective Transformer	391.00

* These units can be wired directly into machinery power supply.



BW223 Lamps

BW232 Base (optional)

BW233 Base (optional)

50-WATT MOISTURE RESISTANT HALOGEN TASK LIGHTS

Moisture proof lamp head, lens, and reflector, make the light fixture suitable to any environment, without risking electrical damage to the lamp, or injury to the operator

Standard features include: 12 V, 50 W halogen bulb, clear lens, flood reflector, black PUR gooseneck sleeving, 110 V power supply, On/Off switch located on transformer base, 7' SJT-18 polarized cord set.

APPLICATIONS:

- Industrial machinery (CNC lathes, drill presses, grinding, milling and other high vibration shop machinery)
- Assembly workstations
- Workbenches



BW227 Lamps

BW232 Base (optional)

BW231 Base (optional)

Model No.	Mfg. No.	Description	Price /Each
BW227	HF2000-27	27" Flexible Gooseneck, w/ built-in 120 V/12 V Transformer	522.00
BW226	28610	120 V/12 V Protective Transformer	391.00

MOUNTING BASES & ACCESSORIES



BW231

BW232

BW233

Model No.	Description	Price /Each
BASES		
BW231	Magnetic Base	115.00
BW232	C-Clamp Bracket, 1 5/8" Opening	117.00
BW233	8" Round Table Base	144.00

Model No.	Description	Price /Each
REPLACEMENT BULBS		
BW234	12 V-20 W Replacement Halogen Bulb	17.70
BW235	12 V-35 W Replacement Halogen Bulb, Medium Flood	26.90
BW236	12 V-50 W Replacement Halogen Bulb	13.10
BW237	24 V-20 W Replacement Halogen Bulb	22.30
BW239	24 V-50 W Replacement Halogen Bulb	36.70
XC854	3.2 W LED Replacement Bulb	131.00



700 SERIES LED LIGHTING

The LED element offers a significant increase in luminous intensity of a standard 20-watt halogen bulb, while providing close to 70% less energy consumption, cool-touch heat management and a projected 25 000 hours of high-output lighting.

FEATURES INCLUDE:

- Compact 3.2 W LED lamp head with 340° rotation 90° bend
- Flexible gooseneck
- Exceptionally long element life (35 000 hours)
- Cool operating temperature
- Push button On/Off switch in head

APPLICATIONS

- Medical
- Assembly
- Visual Inspection
- OEM Applications
- Fine Assembly
- Industrial Manufacturing
- Office
- Bench Work
- Electronics
- Packaging

Model No.	Mfg. No.	Description	Price /Each
XC850	LS710-20	20" Flexible Gooseneck, Tall Base, Built in 120 V Transformer	435.00
XC851	LS710-27	27" Flexible Gooseneck, Tall Base, Built in 120 V Transformer	445.00
XC852	LS751-20	20" Flexible Gooseneck, Square Base, 12 V	409.00
XC853	LS751-27	27" Flexible Gooseneck, Square Base, 12 V	450.00



TASK LIGHTS & MAGNIFIERS

FLUORESCENT INDUSTRIAL-DUTY MAGNIFIERS

KFM SERIES

- Patented internal 45" spring arm offers perfect balance and full adjustability
- 5" diameter, distortion-free lens
- Reflector optimizes light output and distributes illumination evenly across the work area
- Electronic ballast increases light output by 15%
- Secondary lens allows for a wide variety of magnification tasks
- 22 W circline fluorescent bulb (included) is protected by a non-yellowing acrylic, splash guard/diffuser
- Colour: Light grey
- 5-year limited warranty

Model No. XB951 3-diopter (1.75x)

Price/Each \$479.00

Model No. XC617 5-diopter (2.25x)

Price/Each \$495.00



LUXO

MAGNIFIERS

IFM SERIES

- Ideal light-duty illuminated magnifier
- 5" diameter distortion-free lens in either 3-diopter (1.75x) or 5-diopter (2.25x) models
- 45" arm length
- Clamp or base mounts
- 22 W fluorescent tube which provides shadow-free illumination
- Built-in starter, the switch does not have to be held down for several seconds to illuminate the tube
- 115 V AC
- Colour: Light grey
- Includes: Lamp diffuser cover, 3-wire cord, 22-watt fluorescent tube
- Certified for sale in Canada by an accredited certification body



LUXO



XB947



XC227

Model No.	Mfg. No.	Arm Length"	Diopter	Mount type	Price /Each
XB947	16345LG	45	3D	Edge	449.00
XC225	16346LG	45	5D	Edge	459.00
XC227	16351LG	30	3D	Base	519.00

18 W ENERGY EFFICIENT FLEXIBLE DESK LAMP

- Gives equivalent light output to a 100 W incandescent
- Arm and head are uniquely flexible to allow for precise light placement
- Height 18"
- Base 6" x 9"
- Bulb: Max. 18 W mini fluorescent (DS 18 W – included)

Model No. XC792

Mfg. No. ULT118-BK

Price/Each \$178.00



RHINOMAG ILLUMINATED FLUORESCENT MAGNIFIERS

- 5" diameter, 3-diopter lens which magnifies 1.75x (for increased magnification, see auxiliary lenses below)
- Heavy-duty spring balanced arms extend 42" (107 cm)
- Instant on/off switch
- Bulb cover for safety
- Comes with 22 W circline fluorescent bulb, spring covers and an industrial duty clamp-on bracket "A"

Model No. XC510 White

Price/Each \$189.00

Model No. OM135 Black

Price/Each \$189.00



XC510



AUXILIARY LENSES

Model No.	Description	Price /Each
XC512	5 diopter lenses, replaces supplied 3D lens	38.40
XC995	Replacement fluorescent bulb	14.50

CLIP-ON GOOSENECK LAMP

- Flexible, gooseneck arm
- Adjustable height
- Line switch on/off
- Overall Dimensions: 19" H x 3" D
- Mounting Type: Clamp
- Bulb Type: Halogen
- Lamp Wattage: 50 W
- Bulb not included



Model No.	Mfg. No.	Colour	Price /Each
XE733	DGU16-0BB	Brushed Bronze	89.10
XE734	DGU16-5C	Satin Chrome	89.10
50 W HALOGEN GU10			
XC568	B7462	-	2.68

SWING ARM CLAMP-ON DESK LAMPS

- Spring arm adjusts to many positions
- 36" reach
- Clamp to any surface
- Durable baked enamel finish
- Uses CFL bulbs (not included)
- Certified for sale in Canada by an accredited certification body



Model No.	Frame Colour	Light	Type	Price /Each
XA982	Black	23 W	CFL	57.60
XA983	White	23 W	CFL	57.30

REPLACEMENT BULBS

Model No.	Light	Price /Each
XC552	23 W	13.40

INDUSTRIAL TROUBLE LIGHTS

- 75 watts
- Lightweight design
- Rugged impact resistant housing
- Grounded 25' cord
- On/Off switch handle
- **Includes:** Hanging hook and electric outlet
- Certified for sale in Canada by an accredited certification body

Model No. XC660
Price/Each \$32.25

aurora tools®



INDUSTRIAL FLUORESCENT WORK LIGHTS

- Cool running fluorescent bulb included
- Shatter resistant polycarbonate lamp shield
- Includes: full length reflector, switch and hook
- Models **XB906**, **XB907** and **XB967** also have a magnet mount and outlet
- Certified for sale in Canada by an accredited certification body



LIND EQUIPMENT

Model No.	Description	Length*	Price /Each
COMPACT TWIN-TUBE			
XB906	13 W, 25' Cord, 16/3 SJT	13	57.90
XB907	13 W, 50' Cord, 16/3 SJT	13	80.10
XB967	26 W, 25' Cord, 16/3 SJT, Dual Twin-Tube	15	81.90
XA251	Replacement Bulb, Rough Service (for XB906 and XB907)	-	12.80
XC409	Replacement Bulb (for XB967)	-	8.01
LINEAR FLUORESCENT			
XB968	15 W, 25' cord, 18/2 SJT	26	71.90

RECHARGEABLE FLUORESCENT WORK LIGHTS

- Utilises a long lasting fluorescent bulb which delivers excellent light in a highly portable package
- 13 W cool operating • 900 lumens
- Rechargeable 7.2 V NiMH battery pack
- 90-minute run time with full charge
- Convenient rotating hanging hook
- Stands upright on its base
- Extra battery pack allows continuous use of the light while the other is charging (Model No. **XC419**)
- **Includes:** Battery pack, 120 V charging cradle and 12 V auto adaptor cord
- Certified for sale in Canada by an accredited certification body



LIND EQUIPMENT

Model No.	Description	Price /Each
XC418	13 W Rechargeable Fluorescent Work Light	127.00
XC419	Spare Battery Pack for XC418	46.20
XC470	Replacement Bulb for XC418	16.10

INDUSTRIAL WORK LIGHTS

INCANDESCENT WORK LIGHTS

- Grounded convenience outlet
- On/Off switch handle
- Models **XA175**, **XA918**, **XB987** and **XB988** feature a circuit breaker
- Models **XB987** and **XB988** feature a cord that stays flexible in cold temperature
- Certified for sale in Canada by an accredited certification body
- Accepts up to 100-watt incandescent or CFL bulb



LIND EQUIPMENT

Model No.	Description	Price /Each
XA175	25' Cord, 14/3 SJTW, 15 A	60.30
XA918	50' Cord, 14/3 SJTW, 15 A	91.00
XB987	25' Cord, 16/3 SJTWO, All Temperature, 13 A	42.80
XB988	50' Cord, 16/3 SJTWO, All Temperature, 13 A	64.40
XB990	50' Cord, 16/3 SJT, 13 A	53.70
XB123	Replacement Bulb	3.43

VAPOUR-PROOF INCANDESCENT WORK LIGHTS

- Suitable for areas where water vapour is present
- Rated for a 100 W incandescent or CFL bulb
- Impact resistant glass globe and metal guard
- Oil resistant yellow rubber handle
- 16/3 SOOW cord
- Certified for sale in Canada by an accredited certification body

Note: Not submersible

Model No. XA270 25' cord **Price/Each \$443.00**

Model No. XA267 50' cord **Price/Each \$487.00**

Model No. XB123 Replacement bulb **Price/Each \$3.43**



LIND EQUIPMENT

HEAVY-DUTY FLUORESCENT WORK LIGHTS

- Cool running and protected by a rugged, shatter-proof polycarbonate tube
- Includes an enclosed starter switch, rubber end caps, full-length reflector and hanging hook
- Moisture and dust resistant
- Yellow 18/2 SJTOW cord
- Vapour-proof work lights suitable for areas where water vapour is present
- Certified for sale in Canada by an accredited certification body



LIND EQUIPMENT

Model No.	Description	Cord Length'	Price /Each
TWIN-TUBE, COMPACT			
XA146	13 W, 900 Lumens	25	118.00
XB971	13 W, 900 Lumens	50	140.00
XA251	Replacement Bulb, Rough Service	-	12.80
LINEAR TUBE			
XA149	15 W, 920 Lumens	25	136.00
XB972	15 W, 920 Lumens	50	162.00
XB973	25 W, 2200 Lumens	25	275.00
XB974	25 W, 2200 Lumens	50	313.00
VAPOUR-PROOF			
XC330	13 W, 900 Lumens	25	150.00
XC331	13 W, 900 Lumens	50	178.00
XA251	Replacement Bulb, Rough Service	-	12.80

WORK LIGHTS & CORD REELS

LED WORK LIGHTS

- Latest in LED technology brings bright, long-lasting and energy-efficient lighting to your toughest tasks
- Cool running, cold-temperature operable and highly energy efficient
- Bright white LED's provide extremely long lamp life (50 000 hours average)
- 50 LED, 15' 16/3 SJT cord, 13 A grounded outlet, removable magnet mount and dual hooks
- **Includes:** On/off switch, hanging hook and focused reflector
- Certified for sale in Canada by an accredited certification body

Model No. XC413
Price/Each \$117.00



LIND EQUIPMENT

RECHARGEABLE LED WORK LIGHTS

- Cool running, cold-temperature operable, and highly energy efficient
- Bright white LED's provide extremely long lamp life (50 000 hours average)
- Dual-stage switch provides two brightness levels
- NiMH battery operates 3-4 hours on high, and 7-8 hours on low setting
- **Includes:** Low-battery indicator, carrying case and charging cradle with battery monitor
- Certified for sale in Canada by an accredited certification body



LIND EQUIPMENT

Model No.	Description	Price/Each
XC417	48 LED Rechargeable Light with Carrying Case	142.00

HAZARDOUS LOCATION WORK LIGHTS

INCANDESCENT HAND LAMPS

- 100-W explosion proof light provides 1600 lumens of light output
- 16/3 SOOW cord with a non-explosion proof plug (explosion proof plug is also available)
- Approved for Class I Division I Group C and D hazardous locations
- Certified for sale in Canada by an accredited certification body

25' CORD

Model No. XA269
Price/Each \$786.00

50' CORD

Model No. XA103
Price/Each \$828.00

100' CORD

Model No. XD059
Price/Each \$909.00

REPLACEMENT BULB

Model No. XB123
Price/Each \$3.43



COMPACT FLUORESCENT HAND LAMPS

- 26-W quad tube (1800 lumens)
- Minimal heat generation makes them ideal for use in confined, potentially explosive areas
- DuPont Zytel® outer construction is extremely rugged and leaves no exposed metal parts
- 16/3 SOOW cord with a non-explosion proof plug (explosion proof plug is also available)
- Approved for Class I Division 1 Group C and D and Class II Division 1 Group F and G hazardous locations
- Certified for sale in Canada by an accredited certification body



Model No.	Description	Price /Each
XA137	26 W, 25' Cord	1132.00
XA136	26 W, 50' Cord	1169.00
XD060	26 W, 100' Cord	1319.00
XD061	Replacement Bulb 26 W Quad Tube	23.10

LED HAZARDOUS LOCATION FLOODLIGHTS

- Ultra bright 39 W LED array
- Equivalent usable light output as a 70 W metal halide hazardous location floodlight while using 56% less energy
- Aluminum housing can stand up to rough service and is suitable for wet locations (NEMA 4)
- Includes 50' 16/3 SOOW cable and standard plug (explosion-proof plug is also available)
- Approved for use in Class I, Division 1, Groups C&D, Class II, Division 1&2, Groups F&G and Class I, Division 2, Groups A, B,C&D hazardous locations
- Certified for sale in Canada by an accredited certification body

Model No. XD051
Price Each \$3788.00



LIND EQUIPMENT

RECHARGEABLE LED WORK LIGHTS

- 90 and 160 super bright LED lights
- Lightweight design
- Rugged impact resistant housing
- 3-4 hour run time on full charge
- Includes: Hanging hook, powerful magnet, 110 V adaptor and 12 V car plug
- Certified for sale in Canada by an accredited certification body



Model No.	No. of LED	Price/Each
XC661	90	80.30
XC662	160	96.90

RECHARGEABLE LED WORK LIGHTS

- 26 super bright LED lights
- 3-4 hour run time with full charge
- Includes: 110 V adaptor and 12 V car plug
- Certified for sale in Canada by an accredited certification body

Model No. XC663
Price/Each \$53.80



Can't find what you're looking for?

Call us today!

HAND-HELD & PORTABLE FLOOD LIGHTS

- 500-watt weatherproof fixture
- 8', 16-gauge heavy-duty cord
- Comfortable foam grip (XA143 and XA145)
- Screw-type clamp mounts light anywhere you need it, including ladders or scaffolding (XA143)
- Lights up to 5000 sq. ft.
- **Model XA145:** Powerful 40 lbs. pull strength magnet quickly attaches to metal surfaces
- **Model XA638:** PVC coated solid steel base
- Certified for sale in Canada by an accredited certification body



Model No.	Description	Price /Each
XA143	Hand-Held Flood Lights with Clamp	173.00
XA145	Hand-Held Flood Lights with Magnet	173.00
XA638	Industrial Portable Flood Lights	185.00
XC464	Replacement Bulb	1.53

BEACON 360° WIDE AREA LED LIGHT

- Light temperature: 4500K (bright white light - no blue tint)
- 13000 lumens equivalent usable light of a 400 W metal halide
- Environmental rating: IP64 (weatherproof)
- Construction: Cast aluminum housing, polycarbonate lenses
- Switch: On/Off rocker switch
- Weight: 10 lbs. (light head only)
- Height: 14" (light head)
- Diameter: 6" (light head)
- 120 W
- Lighting range: 50'
- Approvals: cETLus portable work light



Model No.	Description	Price /Each
XE636	W/Magnet Mount	1199.00
XE637	W/Clamp	1149.00
XE638	W/Tripod	1199.00

BEACON LED FLOODLIGHTS

- 50 W as bright as a 500 W quartz-halogen floodlight
- 30 W as bright as a 300 W quartz-halogen floodlight
- Low operating temperature, resulting in a safer working environment
- Low energy usage and no bulb replacement, resulting in large total cost of ownership savings
- High quality LEDs are rated for over 50000 hours
- Durable aluminum housing and tempered glass lens
- IP65 environmental rating and starts instantly in cold weather
- 15' 18/3 SJOW cord
- Certified for sale in Canada by an accredited certification body



Model No.	Description	Price /Each
FLOODLIGHTS		
XE855	50 W LED Floodlight Base Model	452.00
XC942	50 W LED Floodlight with Floor Stand	499.00
XC941	50 W LED Floodlight with Tripod	569.00
XD044	50 W LED Dual Head Floodlight with Tripod	1166.00
XD045	50 W LED Floodlight with Magnet Mount	613.00
XD046	50 W LED Floodlight with Clamp Mount	504.00
XE856	30 W LED Floodlight Base Model	319.00
XE857	30 W LED Floodlight with Floor Stand	383.00
XE858	30 W LED Floodlight with Tripod	458.00
XE859	30 W LED Dual Head Floodlight with Tripod	946.00
XE860	30 W LED Floodlight with Magnet Mount	458.00
XE861	30 W LED Floodlight with Clamp Mount	398.00
RECHARGEABLE FLOODLIGHTS		
XE862	30 W LED Rechargeable Floodlight Base Model	360.00
XE863	30 W LED Rechargeable Floodlight with Floor Stand	423.00
XE864	30 W LED Rechargeable Floodlight with Tripod	499.00
XE865	30 W LED Rechargeable Dual Head Floodlight with Tripod	859.00
XE866	30 W LED Rechargeable Floodlight with Magnet Mount	499.00
XE867	30 W LED Rechargeable Floodlight with Clamp Mount	438.00



WORK LIGHTS & CORD REELS

TWIN HEAD HALOGEN WORK LIGHTS

- Twin 500-watt halogen lights
- Heat resistant tempered glass face
- Adjustable tripod for desired height
- Extendable tripod legs provide greater stability
- Colour: Black and yellow
- Halogen bulbs included
- Certified for sale in Canada by an accredited certification body



Model No. XC950
Price/Each \$76.60

REPLACEMENT BULB
Model No. XC951
Price/Each \$1.90

aurora tools

PORTABLE HALOGEN WORK LIGHTS

- 500-watt halogen work light
- Heat resistant tempered glass face
- Adjustable tilting head
- Colour: Black and yellow
- Halogen bulb included
- Certified for sale in Canada by an accredited certification body



Model No. XC949
Price/Each \$26.75

REPLACEMENT BULB
Model No. XC951
Price/Each \$1.90

aurora tools

LINEAR FLUORESCENT LED STRINGLIGHTS

- 50 W fluorescent lamp is rated for 14 000 hours, equivalent light output as a 300 W incandescent lamp
- Hangs 14" high with hooks
- 16/3 SJTOW cord
- Thick-walled polycarbonate outer tube is virtually indestructible
- Oversized end caps provide additional impact protection
- Feed-through receptacle allows lights to be strung together to light larger areas (up to 24 units)
- Moisture and dust resistant
- Certified for sale in Canada by an accredited certification body



LIND EQUIPMENT

Model No.	Description	Price /Each
XD063	35", 50 W Linear Fluorescent	616.00
XD064	35", 50 W Linear Fluorescent/Vapour Proof	655.00
XE854	35" LED Stringlights	873.00

HEAVY-DUTY WORKLIGHTS

- 500-watt weatherproof fixture
- Tempered glass lens
- Chrome-plated, solid steel guard
- Shock-resistant double insulated wiring
- 500 W colour-corrected quartz halogen bulb included
- Powder-coated steel construction
- Rubber leg tips protect floors and surfaces
- Certified for sale in Canada by an accredited certification body

REPLACEMENT BULB
FOR ALL THREE STYLES
Model No. XC464
Price/Each \$1.53

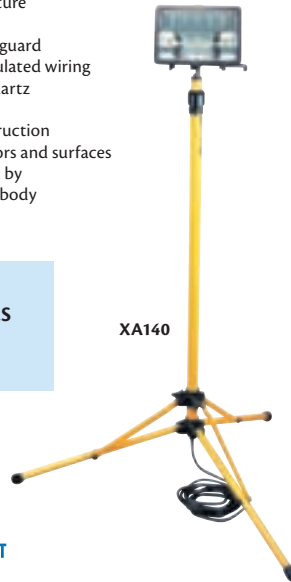

XA140

LIND EQUIPMENT

1' TO 3' TELESCOPIC

- 8', 16-gauge heavy-duty chemical and abrasion resistant cord
- Collapsible steel base
- Lights up to 6000 sq. ft.

Model No. XA150
Price/Each \$181.00

4' TO 8' TELESCOPIC

- Double-reinforced sandbaggage steel base expands to 48"
- 15', 16-gauge heavy-duty chemical and abrasion resistant outdoor cord
- Lights up to 7000 sq. ft.

Model No. XA140
Price/Each \$270.00

4' TO 8' TELESCOPIC TWIN

- Twin 500-watt heads
- Fixtures independently adjustable 360°
- Two 10 A switches
- Double-reinforced sandbaggage steel base expands to 48"
- 15', 16-gauge heavy-duty chemical and abrasion resistant cord
- Lights up to 14 000 sq. ft.

Model No. XA141
Price/Each \$408.00

ENERGY EFFICIENT FLUORESCENT FLOODLIGHTS

- 65 W cool-running, energy efficient fluorescent floodlight
- Light output equivalent to 300 W incandescent but with much less energy use
- Aluminum frame, tempered glass lens
- Energy Star® certified

Model No. XC469
Price/Each \$104.00



LIND EQUIPMENT



LED WORK LIGHTS

- LED bulbs last longer than Halogen, consumes less energy
- Stays cool to the touch even after hours of usage
- Impact resistant glass and durable aluminum housing
- Weather-protected sealed switch
- Non-slip soft grip carry handle
- For indoor and outdoor use in dry locations
- XE665: Twin LED lights easily detach from tripod
- XE665: Unit includes tripod stand and (2) 2,400 lumen LED lights



Model No.	Lumens	Wattage	Lighting Range	Price /Each
XE666	2400	20 W	70'	64.60
XE665	4800	40 W	140'	158.00

HEAVY-DUTY MOLDED LED STRINGLIGHTS

- Rugged 12/3 or 12/2 STW cable is high visibility yellow
- Can be linked together for longer runs
- Sockets are rated for a max. 120 V, 150 W A23 bulbs
- Certified for sale in Canada by an accredited certification body



XB979



XE853

LIND EQUIPMENT

Model No.	Length'	Wire Type	No. of sockets	Guard Style	Price /Each
XB979	50	12/3	5	Plastic Cage	115.00
XB980	50	12/3	5	Metal Cage	132.00
XE852	50	12/3	5	Polycarbonate LED Lamp Array	561.00
XB981	100	12/3	10	Plastic Cage	225.00
XB982	100	12/3	10	Metal Cage	256.00
XD062	100	12/2	10	Plastic Cage	164.00
XE853	100	12/3	10	Polycarbonate LED Lamp Array	946.00

ACCESSORIES

Model No.	Description	Price/Each
XB119	Standard Coat Replacement Bulb	2.92
SA0746	Replacement Plastic Head	4.91
SA0747	Replacement Metal Head	14.00

WOBBLELIGHT® SELF-RIGHTING WORK LIGHTS

Bright and dependable, the self righting Wobblelight® delivers maximum light output in a highly durable and portable package with no hot surfaces.

- Ideal anywhere temporary high-output lighting is needed, such as indoor and outdoor construction sites, manufacturing, plant maintenance, fire & rescue
- Floating shock system protects bulb from impact
- Counter-weighted self righting design
- 360° lighting out put adjustable to 180° with optional reflector
- Optional nylon reflector shield allows you to maintain 100% light source and focus it
- Internal ventilation system keeps light cool to the touch
- No set up – plugs into 120 VAC supply
- Available in 27" and 36" Heights
- Model **XC332**, **XC334** & **XE603** include receptacle for connecting units in a series
- Certified for sale in Canada by an accredited certification body



XC746



XC332

Model No.	Mfg. No.	Description	Light Output Lumens	Lighting Area	Price /Each
XC746	WL85F	85 W Fluorescent, 27" High	5000	20'	266.00
XC332	WL175MH	175 W Metal Halide, 36" High	15 000	30-42'	541.00
XC334	WL400MH	400 W Metal Halide, 36" High	40 000	78-110'	649.00
XE603	11136LED	65 W LED, 36" High	5500	30'	1367.00

ACCESSORIES

Model No.	Mfg. No.	Description	Price/Each
XC747	WL62230	180° Arc Reflector Shield for XC746	47.40
XC335	WL52230	180° Arc Reflector Shield for XC332, XC334 & XE603	47.40
XC749	111810	Replacement Transparent Dome w/Cap for XC746	78.30
XC453	111801	Replacement Transparent Dome w/Cap for XC332, XC334 & XE603	86.60

REPLACEMENT BULBS

XC748	WL62260	Replacement Bulb for XC746	61.80
XE706	64030	Replacement Bulb for XC332	23.90
XC454	M400/U/ET18	Replacement Bulb for XC334	27.00
XE532	111965	Replacement Bulb for XE603	471.00



XC335

Arc Reflector Shield

DEFENDER® ECO UPLIGHTS

- Tripod base
- Available in a two foot or four foot versions
- Integrated and collapsible legs opening up to 30" diameter for exceptional stability
- Tripod base is collapsible and locking
- IP44 design for dust and water resistance
- 15-ft. power cord
- Adjustable nylon carrying strap
- Removable threaded hooks for hanging
- Low energy consumption
- Lamp life of 20 000 hours
- Removable reflector for 360° lighting
- Certified for sale in Canada by an accredited certification body



XC753



Model No.	Mfg No.	Description	Light Output Lumens	Lighting Area	Price /Each
XC752	E712605	Tripod Base, 18 W Fluorescent, 2' High	1300	5- 10'	229.00
XC753	E712600	Tripod Base, 36 W Fluorescent, 4' High	3250	10-15'	261.00

MINI MOBI LED INSPECTION LIGHTS

- 20 LEDs deliver 55 lumens
- Wide spread beam of clean white light
- Tough ABS body, rubber over-mold and shatterproof lens
- Integrated floor stand, hanging hook and magnet offer multiple working positions
- Run time: 3 hours (high) – 8 hours (70% power)
- Includes 3 AA batteries
- Ideal for: Construction, industrial, maintenance industries

Model No. XD067
Mfg. No. E712848

Price Each \$34.00 REPLACEMENT BATTERIES

- AA, alkaline batteries, 24/pkg.
- Model No. XB872
Price/Each \$17.40



HANG-A-LIGHT® WORK LIGHTS

The Hang-A-Light® is a high-output temporary lighting fixture that gives 360° light with low-cost operation.



HANG-A-LIGHT® FLUORESCENT

- Energy efficient 105 watt fluorescent bulb
- Self-ballasted CFL bulb, lightweight and flicker-free
- Lumens: 6900
- Lighting area: 20-30'
- Electrical receptacle, interconnect up to 8 units on a 120 V/15 A service
- 5' integrated power cord
- Certified for sale in Canada by an accredited certification body

HANG-A-LIGHT®

- Modifiable for 120/208/240/277 V
- Heavy-gauge steel construction
- Lumens: 42 000
- Lighting area: 50-100'
- Spring-loaded steel safety hook for fast installation
- Welded wire safety cage with bottom guard
- Lights 60' radius when mounted 15' above work area
- NEC/OSHA compliant
- Suitable for damp location use
- 6' integrated power cord
- Certified for sale in Canada by an accredited certification body

HANG-A-LIGHT® TEMPORARY AREA LED LIGHT

- Portable LED lamp that is ideal for use in many different work environments
- Can be interlinked with other units
- Spring loaded clamp makes hanging the unit easy
- Has a 5' integrated power cord
- No hot surfaces
- Lumens: 5500
- Lighting Range: 30'
- Lamp Life: 30000 hrs.
- Certified for sale in Canada by an accredited certification body



ProBUILT Professional Lighting, LLC

WOBBLIGHT

Model No.	Mfg. No.	Description	Price /Each
XC754	111105F	Hang-A-Light®, 105 W Fluorescent	200.00
XD065	111400PS	Hang-A-Light®, 400 W Pulse Start Metal Halide	263.00
XE602	111065LED	Hang-A-Light®, 65 W Portable LED lamp	748.00
XC755	111915	Replacement Bulb for XC754	103.00
XD066	111903PS	Replacement Bulb for XD065	74.20
XE532	111965	Replacement Bulb for XE602	471.00

9430 REMOTE AREA LIGHTING SYSTEMS

- Up to 15 hours of burn time
- High flux LED, 50000 hour life
- 1500 lumens at low setting
- 3000 lumens at high setting
- Maintenance-free LED array with life expectancy of 50000 hours
- Fully extendable mast with 360° rotating head
- 12 V rechargeable, sealed battery
- Battery run time: 15 hours at low setting, 8 hours at high setting
- Battery charge time: 5 hours from full discharge
- Low battery warning system
- Waterproof rubber activation switch
- Mast extension lock
- Certified for sale in Canada by an accredited certification body

Model No. XC817
Price/Each \$1263.00



9460RS REMOTE AREA LIGHTING SYSTEMS

WIRELESS ACTIVATION

- High flux LED, 50000 hour life
- 500 lumens at low setting
- 6000 lumens at high setting
- Two lamp heads with six LEDs per head
- 120° beam spread
- 12 V rechargeable, sealed battery
- Battery run time: 40 hours at low setting, 7 hours at high setting
- Battery charge time: 6 hours from full discharge
- Features two remote control activation devices, multi-terrain trolley, a 12 V power supply port
- Remote control devices can be used 60' away
- Certified for sale in Canada by an accredited certification body

Model No. XC818
Price/Each \$2779.00



9480 REMOTE AREA LIGHTING SYSTEMS

- Lighting system with 3 preset output levels (1000, 3000 or 4000 lumens)
- Includes a mast with an extended height of 23.75" and 340° rotation
- Very versatile system with multiple deployment positions
- Maintenance free LED array with 50000 hour life expectancy
- Includes a convenient shoulder strap
- Uses a 12 V rechargeable Sealed Lead Acid (SLA) battery
- Battery lasts between 6 and 28 hours depending on which output level is used
- Lighting range is highly variable and depends on the system's set-up
- Lamp Type: High Flux LED
- Wattage: 41.1 W
- Lamp Life: 50000 hrs.
- Housing Material: Polypropylene
- Certified for sale in Canada by an accredited certification body

Model No. XE696
Price/Each \$1070.00



WORK LIGHTS & CORD REELS

HAND-WIND ELECTRIC CABLE REELS

- Provides a portable power centre for tools and equipment
- Frame is made from heavy-duty steel tubing, and features a contoured comfort grip
- Side discs are rolled to provide increased rigidity and strength
- Powder painted for a long-lasting, tough finish
- Equipped with four 120 V 15/20 A T-slot receptacles and 120 V 15 A plug
- LED illuminates to indicate that the reel is connected to power
- Resettable circuit breaker protects against overloads
- Receptacles are recessed for protection against impact and inadvertent contact
- Enclosed terminals at the centre of the reel hub prevent users from contacting live connections
- Dimensions: 17 1/2" L x 11 1/2" W x 18" H
- Certified for sale in Canada by an accredited certification body



LIND EQUIPMENT

Model No.	Description	Price /Each
XC410	10" Pigtail, Ready for Winding Your Existing Extension Cord	256.00
XC411	Reel w/ 100' 12/3 S00W Cord w/ Plug	576.00
XC412	Reel w/ 50' 12/3 S00W Cord w/ Plug	410.00

LE9000 SERIES HEAVY-DUTY CORD REELS

- Durable all-steel weatherproof construction, NEMA4 weatherproof rating
- Adjustable cable guide arm (12 positions)
- Strong ratchet can be disengaged for constant tension
- Adjustable ball stop
- 6' feeder cord
- Standard SJOW or SOW cable
- Approvals: CSA, UL



LIND EQUIPMENT

Model No.	Cord Length'	Description	Rating	Price /Each
XC736	30	14/3 SJOW Incandescent Light	15 A	1017.00
XC737	30	14/3 SJOW Single Outlet (5-15R)	15 A	935.00
XC739	30	14/3 SJOW Quad-Box (5-15R)	15 A	1026.00
XC741	50	14/3 SJOW Incandescent Light	15 A	1077.00
XC742	50	14/3 SJOW Single Outlet (5-15R)	15 A	987.00
XC743	50	12/3 SJOW Single Outlet (5-20R)	20 A	1123.00
XC744	50	14/3 SJOW Quad-Box (5-15R)	15 A	1085.00
XC745	50	12/3 SJOW Quad-Box (5-20R)	20 A	1185.00

LED WORK LIGHT REELS

- Reach your light to where you need it most, with 30 or 50 feet of cable
- Bright white LED's on lights last for an average of 50000 hours
- Tough metal reel housing stands up to abuse
- Certified for sale in Canada by an accredited certification body



LIND EQUIPMENT

Model No.	Description	Price /Each
XC414	30' of 16/3 SJTW Cord, 50-LED Work Light w/10 A Outlet	176.00
XE891	50' of 18/2 SVT Cord, 34-LED Work Light	173.00

MEDICAL & DATA CORD REELS

LE6500 SERIES INDUSTRIAL CORD REELS

- Weatherproof (NEMA 4X) construction
- Compact and lightweight design
- Ideal in areas where a heavy-duty cord reel is too large or expensive
- Available with up to 30' of cord
- XD054 and XD055 include hospital grade outlets
- Certified for sale in Canada by an accredited certification body



LE2300 SERIES RETRACTABLE DATA REELS

- Robust spring technology
- Compact and lightweight design
- Ideal in conference rooms or other areas where instant data connections are required without the mess of stray wires
- Certified for sale in Canada by an accredited certification body



LIND EQUIPMENT

Model No.	Cable Length'	Description	Price /Each
LE6500 SERIES			
XD053	30	16/3 SJE00W, Single Outlet	501.00
XD054	20	14/3 SJOW, Four Hospital Grade Outlets	890.00
XD055	10	14/3 SJOW, Four Hospital Grade Outlets	772.00
LE2300 SERIES			
XD056	20	CAT6 Cable, Retractable Data Reel	216.00
XD057	20	USB Cable, Retractable Data Reel	208.00

HEAVY-DUTY LED WORK LIGHTS & CORD REELS

- Virtually indestructible with a polycarbonate lens and rubber handle
- 50000 hour LED technology means never having to change a bulb again
- (XD047) LE1725LED has the same usable light output as a 13 W fluorescent work light
- (XD048) LE1625LED provides a value-priced lighting solution
- (XD047) LE1725LED also operates as a flashlight with a 1 W LED light on the end
- Standard with 25' of 18/2 SJTOW cord
- Also available on a 40' cord reel
- Certified for sale in Canada by an accredited certification body



LIND EQUIPMENT

Model No.	Description	Price /Each
XD047	8 W LED Work Light	177.00
XD048	4 W LED Work Light	131.00
XD049	40' Cord Reel w/8 W LED Work Light	285.00
XD050	40' Cord Reel w/4 W LED Work Light	223.00

WORK LIGHTS & CORD REELS



Positive latching mechanism allows the cord to be extended to any length required and automatically held in place. An adjustable ball stop provides easy height adjustment. Hardware included for either ceiling or wall mount.

INDUSTRIAL CORD REELS

- Provide secure wall or ceiling mounting
- A release tab on the mounting bracket quickly and easily converts the reel from stationary to portable use
- Large, comfortable carrying handle
- The non-metallic composite housing ensures a prolonged, corrosion-free service life
- Certified for sale in Canada by an accredited certification body



Incandescent Work Light



DB978



Fluorescent Work Light

Model No.	Cable Length'	Cable Type	Termination	Outlet Rating	Price /Each
DB978	40	12/3 SJTW	Triple Outlet	15 A, Breaker Protected	266.00
DB979	50	14/3 SJTW	Triple Outlet	13 A, Breaker Protected	266.00
DB980	50	14/3 SJTW	Incandescent Light	13 A, Breaker Protected	279.00
DB981	50	16/3 SJTW	26 W Fluorescent Light	7 A	323.00

INCANDESCENT WORK LIGHT REELS

- Incandescent work light is rated for a 75 W bulb
- Includes switch and circuit breaker protected outlet
- Grounded metal guard with reflector protects the bulb
- Certified for sale in Canada by an accredited certification body

Model No.	Cable Length'	Outlet Description	Rating	Price /Each
XA640	20	18/3 SVT Cord	7 A	62.00
XA155	30	16/3 SJT Cord	10 A	125.00
XA921	50	18/3 SVT Cord	7 A	120.00
XB122		Replacement Bulb		2.63



XA155

INDUSTRIAL 15A CORD REELS

- Four 5-20R grounded outlets providing a full 15 A of power
- Power "ON" light indicator
- 20' of 12/3 SJTOW oil resistant and cold weather flexible cable
- Strong steel housing and epoxy finish enable the reel to be used in most industrial environments
- 15 A Circuit breaker protection against power overloads, which have the potential to cause electrical fires
- Hardware for ceiling or wall mounting included
- Certified for sale in Canada by an accredited certification body



Model No. XD052
Price /Each \$179.00

EXTENSION REELS

- Triple outlet extension reel accommodates three tools
- Circuit breaker protects against power overloads, which can cause electrical fires
- Certified for sale in Canada by an accredited certification body

Model No.	Cable Length'	Outlet Description	Rating	Price /Each
XA154	30	16/3 SJT Cord	10 A	121.00
XB281	30	14/3 SJT Cord	13 A	142.00



XA154

FLUORESCENT WORK LIGHT REELS

- 13 W compact fluorescent work light is cool running
- Includes switch, hanging hook and full-length reflector
- Shatter-proof polycarbonate shield allows tool-free lamp replacement
- Light output is 900 lumens
- Certified for sale in Canada by an accredited certification body



XA289

Model No.	Cable Length'	Description	Price /Each
XA289	40	18/2 SJT Cord	127.00
XA412	30	16/3 SJT Cord, 9 A Outlet in Light	138.00

CORD REELS

Spring retractable cord reels are available in 3 styles. Standard female receptacle, LED and fluorescent lamp. Engineered for industrial use, these units are also compact, can be installed on walls, ceilings or under a tool bench.

Dimensions: 12 5/8" L x 9 3/8" W x 13 1/4" H.

All units feature 125 V SJTOW cord.

Certified for sale in Canada by an accredited certification body



XA172



TNB516



Model No.	Max. Amps	Cable Length'	Gauge	Wt. lbs.	Price /Each
LED					
TNB516	13	50	16/3	27	659.00
FLUORESCENT					
XA174	0.3	50	16/2	26	599.00
SINGLE OUTLET					
XA172	13	50	16/3	26	539.00

TECHNICAL INFORMATION

EXTENSION CORD RATING DESIGNATIONS

Indented on each Prime® cord is a letter designation that defines the type and approved use of the cord. You will see that each Prime® extension cord carries one of the following designations.

PRIME® OUTDOOR VINYL EXTENSION CORDS

SJTW (UL) Water Resistant or c(UL) SJTW FT2
STW (UL) Water Resistant or c(UL) STW FT2

PRIME® ALL-WEATHER TPE-RUBBER EXTENSION CORDS

SJEOW (UL) Water Resistant or c(UL) SJEOW FT2
SEOW (UL) Water Resistant or c(UL) SEOW FT2

PRIME® RUBBER EXTENSION CORDS

SJ (UL) Water Resistant or c(UL) SJ FT2
SJO (UL) Water Resistant or c(UL) SJO FT2
SJOW (UL) Water Resistant or c(UL) SJOW FT2
SJTOW (UL) Water Resistant or c(UL) SJTOW FT2
SO (UL) Water Resistant or c(UL) SO FT2
SOO (UL) Water Resistant or c(UL) SOO FT2
SOOW (UL) Water Resistant or c(UL) SOOW FT2
STOW (UL) Water Resistant or c(UL) STOW FT2

- S -** The "S" at the beginning of all designations states that the cord is a "Hard Service" flexible cord for general use.
- P -** Parallel construction, usually uninsulated and used in products such as household extension cords, air conditioner cords and low voltage landscape cable.
- J -** The "J" after the "S" defines the jacket of the cord as being the standard 300 V insulation type currently used on most extension cords. The absence of the "J" defines the cord jacket as an extra hard service 600 V insulation type defined by Prime® as our "Double Jacket" cord because the outer cord jacket is roughly twice the thickness of the "J" jacket that is normally used in outdoor extension cords.
- V -** Vacuum wire, softer and more flexible than standard "SJT", usually found on retractable cord reels and vacuum cleaner power supply and cords because it holds up to constant winding and unwinding but still maintains its shape.
- T or E -** This letter defines the material the insulation and jacket are made from. "T" defines the insulating material as PVC (vinyl) thermoplastic. The letter "E" defines the insulation and jacket material as TPE-thermoplastic elastomer rubber.
- O -** The letter "O" defines the cord as being "Oil Resistant". This was especially designed because most rubber type cords would break down and lose insulating performance when exposed to oil or grease.
- W -** This letter designates that the cord has been rated for outdoor use. As part of this rating, the different insulation and jacket compounds must meet the following use temperature ranges. UL sets a use temperature range of the "T" PVC vinyl material at -31°F to +140°F (-35°C to +60°C). Prime® has formulated the PVC vinyl compound in our products to exceed this nominal range by approximately 5°F. UL sets a use temperature range of the "E" TPE-rubber material at -58°F to +221°F (-50°C to +105°C). Prime® has also exceeded this range by approximately 12°F.
- (UL) -** This defines the cord as being "Underwriters Laboratories" listed. UL allows the use of the logo in parenthesis rather than a complete circle on round product, like a cord.
- Water Resistant -** Most of Prime®'s outdoor cords are now made with water resistant material. Standard vinyl and TPE-rubber cords have a tendency to absorb water if left lying in a puddle on the job site. When water comes in contact with the copper wire, it starts to corrode. If the water remains in the cord, it could build up until a shock path is created. When water gets in a cord, its life is shortened.
- CSA -** Defines the product as meeting "Canadian Standards Association" requirements. The CSA logo is usually not abbreviated.
- C(UL) & C CSA US -** Since the NAFTA agreement with Canada, UL and the Canadian Standards Association, CSA, have worked together to allow CSA to list products for the USA and for UL to list products for use in Canada. The c(UL) designation says the product was tested and certified by UL to Canadian Standards and the c CSA us mark signifies that CSA tested the product and certifies it to the UL Standards.
- FT2 -** This letter group defines the product as being flame retardant. If a standard vinyl or TPE-rubber cord catches on fire, the flame can quickly burn the entire length of the cord. The Prime® jacket insulation material will prevent the spread of combustion along the cord. The cord will extinguish the flame within 30 seconds of the heat source being removed.
- CL2 -** Or "Class 2" is a UL rating for wire that can be used for in-wall construction. Usually applies to communication cable or speaker wire.
- SRDT -** Is heavy-duty wire made specifically for use with higher amperage equipment such as ranges, dryers and mobile home power hook-up cords. Not very flexible.
- HPN -** Is high-heat parallel neoprene wire made specifically for use with clothes irons, portable heaters and other such applications where high temperatures of the appliance could affect the power cord's performance.



Cord Gauge vs Amperage

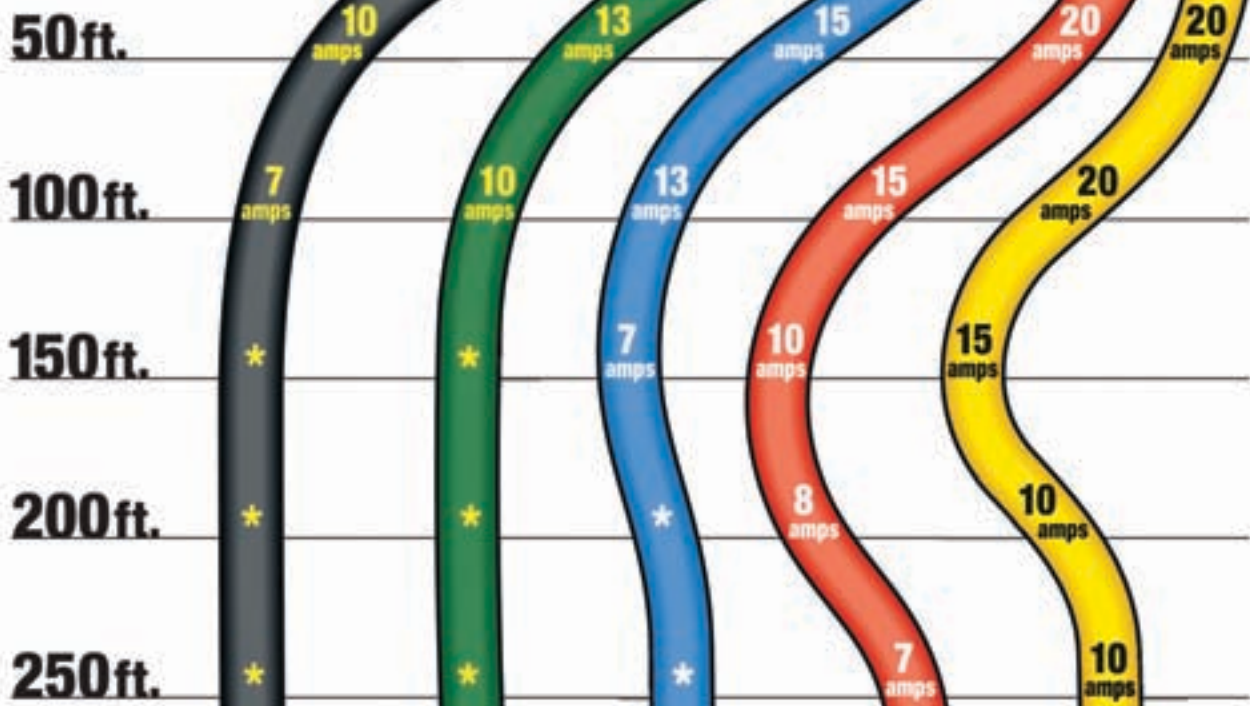

PRIME

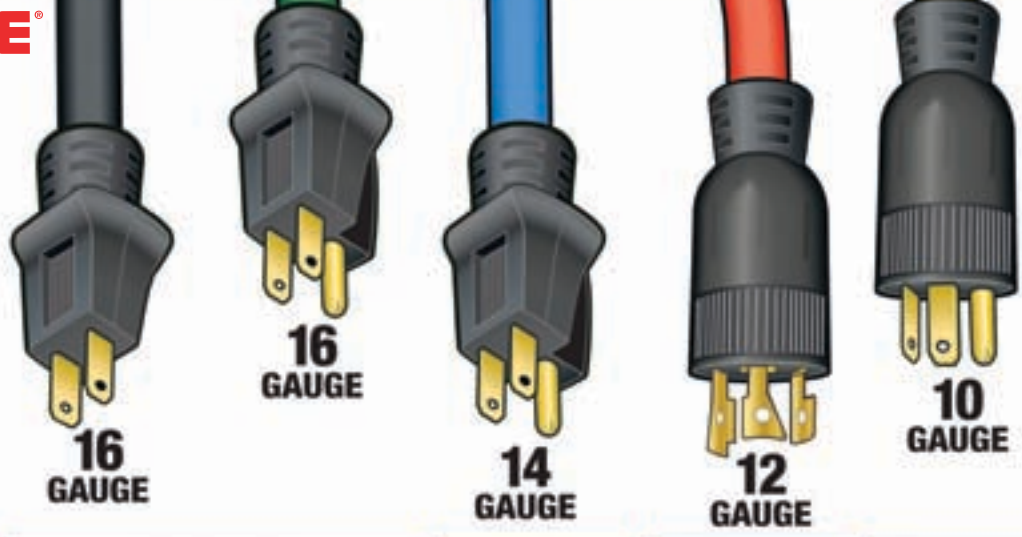

TYPICAL USAGE GUIDE	MEDIUM DUTY		HEAVY DUTY	EXTRA HEAVY DUTY	ULTRA HEAVY DUTY
	Fans	Lawnmowers	Drills	Circular Saws	Generators
Small Appliances	Hedge Trimmers	Belt Sanders	Chain Saws	Recipro Saws	
Stereos	Space Heaters	Routers	Worm Drives	Rotary Hammers	
Household Tools	Jig Saws	Table Saws	Grinders	Compressors	

*Not recommended for use at this length

OUTDOOR VINYL EXTENSION CORDS

- Designed for industrial and contractor use
- Vinyl jacket protects against rough use, chemicals, and moisture and provides added flexibility
- Molded-on and bonded plugs and connectors resist breaking

3-CONDUCTOR SJTW, 300 V GROUNDING

Model No.	Length'	AWG	Amps	Watts	Colour	Price /Each
HEAVY-DUTY						
XC482	25	14/3	15	1875	Orange	22.50
XC483	50	14/3	15	1875	Orange	42.80
XC484	100	14/3	13	1625	Orange	83.95
EXTRA HEAVY-DUTY						
XC485	25	12/3	15	1875	Yellow	36.35
XC486	50	12/3	15	1875	Yellow	64.25
XC487	100	12/3	15	1875	Yellow	115.00



aurora tools®



XC485

OUTDOOR VINYL TRIPLE TAP EXTENSION CORDS

- Designed for industrial and contractor use
- Vinyl jacket protects against rough use, chemicals, and moisture
- Vinyl jacket provides added flexibility
- Molded-on and bonded plugs and connectors resist breaking

3-CONDUCTOR SJTW, 300 V GROUNDING

Model No.	Length'	AWG	Amps	Watts	Colour	Price /Each
HEAVY-DUTY						
XC488	25	14/3	15	1875	Red	31.70
XC489	50	14/3	15	1875	Red	54.25
XC490	100	14/3	13	1625	Red	98.65
EXTRA HEAVY-DUTY						
XC491	25	12/3	15	1875	Red	42.40
XC492	50	12/3	15	1625	Red	77.55
XC493	100	12/3	15	1625	Red	122.00



aurora tools®



XC491

OUTDOOR VINYL TRIPLE TAP EXTENSION CORDS

- Designed for use by contractors and industrial personnel
- Jacket protects against rough use, chemicals, moisture, ozone and gives added flexibility at below freezing temperatures
- Molded-on and bonded vinyl plugs and connectors resist breaking or pulling off cord
- Nickel-coated brass blades resist corrosion
- **XA719, XA720, XA721** are No Overload® circuit breaker extension cords

3-CONDUCTOR SJTW, 300 V GROUNDING

Model No.	Length'	AWG	Amps	Watts	Colour	Price /Each
HEAVY-DUTY						
XA719	25	14/3	15	1875	Red	36.40
XA720	50	14/3	15	1875	Red	62.30
XA721	100	14/3	13	1625	Red	113.00
EXTRA HEAVY-DUTY						
XA722	25	12/3	15	1875	Yellow	48.70
XA723	50	12/3	15	1875	Yellow	89.00
XA724	100	12/3	15	1875	Yellow	139.00



PRIME®



NEMA 5-15P

XA719



NEMA 5-15R

GLACIER FLEX™ 3-OUTLET ENGINE BLOCK HEATER CORDS

- 3 conductors, SJTW -50°C, 300 V grounding
- Water-resistant
- Flame retardant
- Ultra flexible
- Nickel-coated brass blades resist corrosion
- Temperature range from -50°F to +140°F (-50°C up to +60°C)
- Primelight® indicator light flashes blue and red when power is on

Model No.	Length'	AWG	Amps	Watts	Price /Each
XC730	15	16/3	13	1625	20.00



PRIME®



XC730

EXTENSION CORDS & OUTLETS

ALL WEATHER TPE-RUBBER EXTENSION CORDS WITH LIGHT INDICATOR

- Designed for industrial and contractor use
- All-weather jacket provides ultra flexibility and superior performance in extreme climate conditions at temperatures from -50°C to 105°C
- Provides outstanding resistance against rough use, sunlight, chemicals and moisture
- Water-resistant and flame retardant
- Lighted connectors allow you to see when the power is in use
- Molded-on and bonded plugs and connectors resist breaking



aurora tools

3-CONDUCTOR SJEOW, 300 V GROUNDING

Model No.	Length'	AWG	Amps	Watts	Colour	Price /Each
HEAVY-DUTY						
XC500	25	14/3	15	1875	Blue/Orange	26.75
XC501	50	14/3	15	1875	Blue/Orange	49.50
XC502	100	14/3	15	1625	Blue/Orange	93.25
EXTRA HEAVY-DUTY						
XC503	25	12/3	15	1875	Blue/Orange	36.95
XC504	50	12/3	15	1875	Blue/Orange	77.95
XC505	100	12/3	15	1875	Blue/Orange	139.00



XC500

ARCTIC BLUE™ ALL-WEATHER TPE-RUBBER LIGHTED END EXTENSION CORDS W/PRIMELOK® & PRIMELIGHT®

- Arctic Blue™ cords are designed for use by contractors and industrial personnel, providing an all weather cordset made for outstanding performance in extreme climate conditions at temperatures from -58°F to 221°F (-50°C to 105°C)
- One-third lighter than standard rubber cords
- Provides superior resistance to sunlight, ozone, cracking, oils and chemicals and are outstanding in resistance to abuse, rough handling and wear
- Flame retardant and water resistant
- Distinctive orange stripe extruded into the cord
- PrimeLok® keeps power tool connections from coming loose
- Primelight® indicator light allows you to see there is power to the cord



3-CONDUCTOR SJEOW, 300 V GROUNDING

Model No.	Length'	AWG	Amps	Watts	Colour	Price /Each
HEAVY-DUTY						
XB894	25	14/3	15	1875	Blue/Orange	34.00
XB895	50	14/3	15	1875	Blue/Orange	64.80
XB896	100	14/3	13	1625	Blue/Orange	111.00
EXTRA HEAVY-DUTY						
XB897	25	12/3	15	1875	Blue/Orange	45.00
XB898	50	12/3	15	1875	Blue/Orange	78.30
XB899	100	12/3	15	1875	Blue/Orange	153.00



XB895



ARCTIC BLUE™ ALL-WEATHER TRIPLE TAP TPE-RUBBER LIGHTED END EXTENSION CORDS W/PRIMELIGHT®

- Arctic Blue™ cords are designed for use by contractors and industrial personnel
- All weather cordset made for outstanding performance in extreme climate conditions at temperatures from -58°F to 221°F (-50°C to 105°C)
- Superior resistance to ozone, oils, chemicals and rough handling
- Flame retardant and water resistant
- Primelight® indicator light allows you to see there is power to the cord



3-CONDUCTOR SJEOW, 300 V GROUNDING

Model No.	Length'	AWG	AMPS	Watts	Colour	Price /Each
EXTRA HEAVY-DUTY						
XB902	25	12/3	15	1875	Blue/Orange	54.70
XB903	50	12/3	15	1875	Blue/Orange	106.00
XB904	100	12/3	15	1875	Blue/Orange	173.00



XB904



NEMA 5-15R



NEMA 5-15P

EXTENSION CORDS & OUTLETS

OUTDOOR VINYL EXTENSION CORDS WITH LIGHT INDICATOR

- Designed for industrial and contractor use
- Vinyl jacket protects against rough use, chemicals, and moisture
- Ultra flexible cord
- Lighted connectors allow you to see when the power is in use
- Molded-on and bonded plugs and connectors resist breaking
- Water-resistant and flame retardant



aurora tools®

3-CONDUCTOR SJTOW, 300 V GROUNDING, OIL RESISTANT

Model No.	Length'	AWG	Amps	Watts	Colour	Price /Each
EXTRA HEAVY-DUTY						
XC494	25	12/3	15	1875	Yellow	38.20
XC495	50	12/3	15	1875	Yellow	67.50
XC496	100	12/3	15	1875	Yellow	120.00



XC494

OUTDOOR TRIPLE TAP VINYL EXTENSION CORDS WITH LIGHT INDICATOR

- Same great features as outdoor single tap vinyl extension cords but with a lighted triple tap connector



aurora tools®

3-CONDUCTOR SJTOW, 300 V GROUNDING, OIL RESISTANT

Model No.	Length'	AWG	Amps	Watts	Colour	Price /Each
EXTRA HEAVY-DUTY						
XC497	25	12/3	15	1875	Yellow	44.50
XC498	50	12/3	15	1875	Yellow	81.45
XC499	100	12/3	15	1875	Yellow	128.00



XC497

INDOOR/OUTDOOR STANDARD-DUTY EXTENSION CORDS

- Designed for light industrial, contractor, and home use
- Durable SJTW jacket protects against ultraviolet rays, chemicals and moisture
- Extremely flexible jacket
- Molded-on and bonded plugs and connectors resist breaking



aurora tools®

3-CONDUCTOR SJTOW, 125 V GROUNDING

Model No.	Length'	AWG	Amps	Watts	Colour	Price /Each
XC630	10	16/3	13	1625	Orange	10.35
XC631	15	16/3	13	1625	Orange	14.25
XC632	25	16/3	13	1625	Orange	21.10
XC633	50	16/3	13	1625	Orange	38.40



XC630

7000WR PRO-REEL™ CORD CARRIERS

- Stores up to 100' of 12/3 extension cord
- Made of heavy-duty, high impact plastic for durability
- Mounts on wall (bracket and template included)

Model No. XA761
Price/Each \$60.80

LIND EQUIPMENT



WIND-UP EXTENSION CORD

- 4 Grounded outlets
 - Built-in resettable circuit breaker
 - Length: 25'
 - Gauge (AWG): 16/3
 - Amperage: 10 A
 - Wattage: 1250 W
- Model No. XE671
Price/Each \$37.20

aurora tools®



CORD CADDIES

- 25' cord reel with four outlets
 - Built-in resettable circuit breaker
 - 16/3 SJT cable
 - 12 A, 1500 W
- Model No. XC615
Price/Each \$35.80

cUL US
PRIME



EXTENSION CORDS & OUTLETS

NEON FLEX® HIGH VISIBILITY NEON COLOUR OUTDOOR EXTENSION CORDS W/PRIMELIGHT®

- Combine all the features of a standard vinyl outdoor extension cord with ultra-high-visibility neon colours
- Brighter than other coloured cords and also extremely shiny
- Flame retardant and water-resistant
- Nickel coated brass blades resist corrosion
- Primelight® connector allows you to see when the power is on
- Ultra flexible, contractor tough



NEMA 5-15P



NEMA 5-15R

XB891

3-CONDUCTOR SJTW, 300 V GROUNDING

Model No.	Length'	AWG	Amps	Watts	Colour	Price /Each
EXTRA HEAVY-DUTY						
XB890	50	12/3	15	1875	Neon Green	75.80
XB891	100	12/3	15	1875	Neon Green	133.00
XB892	50	12/3	15	1875	Neon Pink	75.80
XB893	100	12/3	15	1875	Neon Pink	133.00

THE PRO-TEC-TOR™ CIRCUIT BREAKER EXTENSION CORD

- The only extension cord with a circuit breaker that can be reset right at the outlet end
- Protects cordset from equipment overload, which can cause electrical fires
- Safety yellow SJTW cord
- Certified for sale in Canada by an accredited certification body



XA055

Model No.	Description	Wire Ga./Cond.	Voltage	Cord Length'	Rating Amps	Price /Each
14-GAUGE EXTENSION CORDS						
XB983	Triple Outlet	14/3	125	6	15	22.20
XA054	Triple Outlet	14/3	125	25	15	42.60
XA059	Triple Outlet	14/3	125	50	15	70.90
12-GAUGE EXTENSION CORDS						
XC057	Triple Outlet	12/3	125	25	15	60.00
XA055	Triple Outlet	12/3	125	50	15	101.00
XA056	Triple Outlet	12/3	125	100	15	168.00

HEAVY-DUTY NEOPRENE EXTENSION CORDS

- Designed to provide longer life in the most demanding environments, such as industrial, mining, and construction sites
- Made of heavy-duty rubber suitable for indoor and outdoor applications requiring flexibility and mechanical toughness
- Exceptional resistance to oil, moisture, ozone, sunlight, chemicals, cuts, cracking, and abrasions
- Stays flexible, even at -40°F (-40°C) and resists heated objects and oils up to 194°F (90°C)
- 600 V SOOW cable has oil-resistant double-thick outer jacket and oil-resistant inner insulation
- Includes rugged nylon plug and connector rated for 125 V 15 A (NEMA 5-15)
- Certified for sale in Canada by an accredited certification body



XA254

Model No.	Length'	Gauge	Cord Rating	Price /Each
XA071	25	16/3	13 A	80.90
XA260	50	16/3	13 A	116.00
XA255	100	16/3	10 A	182.00
XA253	25	14/3	15 A	106.00
XA254	50	14/3	15 A	164.00
XA252	100	14/3	15 A	272.00
XC996	25	12/3	15 A	116.00
XC997	50	12/3	15 A	182.00
XC998	100	12/3	15 A	314.00

GFCI's are complex devices that save lives and protect equipment every day in tough work environments. Whether it is due to water or damaged equipment and cords, ground faults can occur quickly and, if not resolved immediately, can result in severe injury or electrocution.

A GFCI, by standards definition, must trip the circuit if a ground fault occurs with a maximum of 6 mA of current loss to ground. If a ground fault is sensed, a Class A GFCI will trip in less than 25 ms, protecting you and your workers.

Rule 76-016 of the Canadian Electrical Code (2006 and 2009) states that, on demolition and construction projects, all 15 A and 20 A temporary receptacles (e.g. extension cords) MUST be protected with a Class A type GFCI.

Many provinces also require that ALL receptacles used to power portable tools and equipment MUST be protected with a Class A GFCI.

GFCI PROTECTED TRI-CORDS

- Features three NEMA 5-15R receptacles at the end of a heavy-duty molded T-head
- Perfect for outdoor, rugged, construction type environments
- 2' 12/3 SJTW cord
- 120 V/15 A
- Available with right angle plug (XA468) or with in-line plug (XC519)
- Certified for sale in Canada by an accredited certification body

Model No. XA468
Price/Each \$56.60
Model No. XC519
Price/Each \$77.80



LIND EQUIPMENT

PLUG & CORD SETS

- Ideal for use with any equipment used in or around wet areas
- Rainproof rated with booted test and reset buttons
- 9" 14/3 SJTW cord
- NEMA 5-15 P & R, 120 V/15 A
- Certified for sale in Canada by an accredited certification body

Model No. XA463
Price/Each \$47.20



LIND EQUIPMENT

GFCI QUAD OUTLET BOXES

- Four GFCI protected NEMA 5-15R outlets enclosed in an impact resistant polymer case with spring-loaded covers
- 15 A "fast breaker" is built into the box for convenient reset should an overload condition occur
- 6' 12/3 SJTW cord
- 120 V/15 A
- Certified for sale in Canada by an accredited certification body

Model No. XA467
Price/Each \$173.00

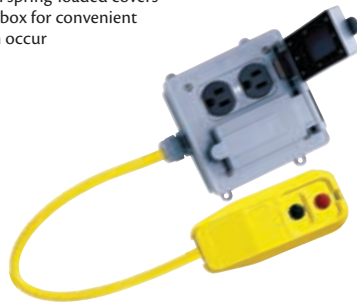

LIND EQUIPMENT

IN-LINE GFCI CORD SETS

- Excellent for use with high pressure washers, power drain snakes, submersible pumps and any equipment used in or around wet areas
 - Rainproof rated with booted test and reset buttons
 - Standard 14" length (other lengths available upon request)
 - Certified for sale in Canada by an accredited certification body
- NOTE: XA466 includes 120 V/20 A straight blade ends



LIND EQUIPMENT

Model No.	Cord Type	NEMA P & R	Volts /Amps	Price /Each
XE722	12/3 SJTW	5-15	120 V/15 A	94.60
XA466	12/3 SJTW	5-20	120 V/20 A	158.00

SHOCKSAFE® INLINE GFCI TRIPLE-TAP ADAPTER

- Triple lighted tap
 - 3' 12/3 SJTW cord
 - 125 V/15A
- Model No. XC614
Price/Each \$48.30



PRIME ETL

GFCI & CIRCUIT TESTER

- Increasing the test impulse setting until the GFI trips, will determine the leakage-current trip point for the GFCI under test
- Meter produces adjustable mA test impulses at 4-second intervals
- Tests and indicates condition of GFCI's and circuits
- Easy-to-read indicator lights display wiring errors
- Adjustable test impulses:
 - 0 mA and 3 mA trip - unit too sensitive
 - 5 mA and 7 mA trip - unit acceptable
 - 10 mA and 30 mA trip - unit not safe

Model No. HC704
Price/Each \$325.00



GREENLEE

EXTENSION CORDS & OUTLETS

GFCI OUTLET ADAPTORS W/SURGE PROTECTION

- Small size (less than 2" W x 3" H) makes them ideal for the toolbox
- **XB069** includes booted test and reset buttons
- NEMA 5-15 P & R, 120 V/15 A
- Certified for sale in Canada by an accredited certification body

Model No. XB069 Yellow
Price/Each \$40.40



USER ATTACHABLE GFCI PLUGS

- Replaces any standard NEMA 5-15 P plug on cords between 12-18 AWG (SJT)
- For use where the GFCI is needed as a permanent part of the tool or appliance
- Rainproof rated with booted test and reset buttons
- NEMA 5-15 P, 120 V/15 A
- Certified for sale in Canada by an accredited certification body

Model No. XA462
Price/Each \$64.30



USER ATTACHABLE INLINE GFCI

- Easily wires onto cord between 12-18 AWG (SJT)
- Can be placed at any location on the cord set
- Rated for up to 20 amps to allow for use on equipment that operates on either a 15 A or 20 A circuit
- For use where the GFCI is needed as a permanent part of the tool or appliance
- Rainproof rated with booted test and reset buttons
- 120 V/20 A
- Certified for sale in Canada by an accredited certification body

Model No. XB070
Price/Each \$89.70



FLOORTRAKS®

- Ideal for cables that run over the floor where portable cords and cables cannot be concealed
- Flexible, non metallic cover
- Protects, organizes and reduces trip hazards
- Available in three different sizes
- Handles cables up to 1.25" (31.8 mm) in diameter

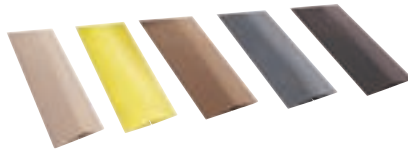

DIMENSIONS OF FLOORTRAKS®

FloorTrak®	2	3	4
Width	2.75"	3.00"	3.25"
Height	0.53"	0.75"	1.10"
Ctr. Hole	0.60" x 0.31"	0.75" x 0.50"	1.21" x 0.75"



Model No.					Description	Length'	Price /Each
Black	Brown	Beige	Grey	Yellow			
XA042	XA038	XA005	XA001	XA039	FloorTrak® 2	10	39.50
XA009	XA041	XA040	XA006	XA245	FloorTrak® 3	5	29.60
XA043	-	-	-	XA046	FloorTrak® 4	5	36.60

MULTIMEDIA SURGE PROTECTORS

- Surge protector for small electronics
 - Comes with 2 USB 3.1 ports for direct charging
 - Has a docking shelf to hold electronic devices
 - Joules: 900
 - No. of Outlets: 3
 - Voltage: 125 V
 - Max. Amps: 15 A
- Model No. XE851**
Mfg.No PB802112
Price/Each \$16.50



ZENITH®
Safety Products

GLOVES
TRAFFIC CONTROL
SPILL CONTROL
EYEWEAR

SAFETY

1150 JOULES SURGE PROTECTORS

- Provide extra power outlets for home electronics in the workshop, the kitchen, or the office
- Features high energy absorbing joule ratings and EMI/RFI filters
- Clear Power® auto shutoff safety device shuts power off after absorbing a major spike
- Lighted On/Off circuit breaker switch
- 6 outlet black metal housing prevents damage to the casing
- 14/3 SJT snug plug low profile power cord
- 15 A, 1875 W
- \$200 000 connected equipment warranty
- Length: 15'

Model No. XC042
Mfg.No PB802135
Price/Each \$30.80



EXTENSION CORDS & OUTLETS

750 JOULES 6-OUTLET SURGE PROTECTORS

- Provides extra power for home electronics
- Features high energy joule rating
- Clear Power® auto shut-off safeguard shuts power off after absorbing a major spike
- \$100 000 connected equipment warranty

Model No. XC299
Price/Each \$9.95



400 JOULES 6-OUTLET SURGE PROTECTOR

- 125 V / 15 A, 1875 W
- Clear Power® auto shut-off safeguard shuts power off after a major spike
- \$100 000 connected equipment warranty

Model No. XC616
Price/Each \$9.56



ROTATING SURGE TAPS

- 6 protected grounded rotating outlets
- 2160 Joules, 15 A / 125 V
- Clear Power® auto shut-off safeguard shuts power off after a major spike
- \$300 000 connected equipment warranty

Model No. XC621
Price/Each \$29.60



SURGE SUPPRESSOR

- Ideal for multiple electronic devices
- Lighted on/off switch with built-in circuit breaker
- Protects against damage caused by power spikes
- No. of Outlets: 6
- Cord Length: 3'
- Rated Joules: 200
- Max. Amps: 15 A
- Wattage: 1875 W

Model No. XE670
Price/Each \$8.75

aurora tools



4', 12-OUTLET POWER BARS

- Provides extra power for home electronics
- 6', 14/3 extension cord
- Lighted on/off circuit breaker
- Mounting hardware included
- 5-year warranty

Model No. XC291
Price/Each \$37.60



PRIME



AIR CONDITIONER & MAJOR APPLIANCES EXTENSION CORDS

- Molded-on bonded vinyl plugs and connectors will not break off or pull
- Cord resists cracking and breaking
- 3-conductor SPT-3
- 15 A, 1875 W
- 14/3 SPT cable

PRIME

Model No.	Length'	Price /Each
XC156	3	4.44
XC157	6	7.49

For air conditioners, please see page 1500



WORKSHOP STRIPS

- Additional grounding outlets from a single outlet source
- 8 outlets: 5 standard, 3 wide space
- 6', 14/3 cord
- 15 A, 1875 W
- Metal housing prevents damage to the casing
- Lighted on/off circuit breaker switch for overload protection
- Indoor use only
- 5-year warranty

PRIME

Model No.	Description	Price /Each
XC040	8 outlet metal shop box	27.20



GENERATOR "Y" CORDS

- 20 A T-blade plug to 20 A T-slot connectors
- Enables user to draw full 20 A load (5 more amps than a standard U-Ground connector)
- 25' 12/3 STOW wire
- 20 A / 125 V / 2500 W
- Primelight® power indicator light indicates when power is ON
- Double-jacketed, super abrasion resistant
- Oil and water resistant
- Flame retardant
- Ultra-flexible in extreme temperatures from -58°F up to +221°F (-50°C up to +105°C)
- For use with virtually all generators
- Used for lighting, small air conditioners, air compressors, water pumps, power tools and equipment with 1 HP rating

Model No. XD001
Price/Each \$77.80

PRIME



EXTENSION CORDS & OUTLETS

ISOBAR® PREMIUM SURGE SUPPRESSORS

- Virtually indestructible all-metal housing for added protection and longer life
- Isolated filter banks eliminate cross interference
- "Cascade Circuitry" provides increasing levels of noise rejection
- 3 Diagnostic LEDs to provide advance warning of potential power problems
- Meets stringent UL1449 (2nd edition), UL 1283, UL 1363 and cUL standards with UL's highest performance 330 V
- Instantaneous (0 nanoseconds) surge response time
- Ultimate Lifetime Insurance covers the Isobar® and connected equipment against surge damage for life



OD752

Model No.	AC Receptacles	Cord Length'	Isolated Filter Banks	Energy Surge Rating Joules	Surge Current Rating Amps	Price /Each
OD751	4	6	2	3330	85 000	94.50
OD752	6	6	3	2850	92 000	107.00
OD753	8	12	4	3840	92 000	123.00

PROTECT-IT SURGE SUPPRESSORS

- Multi-Stage suppression circuitry safeguards equipment against lightning and surge damage
- EMI/RFI Noise rejection reduces computer lock-ups, data errors, audio, static and video interference
- Protected LED indicator
- Meets stringent UL1449 (2nd edition) and cUL standards with UL's highest performance (330 V)
- Ultimate Lifetime Insurance covers connected equipment against surge damage for life
- Colour: Computer Grey
- Lifetime Warranty

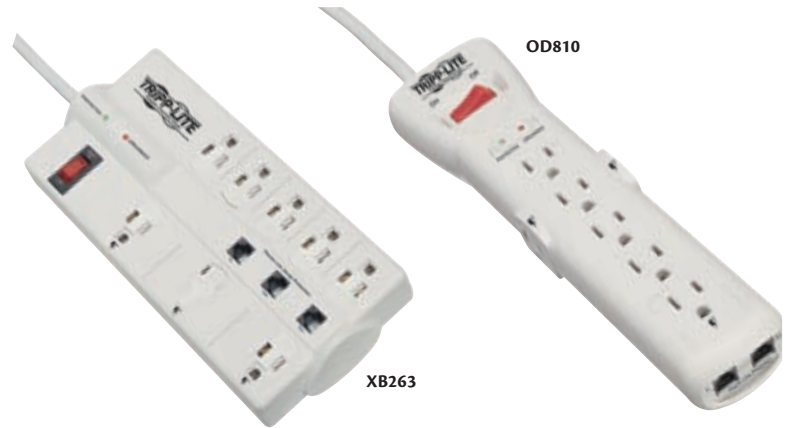

XB263

OD810

Model No.	Outlets	Cord Length'	Fax/Modem/Phone (RJ11)	Joule Rating	Grounded LED Indicator	Multiple Transformer Outlets	Ultimate Lifetime Insurance	Price /Each
XB262	6	4	1 in/1 out	720	No	No	\$20 000	19.90
OD809	7	6	1 in/1 out	1080	No	Yes	\$50 000	36.50
OD755	7	7	No	2160	Yes	Yes	\$75 000	34.40
OD810	7	7	1 in/1 out	2470	Yes	Yes	\$75 000	43.00
XB263	8	8	1 in/2 out	2160	Yes	Yes	\$150 000	55.90

STANDBY UPS SYSTEMS

These systems provide complete protection against all types of power problems (brownouts, blackouts, surges and line noise). Up to 450 VA of battery backup gives you time to save your open files and safely shut down your computer in the event of a prolonged brownout or a blackout. In addition, BC Personal® UPS stops damaging lightning and surges. \$25 000 Ultimate Lifetime Insurance coverage guarantees your equipment will stay safe from surge damage for life!



OD759

OD757



Model No.	Description	Price /Each
OD757	Personal® 350 VA UPS, 6 outlets	97.80
OD758	Personal® 550 VA UPS, low battery light, self-test, 8 outlets	132.00
OD759	Internet Office, 900 VA UPS, 2-line fax/phone protection, 8 outlets	262.00

BOOSTER CABLES

- Clamp design fits on both top-post and side-post batteries
- Surge suppressor on 2, 4, and 6 gauge cables protect a vehicles computer system from power surges during boosting
- Cable remains flexible in temperatures as low as -40°C
- Tangle-free



Model No.	Wire Gauge	Amps	Length'	Price /Each
XE494	8	150	10	21.85
XE495	6	400	16	46.40
XE496	4	400	20	53.65
XE497	2	400	20	120.00

CANADIAN WIRE CONNECTOR KITS

450 PIECES

- A variety of connectors to fit a large range of wire sizes
- Great for servicing technicians
- Convenient and durable carrying case
- Reusable packaging
- Made in Canada
- UL Listed and CSA Certified
- Kit Components:
 - 20 x WingTwist® Wire Connector - Blue 14-6 AWG (WT 54 - Rated 600V)
 - 20 x Canadian Wire Twist™ - Red 18-14 AWG (C6 - Rated 600V)
 - 85 x Can-Twist™ 22-8 AWG (007 - Rated 600V)
 - 50 x Canadian Wire Twist™ - Yellow 18-10 AWG (C4 - Rated 600V)
 - 50 x Can-Twist Extreme™ 22-12 AWG (007XT - Rated 600V)
 - 100 x WireTwist® Wire Connector - Blue 22-14 AWG (WT2 - Rated 300V)
 - 50 x WireTwist™ Wire Connector - Gray 22-14 AWG (WT1 - Rated 300V)
 - 75 x Canadian Wire Twist™ - Orange 18-14 AWG (C3 - Rated 600V)



Model No.	Mfg. No.	Connection Type	Wire Range (AWG)	Voltage	Colour	Price /Each
XE850	30-2088	Twist	26-6	Mixed	Mixed	57.00

CAN-TWIST™ WIRE CONNECTORS

- Exceptional wire-range capacity - handles wire combinations from 22 to 8 AWG solid and/or stranded wires
- Easily removed for repeat usage
- Flexible walls show when wires are firmly connected
- Spring threads are heat-set, making them more reliable
- Extended skirt length provides over-strip protection
- Smaller size makes it easier to work in tight spaces
- Wide mouth and square springs deliver quicker pick-up
- Swept wings provide added gripping power
- Easier to twist: only a few turns are necessary to achieve torque
- Wire Combination Range: 600V #22 thru 8 AWG, Min.3 #22 Max.3 #10
- CSA 22.2#188 Certified



Model No.	Mfg. No.	Quantity /Pkg.	Price /Pkg.
XC085	30-107J	175	17.20
XC086	30-307J	475	46.00

CABLE TRACERS

- All components are fully fuse protected and intrinsically safe
- Model R2000 Receiver has two detectors in its tip which are tuned to pick up the electromagnetic signals or electrostatic signals
- LEDs and sensitivity settings indicate the relative signal strength
- Model S2600 Load Signal Generator, when connected to an energized line, will draw a rapidly fluctuating current pulse from the source, causing the power line to emit an electromagnetic signal
- Model T2200 Transmitter injects a signal into an unenergized conductor R2000
- Model A2201 Inductive Clamp when clamped around the energized line and plugged into the T2200 will induce a signal onto the downstream (load) side
- Includes: Receiver, load signal generator, transmitter, clamp-on transmitter accessory, cordsets and adapter



Model No.	Mfg. No.	Description	Price/Each
HD909	AT-2004	Cable Tracing System	1995.00

YELLOW 77® WIRE PULLING LUBRICANT

- Wax-based formula provides superior lubricity
- Safe to use with most cable types except low-density polyethylene and semi-conducting jackets
- Clings to cable through long pulls
- Environmentally safe - non-toxic, non-flammable, non-corrosive
- Dries to a thin, non-conductive film that won't clog conduit



Model No.	Description	Price /Each
AB488	1 qt. Squeeze Bottle	13.10
AB489	1 gal. Tub	26.50

VOLTALERT™ VOLTAGE DETECTOR

- Small, rugged and reliable, the VoltAlert™ is designed for ease of use – if the tip glows red and the unit beeps when touching a terminal strip, outlet, or cord, there is voltage
- IA156 continually tests its battery and its circuit integrity with a periodic double flash visual indication using Fluke Voltbeat™ technology
- Voltage detection of 90 to 1000 VAC, as well as a 24 to 90 VAC control circuit model
- Cat. IV – 1000 V overvoltage category rating for added user protection
- **Covered by a two-year warranty**



IA216



Model No.	Mfg. No.	Description	Price /Each
IA156	1-AC-A1-II	ACV Detector, 90-1000 V	41.00
IA216	1LAC-A-II	Low Voltage Detector, 20-90 VAC	41.00

ELECTRICAL DEVICES & ACCESSORIES

ELECTRICAL TAPE

- Vinyl plastic
- Excellent recovery, molds snugly to any surface
- Ideal for electrical splicing and insulation; protection against solvents and corrosion
- For use between -7°C and 80°C
- Thickness: 7 mils
- CSA approved



Priced per Roll

Model No.	Colour	Dimensions	Price /Each
PA665	Black	3/4" x 60' (18 mm x 18 m)	1.17
XC545	Red	3/4" x 66' (18 mm x 20.1 m)	1.63
XC546	Green	3/4" x 66' (18 mm x 20.1 m)	1.63
XC547	Blue	3/4" x 66' (18 mm x 20.1 m)	1.63
XC548	White	3/4" x 66' (18 mm x 20.1 m)	1.63
XC549	Yellow	3/4" x 66' (18 mm x 20.1 m)	1.63

TEMFLEX™ ELECTRICAL TAPE

- General purpose, flexible vinyl tape designed for indoor or short term use and bundling
- Temperature rating: 176°F/80°C
- Colour: Black
- Thickness: 7 mil
- UL and CSA approved



Priced per Roll

Model No.	Dimensions	Roll /Case	Price /Each
PC695	3/4" x 60' (19 mm x 18.3 m)	100	0.93

SCOTCH® SUPER 88 VINYL TAPE

- All weather, premium grade vinyl tape for primary insulation up to 600 V or protective jacketing for low/medium voltage cable splices
- Aggressive adhesive and elastic backing ensures easy conformation to irregular surfaces for moisture tight electrical and mechanical protection
- Will perform in a continuous temperature environment up to 220°F (105°C)
- Conformable for cold weather applications: 0°F (-18°C)
- Thickness: 7 mil • Colour: Black
- UL and CSA approved



Priced per Roll

Model No.	Dimensions	Roll /Case	Price /Each
PC694	3/4" x 66' (19 mm x 20.1 m)	100	7.80

SCOTCH® 130C LINERLESS RUBBER SPLICING TAPE

- Highly conformable, linerless self-bonding ethylene propylene rubber (EPR) tape for insulating all solid dielectric cables up to 69 kV
- Excellent thermal dissipation of splice heat
- Meets industry specifications, excellent physical and electrical properties
- Immediate moisture sealing and void-free buildups
- Rated up to 194°F (90°C) continuous operation and up to 266°F (130°C) short-term overload service
- Having no liner makes jobs easier and saves time
- Thickness: 30 mils



Priced per Roll

Model No.	Dimensions	Rolls/Case	Price/Each
XC323	1" x 30'	24	21.20

SCOTCH® SUPER 33+ VINYL TAPE

- All weather, premium grade vinyl tape for primary insulation up to 600 V or protective jacketing for low/medium voltage cable splices and repairs
- Aggressive adhesive and elastic backing ensures easy conformation to irregular surfaces for moisture tight electrical and mechanical protection
- Will perform in a continuous temperature environment up to 220°F (105°C)
- Conformable for cold weather applications: 0°F (-18°C)
- Thickness: 7 mil
- Colour: Black
- UL and CSA approved



Priced per Roll

Model No.	Dimensions	Roll /Case	Price /Each
PC693	3/4" x 66' (19 mm x 20.1 m)	100	6.98

SCOTCH® 35 COLOUR CODING VINYL TAPE

- Premium grade vinyl electrical colour-coding tape for phase and job identification and safety
- Heavy-duty, premium grade
- Temperature rating: 220°F/105°C
- Thickness: 7 mil
- UL and CSA approved



Priced per Roll

Model No.	Colour	Dimensions	Rolls /Case	Price /Each
PC696	Blue	1/2" x 20'	100	2.25
PC720	Green	1/2" x 20'	100	2.25
PC721	Red	1/2" x 20'	100	2.25
PC722	White	1/2" x 20'	100	2.25
PC723	Yellow	1/2" x 20'	100	1.80
XC309	Orange	1/2" x 20'	100	2.25
PE118	Blue	3/4" x 66'	100	7.08
PE120	Green	3/4" x 66'	100	7.08
XC312	Red	3/4" x 66'	100	7.08
PE119	White	3/4" x 66'	100	7.08
XC314	Yellow	3/4" x 66'	100	7.08
XC315	Orange	3/4" x 66'	100	7.08

SCOTCH® 27 GLASS CLOTH ELECTRICAL TAPE

- Ideal for electrical maintenance applications
- Woven glass cloth tape with a rubber thermosetting pressure-sensitive adhesive
- Edge-tear resistant, conformable, abrasion resistant
- For use as a coil cover, anchor, banding and core, layer and crossover insulation, and for heat-stable insulation for furnace and oven controls, motor leads, and switches
- Thickness: 7 mils
- UL recognized 130°C/266°F

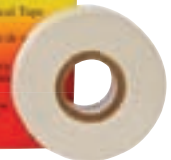

Priced per Roll

Model No.	Dimensions	Rolls/Case	Price/Each
XC322	3/4" x 66' (19 mm x 20.1 m)	50	23.60

COLOURFLEX™ TAPE

- General purpose colour coding vinyl tape
- Thickness: 7 mils



Priced per Roll

Model No.	Colour	Dimensions	Roll /Case	Price /Each
XC316	Blue	3/4" x 60'	100	1.13
XC317	Green	3/4" x 60'	100	1.13
XC318	Red	3/4" x 60'	100	1.13
XC319	White	3/4" x 60'	100	1.13
XC320	Yellow	3/4" x 60'	100	1.13
XC321	Orange	3/4" x 60'	100	1.13



3M

ADF Filters.....	1126
Adhesive Bandages.....	741
Ambient Air Pump Respirators.....	466, 481, 1127
Anti-Skid Tape.....	873
Backing Pads.....	921, 925, 935
Box Sealing Tape.....	1410-1411, 1429
Bristle Brushes.....	921, 1271
Bristle Discs.....	921
Burnishing Pads.....	362
Butterfly Wound Closures.....	742
Compresses.....	746
Conspicuity Tape.....	850
Contact Cement.....	1029
Cut & Polish Wheels.....	938
Cut-Off Wheels.....	912, 916
Deburring Wheels.....	936, 938, 1271
Degreasers, Heavy-Duty.....	319, 1005, 1036
Disc Holder Pads.....	923, 925, 927, 935-936, 938
Display Hangers, Merchandise.....	1435
Disposable Respirators.....	448-449
Document Laminators.....	1574
Double Sided Tape.....	1416
Duct Tape.....	1415
Dust Mask Dispensers.....	453
Ear Plugs	
Dispensers.....	427
Disposable.....	425
Fabric Bandages.....	741
Faceshields.....	412
Filament Tape.....	1412
Filter Plates.....	1126
Finishing Wheels.....	938
Flap Brushes.....	937
Flap Discs.....	918
Flap Wheels.....	919, 937
Full Face Respirators.....	455
Glasses	
Reading.....	399
Safety.....	399-401
Glue, Sticks.....	1418
Glue Guns.....	1418
Goggles, Safety.....	406
Grinding Wheels, Type 27.....	915
Half Mask Respirators.....	454-455
Hand Pad Holders.....	933-934, 938
Hand Scrubbers.....	302
Helmets, Welding.....	1126-1127
Magnifier Plates.....	1126
Masking Tape.....	1414
Packing List Envelopes.....	1449
Pads, Cleaning.....	292, 362
PAPR Respirators.....	466, 471-473, 475, 477, 479, 481, 1127
Penetrants, 5-Way.....	1013
Plastic Bandages.....	741
Polyethylene Foam Tape.....	1416
Positive Pressure Respirators.....	466, 477
Power-Lock Discs.....	925, 935
Resin Fibre Discs.....	923, 925
Respirators	
Cartridges.....	456, 466, 472-473, 475, 477
Filters.....	456-457, 475
Fit Test Kits.....	465
Headgear.....	473, 479, 1127
Sanding Sponges.....	933
Sandpaper.....	930, 932
Scouring Pads.....	302, 320, 362
Self-Stick Bandages.....	742, 746
Sheathing Tape.....	1437
Sound Level Meters, Integral Probe.....	440, 1480
Spray Adhesives.....	1036, 1418
Spray Lubricants.....	1008
Stethoscopes.....	756
Stick-On Discs.....	927
Stripping Pads.....	362
Supplied Air Respirators.....	466, 479
Surface Conditioning Belts.....	937
Surface Conditioning Discs.....	934-936, 938
Surface Conditioning Pads.....	302, 933

Surface Conditioning Rolls.....	930, 933-934
Tape	
Electrical.....	1417, 1544
First Aid.....	744
Office.....	1580
Tape Dispensers	
Filament Tape.....	1411
Gummed Tape.....	1411
Two-Way Tape.....	1416
Vinyl Tape.....	1416
Wipes.....	465

ACCENT HOME

Small Parts Cabinets.....	33
---------------------------	----

ACCUFORM SIGNS

Accident Prevention Tags.....	786-788, 790
Admittance Signs.....	803-810, 813
Blank Tags.....	791-792
Cable Ties.....	793
Chemical Hazard Signs.....	804, 808
Confined Space Signs.....	804, 808
CSA Standard Signs.....	814-817
Direction Signs.....	811
Ear Protection Signs.....	806, 809
Electrical Hazard Signs.....	804-805, 808
Exit Signs.....	807, 810
Eye Protection Signs.....	806, 809
Fall Protection, Signs.....	806
Fire Protection, Signs.....	653, 807, 810, 812, 817, 822
First Aid, Signs.....	727, 805, 809, 812
Floor Signs.....	813
GHS	
Information Centres.....	848
Information Charts.....	847
Safety Labels.....	844-845
Wallet Card.....	844
Hazardous Materials Signs.....	808
ISO Safety Labels.....	818-819, 845
Machinery & Operations Signs.....	804-805, 809
Maintenance Signs.....	808-809, 813
MSDS	
Binders.....	849
Information Centers.....	848-849
No Smoking Signs.....	806-808, 810
Parking Signs.....	810
Pipe Markers.....	833-841
Protective Wear Signs.....	806, 809
Safety Signs.....	727, 806, 809, 849
Scoreboard Signs.....	822-823
SDS	
Binders.....	849
Information Centre.....	848-849
Poster.....	847
Self-Adhesive Letters.....	800
Self-Adhesive Numbers.....	800
Shipping & Receiving Signs.....	813
Tags, Lockout.....	786-788, 790
Traffic Signs.....	210, 807, 810, 812, 820-821, 851
Washroom Sign.....	813
Wheel Locks.....	782
WHMIS	
Information Charts.....	847
Labels.....	846
Pictograms.....	845-846
Posters.....	847

AIGNER INDEX

Aisle Signs.....	12, 48
Label Holders.....	5, 12, 48, 72-73
Label Makers, Accessories.....	5, 12
Magnetic Tags.....	12

AIR MASTER

Ceiling Fans.....	1498
Drum Fans.....	1497, 1502

Exhaust Fans.....	1501
Pedestal Fans.....	1497-1499
Wall Mounted Fans.....	1497-1498

AIRFLOW

Integral Probe Anemometers.....	1486
---------------------------------	------

AKRO-MILS

Small Parts Cabinets.....	34
Stacking Bins.....	5

ALB PLUS

Cabinets, Storage.....	97-98, 1561, 1563
Dollies, Steel Deck.....	97, 103
Lockers, Steel.....	104

ALDON

Rail Chocks.....	210
Wheel Chocks.....	210

ALEMITE

Grease Guns.....	997
Grease Pumps.....	999
Pipe Fittings, Lubrication.....	999, 1001

ALGOOD

Casters.....	229-230
Wheels.....	232-233

ALLEGRO INDUSTRIES

Axial Blowers.....	488-489
Centrifugal Blowers.....	489
Fan Guards.....	489
Guard Rails.....	489
Knee Pads, Leather.....	1133
Manhole Lid Lifters.....	489
Manhole Shields.....	489
Portable Blowers.....	488
Tent Heaters.....	489
Work Tents.....	489

ALLEN INDUSTRIAL HAND TOOLS

Hex Keys.....	1346-1347
---------------	-----------

ALLIANCE PLASTICS

Poly Tubing.....	1430
------------------	------

ALLPAX

Rubber Cutting Knives.....	1371
----------------------------	------

ALL-VAC INDUSTRIES

Magnetic Lifters.....	196
Vacuum Cups.....	196-197

ALNOR

Balometers.....	1488
Temperature Probes.....	1488

ALTE-REGO

Bags, Laundry.....	303
Construction, Vapor Barriers.....	1437
Garbage Bags.....	278, 281-282, 383, 761
Gaylord Liners.....	280
Liners, Container.....	280
Pallet Covers.....	1423
Poly Tubing.....	1437

BRAND INDEX

Seat Cover, Automotive.....280
Tire Bags.....280

AMANO CINCINNATI

Time Clocks.....1575

AMERICAN WATER BROOM

Water Brooms.....377

AMPCO

Ball Pein Hammers, Non-Sparking.....1380
Cabinet Tip Screwdrivers.....1383
Cross-Point Screwdrivers.....1383, 1386
Crowbars, Non-Sparking.....1380
Curved Blade Knives.....1382, 1386
Curved Claw Hammers.....1380
Diagonal Cutters.....1383
Flat Tip Screwdrivers.....1383, 1386
Hammers, Non-Sparking.....1380, 1386
Hand Chisels.....1381
Hand Scrapers, Non-Sparking.....1382, 1386
Hex Keys, Non-Sparking.....1383
Linoleum Knives.....1382
Maintenance Brushes.....1383, 1386
Mallets.....1380
Non-Sparking Tool Kits.....1386
Non-Sparking Tools
Pliers.....1383, 1386
Wedge.....1381
Wrenches.....1384-1386
Picks.....1381
Pinch Bars.....1380
Pry Bars
Crate Openers.....1380, 1386
Nail Pullers.....1380
Non-Sparking.....1380
Putty Knives
Flexible.....1382
Stiff.....1382, 1386
Round Point Shovels.....1381
Scoop Shovels.....1381
Scrapers, Drywall.....1382
Screwdrivers, Sets.....1383
Sledge Hammers, Non-Sparking.....1380
Sockets, Non-Sparking.....1385
Spatulas, Non-Sparking.....1382
Square Point Shovels.....1381
Straight Blade Knives.....1382, 1386
Utility Knives.....1382

AMPROBE

Cable Tracers.....1468, 1543

ANSELL

Chemical Resistant Gloves.....583, 586-589
Coated Gloves.....562-577, 580, 591
Cut Resistant Gloves.....575-578, 580
Disposable Gloves.....594, 598-599
Gloves, Holders.....593
Winter Lined Gloves.....571, 593, 626

ANTHONY STEEL MFG.

Cabinets, Storage.....97
Gas Cylinder, Lockouts.....106
Lockers, Steel.....106

APEX

Bit Holders.....1343
Cross-Point Bits.....1345
Hex Bits.....1344
Hex Square Drive Bits.....1343
Nutsetters.....1343

Posidriv® Bits.....1345
Slotted Bits.....1344-1345
Square Recess Bits.....1344-1345
Torque Bits.....1343
Torx® Bits.....1343-1344
Tri-Wing Bits.....1344

ARMSTRONG TOOLS

Adjustable Wrenches.....1330
Aligning Punches.....1369
Angle Wrenches.....1335
Ball Pein Hammers, Fiberglass Handle.....1365
Box Wrenches
15 Degree Offset.....1336
25 Degree Offset.....1336
45 Degree Offset.....1336
Geared.....1331
Brass Hammers.....1365
Cape Chisels.....1368
C-Clamps.....1289
Center Punches.....1368
Chain Nose Pliers.....1348
Chisel Holders.....1367
Cold Chisels.....1367-1368
Combination Wrenches.....1331
Sets.....1337
Convertible Pliers.....1353
Copper Hammers.....1365
Dead Blow Hammers.....1363
Diagonal Cutters.....1348
Drift Punches.....1369
Flare Nut Wrenches.....1335-1336
Flex Head Wrenches.....1335
Gear Wrenches, Sets.....1337
Hex Bit Sockets.....1315-1316
Impact Sockets.....1323-1325, 1327
Lineman's Pliers.....1348
Mallets.....1363
Needle Nose Pliers.....1349
Nut Drivers
Hollow Shaft.....1342
Sets.....1342
Open End Wrenches.....1335
Pin Punches.....1369
Pinch Bars.....1367
Power Sockets.....1323, 1327
Pry Bars
Rolling Head.....1367
with Handle.....1367
Pump Wrenches.....1335
Ratchets
1 1/2" Drive.....1324
1" Drive.....1324
1/2" Drive.....1315, 1321
1/4" Drive.....1324
3/4" Drive.....1322
3/8" Drive.....1316, 1319
Retaining Ring Pliers.....1353
Rolling Head Bars.....1367
Slip Joint Pliers.....1348
Socket Accessories.....1314-1316, 1319, 1321-1324, 1327
Socket Sets, Standard.....1314-1315
Sockets, Standard.....1314-1316, 1319, 1321-1322
Soft Face Hammers.....1363
Spanner Wrenches.....1330
Starting Punches.....1370
Striking Face Wrenches.....1331
Structural Wrenches.....1330
Tongue & Groove Pliers.....1348
Torque Meters.....1329
Torque Multipliers.....1328
Torque Wrenches.....1328

ARROW

Carton Staplers.....1446-1447
Nail Guns, Electric.....1446
Nails, for Nail Guns.....1446

Staples

Carton Staplers.....1446-1447
Pneumatic Stapler.....1447

ATLAS GRAHAM

Angled Brooms.....290
Boot Covers.....289, 889
Buckets.....305
Corn Brooms.....289-290
Dusters, Janitorial.....302
Dustpans.....290
Extension Poles.....287-288, 293, 297-298, 302
Floor Scrapers.....298
Frames, Dust Mop.....293, 302
Litter Scoops.....290
Maintenance Brushes.....26, 300-301
Microfiber Cloths.....293
Mops
Dust.....293, 295
Wet.....292-293, 295, 304-306
Pads, Cleaning.....292
Pot Brushes.....26, 301
Push Brooms.....287-290, 301
Scouring Pads.....292
Scrub Brushes.....26, 291, 300
Shelf Carts.....168
Shoe Covers.....289, 889
Squeegees.....297-299, 301
Switch Brooms.....290
Toilet Bowl Brushes.....349
Vehicle Brushes.....292
Whitewash Brushes.....292
Window Brushes.....292

ATLAS WELDING ACCESSORIES

Chipping Hammers, Welding.....1087-1088

ATRIX

Vacuums
Accessories.....361
Wet / Dry.....361

AURORA TOOLS

Adjustable Wrenches.....1309-1312, 1332
Angle Grinders, Air.....1204
Ball Pein Hammers, Wood Handle.....1309-1310, 1312, 1362, 1365
Bench Vises.....1293
Blades, Packaging Knife.....1440
Bolt Cutters.....1360
Booster Cables.....1542
Broadcast Spreaders.....364, 370
Cabinet Tip Screwdrivers.....1309-1312, 1338
Cable Ties.....1452
Calipers, Digital.....1275, 1309-1310
Carton Staplers.....1446
Caulking Guns.....1024
C-Clamps.....1288
Center Punches.....1309-1310, 1312, 1368, 1370
Chippers, Air.....1088, 1207
Claw Hammers.....1362
Club Hammers.....369, 1365
Cold Chisels.....1309-1310, 1312, 1367, 1370
Combination Wrenches.....1332
Sets.....1309-1310, 1312, 1332
Control Valves.....1000
Cord Reels, Extension Cords.....1537
Cross-Point Screwdrivers.....1309-1312, 1338
Curved Claw Hammers.....1309-1312, 1364
Cut-Off Tools, Air.....1204
Dead Blow Hammers.....1309-1312, 1362-1363
Diagonal Cutters.....1309-1312, 1348, 1353
Die Grinders, Air.....1204
Drain Spades.....366
Drift Punches.....1309-1310, 1369-1370
Drills, Air.....1205

BRAND INDEX

Eyewash Stations	
Faucet Mounted.....	720
Pedestal Mounted.....	717
Self Contained.....	722-723
Sink Mounted.....	720
Wall Mounted.....	716, 720
Lockers, Plastic	109
Privacy Shower Curtain	727
Shower Testers	726
Soap Dispensers	326
Thermostatic Mixing Valves	721

BRADY

Aisle Marking Tape	869
Ball Valve Lockouts	783
Barricade Tape	868
Disposable Dust Masks	453
Ear Plugs, Dispensers	431
Exit Signs	811
Flagging Tape	869
Glasses, Safety	407
Gloves, Dispensers	600
Glow in the Dark Tape	811
Label Makers	
Accessories.....	825, 827-828
Portable.....	824-825, 827
Ribbons.....	824-828, 830
Table Top Versions.....	828
Tapes.....	825-826, 828-830
Lockouts	
Kits.....	777
Stations.....	772
Vinyl Tape	829
WHMIS	
Labels.....	846
Wallet Cards.....	846

BRK ELECTRONICS

Fire Protection, Fire Alarm Protectors	655
---	-----

BROTHER

Label Makers	
Portable.....	1572-1573
Ribbons.....	1573
Table Top Versions.....	1572-1573
Tapes.....	1572-1573

BUCAN

Heaters	
Drum.....	237
Pail.....	237

BULMAN

Paper Cutters	1432
----------------------	------

BULWARK

Arc Flash Clothing	
Coveralls.....	554-555
Jackets.....	555
Overalls.....	555
Pants.....	554
Shirts.....	554
Coveralls, Work	554
Parkas	555

BW TECHNOLOGIES BY HONEYWELL

Docking Stations	482-483
Gas Detectors	
Calibration Gas.....	484
Sensor.....	484
Multi-Gas Detectors	482-484

Regulator, Calibration Gas	484
Single-Gas Detectors	482

C.H. HANSON

Barricade Tape	868
Beaded Chain	794
Blank Tags	793
Chain, Crowd Control	794
Flagging Tape	869
Hand Stamps	795-796
Ink Stencils	797
Key Rings	794
Locking Pliers	1352
Marking Flags	871
Numbered Tags	793
Paint Stencils	798
Seals	
Sealing Press.....	794
Security.....	794

C.R. DANIELS INC.

Hampers	303
Ironer Trucks	303
Linen Trucks	303

CALDWELL

Lifters, Drum	238
----------------------	-----

CAMFIL FARR

Air Filters	1506
--------------------	------

CAMPBELL

Clamps, Lifting	198
Clevis Grab Hooks	192
Hooks, Lifting	192

CANABLAST

Dust Collectors, Sandblasting	1056
Guns, Sandblasting	1057
Media, Sandblasting	1055
Media Recyclers, Sandblasting	1056
Portable Blasters, Sandblasting	1057
Suction Cabinets	1056-1057

CANADIAN MAILBOX COMPANY

Mailboxes	1576
------------------	------

CANARM

Smoke Ejectors	1501
-----------------------	------

CANON

Paper, Printer & Photocopier	1579
---	------

CAP CANADA DISTRIBUTION INC.

Absorbents	684
-------------------	-----

CARDINAL CORRUGATED CONTAINERS

Small Parts Bins, Fiberboard	11
-------------------------------------	----

CARGOLOC

Bungee Cords	1455
Cargo Nets	1455
Tie-Downs	1455-1456

CASCADES

Facial Tissue	344
Hand Towels	340-342, 344, 1583
Napkin Dispensers	343-344, 1583
Napkins, Cafeteria	343-344, 1583
Paper Towel Dispensers	340-342, 1583
Paper Towels	344
Toilet Paper	340, 345-346
Toilet Paper Dispensers	345, 347
Wipes	336, 384
Wipes Dispensers	336, 340

CAULK MASTER

Caulking Guns	1024
----------------------	------

CCI CANADA

Channelizers, Traffic Control	864
Cones	
Safety.....	308
Traffic Control.....	862
Delineators, Traffic Control	863-864
Flashing Lights	866

CENTENNIAL

Racks, Drum	245
--------------------	-----

CERTAINTY WIPES

Wipes Dispensers	334
-------------------------	-----

CHAPIN

Sprayers, Lawn & Garden	320, 371-372
------------------------------------	--------------

CHECKERS INDUSTRIAL PRODUCTS

Cable Protectors, Dock	217
Wheel Chocks	211

CHEMETALL

Non-Aqueous Developers	1144
Non-Chlorinated Degreasers	1144
Penetrants, Water Based	1144

CHEMOTEC

Dish Detergents	316
Floor Cleaners	310
Floor Finishes	311
Floor Sealers	311
Floor Stripper	311
Hand Cleaners, Lotion	326
Oven Cleaners	316
Stainless Steel Cleaners	316
Toilet Bowl Cleaners	314

CHICAGO PNEUMATIC

Angle Grinders, Air	1211, 1215
Automotive Stands	207
Belt Sanders, Air	1213
Bottle Jacks	206
Chippers, Air	1213
Die Grinders, Air	1212, 1215
Drills, Air	1209
Engravers, Air	1212
Garage Jacks	206
Hammers, Air	1213
Impact Wrenches, Air	1208, 1210, 1214
In-Line Drills, Air	1209
Mini Die Grinders, Air	1215
Orbital Sanders, Air	1211-1212
Ratchet Wrenches, Air	1210
Reciprocating Saws, Air	1214
Rotary Sanders, Air	1211

Scalers, Air.....	1214
Screwdrivers, Air.....	1209, 1211
Shears, Air.....	1214

CI CALSTONE INC.

Bench Scales.....	1433
Casters.....	1433
Packaging, Benches.....	1433
Paper Cutters.....	1427, 1432-1433
Shipping, Benches.....	1433

CIMCO

Combination Slip-Joint Pliers.....	1377
Hex Wrenches.....	1378
Insulated Cutters.....	1377
Snipe Nose Pliers.....	1377
Technicians' Tools.....	1378-1379

CIMCOOL

Tapping Compounds.....	1149
------------------------	------

CK WORLDWIDE INC

Air (Gas) Cooled Torches.....	1101, 1103-1104
Alumina Nozzles.....	1106
Back Caps, TIG Torch.....	1108
Collet Bodies, TIG Torch.....	1107-1109
Collets, TIG Torch.....	1107
Fuse Blocks, TIG Torch.....	1110
Gas Hoses, Welding.....	1110
Lava Nozzles.....	1105
Power Cable Adapters, TIG Torch.....	1109
Power Cables, TIG Torch.....	1110
TIG Welders.....	1113
Torch Kits, Welding.....	1109
Tungsten Electrode Grinders.....	1113-1114
Tungsten Electrodes.....	1114
Water Cooled Torches.....	1103-1104
Water Hoses, Welding.....	1110

CLARKSON OSBORN

Adjustable Reamers.....	985
Annular Cutters.....	972, 1193
Burs, Carbide.....	990-991, 1215
Chucking Reamers	
Cobalt.....	985
HSS.....	981-985
Circular Split Dies.....	978, 980
Dies, Die Stocks.....	977
Drill Bits	
Aircraft Extension.....	968, 972
Jobber.....	963-967
Spiral Flute.....	972
Straight Shank.....	971
Taper Length.....	969
Taper Shank.....	971
End Mills	
Carbide.....	988-989
HSCo.....	986-987
HSS.....	986
Weldon Shank.....	986
Hand Reamers.....	981
Hand Taps.....	974-975, 977, 988
Hexagonal Dies.....	978-979
Machine Taps.....	976
Pipe Taps.....	973
Prentice Drill Bits.....	969-970
Screw Extractors.....	989
Tap & Drill Sets.....	973
Tap Wrenches.....	977
Taper Pin Reamers.....	982
Tool Holders, Turning Tools.....	986

CLECO

Impact Wrenches, Air.....	1222
In-Line Drills, Air.....	1221
Screwdrivers, Air.....	1222

CLOROX

Wipes.....	318, 759
------------	----------

CM INDUSTRIES

Beam Clamps.....	199
Beam Trolleys.....	190
Hoists	
Air.....	191
Electric.....	191
Manual.....	190-191

COGAN

Guard Rails.....	84
------------------	----

COLSON

Casters.....	230-231
Floor Lock Brakes.....	231

CONTOUR

Burning Guides.....	1117
Pipe Contour Markers.....	1116-1117
Pipe Flange Aligners.....	1116
Pipefitting Levels.....	1116-1117

COOLWORKS

High Visibility Clothing, Pants.....	551
--------------------------------------	-----

COOPER INDUSTRIES INC

Plugs, Electrical.....	1084
Receptacles, Electrical.....	1084

CORDEX

Buckles	
Plastic.....	1421-1422
Poly.....	1422
Steel.....	1421
Seals, Steel.....	1421
Strapping	
Dispensers.....	1422
Machines & Tools.....	1419
Poly.....	1422

CORNER EDGE

Edge Protectors.....	48, 1423
----------------------	----------

CRAMER

Stepladders.....	135
------------------	-----

CRC CANADA

Air Tool Oil.....	1261
Automotive Cleaners, Diesel Conditioner.....	1015
Battery Cleaners.....	1015
Brake Cleaners.....	1015
Carburetor Cleaner.....	1015
Contact Cleaners.....	1006
Degreasers, Heavy-Duty.....	1002-1003, 1005
De-Icer.....	1015
Dry Lubricants, Graphite.....	1008
Food Grade Degreasers.....	1003
Freeze Spray.....	1006
Lubricants, General Purpose.....	1013
Paint, Rubber.....	1015
Parts Washers.....	995

Rust Converters.....	1014
Spray Lubricants.....	1008

CRESCENT

Adjustable Wrenches.....	1332
Pry Bars, Multi-Purpose.....	1366

CREWS

Faceshields.....	412
------------------	-----

CROSBY

Beam Clamps.....	199
Clamps, Lifting.....	198

CROWN-MEAKINS

Paint Supplies	
Brushes.....	1047-1049
Roller Covers.....	1049-1051
Rollers.....	1051
Sponging & Ragging.....	1050

DAINOLITE LTD

Desk Lamps.....	1524, 1582
Fluorescent Lamps / Light Bulbs.....	1524, 1582
Halogen Lamps / Light Bulbs.....	1524, 1582
Incandescent Lamps / Light Bulbs.....	1582
Magnifiers	
Illuminated.....	1524
Lenses.....	1524
Wall Clocks.....	1575

DAKOTA

Thickness Gauges.....	1479
-----------------------	------

DANBY

Refrigerators.....	1584
--------------------	------

DBI SALA

Anchorage Connectors.....	517
Beam Clamp Anchors.....	517
Carabiners.....	516
Davits.....	490
D-Bolt Anchors.....	516
D-Ring Harnesses.....	495
Fall Protection, Harnesses.....	141, 494-495
Friction Bolt Anchors.....	516
Hard Hat Lanyards.....	524
Positioning and Restraint Lanyards.....	508
Rescue Systems.....	491-492, 496, 518
Rope Grabs.....	517-518
Self-Retracting Lanyards.....	492, 512
Self-Retracting Life Lines.....	492, 512, 518
Shock Absorbing Lanyards.....	141, 507
Tool Lanyards.....	524
Vertical Life Lines.....	517
Winches, Personal.....	492

DEB STOKO

Hand Cleaners, Lotion.....	332
Hand Creams.....	331
Hand Sanitizers.....	333
Shampoo.....	325
Skin Conditioners.....	333
Soap Dispensers.....	331-332
Sunscreen.....	335
Wipes.....	334

DECADE

Back Supports.....	642
--------------------	-----

BRAND INDEX

DEFELSKO

Porosity Detectors.....	1478
Thickness Gauges.....	1478

DEFENDER

Task Lights.....	1529
------------------	------

DELMHORST INSTRUMENT CO.

Moisture Meters.....	1477
----------------------	------

DENTEC

Eyewash Stations	
Bottled.....	724
Water Preservatives.....	722
Foot Warmers.....	636
Hand Warmers.....	629

DE-STA-CO

Hold-Down Clamps.....	1291-1292
Latch Clamps.....	1291-1292
Straight Line Clamps.....	1292
Toggle Clamps.....	1291

DEWALT

Angle Drills, Electric.....	1184
Angle Grinders, Electric.....	1168-1171
Bandsaws, Wood Cutting.....	1178
Battery Chargers.....	1167
Bench Grinders.....	1270
Caulking Guns.....	1161
Chop Saws.....	1174
Circular Saws, Heavy-Duty.....	1177
Combo Kits.....	1164-1166
Compressors, Air.....	1262
Cordless Power Tool Batteries.....	1157-1158, 1160-1161, 1164, 1167
D Handle Drills.....	1183
Demolition Hammers.....	1187
Die Grinders, Electric.....	1172
Drills	
Drill / Drivers.....	1182
Drill / Drivers - Cordless.....	1157, 1161
Hammer Drill / Drivers.....	1158
Hammer Drills.....	1184-1185
Hand Powered Drills.....	1182-1183
Impact Wrenches	
Cordless.....	1160
Electric.....	1181
Jig Saws, Heavy-Duty.....	1178
Laser Levels.....	1283
Mitre Saws.....	1175-1176
Nail Guns, Cordless.....	1163
Palm Sanders.....	1180
Plumb Bobs.....	1283
Reciprocating Saws, Electric.....	1179
Rotary Hammers.....	1185-1186
Screw Guns.....	1187
Shears, Power.....	1173

DIMAR

Circular Saw Blades.....	1203
Combination Saw Blades.....	1203
Cut-Off Blades.....	1203
Forstner Bits.....	1200
Mitre Saw Blades.....	1203

DIVERSIFIED PLASTICS INC.

Column Protectors.....	86
Stepstools, Polyethylene.....	136

DORMER

Combined Drills & Countersinks.....	961
Countersinks.....	962
Drill Bits, Jobber.....	948, 952
Hand Taps.....	957-960
Pipe Taps.....	960

DOTCO

Angle Drills, Air.....	1222
Angle Grinders, Air.....	1222
Die Grinders, Air.....	1223
Drills, Air.....	1223
Engravers, Air.....	1223
Pencil Grinders, Air.....	1223

DREMEL

Dremel Tools.....	1192
-------------------	------

DUPONT PERSONAL PROTECTION

Aprons, General Protection.....	534
Boot Covers.....	534
Coveralls	
General Protection.....	535-537
Limited Use.....	537
Hoods, General Protection.....	534
Lab Coats, General Protection.....	534, 536
Pants, General Protection.....	534
Shirts, General Protection.....	534
Sleeves, Polypropylene.....	534

DURATRACK

Strip Curtain Doors.....	91, 93
--------------------------	--------

DURHAM MANUFACTURING

Cabinet Drawers.....	37
Literature Displays.....	1568
Mail Sorters.....	1566
Parts Storage Carts.....	42
Revolving Bins.....	29
Small Parts Cabinets.....	33, 37, 42-43, 45
Small Parts Cases.....	36
Threaded Rod Racks.....	45
Wire Spool Carts.....	167
Workbenches.....	125

DUSTBANE

Carpet Cleaners.....	317
Degreasers, Heavy-Duty.....	313
Dilution Dispenser.....	313
Disinfectants.....	313, 318, 759
Environmental Cleaners.....	317-318
Floor Cleaners.....	311
Floor Finishes.....	362
Floor Sealers.....	362
Floor Stripper.....	362
Glass Cleaners.....	315
Hand Cleaners, Lotion.....	315
Industrial Cleaners, Multi-Purpose.....	313-314
Machine Cleaners, Heavy-Duty.....	320
Solvent Free Degreasers.....	313
Sweeping Compounds.....	290
Vacuums, Wet / Dry.....	360

DWYER

Ball Valves.....	1231
Butterfly Valves.....	1231
Manometers.....	1488

DYKEM

Paint Markers.....	1442
Tamper Proof Torque Mark.....	1342

DYMO

Label Makers	
Portable.....	1574
Software.....	1574
Tapes.....	1574

DYNABRADE

Belt Sanders, Air.....	1216-1217, 1220-1221
Buffers, Air.....	1221
Die Grinders, Air.....	1220
Orbital Sanders, Air.....	1218-1219
Swivel Connectors.....	1219, 1250

DYNAFLUX QUALITY PRODUCTS

Aluminum Cleaners.....	1145
Anti-Spatter.....	1145
Galvanizing Compounds.....	1144
Layout Fluids.....	1145
Nozzle Gels, MIG Gun.....	1145
Pump Lubricants.....	1144
Tungsten Electrode Grinders.....	1114

DYNALINE

Funnels, Polyethylene.....	317, 994
----------------------------	----------

EAGLE MFG.

Column Protectors.....	86
Edge Protectors.....	86, 216

E-A-R

Ear Plugs	
Corded.....	426
Dispensers.....	427
Disposable.....	424-427
Reusable.....	428-429
Uncorded.....	426
Hearing Bands.....	430-431

ECHO

Sprayers, Lawn & Garden.....	371
------------------------------	-----

EDGE SAFETY EYEWEAR

Glasses	
Cases.....	407
Safety.....	402-403

EDSAL

Bookcases.....	1567
Cabinet Tables.....	124
Cabinets, Storage.....	98, 103, 1561
Computer Cabinets.....	1559-1560
Filing Cabinets, Lateral.....	1563
Service Writers.....	126
Shelving Units	
Chrome.....	56
Steel.....	55-56, 58
Shop Desks.....	126
Tool Storage	
Cabinets.....	103
Carts.....	124
Workbenches.....	120, 125

ELMER'S

Carpenters' Glue.....	1029
Construction Adhesives.....	1029
Contact Cement.....	1029
Pencil Sharpeners.....	1578
White Glue.....	1029
Wood Glue.....	1029

ELWOOD PACKAGING

Boxes, Mailers.....	1434
Cones, Pallet.....	48, 1423

ENERGIZER

Batteries	
1.5 Volt.....	1507
12 Volt.....	1507
3 Volt.....	1507
6 Volt.....	1507
9 Volt.....	1507
AA Cell.....	1507,
AAA Cell.....	1507,
C Cell.....	1507,
D Cell.....	1507,
Battery Chargers	1507
Flashlights	
AA Cell.....	1517, 1519
Mini.....	1519
Rechargeable.....	1519
Waterproof.....	1517
Headlights, Hard Hat	419
Lanterns, 6 V	1517

ENERVAC

Vacuums, Wet / Dry.....	360
-------------------------	-----

ENPAC

Absorbents	685
Berms, Spill Control	711-712
Containers, Spill Control	709-710
Covers, Drum	699
Dollies	
Drum.....	701-702
Gas Cylinder.....	1078
Drip Pans	681
Drum Equipment	
Carts.....	701
Racks.....	703
Spill Pallets.....	704-705, 710
Trays.....	681, 703, 711
Funnels, Spill Control	699
Gas Cylinder	
Brackets.....	1079
Racks.....	1079
Stands.....	1079
Leak Diverters	683
Pail Funnels	699
Pools, Spill Control	711
Salvage Drums	700-702
Stackers	703

ERB SAFETY

Bump Caps.....	415
Hard Hats.....	414-415

ERGODYNE

Anti-Vibration Gloves	607
Back Supports	641-642
Balaclavas	553
Coats, Winter	552
Ergonomic Products, Gloves	603
Folding Chairs	382
Glasses, Cord Retainers	408
Gloves, Holders	629
Hard Hat Lanyards	420, 522
Hard Hat Liners, Cooling	646
Hats, Cooling	645
Headbands, Cooling	645, 647
Headlights, Hard Hat	549
Heat Resistant Gloves	605
Hydration Backpack	647
Impact Gloves	605

Knee Pads	
Co-Polymer / Ester Tricot.....	639
Foam.....	640
Gel.....	639-640
Rubber.....	640
Kneeling Pads	639
Neck Shades, Cooling	647
Pants, Work	552
Tennis Elbow Braces	643
Tool Lanyards	522-523
Tool Storage	
Aprons.....	1391
Bags.....	1392
Holdes.....	1392
Pouches.....	523, 1390, 1392
Towels, Cooling	645-646
Undergarments	552
Undershirts	552
Vests, Cooling	646
Winter Lined Gloves	604-605
Winter Liners	553
Work Tents	382, 647
Wraps, Cooling	645, 647
Wrist Supports	643-644

ESSELTE

File Folders.....	1564, 1579
-------------------	------------

EX-CELL

Carts, Laundry.....	303
---------------------	-----

EXPO ENGINEERING

Heaters	
Drum.....	237
Pail.....	237

EXTREME TOOLS

Tool Storage	
Cabinets.....	1396-1400
Carts.....	125, 1397, 1400
Chests.....	1396-1399

FAIRVIEW FITTINGS

Propane Hoses, Welding	1068
Regulators, Welding	1068

FALCON SIGNAL HORNS

Signal Horns.....	444
-------------------	-----

FANTASTIK

Disinfectants.....	314
--------------------	-----

FEATHERLITE

Double Stepladders	129, 131
Extension Ladders	132-133
Multi-Purpose Ladders	131-132
Platform Ladders	127, 129-131, 135
Single Ladders	127, 132-133
Stepladders	127-128, 134
Work Platforms	135

FEDERAL SIGNAL CORPORATION

Flashing Lights	222-223
Horns	221
Megaphones	444

FELLOWES

Desk Organizers	1577
Filing Boxes	1564

FELTON BRUSHES

Cup Brushes	945
End Brushes	940, 942, 944
Paint Supplies, Brushes	1046
Scratch Brushes	946-947
Tube Brushes	945
Wheel Brushes	942-944

FIBRE-METAL BY HONEYWELL

Face Shields	410, 557
Hard Hats	417

FILL-RITE

Hand Pumps	258
Rotary Pumps	258

FIRST

Fall Protection Kits	507
-----------------------------------	-----

FIRST ALERT

Disposable Gloves	656
Smoke Alarms, Ionization	655

FIRST SAFETY CORPORATION

Carts, Welding	1078
Gas Cylinder	
Brackets.....	1079
Trucks.....	1078
Racks, Welding	1078

FLAMBEAU

Small Parts Cases	36
--------------------------------	----

FLANGE WIZARD TOOLS

Pocket Levels	1115
----------------------------	------

FREUD

Circular Saw Blades	1202-1203
----------------------------------	-----------

FROST

Ashtrays	284-285
Bathroom Mirrors	350
Bicycle Racks	379
Clothes Hooks	350
Floor Signs	308
Garbage Bags	348-349
Garbage Cans	267, 270, 349-350
Grab Bar	350
Hand Dryers	351
Hand Towels	343
Liners, Waste Container	270
Paper Towel Dispensers	342-343
Recycling Containers	278
Sanitary Napkin Dispensers	348
Sanitary Napkin Receptacles	348
Sanitary Napkins	348
Shelves, Washroom	350
Soap Dispensers	326
Tampons	348
Toilet Paper Dispensers	347
Toilet Seat Cover Dispensers	348
Toilet Seat Covers	348

FULLER

Anti-Vibration Hammers	1364
Ball Pein Hammers, Anti-Vibration	1365
Cabinet Tip Screwdrivers	1340
C-Clamps	1289
Claw Hammers	1364

BRAND INDEX

Cross-Point Screwdrivers.....	1340
Curved Claw Hammers.....	1364
End Cutters.....	1349
Flat Tip Screwdrivers.....	1340
Knives, Packaging.....	1441
Precision Screwdrivers.....	1341
Pry Bars	
Multi-Purpose.....	1366
Tack Pullers.....	1340
Scratch AWL Screwdrivers.....	1340
Screwdrivers, Sets.....	1340
Spring Clamps.....	1288
Square Screwdrivers.....	1340

FULTON

Hand Winches.....	195
Industrial Jacks.....	207
Marine Jacks.....	207

GANTS LAURENTIDE

Heat Resistant Gloves.....	624
----------------------------	-----

GARANT

Axes, All-Purpose.....	368
Carpenter Axes.....	368
Club Hammers.....	369, 1366
Crowbars, Pitch Point.....	368
Cultivators.....	368
Garden Hose Hangers.....	378
Garden Spades.....	366
Grain and Coal Scoops.....	366
Hedge Shears.....	369
Hoes.....	368
Lopping Shears.....	369
Picks.....	368
Pry Bars, Nail Pullers.....	1366
Rakes.....	367
Round Point Shovels.....	366
Scoops, Aluminum.....	366
Sidewalk Scrapers.....	368
Sledge Hammers, Double Faced.....	369, 1366
Sleigh Shovels.....	365
Snow Brushes.....	364
Snow Shovels.....	364-365
Spading Forks.....	367
Square Point Shovels.....	365-366
Tree Pruners.....	369
Tree Trimmers.....	369
Turf Edgers.....	368

GARDEX

Filing Cabinets	
Lateral.....	1562
Vertical.....	1562
Safes.....	1562

GASFLUX

Flux.....	1145
-----------	------

GEARWRENCH

Combination Wrenches.....	1333
Sets.....	1334
Cross-Point Screwdrivers.....	1341
Flat Tip Screwdrivers.....	1341
Flex Head Wrenches.....	1334
Gear Wrenches, Sets.....	1333-1334
Hooks & Picks.....	1307
Impact Sockets.....	1326
Pry Bars, Multi-Purpose.....	1366
Ratcheting Wrenches.....	1333-1334
Screwdrivers, Sets.....	1341
Torque Wrenches.....	1328
Torx® Screwdrivers.....	1341

GENERAL

Bevels.....	1280-1281
Center Punches.....	1370
Inspection Mirrors.....	883
Precision Screwdrivers.....	1341

GENSTAR TECHNOLOGIES

Flowmeters, Welding.....	1068
Gas Cylinder, Wrenches.....	1073
Gas Hoses, Welding.....	1075
Gas Torches.....	1064
Heating Tips.....	1072
Outfits, Welding.....	1063-1064
Pressure Gauges, Dry.....	1068
Regulators, Welding.....	1066-1067

GENTEC

Gauge Protectors, Welding.....	1067
Heating Tips.....	1072
Outfits, Welding.....	1063
Regulator/Flowmeters, Welding.....	1068
Regulators, Welding.....	1066-1067, 1069

GERBER

Multi-Purpose Hand Tools.....	1355
Pocket Knives.....	1355

GERMIPHENE

Disinfectants.....	318, 759
Wipes.....	318, 465, 759

GILMOUR

Guns, Garden Hose.....	376
------------------------	-----

GLADE

Air Fresheners.....	322
---------------------	-----

GLOBAL

Bookcases.....	1567
Ergonomic Products, Seating.....	1547-1548
Filing Cabinets, Vertical.....	1563
Folding Tables.....	382, 1557
Monitor Mounts.....	1558
Office Desks.....	1567
Office Seating.....	1549
Stacking Chairs.....	1555
Stacking Tables.....	1556-1557
Task Seating.....	1552
Work Tables.....	1556, 1561

GOJO

Cream Dispensers.....	331
Hand Cleaners	
Cream.....	331
Foam.....	325, 329
Gel.....	328
Liquid.....	331
Lotion.....	326-329
Hand Towels.....	334, 384
Shampoo.....	329
Skin Conditioners.....	333
Skin Creams.....	333
Soap Dispensers.....	325, 330, 333

GOODWRAPPERS

Stretch Wrap	
Banding Film.....	1425
Cast.....	1424
Clear.....	1425
Coloured.....	1424
Opaque.....	1424
Stretch Wrap Dispensers.....	1424-1425

GOSS

Cutting Tips.....	1070-1072
Heating Tips.....	1072
Propane Torches.....	1064
Regulators, Welding.....	1064
Soldering Tips.....	1064
Torch Kits, Welding.....	1064

GREE

Air Conditioners.....	1500
Humidifiers.....	1500

GREENLEE

Bar Racks.....	53
Circuit Testers.....	1539

GREIF

Drums, Polyethylene.....	234
--------------------------	-----

GUARDAIR

Guns, Air.....	1228-1229
Pneumatic Pipe Fittings.....	1228
Vacuums, Accessories.....	1225

GW METAL

Garbage Cans.....	272, 383
-------------------	----------

H.K. PORTER

Bolt Cutters.....	1360-1361
Cable Cutters, Industrial Grade.....	1085, 1361
Iron Shear Cutters.....	1361
Rebar Cutters.....	1361

HANG-A-LIGHT

H.I.D. Lamps / Light Bulbs.....	1530
Task Lights.....	1530

HANNAY REELS

Reels, Welding.....	1076
---------------------	------

HARPER TRUCKS INC.

Hand Trucks.....	151
------------------	-----

HAWS

Emergency Showers.....	718-719
Eyewash, Water Heater.....	721
Eyewash Stations	
Faucet Mounted.....	720
Pedestal Mounted.....	717
Self Contained.....	722-723
Sink Mounted.....	720
Wall Mounted.....	716
Water Preservatives.....	722-723
Thermostatic Mixing Valves.....	721

HELLY HANSEN

High Visibility Clothing	
Overalls.....	543
Rain Jackets.....	543
Suits, Rain.....	543

HERBERT WILLIAMS

Escape Ladders.....	656
Extinguishers, Fire.....	652
Hazardous Materials Cabinets.....	665

HEXARMOR

Cut Resistant Gloves.....	580-581
Sleeves, SuperFabric®.....	529

HIGHLAND

Message Pads.....	1579
-------------------	------

HI-LITER

Hi-Liters.....	1578
Permanent Markers.....	1578

HILL PUMPS

Pumps, Drum.....	258
------------------	-----

HILMAN ROLLERS

Machinery Rollers.....	204-205
------------------------	---------

HILROY

Message Pads.....	1579
-------------------	------

HLF DIVERSIFIED INC.

Salt.....	364
-----------	-----

HOME SAFEGUARD INDUSTRIES, INC

Smoke Alarm Testers.....	656
--------------------------	-----

HONEYWELL

Aprons.....	531
Ball Valve Lockouts.....	783
Circuit Breaker Lockouts.....	782
Disposable Dust Masks.....	453
Disposable Respirators.....	452-453
Electrical Plug Lockouts.....	782
Eyewash Stations	
Bottled.....	724
Self Contained.....	722
Solutions.....	722-724
Supplemental.....	725
Water Preservatives.....	723, 725
Half Mask Respirators.....	458, 461
High Visibility Clothing, Rain Suits.....	543
Hoods, Rain.....	543
Lockouts, Stations.....	776
PAPR Respirators.....	480
Respirators	
Cartridges.....	461
Filters.....	461
Fit Test Kits.....	465
SCBA Respirators.....	469
Sleeves	
Canvas.....	528
Kevlar®.....	529
PVC.....	528
Vinyl.....	528
Tags, Lockout.....	789

HORIZON

Ergonomic Products, Seating.....	1547-1549
Footrests.....	1549
Keyboard Trays.....	1558
Keyboard Wrist Rests.....	1558
Office Seating.....	1546, 1548, 1554
Stacking Chairs.....	1555
Task Seating.....	1546, 1552, 1554

HOWARD LEIGHT BY HONEYWELL

Ear Muffs	
Cap Mounted.....	433-435
Headband.....	433-435, 549
Neckband.....	434
Ear Plugs	
Corded.....	423
Dispensers.....	427
Disposable.....	423-424, 427
Reusable.....	428
Hearing Bands.....	430
Two-Way Radios.....	435

HUBBELL

Cable Protectors, Office.....	218, 1540
-------------------------------	-----------

HUDSON

Sprayers, Lawn & Garden.....	372-373
------------------------------	---------

IDEAL

Spray Lubricants.....	1012, 1543
Wire Connectors.....	1543

ILLINOIS

Folding Gates.....	82-83
Security, Gates.....	82-83

IMPACTO

Anti-Vibration Gloves.....	607
Elbow Protectors.....	643
Foot Guards, Plastic.....	637
Forearm Protectors.....	643
Impact Gloves.....	607, 644
Insoles.....	638
Knee Pads	
Foam / Hard Shell.....	640
Hard Shell.....	640
Tennis Elbow Braces.....	643
Toe Guards.....	637
Wrist Supports.....	643-644, 746

INCOM TOP TAPE & LABEL

Aisle Marking Tape.....	869-870
Anti-Skid Tape.....	872
GHS	
Information Centres.....	848
Information Charts.....	847
Safety Labels.....	844
Glow in the Dark Tape.....	870
Handling Labels.....	1448
SDS	
Binders.....	849
Information Centre.....	849
Self-Adhesive Numbers.....	800
Tags, Lockout.....	789
Tape Dispensers, Aisle Marking Tape.....	868
TDG Labels.....	855, 1448
TDG Placards.....	851-854
WHMIS	
Information Charts.....	847
Posters.....	847

INNOVA

Davits.....	491
Extinguishers, Fire.....	652
Manhole Shields.....	491

INTEGRATED PLASTICS

Distribution Containers.....	23, 1564
Small Parts Cabinets.....	34
Stacking Bins.....	5

INTERCON

Weld-On Hinges.....	1088
---------------------	------

IPG

Aluminum Foil Tape.....	1415
Box Sealing Tape.....	1410, 1413
Double Sided Tape.....	1416
Duct Tape.....	1415
Filament Tape.....	1412
Gummed Tape.....	1413
Masking Tape.....	1414
Painter's.....	1050
Shrink Wrap.....	1426
Spray Adhesives.....	1036
Strapping, Tape.....	1412
Stretch Wrap	
Blown.....	1424
Cast.....	1424, 1426
Clear.....	1424
Machine.....	1426
Stretch Wrap Dispensers.....	1426
Tape Dispensers, Gummed Tape.....	1413

IRON GUARD SAFETY

Bump Guard, Forklift.....	186
Bumpers, Dock.....	213
Checklist Kit, Forklift.....	187
Dock Lights, Stop & Go.....	220
Fenders, Dock.....	212
PPE Battery Kit, Forklift.....	186
Security, Gates.....	866
Speed Bumps, Traffic Control.....	860
Spot Lights.....	187
Trailer Jacks.....	212
Wheel Chocks.....	210

IRP INDUSTRIAL RUBBER

Entrance Matting, Rubber.....	901
Hoses, Air.....	1235

IRWIN

Auger Bits.....	1199
Bar Clamps.....	1285-1287
Cable Cutters, Industrial Grade.....	1352
Chalk Lines.....	1279
Clamps, Pipe.....	1285
Drill Bits, Aircraft Extension.....	972
Forstner Bits.....	1199
Vis Grips.....	1352
Woodworking Chisels.....	1367

ITW PRO BRANDS

Stainless Steel Cleaners.....	316
Wipes.....	316, 318

JACKSON SAFETY

ADF Filters.....	1121
Chemical Resistant Gloves.....	589
Filter Plate Lenses.....	1122
Goggles, Welding.....	1120
Ground Clamps, Welding.....	1086

BRAND INDEX

Hand Shields, Welding.....	1123
Helmets, Welding.....	481, 1121-1123
PAPR Respirators.....	470, 481, 1122
Respirators, Cartridges.....	470

JACOBS

Chucks, Drill.....	1268-1269
Tool Holders, ER Collet Chucks.....	1269

JEAMAR WINCHES

Hand Winches.....	195
-------------------	-----

JET EQUIPMENT

Agricultural Jacks.....	208
Dollies, Mechanic's.....	209

JOBOX

Tool Storage	
Chests.....	1402-1403
Jobsite Boxes.....	1401-1407
Van and Truck Equipment.....	1407

JOHNSON

Bevels.....	1280
Carpenter Squares.....	1280
I-Beam Frame Levels.....	1281
Laser Levels.....	1282-1283
Rafter Squares.....	1280
T Squares, Drywall.....	1280
Torpedo Levels.....	1281
Try Squares.....	1280

JOMAC CANADA

Chemical Resistant Gloves.....	592
Cut Resistant Gloves.....	577, 579, 581
Heat Resistant Gloves.....	622-623
Heat Resistant Mitts.....	622
Knit Gloves.....	629
Sleeves	
Cotton.....	528
Kevlar®.....	529

JUSTRITE

Ashtrays.....	236, 284, 657
Bench Cans.....	992
Cabinet Carts.....	660, 662
Cabinets, Drum.....	663, 665
Cans, Safety.....	668-669
Covers, Drum.....	236, 670
Crimpers, Cap Seal.....	250
Dip Tanks.....	992
Dipping Baskets.....	992
Dispenser Bottles.....	672
Drip Cans.....	670
Drum Equipment	
Spill Pallets.....	706-708
Trays.....	681
Funnels, Drum.....	251, 699
Gas Cylinder, Cabinets.....	1077
Gauges, Drum.....	251
Hazardous Materials Cabinets.....	660-667
MSDS, Storage Boxes.....	667
Oily Waste Cans.....	670-671
Plunger Cans.....	670
Rinse Tanks.....	992
Vents, Drum.....	251
Wash Tanks.....	992

KALAS

Cables, Welding.....	1085
----------------------	------

KANT-TWIST

Clamps, Pipe.....	1285
-------------------	------

KEE KLAMP

Kee Klamp® Pipe Fittings.....	79-81
Pneumatic Piping.....	81

KEY-BAK

Chucks, Drill.....	1269
Key Chains.....	1570-1571
Label Holders.....	1571

KILOTECH

Bench Scales.....	1493-1495
Counting Scales.....	1491
Crane Scales.....	203, 1496
Dial Scales.....	1494
Hanging Scales.....	203, 1496
Platform Scales.....	1495
Portable Scales.....	1493
Receiving Scales.....	1494
Test Weights.....	1496
Weighing Scales.....	1491-1492

KIMBERLY-CLARK

Coated Gloves.....	564
Coveralls	
General Protection.....	539
Limited Use.....	539
Cut Resistant Gloves.....	578
Disposable Gloves.....	596-597
Lab Coats, General Protection.....	539
Wipes.....	337-338
Wipes Dispensers.....	338

KIMBERLY-CLARK PROFESSIONAL

Blankets, Welding.....	1118
Helmets, Welding.....	1123
Screens, Welding.....	1118-1119
Umbrellas, Welding.....	1118

KINEDYNE

Cargo Bars.....	212, 1457
Decking Beams.....	212, 1457
Jack Bars.....	1457
Load Binders.....	192
Logistic Straps.....	246, 1456
Logistic Tracks.....	212, 1457
Ratchet Straps.....	1456
Tie-Downs.....	1456-1457

KING CANADA

Arbor Presses.....	208
Bench Grinders.....	917, 1270
Brushes, Parts Cleaning.....	993
Chop Saws.....	914, 1174
Compressors, Air.....	1263
Drill Presses	
Bench.....	1266-1267
Floor.....	1266-1267
Engine Tilters.....	208
Engine-Powered Pumps.....	264
Gearhead Machines, Drilling.....	1267
Guns	
Air.....	1051
Paint.....	1051
Hand Lamps.....	1528
Media Recyclers, Sandblasting.....	1055
Mitre Saws.....	1176
Parts Washers.....	993
Portable Blasters, Sandblasting.....	1055

Shop Cranes.....	208
Work Stands.....	225

KLEEN-FLO

Battery Acid Neutralizers.....	1037
--------------------------------	------

KLEIN TOOLS

Bolt Holder Pliers.....	1349
Cabinet Tip Screwdrivers.....	1339
Cable Cutters	
Industrial Grade.....	1349, 1351
Insulated.....	1377
Crimping Die Pliers.....	1349, 1377
Cross-Point Screwdrivers.....	1339, 1378
Diagonal Cutters.....	1350, 1377
Flat Tip Screwdrivers.....	1339, 1378
Locking Pliers.....	1351
Long Nose Pliers.....	1351, 1377
Needle Nose Pliers.....	1351
Nose Cutting Pliers.....	1350
Nut Drivers	
Cushion Grip.....	1342
Insulated.....	1378
Magnetic.....	1342
Sets.....	1342
Pump Pliers.....	1377
Rebar Tie Wire Cutters.....	1350
Screwdrivers, Sets.....	1339
Side Cutting Pliers.....	1349, 1351, 1377
Slip Joint Pliers.....	1349
Square Screwdrivers.....	1339
Technicians' Tools.....	1378-1379
Tongue & Groove Pliers.....	1349
Tool Storage	
Bags.....	1393, 1464
Belts.....	1389
Holders.....	1387-1388
Pouches.....	1387-1388, 1390-1391
Torque Screwdrivers.....	1329
Torx® Screwdrivers.....	1339
Wire Strippers.....	1351
Wire Stripping Pliers.....	1377

KLETON

Bag Sealing Tape.....	1436
Bar Racks.....	53
Beam Trolleys.....	190
Bin Carts.....	7-8
Bin Racks.....	8-9, 121
Bin Shelves.....	17, 60
Bin Support Panels.....	7
Bins, Steel.....	44
Bollards.....	54, 85
Box Sealing Tape.....	1410
Box Trucks.....	166, 172-173, 175
Bumpers, Dock.....	213
Cabinets, Storage.....	9-10, 99-100
Carton Rack.....	1434
Carts, Welding.....	1078
Casters.....	137, 152-154, 162, 164-165, 176-177, 227-228, 245-246
Corkboards.....	1569
Diaphragm Pumps.....	258
Dollies	
Aluminum.....	177
Drum.....	244
Wood.....	176
Drywall Carts.....	159
Extensions, Forklift.....	187
Faucets, Drum.....	252
Folding Chairs.....	1554
Folding Tables.....	382, 1557
Furniture Pads.....	1454
Gas Cylinder, Cabinets.....	1077
Guard Rails.....	54, 84-85
Hand Pumps.....	256
Hand Trucks.....	144-146, 149-151, 1454, 1554

Hoists, Manual.....	190
Horizontal Sheet Rack.....	53
Lift Tables.....	178
Lifters, Drum.....	238, 243
Locker Room Benches.....	108, 382
Lockers, Steel.....	105
Lumber Carts.....	159-160
Maintenance Platforms.....	141
Mesh Enclosures.....	90
Mesh Partitions.....	51, 84-85, 88-89
Order Picking Carts.....	165
Pallet Pullers.....	186
Pallet Trucks.....	144, 182-183
Panel Trucks.....	160
Perimeter Guards.....	51, 84-85, 88
Pipe Trucks.....	160
Platform Trucks	
Aluminum Deck.....	155-156
Dead Skids.....	154
Non-skid Vinyl Deck.....	156
Plastic Deck.....	156
Semi-Live Skids.....	154
Steel Deck.....	152-153, 155, 160, 165
Wood Deck.....	153-154
Pumps, Drum.....	254-257
Racks, Drum.....	245
Reel Dispensers.....	167
Rockers, Drum.....	245
Rolling Ladders.....	135, 137-138
Rotary Pumps.....	257
Seals, Steel.....	1419
Service Benches.....	123-125
Shelf Carts.....	73, 76, 162-165, 167
Shelving Units	
Chrome.....	17, 70-72, 75
Steel Wire.....	73
Shop Carts.....	164
Shop Desks.....	126
Small Parts Bins.....	31
Small Parts Cabinets.....	30-32, 38
Stackers.....	180
Stacking Bins.....	4-5, 17
Stacking Racks.....	53-54
Stepstands, Steel.....	136
Stepstools, Polyethylene.....	136, 1549
Stock Picking Carts.....	165
Stock Trucks.....	166
Strapping	
Dispensers.....	1420
Machines & Tools.....	1419, 1422
Steel.....	1419
Stretch Wrap Dispensers.....	1424
Strip Curtain Doors.....	92
Tape Dispensers	
Box Sealing Tape.....	1411, 1429
Filament Tape.....	1412
Tarpaulins.....	379, 1453
Tie-Downs.....	683, 1455
Tilt Trucks.....	173
Tipplers, Pail.....	245
Tool Storage, Carts.....	123
Trailer Jacks.....	212
Transfer Boxes.....	19
Trucks, Drum.....	246
Utility Carts.....	76, 166, 168
Valves, Drum.....	252
Vents, Drum.....	251
Vertical Sheet Rack.....	53
Wagons.....	154
Wheel Chocks.....	210
Wheels.....	144, 246
Whiteboards.....	1569
Work Platforms.....	135-136
Work Tables.....	120
Workbenches.....	103, 112-117, 120-123, 1432
Wrenches, Drum.....	250

KNIPEX

Technicians' Tools.....	1379
-------------------------	------

KNUFFI

Edge Protectors.....	87, 216
----------------------	---------

KODIAK POWER EQUIPMENT

Engine-Powered Pumps.....	264
Pressure Washers.....	374-375

KRYLON INDUSTRIAL

Marking Wands.....	1038-1039
--------------------	-----------

Paint

Acrylic.....	1040, 1042-1044
Alkyd.....	1040-1041, 1043-1044
Epoxy.....	1042
Floor.....	1019
High Heat.....	1042-1043
Latex.....	1042
Line Striping.....	1039
Marking.....	1038
Paint Supplies, Paint Remover.....	1039
Striping Machines.....	1039

KUNY'S

Cell Phone, Holders.....	1387, 1390
Suspenders.....	1389

Tool Storage

Aprons.....	1391
Bags.....	1391-1393
Belts.....	1389
Boxes.....	1393
Holders.....	1387-1388
Pouches.....	1387-1388, 1390-1392

KYORITSU

Phase Rotation Testers.....	1468
-----------------------------	------

L.B. WHITE

Fan Forced Heaters.....	1505
Radiant Heaters.....	1504-1505

LA-CO INDUSTRIES INC

Teflon® Tape.....	1416
-------------------	------

LAKELAND

Coveralls, Limited Use.....	538
-----------------------------	-----

LAKESIDE MATERIAL HANDLING

Equipment Stands.....	170
Shelf Carts.....	170
Utility Carts.....	170

Laurin

Tilt Trucks.....	172
------------------	-----

LAVO

Bleach.....	314
-------------	-----

LENCO

Cable Connectors, Welding.....	1084
Chipping Hammers, Welding.....	1087

LEPAGE

Wood Fillers.....	1022
-------------------	------

LEV-CO

Air Filters.....	1058
Fume Extractor Fans.....	1058

Fume Extractors.....	1058-1060
Fume Filters, Welding.....	1058-1059
Mechanical Filters.....	1059
Portable Blowers.....	1059
Pressure Gauges, Dial.....	1058

LEWIS BINS+

Distribution Containers.....	18, 20
Dollies, Stacking.....	20
ESD Products, Bins.....	25

LIFE SAFE

Snow Clearing Posts.....	871
--------------------------	-----

LIFT-RITE

Pallet Lifters.....	184
Pallet Trucks.....	186
Stackers.....	180

LINCOLN ELECTRIC

Cold Wire Feeders, TIG Torch.....	1091
MIG Welders.....	1092-1093
Plasma Cutters.....	1090
Stick Electrodes.....	1136
TIG Welders.....	1091
Water Cooled Torches.....	1091

LIND EQUIPMENT

Batteries, C Cell.....	444, 1518
Bonding & Grounding Wires.....	252-253
Cable Protectors, Dock.....	217

Cord Reels

Extension Cords.....	1531-1532, 1537
Fluorescent.....	1532
Incandescent.....	1531-1532
Quad Box.....	1531
Single Outlet.....	1531
Triple Outlet.....	1532
Work Lights.....	1531

Cord Sets, GFCI.....	1539
----------------------	------

Dock Lights

Flexible.....	218
Halogen.....	218
Single Strut.....	218

Extension Cords

Circuit Breaker.....	1538
Single Outlet.....	1538

Floodlights.....	1526-1528
------------------	-----------

Floor Lamps.....	1527
------------------	------

Fluorescent Lamps / Light Bulbs.....	1525-1526
--------------------------------------	-----------

Halogen Lamps / Light Bulbs.....	1527-1528
----------------------------------	-----------

Hand Lamps.....	1525-1527
-----------------	-----------

Headlights, Hard Hat.....	419
---------------------------	-----

Outlet Adaptors, GFCI.....	1540
----------------------------	------

Outlet Boxes, GFCI.....	1539
-------------------------	------

Plugs, GFCI.....	1540
------------------	------

Spot Lights.....	1518
------------------	------

String Lights.....	1528
--------------------	------

Telescopic Lights.....	1528
------------------------	------

LISTA

Cabinets, Storage.....	94-96
Open Wire Workstations.....	118
Shelving, Drawer Insert.....	68-69
Workbenches.....	118-119

LITTLE GIANT PUMP COMPANY

Coolant Tanks.....	1150
Machine Tool Pumps.....	1150
Multi-Purpose Ladders.....	1150
Submersible Pumps.....	262-263, 1150
Transfer Pumps.....	263

BRAND INDEX

LLOYDS

Air Tool Oil.....	1037, 1261
Graffiti Removers.....	319, 1005

LOC-LINE

Loc-Line® Hosing.....	1150-1153
-----------------------	-----------

LOCTITE

Accelerators, Adhesive.....	1032
Adhesives	
Acrylic.....	1034
All Purpose.....	1023
Aluminum Foil Tape.....	1020
Anti-Seize.....	1016
Anti-Slip Floor Coatings.....	873, 1019
Bolt Removal Penetrants.....	1013
Caulking Guns.....	1035
Construction Adhesives.....	1029
Contact Cleaners.....	1007
Dielectric Greases.....	1018
Epoxies	
for Metal.....	1020-1021
General Purpose.....	1033-1034
Mixer Cups.....	1021
Putty.....	1020-1021
Syringe.....	1021
Two Part.....	1033
Epoxy Applicators.....	1021, 1035
Fault Detectors, Welding.....	1012, 1148
Flange Sealants.....	1026
Floor Repair.....	1019, 1021
Floor Sealers.....	1019
Gaskets.....	1025-1026
Glue Guns.....	1035
Guns, Air.....	1035
Instant Adhesives.....	1031-1032
Paint, Rubber.....	1012
Primers, Adhesive.....	1032
Retaining Compounds.....	1027
Rust Converters.....	1014, 1146
Sealants, Silicone.....	1025
Spray Lubricants.....	1018
Structural Adhesives.....	1032-1034
Synthetic Greases.....	1018
Teflon® Tape.....	1028
Thread Sealants.....	1026
Threadlockers.....	1020, 1027-1028
White Lithium Greases.....	1018

LOUISVILLE LADDER

Double Stepladders.....	130-131
Platform Ladders.....	130
Scaffolding.....	134
Stepstools, Fiberglass.....	134

LPS

Anti-Seize.....	1016
Anti-Spatter.....	1147
Bearing Greases.....	1017
Belt Dressing.....	1012
Brake Cleaners.....	1005
CFC Free Degreasers.....	1002
Contact Cleaners.....	1005-1006
Cutting Fluids, for all Metals.....	1149
Degreasers	
Heavy-Duty.....	1002-1003
Multi-Purpose.....	1002-1004
Dusters, Aerosol.....	1006
Galvanizing Compounds.....	1014, 1146
Hand Towels.....	334, 1005
High Temperature Greases.....	1017
Industrial Cleaners, Multi-Purpose.....	1003
Machinery Oil.....	1011
Multi-Purpose Greases.....	1011, 1018

Penetrants

KB 88.....	1013
Multi-Purpose.....	1013
Permanent Markers.....	1442
Rust Preventers.....	1014, 1146
Solvent Free Degreasers.....	1002-1003
Spray Lubricants.....	1008-1011, 1013
White Lithium Greases.....	1018

LUFKIN

Measuring Tape	
Oil Gaging.....	1279
Retractable Blade.....	1276, 1278
Measuring Wheels.....	1278
Plumb Bobs.....	1279

LUXO

Magnifiers, Illuminated.....	1524
------------------------------	------

LUXOR H. WILSON

Audio-Visual Carts.....	1561
Computer Carts.....	1561
Work Tables.....	1556, 1561

LYON

Cabinets, Storage.....	98-99
Lockers, Steel.....	108
Shelving Units, Steel.....	58

M & P TOOL PRODUCTS

Bins, Steel.....	44
------------------	----

MAGIC

Stations, Lens Cleaning.....	409
Tissues, Lens Cleaning.....	409

MAGLINER

Dollies, Aluminum.....	177
Hand Trucks.....	148-149
Wheels.....	148

MAGLITE

Flashlights	
AA Cell.....	1511
AAA Cell.....	1509-1510
Belt Holsters.....	1509-1511
CR123 Cell.....	1511
D Cell.....	1509-1510
Mini.....	1509
Rechargeable.....	1511
Traffic Wands.....	1509

MAG-MATE

Bar Magnets.....	1298
Ceramic Magnets.....	1299
Cup Magnets.....	1299
Ground Clamps, Welding.....	1086
Grounds, Welding.....	1086
Inspection Mirrors.....	883
Magnetic Lifters.....	198, 1298
Magnetic Retrievers.....	1297-1298
Print Holders.....	1298
Rare Earth Magnets.....	1299
Squares, Welding.....	1086
Strip Magnets.....	1298
Sweeper Magnets.....	286
Sweepers.....	286

MAGNAFLUX

Fault Detectors, Welding.....	1020, 1144
Non-Chlorinated Cleaners.....	1020, 1144
Non-Chlorinated Developers.....	1020, 1144
Penetrants, Water Based.....	1144

MAKITA

Angle Drills, Electric.....	1184
Angle Grinders, Electric.....	916, 1163, 1168-1169, 1171
Battery Chargers, Cordless Drill.....	1167
Chop Saws.....	1174
Circular Saws, Heavy-Duty.....	1177
Combo Kits.....	1164-1166
Compressors, Air.....	1262
Cordless Power Tool Batteries 1156-1157, 1160-1161, 1164, 1167	
Cordless Screwdrivers.....	1161, 1187
D Handle Drills.....	1183
Demolition Hammers.....	1187
Die Grinders, Electric.....	1172
Drills, Drill / Drivers - Cordless.....	1156-1158
Flashlights	
12 V.....	1162
18 V.....	1162
Rechargeable.....	1162
Hand Powered Drills.....	1182
Heat Guns.....	1190
Impact Wrenches	
Cordless.....	1160
Electric.....	1181
Jig Saws	
Heavy-Duty.....	1178
Orbital.....	1178
Mitre Saws.....	1175
Nibblers.....	1173
Palm Sanders.....	1180
Power Scrapers.....	1186
Reciprocating Saws, Electric.....	1179
Shears, Power.....	1173

MALLORY

Extension Poles.....	297, 299
Round Nose Pliers.....	364
Snow Brushes.....	364
Snow Shovels.....	364
Squeegees.....	296, 299
Window Washers.....	299

MAPA PROFESSIONAL

Chemical Resistant Gloves.....	585, 589-590
--------------------------------	--------------

MARIGOLD INDUSTRIAL

Chemical Resistant Gloves.....	585, 589-590, 588-589
Gloves, High Voltage.....	558

MARINO

Bags, Laundry.....	303
Boot Brushes.....	291
Broom & Mop Racks.....	286
Buckets.....	306
Carts, Laundry.....	303
Floor Scrapers.....	292
Garbage Cans.....	272
Hand Scrubbers.....	302, 320
Litter Pickers.....	282, 383
Litter Scoops.....	282, 383
Magnetic Brooms.....	290
Nippers, End Cut.....	282, 383
Plungers, Toilet.....	349
Trigger Sprayers.....	302, 320

MARKAL

Grease Pencils.....	1142, 1445
---------------------	------------

Liquid Tip Markers.....	1445
Lumber Crayons.....	1142, 1444
Metal Markers.....	1444
Paint Markers.....	1142, 1443-1444
Paint Sticks.....	1142, 1443-1444
Permanent Markers.....	1445
Teflon® Tape.....	1027
Temperature Crayons.....	1142, 1445
Whiteboard Markers.....	1569

MARLEY INDUSTRIAL PRODUCTS

Portable Blowers.....	1060
Portable Heaters.....	1504
Radiant Heaters.....	1504
Wall Heaters.....	1504

MARSH

Fountain Brushes.....	799
Fountain Rollers.....	799
Hand Rollers.....	799
Stencil Inks.....	799

MASTER LOCK

Ball Valve Lockouts.....	780, 782-784
Bungee Cords.....	1455, 1457
Butterfly Valve Lockouts.....	783
Cable Lockouts.....	779
Circuit Breaker Lockouts.....	781
Dielectric Hasp Lockouts.....	780
Electrical Plug Lockouts.....	781
Electrical Switch Lockouts.....	781
Gate Valve Lockouts.....	784
Hasp Lockouts.....	764, 768-769, 780
Key Cabinets.....	1570
Key Tags.....	1570
Lock Labels.....	770
Lockouts	
Confined Space.....	784
Kits.....	772, 778-779
Stations.....	773-775
Padlock Caddy.....	773
Padlocks.....	110, 764-772
Pneumatic Fitting Lockouts.....	1250
Safes.....	1577
Tie-Downs.....	1456

MAT TECH

Anti-Fatigue Matting.....	908-909
Entrance Matting	
Carpet.....	886-887
Eco.....	886
Needle Rib.....	885
Pile.....	885-887
Polypropylene.....	885
Rubber.....	886-887, 909
Wiper.....	874, 885-887

MATRIX INDUSTRIAL PRODUCTS

Ceiling Mounted Heaters.....	1504
Drum Fans.....	1502
Fan Forced Heaters.....	1503
Floor Fans.....	1499
Office Fans.....	1499
Pedestal Fans.....	1497, 1499
Radiant Heaters.....	1503
Radiator Heaters.....	1503
Wall Clocks.....	1575
Wall Mounted Fans.....	1497, 1499

MAYFIELD

Funnels, Steel.....	993
Liquid Measures.....	993

MECHANIX WEAR

Anti-Vibration Gloves.....	606
Ergonomic Products, Gloves.....	602, 605
Impact Gloves.....	606
Leather Gloves.....	621, 1131

MEGAPRO

Multi-Tip Screwdrivers.....	1341
-----------------------------	------

MEGGER

Insulation Testers.....	1467
-------------------------	------

MELNOR

Garden Hoses.....	378
Guns, Garden Hose.....	376
Oscillators, Garden Hose.....	376
Repair Kits, Hose.....	377
Sprinklers, Garden Hose.....	376
Timers, Mechanical.....	378

MERIT

Backing Pads.....	922
Cartridge Rolls.....	929
Disc Holder Pads.....	922, 924
Flap Wheels.....	920
Power-Lock Discs.....	924
Resin Fibre Discs.....	922
Spiral Bands.....	929

METABO

Hammer Drills.....	1184
Heat Guns.....	1190

METALTECH

Extension Ladders.....	135
Scaffolding.....	141-143

METALWARE

Shelving Units	
Steel.....	62-67
Widespan.....	57

METRO

Garbage Cans.....	169
Security, Carts.....	77
Shelf Carts.....	77
Shelving Units	
Chrome.....	74
Plastic.....	75
Steel Wire.....	75
Utility Carts.....	169
Workbenches.....	120

MICRELL

Hand Cleaners, Lotion.....	324
Soap Dispensers.....	324

MIDWEST

Table Caddies.....	1557
--------------------	------

MILLER BY HONEYWELL

Anchorage Connectors.....	519
Arc Rated Harness.....	500, 560
Arc Rated Lanyards.....	510, 560
Beam Clamps.....	519
Beam Trolleys.....	519
Carabiners.....	520
Cross-Arm Strap Anchors.....	519, 560

D-Bolt Anchors.....	519
Fall Protection, Harnesses.....	497-499
Fall Protection Kits.....	505
Rescue Systems.....	492
Rope Grabs.....	520
Self-Retracting Life Lines.....	514-515
Shock Absorbing Lanyards.....	508-510
Tie-Back Lanyards.....	509-510
Vertical Life Lines.....	520
Welding Harnesses.....	500
Welding Lanyards.....	510

MILLSIDE

Wagons.....	370
-------------	-----

MILWAUKEE

Angle Drills, Electric.....	1184
Angle Grinders, Electric.....	916, 1163, 1168-1170
Bandsaws	
Metal Cutting.....	1178
Wood Cutting.....	1178
Battery Chargers, Cordless Drill.....	1167
Chop Saws.....	914, 1174
Circular Saws, Heavy-Duty.....	1162, 1177
Close Quarter Drills.....	1184
Combo Kits.....	1164-1166
Cordless Power Tool Batteries.....	1156-1164, 1167
Core Bits.....	1194
Coring Motors.....	1189
D Handle Drills.....	1183-1184
Die Grinders, Electric.....	1172
Drill Bits	
Hex Shank.....	1198
Through-Hole.....	1199
Two-Piece.....	1193
Drill Presses, Electromagnetic.....	1188-1189
Drills, Drill / Drivers - Cordless.....	1156, 1161, 1164
Flashlights	
12 V.....	1162
Rechargeable.....	1162
Floodlights.....	1162
Grease Guns.....	1161
Hammer Drill / Drivers.....	1157-1159
Hammer Drills.....	1158-1159, 1185-1187
Hand Chisels.....	1194
Hand Powered Drills.....	1182-1183, 1186
Heat Guns.....	1190
Hole Saw Arbors.....	1193, 1198
Hole Saws.....	1197-1198
Impact Wrenches	
Cordless.....	1159-1160
Electric.....	1181
Infrared Thermometers.....	1470
Jig Saws, Orbital.....	1178
Knockout Tools.....	1162
Mitre Saws.....	1176
Nibblers.....	1173
Palm Sanders.....	1180
Points, Cutting.....	1194
Reciprocating Saw Blades.....	1201
Reciprocating Saws	
Cordless.....	1163
Electric.....	1179
Rotary Cutters.....	1163
Rotary Hammers.....	1159, 1186-1187
Scaling Chisels.....	1194
Screw Guns.....	1187
Shears, Power.....	1173

MMF INDUSTRIES

Key Cabinets.....	1570
Key Racks.....	1570
Key Tags.....	1570

BRAND INDEX

MOBILE INDUSTRIES

Pallet Trucks.....	184-186
Stackers.....	180

MOLDEX

Disposable Respirators.....	450-451
Ear Muffs	
Headband.....	435
Hygiene Kits.....	435
Ear Plugs	
Dispensers.....	427
Disposable.....	426
Reusable.....	426, 429
Full Face Respirators.....	462
Half Mask Respirators.....	462
Hearing Bands.....	431
Respirators	
Cartridges.....	462
Welding.....	450

MONOFLO INTERNATIONAL, INC.

Pallets, Plastic.....	47
-----------------------	----

MORSE

Dollies, Drum.....	244
Funnels, Drum.....	241
Lifters, Drum.....	239-243
Rotators, Drum.....	248
Spotters, Drum.....	247
Tilters, Drum.....	239-240
Trucks, Drum.....	247
Tumblers, Pail.....	248
Upenders, Drum.....	250
Wrenches, Drum.....	250

MOTOROLA

Two-Way Radios.....	441-442
---------------------	---------

MR. CHAIN

Chain, Crowd Control.....	880
Posts, Crowd Control.....	880

MR. CLEAN

Floor Cleaners.....	317
---------------------	-----

MRB

Shrink Wrap Machines.....	1426
---------------------------	------

MSA

Docking Stations.....	485-486
Ear Muffs, Cap Mounted.....	439
Faceshields.....	413
Full Face Respirators.....	463
Gas Detectors	
Calibration Gas.....	485-486
Sensor.....	485-486
Half Mask Respirators.....	463-464
Hard Hats.....	417-418
Multi-Gas Detectors.....	485-486
Regulator, Calibration Gas.....	485-486
Respirators	
Cartridges.....	463-464
Filters.....	464
Single-Gas Detectors.....	485

MUR-VAN

Casters.....	1550
Office Seating.....	1554
Swivel Stools.....	1554
Task Seating.....	1550-1552, 1554

MUSCLE MATE

Bins, Steel.....	45
Floor Cranes.....	200, 202
Gantry Cranes.....	200
Jib Booms.....	201
Jib Cranes.....	201
Pallet Lifters.....	201
Shop Cranes.....	202
Truck Mounted Cranes.....	202

NALGENE

Bottles, Storage.....	28
Jars, Storage.....	28

NAS

Shelving Units, Steel.....	57
Tire Racks.....	78

NASHVILLE WIRE

Collapsible Containers.....	44
-----------------------------	----

NEOS

Overshoes.....	634
----------------	-----

NEPTUNE

Mixers	
Drum.....	249
Pail.....	249

NEXAL

MIG Wire, Aluminum.....	1138
-------------------------	------

NICHOLSON

File Cleaners.....	1307
File Handles.....	1307
Files, Sets.....	1306-1307
Flat Files.....	1302-1305
Hacksaws	
Blades.....	1300
Frames.....	1301
Half Round Files.....	1303
Half Round Rasps.....	1305
Round Files.....	1302, 1304
Round Rasps.....	1305
Square Files.....	1304
Thread Repair, Files.....	1307
Triangular Files.....	1304-1305

NILFISK

Vacuums, Wet / Dry.....	361, 688
-------------------------	----------

NOGA

Deburring Hand Tools.....	1308
---------------------------	------

NORTECH

Vacuums, Wet / Dry.....	361
-------------------------	-----

NORTH BY HONEYWELL

Anchorage Connectors.....	519
Bump Caps.....	417
Carabiners.....	520
Chemical Resistant Gloves.....	584, 592
Davits.....	491
Disposable Respirators.....	452
Emergency Escape Respirators.....	459
Faceshields.....	410-411
Fall Protection, Harnesses.....	501-502, 519
Fall Protection Kits.....	505-506

Full Face Respirators.....	458-459, 469
Glasses, Safety.....	397-398
Half Mask Respirators.....	458, 469
Hard Hats.....	416-417
PAPR Respirators.....	480
Rescue Hoist.....	492
Rescue Systems.....	492
Respirators	
Cartridges.....	460, 480
Filters.....	452, 459, 480
Rope Grabs.....	520
Sandblasting Gloves.....	591
Self-Retracting Lanyards.....	515
Self-Retracting Life Lines.....	515
Shock Absorbing Lanyards.....	510
Vertical Life Lines.....	520

NORTON

Backing Pads.....	927
Benchstand Belts.....	929
Circular Saw Blades.....	914
Crimped Filament Wheels.....	912-913
Cut-Off Wheels.....	912-915
Flap Discs.....	918-919
Grinding Wheels	
Bench Mounted.....	917, 1271
Type 27.....	915-916
Zirconium.....	913-915
Grip-On Discs.....	926
Portable Belts.....	928
Portable File Belts.....	928
Power-Lock Discs.....	924
Sandpaper.....	931
Stick-On Discs.....	926-927
Surface Conditioning Discs.....	934
Surface Conditioning Pads.....	933
Surface Conditioning Rolls.....	930, 934

NUCO

Caulking Guns.....	1023
Construction Adhesives.....	1029
Epoxies	
General Purpose.....	1023
Putty.....	1023
Foam Sealants.....	1023

OASIS

Water Filters.....	1585
Water Fountains.....	1585-1586

OATEY

Pipe Cements.....	1022
Plumbers' Putty.....	1022
Teflon® Tape.....	1416

OBERDORFER

Pumps, Drum.....	258
------------------	-----

OETIKER INC

Hose Repair Kits, Welding.....	1075
--------------------------------	------

OHAUS

Bench Scales.....	1491-1492, 1495
Floor Scales.....	1496
Platform Scales.....	1495
Portable Scales.....	1492

OIL-DRI

Absorbents.....	684
-----------------	-----

OLD DUTCH

Scouring Powder.....316

OLFA

Blades, Packaging Knife.....1425, 1430, 1434, 1438-1439, 1442
Cases, Blade Disposal.....1438
Knives, Packaging.....1425, 1430, 1434, 1438-1439, 1442
Scissors, Industrial.....1442
Utility Knives.....1442

OLYMPIC

Wire Measurers.....1484

OMEGA COMPRESSORS

Compressors, Air.....1263

OMNIGLOW

Lightsticks.....860

ONGUARD INDUSTRIES

Boot Covers.....632
Chemical Resistant Boots.....631
Chest Waders.....633
Hip Waders.....633
Knee Boots.....631-632
Overboots.....633
Overshoes.....633
Work Boots.....632

OPTREL

ADF Filters.....1124-1125
Beanies, Welding.....1125
Chest Protectors, Welding.....1125
Helmets, Welding.....1124-1125
Neck Protectors, Welding.....1125

ORBIS

Collapsible Containers.....45
Distribution Containers.....22-23
ESD Products, Bins.....25
Pallets, Plastic.....46-48, 1423

OSBORN

Brushes
Acid.....1141, 1145
Parts Cleaning.....993
Compressors, Air.....1264-1265
Paint Supplies, Brushes.....1046
Scrub Brushes.....291, 946
Wheel Brushes.....941, 1271

PACER

Pumps, Drum.....258

PANAVISE

Tilting Vises.....1296

PAPER MATE

Pencils.....1578
Pens, Office.....1578

PARCO

Bicycle Racks.....379

PARTLOW

Temperature Recorders.....1476

PELICAN

Cell Phone
Accessories.....443
Holders.....443
Equipment Cases.....1465
Flashlights
AA Cell.....1514, 1516, 1518
AAA Cell.....1514
C Cell.....1516
Coin.....1514
Mini.....1514
Waterproof.....1518
Floodlights.....1530
Task Lights.....1530

PELTOR

Ear Muffs
Cap Mounted.....436-438
Headband.....436-438
Neckband.....436-437
Two-Way Radios.....438-439

PERFIX INC.

Filing Cabinets, Lateral.....1563
Lockers, Steel.....107

PESOLA

Hanging Scales.....1493

PHOENIX INTERNATIONAL

Electrode Ovens.....1089
Rod / Electrode Containers.....1089

PICQUIC

Hex Square Drive Bits.....1340
Multi-Tip Screwdrivers.....1340

PLASTIC RECYCLING

Bollards.....865
Park Benches.....380
Parking Curbs, Traffic Control.....861
Picnic Tables.....380

PLASTICOR

Anti-Fatigue Matting.....906

PLEDGE

Furniture Polish.....319

PLUMB

Ball Pein Hammers
Fiberglass Handle.....1365
Wood Handle.....1365
Blacksmiths' Hammers.....1366
Brick Hammers.....1364
Claw and Ripping Hammers.....1364
Claw Hammers.....1364
Curved Claw Hammers.....1364
Double Faced Hammers.....1366
Scaling Hammers.....1364

POLARPRO

Forks, Cafeteria.....1583
Knives, Cafeteria.....1583
Spoons, Cafeteria.....1583

POLYAIR

Bubble Mailers.....1435

Bubble Pouches.....1435
Bubble Wrap.....1427
Foam, Packaging.....1427

PORTER CABLE

Belt Sanders, Electric.....1180

POST-IT

Message Pads.....1579

PR88

Hand Creams.....333

PRECISION BRAND

Feeler Gauge Stock.....1274
Shims.....1273-1274
Stock.....1274

PRECISION TWIST DRILL

Combined Drills & Countersinks.....961
Drill Bits
Jobber.....949-953
Silver & Deming.....954
Stub.....953-954
Taper Shank.....955

PRIME

Cord Reels, Extension Cords.....1537
Cord Sets, GFCI.....1539
Extension Cords
Double Outlet.....1541
Single Outlet.....1536, 1538, 1541
Triple Outlet.....1535-1536
Power Bars.....1541
Power Strips, GFCI.....1540-1541

PROBUILT PROFESSIONAL

Flashing Lights.....863
Fluorescent Lamps / Light Bulbs.....1529-1530
Task Lights.....1529-1530

PRODUITS RE-PLAST

Park Benches.....380
Picnic Tables.....380

PROTECTA

Anchorage Connectors.....516
D-Bolt Anchors.....516
Fall Protection, Harnesses.....496
Fall Protection Kits.....507
Rescue Systems.....490
Rope Grabs.....517
Self-Retracting Lanyards.....513
Self-Retracting Life Lines.....513
Shock Absorbing Lanyards.....508
Welding Harnesses.....496

PROTECTIVE LINING CORP

Inserts, Pail.....235
Liners, Drum.....235

PS DOORS

Security, Gates.....84

BRAND INDEX

PTC INSTRUMENTS

Hardness Testers	
Non-Metals.....	1479
Steel & Alloys.....	1479

PURDY

Paint Supplies, Brushes	1048
-------------------------------	------

PURELL

Hand Sanitizer Dispensers.....	323-324
Hand Sanitizers.....	323-324, 760

PYROCHEM

Extinguishers, Fire.....	652
--------------------------	-----

QRP

Disposable Gloves.....	596, 598
Fingercots.....	600

QUALITY RAILINGS

Dock Equipment	
Dockboards.....	215
Dockplates.....	215
Twin Ramps.....	214
Walkkramps.....	214
Wheel Risers.....	215

QUANTUM STORAGE SYSTEM

Bin Racks.....	39
Bin Shelves.....	16, 21, 59
Cabinets, Storage.....	35
Distribution Containers.....	19
Gaylord Liners.....	4
Mobile Bins.....	6
Nesting Bins.....	19, 26
Shelf Bins.....	13, 15, 25
Small Parts Bins.....	25, 39
Stacking Bins.....	6, 13, 16, 21, 26
Storage, Stacking Bins.....	4

QUARTET

Audio-Visual Carts.....	1560
Whiteboard Dry Erase Wipes.....	1569

RABCO

Boot Brushes.....	889
-------------------	-----

RALSTON MIRRORS

Inspection Mirrors.....	883
-------------------------	-----

RAYTEK

Infrared Thermometers.....	1469
----------------------------	------

RED KAP

Coveralls, Work.....	550
Lab Coats.....	550
Pants, Work.....	550
Shirts, Work.....	550
Shop Coats.....	550

REED

Air Quality Monitors.....	487, 1474
Alligator Clips.....	1460, 1463
Batteries, 6 Volt.....	1470
Bi-Metal Thermometers.....	1473
Carbon Monoxide Meters.....	487
Circuit Testers.....	1461

Clamp Meters

AC / DC.....	1466
Current Clamps.....	1461, 1466, 1468, 1540
True RMS.....	1460, 1466

Combustible Gas Detectors.....

Conductivity Meters.....	1490
Digital Thermometers.....	1473
Equipment Cases.....	1461, 1464, 1471
Force Gauges.....	1484

Hardness Testers

Non-Metals.....	1479
Steel & Alloys.....	1479

Heat Stress Meter.....

Humidity Meters, Infrared.....	1475
--------------------------------	------

Hygrometers, Thermo.....	1474, 1476
--------------------------	------------

Infrared Thermometers.....	1469-1470
----------------------------	-----------

Inspection Cameras.....	1376, 1485
Borescope.....	1485

Insulation Testers.....	1467
-------------------------	------

Integral Probe Anemometers.....	1486-1487
---------------------------------	-----------

Laser Distance Kits.....	1482
--------------------------	------

Laser Levels.....	1461
-------------------	------

LCR Meters.....	1468
-----------------	------

Light Meters, Digital.....	1481
----------------------------	------

Manometers.....	1487-1488
-----------------	-----------

Moisture Meters.....	1477
----------------------	------

Motor Rotation Testers.....	1468
-----------------------------	------

Multimeters

AC/DC.....	1460, 1462
Electrical.....	1460
True RMS.....	1460

ORP Meters.....	1490
-----------------	------

pH Meters.....	1490
----------------	------

Porosity Detectors.....	1478
-------------------------	------

Pressure Gauges

Dry.....	1232, 1489
Liquid Filled.....	1489

Psychrometers.....	1475
--------------------	------

Refractometers.....	1490
---------------------	------

Sound Level Meters

Digital.....	440, 1480
Integral Probe.....	440, 1480-1481

Stem Thermometers.....	1473
------------------------	------

Stopwatches.....	645, 1475, 1483
------------------	-----------------

Stroboscopes.....	1483
-------------------	------

Surface Mount Thermometers.....	1473
---------------------------------	------

Tachometers.....	1482
------------------	------

Tally Counters.....	1483
---------------------	------

Temperature Probes.....	1471, 1475
-------------------------	------------

Test Leads.....	1463
-----------------	------

Test Probes.....	1463
------------------	------

Testers, Multi-Function.....	1462
------------------------------	------

Thermal Cameras.....	1470
----------------------	------

Thermocouple Probes.....	1471
--------------------------	------

Thermocouple Thermometers.....	1429, 1471, 1474-1475
--------------------------------	-----------------------

Thermometer / Hygrometers.....	645, 1474-1476
--------------------------------	----------------

Thickness Gauges.....	1478-1479
-----------------------	-----------

Vane Anemometers.....	1486
-----------------------	------

Vibration Meters.....	1484
-----------------------	------

Voltage Testers.....	1462
----------------------	------

REELCRAFT

Cord Reels

Fluorescent.....	1532
Single Outlet.....	1532

Hose Reel Carts.....	1237
----------------------	------

Hose Reels.....	1235-1237, 1532
-----------------	-----------------

RELTON

Cutting Fluids

for all Metals.....	1148
for Aluminum.....	1148

Drill Bits

Masonry.....	1196
Splines-Shank.....	1196

Rotary Hammer Bits.....	1195-1196
-------------------------	-----------

REMCO PRODUCTS

Scoops, Spill Control.....	687
Scrapers, Spill Control.....	687
Shovels, Spill Control.....	686
Squeegees.....	687

REMCON PLASTICS INCORPORATED

Lockers, Plastic.....	110
-----------------------	-----

RICHARD

Blades, Packaging Knife.....	1440-1441
------------------------------	-----------

Flooring Knives.....	1441
----------------------	------

Hawks.....	1053
------------	------

Knives

Drywall.....	1053
Packaging.....	1440

Linoleum Knives.....	1441
----------------------	------

Mixers, Paint.....	1046
--------------------	------

Paint Supplies, Accessories.....	1050
----------------------------------	------

Putty Knives.....	1052
-------------------	------

Razor Blades.....	1052
-------------------	------

Roofing Knives.....	1441
---------------------	------

Rubber Cutting Knives.....	1441
----------------------------	------

Sanders, Hand.....	1053
--------------------	------

Sanding Blocks.....	1053
---------------------	------

Saws, Drywall.....	1053
--------------------	------

Scrapers, Drywall.....	1052
------------------------	------

Spreaders, Adhesive.....	1053
--------------------------	------

Trowels, Drywall.....	1053
-----------------------	------

Utility Knives.....	1440-1441
---------------------	-----------

RIDGID

Chain Wrenches.....	1372
---------------------	------

Compound Leverage Wrenches.....	1372
---------------------------------	------

Drain Augers.....	1375
-------------------	------

End Wrenches.....	1373
-------------------	------

Flaring Tools.....	1374
--------------------	------

Hex Wrenches.....	1372
-------------------	------

Inspection Cameras.....	1376, 1485
-------------------------	------------

Offset Wrenches.....	1373
----------------------	------

Spud Wrenches.....	1372
--------------------	------

Straight Wrenches.....	1373
------------------------	------

Strap Wrenches.....	1372
---------------------	------

Toilet Augers.....	1375
--------------------	------

Tubing Cutters.....	1374
---------------------	------

Wrenches, Pipe.....	1373
---------------------	------

RIEKE

Wrenches, Drum.....	250
---------------------	-----

RMP

Buckets.....	307
--------------	-----

Carts, Janitorial.....	309
------------------------	-----

Degreasers

Heavy-Duty.....	312, 315
Multi-Purpose.....	312

Disinfectants.....	314, 318
--------------------	----------

Floor Cleaners.....	310
---------------------	-----

Floor Signs.....	308
------------------	-----

Garbage Bags.....	280-281
-------------------	---------

Hand Cleaners

Gel.....	315, 326
Liquid.....	315, 326
Lotion.....	315, 326-327

Industrial Cleaners, Multi-Purpose.....	312
---	-----

Toilet Bowl Cleaners.....	314
---------------------------	-----

Wringers.....	307
---------------	-----

RODO INDUSTRIES INC.

Folding Tables.....	1557
---------------------	------

ROPAK

Pails 27

ROSS H. BARBER

Water Filters 1586

RUBBERMAID

Air Fresheners 321-322

Angled Brooms 290

Ashtrays 283, 285, 383

Bathroom Faucets 350

Broom & Mop Racks 286

Buckets 306-307

Cabinets, Storage 98, 381

Caddy, Waste Container 266

Carts

Janitorial 275, 309

Laundry 303

Changing Tables 348

Cones, Crowd Control 296, 308

Containers, Poly 27

Coolers, Containers 1586

Corn Brooms 289

Dollies

Drum 244, 266

Waste Container 266, 276-277

Dusters, Janitorial 294, 320

Dustpans 290, 296

Expandable Gates 309

Extension Poles 288, 292, 294

Filing Trays 1577

Floor Signs 308

Food Handling Containers 175

Frames, Dust Mop 294-295

Garbage Cans 266-270, 272-275, 383, 761, 1577

Hand Scrubbers 292

Hoppers, Self-Dumping 171

Ladder Trucks 134

Lids, Waste Container 266, 268, 272, 276-277

Liners, Waste Container 267, 269-270, 273, 285

Measuring Cups 317

Microfiber Cloths 294

Mops

Dust 295

Wet 294, 304, 306

Pads, Cleaning 294

Panel Trucks 158-159

Platform Trucks

Plastic Deck 156-158

Semi-Live Skids 158

Structural Foam Deck 157

Portable Scales 1494

Push Brooms 288, 290

Recycling Containers 276-277, 1577

Sanitary Napkin Receptacles 349

Sheds, Portable 381

Shelf Carts 168

Shop Carts 169

Stacking Bins 26

Stacking Racks 157

Stepstools, Polyethylene 136, 1549

Sweepers 286

Tilt Trucks 172

Toilet Auto Flush Adapter 350

Trades Carts 169

Utility Carts 168-169

Wagons 157

Wheelbarrows 172, 370

Wringers 294, 307

RUBBERSET

Extension Poles 1048

Paint Supplies

Brushes 1047-1048

Foam Rollers 1049

Roller Covers 1049-1050

Rollers 1049-1050

Trays, Paint 1050

RUPTURESEAL

Spill Control, Leak Seal 683

RUST STOP

Rust Removers 1014, 1146

RUST-OLEUM

Caulking Guns 1018, 1045

Cleats 872

Coating, Hydrophobic 1045

Floor Repair 1018, 1045

Marking Paint 1040

Marking Wands 1040

Paint

Acrylic 1044

Alkyd 1041, 1043

Antislip 1045

Applicator 1040

Epoxy 1043

Floor 1019, 1044-1045

High Heat 1042

Line Striping 1039

Marking 1038

Rubber 1045

Sprayers, Paint 1042

Striping Machines 1039-1040

SAFCO

Audio-Visual Carts 1560

Chair Caddies 1554

Coat Racks 1581

Coffee Equipment 1584

Computer Desks 1560

Desk Lamps 1582

Ergonomic Products, Seating 1547

Filing Cabinets

Lateral 1565

Oversized Files 1566

Vertical 1565

Footrests 1549

Hangers, Clothes 1581

Mail Sorters 1566

Paper Clamps, Hanging 1565

Recycling Containers 278

Suggestion Boxes 1581

Task Seating 1550, 1552

Whiteboards 1569

SAFEBLEND

Air Fresheners 314

Antimicrobial Soap 326

Carpet Cleaners 317

Detergents, Laundry 317

Dish Detergents 316

Disinfectants 314, 318, 759

Floor Cleaners 310-311

Floor Finishes 311

Floor Sealers 311

Floor Stripper 311

Glass Cleaners 315

Hand Cleaners, Lotion 315

Industrial Cleaners, Multi-Purpose 312

Soap Dispensers 315

SAFECROSS

Ammonia Inhalants 734

Antiseptics and Ointments 748

Body Lotions 749

Butterfly Wound Closures 742

Coagulants 761

Compresses 729-732, 734-735, 743, 750

Cotton Tip Applicators 729, 732, 747

CPR

Masks 729-730, 762

Shields 729-735, 762

Disposable Gloves 729-735, 762

Elastic Bandages 731, 740

Fabric Bandages 734, 740

Footwear Odour Neutralizers 750

Forceps 751

Gauze Bandages 729-735, 743

Hydrogen Peroxide 748

Insect Sting Relief 749

Isopropyl Rubbing Alcohol 748

Kits

Burn Care 753

First Aid 729-739

Literature, First Aid 729-730, 732-734

Ointments, Burn Care 749

Plastic Bandages 729-735, 741

Provioidine® Solution 748

Splints 731, 734, 754

Support Bandages 731-732, 746

Tongue Depressors 734, 747

Triangular Bandages 729-735, 747

Tweezers, First Aid 751

SAFETY SUPPORTS INC.

Automotive Stands 209

Work Stands 209

SAFETY WHIPS

Flagstaffs 856

SALISBURY BY HONEYWELL

Arc Flash Clothing

Coats 556

Coveralls 556

Hoods 556-557

Overalls 556

Arc Flash Clothing Kits 556-557

Faceshields 557

Gloves, High Voltage 558-559

SAMUEL ACME

Buckles

Plastic 1421

Stainless Steel 1420

Edge Protectors 1421, 1423

Strapping

Machines & Tools 1420-1421

Poly 1421-1422

Stainless Steel 1420

SANFORD CANADA

Monitor Stands 1577

SANITAIRE BY ELECTROLUX

Vacuums, Upright 360

SCEPTER

Containers, Poly 671

Jerry Cans 671-672

Transfer Pumps 671

BRAND INDEX

SCRUBS

Wipes.....334, 338

SEBA

Flashlights, Rechargeable.....1518
Floodlights.....1526
Hand Lamps.....1526

SHARPIE

Liquid Tip Markers.....846, 1445, 1578
Permanent Markers.....1445, 1578

SHIELD FOR FIRST AID

Blankets, Burn Care.....753
Kits, Burn Care.....753
Lip Balm.....335, 384
Sunscreen.....335, 384

SHOCKWATCH

Impact Labels.....1430
Temperature Labels.....1429

SHOP VAC

Air Filters.....359
Dollies, Waste Container.....271
Garbage Cans.....271
Lids, Waste Container.....271
Portable Blowers.....359
Shop Sweepers.....286, 358
Vacuums
Accessories.....357-359, 688
Back Pack.....357
Portable.....358
Wet / Dry.....354-357, 688

SHOWA BEST GLOVE

Chemical Resistant Gloves.....584, 586-587, 590, 592
Coated Gloves.....562, 566-567, 569-570, 572-573, 593
Cut Resistant Gloves.....575-576, 578, 581
Disposable Gloves.....595, 597, 599
Heat Resistant Gloves.....624

SHURLITE

Flint Lighters.....1073
Flints.....1073

SIGNATURE FENCING

Barricades, Traffic Control.....309, 867

SKETS SAFE

Insect Repellent.....335, 384

SKY HOOK

Sky Hooks.....199

SLICE

Blades, Packaging Knife.....1441
Utility Knives.....1441

SLIDE SLEDGE

Slide Hammers.....1365

SOPER'S

Blankets, Fire Resistant.....656

SOUTHWORTH

Lift Tables.....179, 181
Pallet Lifters.....181

SPAENAUR

Flux.....1145

SPG STORAGE PRODUCT GROUP

Reel Racks.....78
Shelving Units, Steel.....78

SPIC N SPAN

Floor Cleaners.....310

SPRAYON

Aerosol Can Disposal Systems.....1037
Anti-Spatter.....1147
Anti-Static Cleaners.....1007
Brake Cleaners.....1005
CFC Free Degreasers.....319, 1003, 1007
Coil Cleaner.....1005
Contact Cleaners.....1007
Dry Lubricants, Synthetic.....1009, 1012
Dusters, Aerosol.....319, 1007
Flash Free Degreasers.....1007
Food Grade Cleaners, Non-Flammable.....1004
Food Grade Degreasers.....1004, 1007
Galvanizing Compounds.....1146-1147
Glass Cleaners.....315, 1004
Graffiti Removers.....319, 1005, 1043
Industrial Cleaners, Multi-Purpose.....319, 1004
Layout Fluids.....1148
Machinery Oil.....1011
Penetrants, Multi-Purpose.....1013
Rust Converters.....1148
Spray Lubricants.....1008-1012, 1018
Stainless Steel Cleaners.....319, 1004
Stencil Inks.....799

SQWINCHER

Sqwincher®.....648-649
Water Coolers.....650

STACKBIN

Bins, Steel.....40-41
Stacking Bins.....40-41
Stacking Racks.....41

STAEDTLER

Pencils.....1578
Permanent Markers.....1578

STANLEY BOSTITCH

Carton Staplers.....1447
Staple Removers, Packaging.....1447
Staples, Carton Staplers.....1447

STANPRO

Bay Lights.....1520
Fixtures, Light.....1520
Floodlights.....1520

STEINEL CANADA INC.

Heat Guns.....1191

STI

Fire Protection, Fire Alarm Protectors.....654
Key Boxes.....654

STORCAN

Conveyors.....224-225

STOREX

Filing Boxes.....1564

STREAMLIGHT

Batteries, C Cell.....1515
Battery Chargers.....1515
Flashlights
12 V.....1513
AA Cell.....1512-1513, 1515
AAA Cell.....1512
C Cell.....1512-1513
Hazardous Locations.....1513
N.....1513
Pocket.....1512, 1515
Rechargeable.....1513, 1515-1516, 1518
Tactical.....1512
Waterproof.....1513
Headlights, Hard Hat.....419
Lanterns
Cordless.....1516
Waterproof.....1518
Penlights.....1512
Spot Lights.....1516

STRIKE FIRST CORPORATION

Extinguishers, Fire.....651

STRONG HOLD

Cabinets, Storage.....99, 101-102
Shelving Units, Stainless Steel.....99
Shop Desks.....102
Shop Tables.....102

STRONGARM

Auto Body Repair Kits.....208
Automotive Stands.....207
Axle Jacks.....206, 208
Dollies
Mechanic's.....209
Wheel.....208
Engine Stands.....208
Garage Jacks.....206

SUMNER

Jacks, Pipe.....1115
Pipe Flange Aligners.....1115
Pipefitting Levels.....1115

SUNBEAM

Air Filters.....1500
Air Purifiers.....1500
Humidifiers.....1500

SUNLIGHT

Dish Detergents.....316

SUNNEX INC

Task Lights.....1523

SWAN

Guns, Garden Hose.....377

SWINGLINE

Shredders, Paper.....1580

SYNETIK

Ergonomic Products, Seating.....	1554
Office Seating.....	1553
Task Seating.....	209, 1134, 1553

TANITA

Weighing Scales.....	1492
----------------------	------

TECHSTAR PLASTICS INC

Box Trucks.....	173-175
Casters.....	171
Food Handling Containers.....	175
Hoppers, Self-Dumping.....	171
Nesting Bins.....	18
Pallets, Plastic.....	48
Recycling Containers.....	278-279
Salt & Sand Containers.....	363
Stepstands, Steel.....	136
Tanks, Storage.....	27

TENSATOR

Cones, Traffic Control.....	863
Frames, Crowd Control.....	880
Posts, Crowd Control.....	876-879
Rope, Crowd Control.....	879
Rope Ends, Crowd Control.....	879
Security, Gates.....	878
Wall Plates, Crowd Control.....	877

THE ANDERSEN COMPANY

Anti-Fatigue Matting.....	902-903, 905
Entrance Matting	
Pile.....	888
Rubber.....	888

THE HARRIS PRODUCTS GROUP

Cable Connectors, Welding.....	1084
Cutting Attachments, Welding.....	1065
Cutting Tips.....	1065
Cutting Torches.....	1065
Fillet Gauges.....	1073
Flux.....	1141
MIG Pliers.....	1088
Outfits, Welding.....	1062
Regulators, Welding.....	1066
Torch Handles.....	1065

THE SAFETY ZONE

Aprons.....	529-531
Boot Covers.....	527
Hair Nets.....	526-527
Hoods, General Protection.....	527
Lab Coats, General Protection.....	531
Shoe Covers.....	527
Sleeves	
Polypropylene.....	528
Vinyl.....	528

THERMO-HEAT

High Visibility Clothing, Hat/Toque.....	549
--	-----

THERMOID

Acetylene Hoses, Welding.....	1075
Gas Hoses, Welding.....	1075
Oxygen Hoses, Welding.....	1075

TILLSON BRANDS

Salt & Sand Containers.....	363
Scoops, Polyethylene.....	363

TILTWATCH

Handling Labels.....	1430
----------------------	------

TOPRING

Adjusting Valves.....	1232
Chucks, Air.....	1224
Cut-Off Tools, Air.....	1256
Desiccant Systems.....	1251, 1257
Drains, Air.....	1257
Filter/Regulator/Coalescing Filters.....	1257-1258, 1260
Filter/Regulator/Lubricators.....	1255, 1258-1259
Filter/Regulators	1255-1256, 1259
Guns	
Air.....	1225-1227, 1230
Sandblasting.....	1225
Hose Fittings.....	1234, 1247, 1250
Hose Reels.....	1234-1235
Hose Whips.....	1250
Hoses, Air.....	1234
In-Line Filters.....	1251, 1256
In-Line Lubricators.....	1251, 1256, 1261
In-Line Regulators.....	1232, 1256, 1261
Manifolds, Air.....	1250
Non-Sparking Tools, Wrenches.....	1256
Pneumatic Pipe Fittings.....	1247
Pneumatic Tube Fittings.....	1248
Pressure Gauges, Tire.....	1224
Quick Couplers.....	1246, 1248-1250
Tire Inflator Gauges.....	1224
Tire Pressure Gauges.....	1224
Vacuums, Accessories.....	1225
Valves, Safety.....	1232, 1257

TORK

Hand Towels.....	341
Paper Towel Dispensers.....	341-343
Paper Towels.....	341-344, 346
Toilet Paper.....	346
Toilet Paper Dispensers.....	346-347
Wipes.....	339
Wipes Dispensers.....	339

TRACTEL

Hoists, Manual.....	199
---------------------	-----

TRAMEX

Moisture Meters.....	1477
----------------------	------

TREND-PAK

Postal Tubes.....	1434
-------------------	------

TRI LITE MARS

Dock Lights	
Double Strut.....	219
Flexible.....	218-219
Incandescent.....	219
Single Strut.....	219
Stop & Go.....	220
Halogen Lamps / Light Bulbs.....	219
LED Lamps / Light Bulbs.....	219

TRI-ARC MANUFACTURING

Rolling Ladders.....	138-140
----------------------	---------

TRI-FLOW

Spray Lubricants.....	1008, 1010
-----------------------	------------

TRIPP LITE

Power Strips, GFCI.....	1542
UPS Systems.....	1542

TRUE TEMPER

Wheelbarrows.....	370
-------------------	-----

TRUMETER

Measuring Counters.....	1484
Measuring Wheels.....	1278, 1482, 1484
Ratchet Counters.....	1483

TUFF TIE

Cable Ties.....	1435
-----------------	------

TYDEN BROOKS

Tamper Seals.....	1451
-------------------	------

TYROLIT

Cut-Off Wheels.....	912, 914
Flap Discs.....	919
Grinding Wheels, Type 27.....	912, 916

ULTRATECH

Berms, Spill Control.....	681
Cable Protectors, Office.....	218
Drain Protectors.....	682
Drain Seals.....	681-682
Drum Equipment, Spill Pallets.....	704-705, 710
Shovels, Spill Control.....	686

UNION BUTTERFIELD

Countersinks.....	962
Hand Taps.....	956-957
Screw Extractors.....	960
Tap Wrenches.....	960

UNIROPE

Slings, Nylon.....	188
--------------------	-----

URBAN IMAGES

Salt & Sand Containers.....	363
-----------------------------	-----

UTICA

Torque Screwdrivers.....	1329
--------------------------	------

UVEX BY HONEYWELL

Faceshields.....	411
Glasses, Safety.....	391-396
Goggles, Safety.....	404-406, 1120
Solutions, Lens Cleaning.....	409
Stations, Lens Cleaning.....	409
Tissues, Lens Cleaning.....	409

VALLEYCRAFT

Dollies, Drum.....	244, 702
Lifters, Drum.....	238
Pallets, Plastic.....	46
Shelf Carts.....	161
Workbenches, Folding.....	121

VENREZ

Stacking Chairs.....	1555
----------------------	------

VERTEX STANDARD

Two-Way Radios.....	442
---------------------	-----

BRAND INDEX

VESTIL

Agricultural Jacks.....	207
Bollards.....	87
Dollies	
Drum.....	244
Mechanic's.....	209
Polyethylene.....	177
Wheel.....	177
Extensions, Forklift.....	187
Lift Tables.....	178, 181
Lifters, Drum.....	242-243
Machinery Rollers.....	205
Openers, Pail.....	250
Pallet Trucks.....	186
Pallets, Aluminum.....	48
Pry Dollies.....	177
Security, Gates.....	216
Shelving Units, Stainless Steel.....	78
Stairway Ladders.....	140
Sweepers.....	286
Wire Spool Carts.....	167
Work Positioners.....	181

VIBRASYSTEMS

Anti-Vibration Pads.....	1272
Cupmounts.....	1272
Isolators, Vibration.....	1272
Leveling Mounts.....	1272

VIKING

Flame Resistant Clothing, Rainwear.....	542, 548
Flame Retardant Clothing, Jackets.....	542, 548
High Visibility Clothing	
Jackets.....	547-548
Pants.....	548
Parkas.....	547
Sweatshirts.....	547
T-Shirts.....	547
Vests.....	546-547
Hoods, Rain.....	542, 548
Jackets, Rain.....	542, 551
Overalls, Rain.....	542
Pants, Rain.....	551-552
Parkas.....	552
Seat Cover, Automotive.....	546
Vests, Traffic Control.....	545-546
Work Boots.....	633

WAGNER

Guns, Air.....	1051
Sprayers, Paint.....	1051

WALTER SURFACE TECHNOLOGIES

Anti-Spatter.....	1147
Cutting Fluids	
for all Metals.....	1148-1149
for Steel.....	1148
Degreasers, Multi-Purpose.....	319, 1003
Food Grade Degreasers.....	1004

WATERLOO

Tool Storage	
Boxes.....	1394
Cabinets.....	1395
Chests.....	1394-1395

WD-40

3-in-1.....	1012
Dry Lubricants, Silicone.....	1010
Engine Degreasers.....	1015
Spray Lubricants.....	1011, 1018
WD-40®.....	1004, 1013

WEARWELL

Anti-Fatigue Matting.....	891-894, 896-897, 899-900, 905, 907
Anti-Static Matting.....	560, 903-904
Entrance Matting	
Rubber.....	888
Vinyl.....	901
Eyewash Stations, Matting.....	727, 893
Grounding Mats.....	904
Matting, Welding.....	904, 1119

WELD-AID

Anti-Spatter.....	1143
-------------------	------

WELDCOTE METALS

Brazing Alloys.....	1139
Flux.....	1141
MIG Wire	
Bronze.....	1138
Copper.....	1138
Steel.....	1135, 1137
Plasma Cutter Guides.....	1069
Solder.....	1140
Stick Electrodes.....	1136-1137, 1139
TIG Rods.....	1136-1138, 1140

WELDCRAFT

Air (Gas) Cooled Torches.....	1101
Alumina Nozzles.....	1104-1106
Back Caps, TIG Torch.....	1108
Collet Bodies, TIG Torch.....	1107-1109
Collets, TIG Torch.....	1105-1109
Gas Hoses, Welding.....	1110
Insulators, TIG Torch.....	1108
Lava Nozzles.....	1105
Power Cable Adapters, TIG Torch.....	1109
Power Cables, TIG Torch.....	1110
Water Cooled Torches.....	1103-1105
Water Hoses, Welding.....	1110

WELD-MATE

Air (Gas) Cooled Torches.....	1101
Alumina Nozzles.....	1106
Aprons, Leather.....	1132
Back Caps, TIG Torch.....	1108
Beanies, Welding.....	1133
Bibs, Leather.....	1132
Blankets, Welding.....	1118
Cable Connectors, Welding.....	1084-1085
Cable Lugs, Welding.....	1085
Cable Protectors, Welding.....	1110
Casters.....	1119
Chaps, Welding.....	1132
Chipping Hammers, Welding.....	1087
Collet Bodies, TIG Torch.....	1107-1108
Collets, TIG Torch.....	1107
Conductor Tubes, MIG Gun.....	1096
Contact Tips, MIG Gun.....	1094-1097
Cutting Tips.....	1070-1071
Diffusers, MIG Gun.....	1095-1097
Electrode Holders.....	1084
Flint Lighters.....	1073
Flints.....	1073
Gas Hoses, Welding.....	1110
Gloves, Welding.....	619-621, 1129-1131
Goggles, Welding.....	1120
Gouging Electrodes.....	1087
Gouging Torches.....	1087
Ground Clamps, Welding.....	1086
Hand Pads.....	621, 1131
Head Assemblies, MIG Gun.....	1095
Helmets, Welding.....	1123
Insulators, TIG Torch.....	1108
Jackets, Leather.....	1132
Lava Nozzles.....	1105
Liners, MIG Gun.....	1095-1097

Magnifier Plates.....	1128
MIG Guns.....	1094-1096
MIG Pliers.....	1088
MIG Wire, Steel.....	1135
Nozzle Reamers.....	1088
Nozzles, MIG Gun.....	1095-1097
O-Rings, MIG Gun.....	1095
Power Cable Adapters, TIG Torch.....	1109
Power Cables, TIG Torch.....	1110
Pressure Gauges, Dry.....	1068
Retaining Rings, MIG Gun.....	1095
Rod / Electrode Containers.....	1089, 1134
Scratch Brushes.....	947, 1087
Screens, Welding.....	1119
Sleeves, Welding.....	1132
Soapstone.....	1143
Spats, Welding.....	1132
Squares, Welding.....	1086
Sweatbands.....	420, 1133
Tip Cleaners.....	1073
Tip Refacers.....	1073
Triggers, MIG Gun.....	1095
Water Cooled Torches.....	1103
Water Hoses, Welding.....	1110

WELLER

Butane Torches.....	1080
Soldering Guns.....	1080-1082
Soldering Irons.....	1080-1082
Soldering Stations.....	1082

WESCO

Extensions, Forklift.....	242
Gauges, Drum.....	251
Hand Trucks.....	149-151
Lift Tables.....	179, 184
Lifters, Drum.....	238-239, 242-243
Pallet Lifters.....	184
Pallet Trucks.....	185-186
Stackers.....	180
Trucks, Drum.....	247

WESTCOTT

Clipboards.....	1579
-----------------	------

WESTERN ENTERPRISES

Flashback Arrestors.....	1074
Hose Repair Kits, Welding.....	1075
Propane Torches.....	1064
Quick-Connects, Welding.....	1074
Y Connections, Hose.....	1074

WHITE LIGHTNING

Caulk.....	1025
Sealants, Silicone.....	1025

WILTON

Angle Vises.....	1295
Bar Clamps.....	1287
Bench Vises.....	1294
C-Clamps.....	1289
Drill Press Vises.....	1295
Machine Vises.....	1295
Quick Clamps.....	1288
Tilting Vises.....	1295

WINDEX

Glass Cleaners.....	315
---------------------	-----

WIPECO

Paint Supplies	
Accessories.....	1054
Cloths.....	1054
Drop Sheets.....	1054
Rags.....	338, 1054

WISS

Fabric Shears.....	1357
Hand Crimpers, HVAC.....	1359
Hand Seamers, HVAC.....	1359
Nippers, End Cut.....	1357
Scissors	
Electrician.....	1357
General Purpose.....	1356
Industrial.....	1356-1357
Shears, Industrial.....	1356
Snips	
All Purpose.....	1357-1359
Duckbill.....	1357
Grape & Orchard.....	1357
Metal Cutting.....	1358-1359

WMH TOOL GROUP INC.

Bar Clamps.....	1284
------------------------	------

WOBBLELIGHT

Task Lights.....	1529
-------------------------	------

WOODHEAD CANADA LTD

Tool Balancers.....	203
----------------------------	-----

WORKSMAN

Tricycles.....	161
-----------------------	-----

WORLD DRYER

Hand Dryers.....	351
-------------------------	-----

ZENITH SAFETY PRODUCTS

Absorbents.....	684-685, 691-692
Anti-Fatigue Matting.....	894, 902
Anti-Skid Tape.....	872
Anti-slip Snow Shoes.....	636
Aprons.....	530, 533
Arm / Leg Bands, Traffic Control.....	548
Back Supports.....	641

Barricade Tape.....	868
Barricades, Traffic Control.....	83, 867, 874
Bars, Traffic Cone.....	863
Base, Crowd Control.....	874
Battery Acid Neutralizers.....	686
Blankets, Fire Resistant.....	656
Booms, Spill Control.....	679
Boot Sanitizer.....	907
Chemical Resistant Gloves.....	583-584, 586-588, 590-592
Circular Saws, Framing.....	872
Clean Room Matting.....	907
Cleats.....	872
Coated Gloves.....	562-568, 570-574, 578, 591-592, 627-628
Cones, Traffic Control.....	862
Convex Mirrors.....	882
Coveralls, General Protection.....	532-533, 689-693, 697
Cut Resistant Gloves.....	575, 613
Delineators, Traffic Control.....	863
Disposable Dust Masks.....	447
Disposable Gloves.....	594-595, 597-600
Disposable Respirators.....	447
Dollies, Drum.....	244, 702
Dome Mirrors.....	881, 883
Drain Protectors.....	682
Drain Seals.....	682
Drip Pans.....	252, 680
Entrance Matting	
Rubber.....	888
Vinyl.....	901
Ergonomic Products, Gloves.....	601
Face Mask.....	447
Flame Resistant Clothing, Rainwear.....	541
Flat Mirrors.....	882
Folding Gates.....	83, 309, 867
Foot Guards	
Plastic.....	637
Steel.....	637
Glasses	
Cases.....	407
Cord Retainers.....	408
Safety.....	386-390
Gloves	
Canvas Cotton.....	628
Cotton.....	612
Goggles, Safety.....	404, 412, 689-697
Hair Nets.....	526
Hard Hats.....	418
Harnesses, Traffic Control.....	548
Hazardous Materials Cabinets.....	658
Heat Resistant Gloves.....	623-624
High Visibility Clothing	
T-Shirts.....	547
Vests.....	545
Inspection Gloves.....	625

Jersey Gloves.....	628-629
Kits, Spill Control.....	689-698
Knit Gloves.....	626
Lab Coats, General Protection.....	532-533
Leather Gloves.....	608-613, 618
Megaphones.....	444
Neutralizers, Spill Control.....	686, 697
Pads, Spill Control.....	673-678, 680
Parking Curbs, Traffic Control.....	861
Pillows, Spill Control.....	680
Posts, Crowd Control.....	874-875
Rag Rugs, Spill Control.....	679
Rolls, Spill Control.....	673-678, 689-690
Scoops, Polypropylene.....	694
Shoe Covers.....	527
Sleeves	
Cotton.....	528
Vinyl.....	528
Socks, Spill Control.....	680
Solutions, Lens Cleaning.....	409
Speed Bumps, Traffic Control.....	860
Stations, Lens Cleaning.....	409
Suits, Rain.....	540
Toe Guards.....	637
Towellettes, Lens Cleaning.....	409, 465, 760
Vests, Traffic Control.....	545
Waiter's / Parade Gloves.....	625
Wall Plates, Crowd Control.....	875
Winter Lined Gloves.....	549, 571, 609, 611, 613-618
Winter Liners.....	418, 553

ZIPWALL

Paint Supplies	
Wall Barriers.....	1054

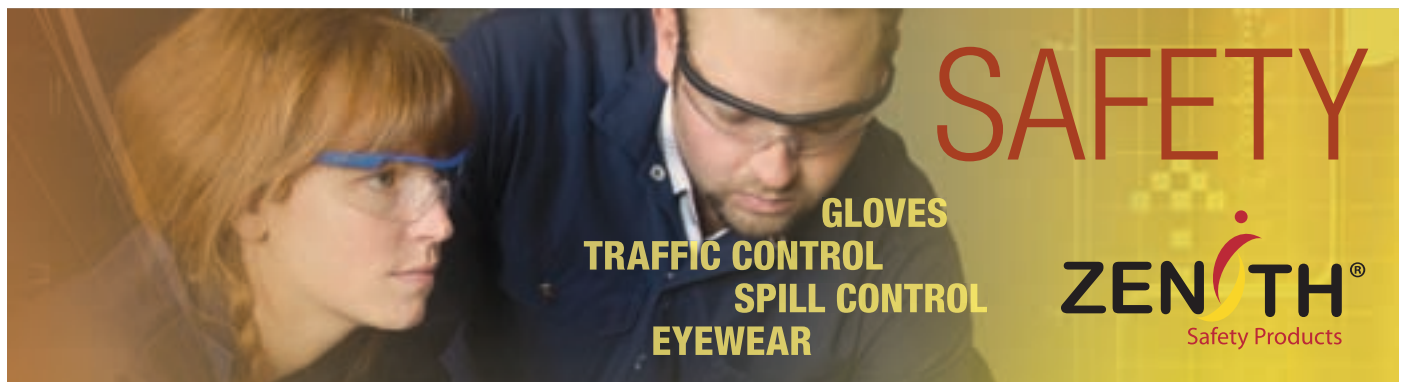

-A-

Abrasives

Backing Pads.....	921-922, 925, 927, 935
Benchstand Belts.....	929
Bristle Brushes.....	921, 1271
Bristle Discs.....	921
Buffing Compounds.....	937
Buffing Wheels.....	937
Cartridge Rolls.....	929
Crimped Filament Wheels.....	912-913
Cup Brushes.....	945
Cut & Polish Wheels.....	938
Cut-Off Wheels.....	912-916
Deburring Wheels.....	936, 938, 1271
Disc Holder Pads.....	922-925, 927, 935-936, 938
End Brushes.....	940, 942, 944
Files.....	1302-1307
Finishing Wheels.....	938
Flap Brushes.....	937
Flap Discs.....	918-919
Flap Wheels.....	919-920, 937
Grinding Wheels.....	912-917, 1271
Grip-On Discs.....	926
Portable Belts.....	928
Portable File Belts.....	928
Rasps.....	1305
Resin Fibre Discs.....	922-923, 925
Rolo™ / Power-Lock Discs.....	924-925, 935
Sanding Sponges.....	933
Sandpaper.....	930-932
Scratch Brushes.....	946-947, 1087
Spiral Bands.....	929
Stick-On Discs.....	926-927
Surface Conditioning Belts.....	937
Surface Conditioning Discs.....	934-936, 938
Surface Conditioning Pads.....	302, 933-934, 938
Surface Conditioning Rolls.....	930, 933-934
Tube Brushes.....	945
Wheel Brushes.....	941-944, 1271
Absorbents	684-685, 691-692
Accelerators, Adhesive	1032
Accident Prevention Tags	786-788, 790
Acetaminophen	752
Acetone	1037
Acetylene Hoses, Welding	1075
Acrylic Coating	1040, 1042-1044
Acrylic Paint	1040, 1042-1044
Adapters, Power Cable	1109
Adaptors, Pipe Thread	1240
ADF Filters	1121, 1124-1126
Adhesive Bandages	741
Adhesives	
Accelerators.....	1032
Acrylic.....	1034
All Purpose.....	1023
Carpenters' Glue.....	1029
Caulk.....	1025
Caulking Guns.....	1018, 1023-1024, 1035, 1045, 1161
Construction & Floor.....	1029
Contact Cement.....	1029
Epoxies.....	1020-1021, 1023, 1033-1034
Epoxy Applicators.....	1021, 1035
Floor Repair.....	1018-1019, 1045
Floor Sealers.....	1019
Glue Guns.....	1035-1036, 1418
Glue Sticks.....	1036, 1418
Instant.....	1031-1032
Pipe Cements.....	1022
Plumbers' Putty.....	1022
Primers.....	1032
Spray.....	1036, 1418
Spreaders.....	1053
Structural.....	1032-1034
Tape.....	1020, 1415
White Glue.....	1029
Wood Glue.....	1029
Adjustable Reamers	985

Adjustable Wrenches	1309-1312, 1330, 1332
Adjusting Valves	1232
Admittance Signs	803-810, 813
Aerosol Can Disposal Systems	1037
Agricultural Jacks	207-208
Air (Gas) Cooled Torches	1101, 1103-1104
Air Conditioners	1500
Air Filters	359, 1058, 1500, 1506
Air Fresheners	314, 321-322
Air Operated Pumps	258
Air Products	
Adjusting Valves.....	1232
Air Dryers.....	1251, 1257
Ball Valves.....	1231
Butterfly Valves.....	1231
Chucks.....	1224
Compressors.....	1262-1265
Cut-Off Tools.....	1204
Drains.....	1257
Filters.....	1251, 1255-1260
Guns.....	1035, 1051, 1225-1230
Hose Fittings.....	1234, 1239, 1247, 1250
Hose Reel Carts.....	1237
Hose Reels.....	1076, 1234-1237, 1532
Hose Whips.....	1250
Hoses.....	1207, 1233-1235
In-Line Regulators.....	1232, 1256, 1261
Lubricators.....	1251, 1256, 1261
Manifolds.....	1250
Pipe Fittings.....	1228, 1240-1244, 1247
Piping.....	81
Pressure Gauges.....	1058, 1224
Quick Couplers.....	1207, 1233, 1246, 1248-1250
Safety Valves.....	1232, 1257
Tire Inflator Gauges.....	1224
Tube Fittings.....	1239, 1248
Tubing.....	1239
Air Purifiers	1500
Air Quality Monitors	487, 1474
Air Tool Oil	1037, 1261
Air Tools	
Buffers.....	1221
Chippers.....	1088, 1207, 1213
Drills.....	1205, 1209, 1221-1223
Engravers.....	1212, 1223
Grinders.....	1204, 1211-1212, 1215, 1220, 1222-1223
Hammers.....	1213
Sanders.....	1207, 1211-1213, 1216-1221
Saws.....	1214
Scalers.....	1207, 1214
Screwdrivers.....	1207, 1209, 1211, 1222
Shears.....	1214
Wrenches.....	1205-1206, 1208, 1210, 1214, 1222
Aircraft Cables	194
Airport Windsocks	871
Airway Kits	763
Aisle Marking Tape	869-870
Aisle Signs	12, 48
Alarms, Smoke	655
Aligners, Pipe Flange	1115-1116
Aligning Punches	1369
Alkyd Coating	1040-1041, 1043-1044
Alkyd Paint	1040-1041, 1043-1044
Alligator Clips	1460, 1463
Alloys, Brazing	1139
Alumina Nozzles	1104-1106
Aluminized Gloves	624
Aluminum Cleaners	1145
Aluminum Foil	1583
Aluminum Foil Tape	1020, 1415
Ambient Air Pump Respirators	466, 481, 1127
Ammonia Inhalants	734, 763
Anchorage Connectors	516-517, 519
Anchors	
Beam Clamp.....	517
Cross-Arm Strap.....	519, 560
D-Bolt.....	516, 519
Friction Bolt.....	516

Anemometers	
Integral Probe.....	1486-1487
Vane.....	1486
Angle Clamps	1285
Angle Drills	
Air.....	1222
Electric.....	1184
Angle Grinders	
Air.....	1204, 1211, 1215, 1222
Electric.....	916, 1163, 1168-1171
Angle Vises	1295
Angle Wrenches	1335
Angled Brooms	290
Annular Cutters	972, 1193
Antibacterial Soap	324-325, 329, 332
Antibacterial Wipes	318, 465, 759-760
Anti-Fatigue Matting	891-909
Anti-Freeze	1144
Anti-inflammatory	752
Antimicrobial Soap	326
Anti-Seize	1016
Antiseptics	
Benzalkonium Towelettes.....	729-735, 748
Dettol™.....	748
Hydrogen Peroxide.....	734, 748, 759
Isopropyl Rubbing Alcohol.....	748
Provioidine® Solution.....	748
Antiseptics and Ointments	729-732, 745, 748-749
Anti-Skid Cleats	872
Anti-Skid Tape	872-873
Antislip Floor Coating	1045
Anti-Slip Floor Coatings	873, 1019
Antislip Floor Paint	1045
Anti-slip Snow Shoes	636
Anti-Spatter	1143, 1145, 1147
Anti-Static Cleaners	1007
Anti-Static Matting	560, 903-904
Anti-Vibration Gloves	606-607
Anti-Vibration Hammers	1364-1365
Anti-Vibration Pads	1272
Appliance Trucks	150, 1454
Aprons	
Chemical Resistant.....	530-531, 533
General Protection.....	529, 534
Heat Resistant.....	551
Leather.....	1132
Limited Use.....	530-531, 533
Tool.....	1391
Welding.....	1132
Arbor Presses	208
Arbors, Hole Saw	1193, 1198
Arc Flash Clothing	
Coats.....	556
Coveralls.....	554-556
Hoods.....	556-557
Jackets.....	555
Overalls.....	555-556
Pants.....	554
Shirts.....	554
Arc Flash Clothing Kits	556-557
Arc Rated Harness	500, 560
Arc Rated Lanyards	510, 560
Archive, Shelving	57
Arm, Splints	731, 734, 754
Arm / Leg Bands, Traffic Control	548
Arrestors, Welding Torch	1074
Ashtrays	236, 283-285, 383, 657
Audio-Visual Carts	1560-1561
Auger Bits	1199
Augers	
Drain.....	1375
Toilet.....	1375
Auto Body Repair Kits	208
Auto-Ignite Torches	1064
Automatic Brake Winches	195
Automotive	
Carburetor Cleaner.....	1015
Windshield De-Icer.....	1015
Automotive Cleaners	
Diesel Conditioner.....	1015
Automotive Seat Cover	280, 546
Automotive Stands	207, 209

Axes	
All-Purpose.....	368
Carpenter.....	368
Axial Blowers	488-489
Axle Jacks	206, 208
-B-	
Back Caps, TIG Torch	1108
Back Supports	641-642
Backboard, Spinal	755
Backing Pads	921-922, 925, 927, 935
Backpack, Hydration	647
Bag Sealing Tape	1436
Bags	
Garbage.....	278, 280-282, 348-349, 383, 761
Laundry.....	303
Paper.....	1435
Poly.....	1436
Static.....	1435
Tire.....	280
Tool.....	1391-1393, 1464
Balaclavas	553
Balancers, Tool	203
Ball Pein Hammers	
Anti-Vibration.....	1365
Fiberglass Handle.....	1365
Non-Sparking.....	1380
Wood Handle.....	1309-1310, 1312, 1362, 1365
Ball Valve Lockouts	780, 782-784
Ball Valves	1231
Balometers	1488
Bandages	
Adhesive.....	741
Butterfly Wound Closures.....	742
Compresses.....	729-730, 734-735, 743, 746
Elastic.....	731, 740, 746
Fabric.....	734, 740-742, 745
Gauze.....	729-735, 743
Plastic.....	729-735, 741-742, 745
Plastic Strips.....	734, 742
Self-Stick.....	742, 746
Spray.....	742
Support.....	731-732, 746
Transparent.....	741
Triangular.....	729-735, 747
Wound Closures.....	742, 745
Banding Film	1425
Bands	
Hearing.....	430-431
Spiral.....	929
Bandaws	
Metal Cutting.....	1178
Wood Cutting.....	1178
Bankers® Boxes	1564
Banners, Traffic Control	859
Bar, Grab	350
Bar Clamps	1284-1287
Bar Magnets	1298
Bar Racks	53
Barricade Tape	868
Barricades, Traffic Control	83, 309, 867, 874
Bars	
Cargo.....	212, 1457
Crowbars.....	368, 1380
Jack.....	1457
Pinch.....	1367, 1380
Power.....	1541
Pry.....	1309-1312, 1340, 1366-1367, 1380, 1386
Rolling Head.....	1367
Traffic Cone.....	863
Wrecking.....	1366
Base, Crowd Control	874
Basins	731, 734, 751, 758
Baskets, Dipping	992
Bathroom Faucets	350
Bathroom Mirrors	350
Baths, Eye	728, 734

Baton Light858, 860	Drill948-955, 963-972,1193, 1196, 1198-1199	Boxes	Bushings, Pipe Thread1240, 1243
Batteries	Forstner1199-1200	Corrugated Paper1431	Butane Torches1080, 1083
1.5 Volt.....1507	Hammer1195-1196	Filing.....1564	Butterfly Valve Lockouts783
12 Volt.....1507, 1522	Hex1344	Jobsite.....36, 1394, 1401-1407	Butterfly Valves1231
3 Volt.....1507, 1515	Hex Square Drives1340, 1343	Key.....654	Butterfly Wound Closures742
6 Volt.....223, 1470, 1507, 1517, 1522	Nutsetters1343	Mailboxes.....1576	
9 Volt.....655, 1507	Posidriv®1345	Mailers.....1434	
AA Cell.....419, 444, 1507,1509, 1511-1512, 1514-1519,1529, 1572-1574	Prentice969-970	MSDS.....667	
AAA Cell.....1507, 1509-1510, 1519, 1572	Rotary Hammer1195	Outlet.....1539	
C Cell.....444, 1507, 1515-1516, 1518	Slotted1344-1345	Suggestion.....1581	
Cordless Power Tools.....1156-1164, 1167	Square Recess1344-1345	Tool Storage.....1309-1311, 1393-1394	
D Cell.....866, 1507, 1509-1510, 1517-1518	Torque1343	Braces, Tennis Elbow643	
Battery Acid Neutralizers686, 1037	Torx®1343-1344	Brackets, Gas Cylinder1079	
Battery Chargers1167, 1507, 1515	Tri-Wing1344	Brake Cleaners1005, 1015	
Cordless Drill.....1167	Blacksmiths' Hammers1366	Brakes, Caster231	
Flashlight.....1515	Blade Disposal Case1438	Brass Hammers1365	
Battery Cleaners1015	Blades	Brass Tags793	
Battery Coolant Checkers1490	Circular Saw.....914, 1202-1203	Brazing Alloys1139	
Battery Equalizers1037	Combination Saw.....1203	Brazing Tips1064	
Bay Lights1520	Cut-Off.....1203	Breaker Hammers1187	
Beaded Chain794	Mitre Saw.....1203	Brick Hammers1364	
Beam Clamp Anchors517	Packaging Knife.....1425, 1430, 1434, 1438-1442	Bristle Brushes921, 1271	
Beam Clamps199, 519	Razor.....1052	Bristle Discs921	
Beam Trolleys190, 519	Reciprocating Saw.....1201	Broadcast Spreaders364, 370	
Beams, Decking & Shoring212, 1457	Blank Tags791-793, 1448	Broom & Mop Racks286	
Beanies, Welding1125, 1133	Blankets	Brooms	
Bearing Greases1017	Burn Care.....753	Angled.....290	
Belt Dressing1012	Emergency.....756	Corn.....289-290	
Belt Holsters, Flashlight1509-1511	Fire Resistant.....656, 753	Magnetic.....290	
Belt Sanders	First Aid.....729, 732, 756-757	Push.....287-290, 301	
Air.....1213, 1216-1217, 1220-1221	Moving.....1454	Spill Control.....687	
Electric.....1180	Welding.....1118	Switch.....290	
Belts	Blast Cabinets1056-1057	Water.....377	
Benchstand.....929	Bleach314	Brushes	
Portable.....928	Blood Pressure Monitors756	Acid.....1141, 1145	
Portable File.....928	Blow Guns1225-1227, 1230	Boot & Shoe.....291, 889	
Surface Conditioning.....937	Blowers	Bristle.....921, 1271	
Tool.....1389	Axial.....488-489	Cup.....945	
Bench Cans992	Centrifugal.....489	End.....940, 942, 944	
Bench Grinders917, 1270	Portable.....359, 488, 1059-1060	Flap.....937	
Bench Scales1433, 1491-1495	Boards, Directory1569	Fountain.....799	
Bench Vises1293-1294	Body Lotions749	Maintenance.....26, 300-301, 1383, 1386	
Benches	Bollards54, 85, 87, 865	Paint.....1046	
Locker Room.....108, 382	Bolt Cutters1360-1361	Parts Cleaning.....993	
Packaging.....1433	Bolt Holder Pliers1349	Pot.....26, 301	
Park.....380	Bolt Removal Penetrants1013	Scratch.....946-947, 1087	
Service.....123-125	Bolts	Scrub.....26, 291, 300, 946	
Shipping.....1433	Carriage.....85, 89	Snow.....364	
Work.....103, 112-117, 120-123, 125, 1432	Eye.....194	Toilet Bowl.....349	
Benchstand Belts929	Bonding & Grounding Wires252-253, 665	Tube.....945	
Benzalkonium Towelettes729-735, 748	Bookcases1567	Vehicle.....292	
Berms, Spill Control681, 711-712, 714	Booms	Wheel.....941-944, 1271	
Bevels1280-1281	Jib.....201	Whitewash.....292	
Bibs	Spill Control.....679	Window.....292	
Leather.....1132	Booster Cables1542	Bubble Mailers1435	
Welding.....1132	Boot, Decontamination907	Bubble Pouches1435	
Bicycle Racks379	Boot & Shoe Cleaners889	Bubble Wrap1427	
Bi-Metal Thermometers1473	Boot Brushes291, 889	Buckets305-307	
Bin Carts7-8	Boot Covers289, 527, 534, 632, 889	Buckles	
Bin Racks8-9, 11, 39, 121	Boot Sanitizer907	Plastic.....1421-1422	
Bin Shelves6, 11, 15-17, 21, 59-60	Boot Trays889	Poly.....1422	
Bin Support Panels7	Boots	Stainless Steel.....1420	
Binders1579	Chemical Resistant.....631	Steel.....1421	
MSDS.....849	Knee.....631-632	Buffers, Air1221	
SDS.....849	Waders.....633	Buffing Compounds937	
Bins	Winter.....635-636	Buffing Wheels937	
ESD.....25	Work.....632-633	Bump Caps415, 417	
Mobile.....6	Borescope, Inspection Cameras1485	Bump Guard, Forklift186	
Nesting.....18-19, 26	Bottle Jacks206	Bumpers, Dock213	
Revolving.....29	Bottles	Bung Wrenches250	
Shelf.....13-15, 25	Dispenser.....672	Bungee Cords1455, 1457	
Small Parts.....11, 25, 31, 39	Storage.....28	Burn Care	
Stacking.....4-6, 13-14, 16-17, 21, 26, 40-41	Box Sealing Tape1410-1411, 1413, 1429	Blankets.....753	
Stacking Container.....4	Box Sealing Tape Dispensers1411, 1429	Creams.....749	
Steel.....40-41, 44-45	Box Trucks166, 172-175	Dressings.....732, 753	
Wire Mesh.....4	Box Wrenches	Gels.....753	
Bit Holders1343	15 Degree Offset.....1336	Kits.....753	
Bits	25 Degree Offset.....1336	Ointments.....749	
Auger.....1199	45 Degree Offset.....1336	Sheets.....753	
Core.....1194	Geared.....1331	Burning Guides1117	
Cross-Point / Phillips®.....1345		Burnishing Pads362	
		Burs, Carbide990-991, 1215	



Cabinet Carts660, 662	Cabinet Drawers37	Cabinet Tables124	Cabinet Tip Screwdrivers1309-1312, 1338-1340, 1383
Cabinets	Acid / Corrosives.....658, 664-666	Computer.....1559-1560	Drum.....663, 665
Extinguisher.....653	Filing.....1562-1563, 1565-1566	First Aid.....739	Flammables.....658, 660-662, 665, 667
Gas Cylinder.....1077	Key.....1570	Paint and Ink.....658, 662-663	Small Parts.....30-34, 37-38, 42-43, 45
Storage.....9-10, 35, 94-103, 381, 1561, 1563	Tool Storage.....103, 1309, 1312, 1395-1400	Cable Connectors, Welding1084-1085	Cable Cutters
Industrial Grade.....1085, 1349-1352, 1361	Insulated.....1377	Cable Lockouts779	Cable Lugs, Welding1085
Cable Protectors	Dock.....217	Office.....218, 1540	Welding.....1110
Cable Tie Tools1452	Cable Ties793-794, 1435, 1452	Cable Tracers1468, 1543	Cables
Aircraft.....194	Booster.....1542	Welding.....1085	Caddies, Table1557
Caddy, Waste Container266	Cafeteria Supplies	Aluminum Foil.....1583	Cling Wrap.....1583
Coffee Equipment.....1583-1584	Coolers.....1586	Cup Dispensers.....1583	Cups.....1583
Forks.....1583	Knives.....1583	Microwave Ovens.....1584	Napkin Dispensers.....343-344, 1583
Napkins.....343-344, 1583	Plates.....1583	Refrigerators.....1584	Spoons.....1583
Stirring Sticks.....1583	Straws.....1583	Table Caddies.....1557	Tables.....382, 1556-1557
Calibration Gas Regulator484-486	Calipers, Digital1275, 1309-1310	Cam & Groove Fittings, Pumps263	Cameras
Inspection.....1376, 1485	Thermal.....1470	Cans	Bench.....992
Drip.....670	Garbage.....169, 266-275, 349-350,383, 761, 1577	Gas.....671-672	Jerry.....671-672
Oil.....999	Oily Waste.....670-671	Plunger.....670	

INDEX

Safety.....	668-669	Office.....	1546, 1548-1549, 1553-1554	Cleaners		Liquid Repellant.....	638, 1045
Step.....	269-270, 761	Stacking.....	1555	Battery.....	1015	Rubber.....	1012, 1015, 1045
Cantilever Racks	52	Task.....	1546, 1551	Degreasers.....	312-315, 319, 1002-1007, 1015, 1036, 1144	Coating Thickness Gauges	1478
Cap Seal Crimpers	250-251	Chalk Lines	1279	Electrical.....	319, 686, 1005-1007, 1015, 1037	Coatings	
Cap Seals, Drum	251	Changing Tables	348	File.....	1037	Anti-Slip.....	873, 1019
Cape Chisels	1368	Channelizers, Traffic Control	864	Hand.....	315, 324-329, 331-332	Anti-Spatter.....	1143, 1145, 1147
Caps		Chaps, Welding	1132	Heavy-Duty.....	1037	Belt Dressing.....	1012
Bump.....	415, 417	Chargers		Industrial.....	310-320, 349, 759-760, 889, 1003-1005, 1014-1015, 1020, 1037, 1043, 1144-1146	Floor.....	311, 362, 873, 1019, 1021
Insulator.....	1098	Batteries.....	1167, 1507, 1515	Laundry Detergents.....	317	Galvanizing Compounds.....	1014, 1144, 1146-1147
Welding.....	1125, 1133	Cordless Drill.....	1167	Lens.....	409, 465, 760	Marking Wands.....	1038-1040
Caps & Plugs, Pipe Thread	1240-1242	Flashlight.....	1515	Welding Tip.....	1073	Paint.....	1040
Carabiners	516, 520	Checklist Kit, Forklift	187	Cleaning Equipment		Rust Converters.....	1014, 1146, 1148
Carbon Monoxide Meters	487	Chemical Hazard Signs	804, 808	Broom & Mop Racks.....	286	Rust Preventers.....	1014, 1146
Carburetor Cleaner	1015	Chemical Resistant Boots	631	Brushes.....	26, 291-292, 300-301, 349, 946, 1383, 1386	Striping Machines.....	1039-1040
Cargo Bars	212, 1457	Chemical Resistant Clothing		Buckets.....	305-307	Wood Fillers.....	1022
Cargo Nets	1455	Aprons.....	530-531, 533	Buckets / Wringers.....	306-307	Coats	
Carpenter Axes	368	Coveralls.....	537-539	Carts.....	275, 309	Arc Flash.....	556
Carpenter Squares	1280	Chemical Resistant Gloves	583-592	Dusters.....	294, 302, 320	Flame Resistant.....	556
Carpenters' Glue	1029	Chest Protectors, Welding	1125	Dustpans.....	290, 296, 687	Heat Resistant.....	551
Carpet Cleaners	317	Chest Waders	633	Mops.....	292-295, 304-306	Winter.....	552
Carriage Bolts	85, 89	Chests, Tool Storage	1309-1310, 1394-1399, 1402-1403	Pads.....	292, 294, 302, 320, 362	Coffee Equipment	1583-1584
Carton Rack	1434	Chippers, Air	1088, 1207, 1213	Pressure Washers.....	374-375	Coil Cleaner	1309-1312, 1367-1368, 1370
Carton Staplers	1446-1447	Chipping Hammers, Welding	1087-1088	Scrubbers.....	292, 302, 320	Cold Chisels	1309-1312, 1367-1368, 1370
Cartridge Rolls	929	Chisel Holders	1367	Squeegees.....	296-299, 301, 687	Cold Compresses	731-732, 734, 750
Cartridges, Respirator	456, 460-464, 466, 470, 472-473, 475, 477, 480	Chisels		Sweepers.....	286, 358	Cold Wire Feed Torches	1091
		Cape.....	1368	Trigger Sprayers.....	302, 320	Cold Wire Feeders, TIG Torch	1091
		Cold.....	1309-1310, 1312, 1367-1368, 1370	Vacuum Cleaners.....	352-361, 688, 1225	Collapsible Containers	44-45
		Hand.....	1194, 1381	Water Brooms.....	377	Collet Bodies, TIG Torch	1107-1109
		Scaling.....	1088, 1194	Window Washers.....	299	Column Protectors	1105-1109
		Woodworking.....	1367	Wringers.....	294, 307	Combination Saw Blades	1203
Carts		Chucks		Cleaning Fluids, Parts Washers	995	Combination Slip-Joint Pliers	1377
Audio-Visual.....	1560-1561	Rail.....	210	Cleats	636, 872	Combination Wrenches	1331-1333
Bin.....	7-8	Wheel.....	210-211	Clevis Grab Hooks	192-193	Sets.....	1309-1310, 1312, 1332, 1334, 1337
Cabinet.....	660, 662	Chop Saws	914, 1174	Cling Wrap	1583	Combined Drills & Countersinks	961
Computer.....	1561	Chucking Reamers		Clipboards	1579	Combo Kits	1164-1166
Drum.....	701	Cobalt.....	985	Clips, Alligator	1460, 1463	Combustible Gas Detectors	487
Drywall.....	159	HSS.....	981-985	Clocks		Communication	
Gas Cylinder.....	1078	Chucks		Time.....	1575	Cell Phone Accessories.....	443
Hose Reel.....	1237	Air.....	1224	Wall.....	1575	Cell Phone Holders.....	443, 1387, 1390
Janitorial.....	275, 309	Drill.....	1268-1269	Close Quarter Drills	1184	Horns.....	221
Ladder.....	134	ER Collet.....	1269	Closures, Drum	234, 251	Megaphones.....	444
Laundry.....	303	Circuit Breaker Extension Cords	1538	Clothes Hooks	350	Signal Horns.....	444
Lumber.....	159-160	Circuit Breaker Lockouts	781-782	Clothing		Two-Way Radios.....	435, 438-439, 441-442
Order Picking.....	165	Circuit Testers	1461, 1539	Arc Flash.....	554-557	Compound Leverage Wrenches	1372
Parts Storage.....	42	Circular Saw Blades	914, 1202-1203	Chemical Resistant.....	530-531, 533, 537-539	Compounds	
Security.....	77	Circular Saws		Flame Resistant.....	645-647	Buffing.....	937
Shelf.....	73, 76-77, 161-165, 167-168, 170	Framing.....	872	Air.....	538, 541-542, 548, 554-557	Retaining.....	1027
Shop.....	7-8, 42, 73, 76-77, 161-170	Heavy-Duty.....	1162, 1177	Electric.....	542, 548	Sweeping.....	290
Stock Picking.....	165	Circular Split Dies	978, 980	General Protection.....	527, 529, 531-539, 689-693, 697	Tapping.....	1149
Tool.....	123-125, 1395, 1397, 1400	Citrus Base Cleaners	319, 1003, 1005, 1036	Hangers.....	1581	Compresses	729-732, 734-735, 743, 746, 750
Trades.....	169	Clamp Meters		Heat Resistant.....	551	Compressors	
Utility.....	76, 166, 168-170	AC / DC.....	1466	High Visibility.....	543, 545-549, 551	Air.....	1262-1265
Welding.....	1078	Current Clamps.....	1461, 1466, 1468, 1540	Limited Use.....	527, 529-539, 689-693, 697	Electric.....	1262-1264
Wire Spool.....	167	True RMS.....	1460, 1466	Rainwear.....	540-543, 548, 551-552	Gas.....	1263-1265
Cases		Clamps		Suspenders.....	1389	Computer Cabinets	1559-1560
Blade Disposal.....	1438	Angle.....	1285	Welding.....	1125, 1132-1133	Computer Carts	1561
Equipment.....	1461, 1464-1465, 1471	Bar.....	1284-1287	Winter.....	552, 555	Computer Desks	1560
Eyewear.....	407	Beam.....	199, 519	Work.....	418, 420, 530-531, 550, 552-554, 1133	Computer Supplies	
Small Parts.....	36	C-Clamps.....	1288-1289	Clothing Kits, Arc Flash	556-557	Grounding Mats.....	904
Casters	137, 152-154, 162-165, 171, 176-177, 227-231, 245-246, 1119, 1433, 1550	Drum Lifting.....	240, 243	Club Hammers	369, 1365-1366	Keyboard Trays.....	1558
		Ear.....	1238	Coagulants	742, 761	Keyboard Wrist Rests.....	1558
Caulk	1025	Edge-Gluing.....	1288	Coat Racks	1581	Monitor Stands.....	1577
Caulking Guns	1018, 1023-1024, 1035, 1045, 1161	Ground - Welding.....	1086	Coated Gloves	562-574, 576-578, 580, 591-593, 627-628	Conditioners	
		Hold-Down.....	1290-1292	Coating		Air.....	1500
Caution Tags	790	Hose.....	1238	Acrylic.....	1040, 1042-1044	Skin.....	333
C-Clamps	1288-1289	Latch.....	1290-1292	Alkyd.....	1040-1041, 1043-1044	Conductivity Meters	1490
Ceiling Fans	1498	L-Clamps.....	1284	Antislip.....	1045	Conductor Tubes, MIG Gun	1096
Ceiling Mounted Heaters	1504	Lifting.....	198	Epoxy.....	1042-1043	Cone Bars	863
Cell Phone		Paper.....	1565	Floor.....	1019, 1044-1045	Cones	
Accessories.....	443	Parallel.....	1286-1287	High Heat.....	1042-1043	Crowd Control.....	296, 308
Holdings.....	443, 1387, 1390	Pipe.....	1285	Hydrophobic.....	638, 1045	Pallet.....	48, 1423
Cements, Pipe	1022	Quick.....	1288	Latex.....	1042	Safety.....	308
Center Punches	1309-1310, 1312, 1368, 1370	Spring.....	1288	Conductivity Meters	1490	Traffic Control.....	862-863
Centrifugal Blowers	489	Straight Line.....	1290, 1292	Conductor Tubes, MIG Gun	1096	Confined Space Lockouts	784
Ceramic Magnets	1299	Toggle.....	1290-1291	Cone Bars	863	Confined Space Signs	758, 804, 808
CFC Free Degreasers	319, 1002-1003, 1007	Claw and Ripping Hammers	1364	Connectors		Anchorage.....	516-517, 519
Chain		Claw Hammers	1362, 1364	Anchorage.....	516-517, 519	Cable.....	1084-1085
Beaded.....	794	Clean Air Solvents	1002	Cable.....	1084-1085	Swivel.....	1219, 1250
Crowd Control.....	794, 880	Clean Room Matting	907	Wire.....	1543		
Lifting.....	193	Cleaner, Carburetor	1015				
Chain Nose Pliers	1348						
Chain Wrenches	1372						
Chains, Key	1570-1571						
Chair Caddies	1554						
Chairs							
Ergonomic.....	1547-1549, 1554						
Folding.....	382, 1554						

Conspicuity Tape850	Couplers, Quick1207, 1233, 1246, 1248-1250	Cut-Off Wheels912-916	Desks
Construction, Vapor Barriers1437	Couplings, Pipe Thread1240-1241, 1243-1244	Cutters	Computer.....1560
Construction Adhesives1029	Coveralls	Annular.....972, 1193	Office.....1567
Construction Tape1437	Arc Flash.....554-556	Bolt.....1360-1361	Shop.....102, 126
Contact Cement1029	Chemical Resistant.....537-539	Cable.....1085, 1349, 1351-1352, 1361, 1377	Detergents, Laundry317
Contact Cleaners1005-1007	Flame Resistant.....538, 554-556	Insulated.....1377	Dettol™.....748
Contact Tips, MIG Gun1094-1098	General Protection.....532-539, 689-693, 697	Iron Shear.....1361	Developers
Container FDA Liners280	Limited Use.....537-539	Paper.....1427, 1432-1433	Non-Aqueous.....1144
Containers	Work.....550, 554	Rebar.....1361	Non-Chlorinated.....1020, 1144
Bottles.....28	Covers	Rotary.....1163	Diagonal Cutters1309-1312, 1348,
Collapsible.....44-45	Boot.....289, 527, 534, 632, 889	Tubing.....13741350, 1353, 1377, 1383
Distribution.....18-20, 22-24, 1564	Drum.....236, 670, 699	Cutting Attachments, Welding1065	Dial Scales1494
ESD.....25	Fire Extinguisher.....653	Cutting Fluids	Diaphragm Pumps258
Food Handling.....175	Pail.....236	for all Metals.....1148-1149	Die Grinders
Jars.....28	Shoe.....289, 527, 889	for Aluminum.....1148	Air.....1204, 1212, 1215, 1220, 1223
Mobile Bins.....6	Toilet Seat.....348	for Steel.....1148	Electric.....1172
Nesting Bins.....18-19, 26	Waste Containers.....266, 268, 271-272, 276-277	Cutting Tips1065, 1070-1072	Dielectric Greases1018
Poly.....27, 234, 671	CPR	Cutting Tools	Dielectric Hasp Lockouts780
Recycling.....276-279, 1577	Kits.....763	Adjustable Reamers.....985	Dies
Revolving Bins.....29	Masks.....729-730, 762-763	Annular Cutters.....972, 1193	Circular Split.....978, 980
Salt & Sand.....363, 689	Shields.....729-735, 762	Auger Bits.....1199	Die Stocks.....977
Shelf Bins.....13-15, 25	Crack Check1012, 1020, 1144, 1148	Burs.....990-991, 1215	Hexagonal.....978-979
Small Parts Bins.....11, 25, 31, 39	Crane Scales203, 1496	Chucking Reamers.....981-985	Diesel Conditioner1015
Spill Control.....709-710	Cranes	Circular Saw Blades.....914, 1202-1203	Diffusers, MIG Gun1095-1098
Stacking Bins.....4-6, 13-14, 16-17, 21, 26, 40-41	Floor.....200, 202	Circular Split Dies.....978, 980	Digital Thermometers1472-1473
Steel Bins.....40-41, 44-45	Gantry.....200	Combination Saw Blades.....1203	Dilution Dispenser313
Tanks.....27	Jib.....201	Combined Drills & Countersinks.....961	Dip Tanks992
Transfer Boxes.....19	Shop.....202, 208	Core Bits.....1194	Dipping Baskets992
Control Valves1000	Truck Mounted.....202	Countersinks.....962	Direction Signs811
Convertible Pliers1353	Crayons	Cut-Off Blades.....1203	Directory Boards1569
Convex Mirrors882	Lumber.....1142, 1444	Die Stocks.....977	Disc Holder Pads922-925, 927, 935-936, 938
Conveyors224-225	Temperature.....1142, 1445	Drill Bits.....948-955, 963-972,	Discharge Hoses263
Cooking Thermometers1471, 1473	Cream Dispensers3311193, 1196, 1198-1199	Discs
Coolant Tanks1150	Creams	End Mills.....986-989	Bristle.....921
Coolers	Burn Care.....749	Forstner Bits.....1199-1200	Flap.....918-919
Containers.....1586	Hand.....331, 333	Hand Reamers.....981	Grip-On.....926
Water.....650	Skin.....333	Hand Taps.....956-960, 974-975, 977, 988	Resin Fibre.....922-923, 925
Cooling Clothing	Crimped Filament Wheels912-913	Hexagonal Dies.....978-979	Roloc™ / Power-Lock.....924-925, 935
Hard Hat Liners.....646	Crimpers	Hole Saws.....1193, 1197-1198	Stick-On.....926-927
Hats.....645	Cap Seal.....250-251	Machine Taps.....976	Surface Conditioning.....934-936, 938
Headbands.....645, 647	HVAC.....1359	Mitre Saw Blades.....1203	Dish Detergents316
Neck Shades.....647	Crimping Die Pliers1349, 1377	Pipe Taps.....960, 973	Disinfectants313-314, 318, 759-760
Towels.....645-646	Cross Check Tamper Proof Indicator1342	Points.....1194	Dispenser Bottles672
Vests.....646-647	Cross-Arm Strap Anchors519, 560	Prentice Drill Bits.....969-970	Dispenser Dilution313
Wraps.....645, 647	Crosses, Pipe Thread1244	Reciprocating Saw Blades.....1201	Dispensers
Copper Hammers1365	Crossover Ladders140	Rotary Hammer Bits.....1195-1196	Aisle Marking Tape.....868
Cord Reels	Cross-Point Bits1345	Screw Extractors.....960, 989	Box Sealing Tape.....1411, 1429
Extension Cords.....1531-1532, 1537	Cross-Point Screwdrivers1309-1312,	Tap & Drill Sets.....973	Cream.....331
Fluorescent.....15321338-1341, 1378, 1383, 1386	Taper Pin Reamers.....982	Cup.....1583
Incandescent.....1531-1532	Crowbars	Tool Holders.....986, 1269	Dust Mask.....453
Quad Box.....1531	Non-Sparking.....1380	Cutting Torches1065	Ear Plug.....427, 431
Single Outlet.....1531-1532	Pitch Point.....368	D Handle Drills1183-1184	Filament Tape.....1411-1413
Triple Outlet.....1532	Crowd Control	Danger Tags790	Gloves.....600
Work Lights.....1531	Base.....874	D-Bolt Anchors516, 519	Gummed Tape.....1411, 1413
Cord Retainers, Eyewear408	Chain.....794, 880	Dead Blow Hammers1309-1312, 1362-1363	Hand Sanitizer.....323-324
Cord Sets, GFCL1539	Cones.....296, 308	Deburring Hand Tools1308	Hand Soap.....315, 324-326, 330-333
Cordless Power Tool Batteries1156-1164, 1167	Rope & Posts.....821, 874-880	Deburring Wheels936, 938, 1271	Napkin.....343-344, 1583
Cordless Screwdrivers1161, 1187	Wall mounted.....875, 877	Decking Beams212, 1457	Paper Towel.....340-343, 1583
Cords	Crutches, First Aid758	Degreasers	Reel.....167
Bungee.....1455, 1457	CSA Standard Signs814-817	CFC Free.....319, 1002-1003, 1007	Sanitary Napkin.....348
Extension.....1535-1538, 1541	Cultivators368	Engine.....1015	Scotch® Tape.....1580
Core Bits1194	Cup Brushes945	Flash Free.....1007	Strapping.....1420, 1422
Coring Motors1189	Cup Dispensers1583	Food Grade.....1003-1004, 1007	Stretch Wrap.....1424-1426
Corkboards1569	Cup Magnets1299	Heavy-Duty.....312-315, 319, 1002-1005, 1036	Toilet Paper.....345-347
Corn Brooms289-290	Cupmounts1272	Multi-Purpose.....312, 319, 1002-1004	Toilet Seat Cover.....348
Corner Protectors48, 86-87, 216, 1421, 1423	Cups	Non-Chlorinated.....1144	Two-Way Tape.....1416
Corrugated Boxes1431	Cafeteria.....1583	Solvent Free.....313, 1002-1003	Wipes.....334, 336, 338-340
Corrugated Pads1431	Measuring.....317, 994	Deheaders, Drum250	Display Hangers, Merchandise1435
Corrugated Paper1430	Vacuum.....196-197	De-Icer1015	Displays, Literature1568
Corvers, Pallet1423	Curtain, Privacy Shower727	Delineators, Traffic Control863-864	Disposable Dust Masks447, 453
Cotton Balls747	Curtains, Strip91-93	Demolition Hammers1187	Disposable Face Mask447
Cotton Tip Applicators729, 732, 747	Curved Blade Knives1382, 1386	Depressors, Tongue734, 747	Disposable Gloves594-600, 656, 729-735, 762
Cough and Cold Relievers752	Curved Claw Hammers1309-1312, 1364, 1380	Desiccant Systems1251, 1257	Disposable Respirators447-453
Counters	Cut & Polish Wheels938	Desiccants1429	Distribution Containers18-20, 22-24, 1564
Measuring.....1484	Cut Resistant Gloves575-581, 613	Desk Lamps1524, 1582	Dock Equipment
Ratchet.....1483	Cut-Off Blades1203	Desk Organizers1577	Bumpers.....213
Tally.....1483	Cut-Off Tools, Air1204		Cable & Hose Protectors.....217
Countersinks962			Dock Risers.....215
Countersinks & Drills, Combined961			Dockboards.....215
Counting Scales1491			Dockplates.....215
			Fenders.....212

-D-

INDEX

Levelers.....	214	Hammer Drill / Driver.....	1157-1159	Dust Masks, Disposable.....	447, 453	Slot Drills.....	986-987
Lights.....	218-220	Hand Powered.....	1182-1183, 1186	Dust Mop Frames.....	293-295, 302	Square End.....	988-989
Pallet Pullers.....	186	Drills & Countersinks, Combined.....	961	Dust Mops.....	293, 295	Supermills.....	987
Rail Chocks.....	210	D-Ring Harnesses.....	495	Dusters.....		Weldon Shank.....	986-987
Twin Ramps.....	214	Drinks, Rehydration.....	648-649	Aerosol.....	319, 1006-1007	End Wrenches.....	1373
Walkramps.....	214	Drip Cans.....	670	Janitorial.....	294, 302, 320	Engine Degreasers.....	1015
Wheel Chocks.....	210-211	Drip Pans.....	252, 680-681	Dustpans.....	290, 296, 687	Engine Stands.....	208
Dock Lights		Drive Pin Punches.....	1369	Dye Penetrants.....	1012, 1020, 1144, 1148	Engine Tilters.....	208
Double Strut.....	219	Drop Sheets.....	1054	Drops, Eye.....		Engine-Powered Pumps.....	264
Flexible.....	218-219	Drum Equipment				Engravers	
Halogen.....	218	Bonding & Grounding Wires.....				Air.....	1212, 1223
Incandescent.....	219	252-253, 665			Dremel.....	1192
Single Strut.....	218-219	Cabinets.....	663, 665	Ear Clamps.....	1238	Entrance Matting	
Stop & Go.....	220	Cap Seals.....	251	Ear Muffs		Carpet.....	886-887
Docking Stations.....	482-483, 485-486	Carts.....	701	Cap Mounted.....	433-439	Eco.....	886
Document Laminators.....	1574	Closures.....	234, 251	Headband.....	433-438, 549	Needle Rib.....	885
Dollies		Covers.....	236, 670, 699	Hygiene Kits.....	435	Pile.....	885-888
Aluminum.....	177	Deheaders.....	250	Neckband.....	434, 436-437	Polypropylene.....	885
Cabinet.....	97, 103	Dollies.....	244, 266, 701-702	Ear Plugs		Rubber.....	886-888, 901, 909
Drum.....	244, 266, 701-702	Faucets.....	251-252	Corded.....	423-426, 428-429	Vinyl.....	901
Gas Cylinder.....	1078	Funnels.....	241, 251, 699	Dispensers.....	427, 431	Wiper.....	874, 885-887
Knee.....	209	Gauges.....	251	Disposable.....	423-427	Envelopes, Packing List.....	1449
Mechanic's.....	209	Heaters.....	237	Reusable.....	426, 428-429	Environmental Cleaners.....	317-318
Pail.....	244	Lids.....	236	Uncorded.....	423-429	Epoxies	
Polyethylene.....	177	Lifters.....	238-243, 701	Ear Protection Signs	806, 809	for Metal.....	1020-1021
Pry.....	177	Liners.....	235	Earloop Face Mask	447	General Purpose.....	1023, 1033-1034
Stacking.....	20	Mixers.....	249	Edge Protectors.....	48, 86-87, 216, 1421, 1423	Mixer Cups.....	1021
Steel Deck.....	97, 103	Pail Heaters.....	237	Edge-Gluing Clamps	1288	Putty.....	1020-1021, 1023
Waste Container.....	266, 271, 276-277	Pail Inserts.....	235	Ejectors, Smoke	1501	Syringe.....	1021
Wheel.....	177, 208	Pail Tipplers.....	245	Elastic Bandages.....	731, 740, 746	Two Part.....	1033
Wood.....	176	Pail Tumblers.....	248	Elbow Protectors.....	643	Epoxy Applicators.....	1021, 1035
Dome Mirrors.....	881, 883	Pails.....	27, 695-696	Elbows, Pipe Thread.....	1240-1244	Epoxy Coating.....	1042-1043
Doors, Curtain.....	91-93	Pallet Servers.....	239	Electrical Cleaners		Epoxy Paint.....	1042-1043
Double Faced Hammers.....	1366	Pumps.....	254-258	Anti-Static.....	1007	Equalizers, Battery.....	1037
Double Sided Tape.....	1416	Racks.....	245, 703	Contact.....	1005-1007	Equipment Cases.....	1461, 1464-1465, 1471
Double Stepladders.....	129-131	Rockers.....	245	Dusters.....	319, 1006-1007	Equipment Stands.....	170
Drain Augers.....	1375	Rotators.....	239, 248	Electrical Gloves.....	558-559	ER Collet Chucks.....	1269
Drain Cleaners.....	316	Spill Pallets.....	704-708, 710, 713-714	Electrical Hazard Signs.....	804-805, 808	Ergonomic Products	
Drain Protectors.....	682	Spotters.....	247	Electrical Plug Lockouts.....	781-782	Back Supports.....	641-642
Drain Seals.....	681-683, 689-693	Stackers.....	242	Electrical Supplies		Elbow Protectors.....	643
Drain Spades.....	366	Strainers.....	235	Alligator Clips.....	1460, 1463	Forearm Protectors.....	643
Drains, Air.....	1257	Tilters.....	239-240, 254	Batteries.....	1507	Gloves.....	601-603, 605
Drawers, Cabinet.....	37	Trays.....	681, 703, 711, 713	Battery Chargers.....	1167, 1507, 1515	Knee Pads.....	639-640, 1133
Dremel Tools.....	1192	Trucks.....	246-247	Booster Cables.....	1542	Kneeling Pads.....	639
Drench Hoses.....	726	Upenders.....	250	Cable Protectors.....	218, 1540	Seating.....	1547-1549, 1554
Dressings		Valves.....	252	Connectors.....	1219, 1250, 1543	Tennis Elbow Braces.....	643
Burn Care.....	732, 753	Vents.....	251	Cord Reels.....	1531-1532, 1537	Wrist Supports.....	643-644, 746
Eye.....	728, 734	Drum Fans.....	1497, 1502	Extension Cords.....	1535-1538, 1541	Escape Ladders.....	656
Drift Punches.....	1309-1310, 1369-1370	Drum Tools		GFCI Products.....	1539-1542	ESD Products, Bins.....	25
Drill Bits		Cap Seal Crimpers.....	250-251	Outlet Boxes.....	1539	Exhaust Fans.....	1501
Aircraft Extension.....	968, 972	Pail Openers.....	250	Plugs.....	1084	Exit Lights.....	1521
Hex Shank.....	1198	Wrenches.....	250	Power Bars.....	1541	Exit Signs.....	807, 810-811, 1521
Jobber.....	948-953, 963-967	Drums		Receptacles.....	1084	Expandable Gates.....	309
Masonry.....	1196	Fibre.....	234	Tape.....	1417, 1544	Extension Cords	
Silver & Deming.....	954	Polyethylene.....	234, 691-695	Circuit Breaker.....	1538	Circuit Breaker.....	1538
Spiral Flute.....	972	Steel.....	234, 236	Double Outlet.....	1541	Double Outlet.....	1541
Spline-Shank.....	1196	Dry Lubricants		Single Outlet.....	1535-1538, 1541	Timers.....	1535-1538, 1541
Straight Shank.....	971	Graphite.....	1008	Triple Outlet.....	1535-1537	Wire Strippers.....	1351
Stub.....	953-954	Silicone.....	1010	Electrical Switch Lockouts.....	781	Electromagnetic Drill Presses.....	1188-1189
Taper Length.....	969	Synthetic.....	1009, 1012	Electrode / Rod Containers.....	1089, 1134	Emergency Blankets.....	756
Taper Shank.....	955, 971	Dryers		Electrode Holders.....	1084	Emergency Escape Respirators.....	459
Through-Hole.....	1199	Air.....	1251, 1257	Electrode Ovens.....	1089	Emergency Lights.....	1521-1522
Two-Piece.....	1193	Hand.....	351	Electrodes		Emergency Showers.....	718-719
Drill Press Vises.....	1295-1296	Drywall Carts.....	159	Gouging.....	1087	Enclosures	
Drill Presses		Drywall Tools		Stick.....	1136-1137, 1139	Fences.....	866
Bench.....	1266-1267	Hand Sanders.....	1053	Tungsten.....	1114	Steel Mesh.....	90
Electromagnetic.....	1188-1189	Hawks.....	1053	Electromagnetic Drill Presses.....	1188-1189	End Brushes.....	940, 942, 944
Floor.....	1266-1267	Knives.....	1052-1053, 1382, 1386	Emergency Blankets.....	756	End Cutters.....	1349
Drilling Machines		Putty Knives.....	1052, 1382, 1386	Emergency Escape Respirators.....	459	End Mills	
Drill Presses.....	1188-1189, 1266-1267	Razor Blades.....	1052	Emergency Lights.....	1521-1522	Ball End.....	988-989
Gearhead.....	1267	Sanding Blocks.....	1053	Emergency Showers.....	718-719	Carbide.....	988-989
Drills		Saws.....	1053	Enclosures		HSS.....	986-987
Air.....	1205, 1209, 1221-1223	Scrapers.....	1052, 1382	Steel Mesh.....	90	HSS.....	986
Angle.....	1184	Spatulas.....	1382	End Brushes.....	940, 942, 944	Long.....	989
Chucks.....	1268-1269	Trowels.....	1053	End Cutters.....	1349		
Close Quarter.....	1184	T-Squares.....	1280	End Mills			
D Handle / Spade Handle.....	1183-1184	Duct Tape.....	1415	Ball End.....	988-989		
Drill / Drivers.....	1182	Dump Trucks.....	172-173	Carbide.....	988-989		
Drill / Drivers - Cordless.....		Durometers.....	1479	HS Co.....	986-987		
.....	1156-1158, 1161, 1164	Dust Collectors, Sandblasting.....	1056	HSS.....	986		
Hammer.....	1158-1159, 1184-1187	Dust Mask Dispensers.....	453	Long.....	989		



Solutions..... 722-725, 728, 734
 Supplemental..... 724-725
 Wall Mounted..... 716, 720
 Water Preservatives..... 722-723, 725

Eyewear
 Cases..... 407
 Cord Retainers..... 408
 Reading Glasses..... 399
 Safety Glasses..... 386-403, 407, 1310-1311
 Safety Goggles..... 404-406, 412, 689-697, 1120
 Welding Goggles..... 1120

-F-

Fabric Bandages..... 734, 740-742, 745
Fabric Shears..... 1357
Face Mask..... 447
Faceshields..... 410-413, 557
Facial Tissue..... 344

Fall Protection
 Anchorage Connectors... 516-517, 519, 560
 Carabiners..... 516, 520
 Davits..... 490-491
 Fall Protection Kits..... 505-507
 Harness..... 496, 500
 Harnesses..... 141, 494-502, 519, 560
 Kits..... 505-507
 Lanyards..... 141, 492, 507-515, 522-524, 560
 Life Lines..... 492, 512-515, 517-518, 520
 Rescue Hoist..... 492
 Rescue Systems..... 490-492, 496, 518
 Rope Grabs..... 517-518, 520
 Signs..... 806
 Winches..... 492

Fall Protection Kits..... 505-507
Fall Protection Lanyards, Hard Hat..... 420, 522, 524

Fan Forced Heaters..... 1503, 1505
Fan Guards..... 489

Fans
 Ceiling..... 1498
 Drum..... 1497, 1502
 Exhaust..... 1501
 Floor..... 1499
 Fume Extractor..... 1058
 Guards..... 489
 Office..... 1499
 Pedestal..... 1497-1499
 Wall Mounted..... 1497-1499

Fasteners
 Carriage Bolts..... 85, 89
 Eye Bolts..... 194
 Hex Nuts..... 85, 89
 Hook & Loop..... 1577
 Nails..... 1446
 Staples..... 1447
 Thread Repair..... 1307

Faucets
 Bathroom..... 350
 Drum..... 251-252

Fault Detectors, Welding..... 1012, 1020, 1144, 1148

FDA Liners..... 280
Feeders, Cold Wire..... 1091
Feeler Gauge Stock..... 1274

Fences
 Barrier..... 866
 Safety..... 865
 Snow..... 865

Fenders, Dock..... 212

Filament Tape..... 1412
Filament Tape Dispensers..... 1411-1413
File Cleaners..... 1307
File Folders..... 1564, 1579
File Handles..... 1307

Files
 Chain Saw Sharpening..... 1302
 Flat..... 1302-1305
 Half Round..... 1303
 Lathe..... 1303

Mill..... 1304
 Round..... 1302, 1304
 Sets..... 1306-1307
 Square..... 1304
 Thread Repair..... 1307
 Triangular..... 1304-1305
 Warding..... 1305

Filing Boxes..... 1564

Filing Cabinets
 Lateral..... 1562-1563, 1565
 Oversized Files..... 1566
 Vertical..... 1562-1563, 1565

Filing Trays..... 1577

Filler Metals..... 1136-1138, 1140

Fillet Gauges..... 1073

Filter Plate Lenses..... 1122, 1128

Filter Plates..... 1126, 1128

Filter/Regulator/Coalescing Filters..... 1257-1258, 1260

Filter/Regulator/Lubricators..... 1255, 1258-1259

Filter/Regulators..... 1255-1256, 1259

Filters
 ADF..... 1121, 1124-1126
 Air..... 359, 1058, 1251, 1255-1260, 1500, 1506
 Mechanical..... 1059
 Respirator..... 452, 456-461, 464, 475, 480
 Water..... 1585-1586

Finger Splints..... 754

Fingercots..... 600

Finishing Wheels..... 938

Fire Protection
 Blankets..... 656, 753
 Extinguisher Cabinets..... 653
 Extinguisher Covers..... 653
 Extinguishers..... 651-652
 Fire Alarm Protectors..... 654-655
 Signs..... 653, 807, 810, 812, 817, 822
 Smoke Alarm Testers..... 656
 Smoke Alarms..... 655

First Aid
 Airway Kits..... 763
 Ammonia Inhalants..... 734, 763
 Antiseptics..... 729-735, 745, 748-749, 759
 Bandages..... 729-735, 740-743, 745-747
 Blankets..... 729, 732, 756-757
 Burn Care..... 732, 749, 753
 Cabinets..... 739
 Coagulants..... 742, 761
 Compresses..... 731-732, 734, 750
 Cotton Products..... 729, 732, 747
 CPR Devices..... 729-735, 762-763
 Crutches..... 758
 Drench Hoses..... 726
 Dressings..... 728, 734
 Emergency Showers..... 718-719
 Extrication Devices..... 754-755
 Eye Care..... 728, 730, 734-735
 Eyewash Stations..... 716-717, 720-725, 728, 734
 Furnishings..... 757-758
 Instrument Tray..... 751
 Instruments..... 729-735, 747, 751, 756
 Kits..... 729-739, 745
 Leg Splints..... 754
 Lip Balm..... 335, 384, 750
 Literature..... 729-735
 Ointments..... 729-732, 745, 748-749
 Oxygen Mask..... 763
 Sharps Collectors..... 757, 760
 Signs..... 727, 805, 809, 812
 Stethoscopes..... 756
 Stretchers..... 754-755
 Tape..... 729, 744
 Thermometers..... 756
 Wheel Chair..... 758

First Aid Instruments, Sanitizing Solution..... 751

First Aid Room Furnishings..... 757-758

Fit Test Kits, Respirators..... 465

Fitters' Gloves..... 608-613, 618, 1310-1311

Fittings
 Air Hose..... 1234, 1239, 1247, 1250
 Cam & Groove..... 263
 Lubrication..... 999-1001
 Push to Connect..... 1239
Fixtures, Light..... 1520
Flagging Tape..... 869

Flags
 Marking..... 871
 Snow..... 871
 Traffic Control..... 858

Flagstaffs..... 856

Flame Resistant Clothing
 Coats..... 556
 Coveralls..... 538, 554-556
 Hoods..... 556-557
 Jackets..... 555
 Overalls..... 555-556
 Pants..... 554
 Rainwear..... 541-542, 548
 Shirts..... 554

Flame Retardant Clothing, Jackets..... 542, 548

Flange Sealants..... 1026

Flap Brushes..... 937

Flap Discs..... 918-919

Flap Wheels..... 919-920, 937

Flare Nut Wrenches..... 1335-1336

Flares, Traffic Control..... 859

Flaring Tools..... 1374

Flash Free Degreasers..... 1007

Flashback Arrestors..... 1074

Flashing Lights..... 222-223, 863, 866

Flashlights
 12 V..... 1162, 1513
 18 V..... 1162
 AA Cell..... 1511-1519
 AAA Cell..... 1509-1510, 1512, 1514, 1517
 Belt Holsters..... 1509-1511
 C Cell..... 1512-1513, 1516
 Coin..... 1514
 CR123 Cell..... 1511
 D Cell..... 1509-1510, 1517
 Hazardous Locations..... 1513
 Mini..... 1509, 1514, 1517, 1519
 N..... 1513
 Pocket..... 1512, 1515
 Rechargeable..... 1162, 1511, 1513, 1515-1516, 1518-1519
 Tactical..... 1512
 Waterproof..... 1513, 1517-1518

Flat Files..... 1302-1305

Flat Fold Respirator..... 447

Flat Mirrors..... 882

Flat Tip Screwdrivers..... 1309-1312, 1338-1341, 1378, 1383, 1386

Flat Top Dispensers..... 326, 330, 332-333

Flex Head Wrenches..... 1334-1335

Flex Torches..... 1103-1104

Flexible Netting..... 1430

Flint Lighters..... 1073

Flints..... 1073

Flip Charts, TDG..... 854

Flip-Top Mitts..... 604

Floodlights..... 1162, 1520, 1526-1528, 1530

Floor Cleaners..... 310-311, 317

Floor Coating..... 1019, 1044-1045

Floor Coatings..... 311, 362, 873, 1019, 1021

Floor Cranes..... 200, 202

Floor Fans..... 1499

Floor Finishes..... 311, 362

Floor Lamps..... 1527

Floor Lock Brakes..... 231

Floor Paint..... 1019, 1044-1045

Floor Repair..... 1018-1019, 1021, 1045

Floor Scales..... 1496

Floor Scrapers..... 292, 298

Floor Sealers..... 311, 362, 1019

Floor Signs..... 308, 813
 Safety..... 296, 308

Floor Stripper..... 311, 362

Flooring Knives..... 1441

Flowmeters, Welding..... 1068

Fluorescent Lamps / Light Bulbs..... 1524-1526, 1529-1530, 1582

Flux..... 1141, 1145

Foam, Packaging..... 1427

Foam Sealants..... 1023

Folders, File..... 1564, 1579

Folding Chairs..... 382, 1554

Folding Gates..... 82-83, 309, 867

Folding Stretchers..... 754

Folding Tables..... 121, 382, 1557

Food Grade Cleaners, Non-Flammable..... 1004

Food Grade Degreasers..... 1003-1004, 1007

Food Grade Lubricants..... 1008, 1010-1011, 1018

Food Handling Containers..... 175

Food Thermometer..... 1471, 1473

Foot, Splints..... 731, 734, 754

Foot Guards
 Aluminum..... 637
 Plastic..... 637
 Steel..... 637

Foot Warmers..... 636

Footrests..... 1549

Footwear
 Boot Trays..... 889
 Brushes..... 291, 889
 Chemical Resistant Boots..... 631
 Covers..... 289, 527, 534, 632, 889
 Foot Guards..... 637
 Foot Warmers..... 636
 Insoles..... 638
 Knee Boots..... 631-632
 Overboots..... 633
 Overshoes..... 633-634
 Toe Guards..... 637
 Waders..... 633
 Winter Boots..... 635-636
 Work Boots..... 632-633

Footwear Odour Neutralizers..... 750

Force Gauges..... 1484

Forceps..... 751

Forearm Protectors..... 643

Forklift Attachments
 Drum Lifters..... 238-239, 241-242
 Extensions..... 187, 242
 Maintenance Platforms..... 141

Forklift Bump Guard..... 186

Forklift Checklist Kit..... 187

Forklift PPE Battery Kit..... 186

Forks
 Cafeteria..... 1583
 Spading..... 367

Forstner Bits..... 1199-1200

Fountain Brushes..... 799

Fountain Rollers..... 799

Fountains, Water..... 1585-1586

Frames
 Crowd Control..... 880
 Dust Mop..... 293-295, 302

Framing Saws..... 872

Freeze Spray..... 1006

Friction Bolt Anchors..... 516

Full Face Respirators..... 455, 458-459, 462-463, 469

Fume Extractor Fans..... 1058

Fume Extractors..... 1058-1060

Fume Filters, Welding..... 1058-1059

Funnels
 Clean..... 994
 Drum..... 241, 251, 699
 Pail..... 699
 Polyethylene..... 317, 994
 Spill Control..... 699
 Steel..... 993

Furniture Pads..... 1454

Furniture Polish..... 319

Fuse Blocks, TIG Torch..... 1110

-G-

Galvanizing Compounds..... 1014, 1144, 1146-1147

Gantry Cranes.....200

Garage Jacks.....206

Garbage Bag Stands.....383

Garbage Bags.....278-282, 348-349, 383, 761

Garbage Cans.....169, 266-275, 349-350, 383, 761, 1577

Garden Hose Hangers.....378

Garden Hoses.....378

Garden Spades.....366

Gas Cans.....671-672

Gas Cylinder

- Brackets.....1079
- Cabinets.....1077
- Dollies.....1078
- Lockouts.....106
- Racks.....1079
- Stands.....1079
- Trucks.....1078
- Wrenches.....1073

Gas Detectors

- Air Quality.....487, 1474
- Calibration Gas.....484-486
- Carbon Monoxide.....487
- Combustible Gas.....487
- Multi-Gas.....482-486
- Sensor.....484-486
- Single-Gas.....482, 485

Gas Hoses, Welding.....1075, 1110

Gas Torches.....1064

Gasflux[®].....1145

Gasket Remover.....1015

Gaskets.....1025-1026

Gate Valve Lockouts.....784

Gate Valves.....252

Gates

- Expandable.....309
- Folding.....82-83, 309, 867
- Security.....82-84, 216, 866, 878

Gauge Protectors, Welding.....1067

Gauges

- Coating Thickness.....1478
- Drum.....251
- Force.....1484
- Pocket.....1275
- Pressure.....1068, 1224, 1232, 1489
- Thickness.....1478-1479
- Weld Fillet.....1073

Gauze Bandages.....729-735, 743

Gaylord Liners.....4, 280

Gear Wrenches, Sets.....1333-1334, 1337

Gearhead Machines, Drilling.....1267

Gels, Burn Care.....753

General Protection Clothing

- Aprons.....529, 534
- Coveralls.....532-539, 689-693, 697
- Hoods.....527, 534
- Lab Coats.....531-534, 536, 539
- Pants.....534
- Shirts.....534

GFCI

- Cord Sets.....1539
- Outlet Adaptors.....1540
- Outlet Boxes.....1539
- Plugs.....1540
- Power Strips.....1540-1542
- UPS Systems.....1542

GHS

- Information Centres.....848
- Information Charts.....847
- Safety Labels.....844-845
- Wallet Card.....844

Glass Cleaners.....315, 1004

Glasses

- Cases.....407
- Cord Retainers.....408
- Reading.....399
- Safety.....386-403, 407, 1310-1311

Gloves

- Aluminized.....624
- Anti-Vibration.....606-607
- Canvas Cotton.....612, 628
- Chemical Resistant.....583-592
- Coated.....562-580, 591-593, 627-628
- Cotton.....612
- Cut Resistant.....575-581, 613
- Dispensers.....600
- Disposable.....594-600, 656, 729-735, 762
- Dyneema[®].....577, 579, 581
- Electrical.....558-559
- Ergonomic.....601-603, 605
- Fingercots.....600
- Fitters'.....608-613, 618, 1310-1311
- Heat Resistant.....605, 622-624
- High Voltage.....558-559
- Holders.....593, 629
- Impact.....605-607, 644
- Inspection.....625
- Jersey.....628-629
- Kevlar[®].....575-576, 578-579, 581
- Knit.....626, 629
- Latex.....598-599
- Leather.....608-613, 618-621, 1129-1131, 1310-1311
- Natural Rubber.....569, 572
- Neoprene.....590
- Neoprene / Rubber.....589-590
- Nitrile.....563-574, 580, 583-586, 594-597, 656
- Nitrile/Polyurethane.....563-569, 571-574, 580
- Parade / Waiter's.....625
- Polyethylene.....600
- Polyurethane/Nitrile.....562-563, 574-580, 593
- Polyurethane.....562-563, 574-578, 580, 593
- PVC.....571, 591-592, 627-628
- Rubber.....570, 587-589
- Rubber Latex.....570, 586-589
- Sandblasting.....591
- Stainless Steel.....581
- Vinyl.....573, 597-598
- Welding.....619-621, 1129-1131
- Winter Lined.....604-605, 609-618, 626

Glow in the Dark Tape.....811, 870, 872-873

Glow Wands.....858, 860

Glue

- Carpenters'.....1029
- Sticks.....1036, 1418
- White.....1029
- Wood.....1029

Glue Guns.....1035-1036, 1418

Goggles

- Safety.....404-406, 412, 689-697, 1120
- Welding.....1120

Gouging Electrodes.....1087

Gouging Torches.....1087

Grab Bar.....350

Graffiti Removers.....319, 1005, 1043

Grain and Coal Scoops.....366

Grease Control Valves.....1000

Grease Guns.....996-997, 1017, 1161, 1309

Grease Pencils.....1142, 1445

Grease Pumps.....999-1000

Greases

- Bearing.....1017
- Dielectric.....1018
- High Temperature.....1017
- Multi-Purpose.....1011, 1018
- Synthetic.....1018
- White Lithium.....1018

Grinders

- Angle.....916, 1163, 1168-1171
- Angle - Air.....1204, 1211, 1215, 1222
- Bench.....917, 1270
- Die.....1172
- Die - Air.....1204, 1212, 1215, 1220, 1223
- Mini Die - Air.....1215
- Pencil - Air.....1223
- Tungsten Electrode.....1113-1114

Grinding Wheels

- Bench Mounted.....917, 1271
- Depressed Center.....912, 915-916
- Type 27.....912, 915-916
- Zirconium.....913-915

Grip-On Discs.....926

Ground Clamps, Welding.....1086

Grounding Mats.....904

Grounds, Welding.....1086

Grounds Maintenance

- Broadcast Spreaders.....364, 370
- Cultivators.....368
- Forks.....367
- Garden Hose Hangers.....378
- Garden Hoses.....376-378
- Hedge Shears.....369
- Hoes.....368
- Ice Salt.....364
- Lopping Shears.....369
- Picks.....368, 1381
- Rakes.....367
- Shovels.....364-366, 368, 1381
- Sidewalk Scrapers.....368
- Spades.....366
- Sprayers.....320, 371-373
- Sprinklers.....376
- Tree Pruners.....369
- Tree Trimmers.....369
- Turf Edgers.....368
- Wheelbarrows.....172, 370

Guard Rails.....54, 84-85, 489

Guards

- Foot.....637
- Perimeter.....51, 84-85, 88
- Shin.....638
- Toe.....637

Guides, Welding.....1117

Gummed Tape.....1413

Gummed Tape Dispensers.....1411, 1413

Guns

- Air.....1035, 1051, 1225-1230
- Caulking.....1018, 1023-1024, 1035, 1045, 1161
- Garden Hose.....376-377
- Glue.....1035-1036, 1418
- Grease.....996-997, 1017, 1161, 1309
- Heat.....1190-1191
- MIG.....1094-1096
- Nail.....1163, 1446
- Paint.....1051
- Sandblasting.....1057, 1225
- Screw.....1187
- Soldering.....1080-1082

-H-

H.I.D. Lamps / Light Bulbs.....1529-1530

Hacksaws

- Blades.....1300
- Frames.....1300-1301, 1309-1312

Hair Nets.....526-527

Half Mask Respirators.....454-455, 458, 461-464, 469

Half Round Files.....1303

Half Round Rasps.....1305

Halogen Lamps / Light Bulbs

-219, 1524, 1527-1528, 1582

Hammer Bits.....1195-1196

Hammer Drill / Drivers.....1157-1159

Hammer Drills.....1158-1159, 1184-1187

Hammer Tackers.....1446

Hammers

- Air.....1213
- Anti-Vibration.....1364-1365
- Ball Pein.....1309-1312, 1362, 1365, 1380
- Blacksmiths'.....1366
- Brass.....1365
- Brick.....1364
- Chipping.....1087-1088
- Claw.....1309-1312, 1362, 1364, 1380
- Club.....369, 1365-1366

- Copper.....1365
- Dead Blow.....1309-1312, 1362-1363
- Demolition.....1187
- Double Faced.....1366
- Mallets.....1309, 1311, 1362-1363, 1380
- Non-Sparking.....1380, 1386
- Rotary.....1159, 1185-1187
- Scaling.....1364
- Sledge.....369, 1365-1366, 1380
- Soft Face.....1363

Hampers.....303

Hand Chisels.....1194, 1381

Hand Cleaners

- Cream.....331
- Foam.....325, 329, 332
- Gel.....315, 326, 328
- Liquid.....315, 326, 331
- Lotion.....315, 324, 326-329, 332

Hand Creams.....331, 333

Hand Crimpers, HVAC.....1359

Hand Dryers.....351

Hand Lamps.....1525-1528, 1531-1532

Hand Pad Holders.....933-934, 938

Hand Pads.....621, 1131

Hand Powered Drills.....1182-1183, 1186

Hand Pumps.....254-256, 258-259

Hand Reamers.....981

Hand Rollers.....799

Hand Sanitizer Dispensers.....323-324

Hand Sanitizers.....323-324, 333, 760

Hand Scrapers, Non-Sparking.....1382, 1386

Hand Scrubbers.....292, 302, 320

Hand Seamers, HVAC.....1359

Hand Shields, Welding.....1123

Hand Stamps.....795-796, 1117

Hand Taps.....956-960, 974-975, 977, 988

Hand Tools

- Arbor Presses.....208
- Auto Body Repair.....208
- Axes.....368
- Bolt Cutters.....1360-1361
- Cable Cutters.....1085, 1349, 1351-1352, 1361, 1377
- Chisels.....1088, 1194, 1309-1312, 1367-1370, 1381
- Clamps.....1238, 1284-1292
- Crowbars.....368, 1380
- Deburring.....1308
- Drywall Tools.....1052-1053, 1280, 1382, 1386
- Hammers.....369, 1309-1312, 1362-1366, 1380, 1386
- Hex Keys.....81, 1309-1312, 1346-1347, 1383
- Hooks & Picks.....1307
- Insulated Cutters.....1377
- Iron Shear Cutters.....1361
- Knives.....1355, 1371, 1382, 1386, 1440-1442
- Levels.....1115-1117, 1279, 1281-1283, 1461
- Locking Pliers.....1352
- Magnets.....286, 1086, 1297-1299
- Mallets.....1309, 1311, 1362-1363, 1380
- Multi-Purpose.....1355
- Nippers.....282, 383, 1357
- Non-Sparking.....1380-1383, 1385-1386
- Nut Drivers.....1342, 1378
- Paper Cutters.....1427, 1432-1433
- Pinch Bars.....1367, 1380
- Pipe Tools.....1115-1117, 1309, 1372-1374, 1378
- Pliers.....364, 1288, 1309-1312, 1348-1354, 1377, 1383, 1386
- Pry Bars.....1309-1312, 1340, 1366-1367, 1380, 1386
- Pullers.....1309-1310, 1312, 1368-1370
- Punches.....1315-1322, 1324
- Rebar Cutters.....1361
- Rolling Head Bars.....1367
- Rotary Cutters.....1163
- Saws.....1300-1301, 1309-1312
- Scissors.....1356-1357, 1442, 1580
- Scrapers.....292, 298, 1382, 1386
- Screwdriver Bits.....1340, 1343-1345

Screwdrivers..... 1309-1312, 1338-1341, 1378, 1383, 1386	Hex Keys 81, 1309-1312, 1346-1347 Non-Sparking..... 1383	HVAC Air Conditioners..... 1500 Air Filters..... 359, 1058, 1500, 1506 Air Purifiers..... 1500 Axial Blowers..... 488-489 Ceiling Fans..... 1498 Ceiling Mounted Heaters..... 1504 Centrifugal Blowers..... 489 Drum Fans..... 1497, 1502 Exhaust Fans..... 1501 Fan Forced Heaters..... 1503, 1505 Fan Guards..... 489 Floor Fans..... 1499 Fume Extractors..... 1058-1060 Fume Filters..... 1058-1059 Hand Crimpers..... 1359 Hand Seamers..... 1359 Humidifiers..... 1500 Mechanical Filters..... 1059 Office Fans..... 1499 Pedestal Fans..... 1497-1499 Portable Blowers..... 359, 488, 1059-1060 Portable Heaters..... 1504 Radiant Heaters..... 1503-1505 Radiator Heaters..... 1503 Smoke Ejectors..... 1501 Tent Heaters..... 489 Wall Heaters..... 1504 Wall Mounted Fans..... 1497-1499	Impact Sockets 1323-1327
Sealing Spatula..... 1052	Hex Nuts 85, 89	Air Purifiers..... 1500	Impact Wrenches Air..... 1205, 1208, 1210, 1214, 1222 Cordless..... 1159-1160 Electric..... 1181
Shears..... 1356-1357	Hex Square Drive Bits 1340, 1343	Exhaust Fans..... 1501	Incandescent Lamps / Light Bulbs 1525-1526, 1528, 1532, 1582
Snips..... 1357-1359	Hex Wrenches 1372, 1378	Fan Forced Heaters..... 1503, 1505	Indigestion Relievers 752
Socket Sets..... 1309-1315, 1325-1326	Hexagonal Dies 978-979	Fan Guards..... 489	Indoor / Outdoor Thermometers 1472
Sockets..... 1309-1310, 1312-1327, 1385	High Heat Coating 1042-1043	Floor Fans..... 1499	Industrial Cleaners Aluminum..... 1145 Bleach..... 314 Boot and Shoe..... 889 Brake..... 1005, 1015 Carpet..... 317 Coil Cleaner..... 1005 Dish Detergents..... 316 Disinfectants..... 313-314, 318, 759-760 Drain..... 316 Floor..... 310-311, 317 Food Grade..... 1004 Furniture Polish..... 319 Glass..... 315, 1004 Graffiti Removers..... 319, 1005, 1043 Heavy-Duty..... 1037 Machine..... 320 Multi-Purpose..... 312-316, 319, 1003-1004, 1037 Non-Chlorinated..... 1020, 1144 Oven..... 316 Rust Removers..... 1014, 1146 Scouring Powder..... 316 Stainless Steel..... 316, 319, 1004 Toilet Bowl..... 314 Urinal..... 349
Squares..... 1280-1281	High Heat Paint 1042-1043	Fume Extractors..... 1058-1060	Industrial Jacks 207
Technicians'..... 1309-1312, 1378-1379	High Temperature Greases 1017	Fume Filters..... 1058-1059	Inflator Gauges, Tire 1224
Tubing Cutters..... 1374	High Visibility Clothing Hat/Toque..... 549 Jackets..... 547-548 Overalls..... 543 Pants..... 548, 551 Parkas..... 547 Rain Jackets..... 543 Rain Suits..... 543 Sweatshirts..... 547 T-Shirts..... 547 Vests..... 545-547	Hand Crimpers..... 1359	Information Centers, MSDS 848-849
Vises..... 1293-1296	High Voltage Gloves 558-559	Hand Seamers..... 1359	Information Centres GHS..... 848 SDS..... 848-849
Wedge..... 1381	Hi-Liters 1578	Humidifiers..... 1500	Information Charts GHS..... 847 WHMIS..... 847
Wrecking Bars..... 1366	Hinges, Weld-On 1088	Mechanical Filters..... 1059	Infrared Thermometers 1469-1470
Wrenches..... 960, 977, 1309-1312, 1330-1337, 1384-1386	Hip Waders 633	Office Fans..... 1499	Inhalants, Ammonia 734, 763
Hand Towels 334, 340-344, 384, 1005, 1583	Hoes 368	Portable Blowers..... 359, 488, 1059-1060	Ink, Stencil 799
Hand Truck Step Ladder 1581	Hoist, Rescue 492	Portable Heaters..... 1504	Ink Stencils 797
Hand Trucks 144-146, 148-151, 1454, 1554	Hoists Air..... 191 Electric..... 191 Manual..... 190-191, 199	Radiant Heaters..... 1503-1505	In-Line Drills, Air 1209, 1221
Hand Warmers 629	Hold-Down Clamps 1290-1292	Radiator Heaters..... 1503	In-Line Filters 1251, 1256
Hand Winches 195	Holders Cell Phone..... 443, 1387, 1390 Chisel..... 1367 Electrode..... 1084 Gloves..... 593, 629 Hand Pad..... 933-934, 938 TDG..... 851 Tool..... 986 Tool Storage..... 1387-1388, 1392	Smoke Ejectors..... 1501	In-Line Lubricators 1251, 1256, 1261
Handles File..... 1307 Torch..... 1065	Hole Saw Arbors 1193, 1198	Tent Heaters..... 489	In-Line Regulators 1232, 1256, 1261
Handling Labels 1430, 1448	Hole Saws 1197-1198	Wall Heaters..... 1504	Insect Repellent 335, 384
Hangers Clothes..... 1581 Garden Hose..... 378 Merchandise Display..... 1435	Hood, Respirators 473, 479, 1127	Wall Mounted Fans..... 1497-1499	Insect Sting Relief 749
Hanging Scales 203, 1493-1494, 1496	Hoods Arc Flash..... 556-557 Flame Resistant..... 556-557 General Protection..... 527, 534 Rain..... 541-543, 548	Hydrogen Peroxide..... 734, 748, 759	Inserts, Pail 235
Hard Hat Lanyards 420, 522, 524	Hole Saw Arbors 1193, 1198	Hydrophobic Coating..... 638, 1045	Insoles 638
Hard Hat Liners, Cooling 646	Hole Saws 1197-1198	Hygienic Products Basins..... 731, 734, 751, 758 Sanitary Napkins..... 348-349 Shampoo..... 325, 329 Tampons..... 348	Inspection Cameras 1376, 1485 Borescope..... 1485
Hard Hats 414-418	Hood, Respirators 473, 479, 1127	Hygrometers, Thermo..... 1474, 1476	Inspection Gloves 625
Hardness Testers Non-Metals..... 1479 Steel & Alloys..... 1479	Hooks & Loop Fasteners 1577		Inspection Mirrors 883
Hardware Shims..... 1273-1274 Stock..... 1274	Hooks Clevis Grab..... 192-193 Clothes..... 350 Drum Lifting..... 243 Lifting..... 192-193 Sky..... 199 Slip..... 192-193		Instant Adhesives 1031-1032
Harnesses Arc Rated..... 500, 560 D-Ring..... 495 General..... 141, 494-499, 501-502, 519 Traffic Control..... 548 Welding..... 496, 500	Hooks & Picks 1307		Instrument Tray 751
Hasp Lockouts 764, 768-769, 780	Hoppers, Self-Dumping 171		Instruments Anemometers..... 1486-1487 Balometers..... 1488 Bi-Metal Thermometers..... 1473 Borescope..... 1485 Cable Tracers..... 1468, 1543 Calipers..... 1275, 1309-1310 Circuit Testers..... 1461, 1539 Clamp Meters..... 1460-1461, 1466, 1468, 1540 Conductivity Meters..... 1490 Cooking Thermometers..... 1471, 1473 Counters..... 1483 Digital Thermometers..... 1472-1473 Distance Measurers..... 1276-1279, 1309-1312, 1482, 1484 Feeler Gauge Stock..... 1274 First Aid..... 729-735, 747, 751, 756 Force Gauges..... 1484 Gas Detectors..... 482-487, 1474 Hardness Testers..... 1479
Hats Cooling..... 645 Hard..... 414-418	Horizontal Sheet Rack 53		
Hawks 1053	Horns 221 Signal..... 444		
Hazardous Materials Cabinets 658, 660-667	Hose Clamps 1238		
Hazardous Materials Signs 808	Hose Fittings 1234, 1239, 1247, 1250 Welding..... 1074		
Head Assemblies, MIG Gun 1095	Hose Protectors, Dock 217		
Headbands, Cooling 645, 647	Hose Reel Carts 1237		
Headgear, Respirators 473, 479, 1127	Hose Reels 1076, 1234-1237, 1532		
Headlights, Hard Hat 419, 549	Hose Repair Kits 377 Welding..... 1075		
Headsets 435, 438-439	Hose Whips 1250		
Hearing Bands 430-431	Hoses Air..... 1207, 1233-1235 Discharge..... 263 Drench..... 726 Garden..... 378 Loc-Line®..... 1150-1153 Lubricant..... 996 Welding..... 1068, 1075, 1110		
Heat Guns 1190-1191	Hot Compresses 731-732, 734, 750		
Heat Resistant Clothing Aprons..... 551 Coats..... 551 Leggings..... 551	Humidifiers 1500		
Heat Resistant Gloves 605, 622-624	Humidity Labels 1429		
Heat Resistant Mitts 622	Humidity Meters, Infrared 1475		
Heat Stress Meter 645, 1475			
Heaters Ceiling Mounted..... 1504 Drum..... 237 Fan Forced..... 1503, 1505 Pail..... 237 Portable..... 1504 Radiant..... 1503-1505 Radiator..... 1503 Tent..... 489 Wall..... 1504			
Heating Tips 1072			
Hedge Shears 369			
Helmets, Welding 481, 1121-1127			
Hex Bit Sockets 1315-1316			
Hex Bits 1344			



I-Beam Frame Levels 1281	Ibuprofen 752
Ice Cleats 636	Ice Salt 364
Ice Spikes 636	Identification Fountain Brushes..... 799 Fountain Rollers..... 799 GHS Products..... 844, 847 Grease Pencils..... 1142, 1445 Hand Rollers..... 799 Hand Stamps..... 795-796, 1117 Label Holders..... 5, 12, 48, 72-73, 1571 Label Makers..... 5, 12, 824-830, 1572-1574 Labels..... 818-819, 844-845 Lumber Crayons..... 1142, 1444 Marking Flags..... 871 Metal Markers..... 1444 MSDS Products..... 667, 848-849 Paint Markers..... 1142, 1442-1444 Paint Sticks..... 1142, 1443-1444 Pipe Markers..... 833-841 Safety Whips..... 856 SDS Products..... 847-849 Self-Adhesive Letters..... 800 Self-Adhesive Numbers..... 800 Signs..... 12, 48, 210, 308, 653, 727, 758, 803-817, 820-823, 849, 851, 857-859 Snow Flags..... 871 Soapstone..... 1143 Stencil Inks..... 799 Stencils..... 797-798 Tags..... 12, 786-788, 790-793, 1448 Tape..... 811, 868-870 TDG Products..... 851-854 WHMIS Products..... 845-847 Windsocks..... 871
Illuminometers, Digital 1481	Impact Gloves 605-607, 644
Impact Labels 1430	

Heat Stress Meter.....	645, 1475	Pipe.....	1115	Straws.....	1583	Laminators, Document	1574
Humidity Meters.....	1475	Trailer.....	212	Table Caddies.....	1557	Lamps	
Hygrometers.....	1474, 1476	Janitorial Products		Tables.....	382, 1556-1557	Desk.....	1524, 1582
Illuminometers.....	1481	Broom & Mop Racks.....	286	Kits		Floor.....	1527
Indoor / Outdoor Thermometers.....	1472	Brooms.....	287-290, 301	Airway.....	763	Fluorescent.....	1524-1526, 1529-1530, 1582
Infrared Thermometers.....	1469-1470	Brushes.....	26, 291-292, 300-301,	Auto Body Repair.....	208	H.I.D.....	1529-1530
Inspection Cameras.....	1376, 1485	349, 946, 1383, 1386	Burn Care.....	753	Halogen.....	219, 1524, 1527-1528, 1582
Inspection Mirrors.....	883	Buckets.....	305-307	CPR.....	763	Incandescent.....	1525-1526, 1528, 1532, 1582
Insulation Testers.....	1467	Buckets / Wringers.....	306-307	Fall Protection.....	505-507	LED.....	219
LCR Meters.....	1468	Burnishing Pads.....	362	First Aid.....	729-739, 745	Lanterns	
Light Meters.....	1481	Carts.....	275, 309	Laser Distance.....	1482	6 V.....	1517
Magnifiers.....	1524	Cleaning Pads.....	292, 294, 302, 320, 362	Lockout.....	772, 777-779	Cordless.....	1516
Manometers.....	1487-1488	Cloths.....	293-294	Power Tool Combo.....	1164-1166	Waterproof.....	1518
Micrometers.....	1275	Dusters.....	294, 302, 320	Spill Control.....	689-698, 760	Lanyards	
Moisture Meters.....	1477	Dustpans.....	290, 296, 687	Welding Torch.....	1064, 1109	Arc Rated.....	510, 560
Motor Rotation Testers.....	1468	Extension Poles.....	287-288, 292-294,	Knee Boots	631-632	Eyewear.....	408
Multi-Function Testers.....	1462	297-299, 302, 1048	Knee Pads		Hard Hat.....	420, 522, 524
Multimeters.....	1460, 1462	Funnels.....	317, 993-994	Co-Polymer / Ester Tricot.....	639	Positioning and Restraint.....	508
Oral Thermometers.....	756	Hand Towels.....	Foam.....	640	Self-Retracting.....	492, 512-513, 515
ORP Meters.....	1490	334, 340-344, 384, 1005, 1583	Foam / Hard Shell.....	640	Shock Absorbing.....	141, 507-510
pH Meters.....	1490	Liquid Measures.....	993	Gel.....	639-640	Tie-Back.....	509-510
Phase Rotation Testers.....	1468	Measuring Cups.....	317, 994	Hard Shell.....	640	Tool.....	522-524
Pocket Gauges.....	1275	Mops.....	292-295, 304-306	Leather.....	1133	Welding.....	510
Porosity Detectors.....	1478	Pressure Washers.....	374-375	Rubber.....	640	Laser Distance Kits	1482
Pressure Gauges.....	1068, 1224, 1232, 1489	Scoops.....	363, 366, 694, 994	Knelling Pads	639	Laser Levels	1282-1283, 1461
Psychrometers.....	1475	Scrubbers.....	292, 302, 320	Knit Gloves	626, 629	Latch Clamps	1290-1292
Refractometers.....	1490	Squeegees.....	296-299, 301, 687	Knives		Latex Coating	1042
Scales.....	203, 1433, 1491-1496	Sweepers.....	286, 358	Cafeteria.....	1583	Latex Paint	1042
Sound Level Meters.....	440, 1480-1481	Trigger Sprayers.....	302, 320	Curved Blade.....	1382, 1386	Laundry Equipment	
Stem Thermometers.....	1473	Vacuum Cleaners.....	352-361, 688, 1225	Drywall.....	1052-1053, 1382, 1386	Bags.....	303
Stopwatches.....	645, 1475, 1483	Washroom Products.....	314, 321-322,	Flooring.....	1441	Carts.....	303
Stroboscopes.....	1483	340-351, 1375, 1583	Linoleum.....	1382, 1441	Detergents.....	317
Surface Mount Thermometers.....	1473	Waste Management.....	169, 236, 266-285,	Packaging.....	1309, 1312, 1425,	Hampers.....	303
Tachometers.....	1482	290, 348-350, 383, 657, 761, 1037, 1577	1430, 1434, 1438-1442	Ironer Trucks.....	303
Temperature Probes.....	1471, 1475, 1488	Water Brooms.....	377	Pocket.....	1355	Linen Trucks.....	303
Temperature Recorders.....	1476	Window Washers.....	299	Putty.....	1052, 1382, 1386	Lava Nozzles	1105
Thermal Cameras.....	1470	Wipes.....	316, 318, 332, 334-339,	Roofing.....	1441	Layout Fluids	1145, 1148
Thermocouple Thermometers.....	1429, 1471, 1474-1475	384, 465, 759-760, 1054	Rubber Cutting.....	1371, 1441	L-Clamps	1284
Thermometer / Hygrometers.....	645, 1472, 1474-1476	Wipes Dispensers.....	334, 336, 338-340	Straight Blade.....	1382, 1386	LCR Meters	1468
.....	1478-1479	Wringers.....	294, 307	Utility.....	1382, 1440-1442	Leads, Test	1463
Thickness Gauges.....	1478-1479	Jars, Storage	28	Knockout Tools	1162	Leak Diverters	683
Time Clocks.....	1575	Jelly, Petroleum	749	Kraft Paper	1428, 1430	Leak Plug	683
Timers.....	378, 1483	Jerry Cans	671-672	Leak Seal	683	Leather Gloves	
Torque Meters.....	1329	Jersey Gloves	628-629	608-613, 618, 621, 1131, 1310-1311	LED Lamps / Light Bulbs	219
Torque Multipliers.....	1328	Jib Booms	201	Lab Coats	550	Leg / Arm Bands, Traffic Control	548
Torque Screwdrivers.....	1329	Jib Cranes	201	General Protection.....	531-534, 536, 539	Leggings, Heat Resistant	551
Torque Wrenches.....	1328	Jig Saws		Label Holders	5, 12, 48, 72-73, 1571	Lens Cleaners	
Vibration Meters.....	1484	Heavy-Duty.....	1178	Label Makers		Solutions.....	409
Voltage Testers.....	1462, 1543	Orbital.....	1178	Accessories.....	5, 12, 825, 827-828	Stations.....	409
Wall Clocks.....	1575	Jiggers	144, 182-186	Portable.....	824-825, 827, 1572-1574	Tissues.....	409
Insulated Cutters	1377	Jobsite Boxes	36, 1394, 1401-1407	Ribbons.....	824-828, 830, 1573	Towellettes.....	409, 465, 760
Insulation Testers	1467			Software.....	1574	Lenses, Filter Plate	1122, 1128
Insulator Caps, MIG Gun	1098			Table Top Versions.....	828, 1572-1573	Letters, Self-Adhesive	800
Insulators, TIG Torch	1108			Tapes.....	825-826, 828-830, 1572-1574	Levelers, Dock	214
Integral Probe Anemometers	1486-1487			Labels		Leveling Mounts	1272
Iron Shear Cutters	1361	Keel Klamp® Pipe Fittings	79-81	GHS Safety.....	844-845	Levels	
Ironer Trucks	303	Keel Klamp® Piping	81	Handling.....	1430, 1448	Chalk Lines.....	1279
Irons, Soldering	1080-1082	Key Boxes	654	Humidity.....	1429	I-Beam Frame.....	1281
ISO Safety Labels	818-819, 845	Key Cabinets	1570	Impact.....	1430	Laser.....	1282-1283, 1461
Isolators, Vibration	1272	Key Chains	1570-1571	ISO Safety.....	818-819, 845	Pipefitting.....	1115-1117
Isopropyl Rubbing Alcohol	748	Key Racks	1570	Lock.....	770	Plumb Bobs.....	1279, 1283
		Key Rings	794	TDG.....	855, 1448	Pocket.....	1115
		Key Tags	1570	Temperature.....	1429	Torpedo.....	1281
		Keyboard Trays	1558	WHMIS.....	846	Lever Pumps	256
		Keyboard Wrist Rests	1558	Ladder, Step Stool Hand Truck	1581	Lids	266, 268, 271-272, 276-277
		Keys, Hex	81, 1309-1312, 1346-1347, 1383	Ladder Trucks	134	Drum.....	236, 670, 699
		Kitchen Supplies		Ladders		Pail.....	236
		Aluminum Foil.....	1583	Crossover.....	140	Waste Container.....	266, 268, 271-272, 276-277
		Cling Wrap.....	1583	Double Stepladders.....	129-131	Life Lines	
		Coffee Equipment.....	1583-1584	Escape.....	656	Self-Retracting.....	492, 512-515, 518
		Coolers.....	1586	Extension.....	132-133, 135	Vertical.....	517, 520
		Cup Dispensers.....	1583	Multi-Purpose.....	131-132, 1150	Lift Tables	178-179, 181, 184
		Cups.....	1583	Platform.....	127, 129-131, 135	Lifters	
		Forks.....	1583	Rolling.....	135, 137-140	Drum.....	238-243, 701
		Knives.....	1583	Single.....	127, 132-133	Shop.....	180, 703
		Microwave Ovens.....	1584	Stairway.....	140	Lifting Equipment	
		Napkin Dispensers.....	343-344, 1583	Stepladders.....	127-128, 134-135	Aircraft Cables.....	194
		Napkins.....	343-344, 1583	Stepstands.....	135-137	Beam Clamps.....	199, 519
		Plates.....	1583	Stepstools.....	134, 136, 1549	Beam Trolleys.....	190, 519
		Refrigerators.....	1584	Trestle Stepladders.....	129-131	Chain.....	193
		Spoons.....	1583				
		Stirring Sticks.....	1583				

Clevis Grab Hooks.....192-193
 Cranes.....200-202, 208
 Engine Tilters.....208
 Hoists.....190-191, 199
 Hooks.....192-193
 Jacks.....206-208, 212
 Jibs.....201
 Lift Tables.....178-179
 Lifting Clamps.....198
 Magnetic Lifters.....196, 198, 1298
 Manhole Lid Lifters.....489
 Pallet Lifters.....181, 184, 201
 Pallet Trucks.....144, 182-186
 Skid Lifts.....181, 184
 Sky Hooks.....199
 Slings.....188-189
 Slip Hooks.....192-193
 Stackers.....180, 703
 Vacuum Cups.....196-197

Light Bulbs
 Fluorescent.....1524-1526, 1529-1530, 1582
 H.I.D.....1529-1530
 Halogen.....219, 1524, 1527-1528, 1582
 Incandescent.....1525-1526, 1528, 1532, 1582
 LED.....219

Light Fixtures.....1520
Light Meters, Digital.....1481
Lighters, Flint.....1073

Lighting
 Bay Lights.....1520
 Desk Lamps.....1524, 1582
 Dock Lights.....218-220
 Emergency Lights.....1521-1522
 Exit Lights.....1521
 Flashing Lights.....222-223, 863, 866
 Flashlight Belt Holsters.....1509-1511
 Flashlights.....1162, 1509-1519
 Floodlights.....1162, 1520, 1526-1528, 1530
 Floor Lamps.....1527
 Hand Lamps.....1525-1528, 1531-1532
 Headlights.....419, 549
 Lamps / Light Bulbs.....219, 1524-1530, 1532, 1582
 Lanterns.....1516-1518
 Lightsticks.....858, 860
 Penlights.....1512
 Spot Lights.....187, 1516, 1518
 String Lights.....1528
 Task Lights.....1523, 1529-1530
 Telescopic Lights.....1528
 Traffic Wands.....1509
 Warning Lights.....222-223, 863, 866

Lighting Baton.....858, 860
Lightsticks.....858, 860

Limited Use Clothing
 Aprons.....529-531, 533-534
 Coveralls.....532-533, 535-539, 689-693, 697
 Hoods.....527, 534
 Lab Coats.....531-534, 536, 539
 Pants.....534
 Shirts.....534

Line Stripping Paint.....1039
Lineman's Pliers.....1309-1312, 1348
Linen Trucks.....303

Liners
 Container.....280
 Drum.....235
 Gaylord.....4, 280
 Hard Hat.....418, 553
 MIG Gun.....1095-1097
 Waste Container.....267, 269-270, 273, 285

Linoleum Knives.....1382, 1441
Lip Balm.....335, 384, 750
Liquid Measures.....993
Liquid Tip Markers.....846, 1445, 1578
Literature, First Aid.....729-735
Literature Displays.....1568
Litter Pickers.....282, 383
Litter Scoops.....282, 290, 383
Load Binders.....192
Lock Labels.....770
Locker Room Benches.....108, 382

Lockers
 Plastic.....109-110
 Steel.....104-108

Locking Pliers.....1288, 1309-1312, 1351-1354

Lockouts
 Ball Valve.....780, 782-784
 Butterfly Valve.....783
 Cable.....779
 Circuit Breaker.....781-782
 Confined Space.....784
 Electrical Plug.....781-782
 Electrical Switch.....781
 Gas Cylinder.....106
 Gate Valve.....784
 Hasps.....764, 768-769, 780
 Kits.....772, 777-779
 Pneumatic Fitting.....1250
 Pump.....259
 Stations.....772-779
 Tags.....786-790

Lockouts Dielectric, Hasps.....780

Locks
 Dielectric Padlocks.....769
 Padlocks.....99, 110, 764-772
 Wheel.....782

Loc-Line® Hosing.....1150-1153

Logistic Straps.....246, 1456

Logistic Tracks.....212, 1457

Long Nose Pliers.....1309-1312, 1348, 1351, 1377

Loosefill.....1428

Lopping Shears.....369

Lotions, Body.....749

Loudspeakers.....444

Lubricants
 Air Tool Oil.....1037, 1261
 Anti-Seize.....1016
 Bearing Greases.....1017
 Cutting Fluids.....1148-1149
 Dielectric Greases.....1018
 Dry.....1008-1010, 1012
 Food Grade.....1008, 1010-1011, 1018
 Freeze Spray.....1006
 General Purpose.....1013
 Graphite.....1008
 High Temperature Greases.....1017
 Layout Fluids.....1145, 1148
 Machinery Oil.....1011
 Mold Release.....1009
 Multi-Purpose Greases.....1011, 1018
 Penetrants.....1004, 1012-1013, 1020, 1144
 Pump.....1144
 Silicone.....1008, 1010
 Spray.....1008-1013, 1018
 Synthetic.....1009, 1012
 Synthetic Greases.....1018
 Tapping Compounds.....1149
 White Lithium.....1018
 White Lithium Greases.....1018
 Wire Pulling.....1012, 1543

Lubricating Equipment
 Control Valves.....1000
 Fittings.....999-1001
 Grease Guns.....996-997, 1017, 1161, 1309
 Grease Pumps.....999-1000
 Hoses.....996
 Loc-Line Hosing.....1150-1153
 Oil Cans.....999

Lubricators, In-Line.....1251, 1256, 1261

Lugs, Welding Cable.....1085

Lumber Carts.....159-160
Lumber Crayons.....1142, 1444



Machine Cleaners, Heavy-Duty.....320
Machine Stands.....120
Machine Taps.....976
Machine Tool Pumps.....1150
Machine Vises.....1295
Machine Wrap.....1426

Machinery
 Bandsaws.....1178
 Drilling Machines.....1188-1189, 1266-1267
 Rollers.....204-205
 Sandblasting Equipment.....1055-1057, 1225
 Shrink Wrap.....1426

Machinery & Operations Signs.....804-805, 809

Machinery Oil.....1011
Machinery Rollers.....204-205
Magnetic Brooms.....290
Magnetic Lifters.....196, 198, 1298
Magnetic Retrievers.....1297-1298
Magnetic Tags.....12

Magnets
 Bar.....1298
 Ceramic.....1299
 Cup.....1299
 Print Holders.....1298
 Rare Earth.....1299
 Retrievers.....1297-1298
 Strip.....1298
 Sweeper.....286
 Welding Grounds.....1086
 Welding Squares.....1086

Magnifier Plates.....1126, 1128

Magnifiers
 Illuminated.....1524
 Lenses.....1524

Mail Sorters.....1566
Mailboxes.....1576
Mailers.....1434-1435
Maintenance Brushes.....26, 300-301, 1383, 1386
Maintenance Platforms.....141
Maintenance Signs.....808-809, 813
Mallets.....1309, 1311, 1362-1363, 1380
Manhole Lid Lifters.....489
Manhole Shields.....489, 491
Manifolds, Air.....1250
Manometers.....1487-1488
Marine Jacks.....207

Markers
 Liquid Tip.....846, 1445, 1578
 Lumber Crayons.....1142, 1444
 Metal.....1444
 Office.....823, 846, 1442, 1445, 1569, 1578
 Paint.....1142, 1442-1444
 Paint Sticks.....1142, 1443-1444
 Permanent.....1442, 1445, 1578
 Pipe.....833-841
 Pipe Contour.....1116-1117
 Soapstone.....1143
 Whiteboard.....823, 1569

Marking Flags.....871
Marking Paint.....1038, 1040
Marking Paint Applicator.....1040
Marking Wands.....1038-1040
Masking Tape.....1414
 Painter's.....1050

Masks
 CPR.....729-730, 762-763
 Dust.....447, 453

Material Handling
 Box Trucks.....166, 172-175
 Cargo Bars.....212, 1457
 Carts.....660, 662
 Conveyors.....224-225
 Decking & Shoring Beams.....212, 1457
 Dollies.....20, 97, 103, 176-177, 208-209, 1078
 Drywall Carts.....159
 Engine Stands.....208
 Forklift Bump Guard.....186
 Forklift Checklist Kit.....187
 Forklift Extensions.....141, 187, 242
 Forklift PPE Battery Kit.....186
 Gas Cylinder Trucks.....1078
 Hand Trucks.....144-146, 148-151, 1454, 1554
 Hoppers.....171
 Lifting Equipment.....144, 178-202, 206-208, 212, 489, 519, 703, 1298
 Load Binders.....192

Lumber Carts.....159-160
 Pallet Turntables.....181
 Panel Trucks.....158-160
 Pipe Trucks.....160-161
 Platform Trucks.....152-158, 160, 165
 Reel Dispensers.....167
 Reel Racks.....78
 Security Carts.....77
 Semi-Live Skids.....154, 158
 Shop Carts.....7-8, 42, 73, 76-77, 161-170
 Stands.....207, 209
 Step Ladder Hand Truck.....1581
 Stock Trucks.....166
 Tilt Trucks.....172-173
 Tricycles.....161
 Wagons.....154, 157, 370
 Winches.....195
 Wire Spool Carts.....167
 Work Positioners.....181
 Work Stands.....209, 225

Mats, Grounding.....904

Matting
 Anti-Fatigue.....891-894, 896-897, 899-900, 902-909
 Anti-Static.....560, 903-904
 Clean Room.....907
 Eco.....886
 Entrance.....874, 885-888, 901, 909
 Eyewash Stations.....727, 893
 Runner.....885-888, 901, 909
 Welding.....904, 1119
 Wiper.....874, 885-887

Measurement Devices
 Laser Distance Kits.....1482
 Measuring Counters.....1484
 Tape.....1276-1279, 1309-1312
 Wheels.....1278, 1482, 1484
 Wire Measurers.....1484

Measures, Liquid.....993

Measuring Counters.....1484
Measuring Cups.....317, 994

Measuring Tape
 Oil Gaging.....1279
 Reel.....1279
 Retractable Blade.....1276-1278, 1309-1312

Measuring Wheels.....1278, 1482, 1484

Mechanical Filters.....1059
Mechanic's Dollies.....209
Media, Sandblasting.....1055
Media Recyclers, Sandblasting.....1055-1056

Medicine
 Acetaminophen.....752
 Antacids.....752
 Cough and Cold Relief.....752
 Ibuprofen.....752

Megaphones.....444
Mesh Enclosures.....90
Mesh Partitions.....51, 84-85, 88-89
Message Pads.....1579
Metal Markers.....1444
Metal Snips.....1357-1359
Metal Working Fluids.....1145, 1148-1149
Microfiber Cloths.....293-294
Micrometer, Vernier.....1275
Micrometers, Digital.....1275
Microwave Ovens.....1584
MIG Guns.....1094-1096
MIG Pliers.....1088
MIG Welders.....1092-1093

MIG Wire
 Aluminum.....1138
 Bronze.....1138
 Copper.....1138
 Steel.....1135, 1137

Mini Die Grinders, Air.....1215

Mirrors
 Bathroom.....350
 Convex.....882
 Dome.....881, 883
 Flat.....882
 Inspection.....883

- Rectangular.....882
- Round.....882
- Mitre Saw Blades**.....1203
- Mitre Saws**.....1175-1176
- Mitts, Heat Resistant**.....622
- Mixers**
 - Drum.....249
 - Pail.....249
 - Paint.....1046
- Mixing Valves, Thermostatic**.....721
- Mobile Bins**.....6
- Moisture Meters**.....1477
- Mold Release Lubricants**.....1009
- Monitor Mounts**.....1558
- Monitor Stands**.....1577
- Mops**
 - Cotton.....304-305
 - Dust.....293, 295
 - Microfibre.....295
 - Poly / Mesh.....305
 - Polyester / Rayon.....304
 - Sponge.....292-293
 - Wet.....292-295, 304-306
- Motor Oil**.....1015
- Motor Rotation Testers**.....1468
- Motors, Coring**.....1189
- Mounts**
 - Cupmounts.....1272
 - Leveling.....1272
 - Monitor.....1558
- Moving Supplies**
 - Cargo Nets.....1455
 - Jack Bars.....1457
 - Logistic Tracks.....212, 1457
 - Moving Blankets.....1454
 - Straps.....150, 246, 1454-1456
 - Tie-Downs.....683, 1455-1457
- MSDS**
 - Binders.....849
 - Information Centers.....848-849
 - Storage Boxes.....667
- Muffs**
 - Cap Mounted.....433-439
 - Headband.....433-438, 549
 - Headstrap.....433-438, 549
 - Hearing.....435
 - Neckband.....434, 436-437
- Multi-Gas Detectors**.....482-486
- Multi-Gas Meters**.....483
- Multimeters**
 - AC/DC.....1460, 1462
 - Electrical.....1460
 - True RMS.....1460
- Multi-Purpose Greases**.....1011, 1018
- Multi-Purpose Hand Tools**.....1355
- Multi-Purpose Ladders**.....131-132, 1150
- Multi-Tip Screwdrivers**.....1340-1341

-N-

- Nail Guns**
 - Cordless.....1163
 - Electric.....1446
- Nails, for Nail Guns**.....1446
- Napkin Dispensers**.....343-344, 1583
- Napkins**
 - Cafeteria.....343-344, 1583
 - Sanitary.....348
- Neck Protectors, Welding**.....1125
- Neck Shades, Cooling**.....647
- Needle Nose Pliers**.....1349, 1351
- Nesting Bins**.....18-19, 26
- Nets**
 - Cargo.....1455
 - Hair.....526-527
- Neutralizers**
 - Battery Acid.....686, 1037
 - Spill Control.....686, 697
- Newsprint**.....1428
- Nibblers**.....1173
- Nippers, End Cut**.....282, 383, 1357

- Nipples, Pipe Thread**.....1240, 1243-1244
- No Smoking Signs**.....806-808, 810
- Non-Aqueous Developers**.....1144
- Non-Chlorinated Cleaners**.....1020, 1144
- Non-Chlorinated Degreasers**.....1144
- Non-Chlorinated Developers**.....1020, 1144
- Non-Sparking Tool Kits**.....1386
- Non-Sparking Tools**
 - Chisels.....1381
 - Hammers.....1380, 1386
 - Hex Keys.....1383
 - Mallets.....1380
 - Pliers.....1383, 1386
 - Scrapers.....1382, 1386
 - Sockets.....1385
 - Spatulas.....1382
 - Wedge.....1381
 - Wrenches.....1384-1386
- Nose Cutting Pliers**.....1350, 1353
- Nozzle Cleaners**.....1143
- Nozzle Gels, MIG Gun**.....1145
- Nozzle Reamers**.....1088
- Nozzles**
 - Garden Hose.....376-377
 - MIG Gun.....1095-1098
 - TIG Torch.....1104-1106
- Numbered Tags**.....793
- Numbers, Self-Adhesive**.....800
- Nut Drivers**
 - Cushion Grip.....1342
 - Hollow Shaft.....1342
 - Insulated.....1378
 - Magnetic.....1342
 - Sets.....1342
- Nuts, Hex**.....85, 89
- Nutsetters**.....1343

-O-

- Odour Neutralizers, Footwear**.....750
- Office, Dry Erase Whiteboard Wipes**.....1569
- Office Desks**.....1567
- Office Fans**.....1499
- Office Seating**.....1546, 1548-1549, 1553-1554
 - Ergonomic.....1547-1549, 1554
- Office Supplies**
 - Binders.....1579
 - Clipboards.....1579
 - Corkboards.....1569
 - Desk Organizers.....1577
 - Directory Boards.....1569
 - Display Hangers.....1435
 - Dry Erase Whiteboard Wipes.....1569
 - File Folders.....1564, 1579
 - Filing Boxes.....1564
 - Grounding Mats.....904
 - Hi-Liters.....1578
 - Literature Displays.....1568
 - Markers.....823, 846, 1442, 1445, 1569, 1578
 - Message Pads.....1579
 - Monitor Mounts.....1558
 - Paper Clamps.....1565
 - Paper Clips.....1580
 - Pencil Sharpeners.....1578
 - Pencils.....729, 732-733, 1578
 - Pens.....1578
 - Printer & Photocopier Paper.....1579
 - Push Pins.....1569
 - Rubber Bands.....1423, 1580
 - Sheet Protectors.....1579
 - Staples.....1446
 - Suggestion Boxes.....1581
 - Tape.....1580
 - Tape Dispensers.....1580
 - Whiteboards.....1569
- Offset Wrenches**.....1373
- Oil**
 - Air Tool.....1037, 1261
 - Machinery.....1011
- Oil Cans**.....999

- Oily Waste Cans**.....670-671
- Ointments, Burn Care**.....749
- Omni-Directional Stands**.....225
- Open End Wrenches**.....1335
- Open Wire Workstations**.....118
- Openers, Pail**.....250
- Oral Thermometers**.....756
- Orbital Sanders, Air**.....1207, 1211-1212, 1218-1219
- Order Picking Carts**.....165
- O-Rings, MIG Gun**.....1095
- ORP Meters**.....1490
- Oscillators, Garden Hose**.....376
- Outdoor Equipment**
 - Bicycle Racks.....379
 - Grounds Maintenance.....172, 320, 364-373, 376-378, 1381
 - Park Benches.....380
 - Picnic Tables.....380
 - Snow Removal.....364, 871
- Outfits, Welding**.....1062-1064
- Outlet Adaptors, GFCI**.....1540
- Outlet Boxes, GFCI**.....1539
- Oval Sleeves**.....194
- Oven Cleaners**.....316
- Ovens, Electrode**.....1089
- Overalls**
 - Arc Flash.....555-556
 - Flame Resistant.....555-556
 - Rain.....542
- Overboots**.....633
- Overpack**.....689-690, 693, 697, 700-702, 713
- Overshoes**.....633-634
- Oxygen Hoses, Welding**.....1075
- Oxygen Masks, Kits**.....763

-P-

- Packaging**
 - Benches.....1433
 - Boxes.....1431
 - Bubble Pouches.....1435
 - Bubble Wrap.....1427
 - Bungee Cords.....1455, 1457
 - Cable Tie Tools.....1452
 - Cable Ties.....793-794, 1435, 1452
 - Corrugated Paper.....1430
 - Desiccants.....1429
 - Edge and Corner Protectors.....48, 86-87, 216, 1421, 1423
 - Flexible Netting.....1430
 - Foam.....1427
 - Handling Labels.....1429-1430, 1448
 - Knife Blades.....1425, 1430, 1434, 1438-1442
 - Knives.....1309, 1312, 1425, 1430, 1434, 1438-1442
 - Kraft Paper.....1428, 1430
 - Loosefill.....1428
 - Mailers.....1434-1435
 - Moving Straps.....150, 246, 1454-1456
 - Newsprint.....1428
 - Packing List Envelopes.....1449
 - Pads.....1431
 - Poly Bags.....1436
 - Poly Tubing.....1430, 1437
 - Rope.....1450
 - Shrink Wrap.....1426
 - Shrink Wrap Machines.....1426
 - Staple Removers.....1447
 - Staplers.....1446-1447
 - Staples.....1446-1447
 - Strapping.....1419-1422
 - Stretch Wrap.....1424-1426
 - Stretch Wrap Dispensers.....1424-1426
 - Tamper Seals.....1451
 - Tape.....829, 1410-1416, 1429, 1436
 - Tape Dispensers.....1411-1413, 1416, 1429
 - TDG Labels.....855, 1448
 - Temperature Labels.....1429
 - Tie-Downs.....683, 1455-1457
- Pail Dollies**.....244
- Pail Funnels**.....699
- Pail Heaters**.....237
- Pail Inserts**.....235
- Pail Mixers**.....249
- Pail Openers**.....250
- Pail Tipplers**.....245
- Pail Tumblers**.....248
- Pails**.....27, 695-696
- Pain Relievers**.....752
- Paint**
 - Acrylic.....1040, 1042-1044
 - Alkyd.....1040-1041, 1043-1044
 - Antislip.....1045
 - Applicator.....1040
 - Epoxy.....1042-1043
 - Floor.....1019, 1044-1045
 - High Heat.....1042-1043
 - Latex.....1042
 - Line Striping.....1039
 - Marking.....1038, 1040
 - Rubber.....1012, 1015, 1045
- Paint Accessories**.....1046, 1050, 1054
- Paint Brushes**.....1046-1049
- Paint Markers**.....1142, 1442-1444
- Paint Remover**.....1039
- Paint Roller Covers**.....1049-1051
- Paint Rollers**.....1049-1051
- Paint Stencils**.....797-798
- Paint Sticks**.....1142, 1443-1444
- Paint Supplies**
 - Accessories.....1046, 1050, 1054
 - Brushes.....1046-1049
 - Cloths.....1054
 - Drop Sheets.....1054
 - Foam Rollers.....1049
 - Paint Remover.....1039
 - Paint Thinner.....1037
 - Roller Covers.....1049-1051
 - Rollers.....1049-1051
 - Sponging & Ragging.....1050
 - Wall Barriers.....1054
- Paint Thinner**.....1037
- Painting Supplies**
 - Extension Poles.....287-288, 292-294, 297-299, 302, 1048
 - Masking Tape.....1050
 - Mixers.....1046
 - Paint Guns.....1051
 - Paint Sprayers.....1042, 1051
 - Paint Trays.....1050
- Pallet Covers**.....1423
- Pallet Lifters**.....181, 184, 201
- Pallet Pullers**.....186
- Pallet Racks**.....49-51
- Pallet Servers**.....239
- Pallet Tilters**.....184
- Pallet Top Sheet**.....1423
- Pallet Trucks**.....144, 182-186

Pallets Aluminum 48 Plastic 46-48, 1423 Spill Control 704-708, 710, 713-714 Palm Sanders 1180 Panel Trucks 158-160 Panels, Bins 7 Pans, Drip 252, 680-681 Pants Arc Flash 554 Flame Resistant 554 General Protection 534 Rain 541, 551-552 Work 550, 552 Paper Corrugated 1430 Kraft 1428, 1430 Printer & Photocopier 1579 Tissue 1428 Toilet 340, 345-346 Paper Bags 1435 Paper Clamps, Hanging 1565 Paper Clips 1580 Paper Cutters 1427, 1432-1433 Paper Towel Dispensers 340-343, 1583 Paper Towels 341-344, 346 PAPP Respirators 466, 470-481, 1122, 1127 Parade / Waiter's Gloves 625 Parallel Clamps 1286-1287 Park Benches 380 Parkas 552, 555 Parking Curbs, Traffic Control 861 Parking Signs 810, 820 Particulate 685 Partitions Column Protectors 86 Enclosures 866 Fences 865 Gates 82-84, 216, 309, 866-867, 878 Guard Rails 54, 84-85, 489 Manhole Shields 489, 491 Perimeter Guards 51, 84-85, 88 Steel Mesh 51, 84-85, 88-89 Strip Curtain Doors 91-93 Parts Cleaning Bench Cans 992 Brushes 993 Dip Tanks 992 Dipping Baskets 992 Parts Washers 993, 995 Rinse Tanks 992 Wash Tanks 992 Parts Storage Carts 42 Parts Washers 993, 995 Cleaning Fluids 995 Patches, Eye 728, 730, 735 Pavement Tape 868 Pedestal Fans 1497-1499 Pencil Grinders, Air 1223 Pencil Sharpeners 1578 Pencils 729, 732-733, 1578 Grease 1142, 1445 Penetrants 5-Way 1013 Bolt Removal 1013 KB 88 1013 Multi-Purpose 1013 Water Based 1144 WD-40 1004, 1012-1013 Penlights 1512 Pennants, Traffic Control 871 Pens Office 1578 pH 1490 Perimeter Guards 51, 84-85, 88 Permanent Markers 1442, 1445, 1578 Personal Protection Dust Masks 447, 453 Ear Muffs 433-439, 549 Ear Plugs 423-429, 431 Elbow Protectors 643 Eyewear 386-408, 412, 689-697, 1120, 1310-1311 Faceshields 410-413, 557 Fingercots 600 Footwear 289, 527, 534, 631-638, 889 Forearm Protectors 528-529, 534, 643 Gloves 549, 558-559, 562-629, 644, 656, 729-735, 762, 1129-1131, 1310-1311 Headwear 414-418, 526-527 Hearing Bands 430-431 Knee Pads 639-640, 1133 Mitts 622 Respirators 447-466, 469-473, 475, 477, 479-481, 1122, 1127 Shin Guards 638 Petroleum Jelly 749 pH Meters 1490 Pharmaceutical Products Cream Dispensers 331 Hand Creams 331, 333 Hand Sanitizers 323-324, 333, 760 Insect Repellent 335, 384 Insect Sting Relief 749 Medicine 752 Petroleum Jelly 749 Skin Conditioners 333 Skin Creams 333 Sunscreen 335, 384 Phase Rotation Testers 1468 Phillips Bits 1345 Phillips Screwdrivers 1309-1312, 1338-1341, 1378, 1383, 1386 Photocopier Paper 1579 Picks 368, 1381 Picks & Hooks 1307 Pick-up Magnets 1297-1298 Picnic Tables 380 Pictograms Right-To-Know 846 WHMIS 845-846 Pillows, Spill Control 680 Pin Face Spanners 1330 Pin Punches 1309-1310, 1312, 1368-1370 Pinch Bars 1367, 1380 Pins, Push 1569 Pipe Cements 1022 Pipe Contour Markers 1116-1117 Pipe Fittings Kee Klamp 79-81 Lubrication 999-1001 Pneumatic 1228, 1240-1244, 1247 Pipe Flange Aligners 1115-1116 Pipe Markers 833-841 Pipe Taps 960, 973 Pipe Tools Clamps 1285 Contour Markers 1116-1117 Flange Aligners 1115-1116 Flaring Tools 1374 Jacks 1115 Wrenches 1309, 1372-1373, 1378 Pipe Trucks 160-161 Pipefitting Levels 1115-1117 Piping Kee Klamp 81 Pneumatic 81 Placards, TDG 851-854 Plasma Cutter Guides 1069 Plasma Cutters 1090 Plastic Bandages 729-735, 741-742, 745 Plastic Strips 734, 742 Plates Cafeteria 1583 Styrofoam 1583 Platform Ladders 127, 129-131, 135 Platform Scales 1494-1495 Platform Trucks Aluminum Deck 155-156 Dead Skids 154 Non-skid Vinyl Deck 156 Plastic Deck 156-158 Semi-Live Skids 154, 158 Steel Deck 152-153, 155, 160, 165 Structural Foam Deck 157 Wood Deck 153-154 Platforms Maintenance 141 Work 135-136, 906 Pliers Bolt Holder 1349 Chain Nose 1348 Combination Slip-Joint 1377 Convertible 1353 Crimping Die 1349, 1377 Cutting 1309-1312, 1348-1351, 1353, 1377, 1383 Lineman's 1309-1312, 1348 Locking 1288, 1309-1312, 1351-1352, 1354 Long Nose 1309-1312, 1348, 1351, 1377 MIG 1088 Needle Nose 1349, 1351 Non-Sparking 1383, 1386 Pump 1377 Retaining Ring 1353 Round Nose 364 Sets 1354 Slip Joint 1309-1312, 1348-1349 Snipe Nose 1377 Tongue & Groove 1309-1312, 1348-1349 Vise Grips 1352 Wire Stripping 1377 Plugs Electrical 1084 GFCI 1540 Plumb Bobs 1279, 1283 Plumbers Putty 1022 Plunger Cans 670 Plungers, Toilet 349 Pneumatic Fitting Lockouts 1250 Pneumatic Pipe Fittings 1228, 1240-1244, 1247 Pneumatic Piping 81 Pneumatic Tube Fittings 1239, 1248 Pneumatic Tubing 1239 Pocket Gauges 1275 Pocket Knives 1355 Pocket Levels 1115 Points, Cutting 1194 Poly Bags 1436 Poly Tubing 1430, 1437 Polyethylene Foam Tape 1416 Pools, Spill Control 694, 711 Porosity Detectors 1478 Portable Belts 928 Portable Blasters, Sandblasting 1055, 1057 Portable Blowers 359, 488, 1059-1060 Portable Buildings, Smoking Shelters 381 Portable File Belts 928 Portable Heaters 1504 Portable Scales 1492-1494 Portable Sheds 381 Posidriv Bits 1345 Positioners, Work 181 Positioning and Restraint Lanyards 508 Positive Pressure Respirators 466, 470-481, 1122, 1127 Postal Tubes 1434 Posters SDS 847 WHMIS 847 Posts Crowd Control 821, 874-880 Snow Clearing 871 Pot Brushes 26, 301 Pouch Tape 1449 Pouches Bubble 1435 Tool 523, 1387-1388, 1390-1392 Powder, Scouring 316 Power Bars 1541 Power Cable Adapters, TIG Torch 1109 Power Cables, TIG Torch 1110 Power Scrapers 1186 Power Sockets 1323, 1327 Power Strips, GFCI 1540-1542 Power Tools Balancers 203 Combo Kits 1164-1166 Demolition Hammers 1187 Dremel Tools 1192 Drill / Drivers 1156-1158, 1161, 1164, 1182 Drill Chucks 1268-1269 Drills 1158-1159, 1182-1187 Grinders 916-917, 1163, 1168-1172, 1270 Hammer Drill / Drivers 1157-1159 Heat Guns 1190-1191 Impact Wrenches 1159-1160, 1181 Knockout 1162 Nail Guns 1163, 1446 Nibblers 1173 Power Scrapers 1186 Rotary Hammers 1159, 1185-1187 Sanders 1180 Saws 872, 914, 1162-1163, 1174-1179 Screw Guns 1187 Screwdrivers 1161, 1187 Shears 1173 Power-Lock Discs 924-925, 935 PPE Battery Kit, Forklift 186 Precision Screwdrivers 1341 Prentice Drill Bits 969-970 Presses, Arbor 208 Pressure Gauges Dial 1058 Dry 1068, 1232, 1489 Liquid Filled 1489 Tire 1224 Pressure Sensitive Letters 800 Pressure Sensitive Numbers 800 Pressure Washers 374-375 Prick Punches 1370 Primers, Adhesive 1032 Print Holders 1298 Printer Paper 1579 Privacy Shower Curtain 727 Probes Temperature 1471, 1475, 1488 Test 1463 Process Gauges 1489 Propane Hoses, Welding 1068 Propane Torches 1064 Protective Wear Signs 806, 809 Provioline Solution 748 Pruners, Tree 369 Pry Bars Crate Openers 1380, 1386 Multi-Purpose 1309-1312, 1366 Nail Pullers 1366, 1380 Non-Sparking 1380 Rolling Head 1367 Tack Pullers 1340 with Handle 1367 Pry Dollies 177 Psychrometers 1475 PTC Fittings 1239 Pullers Pallet 186 Pilot Bearing 1365 Pump Lubricants 1144 Pump Pliers 1377 Pump Wrenches 1335 Pumps Air Operated 258 Cam & Groove Fittings 263 Coolant Tanks 1150 Diaphragm 258 Discharge Hoses 263 Drum 254-258 Engine-Powered 264 Grease 999-1000 Hand 254-256, 258-259 Lever 256 Lockouts 259 Machine Tool 1150 Rotary 256-258

INDEX

Submersible.....262-263, 1150
Transfer.....258, 263, 671

Punches
Aligning.....1369
Center.....1309-1310, 1312, 1368, 1370
Drift.....1309-1310, 1369-1370
Drive Pin.....1369
Pin.....1309-1310, 1312, 1368-1370
Prick.....1370
Starting.....1370

Purifiers, Air.....1500

Push Brooms.....287-290, 301

Push Pins.....1569

Push to Connect Fittings.....1239

Putty Knives.....1052
Flexible.....1052, 1382
Stiff.....1052, 1382, 1386

-Q-

Quick Clamps.....1288

Quick Couplers.....1207, 1233, 1246, 1248-1250

Quick-Connects, Welding.....1074

-R-

Rack, Carton.....1434

Racks
Bar.....53
Bicycle.....379
Bin.....8-9, 11, 39, 121
Broom & Mop.....286
Cantilever.....52
Coat.....1581
Drum.....245, 703
Gas Cylinder.....1079
Key.....1570
Pallet.....49-51
Reel.....78
Sheet.....53
Stacking.....41, 53-54, 157
Threaded Rod.....45
Tire.....78
Welding.....1078

Radiant Heaters.....1503-1505

Radiator Heaters.....1503

Radios, Two-Way.....435, 438-439, 441-442

Rafter Squares.....1280

Rag Rugs, Spill Control.....679

Rags.....338, 1054

Rail, Grab.....350

Rail Chocks.....210

Rainwear
Flame Resistant.....541-542, 548
Hoods.....541-543, 548
Jackets.....541-542, 551
Overalls.....542
Pants.....541, 551-552
Suits.....540, 543

Rakes.....367

Ramps
Twin.....214
Walk.....214

Rare Earth Magnets.....1299

Rasps
Half Round.....1305
Round.....1305

Ratchet Counters.....1483

Ratchet Straps.....1456

Ratchet Wrenches, Air.....1206, 1210

Ratcheting Wrenches.....1333-1334

Ratchets
1 1/2" Drive.....1324
1" Drive.....1324
1/2" Drive.....1315, 1317-1318, 1320-1321
1/4" Drive.....1317, 1324
3/4" Drive.....1322
3/8" Drive.....1316, 1318-1319

Razor Blades.....1052

Reamers
Adjustable.....985
Chucking.....981-985
Hand.....981
Nozzle.....1088
Taper Pin.....982

Rebar Cutters.....1361

Rebar Tie Wire Cutters.....1350

Receiving Scales.....1494

Receptacles
Electrical.....1084
Sanitary Napkin.....348-349

Reciprocating Saw Blades.....1201

Reciprocating Saws
Air.....1214
Cordless.....1163
Electric.....1179

Record Storage, Shelving.....57

Recycling Containers.....276-279, 1577

Reel Dispensers.....167

Reel Racks.....78

Reels
Cord.....1531-1532, 1537
Hose.....1076, 1234-1237, 1532
Welding.....1076

Refacers, Welding Tip.....1073

Reflectors, Traffic Control.....859

Refractometers.....1490

Refrigerators.....1584

Regulator, Calibration Gas.....484-486

Regulator/Flowmeters, Welding.....1068

Regulators
In-Line.....1232, 1256, 1261
Welding.....1064, 1066-1069

Rehydration Drinks, Sqwincher®.....648-649

Repair Kits, Hose.....377

Repellent, Insect.....335, 384

Rescue Hoist.....492

Rescue Systems.....490-492, 496, 518

Resin Fibre Discs.....922-923, 925

Respirators
Ambient Air Pump.....466, 481, 1127
Cartridges.....456, 460-464, 466, 470, 472-473, 475, 477, 480
Disposable.....447-453
Emergency Escape.....459
Filters.....452, 456-459, 461, 464, 475, 480
Fit Test Kits.....465
Full Face.....455, 458-459, 462-463, 469
Half Mask.....454-455, 458, 461-464, 469
Headgear.....473, 479, 1127
PAPR.....466, 470-481, 1122, 1127
Positive Pressure.....466, 470-481, 1122, 1127
SCBA.....469
Supplied Air.....466, 479
Welding.....450

Retaining Compounds.....1027

Retaining Ring Pliers.....1353

Retaining Rings, MIG Gun.....1095

Revolving Bins.....29

Right-To-Know Pictograms.....846

Rings, Key.....794

Rinse Tanks.....992

Risers, Dock.....215

Robertson® Screwdrivers.....1309-1312, 1338-1340

Rockers, Drum.....245

Rod / Electrode Containers.....1089, 1134

Rods, TIG.....1136-1138, 1140

Rollers
Fountain.....799
Hand.....799
Machinery.....204-205

Rolling Head Bars.....1367

Rolling Knee Dollies.....209

Rolling Ladders.....135, 137-140

Rolling Workbenches.....125

Rolls
Cartridge.....929
Spill Control.....673-678, 689-690
Surface Conditioning.....930, 933-934

Roofing Knives.....1441

Rope
Crowd Control.....879
Packaging.....1450

Rope Ends, Crowd Control.....879

Rope Grabs.....517-518, 520

Rotary Cutters.....1163

Rotary Hammer Bits.....1195-1196

Rotary Hammers.....1159, 1185-1187

Rotary Pumps.....256-258

Rotary Sanders, Air.....1211

Rotators, Drum.....239, 248

Round Files.....1302, 1304

Round Nose Pliers.....364

Round Point Shovels.....366, 1381

Round Rasps.....1305

Rubber Bands.....1423, 1580

Rubber Coating.....1012, 1015, 1045

Rubber Cutting Knives.....1371, 1441

Rubber Paint.....1012, 1015, 1045

Rubbing Alcohol.....748

Runner Matting
Carpet.....886-887
Needle Rib.....885
Pile.....885-888
Polypropylene.....885
Rubber.....888, 901, 909
Vinyl.....901

Rust Converters.....1014, 1146, 1148

Rust Preventers.....1014, 1146

Rust Removers.....1014, 1146

-S-

Safes.....1562, 1577

Safety
Anti-Skid Cleats.....872
Arm Protection.....528-529, 534, 643
Cans.....668-669
Cones.....48, 308, 1423
Cooling Clothing.....645-647
Crowd Control.....794, 821, 874-880
Ear Protection.....423-431, 433-439, 549
Ergonomic Products.....639-644, 746, 1133
Eyewear.....386-408, 412, 689-697, 1120, 1310-1311
Faceshields.....410-413, 557
Fall Protection.....141, 490-492, 494-502, 507-510, 512-520, 522-524, 560
Fire Protection.....651-656, 753
First Aid.....335, 384, 716-763
Flame Resistant Clothing.....541-542, 548
Floor Signs.....296, 308
Flooring.....872-873, 906
Foot Protection.....289, 527, 534, 631-638, 889
Gas Detectors.....482, 484-486
Hand Protection.....549, 558-559, 562-629, 644, 656, 729-735, 762, 1129-1131, 1310-1311
Headwear.....414-418, 526-527
High Visibility Clothing.....543, 545-549, 551
Hygienic Products.....325, 329, 348-349, 731, 734, 751, 758
Insect Repellent.....335, 384
Locking Systems.....654, 770, 782, 1562, 1570, 1577
Lockouts.....106, 259, 764, 768-769, 772-784, 786-790, 1250
Matting.....560, 727, 891-894, 896-897, 899-900, 902-909, 1119
Medicine.....752
Mirrors.....881-883
Oxygen Masks.....763
Padlocks.....99, 110, 764-773
Pharmaceutical.....323-324, 331, 333, 335, 384, 749, 760
Rehydration Drinks.....648-649
Respirators.....447-466, 469-473, 475, 477, 479-481, 1122, 1127
Safes.....1562, 1577
Security Seals.....794, 1451

Shin Guards.....244, 252, 266, 290, 638
Spill Control.....244, 252, 266, 290, 670, 673-687, 689-714, 760
Traffic Clothing.....543, 545-549, 551
Traffic Control.....83, 309, 545-548, 850, 858-864, 867-869, 871, 874
Whips.....856

Safety Pins.....730-735, 751

Safety Signs.....727, 806, 809, 849

Safety Tags.....786-788, 790

Salt.....364

Salt & Sand Containers.....363, 689

Salvage Drums.....689-690, 693, 697, 700-702, 713

Sandblasting Equipment
Dust Collectors.....1056
Guns.....1057, 1225
Media.....1055
Media Recyclers.....1055-1056
Portable Blasters.....1055, 1057
Suction Cabinets.....1056-1057

Sandblasting Gloves.....591

Sanders
Belt.....1180
Belt - Air.....1213, 1216-1217, 1220-1221
Hand.....1053
Orbital - Air.....1207, 1211-1212, 1218-1219
Palm.....1180
Rotary - Air.....1211

Sanding Blocks.....1053

Sanding Sponges.....933

Sandpaper.....930-932

Sanitary Napkin Dispensers.....348

Sanitary Napkin Receptacles.....348-349

Sanitary Napkins.....348

Sanitizing Solution
First Aid Instruments.....751

Saw Blades
Circular Saw.....914, 1202-1203
Combination Saw.....1203
Cut-Off.....1203
Mitre Saw.....1203
Reciprocating Saw.....1201

Sawhorses.....135

Saws
Bandsaws.....1178
Chop.....914, 1174
Circular.....872, 1162, 1177
Drywall.....1053
Framing.....872
Hacksaws.....1300-1301, 1309-1312
Hole.....1197-1198
Jig Saws.....1178
Mitre.....1175-1176
Reciprocating.....1163, 1179
Reciprocating - Air.....1214

Scaffolding.....134, 141-143

Scales, Air.....1207, 1214

Scales
Bench.....1433, 1491-1495
Counting.....1491
Crane.....203, 1496
Dial.....1494
Floor.....1496
Hanging.....203, 1493-1494, 1496
Platform.....1494-1495
Portable.....1492-1494
Receiving.....1494
Utility.....1492-1494
Weighing.....1491-1492

Scaling Chisels.....1088, 1194

Scaling Hammers.....1364

SCBA Respirators.....469

Scissors
Electrician.....1357
First Aid.....729-735, 747
General Purpose.....1356
Industrial.....1356-1357, 1442, 1580

Scoop Shovels.....1381

Scoops
Aluminum.....366, 994
Grain and Coal.....366
Litter.....282, 290, 383

Polyethylene.....	363	Seating	Packing List Envelopes.....	1449	Kevlar®.....	529
Polypropylene.....	694	Chair Caddies.....	Pallets.....	46-48, 1423	Nylon.....	528
Spill Control.....	687	Ergonomic.....	Strapping.....	1419-1422	Polypropylene.....	528, 534
Scoreboard Signs	822-823	Folding Chairs.....	Tamper Seals.....	1451	PVC.....	528-529
Scotch® Tape Dispensers	1580	Footrests.....	TDG Labels.....	855, 1448	SuperFabric®.....	529
Scotch-Brite™ Deburring Wheels		Locker Room Benches.....	Temperature Labels.....	1429	Vinyl.....	528
.....	936, 938, 1271	Office Chairs... 1546, 1548-1549, 1553-1554	Shipping & Receiving Signs	813	Welding.....	1132
Scotch-Brite™ Discs	935	Stacking Chairs.....	Shirts		Sleigh Shovels	365
Scouring Pads	292, 302, 320, 362	Swivel Stools.....	Arc Flash.....	554	Slide Hammers	1365
Scouring Powder	316	Task.....	Flame Resistant.....	554	Slings	
Scrapers		Security	General Protection.....	534	Chain.....	189
Drywall.....	1052, 1382	Carts.....	Work.....	550	Drum Lifting.....	243
Floor.....	292, 298	Gates.....	Shock Absorbing Lanyards	141, 507-510	Nylon.....	188
Non-Sparking.....	1382, 1386	Locking Systems.....	Shoe Brushes	291, 889	Polyester.....	188-189
Power.....	1186	Shoe Covers	289, 527, 889	Slip Hooks	192-193
Rubber.....	886-888	Shop Carts	7-8, 42, 73, 76-77, 161-170	Slip Joint Pliers	1309-1312, 1348-1349
Sidewalk.....	368	Lockouts.....	Shop Coats	550	Slot Drills	986-987
Spill Control.....	687	Shop Cranes	202, 208	Slot Screwdrivers	1309-1312, 1338-1341, 1378, 1383, 1386
Scratch AWL Screwdrivers	1340	Safes.....	Shop Desks	102, 126	Slotted Bits	1344-1345
Scratch Brushes	946-947, 1087	Seals.....	Shop Lifters	180, 703	Slow Moving Vehicle Signs	859
Screens		Self-Adhesive Letters	Shop Stands	207, 209	Small Parts Bins	25, 31, 39
Urinal.....	349	Self-Adhesive Numbers	Shop Sweepers	286, 358	Fiberboard.....	11
Welding.....	1118-1119	Self-Retracting Lanyards	Shop Tables	102	Small Parts Cabinets	30-34, 37-38, 42-43, 45
Screw Extractors	960, 989	Self-Retracting Life Lines	Shoring Beams	212, 1457	Small Parts Cases	36
Screw Guns	1187	Shovels		Smoke Alarm Testers	656
Screwdriver Bits		Self-Stick Bandages	Round Point.....	366, 1381	Smoke Alarms, Ionization	655
Bit Holders.....	1343	Scoop.....	1381	Smoke Ejectors	1501
Cross-Point / Phillips®.....	1345	Semi-Live Skids	Sleigh.....	365	Smoking Shelters	381
Hex.....	1344	Sensor, Gas Detectors.....	Snow.....	364-365	Snipe Nose Pliers	1377
Hex Square Drives.....	1340, 1343	Service Benches	Spill Control.....	686	Snips	
Nutsetters.....	1343	Square Point.....	365-366, 368, 1381	All Purpose.....	1357-1359
Posidriv®.....	1345	Service Writers	Shower Testers	726	Duckbill.....	1357
Slotted.....	1344-1345	Sets	Showers, Emergency	718-719	Grape & Orchid.....	1357
Square Recess.....	1344-1345	Cold Chisel.....	Shredders, Paper	1580	Metal Cutting.....	1358-1359
Torque.....	1343	Files.....	Shrink Wrap	1426	Snow Brushes	364
Torx®.....	1343-1344	Forstner Bit.....	Shrink Wrap Machines	1426	Snow Clearing Posts	871
Tri-Wing.....	1344	Nut Driver.....	Side Cutting Pliers	1349, 1351, 1377	Snow Fences	865
Screwdrivers		Pliers.....	Sidewalk Scrapers	368	Snow Flags	871
Air.....	1207, 1209, 1211, 1222	Rotary Hammer Bit.....	Signal Horns	444	Snow Shovels	364-365
Cabinet Tip.....	1309-1312, 1338-1340, 1383	Screwdriver.....	Signs		Soap	
Cordless.....	1161, 1187	Socket.....	Admittance.....	803-810, 813	Antibacterial.....	324-325, 329
Cross-Point / Phillips®.....	1309-1312, 1338-1341, 1378, 1383, 1386	Tap & Drill.....	Aisle.....	12, 48	Antimicrobial.....	326
.....	1338-1341, 1378, 1383, 1386	Wrench... 1309-1310, 1312, 1332-1334, 1337	Chemical Hazard.....	804, 808	Body Lotion.....	749
Flat Tip / Slot.....	1309-1312, 1338-1341, 1378, 1383, 1386	Shampoo	Confined Space.....	758, 804, 808	Hair and Body.....	325, 329
Multi-Tip.....	1340-1341	Sharps Collectors	CSA Standard.....	814-817	Hand.....	315, 324-329, 331-332
Precision.....	1341	Shears	Direction and Exit.....	807, 810-811	Soap Dispensers	315, 324-326, 330-333
Scratch AWL.....	1340	Air.....	Ear Protection.....	806, 809	Soapstone	1143
Sets.....	1338-1341, 1383	Fabric.....	Electrical Hazard.....	804-805, 808	Socket Accessories	1314-1324, 1327
Square / Robertson®.....	1309-1312, 1338-1340	Exit.....	1521	Socket Sets	
Torque.....	1329	Power.....	Eye Protection.....	806, 809	Hex Bit.....	1315
Torx®.....	1339, 1341	Sheathing Tape	Fall Protection.....	806	Impact.....	1325-1326
Scribe Pens	1212, 1223	Fire.....	653, 807, 810, 812, 817, 822	Standard.....	1309-1310, 1312-1315
Scrub Brushes	26, 291, 300, 946	Sheet Holders	First Aid.....	727, 805, 809, 812	Sockets	
Scrubbers, Hand	292, 302, 320	Sheet Protectors	Floor.....	296, 308, 813	Hex Bit.....	1316
SDS		Sheets, Burn Care	Hazardous Materials.....	808	Impact.....	1323-1324, 1327
Binders.....	849	Shelf Bins	Machinery & Operations.....	804-805, 809	Non-Sparking.....	1385
Information Centre.....	848-849	Maintenance.....	808-809, 813	Power.....	1323, 1327
Poster.....	847	Shelf Carts	No Smoking.....	806-808, 810	Standard.....	1314-1322
Sealant, Spill Control	683, 694	Parking.....	810, 820	Socks, Spill Control	680
Sealant Tape	1027-1028, 1416	Shelters, Spill Control	Protective Wear.....	806, 809	Soft Face Hammers	1363
Sealants		Shelves, Washroom	Safety.....	727, 806, 809, 849	Solder	1140
Flange.....	1026	Shelving, Drawer Insert	Scoreboard.....	822-823	Soldering Guns	1080-1082
Foam.....	1023	Shelving Units	Shipping & Receiving.....	813	Soldering Irons	1080-1082
Gaskets.....	1025-1026	Bin.....	Slow Moving Vehicle.....	859	Soldering Pads	1118
Retaining Compounds.....	1027	Chrome.....	TDG.....	851-854	Soldering Stations	1082
Silicone.....	1025	Traffic.....	210, 807, 810, 812, 820-821, 851, 857-859	Soldering Tips	1064
Teflon® Tape.....	1027-1028, 1416	Plastic.....	Washroom.....	813	Solutions, Lens Cleaning	409
Thread.....	1026	Stainless Steel.....	Silicone Lubricants	1008, 1010	Solvent Free Degreasers	313, 1002-1003
Threadlockers.....	1020, 1027-1028	Steel.....	Silver & Deming Drill Bits	954	Sorbents	
Sealers, Floor	1019	Steel Wire.....	Single Ladders	127, 132-133	Absorbents.....	684-685, 691-692
Sealing Press, Security Seals	794	Widespan.....	Single-Gas Detectors	482, 485	Booms.....	679
Sealing Spatula	1052	Shields	Skid Lifts	181	Pads.....	673-678, 680
Seals		CPR.....	Skin Conditioners	333	Particulate.....	685
Sealing Press.....	794	Face.....	Skin Creams	333	Pillows.....	680
Security.....	794, 1451	Manhole.....	Sky Hooks	199	Rag Rugs.....	679
Steel.....	1419, 1421	Shims	Sledge Hammers		Rolls.....	673-678, 689-690
Tamper.....	1451	Double Faced.....	369, 1366	Socks.....	680
Seamers, HVAC	1359	Shin Guards, Plastic	Non-Sparking.....	369, 1365, 1380	Sweeping Compounds.....	290
Seat Cover, Automotive	280, 546	Shipping	Sleeves		Sorters, Mail	1566
		Benches.....	Canvas.....	528		
		Cargo Nets.....	Cotton.....	528-529		
		Handling Labels.....				
		Jack Bars.....				
		Logistic Tracks.....				
		Mailers.....				
		Moving Blankets.....				

INDEX

Sound Level Meters		Stainless Steel Cleaners316, 319, 1004	Revolving Bins.....29	Surface Conditioning Belts937
Digital.....440, 1480		Stairway Ladders140	Safety Cans.....668-669	Surface Conditioning Discs934-936, 938
Integral Probe.....440, 1480-1481		Stamps, Hand795-796, 1117	Salt & Sand Containers.....363, 689	Surface Conditioning Pads302, 933
Spade Handle Drills1183-1184		Stands	Shelf Bins.....13-15, 25	Surface Conditioning Rolls930, 933-934
Spades		Automotive.....207, 209	Shelving Units.....11, 17, 55-58, 61-67,	Surface Mount Thermometers1473
Drain.....366		Engine.....208	70-75, 78, 99	Surge Protectors1540-1541
Garden.....366		Equipment.....170	Small Parts Bins.....11, 25, 31, 39	Surge Suppressors1540, 1542
Spading Forks367		Garbage Bag.....383	Small Parts Cabinets.....	Surgical Tape729, 744
Spanner Wrenches1330		Gas Cylinder.....1079	30-34, 37-38, 42-43, 45	Suspenders1389
Spanners, Pin Face1330		Monitor.....1577	Small Parts Cases.....36	Sweatbands420, 1133
Spats, Welding1132		Work.....209, 225	Stacking Bins.....	Sweeper Magnets286
Spatula, Sealing1052		Staple Removers, Packaging1447	4-6, 13-17, 21, 26, 40-41	Sweepers286, 358
Spatulas, Non-Sparking1382		Staplers, Packaging1446-1447	Stacking Racks.....41, 53-54, 157	Sweeping Compounds290
Speed Bumps, Traffic Control860		Staples	Static Bags.....1435	Switch Brooms290
Spill Control		Carton Staplers.....1446-1447	Steel Bins.....40-41, 44-45	Swivel Connectors1219, 1250
Berms.....681, 711-712, 714		Office Staplers.....1446	Tanks.....27	Swivel Stools1554
Brooms.....687		Pneumatic Stapler.....1447	Threaded Rod Racks.....45	Synthetic Greases1018
Containers.....709-710		Starcarts™.....174-175	Tire Racks.....78	
Drain Protectors.....682		Starting Punches1370	Tool Aprons.....1391	
Drain Seals.....681-683, 689-693		Static Bags1435	Tool Bags.....1391-1393, 1464	
Drip Cans.....670		Stations	Tool Belts.....1389	
Drip Pans.....252, 680-681		Docking.....482-483, 485-486	Tool Boxes.....1309-1311, 1393-1394	
Drum Carts.....701		Lens Cleaning.....409	Tool Cabinets.....	
Drum Dollies.....244, 266, 701-702		Stem Thermometers1473	103, 1309, 1312, 1395-1400	
Drum Racks.....703		Stencil Inks799	Tool Carts.....123-125, 1395, 1397, 1400	
Drum trays.....681, 703, 711, 713		Stencils	Tool Chests.....	
Funnels.....699		Paint.....798	1309-1310, 1394-1399, 1402-1403	
Kits.....689-698, 760		Paint & Ink.....797	Tool Holders.....1387-1388, 1392	
Leak Diverters.....683		Step Cans269-270, 761	Tool Pouches.....523, 1387-1388, 1390-1392	
Leak Seal.....683		Step Ladder Hand Truck1581	Transfer Boxes.....19	
Neutralizers.....686, 697		Stepladders127-128, 134-135	Van and Truck Equipment.....1407	
Overpack.....		Stepstands, Steel135-137	Straight Blade Knives1382, 1386	
689-690, 693, 697, 700-702, 713		Stepstools	Straight Ladders127, 132-133	
Pallets.....704-708, 710, 713-714		Fiberglass.....134	Straight Line Clamps1290, 1292	
Pools.....694, 711		Polyethylene.....136, 1549	Straight Wrenches1373	
Salvage Drums.....689-690, 693, 697,		Stethoscopes756	Strainers, Drum & Pail235	
700-702, 713		Stick Electrodes1136-1137, 1139	Strap Wrenches1372	
Scoops.....687		Stick-On Discs926-927	Strapping	
Scrapers.....687		Sting Relief, Insect749	Buckles.....1420-1422	
Sealant.....683, 694		Stirring Sticks1583	Dispensers.....1420, 1422	
Shelters.....708		Stock1274	Machines & Tools.....1419-1422	
Shovels.....686		Stock Picking Carts165	Poly.....1421-1422	
Sorbents.....290, 673-680, 684-685, 689-692		Stock Trucks166	Seals.....1419, 1421	
Spinal Backboard755		Stools	Stainless Steel.....1420	
Spiral Bands929		Swivel.....1554	Steel.....1419-1420	
Splints731, 734, 754		Task.....209, 1134, 1550-1554	Tape.....1412	
Finger.....754		Stop & Go Lights220	Straps, Moving150, 246, 1454-1456	
Leg.....731, 734, 754		Stop Sleeves194	Straws1583	
Sponges, Sanding933		Stopwatches645, 1475, 1483	Stretch Wrap	
Spoons, Cafeteria1583		Storage	Banding Film.....1425	
Spot Lights187, 1516, 1518		Bar Racks.....53	Blown.....1424	
Spotter, Drum247		Bin Racks.....8-9, 11, 39, 121	Cast.....1424, 1426	
Spray Adhesives1036, 1418		Bin Shelves.....6, 11, 15-17, 21, 59-60	Clear.....1424-1425	
Spray Bandages742		Bottles.....28	Coloured.....1424	
Spray Lubricants1008-1013, 1018, 1543		Cabinet Tables.....124	Machine.....1426	
Sprayers		Cabinets.....9-10, 35, 94-103, 381,	Opaque.....1424	
Lawn & Garden.....320, 371-373		658, 660-667, 1561, 1563	Stretch Wrap Dispensers1424-1426	
Paint.....1042, 1051		Cantilever Racks.....52	Stretchers	
Trigger.....302, 320		Carton Rack.....1434	Folding.....754	
Spreaders, Adhesive1053		Collapsible Containers.....44-45	Wire Basket.....755	
Spring Clamps1288		Dispenser Bottles.....672	Striking Face Wrenches1331	
Sprinklers, Garden Hose376		Distribution Containers.....	String Lights1528	
Spud Wrenches1372		18-20, 22-24, 1564	Strip Curtain Doors91-93	
Square Files1304		Drawers.....37	Strip Magnets1298	
Square Point Shovels365-366, 368, 1381		Equipment Cases.....1461, 1464-1465, 1471	Stripping Machines1039-1040	
Square Recess Bits1344-1345		ESD Bins.....25	Strippers, Wire1351	
Square Screwdrivers1309-1312, 1338-1340		Food Handling Containers.....175	Stripping Pads362	
Squares		Gas Cans.....671-672	Stroboscopes1483	
Bevels.....1280-1281		Gas Cylinder Brackets.....1079	Structural Adhesives1032-1034	
Carpenter.....1280		Gas Cylinder Cabinets.....1077	Structural Wrenches1330	
Drywall.....1280		Gas Cylinder Racks.....1079	Structures	
Rafter.....1280		Gas Cylinder Stands.....1079	Bollards.....54, 85, 87, 865	
Try.....1280		Horizontal Sheet Rack.....53	Portable Buildings.....381	
Welding.....1086		Jars.....28	Portable Sheds.....381	
Squeegees296-299, 301, 687		Jobsite Boxes.....36, 1394, 1401-1407	Tents.....382, 489, 647	
Squinch®648-649		Lockers.....104-110	Submersible Pumps262-263, 1150	
Stackers180, 703		Mobile Bins.....6	Suction Cabinets1056-1057	
Drum.....242		Nesting Bins.....18-19, 26	Suggestion Boxes1581	
Stacking Bins4-6, 13-17, 21, 26, 40-41		Oily Waste Cans.....670-671	Suits, Rain540, 543	
Stacking Chairs1555		Pallet Racks.....49-51	Sunscreen335, 384	
Stacking Dollies20		Paper Bags.....1435	Supermills987	
Stacking Racks41, 53-54, 157		Plunger Cans.....670	Supplied Air Respirators466, 479	
Stacking Tables1556-1557		Poly Containers.....27, 234, 671	Support Bandages731-732, 746	



T Squares, Drywall1280
Table Caddies1557
Tables
Cabinet.....124
Changing.....348
Folding.....382, 1557
Lift.....178-179, 181, 184
Picnic.....380
Shop.....102
Stacking.....1556-1557
Work.....120, 1556, 1561
Tachometers1482
Tags
Accident Prevention.....786-788, 790
Blank.....791-793, 1448
Brass.....793
Caution.....790
Danger.....790
Key.....1570
Lockout.....786-790
Magnetic.....12
Numbered.....793
Safety.....786-788, 790
Tally Counters1483
Tamper Proof Torque Mark1342
Tamper Seals1451
Tampers348
Tanks
Coolant.....1150
Dip.....992
Rinse.....992
Storage.....27
Wash.....992
Tap & Drill Sets973
Tap Wrenches960, 977
Tap
Aisle Marking.....869-870
Aluminum Foil.....1020, 1415
Anti-Skid.....872-873
Bag Sealing.....1436
Barricade.....868
Box Sealing.....1410-1411, 1413, 1429
Conspicuity.....850
Double Sided.....1416
Duct.....1415
Electrical.....1417, 1544
Filament.....1412
First Aid.....729, 744
Flagging.....869
Glow in the Dark.....811, 870, 872-873
Gummed.....1413
Masking.....1414
Measuring.....1276-1279, 1309-1312
Office.....1580
Painter's Masking.....1050
Pavement.....868
Polyethylene Foam.....1416
Pouch.....1449
Sheathing.....1437
Strapping.....1412
Surgical.....729, 744

Teflon®.....1027-1028, 1416
 Vinyl..... 829, 1416

Tape Dispensers
 Aisle Marking Tape.....868
 Box Sealing Tape..... 1411, 1429
 Filament Tape.....1411-1413
 Gummed Tape.....1411, 1413
 Office..... 1580
 Two-Way Tape.....1416

Taper Pin Reamers.....982

Tapping Compounds.....1149

Taps
 Hand.....956-960, 974-975, 977, 988
 Machine..... 976
 Pipe.....960, 973

Tarpaulins.....379, 1453

Task Chairs.....1546, 1551

Task Lights.....1523, 1529-1530

Task Seating.....209, 1134, 1546, 1550-1554

Task Stools.....209, 1134, 1550-1554

TDG Labels.....855, 1448

TDG Placards.....851-854

TDS Meters.....1490

Technicians' Tools.....1309-1312, 1378-1379

Tees, Pipe Thread.....1240-1241, 1244

Teflon® Tape.....1027-1028, 1416

Telescopic Lights.....1528

Temperature Crayons.....1142, 1445

Temperature Labels.....1429

Temperature Probes.....1471, 1475, 1488

Temperature Recorders.....1476

Tennis Elbow Braces.....643

Tensabarriers.....821, 874-880

Tent Heaters.....489

Tents, Work.....382, 489, 647

Test Leads.....1463

Test Probes.....1463

Test Weights.....1496

Testers
 Circuit.....1461, 1539
 Hardness.....1479
 Insulation.....1467
 Motor Rotation.....1468
 Multi-Function.....1462
 Phase Rotation.....1468
 Shower.....726
 Smoke Alarm.....656
 Voltage.....1462, 1543

Tethering, Hard Hats.....420, 522, 524

Thermal Cameras.....1470

Thermocouple Probes.....1471

Thermocouple Thermometers
1429, 1471, 1474-1475

Thermo-Hygrometers.....1474, 1476

Thermometer / Hygrometers
645, 1472, 1474-1476

Thermometers
 Bi-Metal.....1473
 Cooking.....1471, 1473
 Digital.....1472-1473
 Hygrometers.....645, 1472, 1474-1476
 Indoor / Outdoor.....1472
 Infrared.....1469-1470
 Oral.....756
 Stem.....1473
 Surface Mount.....1473
 Temperature Crayons.....1142, 1445
 Thermocouple.....1429, 1471, 1474-1475

Thermostatic Mixing Valves.....721

Thickness Gauges.....1478-1479

Thimbles.....194

Thread Repair, Files.....1307

Thread Sealants.....1026

Threaded Rod Racks.....45

Threadlockers.....1020, 1027-1028

Three Square Files.....1304-1305

Thumb Tacks.....1569

Tie-Back Lanyards.....509-510

Tie-Downs.....683, 1455-1457

Ties, Cable.....793-794, 1435, 1452

TIG Rods.....1136-1138, 1140

TIG Torches.....1091, 1101, 1103-1105

TIG Welders.....1091, 1113

Tilt Trucks.....172-173

Tilters
 Drum.....239-240, 254
 Engine.....208

Tilting Vises.....1295-1296

Time Clocks.....1575

Timers
 Digital.....1483
 Mechanical.....378

Tip Cleaners.....1073

Tip Refacers.....1073

Tipppers, Pail.....245

Tips
 Cutting.....1065, 1070-1072
 Heating.....1072
 Soldering & Brazing.....1064

Tire Bags.....280

Tire Inflator Gauges.....1224

Tire Pressure Gauges.....1224

Tire Racks.....78

Tissue Paper.....1428

Tissues, Lens Cleaning.....409

Toe Guards.....637

Toggle Clamps.....1290-1291

Toilet Augers.....1375

Toilet Auto Flush Adapter.....350

Toilet Bowl Brushes.....349

Toilet Bowl Cleaners.....314

Toilet Paper.....340, 345-346

Toilet Paper Dispensers.....345-347

Toilet Plungers.....349

Toilet Seat Cover Dispensers.....348

Toilet Seat Covers.....348

Tongue & Groove Pliers
1309-1312, 1348-1349

Tongue Depressors.....734, 747

Tool Balancers.....203

Tool Holders
 ER Collet Chucks.....1269
 Turning Tools.....986

Tool Kit, Welder's.....1134

Tool Kits, Non-Sparking.....1386

Tool Lanyards.....522-524

Tool Storage
 Aprons.....1391
 Bags.....1391-1393, 1464
 Belts.....1389
 Boxes.....1309-1311, 1393-1394
 Cabinets.....103, 1309, 1312, 1395-1400
 Carts.....123-125, 1395, 1397, 1400
 Chests.....1309-1310, 1394-1399, 1402-1403
 Holders.....1387-1388, 1392
 Jobsite Boxes.....36, 1394, 1401-1407
 Pouches.....523, 1387-1388, 1390-1392

Tops, Drum.....236, 670, 699

Toque, High Visibility.....549

Torch Handles.....1065

Torch Kits, Welding.....1064, 1109

Torches
 Air (Gas) Cooled.....1101, 1103-1104
 Butane.....1080, 1083
 Cutting.....1065
 Gas.....1064
 Gouging.....1087
 Propane.....1064
 Water Cooled.....1091, 1103-1105

Torpedo Levels.....1281

Torque Bits.....1343

Torque Meters.....1329

Torque Multipliers.....1328

Torque Paste.....1342

Torque Screwdrivers.....1329

Torque Wrenches.....1328

Torx® Bits.....1343-1344

Torx® Screwdrivers.....1339, 1341

Towellettes, Benzalkonium.....729-735, 748

Towellettes, Lens Cleaning.....409, 465, 760

Towels
 Cooling.....645-646
 Hand.....334, 340-344, 384, 1005, 1583
 Paper.....341-344, 346

Tracks, Logistic.....212, 1457

Trades Carts.....169

Traffic Control
 Banners.....859
 Barricade Tape.....868
 Barricades.....83, 309, 867, 874
 Channelizers.....864
 Cones.....862-863
 Delineators.....863-864
 Flagging Tape.....869
 Flags.....858
 Flares.....859
 Harnesses.....548
 Parking Curbs.....861
 Pennants.....871
 Reflectors.....548, 850, 859
 Speed Bumps.....860
 Vests.....545-546

Traffic Safety Clothing
 Hat/Toque.....549
 Jackets.....547-548
 Overall.....543
 Pants.....548, 551
 Parkas.....547
 Rain Jackets.....543
 Rain Suits.....543
 Sweatshirts.....547
 T-Shirts.....547
 Vests.....545-547

Traffic Signs.....210, 807, 810, 812,
 820-821, 851, 857-859

Traffic Wands.....1509

Traffic Cone Bars.....863

Trailer Jacks.....212

Trailer Winches.....195

Transfer Boxes.....19

Transfer Pumps.....258, 263, 671

Transparent Bandages.....741

Trash Cans.....169, 266-275, 349-350,
 383, 761, 1577

Trays
 Boot.....889
 Drum.....681, 703, 711, 713
 Filing.....1577
 Paint.....1050
 Tree Pruners.....369

Tree Trimmers.....369

Trestle Stands.....209

Trestle Stepladders.....129-131

Triangular Bandages.....729-735, 747

Triangular Files.....1304-1305

Tricycles.....161

Trigger Sprayers.....302, 320

Triggers, MIG Gun.....1095

Trimmers, Tree.....369

Tripods, Fall Protection.....491-492

Tri-Wing Bits.....1344

Trolleys, Beam.....190, 519

Trowels, Drywall.....1053

Truck Mounted Cranes.....202

Trucks
 Appliance.....150, 1454
 Box.....166, 172-175
 Drum.....246-247
 Gas Cylinder.....1078
 Hand.....144-146, 148-151, 1454, 1554
 Ironer.....303
 Ladder.....134
 Linen.....303
 Pallet.....144, 182-186
 Panel.....158-160
 Pipe.....160-161
 Platform.....152-158, 160, 165
 Stock.....166
 Tilt.....172-173

Try Squares.....1280

Tube Brushes.....945

Tube Fittings, Pneumatic.....1239, 1248

Tubes
 Conductor.....1096
 Postal.....1434

Tube Fittings, Pneumatic.....1239

Tubing Cutters.....1374

Tumblers, Pail.....248

Tungsten Electrode Grinders.....1113-1114

Tungsten Electrodes.....1114

Turf Edgers.....368

Turntables, Pallet.....181

Turpentine.....1037

Tweezers, First Aid.....729-735, 751

Twin Ramps.....214

Twine, Packaging.....1450

Two-Way Radios.....435, 438-439, 441-442

Two-Way Tape Dispensers.....1416



Umbrellas, Welding.....1118

Undershirts.....552

Undershirts.....552

Uppers, Drum.....250

Upright Protectors.....54, 85

UPS Systems.....1542

Urinal Blocks.....349

Urinal Screens.....349

Utility Carts.....76, 166, 168-170

Utility Knives.....1382, 1440-1442

Utility Scales.....1492-1494



Vacuum Cups.....196-197

Vacuums
 Accessories.....
352-353, 357-359, 361, 688, 1225
 Back Pack.....357
 Portable.....358
 Upright.....360
 Wet / Dry.....352-357, 360-361, 688

Valves
 Adjusting.....1232
 Ball.....1231
 Butterfly.....1231
 Drum.....252
 Gate.....252
 Safety.....1232, 1257
 Water Mixing.....721

Van and Truck Equipment.....1407

Vane Anemometers.....1486

Vapor Barrier.....1437

Vehicle Brushes.....292

Vents, Drum.....251

Vertical Life Lines.....517, 520

Vertical Sheet Rack.....53

Vests
 Cooling.....646-647
 Reflective.....545-546
 Traffic Control.....545-546
 Winter.....552

Vibration Isolation
 Anti-Vibration Pads.....1272
 Cupmounts.....1272
 Isolators.....1272
 Leveling Mounts.....1272

Vibration Meters.....1484

Vinyl Tape.....829, 1416

Vise Grips.....1352

Vises
 Angle.....1295
 Bench.....1293-1294
 Drill Press.....1295-1296
 Machine.....1295
 Tilting.....1295-1296

Visors.....410-413, 557

Voltage Testers.....1462, 1543

-W-

Wagons.....154, 157, 370
Waiter's / Parade Gloves.....625
Walkie-Talkies.....435, 438-439, 441-442
Walkramps.....214
Wall Barrier, Temporary.....1054
Wall Clocks.....1575
Wall Heaters.....1504
Wall Mounted Fans.....1497-1499
Wall Plates, Crowd Control.....875, 877
Wallet Cards, WHMIS.....846
Wands, Marking.....1038-1040
Warmers, Hand.....629
Warning Lights.....222-223, 863, 866
Warning Systems, Horns.....221
Wash Tanks.....992
Washroom Cleaners
 Disinfectants.....313-314, 318, 759-760
 Toilet Bowl.....314
 Urinal.....349
Washroom Products
 Air Fresheners.....314, 321-322
 Changing Tables.....348
 Clothes Hooks.....350
 Drain Augers.....1375
 Facial Tissue.....344
 Faucets.....350
 Grab Bar.....350
 Hand Dryers.....351
 Mirrors.....350
 Paper Towel Dispensers.....340-343, 1583
 Paper Towels.....341-344, 346
 Shelves.....350
 Toilet Augers.....1375
 Toilet Auto Flush Adapter.....350
 Toilet Paper.....340, 345-346
 Toilet Paper Dispensers.....345-347
 Toilet Plungers.....349
 Toilet Seat Cover Dispensers.....348
 Toilet Seat Covers.....348
 Urinal Screens.....349
Washroom Sign.....813
Waste Container Caddy.....266
Waste Container Dollies.....266, 271, 276-277
Wastebaskets.....169, 267-272, 383, 1577
Water Brooms.....377
Water Cooled Torches.....1091, 1103-1105
Water Coolers.....650
Water Filters.....1585-1586
Water Fountains.....1585-1586
Water Heater, Eyewash.....721
Water Hoses, Welding.....1110
Water Preservatives.....722-723, 725
WD-40®.....1004, 1012-1013
Wedge, Non-Sparking.....1381
Weighting Scales.....1491-1492
Weights, Test.....1496
Welder's Tool Kit.....1134
Welding Clothing
 Aprons.....1132
 Beanies.....1125, 1133
 Bibs.....1132
 Chaps.....1132
 Jackets.....1132
 Sleeves.....1132
 Spats.....1132
Welding Equipment
 ADF Filters.....1121-1122, 1124-1126, 1128
 Burning Guides.....1117
 Butane Torches.....1080, 1083
 Carts.....1078
 Chest Protectors.....1125
 Chipping Hammers.....1087-1088
 Connectors.....1084-1085
 Cutting Tips.....1065, 1070-1072
 Cutting Torches.....1065
 Electrode Holders.....1084
 Electrode Ovens.....1089
 Filter Plates.....1126, 1128
 Flint Lighters.....1073
 Flowmeters.....1068
 Fume Filters.....1058-1059
 Gas Cylinder Wrenches.....1073
 Gas Torches.....1064
 Gels.....1145
 Gouging Torches.....1087
 Hand Shields.....1123
 Heating Tips.....1072
 Helmets.....481, 1121-1127
 Magnifier Plates.....1126, 1128
 MIG Guns.....1094-1098
 MIG Pliers.....1088
 MIG Welders.....1092-1093
 Neck Protectors.....1125
 Nozzle Reamers.....1088
 Outfits.....1062-1064
 Plasma Cutters.....1069, 1090
 Propane Torches.....1064
 Quick-Connects.....1074
 Racks.....1078
 Reels.....1076
 Regulator/Flowmeters.....1068
 Regulators.....1064, 1066-1069
 Respirators.....450
 Screens.....1118-1119
 Soldering & Brazing Tips.....1064
 Soldering Guns.....1080-1082
 Soldering Irons.....1080-1082
 Soldering Stations.....1082
 TIG Torches.....1091, 1101, 1103-1110
 TIG Welders.....1091, 1113
 Tip Cleaners.....1073
 Tip Refacers.....1073
 Torch Handles.....1065
 Torch Kits.....1064, 1109
 Tungsten Electrode Grinders.....1113-1114
 Umbrellas.....1118
 Weld Fillet Gauges.....1073
Welding Harnesses.....496, 500
Welding Lanyards.....510
Welding Supplies
 Arrestors.....1074
 Blankets.....1118
 Brazing Alloys.....1139
 Cable Lugs.....1085
 Cable Protectors.....1110
 Cables.....1085
 Developers.....1020, 1144
 Fault Detectors.....1012, 1020, 1144, 1148
 Flints.....1073
 Flux.....1141, 1145
 Gouging Electrodes.....1087
 Ground Clamps.....1086
 Hose Fittings.....1074
 Hoses.....1068, 1075, 1110
 Matting.....904, 1119
 MIG Wire.....1135, 1137-1138
 Pads.....1118
 Rod / Electrode Containers.....1089, 1134
 Solder.....1140
 Stick Electrodes.....1136-1137, 1139
 TIG Rods.....1136-1138, 1140
 Tungsten Electrodes.....1114
Weld-On Hinges.....1088
Wet Mops.....292-295, 304-306
Wheel Brushes.....941-944, 1271
Wheel Chair.....758
Wheel Chocks.....210-211
Wheel Dollies.....177, 208
Wheel Locks.....782
Wheel Risers.....215
Wheelbarrows.....172, 370
Wheels.....144-145, 148, 154, 232-233, 246
 Buffing.....937
 Crimped Filament.....912-913
 Cut & Polish.....938
 Cut-Off.....912-916
 Deburring.....936, 938, 1271
 Finishing.....938
 Flap.....919-920, 937
 Grinding.....912-917, 1271
 Measuring.....1278, 1482, 1484
Whips
 Hose.....1250
 Safety.....856
White Glue.....1029
White Lithium Greases.....1018
White Lithium Lubricants.....1018
Whiteboard Dry Erase Wipes.....1569
Whiteboard Markers.....823, 1569
Whiteboards.....1569
Whitewash Brushes.....292
WHMIS
 Information Charts.....847
 Labels.....846
 Pictograms.....845-846
 Posters.....847
 Wallet Cards.....846
Winches
 Hand.....195
 Personal.....492
Windex®.....315
Window Brushes.....292
Window Washers.....299
Windshield De-Icer.....1015
Windssocks.....871
Winter Boots.....635-636
Winter Clothing
 Coats.....552
 Jackets.....552
 Parkas.....552, 555
 Vests.....552
Winter Lined Gloves.....549, 571, 593,
 604-605, 609, 611, 613-618, 626
Winter Liners.....418, 553
Wipes.....316, 318, 332, 334, 336-339,
 384, 465, 759-760, 1054
 Dry Erase Whiteboard.....1569
Wipes Dispensers.....334, 336, 338-340
Wire, MIG.....1135, 1137-1138
Wire Basket Stretchers.....755
Wire Cleaner.....1143
Wire Connectors.....1543
Wire Measurers.....1484
Wire Mesh Bins.....4
Wire Pulling Lubricants.....1012, 1543
Wire Spool Carts.....167
Wire Strippers.....1351
Wire Stripping Pliers.....1377
Wires, Bonding & Grounding.....252-253, 665
Wood Fillers.....1022
Wood Glue.....1029
Woodworking Chisels.....1367
Woodworking Machines, Bandsaws.....1178
Work Boots.....632-633
Work Clothing
 Aprons.....530-531
 Balaclavas.....553
 Coveralls.....550, 554
 Hard Hat Liners.....418, 553
 Lab Coats.....550
 Pants.....550, 552
 Shirts.....550
 Shop Coats.....550
 Sweatbands.....420, 1133
 Undergarments.....552
Work Lights.....1162, 1520, 1525-1528, 1530
Work Platforms.....135-136, 906
Work Positioners.....181
Work Stands.....209, 225
Work Tables.....120, 1556, 1561
Work Tents.....382, 489, 647
Workbenches.....103, 112-123, 125, 1432
 Accessories.....118-119
 Folding.....121
Workstations.....118-119
 Accessories.....118-119
 Computer.....1559-1560
 Mail.....1566
 Office.....1567
 Open Wire.....118
 Packaging.....1433
 Service Benches.....123-125
 Shipping.....1433
 Shop.....102, 126
 Work Tables.....120, 1556, 1561
 Workbenches.....103, 112-123, 125, 1432
Worm Gear Winches.....195
Wound Closures.....742, 745
Wrap
 Bubble.....1427
 Shrink.....1426
 Stretch.....1424-1426
Wraps, Cooling.....645, 647
Wrecking Bars.....1366
Wrenches
 Adjustable.....1309-1312, 1330, 1332
 Angle.....1335
 Box.....1331, 1336
 Bung.....250
 Chain.....1372
 Combination.....1309-1310, 1312, 1331-1334, 1337
 Compound Leverage.....1372
 Drum.....250
 End.....1373
 Flare Nut.....1335-1336
 Flex Head.....1334-1335
 Gas Cylinder.....1073
 Gear.....1333-1334, 1337
 Hex.....1372, 1378
 Impact.....1159-1160, 1181
 Impact - Air.....1205, 1208, 1210, 1214, 1222
 Non-Sparking.....1384-1386
 Offset.....1373
 Open End.....1335
 Pipe.....1309, 1372-1373, 1378
 Pump.....1335
 Ratchet - Air.....1206, 1210
 Ratcheting.....1333-1334
 Spanner.....1330
 Spud.....1372
 Straight.....1373
 Strap.....1372
 Striking Face.....1331
 Structural.....1330
 Tap.....960, 977
 Torque.....1328
Wringers.....294, 306-307
Wrist Supports.....643-644, 746

-Y-

Y Connections
 Hose.....1074