



IS INFLATION SQUEEZING YOU DRY?

**PREMIUM PRODUCT
PRICED AT NON-
PREMIUM LEVEL**

IN STOCK



**10 YEAR
WARRANTY**

8" GS810 Precision Milling Machine Vise

- Matched bed height of 3.310" ± 0.0005 ".
- The swivel base is graduated 360°.
- Four jaw plate positions allow extra capacity with the jaw plates in the outside position.
- The movable jaw does not lift off the bed.
- Integral key and large fasteners reduce deflection by 50%.
- Chip cover protects the leadscrew.

6" GS160G Precision Milling Machine Vise

- Bearing pack engineered to deliver a highly stable workholding system.
- Brush seal design keeps debris from penetrating the nut.
- 4-bolt design of the fixed jaw enables stable clamping.
- Pull-type design and spindle nut that does not protrude past the body.
- Spherical Segment creates an all directional alignment.

4" GS100G Precision Milling Machine Vise



327300

327320

327319



8", 6" & 4" Precision Milling Machine Vises

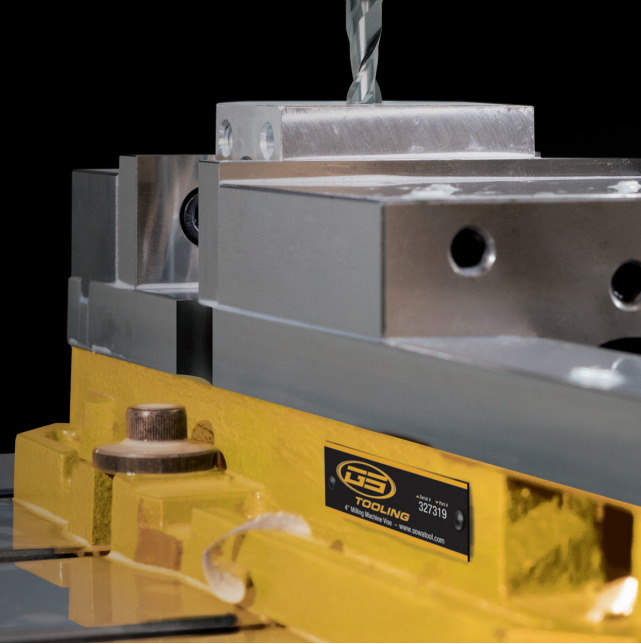

**10 YEAR
WARRANTY**

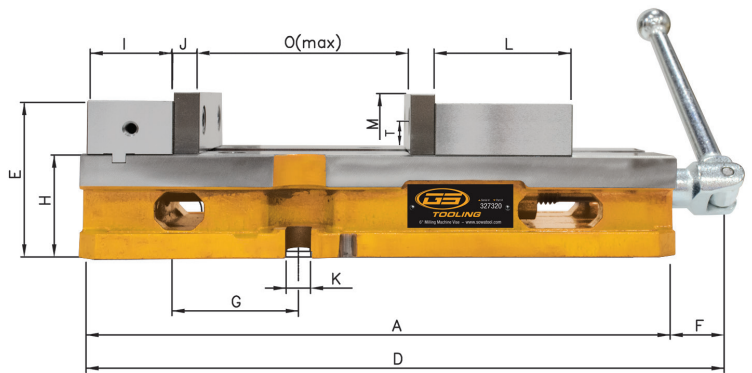
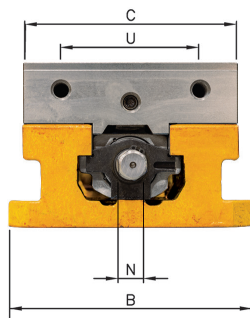

Compare the specs of GS Tooling vises with your current vises:

Model	A	B	C	D	E	F	G	H	I	J	K	L	M	N	O	T	U	Weight	Code No.
4" GS100G	12.5	5	4	13.7	3.37	1.14	2.56	2.25	1.75	0.55	0.5	3.1	1.24	0.55	6.5	0.69	2.5	30.86lbs	327319
6" GS160G	16.8	7.3	6	18.4	4.37	1.54	3.56	2.875	2.31	0.725	0.725	4	1.75	0.75	9.1	0.94	3.875	68.34lbs	327320
8" GS810	21.8	11.62	8	-	5.55	-	-	3.310	-	-	-	-	2.25	-	10.0	-	-	158lbs	327300



GSV60
6" Versatile Machine Vise
382620



GS675
6" Precision Milling Machine Vise
327275M

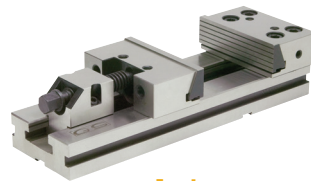

Plain Base
4" - 12" Vises
20 Product Numbers to choose from



Double Clamp
4" & 6" Vises
382610 & 382600

These premium products are priced at non-premium prices and delivers significant value for your money.

Quality

		COMPETITOR

Price



Sowa Tool & Machine Co. Ltd.

Order online at www.SowaTool.ca, email sales@sowatool.com or call 1-800-265-8221.