

**SOWA**<sup>®</sup>

TOOLING  
YOUR  
WORLD.

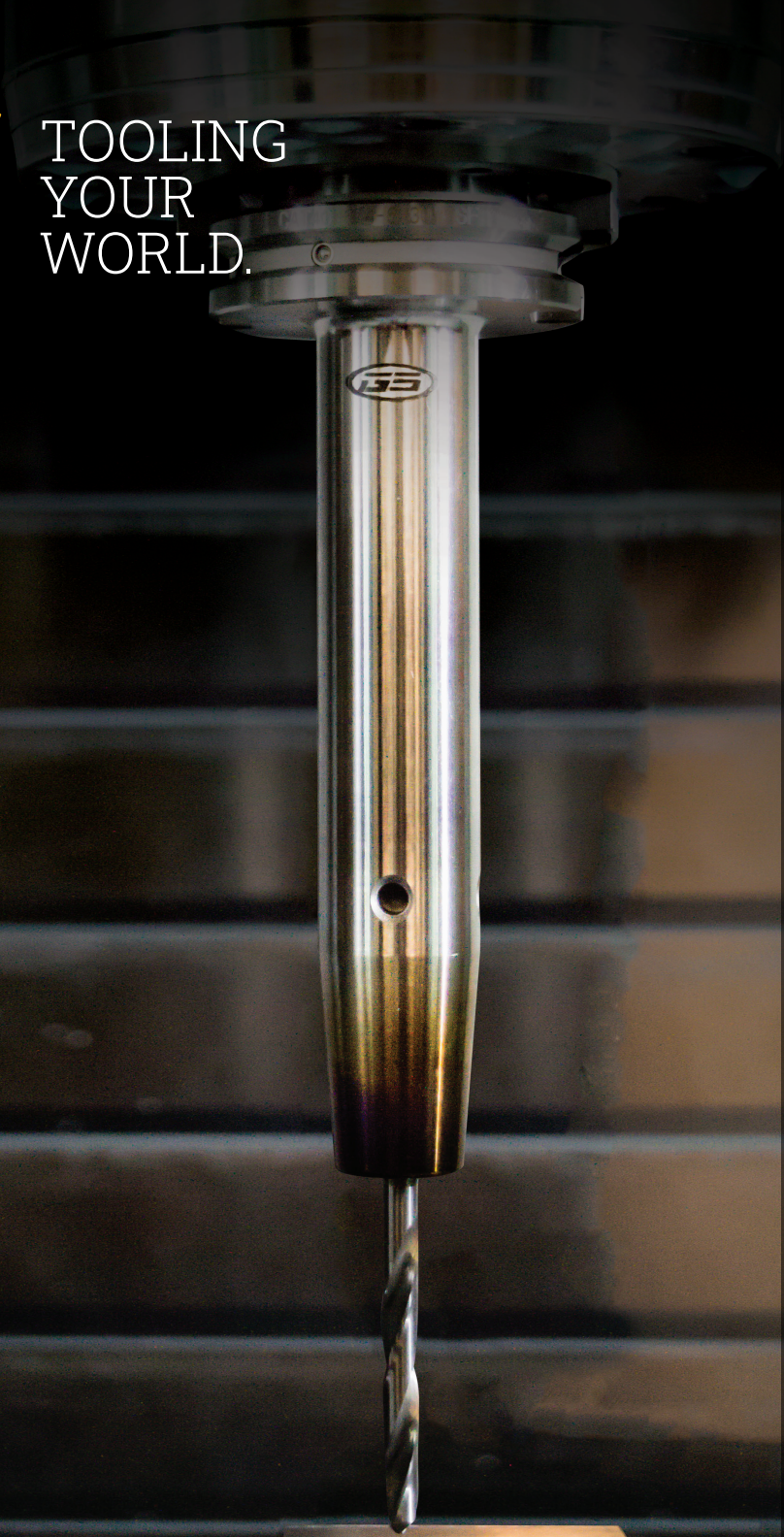

## Shrink Fit Solutions



**ShrinkSMART**

ShrinkSMART Features . . . . .	2-3
ShrinkSMART Machine, Upgrade Options & Parts . . . . .	4-5
Shrink Fit Holder Features . . . . .	6-7
CAT40/CAT50 Shrink Fit Holders . . . . .	8
BT30/BT40 Shrink Fit Holders. . . . .	9
HSK63A/HSK100A Shrink Fit Holders . . . . .	9
Bundle & SAVE! . . . . .	10



# ShrinkSMART

Modular shrink fit technology designed to be feature-rich, fast and flexible with an unrivaled entry price point.

Sowa Tool's premium brand, GS Tooling, delivers top-tier quality and performance that rivals or exceeds the best in the world.

GS Tooling products offer exceptional features and dependability, at shockingly affordable prices, making them an ideal choice for applications where accuracy and speed matter most.

## SMART Control Panel & Software

The easy to use SMART Control Panel has three optimized pre-preprogrammed cycles that save energy and prevent over-heating which can damage your holder. The software allows you to connect to a web interface through WiFi or an Ethernet connection for special programming needs and gives you a system status overview on demand.



Cooling options to suit all needs – for now and the future.

Start your shrink fit journey with a powerful solution that gives you the flexibility to add solutions as your business needs evolve.

### INCLUDED

- 1 Tube for Adapter Rings & Protecting Coil

### UPGRADE OPTION

- 2 Air-Powered Cooling Unit  
Holders that can be cooled: 1  
Average cooling time: from 50 seconds\*

# ShrinkSMART

## SMART Coil

Because toolholders can become hardened / tempered from excessive heating from some shrink machines, the SMART Coil measures the unique resistance for *each* toolholder and ensures *only* the proper and appropriate amount of heat is utilized. This also supports a super fast 2-7 second shrinking cycle.

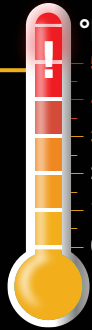
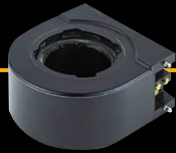

°F  
500° Machines without SMART Coil  
400°  
300° ShrinkSMART  
200° Temperatures  
100°  
0°

## Compatible with all popular tooling combinations

**Tool types:** HSS, Carbide, MST, Magnetic and Non-Magnetic

**Diameters from:** 0.118" to 1.259" (3mm to 32mm)  
1.574" (40mm) possible with the same coil using optional stop disk.

**Tapers:** CAT/BT/SK40 & 50, HSK63A & 100A, C6 & C10 (with additional adapters available for CAT/BT/SK30, SK25 & 35 & 45, HSK32 & 50 & 80, C3 & C5 & C8 CAPTO)



ALTERNATE BASE UNIT

## Rotary Table with Shrink Depth Settings

The Rotary Table stops the user from having any contact with hot holders, and allows them to safely switch from the heating position to a cooling position. The stop rods allow the user to set the depth of the cutting tool with a wheel that moves the stop rod and your tool into position. Stop rod also assists in removing broken tool.



UPGRADE OPTION

### 3 Air-Cooling Box & Storage

Holders that can be cooled: **5**  
Extra storage for holder with air-cooling function.

UPGRADE OPTION

### 4 Water-Cooling Refrigeration Unit

Holders that can be cooled: **2**  
Average cooling time: **from 45 seconds\***

\*depending on the tool holder shape

# ShrinkSMART SHRINK FIT MACHINE

**Operating Manual**

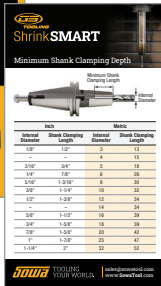

**Quick Reference Card**

<b>Power</b>	Up to 16kW allows the shrinking and unshrinking of tools Ø0.118" to Ø1.259" (Ø3mm to Ø32mm)
<b>Voltage</b>	AC 3 x 400V-480V (±10%) + PE/23.8 A/50-60Hz 2.5 meter cable is supplied Air 3-6 bars/duct Ø0.4" (Ø3mm) required
<b>Max Tool Length</b>	16" to 19.25" (406.4mm to 488.95mm)
<b>Largest Possible Taper</b>	HSK125A
<b>Weight</b>	102lbs (46.2kg) Approximate
<b>Dimensions</b>	12.5"W x 38"D x 36"H (317mm x 955mm x 920mm) Approximate

**Heat Focusing Stop Disks (5)**

Magnetic insulator allows the magnetic field to be concentrated on the front part of the tool holder to achieve optimized heating. Enables the shrinking and unshrinking of carbide or HSS tools.

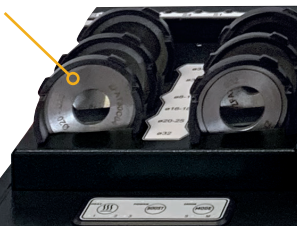

**Pi Interface (Internal)**



**GS Tooling ShrinkSMART Shrink Fit Machine**

Included	Code No.
1 SMART Coil	541650
<b>Heat Focusing Stop Disks:</b> 0.118"-0.236" (3mm-6mm), 0.314"-0.551" (8mm-14mm), 0.629"-0.708" (16mm-18mm), 0.787"-0.984" (20mm-25mm), 1.259" (32mm)	
<b>Adapter Rings:</b> 2 CAT40/BT40/SK40/HSK63A/C6 CAPTO CAT50/BT50/SK50/HSK100A/C10 CAPTO	
1 Tube for Adapter Rings	
1 Protecting Cone	
1 Pair of Gloves	
<b>Quick Reference Card:</b> 1 Clamping Depth & MODE Selection	
1 Operating Manual	
1 Pi-Interface	



SMART Coil

Gloves

(Toolholder not included)

Adapter Rings (2)

Provides the correct positioning of the tool holder into the tube.

Tube for Adapter Rings

Protecting Cone

Directs the air stream against the front end of the holder for fast cooling, and protects from contact of tooling when it is hot.

Two Fans

Built-in for improved cooling cycle times.

# ShrinkSMART

## UPGRADE OPTIONS & PARTS

### Air-Powered Cooling Unit

**Cooling time:** from 50 seconds (*Depending on the tool holder shape*)

**Weight:** 11.5lbs (5.24kg)

**Height:** 18.38" (467mm)

**Connection:** L1, N+PE

**Voltage:** 1 x 100Vac-277Vac

**Frequency:** 50/60Hz

**Air Required:** 3-6 Bars



Description	Code No.
Air-Powered Cooling Unit	541654

### Air-Cooling Box & Extra Storage for 5 Holders

**Cooling time:** from 4-5 minutes  
(*Depending on the tool holder shape*)

**Weight:** 23.15lbs (10.5kg)

**Height x Width x Depth:**  
12.48" x 19.68" x 35.8"  
(317mm x 500mm x 910mm)

**Connection:** L1, N+PE

**Voltage:** 1 x 100Vac-277Vac

**Frequency:** 50/60Hz



**INCLUDED:**  
2 fans, 5 adapter rings for CAT40/BT40/HSK63A/C6,  
5 adapter rings for CAT50/BT50/HSK100A/C10,  
2 protecting cones

Description	Code No.
Air-Cooling Box for 5 Holders	541656

### Water-Cooling Refrigeration Unit

**Cooling time:** from 45 seconds  
(*Depending on the tool holder shape*)

**Extension table:** Allow storage of  
5 contact bushings and 1 cooling bell

**Weight:** 88lbs (39.8kg)

**Height x Width x Depth  
(Table Extension):**  
14.25" x 5.69" x 35.8"  
(362mm x 150mm x 910mm)

**Height x Width x Depth  
(Refrigeration Unit):**  
18.5" x 11.42" x 22.83"  
(470mm x 290mm x 580mm)

**INCLUDED:**  
Refrigeration unit, tube support,  
2 cooling bells, extension table



Description	Code No.
Water-cooling refrigeration unit, tube support, 2 cooling bells & extension table	541688

### Rotary Table with Shrink Depth Settings

The Rotary Table stops the user from having any contact with hot holders, and allows them to safely switch from the heating position to a cooling position. The stop rods allow the user to set the depth of the cutting tool with a wheel that moves the stop rod and your tool into position. Stop Rods also assists in removing broken tools.



Description	Code No.
Rotary Table Attachment with Stop Rods	541652

### SMART Coil

Measures the holder thickness and optimizes power consumption by automatically adjusting kW and heating time for each holder. This increases the life of your tool holders.

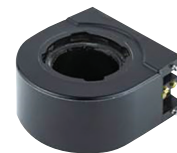

Description	Code No.
SMART Coil	541686

### Parts



Heat Focusing Stop Disk



Split Heat Focusing Stop Disk



Adapter Rings



Protecting Cone



Pair of Gloves



Stop Rods  
(Set of 4 pc)



Finned Support Cooling Adapter



Cooling/Contact Bushing



Tube for Adapter Rings



Tube for Adapter Rings with Stop Rod Depth Setter

Description	Code No.	
Protecting Cone	541658	
Tube for Adapter Rings	541660	
Tube for Adapter Rings with Stop Rod Depth Setter	541661	
Stop Rods	4 pc 4.2mm diameter	541714
	4 pc 2.5mm diameter	541715
Pair of Heat Resistant Gloves ( <i>May not look exactly as shown</i> )	541712	
Adapter Rings	CAT40/BT40/SK40/HSK63A/C6 CAPTO	541662
	CAT50/BT50/SK50/HSK100A/C10 CAPTO	541664
	BT30/SK30/HSK40A/C4 CAPTO	541666
	SK25/HSK32A/C3 CAPTO	541668
	SK35/HSK50A/C5 CAPTO	541670
Heat Focusing Stop Disks	SK45/HSK80A/C8 CAPTO	541672
	0.118"-0.236" (3mm-6mm)	541674
	0.314"-0.551" (8mm-14mm)	541676
	0.629"-0.708" (16mm-18mm)	541678
	0.787"-0.984" (20mm-25mm)	541680
Split Heat Focusing Stop Disks	1.259" (32mm)	541682
	0.118"-0.236" (3mm-6mm)	541675
	0.314"-0.551" (8mm-14mm)	541677
	0.629"-0.708" (16mm-18mm)	541679
	0.787"-0.984" (20mm-25mm)	541681
Finned Support Cooling Adapters ( <i>Additional sizes can be quoted on request</i> )	1.259" (32mm)	541683
	CAT40/BT40	541690
	CAT50/BT50	541692
	BT30	541694
	HSK63A	541696
Cooling/Contact Bushings DIN4.5°	C6 CAPTO	541698
	1/8" & 3/16" (3/4/5mm)	541700
	1/4" & 5/16" (6/8mm)	541702
	3/8" & 7/16" & 1/2" (10/12mm)	541704
	9/16" & 5/8" (14/16mm)	541706
Stop Rods	3/4" (18/20mm)	541708
	1" & 1-1/4" (25/32mm)	541710



# Shrink Fit Tool Holders

## Only the best material is used

GS Tooling Shrink Fit Holders are made from **H13 Tool Steel**. This is a chromium-molybdenum steel with an exceptional combination of high toughness and resistance to thermal fatigue cracking (heat checking) as a result of cyclic heating and cooling cycles. It has better wear resistance than common alloy steels, and with proper use the life of our Shrink Fit Holders will exceed that of standard Shrink Fit Holders.

Our taper accuracy is **AT2 or better**, for the life of the holder – **guaranteed**.

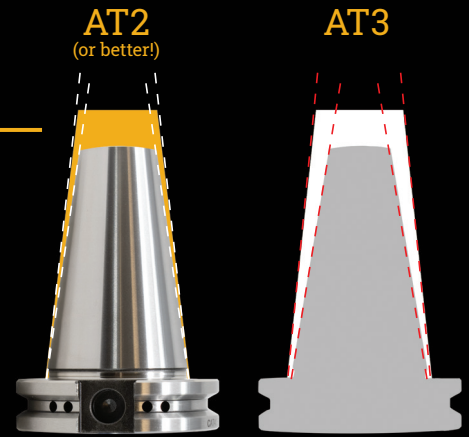

## Multiple coolant options are standard

Coolant through tool:

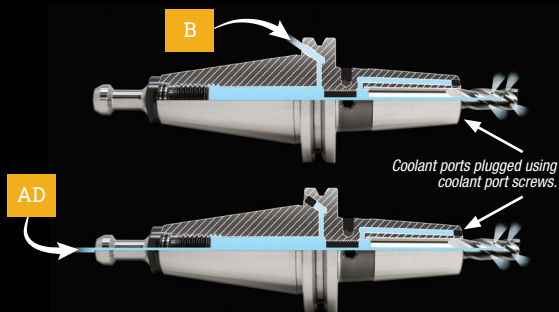

Coolant through coolant ports:

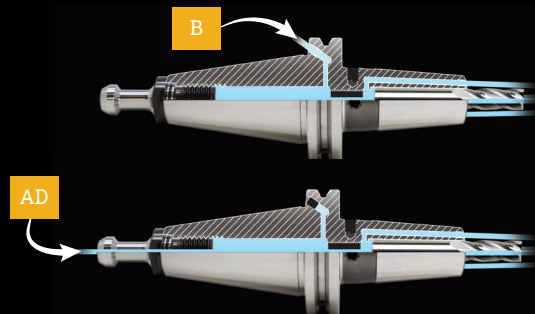

Four Coolant Ports in the Nose

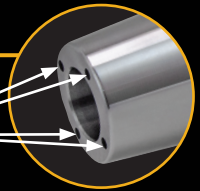

GS Tooling coolant-through Shrink Fit Holders require no special backup screws or seals. The fit between the I.D. of the holder and cutting tool shank forms the seal, preventing the coolant from flowing anywhere else except through the coolant ports. Coolant ports can be closed with a 3mm set screw.

## GS Tooling shrink fit holders and components are ground to perfection

For an extra level of precision, we start with prebalanced holders and components. We then invest the time to grind all surfaces that will be in contact with the machine to a fine finish, giving our holder a **runout accuracy of 0.0001"** and our **taper and collet cavities an accuracy of AT2 or better** (Compare this with the runout accuracy of 0.0002" and taper accuracy AT3 of other brands). This offers a tighter connectivity and grip in all mated areas, increasing tolerances throughout.

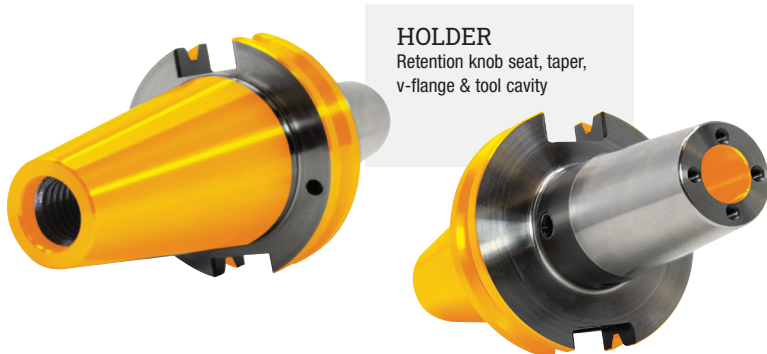

**PREMIUM BALANCE**  
**G2.5 at 30,000rpm**  
**CERTIFICATE INCLUDED**  
CAT/BT 30, 40, HSK63A

**PREMIUM BALANCE**  
**G2.5 at 25,000rpm**  
**CERTIFICATE INCLUDED**  
CAT50, HSK100A

Artist rendering uses a gold color on the holder and components to clearly show all surfaces that are ground.



  
 Coolant Port Screws  
 4 screws included with  
 holders over 6mm I/D.

## Quality QC

All GS Tooling holders are inspected, one piece at a time. An individualized balance certificate of inspection is included with each holder.

		<b>BALANCE CERTIFICATION</b>	
Machine: _____	_____		
Rotor Name: _____	Date: _____	Correction Diameter: _____	_____
Rotor No.: _____	Correction Mode: _____	_____	
Measuring Speed: _____	Result: _____		
This Holder is Balanced To		/ RPM	
Signature: _____			
For Customer Service Inquiries please call Sowa Tool & Machine Co. Ltd. at 1-800-265-8221			

## Explore all of our rotary tooling systems.

Sowa Tool offers a large SKU offering of a wide range of quality rotary tooling: End Mill Holders, Collet Chucks & Collets, Shell Mill & Face Mill Holders, Shrink Fit Holders, Tap Holders, Driven Tooling and Angle Heads.



## CAT40/CAT50 Shrink Fit Holders With Coolant Ports

**Simple and fast.** The total time elapsed to remove one cutting tool and insert another is **less than 10 seconds**.

**Four coolant ports come standard** for through-spindle coolant capability, allowing for even faster cutting speeds!

**Balanced & Certified** – the best out there!  
**G2.5 at 30,000rpm** (CAT/BT 30, 40, HSK63A)  
**G2.5 at 25,000rpm** (CAT50, HSK100A)

Tool is **gripped 360° along the entire length of the bore**. This results in maximum clamping force, greater rigidity, and an exceptional concentricity (0.0001"/0.003mm). You can run your machine at faster speeds and feeds with no danger of the tool slipping or bending.

**Short projections are possible** because no mechanical clamping devices are used. No moving parts and low centrifugal forces due to low holder mass allow for a **long holder life with tighter tolerances**.

**Chip load is distributed evenly along the cutting edge** of the tool which results in longer tool life.

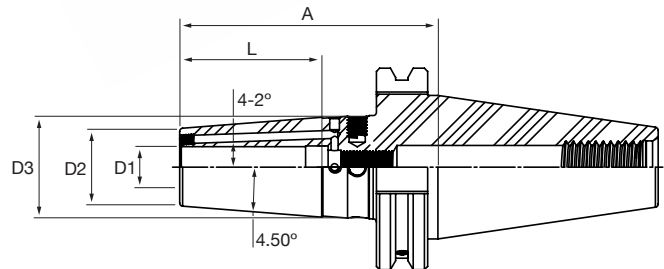

Taper	Hole Diameter (D1)	Gage Length (A)	D2	D3	L	Code No.
<b>Inch</b>						
<b>CAT40</b>	1/8"	3.15"	0.59"	0.787"	0.35"	541838*
	3/16"	3.15"	0.59"	0.787"	0.47"	541840*
	1/4"	3.15"	0.83"	1.06"	1.42"	541842
	1/4"	6.30"	0.83"	1.06"	1.42"	541844
	5/16"	3.15"	0.83"	1.06"	1.42"	541846
	5/16"	6.30"	0.83"	1.06"	1.42"	541848
	3/8"	3.15"	0.94"	1.26"	1.65"	541850
	3/8"	6.30"	0.94"	1.26"	1.65"	541852
	1/2"	3.15"	0.94"	1.26"	1.65"	541854
	1/2"	6.30"	0.94"	1.26"	1.65"	541856
	5/8"	3.15"	1.06"	1.34"	1.97"	541858
	3/4"	3.15"	1.30"	1.65"	2.05"	541862
	3/4"	6.30"	1.30"	1.65"	2.05"	541864
	1"	3.94"	1.73"	2.09"	2.28"	541866
1"	6.30"	1.73"	2.09"	2.28"	541868	
1-1/4"	3.94"	1.73"	2.09"	2.28"	541870	
1-1/4"	6.30"	1.73"	2.09"	2.28"	541872	
<b>CAT50</b>	1/4"	3.15"	0.83"	1.06"	1.42"	541932
	1/4"	6.30"	0.83"	1.06"	1.42"	541934
	5/16"	3.15"	0.83"	1.06"	1.42"	541936
	3/8"	3.15"	0.94"	1.26"	1.65"	541940
	3/8"	6.30"	0.94"	1.26"	1.65"	541942
	1/2"	3.15"	1.06"	1.34"	1.65"	541944
	1/2"	6.30"	0.94"	1.26"	1.65"	541946
	5/8"	3.15"	1.06"	1.34"	1.97"	541948
	5/8"	6.30"	1.06"	1.34"	1.97"	541950
	3/4"	3.15"	1.30"	1.65"	2.05"	541952
	3/4"	6.30"	1.30"	1.65"	2.05"	541954
	1"	3.94"	1.73"	2.09"	2.28"	541956
	1"	6.30"	1.73"	2.09"	2.28"	541958
	1-1/4"	3.94"	1.73"	2.09"	2.28"	541960
1-1/4"	6.30"	1.73"	2.09"	2.28"	541962	

Taper	Hole Diameter (D1)	Gage Length (A)	D2	D3	L	Code No.
<b>Metric</b>						
<b>CAT40</b>	4mm	80mm	15mm	20mm	12mm	541802*
	6mm	80mm	21mm	27mm	36mm	541806
	6mm	160mm	21mm	27mm	36mm	541808
	8mm	80mm	21mm	27mm	36mm	541810
	8mm	160mm	21mm	27mm	36mm	541812
	10mm	80mm	24mm	32mm	42mm	541814
	10mm	160mm	24mm	32mm	42mm	541816
	12mm	80mm	24mm	32mm	47mm	541818
	12mm	160mm	24mm	32mm	47mm	541820
	16mm	80mm	27mm	34mm	50mm	541822
	16mm	160mm	27mm	34mm	50mm	541824
	20mm	80mm	33mm	42mm	52mm	541826
	25mm	100mm	44mm	53mm	58mm	541830
	32mm	100mm	44mm	53mm	58mm	541834
<b>CAT50</b>	6mm	80mm	21mm	27mm	36mm	541900
	6mm	160mm	21mm	27mm	36mm	541902
	8mm	80mm	21mm	27mm	36mm	541904
	8mm	160mm	21mm	27mm	36mm	541906
	10mm	80mm	24mm	32mm	42mm	541908
	10mm	160mm	24mm	32mm	42mm	541910
	12mm	80mm	24mm	32mm	47mm	541912
	12mm	160mm	24mm	32mm	47mm	541914
	16mm	80mm	27mm	34mm	50mm	541916
	16mm	160mm	27mm	34mm	50mm	541918
	20mm	80mm	33mm	42mm	52mm	541920
	25mm	100mm	44mm	53mm	58mm	541924
	32mm	100mm	44mm	53mm	58mm	541928

\*No coolant ports or threaded balance holes on holders under 6mm I.D.



## BT30/BT40 Shrink Fit Holders With Coolant Ports

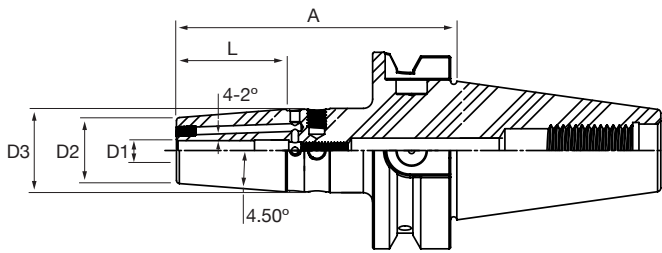

Taper	Hole Diameter (D1)	Gage Length (A)	D2	D3	L	Code No.
<b>Inch</b>						
<b>BT30</b>	1/8"	3.15"	0.39"	-	0.35"	542414*
	3/16"	3.15"	0.39"	-	0.47"	542416*
	1/4"	3.15"	0.83"	1.06"	1.42"	542418
	3/8"	3.15"	0.94"	1.26"	1.65"	542422
	1/2"	3.15"	0.94"	1.26"	1.65"	542424
<b>BT40</b>	3/16"	3.54"	0.39"	-	0.47"	542466*
	1/4"	3.54"	0.83"	1.06"	1.42"	542468
	1/4"	6.30"	0.83"	1.06"	1.42"	542470
	3/8"	3.54"	0.94"	1.26"	1.65"	542476
	1/2"	3.54"	1.06"	1.34"	1.65"	542480
	1/2"	6.30"	1.06"	1.34"	1.65"	542482
	3/4"	3.54"	1.30"	1.65"	2.05"	542488
	3/4"	6.30"	1.30"	1.65"	2.05"	542490
	1"	3.94"	1.73"	2.09"	2.28"	542492
	1-1/4"	3.94"	1.73"	2.09"	2.28"	542496
<b>Metric</b>						
<b>BT30</b>	4mm	80mm	10mm	-	12mm	542402*
<b>BT40</b>	6mm	90mm	21mm	27mm	36mm	542432
	8mm	90mm	21mm	27mm	36mm	542436

## Coolant Port Screws

Set screws that allow you to close coolant ports.  
4 screws per package.  
No coolant ports on holders under 6mm I.D.



Description	Overall Length	Code No.
Coolant port screws	3mm	541801

## HSK63A/HSK100A Shrink Fit Holders With Coolant Ports

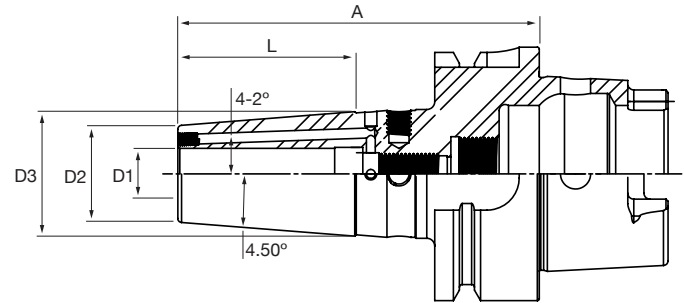

Taper	Hole Diameter (D1)	Gage Length (A)	D2	D3	L	Code No.
<b>Inch</b>						
<b>HSK63A</b>	1/8"	3.15"	0.59"	0.787"	0.35"	546338*
	3/16"	3.15"	0.59"	0.787"	0.47"	546340*
	1/4"	3.15"	0.826"	1.06"	1.42"	546342
	1/4"	6.30"	0.83"	1.06"	1.42"	546344
	5/16"	3.15"	0.826"	1.06"	1.42"	546346
	3/8"	3.35"	0.94"	1.26"	1.65"	546350
	3/8"	6.30"	0.94"	1.26"	1.65"	546352
	1/2"	3.54"	1.06"	1.34"	1.65"	546354
	1/2"	6.30"	1.06"	1.34"	1.65"	546356
	5/8"	3.74"	1.06"	1.34"	1.97"	546358
	5/8"	6.30"	1.06"	1.34"	1.97"	546360
	3/4"	3.94"	1.30"	1.65"	2.05"	546362
	3/4"	6.30"	1.30"	1.65"	2.05"	546364
	1"	4.53"	1.73"	2.09"	2.28"	546366
	1"	6.30"	1.73"	2.09"	2.28"	546368
1-1/4"	4.72"	1.73"	2.09"	2.28"	546370	
1-1/4"	6.30"	1.73"	2.09"	2.28"	546372	
<b>HSK100A</b>	1/4"	3.35"	0.826"	1.06"	1.42"	546432
	5/16"	3.35"	0.826"	1.06"	1.42"	546436
	3/8"	3.54"	0.94"	1.26"	1.65"	546440
	3/8"	6.30"	0.94"	1.26"	1.65"	546442
	1/2"	3.74"	1.06"	1.34"	1.65"	546444
	1/2"	6.30"	1.06"	1.34"	1.65"	546446
	5/8"	3.94"	1.06"	1.34"	1.97"	546448
	5/8"	6.30"	1.06"	1.34"	1.97"	546450
	3/4"	4.13"	1.30"	1.65"	2.05"	546452
	3/4"	6.30"	1.30"	1.65"	2.05"	546454
	1"	4.53"	1.73"	2.09"	2.28"	546456
	1"	6.30"	1.73"	2.09"	2.28"	546458
	1-1/4"	4.72"	1.73"	2.09"	2.28"	546460
	1-1/4"	6.30"	1.73"	2.09"	2.28"	546462
	<b>Metric</b>					
<b>HSK63A</b>	3mm	80mm	15mm	20mm	-	546300*
	4mm	80mm	15mm	20mm	12mm	546302*
	5mm	80mm	15mm	20mm	15mm	546304*
	6mm	80mm	21mm	27mm	36mm	546306
	6mm	160mm	21mm	27mm	36mm	546308
	8mm	80mm	21mm	27mm	36mm	546310
	10mm	85mm	24mm	32mm	42mm	546314
	12mm	90mm	24mm	32mm	47mm	546318
	16mm	95mm	27mm	34mm	50mm	546322
	20mm	100mm	33mm	42mm	52mm	546326
	25mm	115mm	44mm	53mm	58mm	546330
	32mm	120mm	44mm	53mm	58mm	546334

\*No coolant ports or threaded balance holes on holders under 6mm I.D.

Don't just shrink fit,  
**ShrinkSMART**  
with a GS Tooling  
ShrinkSMART bundle.

AI makes all the difference



### Solid Carbide End Mills

Solid sub-micron micrograin carbide end mills, ground to a tolerance of h6 in a variety of finishes, flutes and types. Ideal for shrink fit technologies providing unrivaled value for your money!

### ShrinkSMART Machine

Easy enough for anyone to use, ShrinkSMART does all the work. This ensures the holder does not overheat, giving you optimized tool performance.

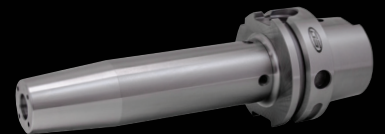

### Shrink Fit Holders

Made from H13 Tool Steel, ground to perfection and certified G2.5 at 30,000rpm (CAT/BT 30, 40, HSK63A), G2.5 at 25,000rpm (CAT50, HSK100A)... with four coolant ports standard!

Special bundle and bulk pricing available, contact us for a quote.



**ShrinkSMART**



## Superior performance tooling solutions when speed and accuracy matter most.

GS Tooling is an industry leader in precision tooling where high-performance and stringent quality standards are essential. Tool Your World with GS Tooling End Mill Holders, Collet Chucks & Collets, Shrink Fit Solutions, Retention Knobs, Vises & Workholding, Live Centers, Angle Heads, Carbide End Mills and more!



Shop  
GS Tooling



Tool Holding



Angle Heads & Driven Tooling



Cutting Tools

Shrink Fit Solutions

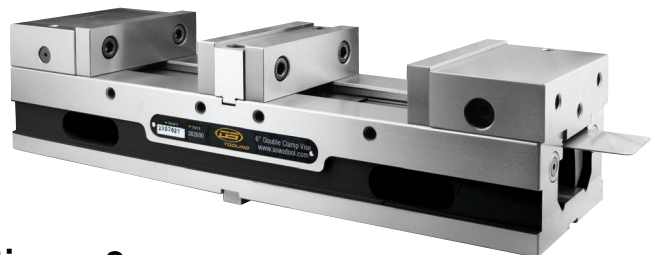

Vises & Workholding



# SOWA's complete line of metalworking solutions



Sowa Tool's premium brand delivers top-tier quality and performance that rivals or exceeds the best in the world. These products offer premium features and dependability, at shockingly affordable prices, making them an ideal choice for applications where accuracy and speed matter most.

## ASIMETO

Sowa's family of metrology solutions deliver absolute confidence born from its European engineering, and each tool beginning its journey in our ISO 17025 accredited labs. This premium heritage product priced at a non-premium price, delivers significant value for your money.



With our Sowa branded tools, we bring to our customers high performance cutting tools engineered to deliver superior tool life, machining efficiency & quality while still offering maximum value for your money.

## SKODA

Sowa Tool's exclusive line of general-purpose live centres with its roots in European quality that deliver excellent accuracy, rigidity, and durability at a price point that suits most budgets. Sowa carries a wide range of in-stock standard models to suit most common turning applications.



Sowa Tool's exclusive line of European universal boring and facing heads offer superior accuracy and precision for all your facing and boring applications. They feature an easy-to-adjust design, durable castings, and precision spindle bearings for a consistently accurate finish.



Our approach to this brand ensures that our customers receive the best value for their investment by delivering a broad assortment of metalworking tools at an exceptional price. These tools typically apply to less demanding applications seen on the standard shop floor where the cost of the tool has the greatest influence on the selection process.



### At Sowa Tool & Machine

we understand the needs of machining processes, and our extensive product lines offer a comprehensive solution. Our goal is to provide customers with the cost benefits of a single-source supplier, while remaining committed to delivering the highest quality products.

Ask for them by name!



### Sowa Tool & Machine Co. Ltd.

Canadian Headquarters  
500 Manitou Drive, Kitchener, ON, N2C 1L3  
US Headquarters  
101-137 Overhill Drive, Mooresville, NC 28117

### Shop Online:

www.[SowaTool.ca](http://SowaTool.ca)  
sales@sowatool.com  
TF: 1-800-265-8221